

Service Manual – Combo Brewer

Models Included

- CBS
- CBP

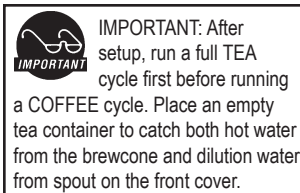
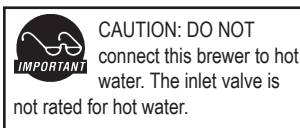
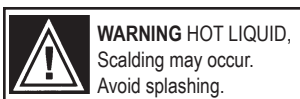

Important Safeguards/Conventions

This appliance is designed for commercial use. Any servicing other than cleaning and maintenance should be performed by an authorized Wilbur Curtis service center.

- Do NOT immerse the unit in water or any other liquid
- To reduce the risk of fire or electric shock, do NOT open top or front panel. No user serviceable parts inside. Repair should be done only by authorized service personnel.
- Keep hands and other items away from hot parts of unit during operation.
- Never clean with scouring powders, bleach or harsh implements.

Conventions



WARNINGS – To help avoid personal injury



Important Notes/Cautions – from the factory



Sanitation Requirements

Your Curtis G3 Brewer is Factory Pre-Set and Ready to Go... Right out of the Carton.

Following are the Factory Settings for your Coffee/Tea Brewing System:

- Brew Temperature = 204°F
- Brew Volume = Set to dispensing vessel requirements

Generally there will never be a reason to change your G3 programming. However, should you need to make slight adjustments to meet your brewing needs, programming instructions are provided later in this manual.

System Requirements:

- Water Source 20 – 90 PSI (Minimum Flow Rate of 1 GPM)
- Electrical: See attached schematic for standard model or visit www.wilburcurtis.com for your model.

Equipment to be installed to comply with applicable federal, state, or local plumbing/electrical codes having jurisdiction.

SETUP STEPS

The unit should be level (left to right and front to back), located on a solid counter top. Connect a water line from the water filter to the brewer. **NOTE:** Some type of water filtration device must be used to maintain a trouble-free operation. (In areas with extremely hard water, we suggest that a sedimentary and taste & odor filter be installed.) This will prolong the life of your brewing system and enhance coffee and tea quality.



The National Sanitation Foundation requires the following water connection:

1. A quick disconnect or additional coiled tubing (at least 2x the depth of the unit) so that the machine can be moved for cleaning underneath.
2. In some areas an approved backflow prevention device may be required between the brewer and water supply.

1. A 1/4" Flare has been supplied for water line connection. Use tubing sized sufficiently to provide a minimum of 1.0 GPM.
2. Connect the unit to an appropriate electrical power circuit.
3. Turn on the toggle (STANDBY/ON) switch behind the unit. The heating tank will start to fill. When the water level in the tank rises to the correct volume, the heating element will energize automatically. With G3 Systems there is no danger of element burnout due to an unfilled heating tank.
4. The heating tank will require 20 to 30 minutes to reach operating temperature (204°F) as indicated by the READY-TO-BREW LED readout.
5. Important: Run one full TEA brewcycle first, before running a coffee brewcycle to purge water lines and valves of air. Five seconds of pulsing dilution water at the beginning of each TEA brewcycle is normal pre-programmed operating behavior.

BREWING INSTRUCTIONS – COFFEE

1. The brewer should be ON (Confirm at rear toggle switch, then press ON/OFF button on control panel). Ready-to-Brew should be displayed on the UCM screen.
2. Make sure folding airpot deck is rotated upright. Place a clean, empty airpot on the airpot brew deck.
3. Place a new paper filter into the brewcone.

4. Pour ground coffee into brewcone marked COFFEE



5. Position filled brewcone into brew rails.



6. Press COFFEE Brew button.

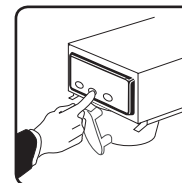

BREWING INSTRUCTIONS – TEA

1. Brewer should be ON (Confirm at rear toggle switch, then press ON/OFF button) and Ready-to-Brew displayed.
2. Make sure deck is folded down and tea container is in place.



IMPORTANT – Tea container must be pushed all the way to the back to ensure the safety switch is engaged and tea brewing can start.

3. Place filter in brew basket. Pour leaf tea into basket marked ICED TEA or TROPICAL TEA.
4. Slide brew cone into brew rails. Place tea container under brew cone.
5. Slide container in to activate switch behind folded coffee deck.
6. Press the TEA BREW button.

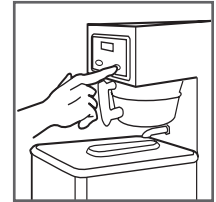
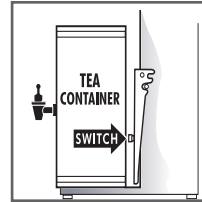
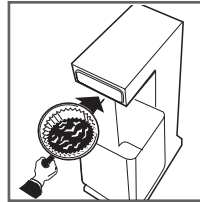
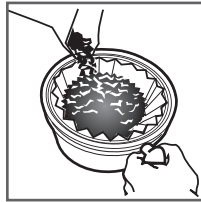

WARNING DO NOT refrigerate unused tea overnight for later consumption.

TEA TIPS

1. Store tea bags in a dark, cool and dry place away from strong odors and moisture. Do not refrigerate.
2. Never hold finished brewed tea for more than eight hours at room temperature. Discard any unused tea after eight hours.
3. Brew only enough tea that you reasonably expect to sell within a few hours.
4. To protect tea flavor and to avoid bacterial contamination and growth, clean and sanitize tea brewing, storage and dispensing equipment at least once a day.

CLEANING

Regular cleaning of your airpots and tea containers will maintain the highest quality coffee and iced tea your equipment is capable of producing. A proper cleaning is essential in preserving the appearance of the brewer.

1. Turn off the unit button on the front control panel.
2. Wipe exterior surfaces with a damp cloth, removing spills and debris.
3. Slide the brewcone out and clean it. Thoroughly soap the sprayhead area with a mild detergent solution.
4. Wash the brewcone and wire brew basket, if applicable. Use a soft bristled brush for hard to clean areas. Wash both parts with a detergent solution or put these parts through a dishwasher.
5. Wash the tea container and top cover with a detergent solution. Remove the faucet assembly. Unscrew the handle assembly from the faucet and remove. Clean the faucet shank with a gage glass brush (circular bristle) by pushing the brush through the shank. Using the same brush clean the faucet body inlet and outlet. Clean the faucet cap and silicone seat cup.
6. After the cleaning, place the parts (sprayhead, brewcone and basket and faucet parts) into a sink to be sanitized. To sanitize the disassembled parts:
 - A. Use a clean container to submerge all parts. Wear rubber gloves for protection.
 - B. Immerse in commercial Bar Tabs/Sani-Tabs sanitizing solution. The solution must be warm (75°F.) Let the parts soak for at least one minute.
7. Thoroughly rinse parts with hot water. Air dry, all parts that were sanitized.
8. After cleaning, sanitizing and drying, assemble any parts taken from the tea container.
9. Clean out airpots with a sponge brush and a mild detergent solution. To remove mineral deposits, fill liner with vinegar and allow to soak.



IMPORTANT: Clean out the screen, within the brewcone, to maintain the flow of brewed tea. Neglecting this screen will eventually cause the brewcone to overflow, spilling hot liquid over the unit.



CAUTION: DO NOT use undiluted bleach or chlorine.



CAUTION Do not immerse airpots in water.



- Do not place in dishwasher.
- Do not use harsh powders or cleansers containing chlorine.
- Do not use a wire brush or pot scourer to clean inside liner.

Tank Temperature Check

Turn on brewer at the control panel ON/OFF button. Press and hold  button (see illustration, page 3) for 5 seconds. Water Temperature will be displayed (temperature in heating tank).

Your Curtis ADS System is Factory Pre-Set for Optimum Performance.

After connection to water and power; the rear toggle switch must be on. You will hear a beep sound, indicating power is available to the controller.



The control displays  Press ON/OFF button and the screen will display  After three seconds,  displayed.

Water will fill the tank (approximately 2-3 minutes depending on water flow rate). When the proper level is reached  will appear on the screen. It takes approximately 20 minutes to reach setpoint temperature of 204°F.

Control will display  when temperature reaches the setpoint (204°F). Unit is now ready to brew.

To Go Into Programming

Turn off (dark display) by pressing ON/OFF button (yellow). Press and hold BREW button (4)(green) and then press and release ON/OFF button (yellow).

Continue holding BREW button. Display will read , wait until  is displayed Enter the 4-digit access code, the digits 1-4 correspond to the buttons (see illustration below).

The default code set at the factory is 1-2-3-4. Then  will be displayed.

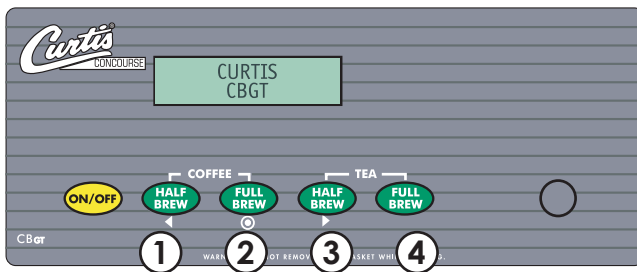

All programming selections are performed with the three center buttons. The symbols below the buttons are:

- ◀ Scroll LEFT ①
- ⊙ SELECTION or ENTER to save new parameter ②
- ▶ Scroll RIGHT ③

PROGRAM MENUS

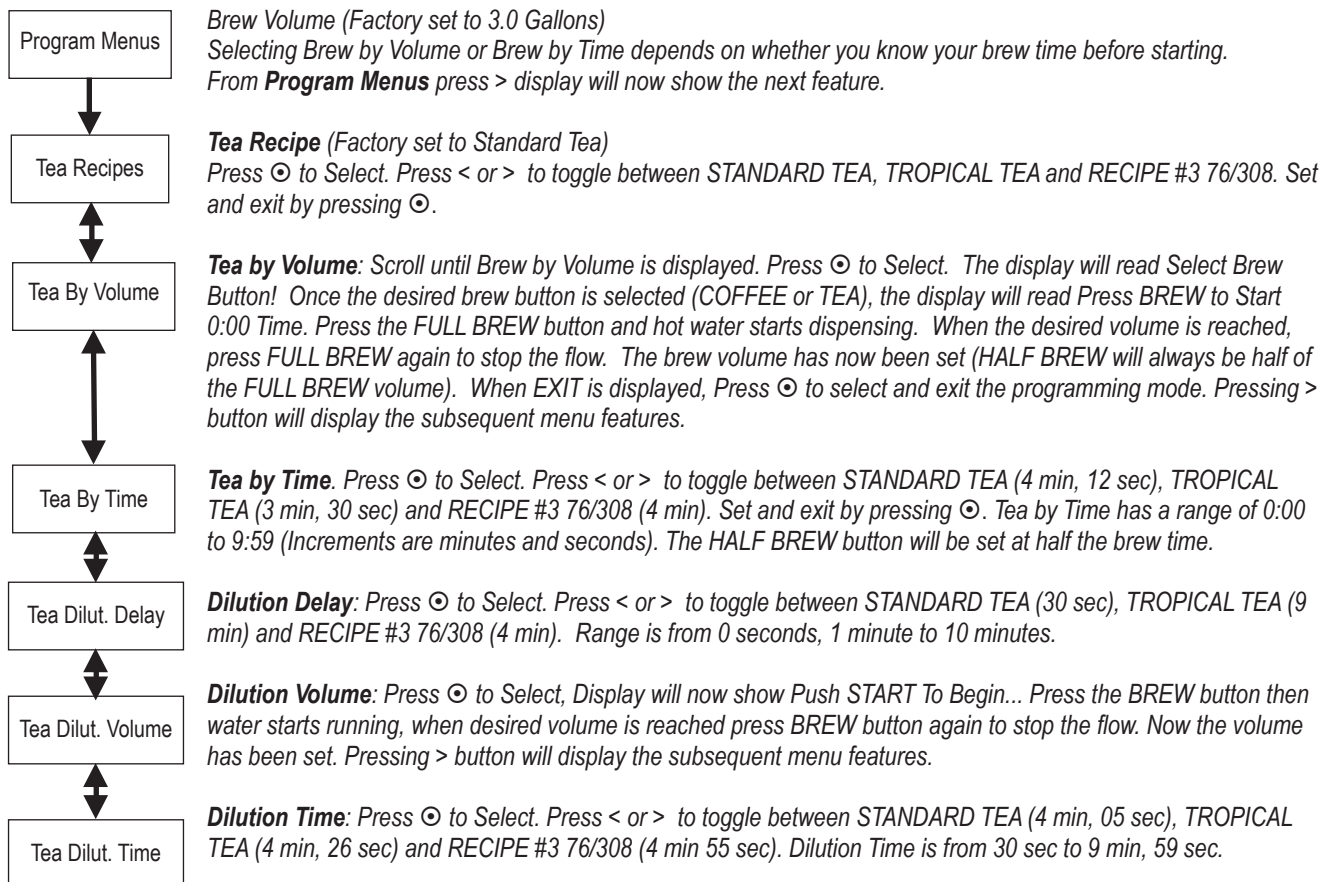

Continued on Page 4

PROGRAM MENUS CONTINUED

Tea Dilution Stir

Tea Dilution Stir (Factory set to Standard Tea).

Press **⊙** to Select, press < or > for a choice of Standard Tea, Tropical Tea or Recipie #3. Dilution Stir applies only to the Dilution cycle, by pulsing the dilution time 45 seconds on, 5 seconds off.

Tea Pluse Brew

Tea Pluse Brew (Factory set to OFF).

Press **⊙** to Select, press < or > to choose ON/OFF or D (manual programming). D will give you a pulsing spray of 1-20 pulses on and off at 5 second increments, depending on the total time set for brew (see Tea by Time).

Tea Fast Brew

Tea Fast Brew (Factory set to OFF).

Press **⊙** to Select, press < or > to choose ON or OFF. Selecting ON will start hot water spraying in the brewcone first and then 1 minute later the dilution water will start to flow.

Coffee By Volume

Coffee by Volume: Press **⊙** to Select, Display will now show Push START To Begin... Press the FULL BREW button then hot water starts running, when desired volume is reached press FULL BREW button again to stop the flow. Now the volume has been set (HALF BREW will always be half of the FULL BREW volume).

Coffee By Time

Next item in the sequence is **Brew by Time**. Press **⊙** to Select to change the brew time. Display will now show the current time. By pressing < or > you can toggle back and forth from minutes to seconds to exit (ex). Change the time or set and exit by pressing **⊙**.

Coffee Preinfusion

Pre-Infusion (Factory set to OFF)

Press **⊙** to Select. Current setting in seconds is displayed < to decrease or select > to increase (range from OFF to 10 through 60 seconds), **⊙** to set.

If Pre-infusion is selected (ON), Cold Brew Lock is set to Delta 1 within 5°F of set point and Cold Brew Lock disappears from the list of program selections. When Pre-infusion is ON, Pulse Brew disappears from the list of program selections.

Coffee Pulse Brew

Pulse Brew (Factory setting OFF)

Press **⊙** to select, < or > to select OFF or one of four pulse patterns (A to D).

Guidelines for Pulse Brew:

This feature allows tuning of the coffee flavor. This option should only be used with the standard Gray or Purple AFS sprayheads. The pot level should always be set first with this option OFF. Depending on your grind profile and water conditions, the three Pulse Brew options help "tune" or change the coffee flavor. Filter Pack type coffees typically extract better with the A and B pulse setting. Decaff coffees typically extract better with the B pulse setting. High-Yield coffees typically extract better with the C pulse setting. Of course, any of the A, B or C settings may be used to suit your taste profile.

If Pulse Brew is selected (ON), Cold Brew Lock is set to Delta 1 within 5°F of set point and Cold Brew Lock disappears from the list of program selections.

When Pulse Brew is ON, Pre-infusion disappears from the list of program selections.

Coffee Drip-out Mode

Drip-out Mode (Factory set to 2 minutes)

Press **⊙** to Select. Press < or > to move to desired time. Settings are OFF, 1, 2, 3, 4 and 5 minutes. Press **⊙** to Select time.

Temperature

Temperature (Factory set to 204°F)

Press **⊙** to Select. Press < or > to move to desired temperature and then **⊙** to set. Temperature is programmable from 170°F to 204°F in 2-degree increments.

Energy Save Mode

Energy Save Mode (Factory set to OFF)

Press **⊙** to Select, < or > ON, OFF or ON 140°F, **⊙** to set. When in ON, unit will automatically shut off 4 hours from last brew. When feature is OFF, unit does not have the energy saving mode.

In the ON 140°F position, temperature goes down to 140°F, if unit has not brewed in 4 hours. This feature will save energy by maintaining a lower temperature in the tank in periods of non-operation.

Continued on Page 5

PROGRAM MENUS CONTINUED

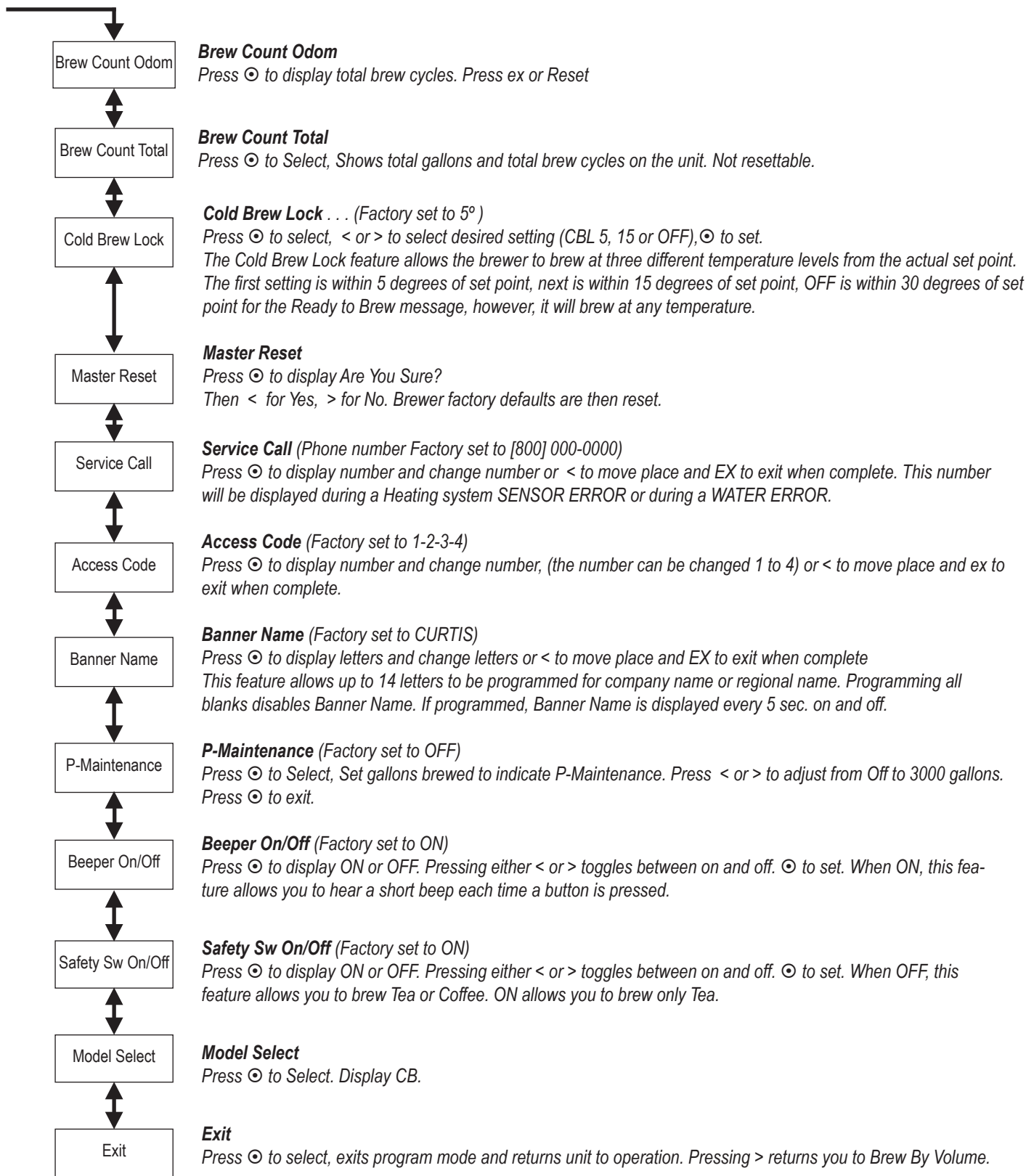

ILLUSTRATED PARTS LIST

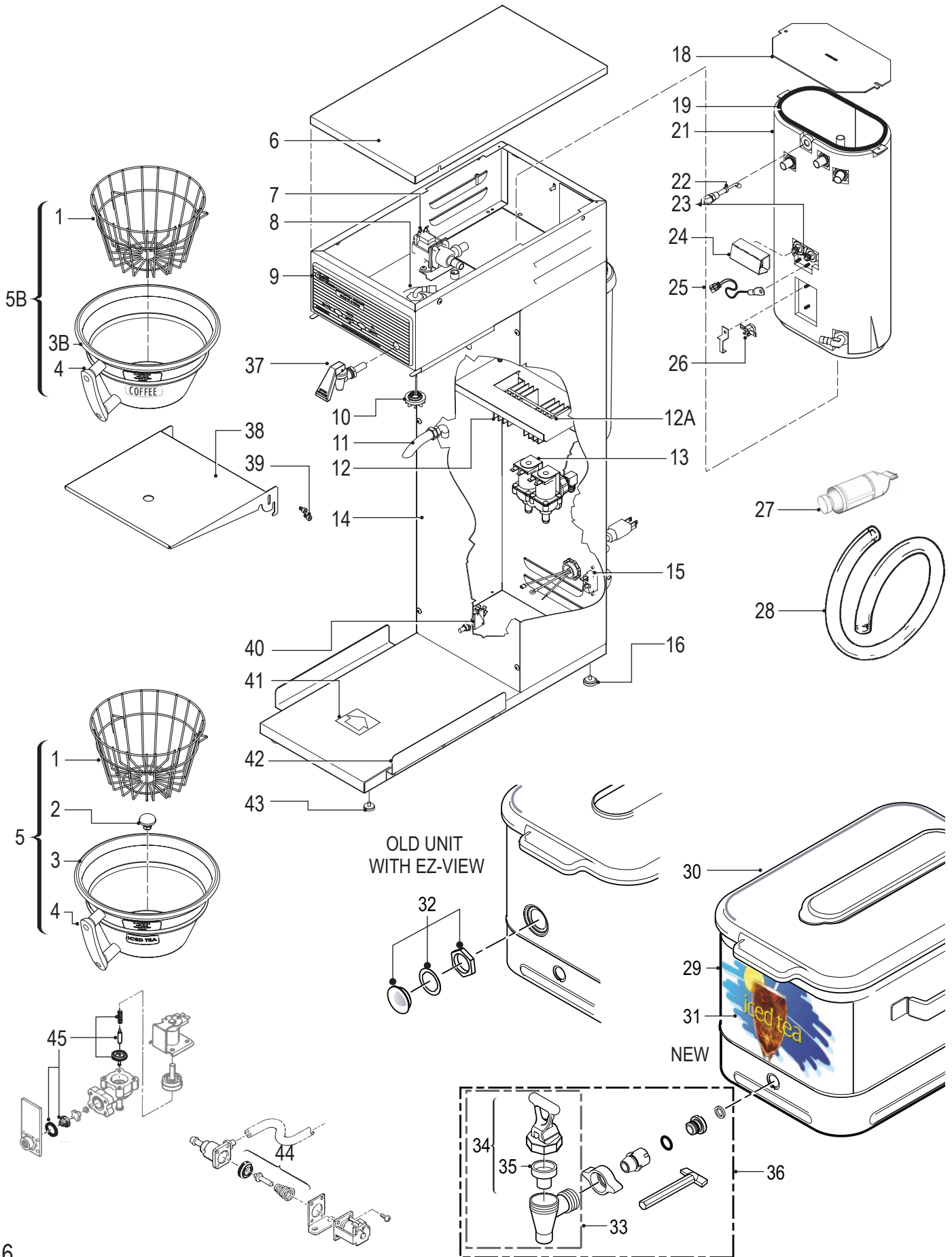

PARTS LIST

Illustrated Parts List
Curtis Combo Coffee & Tea Brewer

ITEM	PART N ^o	DESCRIPTION	ITEM	PART N ^o	DESCRIPTION
1	WC-3301	BASKET, WIRE	22	WC-5502-01*	PROBE ASSY, W/HEX FITTING, O'RING & NUT
2	WC-3647	STRAINER BT-10 BREWCONE (EXCEPT PARADISE)	23	WC-904-04*	ELEMENT, HEATING 1.6KW 120V W/JAM NUTS
3	WC-3320	BREW CONE W/HANDLE 8.8" D W/STRAINER	24	WC-4394	SHOCK GUARD, HEATING ELEMENT
3A	WC-3311	BREWCONE W/HANDLE COFFEE GEM	25	WC-1438-101*	SENSOR, TEMPERATURE TANK
4	WC-3201	HANDLE, BREWCONE BLACK	26	WC-521*	THERMOSTAT, HIGH LIMIT
5	WC-3358*	BREWCONE ASSY, W/WC-3320, WC-3322 & WC-3647	27	WC-5231*	COMPOUND SILICONE 5 OZ
5A	WC-3325*	BREWCONE ASSEMBLY COFFEE	28	WC-5310*	TUBING, 5/16" ID X 1/8" W SILICONE
6	WC-58117	COVER, TOP BREWER	29	TCO417A000	TEA CONTAINER OVAL 4 GAL 17" (SOLD SEPARATELY)
7	WC-889*	VALVE, DUMP LEFT 120V 12W	29A	TCO419A000	TEA CONTAINER OVAL 4 GAL 19" (SOLD SEPARATELY)
8	WC-2977-01	FITTING ASSY, SPRAYHEAD W/O-RING	29B	TCO421A000	TEA CONTAINER OVAL 4 GAL 21" (SOLD SEPARATELY)
9	WC-37301*	KIT, LABEL & UCM CBGT W/1/2 BREW CURTIS LOGO	30	WC-5683	LID ASSY, TCO
9A	WC-37184	KIT, LABEL & UCM CBGT CURTIS (OLDER UNITS ONLY)	31	WC-38471	LABEL, FRONT TCO ICED TEA GENERIC
10	WC-2942*	SPRAYHEAD, GRAY	32	WC-3724*	KIT, E-Z VIEW REPLACEMENT
11	WC-8562	SPOUT, ASSY BYPASS SCTC	33	WC-1803	FAUCET, SPB
12	WC-8556*	HEAT SINK ASSY DV	34	WC-3707*	KIT, REPAIR SPB FAUCET
12A	WC-6193-0	TRIAC, 40A 600V	35	WC-1805*	SEAT CUP, FAUCET S'
13	WC-801	VALVE, INLET BRASS .5 GPM 120V 10W	36	WC-37260*	KIT, FAUCET W/ADAPTER COMPLETE
13A	WC-826L	VALVE, 1 GPM 120V 10W	37	WC-1809	FAUCET, HOT WATER
13B	WC-85013*	VALVE, SUB ASSEMBLY (OLDER MODELS)	38	WC-3011*	SHELF, ADAPTER
14	WC-58017-101	COVER, CENTER WRAP CBS SHORT	39	WC-4526	SCREW 8-32 x .188 SHOULDER
14A	WC-58021-101	COVER, FRONT CENTER WRAP CBS TALL	40	WC-169*	SWITCH, TEA CONTAINER TRIGGER 1A@125V
15	WC-102*	SWITCH, TOGGLE SPST 25A 125/250VAC RESISTIVE	41	WC-38275	LABEL, PRESS TEA CONTAINER
16	WC-3518*	LEG, GLIDE 3/8"-16 STUD SCREW	42	WC-8531	RAIL, BASE TCTD
18	WC-5851	COVER, TANK W NOTCHES	43	WC-3503*	LEG, 3/8 STUD SCREW BUMPER
19	WC-43062	GASKET, TANK LID	44	WC-3763*	KIT, VALVE REPAIR USE ON WC-889
21	WC-6277	TANK ASSY, COMPLETE TEA BREWER	45	WC-3765L*	KIT, INLET VALVE REPAIR USE ON WC-826L

* Recommended parts to stock

ELECTRICAL SCHEMATIC

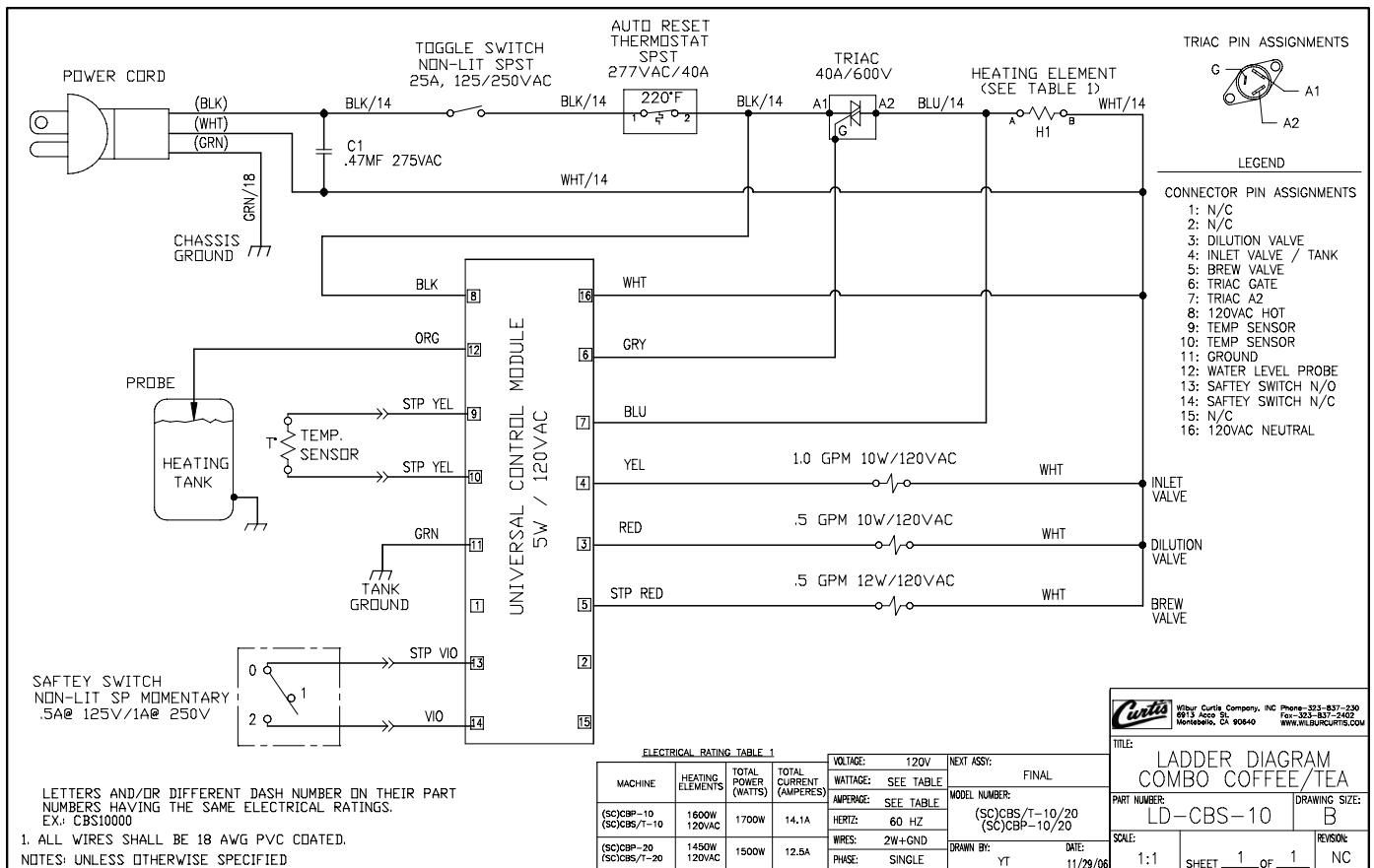

Product Warranty Information

The Wilbur Curtis Company certifies that its products are free from defects in material and workmanship under normal use. The following limited warranties and conditions apply:

- 3 Years, Parts and Labor, from Original Date of Purchase on digital control boards.
- 2 Years, Parts, from Original Date of Purchase on all other electrical components, fittings and tubing.
- 1 Year, Labor, from Original Date of Purchase on all electrical components, fittings and tubing.

Additionally, the Wilbur Curtis Company warrants its Grinding Burrs for Forty (40) months from date of purchase or 40,000 pounds of coffee, whichever comes first. Stainless Steel components are warranted for two (2) years from date of purchase against leaking or pitting and replacement parts are warranted for ninety (90) days from date of purchase or for the remainder of the limited warranty period of the equipment in which the component is installed.

All in-warranty service calls must have prior authorization. For Authorization, call the Technical Support Department at 1-800-995-0417. Effective date of this policy is April 1, 2003.

Additional conditions may apply. Go to www.wilburcurtis.com to view the full product warranty information.

CONDITIONS & EXCEPTIONS

The warranty covers original equipment at time of purchase only. The Wilbur Curtis Company, Inc., assumes no responsibility for substitute replacement parts installed on Curtis equipment that have not been purchased from the Wilbur Curtis Company, Inc. The Wilbur Curtis Company will not accept any responsibility if the following conditions are not met. The warranty does not cover and is void under the following circumstances:

- 1) **Improper operation of equipment:** *The equipment must be used for its designed and intended purpose and function.*
- 2) **Improper installation of equipment:** *This equipment must be installed by a professional technician and must comply with all local electrical, mechanical and plumbing codes.*
- 3) **Improper voltage:** *Equipment must be installed at the voltage stated on the serial plate supplied with this equipment.*
- 4) **Improper water supply:** *This includes, but is not limited to, excessive or low water pressure, and inadequate or fluctuating water flow rate.*
- 5) **Adjustments and cleaning:** *The resetting of safety thermostats and circuit breakers, programming and temperature adjustments are the responsibility of the equipment owner. The owner is responsible for proper cleaning and regular maintenance of this equipment.*
- 6) **Damaged in transit:** *Equipment damaged in transit is the responsibility of the freight company and a claim should be made with the carrier.*
- 7) **Abuse or neglect (including failure to periodically clean or remove lime accumulations):** *Manufacturer is not responsible for variation in equipment operation due to excessive lime or local water conditions. The equipment must be maintained according to the manufacturer's recommendations.*
- 8) **Replacement of items subject to normal use and wear:** *This shall include, but is not limited to, light bulbs, shear disks, "O" rings, gaskets, silicone tube, canister assemblies, whipper chambers and plates, mixing bowls, agitation assemblies and whipper propellers.*
- 9) **Repairs and/or Replacements** *are subject to our decision that the workmanship or parts were faulty and the defects showed up under normal use. All labor shall be performed during regular working hours. Overtime charges are the responsibility of the owner. Charges incurred by delays, waiting time, or operating restrictions that hinder the service technician's ability to perform service is the responsibility of the owner of the equipment. This includes institutional and correctional facilities. The Wilbur Curtis Company will allow up to 100 miles, round trip, per in-warranty service call.*

RETURN MERCHANDISE AUTHORIZATION: *All claims under this warranty must be submitted to the Wilbur Curtis Company Technical Support Department prior to performing any repair work or return of this equipment to the factory. All returned equipment must be repackaged properly in the original carton. No units will be accepted if they are damaged in transit due to improper packaging. **NO UNITS OR PARTS WILL BE ACCEPTED WITHOUT A RETURN MERCHANDISE AUTHORIZATION (RMA). RMA NUMBER MUST BE MARKED ON THE CARTON OR SHIPPING LABEL.** All in-warranty service calls must be performed by an authorized service agent. Call the Wilbur Curtis Technical Support Department to find an agent near you.*



WILBUR CURTIS CO., INC.
6913 Acco St., Montebello, CA 90640-5403 USA
Phone: 800/421-6150 ♦ Fax: 323-837-2410
♦ Technical Support Phone: 800/995-0417 (M-F 5:30A - 4:00P PST) ♦ E-Mail: techsupport@wilburcurtis.com
♦ Web Site: www.wilburcurtis.com

FOR THE LATEST SPECIFICATION INFORMATION GO TO WWW.WILBURCURTIS.COM