



Designation: F 959M – 01

METRIC

## Standard Specification for Compressible-Washer-Type Direct Tension Indicators for Use With Structural Fasteners [Metric]<sup>1</sup>

This standard is issued under the fixed designation F 959M; the number immediately following the designation indicates the year of original adoption or, in the case of revision, the year of last revision. A number in parentheses indicates the year of last reapproval. A superscript epsilon ( $\epsilon$ ) indicates an editorial change since the last revision or reapproval.

### 1. Scope \*

1.1 This specification covers the requirements for compressible-washer-type direct tension indicators capable of indicating the achievement of a specified minimum bolt tension in a structural bolt.

1.2 Two types of direct tension indicators in nominal diameter sizes M16 through M36 are covered:

1.2.1 *Type 8.8*—Direct tension indicators for use with Specification A 325M bolts, and

1.2.2 *Type 10.9*—Direct tension indicators for use with Specification A 490M bolts.

1.3 Direct tension indicators are intended for installation under either a bolt head or a hardened washer. (See Appendix X1.)

1.4 The following precautionary statement pertains only to the test methods portion, Section 12, Annex A1, and Appendix X1 of this specification: *This standard does not purport to address all of the safety concerns, if any, associated with its use. It is the responsibility of the user of this standard to establish appropriate safety and health practices and determine the applicability of regulatory limitations prior to use.*

### 2. Referenced Documents

#### 2.1 ASTM Standards:

A 325M Specification for Structural Bolts, Steel, Heat-Treated, 120/105 ksi Minimum Tensile Strength [Metric]<sup>2</sup>

A 490M Specification for High-Strength Steel Bolts, Classes 10.9 and 10.9.3, for Structural Steel Joints [Metric]<sup>2</sup>

A 563 Specification for Carbon and Alloy Steel Nuts<sup>2</sup>

B 695 Specification for Coatings of Zinc Mechanically Deposited on Iron and Steel<sup>2</sup>

D 3951 Practice for Commercial Packaging<sup>3</sup>

E 4 Practices for Load Verification of Testing Machines<sup>4</sup>

F 436M Specification for Hardened Steel Washers [Metric]<sup>2</sup>

F 1470 Guide for Fastener Sampling for Specified Mechanical Properties and Performance Inspection<sup>2</sup>

2.2 *Research Council on Structural Connections Standard: Specification for Structural Joints Using ASTM A 325 or A 490 Bolts*<sup>5</sup>

2.3 *ANSI Standards*:<sup>6</sup>

B 18.2.3.7M Metric Heavy Hex Structural Bolts

B 18.2.3.4.6M Metric Heavy Hex Nuts

### 3. Terminology

#### 3.1 Definitions of Terms Specific to This Standard:

3.1.1 *compressible-washer-type direct tension indicator*—a washer-type element inserted under the bolt head or hardened washer, having the capability of indicating the achievement of a required minimum bolt tension by the degree of direct tension indicator plastic deformation. Hereinafter referred to as *direct tension indicator*.

### 4. Ordering Information

4.1 Orders for direct tension indicators under this specification shall include the following:

4.1.1 Quantity (number of pieces);

4.1.2 Name of product (direct tension indicator);

4.1.3 Size, that is, nominal diameter;

4.1.4 ASTM designation and year of issue, if not specified, current issue shall be used;

4.1.5 Type required, 8.8 or 10.9 (see 1.2);

4.1.6 Coating type, if required (see 5.4);

4.1.7 Source inspection, if required (Section 13);

4.1.8 Certificates of compliance or test reports, if required (Section 15); and

<sup>1</sup> This specification is under the jurisdiction of ASTM Committee F16 on Fasteners and is the direct responsibility of Subcommittee F16.02 Steel Bolts, Nuts, Rivets, and Washers.

Current edition approved Apr. 10, 2001. Published June 2001. Originally published as F 959M – 94. Last previous edition F 959M – 99a.

<sup>2</sup> *Annual Book of ASTM Standards*, Vol 01.08.

<sup>3</sup> *Annual Book of ASTM Standards*, Vol 15.09.

<sup>4</sup> *Annual Book of ASTM Standards*, Vol 03.01.

<sup>5</sup> Available from Research Council on Structural Connections, c/o Industrial Fasteners Institute, 1717 East 9th Street, Cleveland, OH 44114.

<sup>6</sup> Available from American National Standards Institute, 11 West 42nd St., 13th Floor, New York, NY 10036.

\*A Summary of Changes section appears at the end of this standard.

4.1.9 Any special requirements.

## 5. Materials and Manufacture

5.1 Steel used in the manufacture of direct tension indicators shall be produced by the basic-oxygen or electric-furnace process.

### 5.2 Design:

5.2.1 Direct tension indicators shall have a configuration produced by extrusion, punching, pressing, or similar forming, to permit a measurable decrease in thickness when placed in compression.

5.2.2 The design shall be such that the degree of plastic deformation shall indicate the tension in a tightened structural bolt.

5.3 *Heat Treatment*—The process used for heat treatment of DTIs shall be through-hardening by heating to a temperature above the upper transformation temperature, quenching in a liquid medium, and then retempering by reheating to a suitable temperature to attain desired mechanical/performance properties.

### 5.4 Protective Coatings:

5.4.1 Unless otherwise specified, the direct tension indicators shall be furnished “plain,” with the “as fabricated” surface finish without protective coatings.

5.4.2 When “zinc coated” is specified, the direct tension indicators shall be zinc coated by the mechanical deposition process in accordance with the requirements of Class 50 of Specification B 695.

5.4.3 When “baked epoxy” is specified, the epoxy shall be 0.025 to 0.05-mm thick applied over the zinc coating specified in 5.4.2. The epoxy shall not flake off exposed surfaces during installation.

5.4.4 Other coatings are to be used only when approved by the direct tension indicator manufacturer.

## 6. Chemical Composition

6.1 The direct tension indicators shall conform in chemical composition to the limits given in Table 1.

6.2 Product analysis may be made by the purchaser from finished direct tension indicators representing each lot. The chemical composition shall conform to the requirements given in Table 1, Product Analysis.

## 7. Performance Requirements

7.1 *Compression Loads*—Direct tension indicators shall be tested in accordance with Annex A1 of this specification. When compressed to the gap specified in Table 2, the compression load shall conform to the requirements specified in Table 3.

**TABLE 1 Chemical Requirements**

Element	Composition, %	
	Heat Analysis	Product Analysis
Carbon	0.30–0.50	0.27–0.53
Manganese	0.50–0.90	0.47–0.93
Phosphorus, max	0.035	0.043
Sulfur, max	0.040	0.048
Silicon	0.15–0.35	0.13–0.37

**TABLE 2 Direct Tension Indicator Gap for Compression Load Testing**

Direct Tension Indicator Finish	Gap, mm	
	Specification 8.8	Specification 10.9
Plain finish	0.4	0.4
Mechanically galvanized	0.4	...
Baked epoxy coating on		
Mechanically deposited zinc	0.4	...

**TABLE 3 Acceptable Range of Compression Loads**

Direct Tension Indicator Size (Nominal Diameter, mm)	Compression Load Range, kN	
	Type 8.8	Type 10.9
M16	91–109	114–131
M 20	142–170	179–206
M 22	176–211	221–254
M 24	205–246	257–296
M 27	267–320	334–384
M 30	326–391	408–469
M 36	475–570	595–684

7.2 *Bolt Tension*—See Appendix X1 for field tests to ensure that the desired minimum bolt tension has been achieved.

## 8. Dimensions

8.1 The direct tension indicators shall conform to the dimensions specified in Table 4.

## 9. Workmanship, Finish, and Appearance

9.1 The direct tension indicators shall be commercially smooth and free of injurious material or manufacturing defects that would affect their performance.

## 10. Number of Tests and Retests

### 10.1 Responsibility:

10.1.1 The direct tension indicator manufacturer shall inspect each lot of direct tension indicators prior to shipment in accordance with the quality assurance procedures described in 10.2.

10.1.2 The purpose of a lot inspection testing program is to ensure that each lot conforms to the requirements of this specification. For such a plan to be fully effective, it is essential that the purchaser continue to maintain the identification and integrity of each lot following delivery until the product is installed in its service application.

### 10.2 Production Lot Method:

10.2.1 All direct tension indicators shall be processed in accordance with a lot identification control-quality assurance plan. The manufacturer shall identify and maintain the integrity of each production lot of direct tension indicators from raw material selection through all processing operations and treatments to final packing and shipment. Each lot shall be assigned its own lot-identification number, each lot shall be tested, and the inspection test reports for each lot shall be retained.

10.2.2 For purposes of assigning an identification number and from which test samples shall be selected, a production lot, shall consist of all direct tension indicators processed essentially together through all operations to placing in the shipping

**TABLE 4 Dimensions of Direct Tension Indicators**

Direct Tension Indicator Size (Nominal Diameter, mm) <sup>A</sup>	Type 8.8					Type 10.9					All Types		
	Outside Diameter (OD), mm		Number of Protrusions (Equally Spaced)	Thickness, mm		Outside Diameter (OD), mm		Number of Protrusions (Equally Spaced)	Thickness, mm		Inside Diameter (ID), mm		Protrusion Tangential Diameter (PTD), max, mm (see Fig. 1)
	min	max		Without Protrusion, min	With Protrusion, max	min	max		Without Protrusion, min	With Protrusion, max	Uncoated		
										min	max		
M16	35.2	36.8	4	3.2	5.5	35.2	36.8	4	3.6	6.0	16.75	16.85	25
M 20	44.0	46.0	5	3.6	6.0	44.0	46.0	6	3.6	6.0	20.95	21.05	29
M 22	48.4	50.6	5	3.6	6.0	48.4	50.6	6	4.0	7.0	23.05	23.15	33
M 24	52.8	55.2	5	4.0	7.0	52.8	55.2	6	4.0	7.0	25.15	25.25	38
M 27	59.4	62.1	6	4.0	7.0	59.4	62.1	7	4.0	7.0	28.30	28.40	43
M 30	66.0	69.0	7	4.0	7.0	66.0	69.0	8	4.8	7.5	31.45	31.55	46.5
M 36	79.2	82.8	8	4.8	7.5	79.2	82.8	9	4.8	7.5	37.75	37.85	56

<sup>A</sup> Nominal direct tension indicator sizes are intended for use with fasteners of the same nominal diameter.

container that are of the same nominal size, produced from the same mill heat of steel, and heat treated in the same heat treatment cycle.

10.2.3 The minimum number of samples to be tested to determine compression loads and coating thickness (when applicable) shall be in accordance with the requirements specified in Guide F 1470.

10.3 *Number of Tests After Alterations*— If direct tension indicators are heat treated, coated, or otherwise altered by a subcontractor or manufacturer subsequent to testing, they shall be tested in accordance with 10.2 prior to shipment to the purchaser after all alterations have been completed.

## 11. Specimen Preparation

11.1 Indicators for tests shall be tested full size“ as received,” without any special preparation.

11.2 All test specimens shall conform to the values given in Table 3, regardless of surface coating (lubricants included).

## 12. Test Methods

12.1 Compression load tests shall be conducted in accordance with Annex A1 of this specification.

## 13. Inspection

13.1 If the inspection described in 13.2 is required by the purchaser, it shall be specified in the inquiry and contract or order.

13.2 The purchaser’s quality assurance representative shall have free entry to all parts of the manufacturer’s works that concern the manufacture of the direct tension indicators ordered. The manufacturer shall afford the quality assurance representative all reasonable facilities to satisfy him that the direct tension indicators are being furnished in accordance with this specification. All tests and inspections required by this specification that are requested by the purchaser’s representative shall be made before shipment and shall be conducted so as not to interfere unnecessarily with the operation of the plant.

## 14. Rejection

14.1 Direct tension indicators that fail to conform to the requirements of this specification shall be rejected. Rejection should be reported to the producer or supplier promptly and in writing. In case of dissatisfaction with the results of the test, the producer or supplier may make claim for a rehearing.

## 15. Certification

15.1 When specified on the order, the manufacturer shall furnish a test report as described in 15.2 or a certificate of compliance as described in 15.3, whichever is required.

15.2 When test reports are required, the manufacturers shall furnish a test report for each production lot from which direct tension indicators are supplied to fill a shipment. The report shall show the heat number (to ensure that the chemical composition is on record and could be furnished upon request), compression test loads, measured thickness of protective coatings, gap, nominal size, production lot identification number, ASTM designation, type and issue date, and purchase order number.

15.3 When certificates of compliance are required, the manufacturer shall furnish a certificate certifying that the indicators have been manufactured and tested and conform to the requirements of this specification. The certificate shall show the production lot identification number, nominal size, ASTM designation, type and issue date, and purchase order number.

## 16. Responsibility

16.1 The party responsible for the direct tension indicator shall be the organization that supplies the direct tension indicator to the purchaser and certifies that the direct tension indicator was manufactured, sampled, tested, and inspected in accordance with this specification and meets all of its requirements.

## 17. Product Marking

17.1 Each direct tension indicator shall be marked to identify the lot number, manufacturer or private label distribution, as appropriate, and type (see 1.2).

17.2 All markings shall be depressed on the same face of the direct tension indicators as the protrusions. Raised markings are prohibited.

17.3 All direct tension indicators shall have circumferential indentations spaced equally around the outside circumference, corresponding to and in alignment with each feeler gage entry space. Indentations shall be clearly visible but not so large as to interfere with the function of the direct tension indicator. (See Fig. 1).

17.3.1 The circumferential indentations indicate where the feeler gage must be inserted.

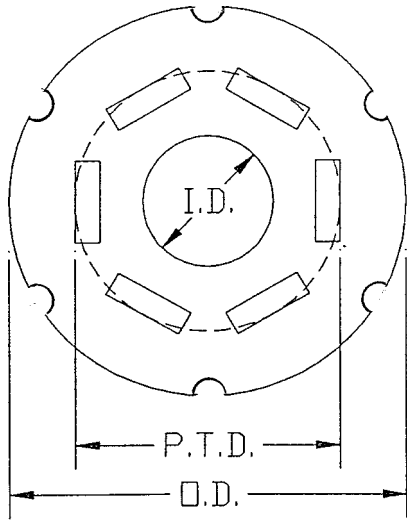

**DIRECT TENSION INDICATOR**

**FIG. 1 Direct Tension Indicator Protrusion Tangential Diameter (PTD)**

## 18. Packaging and Package Marking

### 18.1 Packaging:

18.1.1 Unless otherwise specified, packaging shall be in accordance with Practice D 3951.

18.1.2 Packaging shall be performed as soon as practical

following final testing.

18.1.3 When special packaging requirements are required, they shall be defined at the time of the inquiry and order.

### 18.2 Package Marking:

18.2.1 Each shipping unit shall include or be marked plainly with the following information:

18.2.1.1 ASTM designation and type,

18.2.1.2 Size,

18.2.1.3 Name and brand or trademark of the manufacturer or private label distributor,

18.2.1.4 Number of pieces,

18.2.1.5 Purchase order number,

18.2.1.6 Name of product,

18.2.1.7 Lot identification number, and

18.2.1.8 Finish,

18.2.1.9 Country of origin.

## 19. Storage

19.1 The direct tension indicators shall be stored in an environment that preserves the surface condition supplied by the manufacturer.

## 20. Keywords

20.1 compressible-washer-type; direct tension indicators; DTI; indicators

## ANNEX

### (Mandatory Information)

#### A1. TEST METHOD FOR MEASURING COMPRESSION LOADS (ALL FINISHES)

##### A1.1 Testing Apparatus

A1.1.1 Test the direct tension indicators in an apparatus described herein that is capable of determining their performance characteristics with sufficient accuracy.

A1.1.2 Testing apparatus shall include a compression loading system, top and bottom bearing blocks, and support blocks that allow each direct tension indicator to be calibrated using a direct reading gage.

A1.1.3 The testing apparatus shall conform to the requirements of Practices E 4. The loads used in determining compressive loads shall be within the verified loading range of the testing machine in accordance with Practices E 4.

A1.1.4 The direct reading gage of the testing apparatus shall be capable of measuring the gap variation to within 0.0125 mm.

NOTE A1.1—Because of acceptable variations in bolt dimensions and coating characteristics, bolts cannot be used as a means of gaging the direct tension indicator measured minimum and maximum performance.

##### A1.2 Compression Loading System

A1.2.1 The compression loading system shall transmit a compressive load axially from the testing apparatus to the

direct tension indicator. The bottom bearing block of the loading system must be able to accept the cylindrical protrusions of the direct tension indicator support blocks.

A1.2.2 Maintain the compression loading system in good operating condition and use only in the proper loading range.

##### A1.3 Support Blocks

A1.3.1 Support blocks shall be grooved on one side so that the direct reading gage can be zeroed without compressing the direct tension indicator protrusions. (See Fig. A1.1.) Thus, the exact thickness of the direct tension indicator being tested is taken into account, and the flat surface of the side of the direct tension indicator having protrusions is made to relate exactly to

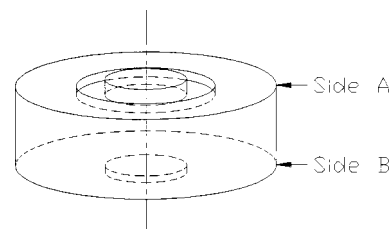

**FIG. A1.1 Support Block**

the zero point of the gage that shall react on the center of the direct tension indicator support block.

A1.3.2 Support blocks shall have a minimum Rockwell hardness of 50 HRC.

A1.3.3 Support blocks shall conform to the dimensions shown in Fig. A1.2.

A1.3.4 The surfaces of support blocks shall be parallel to within 0.005 mm across the diameter of the support block.

#### A1.4 Bearing Blocks

A1.4.1 The upper bearing block shall have a minimum diameter of 75 mm.

A1.4.2 Bearing blocks shall have a minimum Rockwell hardness of 50 HRC.

A1.4.3 The upper and bottom bearing block surfaces shall be parallel to within 0.0125 mm across the width of the support block.

#### A1.5 Calibration

A1.5.1 Calibrate the testing apparatus and its direct reading gage at least once per year.

A1.5.2 Retain the calibrated test data.

#### A1.6 Test Procedure

A1.6.1 Select the support block corresponding to the size and type of direct tension indicator to be tested.

A1.6.2 The direct reading gage spindle shall be in contact with the center of the direct tension indicator support block during the test. (See Fig. A1.3.)

A1.6.3 *Zero Direct Reading Gage*—Place the direct tension indicator, with protrusions facing down, into the grooves of the support block. Apply compression load equal to the minimum required load for the size and type of direct tension indicator being tested. Set the direct reading gage at zero. Release the load and remove the direct tension indicator. See Step 1 of Fig. A1.3.

A1.6.4 Invert the support block so that Side A with the groove is facing down.

A1.6.5 *Measure Compression Load*:

A1.6.5.1 Place the flat surface of the direct tension indicator against Side B of the support block with protrusions facing up. Apply compression load until the gage reading is the test gap specified in this specification for the size, type, and surface condition of the direct tension indicator being tested. See Step 2 of Fig. A1.3.

A1.6.5.2 Apply the compression load at a rate such that the direct tension indicator is compressed within 30 s from the time the compression load is first applied until the proper gap is achieved.

A1.6.6 *Read and Record*—Read the compression load within 5 s of reaching the test gap and record the results.

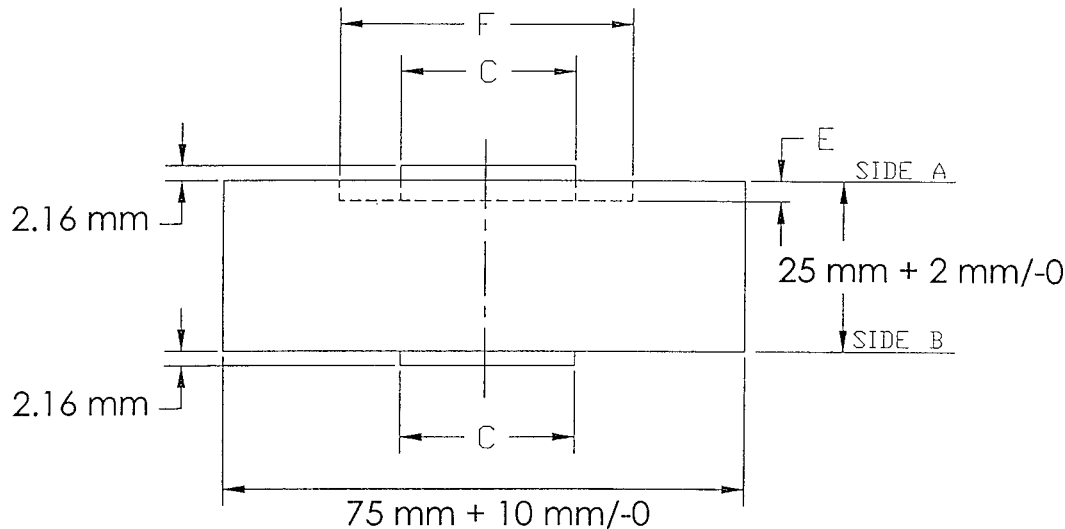

Size	C mm		E mm		F mm	
	max	min	min	max	min	max
M16	15.5	15	3	30	30.5	30.5
M 20	19.5	19	3	34	34.5	34.5
M 22	21.5	21	3	38	38.5	38.5
M 24	23.5	23	3	43	43.5	43.5
M 27	26.5	26	3	49	49.5	49.5
M 30	29.5	29	3	53.5	54	54
M 36	35.5	35	3	63	63.5	63.5

NOTE 1—{Height of boss = 2.16 mm +0/-0.0125 mm with no more than 0.005 mm difference between side "A" and side "B".}

**FIG. A1.2 Support Block Dimensions**

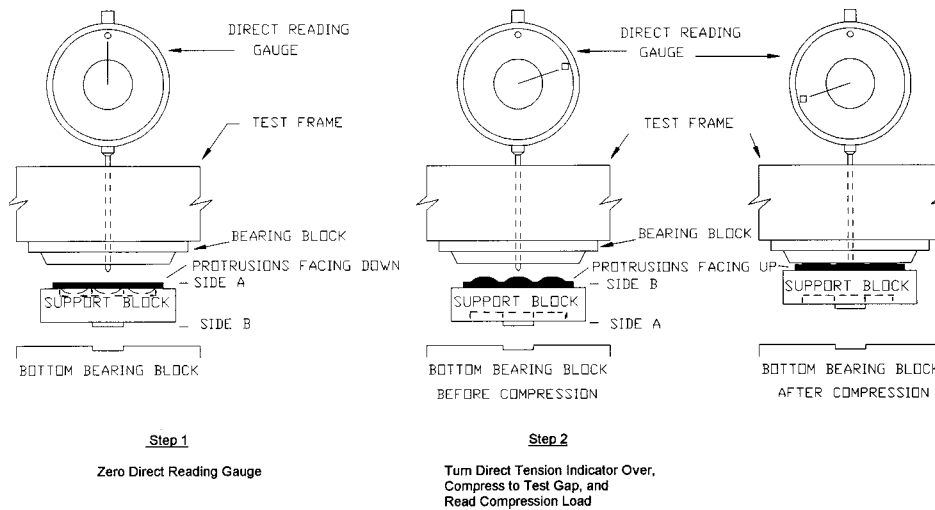

FIG. A1.3 Steps for Determining Compression Load

## APPENDIX

### (Nonmandatory Information)

#### X1. FIELD TESTING OF DIRECT TENSION INDICATORS FOR BOLT TENSION

##### X1.1 Test Rationale

X1.1.1 The following testing procedure is recommended for the user in the field. The bolt load tolerances take account of expected variables in the accompanying fastener assemblies. Properly executed, it should provide the user with an assurance that:

X1.1.1.1 The lot of direct tension indicators being tested indicates the desired minimum bolt tension has been achieved after installation to the project gaps (0.4 or 0.125 mm). Also, an acceptable control of a maximum bolt load is ensured;

X1.1.1.2 The lot of direct tension indicators is compatible with dimensionally correct fasteners and applicable coatings; and

X1.1.1.3 The complete fastener assembly, with properly lubricated threads, is functioning when used in conjunction with the direct tension indicator.

##### X1.2 Test Equipment

X1.2.1 *Bolt Tension Calibrators*—Acceptable devices should provide accurate readings of the induced bolt tension, which should be developed by rotation of either the nut or bolt head. A calibration certificate less than six months old must be in evidence at the test site. Care should be taken to record the peak load on the dial indicator of the calibrator immediately to avoid a false reading after fall-back of the needle on the dial occurs.

X1.2.2 *Bolts, Nuts, and Hardened Washers*—Dimensions, hardnesses, strengths, and coatings must be in accordance with relevant ASTM (Specifications A 325M, A 490M, A 563, and F 436M) and ANSI (B18.2.3.7M and B18.2.3.4.6M) standards.

X1.2.3 *Wrenches*—Tensioning of the bolts shall be accomplished with a hand wrench so that the tension readings can be

recorded exactly. The use of a torque multiplier or a handle extension may be necessary and is acceptable.

##### X1.3 Direct Tension Indicator Assemblies

X1.3.1 Test direct tension indicators in the field on a calibrated bolt tension calibrator in accordance with Fig. X1.1, using face plates with standard hole sizes.

##### X1.4 Testing for Proper Gap Compliance

X1.4.1 *Gap Under Bolt Head, 0.4 mm*—Plain finish direct tension indicator only, assembled under bolt head (see Fig. X1.1). *Gap Under Bolt Head, 0.125 mm*, zinc, or epoxy-coated direct tension indicator only, assembled under bolt head (see Fig. X1.1). *Gap Under Turned Element, 0.125 mm*, plain finish direct tension indicator only, assembled under hardened washer beneath turned element (see Fig. X1.1).

X1.4.1.1 *Testing Procedure*—Tighten the bolt until the tension reading on the calibrator dial is the minimum required bolt tension for the bolt being tested. (See Column 1 of Table X1.1.) Ensure that the applicable feeler gage fits in at least the number of entry spaces in Table X1.2. Continue tightening the bolt until the point at which the feeler gage refuses to enter the number of refusal spaces also in Table X1.2. The tension in the bolt as measured by the calibrator must be less than the minimum ultimate tensile strength of the bolt as given in Table X1.1, Column 2. At this point, the assembly has demonstrated the ability to compress the bumps to the gap required in the work without exceeding the minimum ultimate tensile strength of the bolt.

X1.4.2 *Alternate Project Gaps*—Project gaps at dimensions smaller than those detailed in X1.4.1 are permissible, provided that it can be demonstrated that there has been no detrimental plastic deformation in the body of the bolt after assembly in the

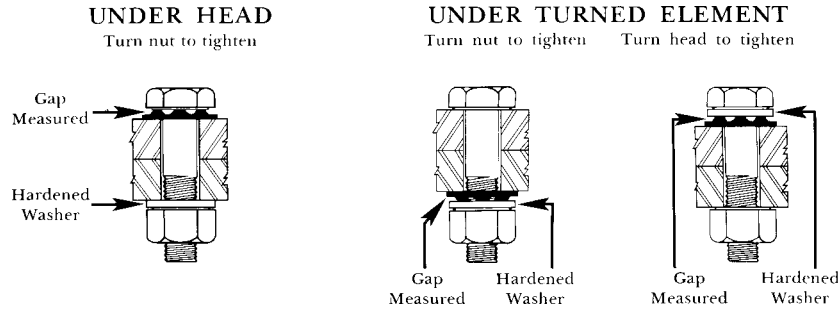

NOTE 1—The use of flat hardened washes to Specification F 436M in accordance with Specification for Structural Joints Using ASTM A 325 or A 490 Bolts varies with correct bolt strength, hole size, and yield strength of connected steel and is not reflected in this figure.

FIG. X1.1 Assembly of Indicator for Bolting Installations

TABLE X1.1 Minimum Tensions and Ultimate Tensile Strengths for Specifications A 325M and A 490M Bolts

Bolt Size Nominal, mm	Column 1, Minimum Required Bolt Tension, <sup>A</sup> min, kN		Column 2, Minimum Specified Ultimate Tensile Strength of Bolt from Specifications A 325M and A 490M, min, kN	
	Specification A 325M	Specification A 490M	Specification A 325M	Specification A 490M
M16	91	114	130	163
M 20	142	179	203	255
M 22	176	221	251	315
M 24	205	257	293	367
M 27	267	334	381	477
M 30	326	408	466	583
M 36	475	595	678	850

<sup>A</sup> Excerpt from Specification for Structural Joints Using ASTM A 325 or A 490 Bolts. Approved by the Research Council on Structural Connections of the Engineering Foundation.

TABLE X1.2 Minimum Number of Feeler Entries/Refusals

Number of Indicator Protrusions	
4	2
5	3
6	3
7	4
8	4
9	5

testing apparatus. The ability of the nut to travel the complete thread length after tightening should provide sufficient assurance of this.

**X1.5 Bolt Body Diameters**

X1.5.1 Direct tension indicators are manufactured with an internal diameter larger than the maximum body diameter

given in ANSI B18.2.3.7M for heavy hex structural bolts. Certain hot-forged heavy hex structural bolts are made with tooling that creates a “swell” or seam under the head during the forging operation. ANSI B18.2.3.7M states in Note 10.2 that a maximum diameter change is permitted above the basic bolt diameter. There is potential for the inside diameter of a direct tension indicator to interfere with this allowable swell over the basic bolt body diameter at the underside of the bolt head. The direct tension indicator should be used under a hardened washer in such rarely encountered cases. With cold-forged bolts, no interference is encountered, including with the fillet radius at the specified gap of 0.125 mm; and the previously described field test will confirm that proper fit has not been a problem.

**SUMMARY OF CHANGES**

This section contains the principle changes to the standard that have been incorporated since the last issue.

- (1) Revised 10.2.3 to invoke F 1470 for testing frequency.
- (2) Deleted 10.2.4 because its requirements are in F 1470.
- (3) Revised 12.1 to specifically cite *compression* load tests.
- (4) Revised 15.2 to change “test loads” to compression load tests” and add “measured thickness of protective coatings”.

*The ASTM International takes no position respecting the validity of any patent rights asserted in connection with any item mentioned in this standard. Users of this standard are expressly advised that determination of the validity of any such patent rights, and the risk of infringement of such rights, are entirely their own responsibility.*

*This standard is subject to revision at any time by the responsible technical committee and must be reviewed every five years and if not revised, either reapproved or withdrawn. Your comments are invited either for revision of this standard or for additional standards and should be addressed to ASTM International Headquarters. Your comments will receive careful consideration at a meeting of the responsible technical committee, which you may attend. If you feel that your comments have not received a fair hearing you should make your views known to the ASTM Committee on Standards, at the address shown below.*

*This standard is copyrighted by ASTM International, 100 Barr Harbor Drive, PO Box C700, West Conshohocken, PA 19428-2959, United States. Individual reprints (single or multiple copies) of this standard may be obtained by contacting ASTM at the above address or at 610-832-9585 (phone), 610-832-9555 (fax), or [service@astm.org](mailto:service@astm.org) (e-mail); or through the ASTM website ([www.astm.org](http://www.astm.org)).*