



Standard Test Methods for Sealants and Fillers, Hot-Applied, for Joints and Cracks in Asphaltic and Portland Cement Concrete Pavements¹

This standard is issued under the fixed designation D 5329; the number immediately following the designation indicates the year of original adoption or, in the case of revision, the year of last revision. A number in parentheses indicates the year of last reapproval. A superscript epsilon (ε) indicates an editorial change since the last revision or reapproval.

1. Scope

1.1 These test methods cover tests for hot-applied types of joint and crack sealants and fillers for portland cement concrete and asphaltic concrete pavements. There are numerous standard material specifications that use these test methods. Refer to the respective standard material specification of interest to determine which of the following test methods to use. For sample melting and concrete block preparation see their respective standard practices.

1.2 The test methods appear in the following sections:

	Section
Artificial Weathering	15
Asphalt Compatibility	14
Bond, Non-Immersed	9
Bond, Fuel-Immersed	11
Bond, Water-Immersed	10
Cone Penetration, Non-Immersed	6
Cone Penetration, Fuel-Immersed	7
Flexibility	18
Flow	8
Resilience	12
Resilience, Oven-Aged	13
Solubility	17
Tensile Adhesion	16

1.3 The values stated in SI units are to be regarded as the standard. The values given in parentheses are provided for information purposes only.

1.4 *This standard does not purport to address all of the safety concerns, if any, associated with its use. It is the responsibility of the user of this standard to establish appropriate safety and health practices and determine the applicability of regulatory limitations prior to use.*

2. Referenced Documents

2.1 ASTM Standards:²

C 1442 Practice for Conducting Tests on Sealants Using

Artificial Weathering Apparatus

D 5 Test Method for Penetration of Bituminous Materials
D 217 Test Methods for Cone Penetration of Lubricating Grease

D 471 Test Method for Rubber Property-Effect of Liquids
D 1074 Test Method for Compressive Strength of Bituminous Mixtures

D 1561 Practice for Preparation of Bituminous Mixture Test Specimens by Means of California Kneading Compactor
D 1985 Practice for Preparing Concrete Blocks for Testing Sealants, for Joints and Cracks

D 3381 Specification for Viscosity-Graded Asphalt Cement for Use in Pavement Construction

D 5167 Practice for Melting of Hot-Applied Joint and Crack Sealant and Filler for Evaluation

D 6690 Specification for Joint and Crack Sealants, Hot Applied, for Concrete and Asphalt Pavements

E 145 Specification for Gravity-Convection and Forced-Ventilation Ovens

E 171 Specification for Standard Atmospheres for Conditioning and Testing Flexible Barrier Materials

G 23 Practice for Operating Light-Exposure Apparatus (Carbon-Arc Type) With and Without Water for Exposure of Nonmetallic Material³

G 151 Practice for Exposing Nonmetallic Materials in Accelerated Test Devices that Use Laboratory Light Sources

G 153 Practice for Operating Enclosed Carbon Arc Light Apparatus for Exposure of Nonmetallic Materials

G 154 Practice for Operating Fluorescent Light Apparatus for UV Exposure of Nonmetallic Materials

G 155 Practice for Operating Xenon Arc Light Apparatus for Exposure of Non-Metallic Materials

3. Significance and Use

3.1 These test methods describe procedures for determining specification conformance for hot-applied, field-molded joint and crack sealants and fillers.

4. Sample Melting

4.1 See Practice D 5167.

³ Withdrawn.

¹ These test methods are under the jurisdiction of ASTM Committee D04 on Road and Paving Materials and are the direct responsibility of Subcommittee D04.33 on Formed-In-Place Sealants for Joints and Cracks in Pavements.

Current edition approved Feb. 1, 2004. Published February 2004. Originally approved in 1992. Last previous edition approved in 1996 as D 5329-96.

² For referenced ASTM standards, visit the ASTM website, www.astm.org, or contact ASTM Customer Service at service@astm.org. For *Annual Book of ASTM Standards* volume information, refer to the standard's Document Summary page on the ASTM website.

5. Standard Conditions

5.1 The laboratory atmospheric conditions, hereinafter referred to as standard conditions, shall be in accordance with Specification E 171 ($23 \pm 2^\circ\text{C}$ ($73.4 \pm 3.6^\circ\text{F}$)).

6. Cone Penetration, Non-Immersed

6.1 *Scope*—This test method covers determination of cone penetration of bituminous joint and crack sealers and fillers.

6.2 *Significance and Use*—The cone penetration, non-immersed is a measure of consistency. Higher values indicate a softer consistency.

6.3 *Apparatus*—Conduct this test using the apparatus described in Test Method D 5, except as specified herein. Use a penetration cone in place of the standard penetration needle. The cone shall conform to the requirements given in Test Methods D 217, except that the interior construction may be modified as desired. The total moving weight of the cone and attachments shall be 150.0 ± 0.1 g.

6.4 *Specimen Preparation*—Pour a portion of the sample prepared in accordance with Practice D 5167 into one 177 mL (6 oz) tin measuring approximately 70 mm in diameter and 45 mm in depth and fill flush with the rim of the tin. Allow the specimen to cure under standard conditions as specified in its respective material specification.

6.5 *Procedure*—Place the specimen in a water bath maintained at $25 \pm 0.1^\circ\text{C}$ ($77 \pm 0.2^\circ\text{F}$) for 2 h immediately before testing. Remove the specimen from the bath and dry the surface. Using the apparatus described in 6.3, make determinations at three locations on 120° radii, and halfway between the center and outside of the specimen. Take care to ensure the cone point is placed on a point in the specimen that is representative of the material itself and is free of dust, water, bubbles or other foreign material. Clean and dry the cone point after each determination.

6.6 *Report*—Average the three results and record the value as the penetration of the specimen in $1/10$ mm units.

6.7 Precision and Bias:

6.7.1 For Specification D 6690 Type I materials, the following precision statement is based on an interlaboratory study of 12 laboratories that tested five different Specification D 6690 Type I materials.

6.7.1.1 *Within Tin*—Single-Operator Precision (for penetration between 40 and 80): The single-operator deviation has been found to be 0.994. Therefore, results of two properly conducted tests by the same operator should not differ by more than three penetration units.

6.7.1.2 *Within and Between Laboratories*—Single-Operator Precision (penetrations 40 to 80): The single-operator standard deviation of a single test (test result is defined as the average of three penetrations) has been found to be 0.924. Therefore, the results of two properly conducted tests by the same operator on the same material should not differ by more than three penetration units.

6.7.1.3 *Multilaboratory Precision*—(penetration 40 to 80): The multilaboratory standard deviation of a single test (test result is defined as the average of three penetrations) has been found to be 3.249. Therefore, the results of two properly

conducted tests in different laboratories should not differ by more than nine penetration units.

6.7.2 For Specification D 6690 Type II materials, the following precision statement is based on an interlaboratory study of eleven laboratories that tested six different Specification D 6690 Type II materials.

6.7.2.1 *Within Tin*—Single-Operator Precision (for penetration between 55 and 85): The single-operator deviation has been found to be 0.974. Therefore, results of two properly conducted tests by the same operator should not differ by more than three penetration units.

6.7.2.2 *Within and Between Laboratories*—Single-Operator Precision (penetrations 50 to 70): The single-operator standard deviation of a single test (test result is defined as the average of three penetrations) has been found to be 1.0865. Therefore, the results of two properly conducted tests by the same operator on the same material should not differ by more than three penetration units.

6.7.2.3 *Single-Operator Precision*—(penetrations 71 to 85): The single-operator standard deviation of a single test (test result is defined as the average of three penetrations) has been found to be 2.237. Therefore, the results of two properly conducted tests by the same operator on the same material should not differ by more than six penetration units.

6.7.2.4 *Multilaboratory Precision*—(penetration 50 to 70): The multilaboratory standard deviation of a single test (test result is defined as the average of three penetrations) has been found to be 5.2609. Therefore, the results of two properly conducted tests in different laboratories should not differ by more than 15 penetration units.

6.7.2.5 *Multilaboratory Precision*—(penetration 71 to 85): The multilaboratory standard deviation of a single test (test result is defined as the average of three penetrations) has been found to be 16.8831. Therefore, the results of two properly conducted tests in different laboratories should not differ by more than 48 penetration units.

7. Cone Penetration, Fuel-Immersed

7.1 *Scope*—This test method covers the determination of cone penetration after immersion in reference fuel.

7.2 *Significance and Use*—The cone penetration is a measure of consistency of the material. Higher penetration values indicate a softer consistency. Large changes in penetration from the cone penetration, non-immersed value indicate a significant effect of the reference fuel on the sealant.

7.3 *Apparatus*—Same as described in 6.3.

7.4 *Specimen Preparation*—Pour a portion of the sample prepared in accordance with Practice D 5167 into one 177 mL (6 oz) tin, then proceed as in 6.4.

7.5 *Specimen Preparation*—Immerse the specimen prepared as described in 6.4 for 24 h in approximately 500 mL (0.53 qt) to provide a minimum of 12 mm cover of clean test fuel conforming to the requirements of Reference Fuel B of Test Method D 471, maintained in a water bath at a constant temperature of $40 \pm 1^\circ\text{C}$ ($120 \pm 2^\circ\text{F}$). Discard the test fuel after each specimen immersion. After the 24 h immersion, dry the specimen under a draft of an approximately 300 mm (12 in.) diameter electric fan at standard conditions for 1 h. The

placement of the fan shall be such as to maintain air velocity of 0.75 to 2.50 m/s (150 to 500 ft/min) over the sample.

7.6 *Procedure*—Test as described in 6.5.

7.7 *Report*—Record as described in 6.6.

7.8 *Precision and Bias*—The precision and bias of this test method for measuring cone penetration are as specified in Section 6.

8. Flow

8.1 *Scope*—This test method measures the amount of flow of bituminous joint and crack sealants when held at a 75° angle at elevated temperatures.

8.2 *Significance and Use*—This test method is a means of measuring the ability of a sealant to resist flow from the joint or crack at high ambient temperatures.

8.3 *Apparatus*:

8.3.1 *Mold*—Construct a mold (see Note 1) 40 mm wide by 60 mm long by 3.2 mm deep (1.57 in. wide by 2.36 in. long by 0.125 in. deep) and place it on a bright tin panel. The tin plate must be free of dirt, oil, and so forth and be between 0.25 to 0.64 mm in thickness (0.010 and 0.025 in. in thickness).

NOTE 1—A release agent should be used to coat molds and spacers to prevent them from bonding to the sealants. Extreme care should be exercised to avoid contaminating the area where the joint sealant makes contact with the blocks. A non-toxic release agent is recommended for this purpose. Two examples that have been found suitable for this purpose are KY jelly (available at drug stores) and a release agent prepared by grinding a mixture of approximately 50 % talc, 35 % glycerine, and 15 % by weight, of a water-soluble medical lubricant into a smooth paste.

8.3.2 *Oven*—Forced draft type conforming to Specification E 145 and capable of controlling its temperature $\pm 1^\circ\text{C}$.

8.4 *Specimen Preparation*—Pour a portion of the sample prepared in accordance with Practice D 5167 for melting samples into the mold described in 8.3. Fill the mold with an excess of material. Allow the test specimen to cool at standard conditions for at least ½ h, then trim the specimen flush with the face of the mold with a heated metal knife or spatula and remove the mold. Allow the specimen to cure under standard conditions as specified in its respective material specification.

8.5 *Procedure*—Mark reference lines on the panel at the bottom edge of the sealant. Then place the panel containing the sample in a forced-draft oven maintained for the time and at the temperature specified in its respective material specification. During the test, mount the panel so that the longitudinal axis of the specimen is at an angle of $75 \pm 1^\circ$ with the horizontal, and the transverse axis is horizontal. After the specified test period, remove the panel from the oven and measure the movement of the specimen below the reference lines in millimetres.

8.6 *Report*—Report the measurement obtained in 8.5 in millimetres.

8.7 *Precision and Bias*:

8.7.1 For Specification D 6690 Type I materials, the following precision statement is based on an interlaboratory study of 12 laboratories that tested five different Specification D 6690 Type I materials.

8.7.1.1 *Single-Operator Precision (flow 0 to 5)*—The single-operator standard deviation has been found to be 0.255. Therefore, the results of two properly conducted tests by the same operator should not differ by more than one flow unit.

8.7.1.2 *Single-Operator Precision (flow 5 to 10)*—The single-operator standard deviation has been found to be 1.024. Therefore, the results of two properly conducted tests by the same operator should not differ by more than three flow units.

8.7.1.3 *Multilaboratory Precision (flow 0 to 5)*—The multilaboratory standard deviation has been found to be 4.256. Therefore, the results of two properly conducted tests in different laboratories should not differ by more than 12 flow units.

8.7.1.4 *Multilaboratory Precision (flow 5 to 10)*—The multilaboratory standard deviation has been found to be 5.326. Therefore, the results of two properly conducted tests in different laboratories should not differ by more than 15 flow units.

8.7.2 For Specification D 6690 Type II materials, the following precision statement is based on an interlaboratory study of eleven laboratories that tested six different Specification D 6690 Type II materials.

8.7.2.1 *Single-Operator Precision (flow 0 to 1)*—The single-operator standard deviation has been found to be 0.2494. Therefore, the results of two properly conducted tests by the same operator should not differ by more than one flow unit.

8.7.2.2 *Single-Operator Precision (flow 1.1 to 4)*—The single-operator standard deviation has been found to be 0.7616. Therefore, the results of two properly conducted tests by the same operator should not differ by more than three flow units.

8.7.2.3 *Multilaboratory Precision (flow 0 to 1)*—The multilaboratory standard deviation has been found to be 0.5644. Therefore, the results of two properly conducted tests in different laboratories should not differ by more than three flow units.

8.7.2.4 *Multilaboratory Precision (flow 1.1 to 4)*—The multilaboratory standard deviation has been found to be 2.3508. Therefore, the results of two properly conducted tests in different laboratories should not differ by more than seven flow units.

9. Bond, Non-Immersed

9.1 *Scope*—This test method is used to evaluate the bond to concrete.

9.2 *Significance and Use*—Bond to concrete is necessary for a sealant to maintain proper field performance.

9.3 *Apparatus*:

9.3.1 *Extension Machine*—The extension machine used in the bond test shall be so designed that the specimen can be extended a minimum of 12.5 mm (0.5 in.) at a uniform rate of 3.1 ± 0.3 mm (0.125 ± 0.010 in.) per hour. It shall consist essentially of one or more screws rotated by an electric motor through suitable gear reductions. Self aligning plates or grips, one fixed and the other carried by the rotating screw or screws, shall be provided for holding the test specimen in position during the test.⁴

9.3.2 *Cold Chamber*—The cold chamber shall be capable of maintaining the required cold test temperature within $\pm 1^\circ\text{C}$.

9.4 *Concrete-Block Preparation*:

⁴ A machine suitable for testing a minimum of three specimens simultaneously can be obtained from such sources as Applied Test Systems of Butler, PA.

9.4.1 The concrete blocks shall be prepared in accordance with Practice D 1985.

9.5 Specimen Preparation:

9.5.1 Prepare three test specimens (3 specimens \times 2 = 6 blocks) as follows: On removal from the storage water, again scrub the 50 by 75-mm (2 by 3-in.) saw-cut faces of the blocks under running water. When this operation is completed on individual blocks, again place them under clean, fresh water until all blocks to be used are prepared. When all blocks are scrubbed, remove them from the water and lightly blot them with an oil-free, soft, absorbent cloth or paper to remove all free surface water and condition them according to their respective material specification.

9.5.2 Take these blocks and mold the test specimen between them as follows (see Fig. 1): Place four treated (see Note 1) brass or TFE-fluorocarbon spacer strips, approximately 6 mm ($\frac{1}{4}$ in.) thick, on a treated metal plate base to enclose an open space according to the width specified in the respective material specification by 50 mm (2 in.) long. Place the blocks on the spacer strips and space them the required width \pm 0.1 mm (\pm 0.005 in.) apart by means of other treated brass or TFE-fluorocarbon spacer strips, of the required width placed at such distances from the ends that an opening is of the required width by 50.80 ± 0.13 mm by 50.80 ± 0.13 mm (required width by 2.000 ± 0.005 in. by 2.000 ± 0.005 in.) is formed between the blocks with a 6.4-mm ($\frac{1}{4}$ -in.) opening below the blocks.

9.5.3 Rubber bands, clamps, or similar suitable means may be used to hold the blocks in position. Place treated brass or TFE-fluorocarbon spacer strip side walls 25 mm (1 in.) high on top of the blocks. Pour material prepared in accordance with Practice D 5167 into the space between the blocks in sufficient quantity to bring flush with the top of the side walls. After the specimen has cooled for at least 2 h, remove the excess material protruding beyond the top and bottom of the blocks by cutting it off with a heated metal knife or spatula. Use extreme care when removing the spacers so as not to damage the sealant. If this spacer removal caused defects, if shrinkage of the material upon cooling reduces its level below the top of the concrete blocks, or if other casting defects are apparent, the specimen shall be discarded. The finished specimen should resemble Fig. 2.

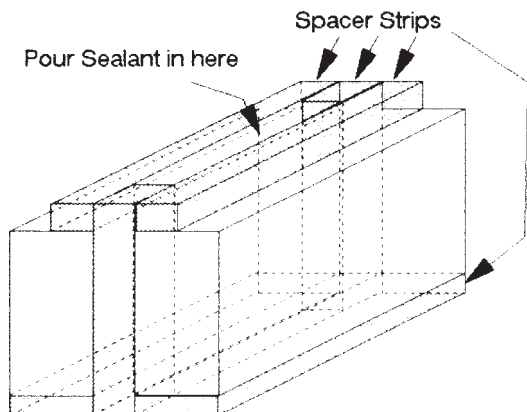

FIG. 1 Concrete Block Mold

9.6 Extension at Low Temperature—Place test specimens, prepared as described in 9.5, in a cold cabinet as described in 9.3.2 for not less than 4 h; then remove the treated spacer blocks and mount the specimens immediately in the self-aligning clamps of the extension machine. Extend the specimens as required by the respective material specification at a uniform rate of 3.1 ± 0.3 mm (0.125 ± 0.010 in.) per hour. During this period, maintain the atmosphere surrounding the test specimens at the temperature specified in the respective material specification. The specimen shall be removed from the test device within 30 min after completing the extension.

9.7 Recompression—After extension as described in 9.6, remove the specimens from the extension machine and immediately examine the specimens for obvious separations within the sealant and between the sealant and the blocks, without distorting or manually causing extension of the specimens. After inspection replace the spacer strips, return to storage at room temperature for 2 h and rest each specimen on one concrete block so that the weight of the top block recompresses the joint sealant.

9.8 Reextension at Low Temperature and Recompression—After recompression repeat the procedure described in 9.6 and 9.7 to complete the number of cycles of extension and recompression as specified in the respective material specification.

9.9 Evaluation of Bond-Test Results—Within 30 min after the last required extension remove the bond test specimens from the extension machine. Immediately examine the specimens, while still frozen, for obvious separations within the sealant and between the sealant and the blocks, without distorting or manually causing extension of the specimens. Determine conformance to the respective material specification.

9.10 Precision and Bias—No information is presented about precision or bias of this test method for bond evaluation since the results are nonquantitative.

10. Bond, Water-Immersed

10.1 Scope—This test method evaluates bond to concrete after immersion in water.

10.2 Significance and Use—Bond to concrete is necessary for a sealant to maintain for proper field performance. Water immersion can have deleterious affects on the bond to concrete.

10.3 Apparatus:

10.3.1 Extension Machine, as described in 9.3.1.

10.3.2 Cold Chamber, as described in 9.3.2.

10.4 Concrete-Block Preparation:

10.4.1 The concrete blocks shall be prepared in accordance with Practice D 1985.

10.5 Specimen Preparation—Prepare three specimens as described in 9.5, replacing the thicker brass or TFE-fluorocarbon spacers with thinner spacers between the concrete blocks so that an opening of not less than 6.4 by 12.7 by 50.8 mm (0.25 by 0.50 by 2 in.) will be produced and maintained between the spacers and the sealant. Then immerse the specimens in suitable covered containers to provide at least a 12.7-mm (0.50-in.) water cover for 96 h in 500 mL (0.53 qt) of distilled or deionized water per specimen and store under standard conditions. Place the specimens in the containers with

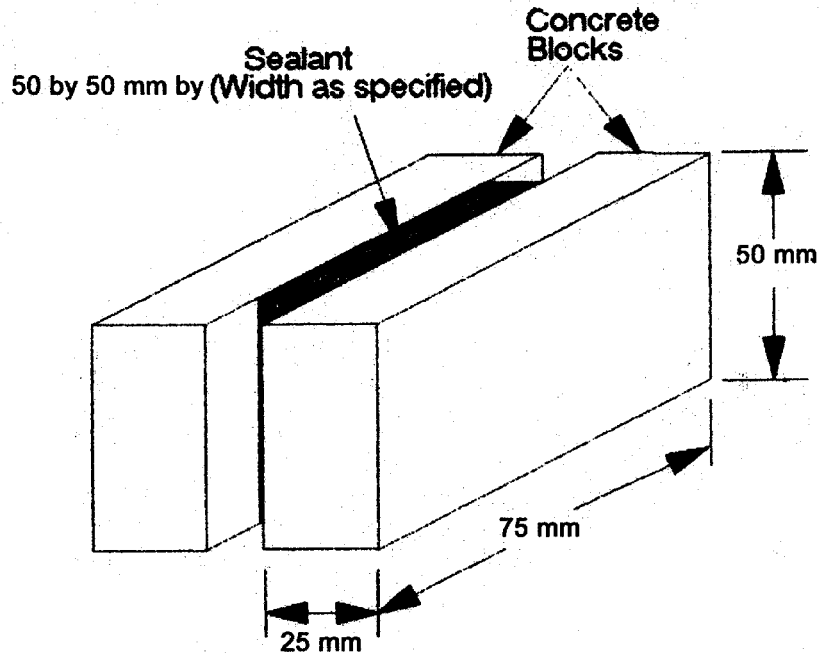

FIG. 2 Concrete Block Test Specimen

the concrete blocks in the horizontal position, resting on the block faces measuring 50 by 76 mm. (2 by 3 in). Three specimens may be placed in one container provided the water to specimen ratio is maintained. At the end of a 96 h water-immersion period, remove the specimens from the water, remove the spacers, and remove the excess surface water from the specimens with a soft, dry, absorbent material. After the surface water has been removed, proceed as described in 9.6.

10.6 *Extension at Low Temperature*—Same as described in 9.6.

10.7 *Recompression*—Same as described in 9.7.

10.8 *Reextension at Low Temperature and Recompression*—Same as described in 9.8.

10.9 *Evaluation of Bond-Test Results*—Same as described in 9.9.

10.10 *Precision and Bias*—No information is presented about precision or bias of this test method for bond evaluation since the results are nonquantitative.

11. Bond, Fuel-Immersed

11.1 *Scope*—This test method evaluates bond to concrete after immersion in reference fuel.

11.2 *Significance and Use*—Bond to concrete is necessary for a sealant to maintain for proper field performance. Fuel immersion, such as could occur on an airport, can have deleterious affects on the bond to concrete.

11.3 *Apparatus:*

11.3.1 *Extension Machine*, as described in 9.3.1.

11.3.2 *Cold Chamber*, as described in 9.3.2.

11.4 *Concrete-Block Preparation:*

11.4.1 The concrete blocks shall be prepared in accordance with Practice D 1985.

11.5 *Specimen Preparation*—Prepare three specimens as described in 9.5, and proceed as required in 10.5 but use a fuel

cover instead of water for 24 h in at least 500 mL (0.53 qt) of clean test fuel conforming to the requirements of Reference Fuel B of Test Method D 471, maintained in a water bath at a constant temperature of $49 \pm 1^\circ\text{C}$ ($120 \pm 2^\circ\text{F}$). Use clean test fuel for each test. At the end of the 24-h immersion period, remove the entire assembly of test specimens, fuel, and containers and condition in an atmosphere at the specified temperature for not less than 4 h. Then subject the specimens to the extension test specified in 9.6.

11.6 *Extension at Low Temperature*—Same as described in 9.6.

11.7 *Recompression*—Same as described in 9.7.

11.8 *Reextension at Low Temperature and Recompression*—Same as described in 9.8.

11.9 *Evaluation of Bond-Test Results*—Same as described in 9.9.

11.10 *Precision and Bias*—No information is presented about precision or bias of this test method for bond evaluation since the results are nonquantitative.

12. Resilience

12.1 *Scope*—This test method measures the ability of a sealant to recover after a steel ball has been forced into the surface.

12.2 *Significance and Use*—The ability of a sealant to reject incompressible objects from its surface is important to the functioning of a sealant.

12.3 *Apparatus*—Conduct this test using the standard penetrometer described in Test Method D 5, except replace the needle on this standard penetrometer with a ball penetration tool shown in Fig. 3 (total weight of the ball penetration tool and penetrometer spindle shall be 75 ± 0.01 g).

12.4 *Specimen Preparation*—Prepare one specimen as specified in Practice D 5167 using a 177.5-cm^3 (6-oz) tin can.

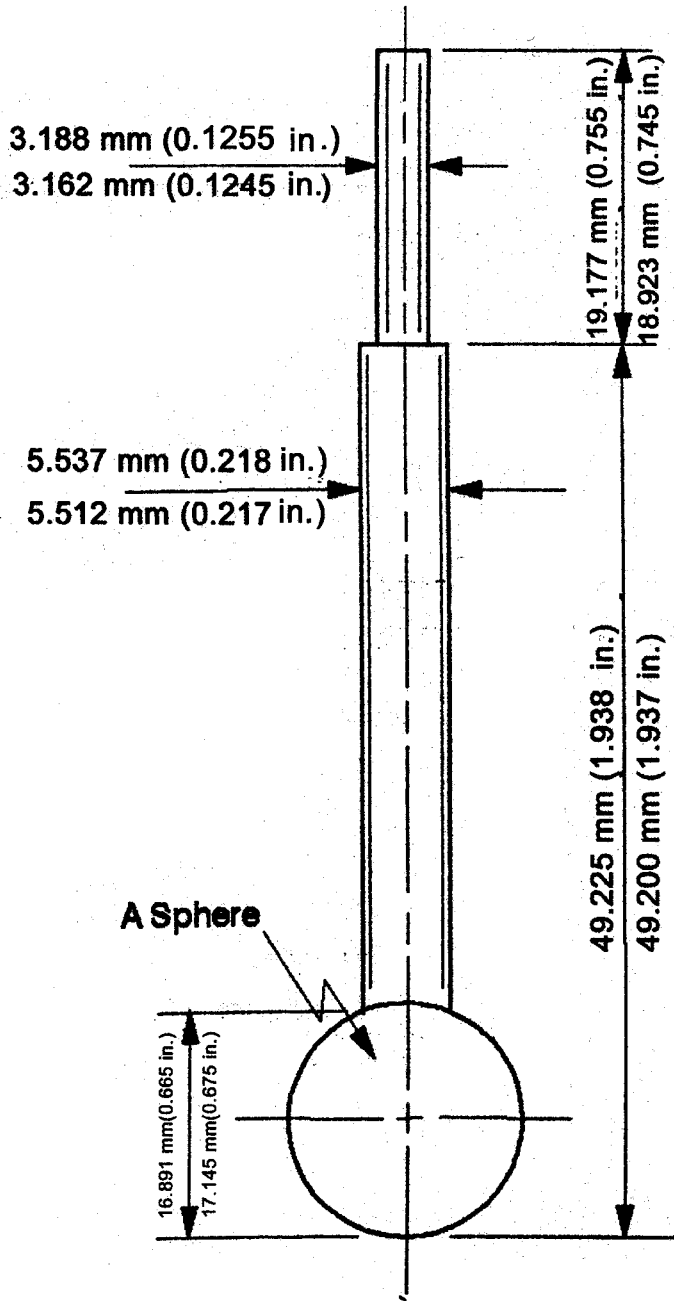

1. **Material: Steel**
2. **Weight of ball & shaft (shown): 27.5 ± 0.01 g**
3. **Total weight of ball, shaft & penetrometer shaft (not shown): 75 ± 0.01 g**
4. **Ball may be screw attached, brazed on or made with shaft.**
5. **Ball finish must be 63 RMS & diameter profile within 0.051 mm (0.002 in.)**

FIG. 3 Ball Penetration Tool

Cure the specimen at the temperature and for the time specified in the respective material specification under standard laboratory conditions prior to testing.

12.5 *Procedure*—Place the tin can specimen in a water bath maintained at $25 \pm 0.1^\circ\text{C}$ ($77 \pm 0.2^\circ\text{F}$) 2 h immediately before testing. Remove the specimen from the water bath, dry the surface and prepare the specimen for testing by coating the surface of the material lightly with talc and blowing off the excess. Do not test under water. Proceed as follows: Set the indicating dial to zero and place the ball penetration tool in contact with the surface of the specimen by using a light source so that initial contact of the ball and surface of the specimen

can be readily seen. Release the ball penetration tool, allow it to penetrate the specimen for 5 s, and record the reading as ball penetration, P . Without returning the dial pointer to zero, press the ball penetration tool down an additional 100 units (that is, to a reading of $P + 100$) at a uniform rate in 10 s. Reengage the clutch to hold the tool down for an additional 5 s, and during this time return the dial to zero. Release the clutch, allow the specimen to recover for 20 s, and record the final dial reading, F . (If the ball does not release freely from the specimen, disregard the resilience determination and re-talc surface of the specimen and test.) Make determinations at three points equally spaced from each other and not less than 13 mm ($\frac{1}{2}$ in.)

from the container rim. Compute the recovery (a measure of resilience) as follows:

$$\text{Recovery, \%} = P + 100 - F \quad (1)$$

12.6 *Report*—Record the average of three determinations obtained in 12.5 as the resilience.

12.7 *Precision and Bias*:

12.7.1 *Within Tin*—The single-operator deviation has been found to be 1.254. Therefore, the maximum difference between three values on the same sample should not differ by more than four units.

12.7.2 *Within and Between Laboratories*—Single-Operator Precision (resiliences 55 to 65). The single-operator standard deviation of a single test (test result is defined as the average of three resiliences) has been found to be 1.0894. Therefore, the results of two properly conducted tests by the same operator on the same material should not differ by more than three resilience units.

12.7.3 *Multilaboratory Precision*—(resilience 55 to 65). The multilaboratory standard deviation of a single test (test result is defined as the average of three resiliences) has been found to be 11.8132. Therefore, the results of two properly conducted tests in different laboratories should not differ by more than 33 resilience units.

13. Resilience, Oven Aged

13.1 *Scope*—This test method measures the materials ability to rebound a steel ball after being aged in an oven for seven days.

13.2 *Significance and Use*—The sealant is required to have an ability to reject incompressible objects after aging in order to maintain performance.

13.3 *Apparatus*, as described in 12.3.

13.4 *Specimen Preparation*—Same as described in 12.4.

13.5 *Procedure*—Oven-age the specimen in a forced-draft oven at the temperature and for the time specified in the respective material specification, then cool under standard conditions for 1 h and proceed as described in 12.5.

13.6 *Report*—Same as described in 12.6

13.7 *Precision and Bias*—The precision and bias of this test method for measuring oven aged resilience are as specified in Section 12.

14. Asphalt Compatibility

14.1 *Scope*—This test method covers sealant compatibility with an asphalt pavement.

14.2 *Significance and Use*—Asphalt incompatibilities can lead to oily exudates, which will lead to early failures on the road of the sealants covered in these test methods.

14.3 *Specimen Preparation* (see Note 2).

14.3.1 *Preparation of Asphalt Specimens*—Prepare two test specimens not less than 100 mm (4 in.) in diameter and 63 mm (2½ in.) in height of hot-mix asphaltic concrete using an AC-20 viscosity graded asphalt cement as described in Specification D 3381.

NOTE 2—Specimens prepared in accordance with the section on test specimens of Test Methods D 1074, or Practice D 1561 are suitable for this purpose. Specimens that are other than circular, but with similar dimensions and properties, are also acceptable. Density and asphalt

content of the specimens will be those values which would be specified in an asphaltic concrete pavement mix design using the design method specified by the purchasing agency.

14.3.2 *Grooving Asphalt Blocks*—Allow the test specimen to cool to room temperature, after which cut a groove 100 mm (4 in.) long by 13 ± 3.2 mm ($\frac{1}{2} \pm \frac{1}{8}$ in.) wide by 19 ± 3.2 mm ($\frac{3}{4} \pm \frac{1}{8}$ in.) deep in the top surface of each specimen by wet sawing with a power-driven masonry saw. Scrub the grooves thus formed with a stiff-bristle brush while holding specimens under running water to remove all residue from sawing. Allow the specimens to dry and return to room temperature, after which securely wrap them with cloth backed adhesive tape, or otherwise reinforce to prevent slumping or collapse during the ensuing test period. Caulk the ends of the grooves to prevent leaking. Pour joint sealant prepared as described in Practice D 5167 into the grooves, overfilling the grooves slightly. However, allow no joint sealant to overflow onto the surface of the asphaltic concrete adjacent to the grooves. After the sealing compound has cooled to room temperature, remove any overflow of sealing compound with a hot knife blade, so that the surface of the sealing compound is even with the surface of the specimens.

14.4 *Procedure*—Place the duplicate specimens in a forced-draft oven maintained at a temperature of $60 \pm 3^\circ\text{C}$ ($140 \pm 5^\circ\text{F}$) for 72 h.

14.5 *Interpretation of Results*—Immediately after removing from the oven and again after cooling to room temperature, examine the specimens for incompatibility (as required in the respective material specification) of the joint sealant with the asphaltic concrete. Report as required in the respective material specification.

14.6 *Precision and Bias*—No information is presented about precision or bias of this test method for bond evaluation since the results are nonquantitative.

15. Artificial Weathering

15.1 *Scope*—This test method describes a procedure for artificial weathering of sealants.

15.2 *Significance and Use*—A sealant must be able to withstand weathering to perform in its intended use. This test method is a laboratory evaluation of the resistance to weathering.

15.3 *Apparatus*:

15.3.1 *Artificial Weathering Apparatus*—Use carbon-arc type apparatus as specified in Practice G 153. The term cycle is defined as a total of the time intervals of light, followed by light and water spray.

15.4 *Specimen Preparation*—Prepare three specimens as follows: A treated (see Note 1) brass or TFE-fluorocarbon plastic mold 38 mm (1.5 in.) wide by 100 mm (4 in.) long by 6.4 mm (0.25 in.) deep shall be placed on a bright tin panel 76 mm (3 in.) wide by 152 mm (6 in.) long. Fill the mold with an excess of sealant, and allow the specimen to cure for a minimum of 1 h prior to trimming the specimen flush with the mold using a heated knife or spatula. Test in the equipment specified in 15.3.1.

15.5 *Test Procedure*—Test the three specimens in accordance with Method 1 of Practice G 23, except that the specimen spray water shall not exceed 20 ppm total solids.

Control black-panel temperature at $60 \pm 3^\circ\text{C}$ ($140 \pm 5^\circ\text{F}$) and test chamber relative humidity at $50 \pm 10\%$. Mount specimens as recommended to assume maximum uniformity of radiant exposure. The daily test cycle shall be as follows:

Test Condition	Exposure, min
light only	51
light and water spray	9
Total, per day	20 periods of 60 min

A complete test shall consist of 160 h exposure in the artificial weathering equipment specified in 15.3.

15.5.1 As an alternative to use of the carbon arc weatherometer for laboratory accelerated weathering (Practice G 153), the specimens can be exposed either in a fluorescent ultraviolet/condensation device or in a xenon arc weathering device that conform to requirements of Practices G 151 and G 154 or G 155, respectively. Operate the devices as described in Practice C 1442 using the UVA-340 lamp in the fluorescent device and daylight filters with the xenon arc.

15.5.2 The enclosed carbon arc exposure shall be used for referee purposes.

15.6 *Evaluation of Exposure*—Examine the test specimens in a cursory manner immediately upon the completion of each 20 h exposure period, while the specimens are approximately at test chamber temperature. Note any changes observed. Examine the specimens thoroughly on completion of the 160 h exposure, while the specimens are approximately at test chamber temperature.

15.7 *Precision and Bias*—No information is presented about precision or bias of this test method for weathering bond evaluation since the results are nonquantitative.

16. Tensile Adhesion

16.1 *Scope*—This is a test method to determine the elongation of a sealant before failure when adhered to concrete blocks.

16.2 *Significance and Use*—This test method gives a determination that the relative adhesive and cohesive strengths of a sealant are in proper balance.

16.3 *Apparatus*—Use a Tensile Adhesion Test Apparatus, capable of gripping the concrete blocks parallel to each other and pulling them apart at a separation rate of 12.7 ± 2.5 mm/min (0.5 ± 0.1 in./min) through a range of 0 to 200 mm (0 to 8 in.) minimum.⁵

16.4 *Specimen Preparation*—Prepare specimens as specified in 9.5 and cure as specified in the respective material specification.

16.5 *Procedure*—Place the test specimens in equipment as specified in 16.3 and pull apart at standard conditions and at a rate of 12.7 ± 2.5 mm/min (0.5 ± 0.1 in./min). Continue the extension until the specimen reaches complete cohesive or adhesive failure. Record and average the elongation of each of the three specimens, and note if the failure was cohesive or adhesive, and the percentage elongation of each.

16.6 *Report*—Report the results as required in the respective material specification.

16.7 *Precision and Bias*—The repeatability and reproducibility of this test method is being determined.

17. Solubility

17.1 *Scope*—This test method determines the solubility of a sealant by weight change after immersion in a reference fuel.

17.2 *Significance and Use*—Sealants for use in areas of possible fuel spill must be able to perform after being subjected to fuel spills.

17.3 *Specimen Preparation*—Prepare one test specimen as described in Practice D 5167. Weigh a 6 oz tin, record its tare weight and pour the specimen into this 6 oz tin as close to the top as possible.

17.4 *Test Procedure*—Weigh the specimen in the 6 oz tin to the nearest 0.01 g, subtract the 6 oz tin's weight and record the result as the initial weight, *IW*. Immerse the specimen for 24 h in at least 500 mL (0.53 qt) to provide at least 12 mm cover of clean test fuel conforming to the requirements for Reference Fuel B of Test Method D 471, maintained in a water bath at a constant temperature of $49 \pm 1^\circ\text{C}$ ($120 \pm 2^\circ\text{F}$). Use clean test fuel for each test. After the 24-h immersion, dry the specimen under the draft of a 300-mm (12-in.) diameter electric fan at standard conditions for 1 h. The placement of the fan and specimen shall be such as to maintain an air velocity of 150 to 0.76 to 2.54 m/s (500 ft/min) over the specimen. Weigh the specimen after drying, subtract the 6 oz tin's weight and record as final weight, *FW*. Calculate change in weight as follows:

$$\% \text{ Change in weight} = (IW - FW)/IW \times 100 \quad (2)$$

17.5 *Report*—Record the % change in weight.

17.6 *Precision and Bias*—The repeatability and reproducibility of this test method is being determined.

18. Flexibility

18.1 *Scope*—This test measures the ability of a sealant to be bent around a mandrel after being exposed to heat aging.

18.2 *Significance and Use*—Some materials can harden upon heat aging and become brittle which will affect the field performance.

18.3 *Specimen Preparation*—Prepare one specimen as specified in 8.4.

18.4 *Procedure*—Place the specimen in a forced-draft oven maintained at a temperature of $70 \pm 1^\circ\text{C}$ ($158 \pm 2^\circ\text{F}$) for 72 h. After removal from the oven, maintain at standard conditions for 24 h, and then slowly bend the tin plate with the sample intact over a 6.4 mm (0.25 in.) diameter mandrel producing a 90° bend in the plate with a maximum radius at the bend of 3.2 mm (0.125 in.). Locate the bend so that it is approximately midpoint in the 60 mm (2.36 in.) dimension of the specimen.

18.5 *Report*—Report the results as required in the respective material specification.

18.6 *Precision and Bias*—No information is presented about precision or bias of this test method for flexibility evaluation since the results are nonquantitative.

19. Keywords

19.1 fillers; formed in place; hot-applied; sealants

⁵ The Dillon Low Range Multi-Scale Universal Tester, Model M-1, from W. C. Dillon Co., Van Nuys, CA, has been found suitable.

ASTM International takes no position respecting the validity of any patent rights asserted in connection with any item mentioned in this standard. Users of this standard are expressly advised that determination of the validity of any such patent rights, and the risk of infringement of such rights, are entirely their own responsibility.

This standard is subject to revision at any time by the responsible technical committee and must be reviewed every five years and if not revised, either reapproved or withdrawn. Your comments are invited either for revision of this standard or for additional standards and should be addressed to ASTM International Headquarters. Your comments will receive careful consideration at a meeting of the responsible technical committee, which you may attend. If you feel that your comments have not received a fair hearing you should make your views known to the ASTM Committee on Standards, at the address shown below.

This standard is copyrighted by ASTM International, 100 Barr Harbor Drive, PO Box C700, West Conshohocken, PA 19428-2959, United States. Individual reprints (single or multiple copies) of this standard may be obtained by contacting ASTM at the above address or at 610-832-9585 (phone), 610-832-9555 (fax), or service@astm.org (e-mail); or through the ASTM website (www.astm.org).