



Standard Practice for In-Situ Measurement of Heat Flux and Temperature on Building Envelope Components¹

This standard is issued under the fixed designation C 1046; the number immediately following the designation indicates the year of original adoption or, in the case of revision, the year of last revision. A number in parentheses indicates the year of last reapproval. A superscript epsilon (ϵ) indicates an editorial change since the last revision or reapproval.

1. Scope

1.1 This practice covers a technique for using heat flux transducers (HFTs) and temperature transducers (TTs) in measurements of the in-situ dynamic or steady-state thermal behavior of opaque components of building envelopes. The applications for such data include determination of thermal resistances or of thermal time constants. However, such uses are beyond the scope of this practice (for information on determining thermal resistances, see Practice C 1155).

1.2 Use infrared thermography with this technique to locate appropriate sites for HFTs and TTs (hereafter called sensors), unless subsurface conditions are known.

1.3 The values stated in SI units are to be regarded as the standard. The values given in parentheses are for information only.

1.4 *This standard does not purport to address all of the safety concerns, if any, associated with its use. It is the responsibility of the user of this standard to establish appropriate safety and health practices and determine the applicability of regulatory limitations prior to use.*

2. Referenced Documents

2.1 ASTM Standards:

C 168 Terminology Relating to Thermal Insulating Materials²

C 518 Test Method for Steady-State Heat Flux Measurements and Thermal Transmission Properties by Means of the Heat Flow Meter Apparatus²

C 1060 Practice for Thermographic Inspection of Insulation Installations in Envelope Cavities of Frame Buildings²

C 1130 Practice for Calibrating Thin Heat Flux Transducers²

C 1153 Practice for the Location of Wet Insulation in Roofing Systems Using Infrared Imaging²

C 1155 Practice for Determining Thermal Resistance of Building Envelope Components from In-Situ Data²

3. Terminology

3.1 *Definitions*—For definition of terms relating to thermal insulating materials, see Terminology C 168.

3.2 Definitions of Terms Specific to This Standard:

3.2.1 *building envelope component*—a portion of the building envelope, such as a wall, roof, floor, window, or door, that has consistent construction.

3.2.1.1 *Discussion*—For example, an exterior stud wall would be a building envelope component, whereas a layer thereof would not be.

3.2.2 *thermal time constant*—the time necessary for a step change in temperature on one side of an item (for example, an HFT or building component) to cause the corresponding change in heat flux on the other side to reach 63.2 % of its new equilibrium value where one-dimensional heat flow occurs. It is a function of the thickness, placement, and thermal diffusivity (see Appendix X1) of each constituent layer of the item.³

3.3 Symbols Applied to the Terms Used in This Standard:

E = measured voltage from the HFT, typically in mV,

q = heat flux, W/m^2 (Btu/h-ft²),

S = heat-flux transducer conversion factor that relates the output of the HFT, E , to q through the HFT for the conditions of the test, $W/m^2 \cdot V$ (Btu/h-ft²·mV). This may be a function of temperature, heat flux, and other factors in the environment as discussed in Section 7. This may also be expressed as $S(T)$ to connote a function of temperature,

T = temperature, K (°C, °R, or °F),

t = time, s (hours, days), and

τ = thermal time constant, s (hours, days).

4. Summary of Practice

4.1 Heat flux transducers are installed on or within a building envelope component in conjunction with temperature transducers, as required. Heat flux through a surface is influenced by temperature gradients, thermal conductance, heat capacity, density and geometry of the test section, and by convective and radiative coefficients. The resultant heat fluxes

¹ This practice is under the jurisdiction of ASTM Committee C16 on Thermal Insulation and is the direct responsibility of Subcommittee C16.30 on Thermal Measurement.

Current edition approved Sept. 10, 1995. Published October 1995. Originally published as C 1046 – 85. Last previous edition C 1046 – 91.

² *Annual Book of ASTM Standards*, Vol 04.06.

³ $t = \tau$ when $q(t) = q_1 + (q_2 - q_1)(1 - e^{-t/\tau})$, where q_1 is the previous equilibrium heat flux, and q_2 is the new heat flux after the step change.

are determined by multiplying a conversion factor S of the HFT by its electrical output. The S values shall have been obtained according to Practice C 1130.

5. Significance and Use

5.1 Traditionally, HFTs have been incorporated into laboratory testing devices, such as the heat flow meter apparatus (Test Method C 518), that employ controlled temperatures and heat flow paths to effect a thermal measurement. The application of heat flux transducers and temperature transducers to building components in situ can produce quantitative information about building thermal performance that reflects the existing properties of the building under actual thermal conditions. The literature contains a sample of reports on how these measurements have been used **(1-8)**.⁴

5.2 The major advantage of this practice is the potential simplicity and ease of application of the sensors. To avoid spurious information, users of HFTs shall: (1) employ an appropriate S , (2) mask the sensors properly, (3) accommodate the time constants of the sensors and the building components, and (4) account for possible distortions of any heat flow paths attributable to the nature of the building construction or the location, size, and thermal resistance of the transducers.

5.3 The user of HFTs and TTs for measurements on buildings shall understand principles of heat flux in building components and have competence to accommodate the following:

5.3.1 Choose sensor sites using building plans, specifications and thermography to determine that the measurement represents the required conditions.

5.3.2 A single HFT site is not representative of a building component. The measurement at an HFT site represents the conditions at the sensing location of the HFT. Use thermography appropriately to identify average and extreme conditions and large surface areas for integration. Use multiple sensor sites to assess overall performance of a building component.

5.3.3 A given HFT calibration is not applicable for all measurements. The HFT disturbs heat flow at the measurement site in a manner unique to the surrounding materials **(9, 10)**; this affects the conversion constant, S , to be used. The user shall take into account the conditions of measurement as outlined in 7.1.1. In extreme cases, the sensor is the most significant thermal feature at the location where it has been placed, for example, on a sheet metal component. In such a case, meaningful measurements are difficult to achieve. The user shall confirm the conversion factor, S , prior to use of the HFT to avoid calibration errors. See Section 7.

5.3.4 The user shall be prepared to accommodate non-steady-state thermal conditions in employing the measurement technique described in this practice. This requires obtaining data over long periods, perhaps several days, depending on the type of building component and on temperature changes.

5.3.5 Heat flux has a component parallel to the plane of the HFT. The user shall be able to minimize or accommodate this factor.

6. Apparatus

6.1 Essential equipment for measuring heat flux and temperature includes the following:

6.1.1 *Heat Flux Transducer*—A rigid or flexible device (see Appendix X2) in a durable housing, composed of a thermopile (or equivalent) for sensing the temperature difference across a thin thermal resistive layer, which produces a voltage output that is a function of the corresponding heat flux and the geometry and material properties of the HFT.

NOTE 1—All calibrations relating output voltage to heat flux shall conform to Practice C 1130 and pertain to the measurement at hand. Manufacturers' calibrations supplied with HFTs often do not conform with Practice C 1130. Obtain the HFT conversion factor as described in Section 8 of Practice C 1130.

6.1.2 *Temperature Transducer*—A thermocouple, resistance thermal device (RTD), or thermistor for measuring temperatures on or within the construction, or for measuring air temperatures. Some HFTs incorporate thermocouples.

6.1.3 *Recorder*—An instrument that reads sensor output voltage and records either the voltage, heat flux, or temperature values calculated from appropriate formulas, with durable output (for example, magnetic tape, magnetic disk, punch tape, printer, or plotter).

6.1.4 *Attachment Materials*—Pressure-sensitive tape, adhesive, or other means for holding heat flux and temperature transducers in place on the test surface or within the construction.

6.1.5 *Thermal Contact Materials*—Gel toothpaste, heat sink grease, petroleum jelly, or other means to improve thermal contact between an irregular surface and a smooth HFT.

6.1.6 *Absorptance and Emittance Control Supplies*—Coatings or sheet material to match the radiative absorptance and emittance of the sensor with that of the surrounding surfaces.

7. HFT Signal Conversion

7.1 The conversion factor (S) is a function of the HFT design and the thermal environment surrounding the HFT **(8, 9)**. A difference between thermal conductivities of the HFT and its surroundings causes it to act either as a partial blockade or conduit for heat flux. Radiative heat passes into the HFT at a different rate than it does into the surrounding surface, depending on the mismatch between the absorptivities of HFT and surface. The presence of air moving across an HFT can change the conductance of the air film at the HFT and cause the heat flux through the HFT to differ from that through the surrounding surface.

7.1.1 Determine S according to the procedure outlined in Practice C 1130, as appropriate to the conditions of use, that is, surface-mounted or embedded and surrounded by materials that will be present.

7.2 Confirm that the time constant of the HFT is much less than the time constant of the building component to be measured if the temperatures throughout the HFT and the construction will not be steady state. If the mass of an HFT of a certain area is less than one fiftieth of the mass of the same area of building component, then its time constant is small enough. If not, then estimate the thicknesses and thermal

⁴ The boldface numbers in parentheses refer to the list of references at the end of this practice.

diffusivities of the constituent layers of the HFT and the building component, using Appendix X1 or other recognized technique, to determine whether the time constant of the HFT is less than one fiftieth of that of the component's time constant.

8. Selection of Sensor Sites

8.1 The user shall choose a place in the construction for siting the HFTs where one-dimensional heat flow perpendicular to the exterior surfaces occurs, unless the user is prepared to deal with multidimensional heat flow in the analysis of the data.

NOTE 2—For example, a sensor site in the center of a fully insulated stud cavity represents heat flow perpendicular to the wall surface, whereas a location near a stud or blocking does not. A wall incorporating concrete masonry units has significant multidimensional heat flow through the concrete webs and possible air convection cells in the block cores.⁵ Similarly, an empty stud cavity has convection as a potential lateral heat flow mechanism and a masonry or stone wall has vertical heat conduction near the ground level. Air leakage can also be a source of multidimensional heat flow.

8.2 Do not place the HFTs where they contribute more than 1 % additional resistance to the construction subject to thermal measurement, unless the thermal properties of the HFTs are well known and the analysis technique is appropriate.

8.3 Do not place HFTs on surfaces with high lateral conductance, unless the S has been confirmed for the precise condition.

8.4 Install HFTs either on an indoor surface of the component if the construction is complete or within a building component when the component is being constructed and retrieval is not required. Infrared thermography is required when the internal configuration of the component is poorly known. Seek perpendicular flow, and avoid unforeseen thermal anomalies.

8.5 Use infrared thermography to determine the characteristics of candidate sensor sites on the building component when the internal configuration of the component is poorly known (see Practices C 1060 and C 1153).

NOTE 3—Close visual inspection of a stud wall can often reveal the locations of framing members when there are slight imperfections above nailheads, but thermography can reveal whether or not there is unexpected cross blocking, air leakage, or convection owing to missing, incorrectly applied, or shifted insulation.

NOTE 4—Thermographic instruments produce a two-dimensional image of a surface by measuring thermal radiation emanating from that surface. A temperature gradient on the surface is seen as a variation in contrast or in pseudocolor on a viewer screen. If the radiation gradients are caused by heat transfer variations in the wall because of thermal anomalies, these anomalies and their locations are made visible. Certain thermographic patterns can be recognized as framing, air leakage, or convection.

8.6 Determine whether to deploy sensors in a line or in some other arrangement, based on knowledge of the component's internal configuration. Note that a wall with suspected

internal convection requires, at a minimum, sensors at the top, bottom, and center of the suspected convective area.

9. Test Procedures

9.1 *Sensor Site Selection*—Select appropriate sensor sites according to Section 8. The HFT shall cover a region of uniform heat flux on the chosen site. If the HFT covers a region with significantly nonuniform heat flux, then demonstrate that the HFT correctly averages the input it receives.

9.2 *Permanent Sensor Installation:*

9.2.1 Sensors built into the construction offer more reliable results than sensors mounted on an exterior surface, because they are usually protected from radiant heat sources and convection, which may affect the sensor differently than the surrounding building material. The measurement is also likely to have less variance.

9.2.2 Tape or glue the HFTs to a smooth surface within the construction to ensure good thermal contact.

9.2.3 Position temperature transducers on and within the construction, as required, to obtain temperature gradients across its thickness. Place sensors at the exterior surfaces and at interfaces between materials within the construction. Install sensors at the exterior surfaces in one of the following two ways:

9.2.3.1 Surface mount temperature transducers with tape or adhesive. Cover surface-mounted sensors with an opaque coating of the same surface absorptance as the surrounding material.

NOTE 5—Be aware that some visually opaque materials are transparent in the infrared spectrum.

NOTE 6—Surface mounting results in a slightly lower temperature reading in cool ambient conditions and a slightly higher reading in warm ambient conditions than the surface temperature, since the protruding sensor is more affected by air film temperature.

9.2.3.2 Flush mount temperature transducers by burying them at the same depth that the sensor is thick. Use the same paint, or in the case of a natural finish, such as brick or wood, a powder of that finish material made into a paste and glued around the sensor. For most nonmetallic materials (see Ref (11) or (12)), the absorptance is in the range of 0.85 to 0.90.

9.2.4 Check the uniformity of surface absorptance with an infrared imager or single-point radiometer. Check the match of absorptance of the covered HFT with that of the surrounding area by comparing the image or radiometer output of each area after a stabilization time of at least 15 min.

NOTE 7—Infrared imagers and single-point radiometers sense the radiation leaving a surface; they provide a direct relationship of visual or numerical output to surface absorptance for a given temperature. An HFT that changes the thermal resistance of the envelope component or diverts heat flux significantly will not be representative of its surroundings. Be aware that infrared devices are spectral in nature, so that the comparison is made for specific wavelength bands in the infrared, not for the total spectrum.

9.3 *Temporary Sensor Installation:*

9.3.1 Where the interior of the building construction is inaccessible or the sensor shall be removed nondestructively, mount the HFT on an accessible indoor surface of the construction. Place a layer of material over the entire exposed surface of the HFT that matches the HFT surface absorptance

⁵ Experience indicates, however, that the face of a concrete masonry unit distributes heat flux sufficiently that HFT placement is insensitive to location on the block.

to that of the surrounding surface and creates a smooth transition for air flow.

NOTE 8—A layer of masking tape, or some other thin material, will both match the HFT absorptance with that of most nonmetallic finishes and provide a smooth transition for air flow. If the surface is metallic, refer to a table of absorptivities or emissivities (**11, 12**) for guidance concerning an appropriate material, such as aluminum foil (shiny or dull side out). Furthermore, measurements on metallic surfaces are more sensitive to whether or not S represents field conditions. To test the match of HFT surface absorptance to the surrounding surface, confirm that the sensors are invisible to an infrared imager of sufficient spatial resolution to view objects one fifth the size of the HFT.

9.3.2 On smooth, flat surfaces, apply masking tape around the perimeter of the HFT and press it onto the surface to ensure good contact on the entire interface.

9.3.3 On rough surfaces, apply the HFT in the same manner as 9.3.2, except also apply a heat conductive material, such as gel toothpaste or petroleum jelly, between the sensor and the surface in a thin layer. Note that air gaps greater than 0.5 mm (0.02 in.) can cause errors from 2 to 10 % because of convection (**13**).

9.3.4 As an alternative, place the HFT under a rectangular cover of gypsum wallboard or plywood with a recessed area in the center for the HFT and provision for the wires to exit from under the cover. Choose this method if rapid fluctuations in HFT output are undesirable for the measurement. Use a cover of material about 0.3 m² (1 ft²) for HFTs smaller than 0.1 m on a side. Note that the cover will both diminish the variations in heat flux swings and add thermal resistance to the building component.

9.3.5 Use HFTs with an integral temperature transducer (TT) or install a TT with the HFT. Mount TTs on the surface as described in 9.3.2.

9.3.6 Connect HFT and TTs for each location to the recorder.

9.4 Data Acquisition and Analysis:

9.4.1 Establish the frequency of reading heat fluxes and temperatures required (for measuring thermal resistances, see Practice C 1155). Monitor the fluctuations in temperature and heat flux to confirm that they are consistent with expectations. Adjust the frequency of readings, if required.

9.4.2 Establish the frequency for recording heat fluxes and temperatures with a data acquisition system or an integrating voltmeter appropriate for the required calculation or graphic representation. Average the data obtained between recording intervals with an electronic averaging function or, in the case of discrete readings, using an appropriate, recognized method.

9.5 Duration of Measurement:

9.5.1 For determining the thermal resistance of building envelope components, follow the guidance given in Practice C 1155.

9.5.2 For other measurements, obtain the required number of temperature and heat flux readings.

NOTE 9—The thermal time constant of a component, the presence of insulation, and the variation and average value of the temperature difference (ΔT) across a component all influence how long it takes to have a change in temperature at one location in the section affect heat flow elsewhere. In most cases ΔT is an important variable. Refer to the literature (**1-8**).

10. Calculation

10.1 *Calculation of Heat Flux*—Calculate heat flux, q , according to the following equation, the time average of the HFT output:

$$q = S(T_i) \cdot E_i \quad (1)$$

where:

E_i = the averaged voltage reading, of the i th measurement, and

T_i = the corresponding temperature of the i th measurement.

NOTE 10— S can also be a function of other thermal factors. See Section 7.

10.2 *Calculation of Temperature*—Calculate temperature for each averaged temperature transducer output according to the calibration values or formulas for the sensor.

11. Interpretation of Results

11.1 *Corroboration of Results*—Assess the efficacy of measurements with reference to independent forms of information, such as as-built drawings or thermograms. If the results appear contrary to expectations, inspect the interior of the component, as required.

11.2 *Generalization of Results*—Consider the possible causes of sensor output variation before assessing results from any single sensor or the average of a group of them. If required, use thermography of the greater region surrounding the sensor site and random sampling of measurements at similar locations to interpolate conditions that are within the bounds of those measured and observed on the component. Note that interpolated values away from sensor sites are less accurate than measurements obtained at sensor sites.

11.3 *Multidimensional Heat Flow*—Analysis of HFT data shall include assessment of possible sources of significant multidimensional heat flow, such as lateral conduction or convection within the construction or thermal bridges through the region of measurement. See Appendix X3.

12. Report

12.1 Report the following information, using SI or inch-pound units:

12.2 A general description of the relevant parts of the building, including:

12.2.1 Dimensions,

12.2.2 Construction of walls and roofs,

12.2.3 A site plan and photographs of elevations,

12.2.4 Type of occupancy during measurement, and

12.2.5 Type of HVAC equipment and operating schedule.

12.3 The purpose of the measurement (for example, to provide data for Practice C 1155).

12.4 The criteria for choosing sensor sites to satisfy the goals of the measurement. Document the locations with scale drawings depicting the exact locations of each sensor and, where possible, photographs showing the appearance of the instrumentation. Include drawings of the construction monitored, if available.

12.5 A statement describing how Practice C 1130 was used to determine S for the heat flux transducers and its appropriateness for the conditions of the test.

12.6 An explanation of efforts to make all sensors thermally similar to their surroundings. State absorptivities of materials found and those used for masking.

12.7 Provide a report of heat flux and the temperatures measured for each sensor site as a function of time, averaged for each block of time.

12.8 An assessment of whether the data obtained are sufficient for a conclusion that satisfies the goal of the test. If the building component allows convective heat transfer at sensor locations, explain how the procedure represented this condition.

12.9 A report on ambient weather conditions during the test, including temperature, insolation, precipitation, and wind.

12.10 A list of frequency of measurement, frequency of recording, and duration of test.

12.11 An estimate of the precision and bias of the measurement.

13. Precision and Bias

13.1 The repeatability of the results of using HFTs depends on obtaining data frequently, relative to the speed of the phenomenon to be observed. HFTs render a rapidly varying output signal, especially when exposed to convection. The accuracy of HFTs depends on ensuring that the calibration

corresponds to the conditions of the measurement, both in materials surrounding the sensor and in prevailing thermal conditions.

13.2 The repeatability of a thermal test employing HFTs and TTs can result in a standard deviation of less than 10 %, considering only the error contribution of the instrumentation. Multiple replicates of sensor calibrations can provide an estimate of the standard error of the sensor. Sensors installed side-by-side on a building envelope can provide an estimate of the standard error of the measurement technique. A synopsis of a propagation-of-errors analysis is provided in Appendix X4. The thermal behavior of the construction may change significantly because of internal convection, air leakage, or moisture content and may make certain measurements more difficult to duplicate.

13.3 The bias of HFTs used in the field is difficult to demonstrate. Adherence to this procedure will minimize bias. In fully insulated frame construction, a small (10 %) discrepancy between thermal resistance estimated by in-situ measurement and theoretical thermal resistance has been obtained repeatedly where the construction type has been verified independently (**14, 15, 16, 17**).

14. Keywords

14.1 heat flow; heat flow sensor; heat flux transducer; HFT; in situ; measurement; resistance thermal device; RTD; temperature; temperature sensor; temperature transducer; thermistor; thermocouple

APPENDIXES

(Nonmandatory Information)

X1. ESTIMATING THERMAL TIME CONSTANTS

X1.1 The following method (**18**) for estimating the thermal time constant of a component adjusts the thickness of each layer within it, as if each were made of the same material as an arbitrarily chosen layer. For a more exact method, see Schimmel, et al. (**19**).

$$\tau = \frac{a_k}{\pi^2} \left(\sum_{n=1}^N g_n \cdot x_n \right) \quad (\text{X1.1})$$

where:

- a_n = $r_n \cdot C_n \cdot d_n$, the reciprocal of diffusivity of a layer, n ,
- r_n = thermal resistivity of a layer, n ,
- C_n = specific heat of a layer, n ,
- d_n = density of a layer, n ,
- x_n = thickness of a layer, n ,
- g_n = $(a_n/a_k)^{1/2}$ conversion constant adjusting the thickness of a layer to make the material uniform throughout the component,
- k = subscript of the arbitrary layer chosen for normalizing, and

n = subscript for layers.

X1.2 In using Eq X1.1, take care to use consistent units. For example, SI properties often have seconds in the units. If one seeks the time constant in hours, the result must be divided by 3600.

X1.3 Thermal time constants for some examples of construction are:

Component	Thermal Time Constant, h
Wood frame wall—2 by 4	1.0
Wood frame wall—2 by 6	1.3
Insulated masonry block wall	3.4
Built-up roof on metal deck	0.3
Protected membrane roof on concrete slab	112

NOTE X1.1—These examples pertain only to the specific assumptions made about thickness, density, thermal resistivity, and specific heat.

X2. HFT DESCRIPTION

X2.1 A typical HFT may incorporate a central sensing region, a guard region around the sensing region, and a case. To obtain sensitivity, the sensing region employs multiple thermocouple junctions on opposite sides of a core material. The thermocouples give a voltage output that can be related to the temperature drop across the sensing region, and this temperature difference is a function of the heat flow through the HFT. The guard region helps ensure that heat flow at the sensing region is perpendicular to the face of the HFT. The case protects the components of the sensor.

X2.2 HFT construction may employ (1) a wire wrapped around a core material, or (2) printed circuits with a uniform array of thermocouple junctions. The two constructions vary in their thermal homogeneity:

X2.2.1 In the first kind of construction, the wire is plated to create thermocouple junctions in series on opposite sides of the

core material. The wire may be wound around (1) a flat, thin core (Fig. X2.1), or (2) around a long strip, standing on edge (Fig. X2.2). In the first case, the windings in the HFT illustrated in Fig. X2.1 penetrate the thickness of the core symmetrically away from the line of thermocouple junctions in the center and may permit perpendicular flow along that centerline. In the second case, the long strip may itself be coiled to form a sensing region. Unless the guard region also incorporates such a strip with an equal density of windings, it may not achieve perpendicular heat flow in the sensing region.

X2.2.2 In the second approach, otherwise called “parallel isothermal planes” or “integrated area” (Fig. X2.3), the HFT is thermally uniform throughout both the central sensing region and the guard region, because of the integrated circuit construction. Independent readings may be obtained from different regions of such an HFT.

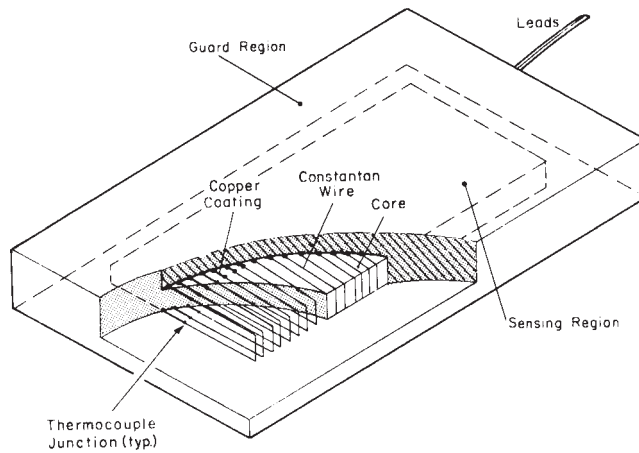
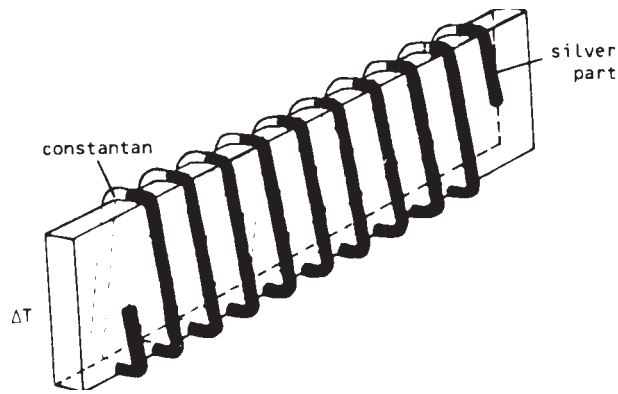
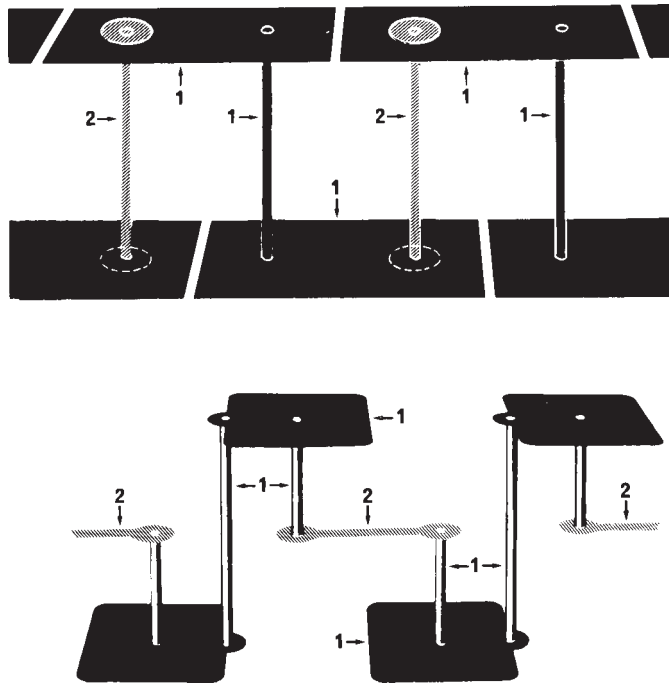

FIG. X2.1 Example of HFT Construction (Described in Case 1a in Appendix X2)



NOTE 1—Reproduced from Degenne and Klarsfeld “A New Type of Heat Flowmeter for Application and Study of Insulation and Systems,” ASTM-STP 885, 1985, p. 165.

FIG. X2.2 Example of HFT Construction (Described in Case 1b in Appendix X2)



NOTE 1—These different approaches are based on integrated circuit construction and can be made uniform in both the sensing and guard regions.

NOTE 2—Reproduced from Degenne and Klarsfeld “A New Type of Heat Flowmeter for Application and Study of Insulation and Systems,” ASTM-STP 885, 1985, 166, 168.

FIG. X2.3 Example Details of Parallel Isothermal Planes Construction for HFTs, 1 = copper, 2 = nickel or Constantan

X3. HEAT FLUX TRANSDUCER PLACEMENT RECOMMENDATIONS

X3.1 The recommendations in the following paragraphs represent a partial summary of techniques that have been tried.

X3.1.1 Some construction has only minimal lateral heat flow paths. However, most construction has significant lateral heat flow paths. In the laboratory such paths are purposely avoided. In the field they are difficult to avoid. The list of lateral heat flow problems includes: thermal bridges from structural members or fasteners, internal convection paths, and

air leakage paths. These comments pertain especially where the size of the HFT is significantly smaller than the scale of the thermal patterns on the construction.

X3.2 *Thermal Bridges from Framing*—If the intent of the measurement is to represent the most favorable contribution of the insulation between framing members, then a line of HFTs midway between framing members and parallel to them is

recommended. If the purpose is to characterize the distribution of heat flow on a line that crosses framing members at right angles, then a line of HFTs that are small compared to the distance between framing members should be placed from the center of a framing member to the center of the space between members. Such a placement should be repeated several times.

X3.3 Thermal Bridges from Fasteners—Thermography should permit detection of this type of anomaly. As long as the surface layers are not especially conductive, placement of HFTs away from fasteners should prevent an unrepresentative reading. Placement of a small HFT over a fastener can help represent the contribution of fasteners to heat transfer.

X3.4 Thermal Bridges in Concrete or Masonry Construction—Masonry and concrete are comparatively conductive in relation to other building materials, except for metals. Therefore, a significant potential for lateral heat flow exists where insulation and concrete or masonry coexist. For example, a masonry wall with exterior insulation may conduct much heat laterally via a concrete slab roof or the concrete foundation in preference to heat flow directly through the insulation.⁵

X3.5 Thermal Bridges Within Concrete Masonry Units—Concrete masonry units (CMUs) often are not solid; instead CMU faces are connected by concrete webs that are separated by air spaces. If the CMUs contribute a major part of the overall resistance, the variation in heat flux along the block face will be greater than if the CMUs contribute a minor amount to the overall resistance. CMUs with insulated cores

can have pronounced differences in surface temperature between surface areas adjacent to webs and those adjacent to cores.

X3.6 Lateral Heat Flow Paths—Lateral heat flow may occur because of air movement or thermal bridges. The use of instrumentation should recognize that the flux into one surface may be displaced from the corresponding flux out of another surface. For example, a Z-girt has flanges that are not directly across from each other that conduct heat from one surface to the other at displaced locations. Therefore, the HFTs may be positioned to correspond to the location of the flanges, if heat flow across the girt is of interest.

X3.7 Internal Convection:

X3.7.1 Internal convection is certain to occur in uninsulated construction that contains air spaces. It is also likely to occur through flaws created by bad workmanship in insulation or where air spaces purposely exist.

X3.7.2 In a vertical stud space with or without insulation, the following minimum precaution is advised: Place an HFT near the bottom and top of the stud space and one in the center. In cases where there is horizontal fire blocking at mid-height, this approach would be repeated for the top and bottom halves of the wall. Additional HFTs increase the completeness of information obtained.

X3.8 Air Leakage Paths—Air leakage will cause a spurious calculation of thermal resistance from thermal sensor data. Thermography can help identify air leakage sites where instrumentation would be inappropriate.

X4. PROPAGATION OF ERRORS

X4.1 Some of the factors affecting HFT measurement accuracy (together with a likely percentage standard deviation attributable to that factor) follow. They are explained and justified in (14).

X4.1.1 Thermal conductivities of HFT and its surroundings (3 %),

X4.1.2 Convection mode changing over sensor, causing a + 21 % bias (26 %),

X4.1.3 Mismatch of HFT absorptivity with surroundings (6 %), and

X4.1.4 Thermal contact of HFT with surface (1 %).

X4.2 A propagation-of-errors analysis indicates that the resulting standard deviation of an HFT measurement would be approximately 10 % of the mean of the measurements.

X4.3 Thermal resistance measurements of 19 buildings (17) demonstrated that the technique is repeatable; that is, the same data time series with different starting times results in the same thermal resistance. Side-by-side sensors give the same results (± 5 %), and different buildings of the same construction give similar results. Buildings whose construction was verified by boring into the wall gave measurements that were within 10 % agreement with ASHRAE calculations (16). Also,

convection cells were very evident, even in insulated frame walls, necessitating an array of sensors from the top to the bottom of the wall.

X4.4 Convection and surface conductivity mismatches have the most potential to affect the results. Heat flux can be represented through a surface attributable to convective, q_h , and radiational, q_r , sources as:

$$q_w = q_h + q_r \quad (X4.1)$$

and assume (for a wall in this case) that $q_h = (0.34) q_w$ and $q_r = (0.66) q_w$. Assume that heat flow through the HFT is different from that through the wall:

$$q_s = C_{sc} \cdot C_{tc} (C_{ct} q_h + C_{am} q_r) \quad (X4.2)$$

Surface conductivity: $C_{sc} = 1.0 \pm 0.03$

Thermal contact: $C_{tc} = 1.0 \pm 0.01$

Convection bias: $C_{ct} = 1.21 \pm 0.26$

Absorptivity match: $C_{am} = 1.0 \pm 0.06$

Eq X4.1 and X4.2 give the ratio between the HFT readings and the heat flow through its surroundings:

$$R_q = q_s/q_w = C_{sc} \cdot C_{tc} (0.34 C_{ct} + 0.66 C_{am}) \quad (X4.3)$$

X4.5 A propagation-of-errors analysis obtains the standard

deviation of the overall measurement as a function of each correction factor and its standard deviation:

$$S_{R_q}^2 = \left(\frac{\partial R_q}{\partial C_{sc}}\right)^2 S_{sc}^2 + \left(\frac{\partial R_q}{\partial C_{tc}}\right)^2 S_{tc}^2 + \left(\frac{\partial R_q}{\partial C_{ct}}\right)^2 S_{ct}^2 + \left(\frac{\partial R_q}{\partial C_{am}}\right)^2 S_{am}^2 \quad (X4.4)$$

For the values listed after Eq X4.2, $S_{R_q}/R_q = 9.6\%$ for the reasonably pessimistic assumptions we made.

X4.6 Of the error sources reviewed above, only convection has a potential for causing a systematic bias by changing

modes of flow; the others merely create a potential for scatter about the correct reading. Because convection represents at most 40 % of the heat flow from the room to the HFT or wall, its importance as an error source is diminished, especially when tape is used to fair the sensor smoothly onto the wall. The 10 % pessimistic assessment of error ascribable to using the HFT as a sensing instrument makes more elaborate precautions such as thermal guards or covers seem unnecessary in many instances.

REFERENCES

- (1) Brown, W. C., and Schuyler, G. D., "In Situ Measurements of Frame Wall Thermal Resistance," *ASHRAE Transactions HO-82-3, No. 2*, American Society of Heating, Refrigerating and Air Conditioning Engineers, Atlanta, GA, 1982.
- (2) Carroll, W. L., *Thermal Performance of Buildings and Building Envelope Systems: An Annotated Bibliography*, Lawrence Berkeley Laboratory, LBL 8925, Berkeley, CA, 1970.
- (3) Flanders, S. N., and Marshall, S. J., "Toward In-Situ Building R-value Measurement," *CRREL Report 84-1*, U.S. Army Corps of Engineers, Cold Regions Research and Engineering Laboratory, Hanover, NH, 1984.
- (4) Flanders, S. N., "Measuring Thermal Performance of Building Envelopes—Nine Case Studies," *CRREL Report 85-7*, U.S. Army Corps of Engineers, Cold Regions Research and Engineering Laboratory, Hanover, NH, 1985.
- (5) Kuehn, T. H., "Experimental Temperature and Heat-Flow Measurements from an Insulated Concrete Bermed Wall and an Adjacent Floor," *ERIO-81072*, Iowa State University, Preprint, Ames, IA, 1980.
- (6) Kuehn, T. H., "Field Heat-Transfer Measurements and Life-Cycle Cost Analysis of Four Wood-Frame Wall Constructions," *ASHRAE Transactions HO-82-3, No. 1*, American Society of Heating, Refrigerating, and Air Conditioning Engineers, Atlanta, GA, 1983.
- (7) Treado, S. J., "Thermal Resistance Measurements of a Built-Up Roof System," *NBSIR 80-2100*, National Bureau of Standards, Washington, DC, 1980.
- (8) Flanders, Stephen N., ed., "In-Situ Heat Flux Measurements in Buildings," *CRREL Special Report 91-3*, U.S. Army Corps of Engineers, Cold Regions Research and Engineering Laboratory, Hanover, NH, 1991.
- (9) Trethowen, H. A., "Systematic Errors with Surface-Mounted Heat Flux Transducers and How to Live With Them," *In-Situ Heat Flux Measurements in Buildings—Applications and Interpretations of Results*, *CRREL Special Report 91-3*, U.S. Army Corps of Engineers, Cold Regions Research and Engineering Laboratory, Hanover, NH, 1991, pp. 15–27.
- (10) Schwerdtfeger, P. ed., "The Measurement of Heat Flow in the Ground and the Theory of Heat Flux Meters," *CRREL Technical Report 232*, U.S. Army Corps of Engineers, Cold Regions Research and Engineering Laboratory, Hanover, NH, 1979.
- (11) Madding, R., *Thermographic Instruments and Systems*, University of Wisconsin-Extension, Madison, WI, 1979.
- (12) *ASHRAE Handbook of Fundamentals*, American Society of Heating, Refrigerating and Air Conditioning Engineers, Atlanta, GA, 1982.
- (13) Johansson, G., "Heat-Flow Measurements, Thermoelectrical Meters, Function Principles and Sources of Error," *Report TVH-3003*, Lund Institute of Technology, Lund, Sweden, 1979. (Draft translation, March, 1982, U.S. Army Corps of Engineers, Cold Regions Research and Engineering Laboratory, Hanover, NH.)
- (14) Flanders, S. N., "Heat Flow Sensors on Walls—What Can We Learn?," *Building Applications of Heat Flux Transducers, STP 885*, E. Bales, M. Bomberg, and G. E. Courville, Eds., American Society for Testing and Materials, 1985, pp. 140–159.
- (15) Courville, G. E., Desjarlais, A. O., Tye, R. P., and McIntyre, C. R., "A Comparison of Two Independent Techniques for the Determination of In-Situ Thermal Performance," *Insulation Materials, Testing, and Applications ASTM STP 1030*, D. L. McElroy and J. F. Kimpflen, eds., American Society for Testing and Materials, 1990, pp. 496–509.
- (16) Flanders, S. N., "Measured Insulation Improvement Potential for Ten U.S. Army Buildings," *Thermal Insulation Materials and Systems ASTM STP 922*, F. J. Powell and S. L. Matthews, eds., American Society for Testing and Materials, 1987, pp. 202–220.
- (17) Flanders, S. N., "Measured and Expected R-Values of 19 Building Envelopes," *ASHRAE Transactions*, American Society of Heating, Refrigerating and Air Conditioning Engineers, Atlanta, GA, Volume 91, Part 2, 1985.
- (18) Flanders, S. N., "Time Constraints on Measuring Building R-Values," *CRREL Report 80-15*, U.S. Army Corps of Engineers, Cold Regions Research and Engineering Laboratory, Hanover, NH, 1980.
- (19) Schimmel, W. P., Beck, J. V., Donaldson, A. B., "Effective Thermal Diffusivity for a Multimaterial Composite Laminate," *Journal of Heat Transfer*, Transactions of the American Society of Mechanical Engineers, Volume 99, Number 3, August 1977.

ASTM International takes no position respecting the validity of any patent rights asserted in connection with any item mentioned in this standard. Users of this standard are expressly advised that determination of the validity of any such patent rights, and the risk of infringement of such rights, are entirely their own responsibility.

This standard is subject to revision at any time by the responsible technical committee and must be reviewed every five years and if not revised, either reapproved or withdrawn. Your comments are invited either for revision of this standard or for additional standards and should be addressed to ASTM International Headquarters. Your comments will receive careful consideration at a meeting of the responsible technical committee, which you may attend. If you feel that your comments have not received a fair hearing you should make your views known to the ASTM Committee on Standards, at the address shown below.

This standard is copyrighted by ASTM International, 100 Barr Harbor Drive, PO Box C700, West Conshohocken, PA 19428-2959, United States. Individual reprints (single or multiple copies) of this standard may be obtained by contacting ASTM at the above address or at 610-832-9585 (phone), 610-832-9555 (fax), or service@astm.org (e-mail); or through the ASTM website (www.astm.org).