



Designation: E 1556 – 9803

An American National Standard

Standard Specification for Epoxy Resin System for Composite Skin, Honeycomb Sandwich Panel Repair¹

This standard is issued under the fixed designation E 1556; the number immediately following the designation indicates the year of original adoption or, in the case of revision, the year of last revision. A number in parentheses indicates the year of last reapproval. A superscript epsilon (ϵ) indicates an editorial change since the last revision or reapproval.

1. Scope

1.1 This specification covers the requirements for an epoxy resin system intended for the repair of sandwich panels for durable, rigidwall, relocatable structures. It must be usable in a field environment and shall not require the use of special equipment such as autoclaves or presses. The epoxy system covered by this specification shall be usable for simultaneous impregnation of a wet-layup composite skin and bonding of that skin to a substrate honeycomb core. The material shall withstand exposure to temperatures from -54 to 93°C (-65 to 199°F) and high relative humidity, and also the combination of stress, temperature, and relative humidity that are expected to be encountered in service.

1.2 The values stated in SI units are to be regarded as standard where only SI units are given or where SI units are given first followed by inch-pound units; where inch-pound units are given first followed by SI units, the inch-pound units are to be regarded as the standard.

1.3 The following safety hazards caveat refers only to the test methods described in this specification. *This standard does not purport to address all of the safety concerns, if any, associated with its use. It is the responsibility of the user of this standard to establish appropriate safety and health practices and determine the applicability of regulatory limitations prior to use.*

2. Referenced Documents

2.1 ASTM Standards:

¹ This specification is under the jurisdiction of ASTM Committee E-6 E06 on Performance of Buildings and is the direct responsibility of Subcommittee E06.53 on Materials and Processes for Durable Rigidwall Relocatable Structures.

Current edition approved April 10, 1998; Oct. 1, 2003. Published August 1998; October 2003. Originally published as E 1556-93; approved in 1993. Last previous edition approved in 1998 as E 1556 – 93a8.

- ~~C 297 Test Method for Tension Flatwise Tensile Strength of Flat Sandwich Constructions in Flatwise Plane² Constructions~~
- D 792 Test Methods for Density and Specific Gravity (Relative Density) of Plastics by Displacement
- ~~D 2344 Test Method for Apparent Interlaminar Shear Strength of Parallel Fiber Composites Polymer Matrix Composite Materials by Short-Beam Method~~
- D 2584 Test Method for Ignition Loss of Cured Reinforced Resins
- D 2734 Test Methods for Void Content of Reinforced Plastics
- D 3165 Test Method for Strength Properties of Adhesives in Shear by Tension Loading of Single-Lap-Joint Laminated Assemblies
- E 874 Practice for Adhesive Bonding of Aluminum Facings to Nonmetallic Honeycomb Core for Shelter Panels
- E 1091 Specification for Nonmetallic Honeycomb Core for Use in Shelter Panels

2.2 Federal Specifications:

~~PPP-B-566 Box, Folding, Paperboard³~~

~~PPP-B-636 Box, Shipping, Fiberboard⁷~~

~~PPP-B-676 Boxes, Set Up⁷~~

2.3 Federal Standard:

~~Fed. Std. No. 102 Preservation, Packaging, and Packing Levels⁷~~

2.4 Military Specifications:

~~MIL-C-9084C Cloth, Glass, Finished for Epoxy Resin Laminate⁷~~

~~MIL-P-18177C Plastic Sheet,~~

~~MIL-I-24768 Insulation, Plastic, Laminated, Thermosetting, Glass-Fiber Base, Epoxy Resin² Glass-Cloth, Epoxy-Resin²~~

~~2.53 Military Standards:~~

~~MIL-STD-105 Sampling Procedures and Tables~~

~~MIL-STD-1916 DOD Preferred Methods for Inspection by Attributes²~~

~~MIL-STD-129 Marking Acceptance of Product²~~

~~2.4 Commercial Standards~~

~~SAE-AMS-C-9084 Cloth, Glass, Finished for Shipment and Storage² Epoxy Resin Laminates³~~

3. Physical Requirements

3.1 Working Characteristics:

3.1.1 *Application*— The components of the epoxy resin shall be readily hand-mixed to a smooth consistency suitable for application. It shall be uniform and free of lumps. The resin components, once mixed, shall not settle out. The epoxy material shall be suitable for the wet-layup impregnation of ~~MIL-C-9084C~~ SAE-AMS-C-9084 glass cloth and for application to core materials over the temperature range of 16 to 38°C (60 to 100°F) and at relative humidities of 30 to 75 %.

3.1.2 *Application Life*— The application life of a 200-g kit of the mixed epoxy system shall be at least 60 min when tested in accordance with 3.1.5. The epoxy shall be considered to have reached the end of its application life when the viscosity of this 200-g quantity of mixed adhesive exceeds 20 000 centipoise.

3.1.3 *Curing*—The epoxy system shall be capable of curing at 23 ± 2°C (73 ± 4°F) in 7 days, or for no longer than 3 h at a temperature of 60 to 66°C (140 to 151°F), with a curing pressure not to exceed 14 psig. In a 23 ± 3°C cure, the curing pressure is not required to be maintained after the first 24 h. In a 23 ± 2°C cure, the epoxy material shall develop the property levels listed in Table 1 within the first 24 h of cure (see 7.3.5). In order to meet the requirements of this specification, the property levels listed in Tables 2-4 must be achieved with the 7-day cure at 23 ± 2°C (73 ± 4°F).

3.1.4 *Storage Life*— The storage life period of the two parts of the epoxy resin system, when stored in airtight containers at 23°C (73°F), shall be at least 12 months from the date of shipment when tested in accordance with 7.3.5.

3.1.5 *Viscosity*—The viscosity of a 200-g kit of the mixed resin system shall be determined at 23 ± 2°C (73 ± 4°F) using a Brookfield viscometer with a No. 3 spindle at 20 rpm. A viscosity curve shall be determined by taking a reading immediately after mixing, and every 5 min thereafter until the viscosity exceeds 20 000 centipoise. The viscosity immediately after mixing shall not exceed 14 000 centipoise.

3.2 *Mechanical Properties*—Mechanical properties of test specimens prepared and tested as specified in Section 7 shall meet the respective requirements listed in Tables 2-4.

3.3 *Instruction Sheet*—The manufacturer shall provide a dated, coded, and titled instruction sheet outlining instructions for use of the epoxy system in impregnating and bonding ~~MIL-C-9084C~~ SAE-AMS-C-9084 glass composite skins to honeycomb cores (Specification E 1091, Types I or II). These instructions shall be supplied by the manufacturer with the test report when requesting qualification (see 6.3) and also with each shipment of epoxy material (see 9.2). The following information shall be included:

3.3.1 All of the information listed in 5.3.1-5.3.12~~1~~.

3.3.2 The application life of the mixed epoxy system at 23 ± 2°C (73 ± 4°F) and 38 ± 2°C (100 ± 4°F).

3.3.3 Mixing instructions shall be stated in detail for the epoxy resin system in the particular container supplied.

3.3.4 Application, impregnating, and curing instructions, including the spreading method, thickness range, and temperature/relative humidity working limitations.

3.3.5 Material Safety Data Sheets and necessary safety precautions to be observed throughout all operations.

3.3.6 Any other pertinent information relative to the use and storage of the two-part system (resin and curing agent) package (see 9.2).

4. Significance and Use

4.1 Epoxy resin systems used in the repair of composite skin sandwich panels for durable, rigidwall, relocatable shelters must have a combination of mechanical property levels and environmental resistance that will assure long-term durability of the skins

Annual Book of ASTM Standards, Vol 15.03:

² Available from Standardization Documents Order Desk, Bldg. 4 Section D, 700 Robbins Ave., Philadelphia, PA 19111-5094, Attn: NPODS.

Annual Book

³ Available from Society of ~~ASTM Standards, Vol 08.01:~~ Automotive Engineers (SAE), 400 Commonwealth Dr., Warrendale, PA 15096-0001.

TABLE 1 Property Requirements for 24-h, 23°C Cure

Property	Test Condition	Number of Specimens	Average Must Exceed		Minimum Must Exceed, ^A	
			MPa	(psi)	MPa	(psi)
Tensile Lap Shear Strength in accordance with 7.2.1, 7.3.1	23°C (73°F), dry	5	6.9	(1000)	5.85	(850)
Apparent Horizontal Shear Strength in accordance with 7.2.2, 7.3.2	23°C (73°F), dry	5	15.5	(2250)	13.15	(1910)

^A All specimens tested must exceed these minimum values.

TABLE 2 Tensile Lap Shear Strength Requirements (See 7.3.1)

Test Condition	Number of Specimens	Average Must Exceed		Minimum Must Exceed, ^A	
		MPa	(psi)	MPa	(psi)
-40°C (-40°F), dry	5	13.8	(2000)	11.7	(1700)
23°C (73°F), dry	5	13.8	(2000)	11.7	(1700)
93°C (200°F), wet ^B	5	6.9	(1000)	5.9	(850)

^A All specimens tested must exceed these minimum values.

^B Wet = tested immediately after 30 days' exposure to 60°C (140°F) and 95 to 100 % R.H.

TABLE 3 Apparent Horizontal Shear Strength Requirements

Test Condition	Number of Specimens	Average Must Exceed		Minimum Must Exceed, ^A	
		MPa	(psi)	MPa	(psi)
23°C (73°F), dry	5	31.0	(4500)	26.3	(3820)
93°C (200°F), wet ^B	5	13.8	(2000)	11.7	(1700)

^A All specimens tested must exceed these minimum values.

^B Wet = tested immediately after 30 days exposure to 60°C (140°F) and 95 to 100 % R.H.

TABLE 4 Flatwise Tensile Strength Requirements

Test Condition	Number of Specimens	Average Must Exceed		Minimum Must Exceed, ^A	
		MPa	(psi)	MPa	(psi)
-40°C (-40°F), dry	5	2.8	(406)	2.4	(345)
23°C (73°F), dry	5	2.8	(406)	2.4	(345)
80°C (176°F), wet ^B	5	1.38	(200)	1.17	(170)

^A All specimens tested must exceed these minimum values.

^B Wet = tested immediately after 30 days exposure to 60°C (140°F) and 95 to 100 % R.H.

and the skin-to-core adhesive bonds when exposed to severe climatic exposures. In addition, these epoxy materials must have processability characteristics that permit their use in a variety of repair scenarios and environments.

4.2 *Intended Use*—Epoxy systems conforming to this specification are intended for use in the repair of honeycomb panels at the maintenance field level. The material is intended for use with ~~MIL-C-9084C~~ SAE-AMS-C-9084 glass cloth.

4.2.1 This is a procurement control document for the procurement of the epoxy system and designers shall be aware that the test values specified herein are based upon tests performed with specific glass-resin composite adherends and shall not be used for design data.

4.2.2 Epoxy systems covered by this specification are not intended for use in production bonding of sandwich construction.

5. Material and Ordering Information

5.1 *General Description*—The material shall be a two-part thermosetting epoxy system containing no asbestos, which shall not have a deleterious effect on the components being impregnated and bonded. It shall have physical characteristics that meet the requirements of Sections 3 and 6.

5.1.1 *Formulation Changes*—The epoxy material shall be approved only for the formulation that has passed the qualification tests and shall be used by the fabricator as approved. Any changes by the manufacturer, such as the adding or changing of pigments, hardeners, or fillers, or changes in the type or method of manufacture, changes in formulation of the basic resin, or any other changes, shall be cause for designating the adhesive as a new product that shall not be considered approved. The changed epoxy resin system shall be given a new code number and shall be resubmitted for approval under this specification. A new instruction sheet for this reformulated material shall be submitted by the manufacturer to the qualifying activity for approval (see 3.3 and section 10.3.2.3).

5.1.2 *Identification of Product*—The manufacturer shall identify each epoxy resin system submitted under this specification according to the type of container furnished for it (see Section 9). In addition, the manufacturer shall designate each epoxy system by a trade name and code number that shall be used to identify it.

5.2 *Qualification*—In the case of epoxy systems for which the purchaser requires qualification, the procurement document shall state that awards will be made only for epoxy systems that are, at the time set for opening for bids, qualified, according to the requirements in Section 3, for inclusion on the applicable qualified products list.

5.3 *Procurement Documents*—Procurement documents shall specify the following:

- 5.3.1 Title, number, and date of this specification,
- 5.3.2 Epoxy resin system type and manufacturer's trade name,
- 5.3.3 Date of manufacture,
- 5.3.4 Manufacturer's name and address,
- 5.3.5 Manufacturer's batch/lot designation,
- 5.3.6 Contract number,
- 5.3.7 Date of shipment,
- 5.3.8 Expiration dates when stored at 23 ± 2°C (73 ± 4°F),

5.3.9 Manufacturer's recommended storage temperature,

5.3.10 Quantity ~~required~~,

5.3.11 Level of packaging and packing ~~required~~, and

5.3.12 ~~Manufacturer's required~~, and

5.3.11 Manufacturer's certification that the batch and lot meet the requirements of this specification.

6. Quality Assurance Provisions

6.1 *Responsibility for Inspection*—Unless otherwise specified in the contract or purchase order, the supplier is responsible for the performance of all inspection requirements as specified herein. Except as otherwise specified in the contract or purchase order, the supplier is permitted to use any facility suitable for the performance of the inspection requirements specified herein, unless disapproved by purchaser. The purchaser reserves the right to perform any of the inspections set forth in the specification where such inspections are required to ensure that supplies and services conform to prescribed requirements.

6.2 *Classification of Tests*—The inspection and testing of the epoxy system shall be classified as qualification tests (see 6.3) and quality conformance tests (see 6.4).

6.3 *Qualification Tests*:

6.3.1 *Sampling Instruction*:

6.3.1.1 *Epoxy Resin System Samples*—The manufacturer shall submit two 1-qt samples of the base epoxy resin, along with the necessary curing agent, from a single-numbered production batch of material being presented for qualification. The manufacturer shall submit two additional 200-g kits of the two-part system (resin and curing agent) from the same production batch for storage life tests (7.3.4). These four 200-g kit epoxy resin samples shall each be from a batch of most recent production-scale manufacture, and are not required to be from the same batch as that used in preparing the duplicate panels specified in 6.3.1.3. All samples shall be identified as to:

- ~~(a)~~(1) ~~(a)~~ Name and address of manufacturer,
- ~~(b)~~(2) ~~(b)~~ Manufacturer's designation (trade name and code number),
- ~~(c)~~(3) ~~(c)~~ Type of epoxy resin,
- ~~(d)~~(4) Batch number,
- ~~(e)~~(5) Date of manufacture,
- ~~(f)~~(6) Date of submittal,
- ~~(g)~~(7) Expiration date, and
- ~~(h)~~(8) Identification of agency submitting the samples.

6.3.1.2 A statement indicating that the products have not been rebranded shall accompany the samples. If rebranded, the names of the original manufacturers and original designations of the products shall be indicated. All information submitted will be treated as confidential.

6.3.1.3 *Duplicate Panels*— The manufacturer shall submit, along with the epoxy material samples called for in 6.3.1.1, a set of three panels, prepared in accordance with the procedures described in 7.2.1-7.2.3, respectively. These three panels shall be duplicates of those used in the generation of data for the test report (6.3.2). These panels shall be prepared with epoxy resin samples from the same numbered batch, and shall be code marked the same as the panels from which the data in the test report (6.3.2) were obtained.

6.3.2 *Test Report*— A dated and numbered report, certified by notarized affidavit, shall be furnished, giving the results of all applicable tests listed in Tables 2-4. The individual specimen and average values for each test shall be reported (see section 10.3.2). Each value reported shall be shown as being for a uniquely numbered specimen, the numbering of which shall be coded in the report in such a manner as to clearly establish the particular panel from which the specimen was cut and the particular batch of epoxy resin with which said panel was prepared and the date of preparation. Coded identification of the epoxy resin batch shall include the respective dates of manufacture and sizes of batch. Dates on which the different tests were performed shall be shown in the test report. The test report shall also cover all the requirements of 6.3-6.3.4. The actual pressure, temperature, and time of curing used in the preparation of the test panels shall be reported in the test report.

6.3.3 *Instruction Sheet*—The manufacturer shall submit an instruction sheet attached to the test report in accordance with 3.3.

6.3.4 *Tests*—The qualification tests shall consist of all the tests of this specification (Section 7) and shall include approval of the manufacturer instruction sheet. These tests shall be conducted by an organization approved by the procuring agency. Any changes shall be subject to the approval of that procuring activity.

6.4 *Quality Conformance Tests*:

6.4.1 *Sampling*—Two 200-g kits of epoxy material (see 9.1), taken at random from the production batch submitted for qualification, shall be tested. One kit shall be used for acceptance tests and the other shall be retained for retest if necessary. The

storage conditions for the retained sample shall not exceed $23 \pm 2^{\circ}\text{C}$ ($73 \pm 4^{\circ}\text{F}$) and samples shall not be retained beyond the storage life.

6.4.2 *Tests*—Samples of each submitted lot of epoxy material delivered on contract or purchase order shall be subjected to the application life test described in 3.1.2. Lots shall be rejected if one or more of the specimens fail to comply with the requirements. Test reports, in duplicate, shall be furnished for all quality conformance tests and shall be signed by an authorized representative of the laboratory performing the test and by a designated representative of the procuring agency.

6.5 *Periodic Reevaluation*—Unless otherwise specified by the purchaser (see 6.1), epoxy material that has not passed the qualification tests, or that has previously passed the tests but has subsequently been modified in any manner, must be tested against this specification and shown to meet its requirements.

7. Test Methods

7.1 *Test Conditions*— Unless otherwise specified in the detailed test method, all specimens shall be conditioned at $23 \pm 2^{\circ}\text{C}$ ($73 \pm 4^{\circ}\text{F}$) and $50 \pm 5\%$ relative humidity for a period of at least 7 days.

7.2 Preparation of Test Panels :

7.2.1 *Preparation of Test Panels for Tensile Lap Shear* (Table 2)—A total of two panels shall be prepared as follows (see Fig. 1):

7.2.1.1 Place a flat base plate, (labelled *B* in Fig. 1) 38.1 by 35.6 cm minimum, (15 by 14 in.) upon a film of bagging material that is approximately 10 cm (4 in.) larger than the base plate in each direction (labelled *LBF* in Fig. 2).

7.2.1.2 Cover the base plate with a sheet of film to act as a release (labelled *RF* in Fig. 1).

7.2.1.3 Prepare a 27.9 by 25.4 cm (11 by 10 in.) piece of 0.317 cm ($\frac{1}{8}$ in.) thick ~~MIL-P-18177C~~, MIL-I-24768, G10 laminate for bonding by sanding the bonding surface with 400 grit sand paper to remove surface gloss. Remove the sanding dust using a clean cloth saturated with isopropyl alcohol.

7.2.1.4 Center the ~~MIL-P-18177~~, MIL-I-24768, G10 laminate section of the panel (labelled *P* in Figs. 1 and 2) onto the release film on the base plate.

7.2.1.5 Lay up a laminate of 20 nested plies (approximately 27.9 by 25.4 cm) (11 by 10 in.) of ~~MIL-C-9084C~~ SAE-AMS-C-9084 Type 7781 glass cloth impregnated with the epoxy resin system (labelled *C* in Figs. 1 and 2) directly on top of the G10 laminate (*P* in Figs. 1 and 2). The amount of resin to use to impregnate the glass cloth shall be selected so that the final cured laminate has a fiber content of $55 \pm 4\%$ by volume. All 20 plies shall be oriented so that the warp yarns in the fabric weave are in the 25.4 cm (10 in.) direction of the layup.

7.2.1.6 Cover the ~~MIL-C-9084C~~ SAE-AMS-C-9084 laminate with a release film that overhangs the laminate by at least 5 cm (2 in.) on all sides (Fig. 2).

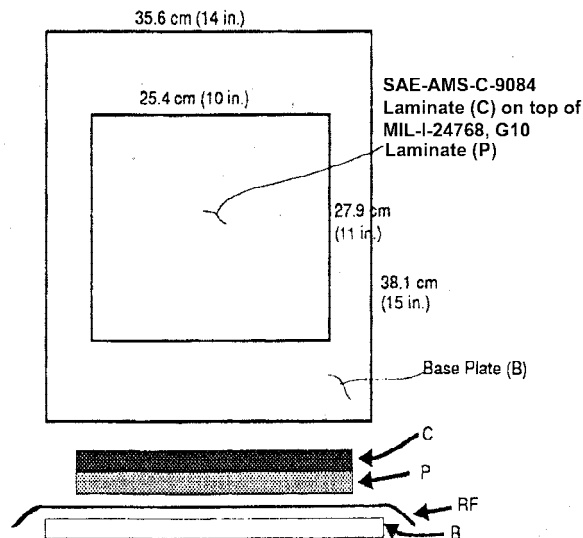

- G = MIL-C-9084C Laminate, 20 nested plies of MIL-C-9084C Type 7781 glass cloth impregnated with test epoxy resin system
 C = SAE-AMS-C-9084 Laminate, 20 nested plies of SAE-AMS-C-9084 Type 7781 glass cloth impregnated with test epoxy resin system
 P = MIL-P-18177, G10 laminate, 0.317 cm ($\frac{1}{8}$ in.) thick
 P = MIL-I-24768, G10 laminate, 0.317 cm ($\frac{1}{8}$ in.) thick
 RF = release film
 B = base plate

FIG. 1 Preparation of Test Panel for Tensile Lap Shear

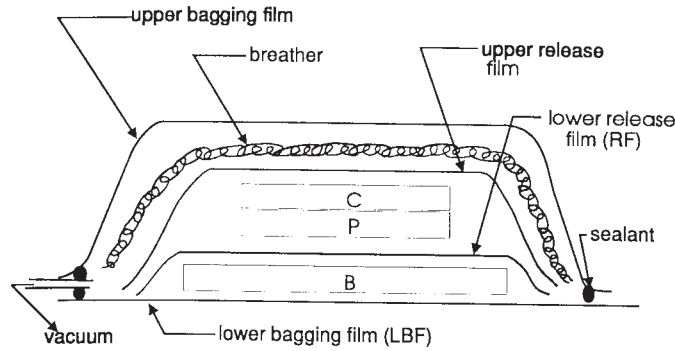

FIG. 2 Layup Scheme for Tensile Lap Shear Panel

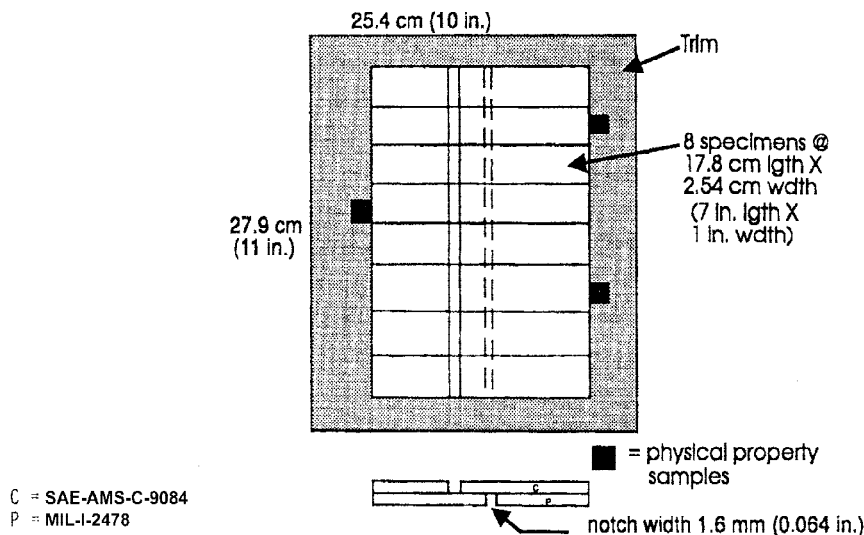

FIG. 3 Specimen Machining Diagram for Tensile Lap Shear Panel

7.2.1.7 Cover the upper release film with a layer of heavy fiberglass breather fabric to provide for a uniform venting of the vacuum bag during curing of the laminate (Fig. 2).

7.2.1.8 Place strip of sealant along the outer portion of the lower sheet of bagging material and fit a vacuum tube through the sealant (see Fig. 2).

7.2.1.9 Position an upper sheet of the bagging material over the layup stack and seal to the sealant around the edges (Fig. 2).

7.2.1.10 Apply a vacuum of up to 72 cm (28.5 in.) of mercury (14 psig) to the bag.

7.2.1.11 Smooth out the laminate and work out the air and excess resin using the flat edge of a smooth tool.

7.2.1.12 The entire bagged assembly is to be cured in accordance with the following conditions:

(a)(1) (a) Allow to cure, under vacuum, for 24 h at $23 \pm 2^\circ\text{C}$ ($73 \pm 4^\circ\text{F}$), and

(b)(2) (b) Remove vacuum bag and allow to cure for six additional days (a total of seven days) at $23 \pm 2^\circ\text{C}$ ($73 \pm 4^\circ\text{F}$) prior to further preparation.

7.2.1.13 The cured panel shall be used to prepare tensile lap shear specimens (see 7.3.1). Fig. 3 illustrates the specimen machining diagram. Physical property specimens shall also be obtained from the cured panel and used to determine cured laminate specific gravity (Test Methods D 792), resin content (Test Method D 2584), fiber content (Test Method D 2584), and void content (Test Methods D 2734).

7.2.2 Preparation of Test Panel for Apparent Horizontal Shear Strength (Table 3) —A panel shall be prepared as follows (see Figs. 4 and 5):

7.2.2.1 Place a flat base plate (labelled B in Fig. 5) 25.4 by 25.4 cm minimum (10 by 10 in.) upon a film of bagging material that is approximately 10 cm (4 in.) larger than the base plate in each direction.

7.2.2.2 Cover the base plate with a sheet of film to act as a release (Fig. 5).

7.2.2.3 Layup a laminate of 20 nested plies (approximately 15.2 by 15.2 cm (6 by 6 in.)) of MIL-C-9084 C SAE-AMS-C-9084

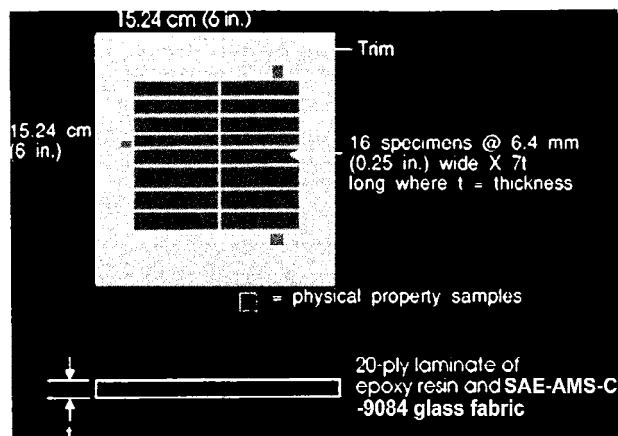

FIG. 4 Apparent Horizontal Shear Strength Panel

C = SAE-AMS-C-9084, 20 nested plies of SAE-AMS-C-9084 Type 7781 glass cloth impregnated with test resin system
 B = base plate

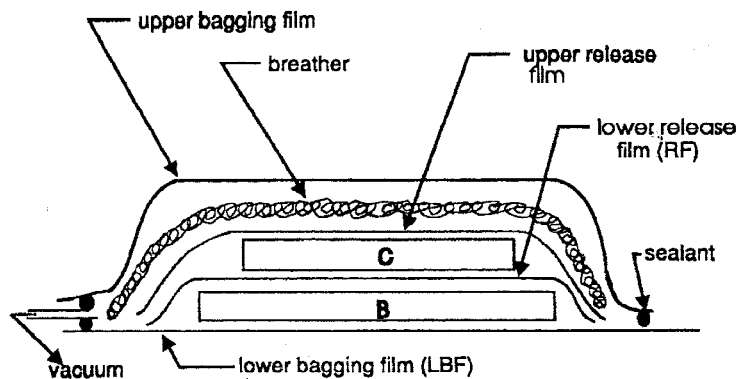

FIG. 5 Layup Scheme for Apparent Horizontal Shear Panel

type 7781 glass cloth impregnated with the epoxy resin system (Fig. 4 and item (c) in Fig. 5) directly on top of the release film. The amount of resin used to impregnate the glass cloth shall be selected so that the final cured laminate has a fiber content of $55 \pm 4\%$ by volume.

7.2.2.4 Cover the MIL-C-9084/SAE-AMS-C-9084 laminate with a release film that overhangs the laminate by at least 5 cm (2 in.) on all sides (see Fig. 5).

7.2.2.5 Cover the upper release film with a layer of heavy fiberglass breather fabric to provide for a uniform venting of the vacuum bag during curing of the laminate (see Fig. 5).

7.2.2.6 Place a strip of sealant along the outer portion of the lower sheet of bagging material and fit a vacuum tube through the sealant (see Fig. 5).

7.2.2.7 Position an upper sheet of the bagging material over the layup stack and seal to the sealant around the edges (see Fig. 5).

7.2.2.8 Apply a vacuum of up to 72 cm (28.5 in.) of mercury (14 psig) to the bag.

7.2.2.9 Smooth out the laminate and work out the air and excess resin using the flat edge of a smooth tool.

7.2.2.10 The entire bagged assembly is to be cured in accordance with the following conditions:

(a)(1) (a) Allow to cure under vacuum, for 24 h at $23 \pm 2^\circ\text{C}$ ($73 \pm 4^\circ\text{F}$), and

(b)(2) (b) Remove vacuum bag and allow to cure for six additional days (a total of seven days) at $23 \pm 2^\circ\text{C}$ ($73 \pm 4^\circ\text{F}$) prior to further preparation.

7.2.2.11 The cured panel shall be used to prepare apparent horizontal shear specimens (see 7.3.2). Fig. 4 illustrates the specimen machining diagram. Physical property specimens shall also be obtained from the cured panel and used to determine cured laminate specific gravity (Test Methods D 792), resin content (Test Method D 2584), fiber content (Test Method D 2584), and void content (Test Methods D 2734).

7.2.3 Preparation of Test Panel for Flatwise Tension Test (Table 5)—A panel shall be prepared as follows (Figs. 6 and 7):

7.2.3.1 Place a flat base plate 40.5 by 40.5 cm (16 by 16 in.) minimum upon a film of bagging material that is approximately 10 cm (4 in.) larger than the base plate in each direction.

7.2.3.2 Cover the base plate with a sheet of film to act as a release.

7.2.3.3 Layup a laminate of 8 plies (approximately 30.5 by 30.5 cm) (12 by 12 in.) of ~~MIL-C-9084C~~ SAE-AMS-C-9084 Type 7781 glass cloth impregnated with the epoxy resin system. The ratio of resin-to-glass cloth shall be 0.1 g resin/in.² (0.0155 g/cm²) of glass cloth. Position the layup in the center of the base plate.

7.2.3.4 Place a 30.5 by 30.5-cm by 5-cm thick (12 by 12 by 2-in. thick) piece of honeycomb core (Specification E 1091, Type I or II) on top of the 8-ply wet layup prepared in 7.2.3.3.

7.2.3.5 Layup a laminate of 8 plies (approximately 30.5 by 30.5 cm (12 by 12 in.)) of ~~MIL-C-9084C~~ SAE-AMS-C-9084 Type 7781 glass cloth impregnated with the epoxy resin system onto the top of the honeycomb core. Use the same ratio of resin-to-glass cloth as in 7.2.3.3.

7.2.3.6 Cover the sandwich layup with a release film that extends down the sides and beyond layup by at least 5 cm (2 in.) on all sides (Fig. 6).

7.2.3.7 Surround the sandwich layup with 5-cm (2-in.) high spacer blocks (see Fig. 6) to prevent the vacuum bag from crushing the edges of the sandwich layup.

7.2.3.8 Cover the upper release film and the spacer blocks with a layer of heavy fiberglass breather fabric to provide for a uniform venting of the vacuum bag during cure of the sandwich skins (Fig. 6).

7.2.3.9 Place a strip of sealant along the outer portion of the lower sheet of bagging material and fit a vacuum tube through the sealant (see Fig. 6).

7.2.3.10 Position an upper sheet of the bagging material over the layup extending beyond the sealant on the lower film. Allow enough excess film so that when it draws down around the layup during vacuum application it does not tear.

7.2.3.11 Apply a vacuum of up to 72 cm (28.5 in.) of mercury (14 psig) to the bag.

7.2.3.12 The entire bagged assembly is to be cured in accordance with the following conditions:

(a)(1) (a) Allow to cure, under vacuum, for 24 h at 23 ± 2°C (73 ± 4°F), and

(b)(2) (b) Remove vacuum bag and allow to cure for six additional days (a total of seven days) at 23 ± 2°C (73 ± 4°F) prior to further preparation.

7.2.3.13 The cured panel shall be used to prepare 5 by 5 cm (2 by 2 in.) flatwise tensile specimens (see Fig. 7).

7.3 Testing—Specimens for each of the following tests shall be held at the test temperature for the times listed below before loading is started in order to allow the specimen to reach the test temperature or to minimize dryout, or both.

Test Conditions	Hold Time
-40°C (-40°F), dry	15 min
80°C (176°F), wet	3 min
93°C (200°F), wet	3 min

7.3.1 Tensile Lap Shear Strength (Table 2)—Five specimens of the type illustrated in Fig. 3 shall be tested at each test condition listed in Table 2.

7.3.1.1 Preparation of Specimens—Sixteen specimens 2.54 cm (1 in.) wide and having a 1.27 cm (½ in.) lap joint prepared by kerf cuts into the layup area as illustrated in Fig. 3 shall be cut from the panels prepared in 7.2.1. Specimens cut from each panel shall be identified with the panel from which they were cut. No more than three specimens from either of the two panels made shall be tested at any one of the conditions listed in Table 2.

7.3.1.2 Lap Shear Strength Test (Table 2)—This test shall be performed in accordance with the procedures described in Test Method D 3165. Data recorded during the test and reported shall be in accordance with the requirements of Test Method D 3165. The nature and percent of failure, such as cohesive (failure within the adhesive) or adhesive failure (debonding from the adherend) shall be reported. The average and minimum strengths of these specimens shall equal or exceed those specified in Table 2.

7.3.2 Apparent Horizontal Shear Strength (Table 3)—Five specimens of the type illustrated in Fig. 4 and Fig. 8 shall be tested

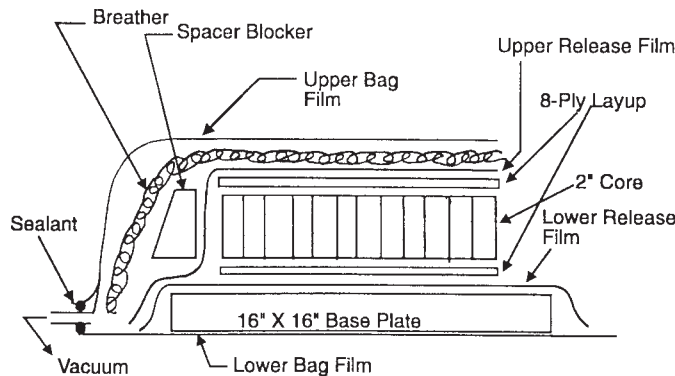

FIG. 6 Honeycomb Test Panel Layup Scheme

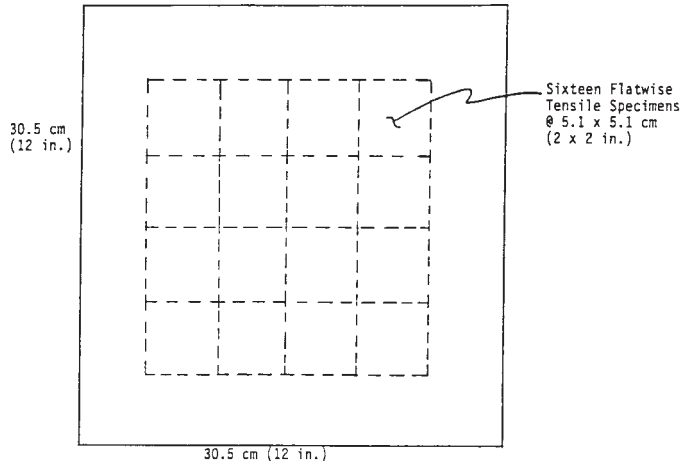

FIG. 7 Diagram for Flatwise Tensile Specimens from Honeycomb Test Panel

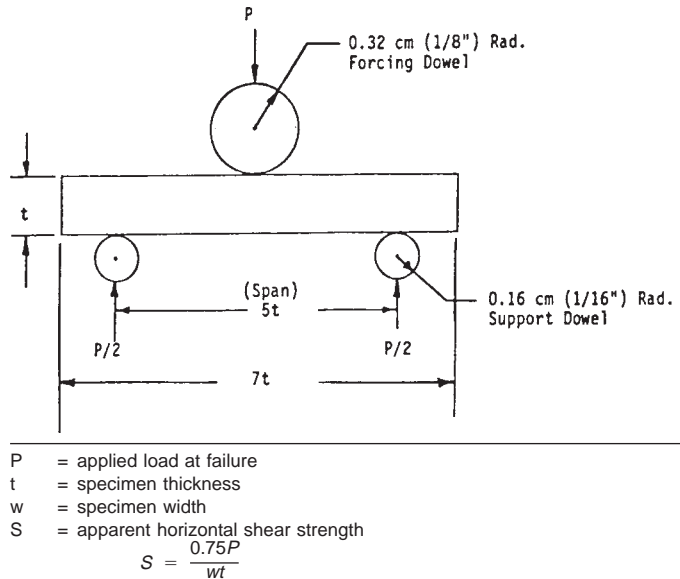

FIG. 8 Three-Point Loading for Apparent Horizontal Shear Test

at each of the listed test conditions in Table 3.

7.3.2.1 *Preparation of Specimens*—From the panel prepared in 7.2.2, cut specimens 0.635 cm (0.25 in.) wide. The lengths shall be cut to provide a length to thickness ratio, L/t , of 7 (see Fig. 8).

7.3.2.2 *Apparent Horizontal Shear Strength Test*—Test in accordance with Fig. 8 and the procedures described in Test Method D 2344. The test span shall have a length to thickness ratio of five (Test Method D 2344). The average and minimum strengths of the specimens shall equal or exceed that specified in Table 3.

7.3.3 *Flatwise Tension* (Table 4)—Five specimens shall be tested at each of the listed test conditions.

7.3.3.1 *Preparation of Specimens*—From the panel prepared in 7.2.3 cut specimens (5 by 5 cm (2 by 2 in.)) (see Fig. 7). This shall be done on a bandsaw with a sharpened blade, or other tool that provides a precise cut without ripping or overheating the edges of the specimen. The specimens to be tested must be bonded to loading blocks in accordance with the requirements of Test Method C 297. The surfaces of the loading blocks must be clean and sanded to enhance bonding. The sandwich skins shall be sanded with 120 to 160 grit sandpaper and wiped clean of sanding dust with a clean cloth saturated with isopropyl alcohol or trichloroethane. A room temperature curing epoxy adhesive capable of developing full strength in 24 h shall be used to bond the loading blocks to the specimens. This adhesive must retain enough strength at 80°C (176°F) to force failure in the core or core-to-skin bondline. The wet aged specimens shall be bonded to the loading blocks with an adhesive that will develop full strength in 1 h or less at room temperature or in the 60°C (140°F), 95 to 100 % RH exposure environment in order to minimize specimen dryout. The loading blocks shall be aligned carefully with the sandwich specimens so that the edges are flush and the specimen will be loaded uniformly.

7.3.3.2 *Flatwise Tension Test*—Test and report data in accordance with the requirements in Test Method C 297. The nature of the adhesive fillets formed along the core cell walls on both the upper and lower skins and the nature of the failure shall be

recorded.⁴ The average and minimum strengths of these specimens shall equal or exceed that specified in Table 4.

7.3.4 *Storage Life Tests*—Two 200-g kits of the epoxy material being submitted for qualification under this specification shall be stored at $23 \pm 3^{\circ}\text{C}$ ($73 \pm 5^{\circ}\text{F}$) for a period of 12 months. At the end of the storage period, one of these kits shall be tested for, and meet, the application life and viscosity requirements of 3.1.2 and 3.1.5. It shall also be tested for, and meet, the 23°C (73°F) apparent horizontal shear strength and flatwise tensile strength requirements of 7.3.2.2 and 7.3.3.2. If the original test set fails, another test, using the second 200-g kit shall be conducted. Like failure in retest shall cause rejection of the adhesive.

7.3.5 *Room Temperature Cure Rate Verification*—Five specimens of each type required in Table 1 shall be prepared in accordance with the procedures outlined in 7.2.1 and 7.2.2. These specimens shall be cured at $23 \pm 2^{\circ}\text{C}$ ($73 \pm 4^{\circ}\text{F}$) for 24 h. Machining of the individual specimens from these 24-h cured panels shall be accomplished as quickly as possible after the 24-h period is complete so that all testing is completed no later than 30 h after the start of cure. These specimens shall be tested at the $23 \pm 2^{\circ}\text{C}$ ($73 \pm 4^{\circ}\text{F}$), dry condition in accordance with the procedures outlined in 7.3.1-7.3.2. The average strength of these specimens shall equal or exceed the values listed in Table 1 for the 23°C , dry test condition.

8. Acceptance Inspection Requirements

8.1 *Prewieghed Mixing Kits*—A random sample of filled containers (9.1) shall be selected from each lot in accordance with MIL-STD-105916 at inspection level 1 and at acceptance quality level (AQL) of 2.5 % defective, to verify conformance to all requirements of this specification regarding fill, closure and marking.

8.1.1 *Filled Containers*—Each sample-filled container, selected in accordance with 8.1 shall be examined for defects of the container and closure for evidence of leakage, and for unsatisfactory markings. Each sample-filled container shall also be weighed to determine the amount of contents. Any container in the sample having one or more defects or under the required fill, shall be rejected, and if the number of defective containers in any sample exceeds the acceptance number for the specified sampling plan of MIL-STD-105916, the lot represented by the sample shall be rejected. Rejected lots shall not be resubmitted for acceptance test unless the contractor has removed or repaired all nonconforming containers.

9. Preparation for Delivery

9.1 *Unit Packaging*—The two-part epoxy resin system covered by this specification shall be packaged in preweighed kits in 100, 200, and 400-g sizes. The material shall be packaged in non-breakable type containers that will not leak or react with the ingredients. The kits shall be supplied with a suitable means of injecting the mixed epoxy material into a 2.49-mm (0.098-in.) diameter hole.

9.2 ~~Packaging and Packing:~~

9.2.1 ~~Packaging of epoxy systems covered by this specification~~

~~Packaging shall be in accordance with Federal Standard No. 102, Level A or C, as specified.~~

~~9.2.2 Level A—The two or more epoxy material components of the kit in individual containers shall be packaged as a kit in a sealed plastic bag, supplier's standard practice and packaged in boxes conforming to PPP-B-566 or PBB-B-676.~~

~~9.2.3 Level C—Epoxy resin materials shall be packaged in accordance with manufacturer's commercial practice.~~

~~9.2.4 Packing—Packing shall be Level A, B, or C as specified (see 10.2).~~

~~9.2.4.1 Levels A and B—Epoxy systems packaged as specified in 9.2.2 and in quantities as specified (see 9.1) shall be packed in a snugly fitted domestic type shipping container conforming to Specification PPP-B-636, applicable regulations. The container shall be sealed in accordance with the Appendix to the shipping container specification.~~

~~9.2.4.2 Level C—The kits Kits shall be packed to ensure carrier acceptance and safe delivery to the destination in containers complying with rules and regulations applicable to the mode of transportation.~~

9.3 *Marking*—In addition to marking required by the contractor or order, the interior and exterior shipping containers shall be marked in accordance with MIL-STD-129 and shall include the labeling specified in 9.3.1.

9.3.1 The product shall be clearly and legibly labeled and shall include the following information:

9.3.1.1 Epoxy Resin System, Honeycomb Panel, Repair, Field,

9.3.1.2 Glass-Resin Composite Bonding Specification,

9.3.1.3 Epoxy Type,

9.3.1.4 Kit Type,

9.3.1.5 Date of manufacture (month and year),

9.3.1.6 Manufacturer's product designation,

9.3.1.7 Manufacturer's batch/lot identification,

9.3.1.8 Contract number,

9.3.1.9 Date of shipment,

9.3.1.10 Expiration date,

9.3.1.11 Manufacturer's recommended storage temperature range,

⁴ Normal failure modes are debonding along the core-skin interface or core tearing but other failure modes may be encountered.

- 9.3.1.12 Quality of containers,
- 9.3.1.13 Size of containers, and
- 9.3.1.14 Manufacturer's certification that the batch and lot meet the requirements of this specification.

10. Ordering and Qualification Information

10.1 *Ordering Date*— Purchasers shall exercise any desired options offered herein and procurement documents shall specify the following:

- 10.1.1 Title, number, and date of this specification.
- 10.1.2 Epoxy system code number, and trade name (see 5.1.2).
- 10.1.3 Quantity, size, and description of kits of epoxy material required.
- 10.1.4 Level of packaging and packing required (see 9.2).

10.2 *Qualification Testing*:

10.2.1 *Qualification*— With respect to products requiring qualification, awards will be made only for products that are at the time set for opening of bids, qualified for inclusion in the applicable Qualified Products List whether or not such products have actually been so listed by that date.

10.2.2 In authorizing qualification tests, it shall be stated in the Letter of Authorization that the following information and samples shall be furnished at no cost.

10.2.2.1 Notorized test report (6.3.2) listing all data obtained with a single batch of the epoxy system in evaluation tests performed in accordance with this specification.

10.2.2.2 A duplicate set of bonded test panels prepared with the same batch of epoxy material and under the same bonding conditions as used to obtain the data given in the test report (see 6.3.2 for panel preparation and identification of panels with epoxy material batch).

10.2.2.3 Instruction sheet listing all of the information as required in 3.3 and including storage life recommendations.

10.2.2.4 Sample of epoxy resin and curing agent. This sample shall be from a batch of recent production scale manufacture and may be from a different batch than that used in preparing the above test panels. This sample shall be properly packaged for storage (see Section 9) and shall be properly identified (see 5.1.2).

10.2.2.5 The manufacturer shall pay the transport charges to and from the designated point where tests are to be made. In the case of failure of the sample or samples submitted, consideration will be given to the request of the manufacturer for additional tests only after it has been clearly shown that changes have been made in the product that are sufficient to warrant additional tests.

10.2.3 Epoxy resin systems conforming to the other requirements of this specification are permitted, at the option of the qualifying activity, to be placed on the Qualified Products List of products qualified under the specification (see 10.2.1) prior to the completion of the storage life tests. Modifications of the manufacturer's storage life recommendations or removal of the resin/adhesive from the Qualified Products List will be necessary, if subsequently the resin/adhesive does not pass the storage life test.

11. Keywords

- 11.1 adhesive bond; composite; epoxy; properties; repair; resin; sandwich; structures

ASTM International takes no position respecting the validity of any patent rights asserted in connection with any item mentioned in this standard. Users of this standard are expressly advised that determination of the validity of any such patent rights, and the risk of infringement of such rights, are entirely their own responsibility.

This standard is subject to revision at any time by the responsible technical committee and must be reviewed every five years and if not revised, either reapproved or withdrawn. Your comments are invited either for revision of this standard or for additional standards and should be addressed to ASTM International Headquarters. Your comments will receive careful consideration at a meeting of the responsible technical committee, which you may attend. If you feel that your comments have not received a fair hearing you should make your views known to the ASTM Committee on Standards, at the address shown below.

This standard is copyrighted by ASTM International, 100 Barr Harbor Drive, PO Box C700, West Conshohocken, PA 19428-2959, United States. Individual reprints (single or multiple copies) of this standard may be obtained by contacting ASTM at the above address or at 610-832-9585 (phone), 610-832-9555 (fax), or service@astm.org (e-mail); or through the ASTM website (www.astm.org).