



Standard Test Method for Rubber Property—Abrasion Resistance (Rotary Drum Abrader)¹

This standard is issued under the fixed designation D 5963; the number immediately following the designation indicates the year of original adoption or, in the case of revision, the year of last revision. A number in parentheses indicates the year of last reapproval. A superscript epsilon (ϵ) indicates an editorial change since the last revision or reapproval.

1. Scope

1.1 This test method covers the measurement of abrasion resistance of rubbers (vulcanized thermoset rubbers and thermoplastic elastomers) that are subject to abrasive/frictional wear in actual service. The abrasion resistance is measured by moving a test piece across the surface of an abrasive sheet mounted to a revolving drum, and is expressed as volume loss in mm^3 or abrasion resistance index in percent. For volume loss, a smaller number indicates better abrasion resistance, while for the abrasion resistance index, a smaller number denotes poorer abrasion resistance.

1.2 Test results obtained by this test method shall not be assumed to represent the wear behavior of rubber products experienced in actual service.

1.3 The values stated in SI units are to be regarded as the standard. The values in parentheses are for information only.

1.4 *This standard does not purport to address all of the safety concerns, if any, associated with its use. It is the responsibility of the user of this standard to establish appropriate safety and health practices and determine the applicability of regulatory limitations prior to use.*

2. Referenced Documents

2.1 ASTM Standards:

- D 297 Test Methods for Rubber Products—Chemical Analysis²
- D 1765 Classification System for Carbon Blacks Used in Rubber Products²
- D 2240 Test Method for Rubber Property—Durometer Hardness²
- D 3182 Practice for Rubber—Materials, Equipment, and Procedures for Mixing Standard Compounds and Preparing Standard Vulcanized Sheets²
- D 4483 Practice for Determining Precision for Test Method Standards in the Rubber and Carbon Black Industries³

¹ This test method is under the jurisdiction of ASTM Committee D-11 on Rubber and is the direct responsibility of Subcommittee D11.15 on Degradation Tests.

Current edition approved Nov. 10, 1997. Published May 1998.

This test method is an adaptation of ISO Standard 4649 (1985 revision), Rubber—Determination of Abrasion Resistance Using a Rotating Cylindrical Drum Device, and is being coordinated with a current draft revision of that standard (see Appendix X1).

² Annual Book of ASTM Standards, Vol 09.01.

³ Annual Book of ASTM Standards, Vol 09.02.

2.2 Other Standards:

- DIN 53516 Determination of Abrasion Resistance⁴
- ISO 868 Plastics and Ebonite—Determination of Indentation Hardness by Means of a Durometer (Shore Hardness)⁵
- ISO 2393 Rubber Test Mixes—Preparation, Mixing and Vulcanization—Equipment and Procedures⁵
- ISO 2781 Rubber, Vulcanized—Determination of Density⁵
- ISO 4649 Rubber—Determination of Abrasion Resistance Using a Rotating Cylindrical Drum Device⁵
- ISO 5725 Precision of Test Methods—Determination of Repeatability and Reproducibility for a Standard Test Method by Interlaboratory Tests⁵
- ISO 9298 Rubber Compounding Ingredients—Zone Oxide Test Methods⁵

3. Terminology

3.1 *abrasion loss, A*, (mm^3), *n*—the volume loss of a defined rubber test piece determined by sliding the test piece under specified conditions over the surface of an abrasive sheet of “nominal abrasiveness,” S_O , mounted to a rotating drum of specified dimensions.⁶

3.1.1 *Discussion*—The designation A_A is used to indicate that the test was run in accordance with Method A.

3.2 *abrasion resistance index ARI* (%), *n*—the ratio of the volume loss of a Standard Rubber to that of a test rubber expressed in percent, with the volume loss determined by sliding a defined rubber test piece under specified conditions over the surface of an abrasive sheet of known abrasiveness S (180 to 220 mg) mounted to a rotating drum of specified dimensions.

3.2.1 *Discussion*—The designations ARI_A , ARI_B , ARI_C , and ARI_D are used to indicate that the test was run in accordance with Method A, B, C or D, respectively.

3.3 “nominal abrasiveness,” S_O of the abrasive sheet, (mg),

⁴ Available from DIN (Deutsches Institut fuer Normung), Burggrafenstrasse 6, Postfach 1107, W-1000 Berlin 30, Germany.

⁵ Available from American National Standards Institute, 11 W. 42nd St., 13th Floor, New York, NY 10036.

⁶ This corresponds to the test method of DIN 53516 and to Method A (Relative volume loss) of ISO 4649:1985. The same calculation could be made for the other test methods if the proper value for the “nominal abrasiveness,” S_O , for the test method were known or assumed. (150 mg has been indicated as a possible value for Method D but its accuracy has not been established to the degree of the Method A value.)

n —a specified (theoretical) mass loss of 200 mg of a defined test piece of a Standard Rubber, obtained by sliding the test piece under specified conditions over the surface of the abrasive sheet mounted to a rotating drum of specified dimensions.

3.4 *abrasiveness, S of the abrasive sheet*, (mg), n —the actual mass loss, within a specified range of 180 to 220 mg, of a defined test piece of a Standard Rubber, obtained by sliding the test piece under specified conditions over the surface of the abrasive sheet mounted to a rotating drum of specified dimensions.

3.5 *Standard Rubber*—A natural rubber compound of specified composition, mixed and vulcanized under defined conditions.

3.5.1 *Discussion*—Standard Rubber # 1 is used to determine the abrasiveness, S , of the abrasive sheet and to ensure that S is within the specified range of 180 to 220 mg. The ratio of the “nominal abrasiveness,” S_O , and the actual abrasiveness, S , is used to correct the abrasion loss of a test rubber for any deviation of the abrasiveness of the abrasive sheet from the specified “nominal abrasiveness” (200 mg).

4. Summary of Test Method

4.1 This test method provides procedures for preparing cylindrical test pieces of specified dimensions from vulcanized thermoset rubbers or thermoplastic elastomers and for evaluating their abrasion resistance by sliding a test piece across the surface of an abrasive sheet attached to a rotating drum. It also describes the preparation and compliance testing of a Standard Rubber (see Annex A1).

4.2 The test is performed under specified conditions of contact pressure, sliding distance, and travel speed of the test piece, rotational speed of the drum, and degree of abrasiveness of the abrasive sheet.

4.3 The abrasiveness, S , of the abrasive sheet is defined by the mass loss in mg of a test piece prepared from Standard Rubber #1 when tested under the same specified conditions.

4.4 Four different methods may be used to test the abrasion resistance. Method A, uses a *non-rotating* test piece and Method B a *rotating* test piece, both utilizing Standard Rubber #1 as the reference. Methods C and D use Standard Rubber #2 as reference with a *non-rotating* and *rotating* test piece, respectively. The rotating test pieces provide, in many cases, a more uniform abrasion wear pattern.

4.5 The abrasion resistance, A_A , obtained in accordance with Method A is reported as abrasion (volume) loss in mm^3 , calculated from the mass loss of the test piece, density of the test rubber and the abrasiveness of the abrasive sheet in relation to the “nominal abrasiveness,” S_O , defined by a mass loss of 200 mg. A smaller number indicates a higher resistance to abrasion.

4.6 The abrasion resistance, ARI_{A-D} , obtained in accordance with Methods A, B, C and D is reported as the abrasion resistance index in percent, calculated from the mass losses and densities of the Standard Rubbers and test rubbers. A smaller number indicates a lower resistance to abrasion.

4.7 The mass loss obtained by the different methods can differ and the same method shall therefore be used if mass (and volume) losses are to be compared directly.

5. Significance and Use

5.1 Abrasion resistance is a performance factor of paramount importance for many rubber products, such as tires, conveyor belts, power transmission belts, hoses, footwear, and floor covering. A test capable of measuring resistance to abrasion of rubber, including uniformity of wear behavior under abrasive/frictional service conditions is therefore highly desirable.

5.2 This test method may be used to estimate the relative abrasion resistance of different rubbers. Since conditions of abrasive wear in service are complex and vary widely, no direct correlation between this accelerated test and actual performance can be assumed.

5.3 This test method is suitable for comparative testing, quality control, specification compliance testing, referee purposes, and research and development work.

6. Limitations

6.1 Test pieces containing voids or porosity, or both, will yield unreliable test results.

6.2 Test pieces that bounce (chatter) over the surface of the abrasive sheet rather than running smoothly will produce inaccurate test results.

6.3 Test pieces that tend to extensively smear the surface of the abrasive sheet will provide meaningless test results.

6.4 Test results obtained under any of the above conditions shall not be used to reach conclusions regarding the relative abrasion resistance of rubbers.

7. Apparatus and Materials

7.1 *Abrasion Tester*.⁷

7.1.1 The abrasion tester consists of a machine frame holding a laterally movable test piece holder, a rotary cylindrical drum to which an abrasive sheet can be fastened and a drive system as shown in Fig. 1. Dimensions are given in Fig. 2.

7.1.2 The diameter of the cylindrical drum shall be 150.0 ± 0.2 mm (5.906 ± 0.008 in.) and its length approximately 500

⁷ A suitable tester can be obtained under the name Zwick 6102 Abrasion Tester, Item No. H04.6102.00 from CaliTek, Div. of SATEC, P.O. Box 2347, Riverview, MI 48192 or from Zwick GmbH & Co., August Nagel Strasse 11, Postfach 4350, D 89079 Ulm, Germany.

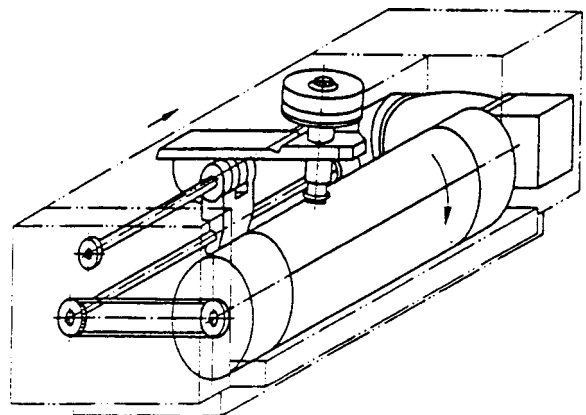

FIG. 1 Abrasion Tester

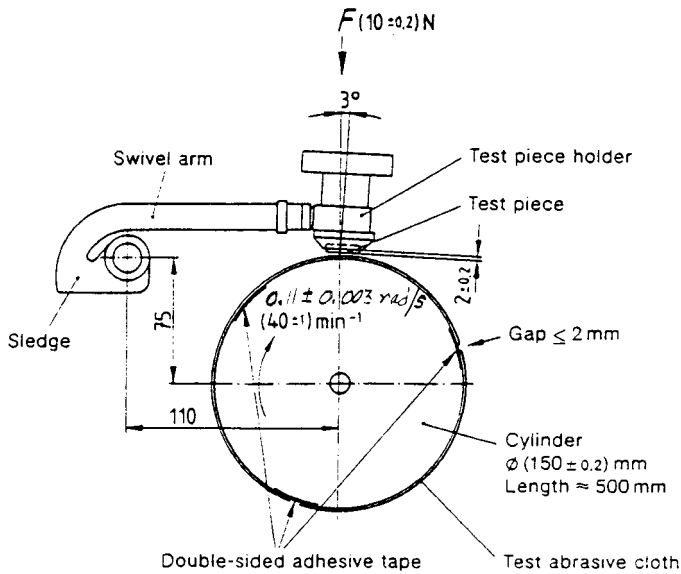

FIG. 2 Side View and Dimensions of Abrasion Tester

mm (20 in.), operating at a rotational frequency of $0.11 \text{ rad/s} \pm 0.003 \text{ rad/s}$ ($40 \pm 1 \text{ rpm}$).

7.1.3 The abrasive sheet shall be bonded tightly to the drum using three evenly spaced double faced pressure-sensitive adhesive tapes, extending the full length of the drum. The tapes shall be about 50 mm (2 in.) wide and not more than 0.2 mm (0.008 in.) thick. The gap where the ends of the abrasive sheets meet on the adhesive tapes shall not exceed 2 mm (0.08 in.).

7.1.4 It is mandatory that the abrasive sheet is bonded to the drum in the direction of rotation marked on the surface or back of the sheet.

7.1.5 The test piece holder shall be mounted on a pivoted swivel arm, which can be swung into vertical position to insert and remove the test piece (see Note 1).

NOTE 1—It is recommended to install a device preventing the test piece holder and abrasive sheet from coming into contact and damaging each other.

7.1.6 Suitable attachments may be provided to rotate the test piece around its own axis during the test run by rotation of the test piece holder (Methods B and D). The test piece shall rotate at the rate of 1 revolution for each 50 revolutions of the cylindrical drum with the abrasive sheet fastened to the drum.

7.1.7 The center axis of the test piece holder shall have an angle of 3° to the perpendicular in the direction of rotation and the center of the test piece shall be within $\pm 1 \text{ mm}$ ($\pm 0.04 \text{ in.}$) directly above the longitudinal axis of the drum.

7.1.8 The design of the swivel arm and holder shall be such that the test piece is pressed against the abrasive sheet with a force of $10.0 \pm 0.2 \text{ N}$ ($2.25 \pm 0.04 \text{ lbf}$). Both swivel arm and holder shall be free from vibration during operation.

7.1.9 The test piece holder shall consist of a cylindrical opening with an adjustable diameter of at least 15.5 mm (0.610 in.) to 16.3 mm (0.642 in.) and a device for adjusting the length of the test piece protruding from the opening to $2.0 \pm 0.2 \text{ mm}$ ($0.08 \pm 0.008 \text{ in.}$).

7.1.10 The swivel arm with the test piece holder is connected to a worm gear that moves the holder on a guide rod

laterally across the surface of the abrasive sheet attached to the cylindrical drum. The lateral displacement shall be approximately 4.2 mm (0.165 in.) per revolution of the drum, so that the test piece passes only four times across the same area of the sheet during one test cycle.

7.1.11 Placement of the holder with the test piece on the drum at the beginning of the test and removal at the end shall be automatic. The normal length of the abrasion path shall be $40.0 \pm 0.2 \text{ m}$ ($131.2 \pm 0.7 \text{ ft}$). This is equivalent to about 84 revolutions when allowing for the thickness of 1 mm (0.04 in.) for the abrasive sheet.

7.1.12 For special cases of very high volume loss, half the length of the abrasion path, that is, $20 \pm 0.1 \text{ m}$ ($65.6 \pm 0.3 \text{ ft}$), equivalent to roughly 42 revolutions, may be used.

7.1.13 The test machine may be equipped with a vacuum hose and a brush that contacts the drum and aids in the removal of debris.

7.2 Abrasive Sheet.⁸

7.2.1 Corundum (aluminum oxide) of grit 60 bonded to a carrier sheet of at least 400 mm (15.8 in.) width, $474 \pm 1 \text{ mm}$ ($18.66 \pm 0.04 \text{ in.}$) length and an average thickness of 1 mm (0.04 in.) shall be used as the abrasive medium.

7.2.2 The sheets shall be of an abrasiveness as to cause a mass loss between 180 and 220 mg when tested over an abrasion path of 40 m (131.2 ft) using a non-rotating test piece (Method A) of Standard Rubber #1 specified in Section 8.

7.2.3 Since the abrasiveness of virgin abrasive sheets is usually higher than desired, it is necessary to blunt the sheets with one or two test runs using a steel test piece in place of the Standard Rubber to bring it into the desired range. The direction of rotation used for blunting shall be marked on the sheets.

7.2.4 After blunting, the abrasive sheets shall be thoroughly cleaned by brushing, blowing, or suction and two test runs with the Standard Rubber shall be made.

7.2.5 Test results obtained with abrasive sheets, thus calibrated, are more consistent, and it is normally possible to run several hundred single tests using the same sheet.

7.3 Test Piece Cutting Tool.⁹

7.3.1 The circular cutting tool for test piece preparation is a hollow drill made from hardened metal with dimensions shown in Fig. 3.

7.3.2 The rotational frequency of the drill should be about 2.65 rad/s (1000 rpm) and even higher for rubbers with a hardness of less than 50 Shore A (see Test Method D 2240 and ISO 868).

7.3.3 When cutting, the cutting edge of the drill shall be lubricated with water containing a wetting agent.

⁸ Suitable abrasive sheets can be obtained under Item No. H04.6102.040 from CaliTek, Div. of SATEC, P.O. Box 2347, Riverview, MI 48192 or from Bundesanstalt für Materialforschung und-prüfung (BAM), Unter den Eichen 87, Postfach POB, D 12200 Berlin, Germany.

⁹ A suitable cutting tool can be obtained under Item No. H04.6102.060 from CaliTek, Div. of SATEC, P.O. Box 2347, Riverview, MI 48192 or from Zwick GmbH & Co., August Nagel Strasse 11, Postfach 4350, D 89079 Ulm, Germany.

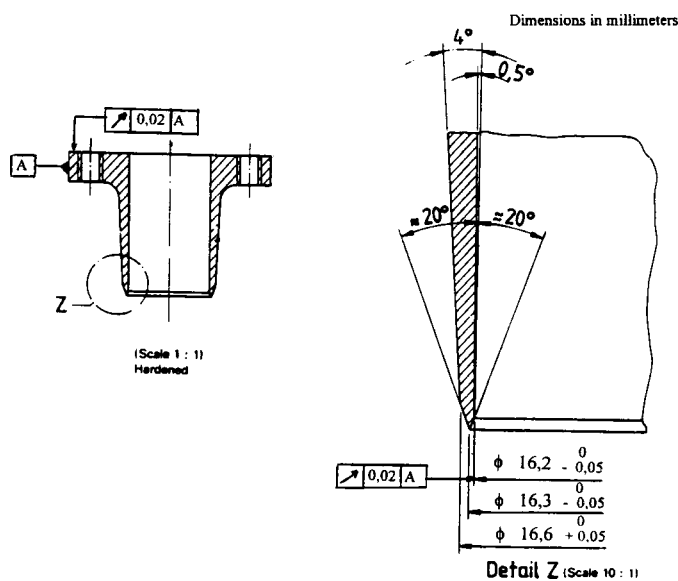

FIG. 3 Hollow Drill for Test Piece Preparation

8. Standard Rubber

8.1 Sheets of Standard Rubber may be obtained commercially¹⁰ or prepared in-house, following the directions given in Annex A1.

8.2 If prepared in-house, it is mandatory to test a commercially obtained reference sheet for comparison.

8.3 Standard Rubber sheets shall be stored under cool, dry, and dark conditions, and wrapped in a suitable protective covering such as polyethylene film, which protects the sheets from ozone attack (see Note 2).

NOTE 2—Sheets of Standard Rubber stored under the above conditions remain usable for at least three years.

8.4 Standard Rubber sheets of satisfactory quality shall meet the requirements of Section A1.3.1 in Annex A1.

8.5 Standard Rubber test pieces may be used for up to three test runs per test piece (see 11.3).

9. Preparation of Rubber Test Pieces

9.1 Test pieces are cylindrical in shape with a diameter of 16 ± 0.2 mm (0.630 ± 0.008 in.) and a minimum thickness of 6 mm (0.24 in.).

9.2 They are cut from sheets of at least 6 mm (0.24 in.) thickness, using a hollow drill as described in 7.3.

9.3 Preparation of test pieces by die cutting is not permitted, but test pieces may be vulcanized or formed in an appropriate mold.

9.4 If test pieces of the required thickness are not available, the necessary thickness may be obtained by bonding a test

piece of at least 2 mm (0.08 in.) to a base piece with a hardness of at least 80 Shore A (see Test Method D 2240 and ISO 868). Care shall be taken that test pieces prepared in this manner are not abraded down to the bond line.

9.5 When testing finished products such as fabric reinforced conveyor belts, test pieces shall be prepared, if possible, from the entire product including the fabric. In this case it is also important that test pieces are not abraded down to the adhesive layer or the fabric and that only the density of the rubber layer tested for abrasion is determined.

10. Procedure

10.1 The test shall be carried out at $23 \pm 5^\circ\text{C}$ ($73 \pm 9^\circ\text{F}$) and no sooner than 16 h after vulcanization or forming of the test compounds.

10.2 The density of the rubbers to be tested shall be determined using a hydrostatic method (see Test Methods D 297 or ISO 2781).

10.3 Method A—Test Run:

10.3.1 Method A is run with a non-rotating test piece, using Standard Rubber #1 as reference.

10.3.2 Prior to each test, any debris left on the abrasive sheet from a previous abrasion test shall be removed by vigorous brushing, blowing, or suction. If necessary, the sheet may be cleaned by running a blank test with the Standard Rubber in case the sheet has been smeared by a test piece from the previous test.

10.3.3 First, at least three test runs shall be made with the Standard Rubber, followed by a maximum of ten runs (see Note 3) with one or more rubbers to be tested (test series). This shall be followed by at least another three runs with the Standard Rubber.

NOTE 3—Do not split tests of one test rubber. Run nine tests, etc., if that completes the tests for a test rubber.

10.3.4 When more than one rubber is to be tested, the test runs for each rubber shall be carried out consecutively. Only one test run per test rubber piece is permitted.

10.3.5 At least three test pieces and, for referee purposes, ten test pieces shall be run. The results shall be expressed as the mean value.

10.3.6 The test pieces shall be weighed to the nearest 1 mg and firmly fixed into the holder so that it protrudes 2.0 ± 0.2 mm (0.08 ± 0.008 in.) from the opening of the holder. Turn the vacuum on if it is provided. The swivel arm is moved into starting position and the automatic test run is started (see Note 4).

NOTE 4—A preparatory run to hollow-grind the test piece is not necessary.

10.3.7 There shall be no vibration in the test piece holder during the run. After completing an abrasion path of 40 m (131.2 ft), the test piece shall automatically disengage from the abrasive sheet.

10.3.8 The test piece is reweighed to the nearest 1 mg. Test pieces that have heated up during testing shall be conditioned to room temperature prior to weighing. Any loose material shall be removed from the test piece prior to weighing.

10.3.9 If there is a considerable loss in mass (400 mg or more per 40 m [131.2 ft] abrasion path), the test may be run by

¹⁰ Standard Rubber #1 sheets can be obtained from the following sources: CaliTek, Div. of SATEC, P.O. Box 2347, Review, MI 48192 under Item No. H04.6102.050; Bundesanstalt für Materialforschung und Prüfung (BAM), Unter den Eichen 87, Postfach POB, D 12200 Berlin, Germany; Laboratoire de Recherches et de Contrôle du Caoutchouc et des Plastiques (LRCCP), 60 Rue Auber, F94408 Vitry Sur Seine, France. Standard rubber #2 sheets would normally be prepared by the user. Users who do not have the facilities to do so may request it from Rapra Technology Ltd., Shawbury, Shrewsbury, Shropshire, SY4 4NR, UK.

stopping the abrasion drum approximately halfway through the test, readjusting the test piece to protrude 2.0 ± 0.2 mm (0.08 ± 0.008 in.) from the opening of the holder and then complete the run. Care shall be taken that the test piece does not abrade to a thickness of less than 5 mm (0.2 in.).

10.3.10 If very high mass losses are encountered (600 mg or more per 40 m [131.2 ft] abrasion path), it may be necessary to terminate the test after an abrasion path of 20 m (65.6 ft). This shall be noted in the test report and the volume loss reported for an abrasion distance of 40 m (131.2 ft) by multiplying the value by two.

10.4 Method B—Test Run:

10.4.1 Method B is run with a rotating test piece. This applies to the test rubber as well as the Standard Rubber. Standard Rubber #1 is used as reference.

10.4.2 All other test conditions are the same as described in 10.3.

10.5 Method C—Test Run:

10.5.1 Method C is run with a non-rotating test piece. This applies to the test rubber as well as the Standard Rubber. Standard Rubber #2 is used as reference.

10.5.2 All other test conditions are the same as described in 10.3.

10.6 Method D—Test Run:

10.6.1 Method D is run with a rotating test piece. This applies to the test rubber as well as the Standard Rubber. Standard Rubber #2 is used as reference.

10.6.2 All other test conditions are the same as described in 10.3.

11. Determination of Abrasiveness of the Abrasive Sheet

11.1 The abrasiveness, S , of the sheet used for the test (expressed as mass loss in mg) shall be determined with the aid of the Standard Rubber #1 in at least three, or, for referee purposes, at least five test runs, both before and after each test series. The test procedure described in 10.3 shall be followed (Method A, non-rotating test piece).

11.2 The abrasiveness is reported as the mean value of the individual mass losses before and after each test series.

11.3 Up to three runs may be carried out with the same test piece of Standard Rubber, making certain that the test piece is placed into the holder the same way each time.

11.4 For test rubbers that have a tendency to smear, it may be necessary to determine the abrasiveness after each test run.

12. Calculation of Test Results

12.1 Calculation of Abrasion Loss—Method A:

12.1.1 Calculate the abrasion loss, A_A , the loss in mass (mean value of 3 to 10 single tests) shall be converted into volume loss using the density (Volume loss equal mass loss divided by density.) of the test rubber (see Note 5). The volume loss is then corrected by using the ratio $\frac{S_O}{S}$ where S_O is the “nominal abrasiveness” of the abrasive sheet and S that of the abrasive sheet used for the test. See Eq 1.

$$A_A = \frac{\Delta m_t \cdot S_O}{d_t \cdot S} \quad (1)$$

where:

A_A = abrasion loss in mm^3 (non-rotating test piece),
 Δm_t = mass loss of the test piece in mg,
 d_t = density of the test rubber in mg/m^3 ,
 S_O = “normal abrasiveness” = 200 mg, and
 S = abrasiveness in mg.

NOTE 5—The volume loss of non-porous test pieces may also be determined by forced immersion in a buoyant medium, such as water, before and after the test run, instead of weighing the loss in mass and converting this from the density. The volume for the test piece is then obtained by weighing the displaced mass of the buoyant medium.

12.2 Calculation of Abrasion Resistance Index—Method A:

12.2.1 To calculate the abrasion resistance index, ARI_A , the loss in mass (mean value of 3 to 10 single tests) shall be converted into volume loss using the density of the test rubber (see Note 5). The ratio of the volume loss of Standard Rubber #1 to that of the test rubber is then expressed in percent, as shown in Eq 2.

$$ARI_A = \frac{\Delta m_1 \cdot d_t}{\Delta m_t \cdot d_1} \cdot 100 \quad (2)$$

where:

ARI_A = abrasion resistance index in percent (non-rotating test piece),
 Δm_1 = mass loss of the Standard Rubber #1 test piece in mg,
 d_1 = density of Standard Rubber #1 in mg/m^3 ,
 Δm_t = mass loss of the test rubber piece in mg, and
 d_t = density of the test rubber in mg/m^3 .

12.3 Calculation of Abrasion Resistance Index—Method B:

12.3.1 The abrasion resistance index, ARI_B , is calculated as described in 12.2.1 using Eq 3:

$$ARI_B = \frac{\Delta m_1 \cdot d_t}{\Delta m_t \cdot d_1} \cdot 100 \quad (3)$$

where:

ARI_B = abrasion resistance index in percent (rotating test piece),
 Δm_1 = mass loss of the Standard Rubber #1 test piece in mg,
 d_1 = density of Standard Rubber #1 in mg/m^3 ,
 Δm_t = mass loss of the test rubber piece in mg, and
 d_t = density of the test rubber in mg/m^3 .

12.4 Calculation of Abrasion Resistance Index—Method C:

12.4.1 The abrasion resistance index, ARI_C , is calculated as described in 12.2.1 using Eq 4, except that Standard Rubber #2 is used instead of Standard Rubber #1.

$$ARI_C = \frac{\Delta m_2 \cdot d_t}{\Delta m_t \cdot d_2} \cdot 100 \quad (4)$$

where:

ARI_C = abrasion resistance index in percent (non-rotating test piece),
 Δm_2 = mass loss of the Standard Rubber #2 test piece in mg, and
 d_2 = density of Standard Rubber #2 in mg/m^3 ,

12.5 Calculation of Abrasion Resistance Index—Method D:

12.5.1 The abrasion resistance index, ARI_D , is calculated as described in 12.2.1 using Eq 5, except that Standard Rubber #2 is used instead of Standard Rubber #1.

$$ARI_D = \frac{\Delta m_2 \cdot d_1}{\Delta m_1 \cdot d_2} \cdot 100 \quad (5)$$

where:

- ARI_D = abrasion resistance index in percent (rotating test piece),
- Δm_2 = mass loss of the Standard Rubber #2 test piece in mg, and
- d_2 = density of Standard Rubber #2 in mg/m³,

13. Test Report

13.1 Report the following information:

- 13.1.1 Type and identification of the product under test,
- 13.1.2 Date and temperature of testing,
- 13.1.3 Rubber compound details, if available (rubber type, vulcanization temperature and time),
- 13.1.4 Density of the test rubbers,
- 13.1.5 Method of test piece preparation (cut or molded),
- 13.1.6 Test method used: Method A, B, C or D,
- 13.1.7 The mean value of either the abrasion loss in mm³ or the abrasion resistance index in percent,
- 13.1.8 The standard deviation of the test result (optional) and
- 13.1.9 Any deviations from standard test methods, especially if the length of the abrasion path was reduced from the specified 40 m (131.2 ft) to 20 m (65.6 ft).

14. Precision and Bias

14.1 The precision and Bias section deals with test results of Methods A, C, and D obtained in an international interlaboratory program organized in accordance with ISO 5725¹¹. This section has been prepared in accordance with Practice D 4483, which is equivalent to ISO 5725. Refer to this practice for terminology and other statistical calculation details.

14.2 The precision results in this section give an estimate of the precision of Methods A, C, and D using the materials of the particular interlaboratory test program as described below. The precision parameters should not be used for acceptance or rejection testing of any group of materials without documentation that the parameters are applicable to the group of materials and the specific testing protocols of the test method.

Abrasion tests were conducted for each rubber in triplicate on each of two days, separated by three to four days. A test result was reported as the mean of three individual test runs (abrasion loss in mm³).

14.3 A Type 1 interlaboratory test program was conducted in 1986 with 16 participating laboratories, using five different vulcanized rubbers at different abrasion levels. The vulcanized rubbers were distributed in sheet form by one laboratory, and test pieces were cut from these sheets by each of the participating laboratories.

14.4 The precision is given in terms of S_r ; r , (r), SR , R , and (R) for the measured abrasion loss values.

14.5 The precision of the test method may be expressed in the format of the following statements which use an “appropriate value” of r , R , (r), or (R), that is, that value to be used in decisions about test results obtained with this test method. The appropriate value is that value of r or R associated with the mean level in Tables 1-3 closest to the mean level under consideration (at any given time, for any given material) in routine testing operations.

14.6 *Repeatability*—The repeatability, r , of this test method has been established as the appropriate value tabulated in Tables 1-3. Two single test results obtained under normal test method procedures that differ by more than this tabulated r (for any given level) must be considered as derived from different or nonidentical sample populations.

14.7 *Reproducibility*—The reproducibility, R , of this test method has been established as the appropriate value tabulated in Tables 1-3. Two single test results obtained in two different laboratories under normal test method procedures that differ by more than the tabulated R (for any given value) must be considered to have come from different or nonidentical sample populations.

14.8 Repeatability and reproducibility expressed as percent of the mean level (r) and (R), have equivalent application statements as above for r and R . For (r) and (R) statements, the difference in the two single test results is expressed as a percent of the arithmetic mean of the two-test results.

14.9 In test method terminology, bias is the difference between an average test value and the reference (or true) test property value. Reference values do not exist for this test method since the values of abrasion loss are exclusively defined by this test method. Bias, therefore, cannot be determined.

¹¹ Supporting data have been filed at ASTM Headquarters and may be obtained by requesting Research Report RR: D11-1079.

TABLE 1 Type 1 Precision (Method A: Non-Rotating Test Piece)

Test Rubber Compound	Property Mean Abrasion Loss A (mm ³)	Within Laboratory			Between Laboratory		
		S_r	r	(r)	S_R	R	(R)
A (NR/BR)	68	2.3	6.5	9.6	6.6	18.8	27.6
B (NR/SBR)	106	3.8	10.8	10.2	7.6	21.4	20.2
C (NR)	160	8.2	23.2	14.5	10.7	30.4	19.0
D (IIR)	257	10.7	30.2	11.8	20.3	57.5	22.4
E (EPDM)	345	14.1	39.8	11.5	29.3	83.0	24.1

NOTE 1— S_r = repeatability standard deviation in measurement units; r = repeatability = $2.83 \times S_r$ (in measurement units); (r) = repeatability in percent of the mean; S_R = reproducibility standard deviation in measurement units; R = reproducibility = $2.83 \times S_r$ (in measurement units); and (R) = reproducibility in percent of the mean.

TABLE 2 Type 1 Precision (Method C: Non-Rotating Test Piece)

Test Rubber Compound	Property Mean Abrasion Loss <i>A</i> (mm ³)	Within Laboratory			Between Laboratory		
		<i>S_r</i>	<i>r</i>	(<i>r</i>)	<i>S_R</i>	<i>R</i>	(<i>R</i>)
A (NR/BR)	157	10.9	30.8	19.6	21.1	59.6	38.0
B (NR/SBR)	102	5.3	15.0	14.7	6.7	19.1	18.7
C (NR)	67	3.2	9.1	13.6	4.8	13.6	20.3
D (IIR)	43	2.8	7.9	18.4	3.6	10.2	23.7
E (EPDM)	32	1.3	3.8	11.9	2.5	7.2	22.5

NOTE 1—*S_r* = repeatability standard deviation in measurement units; *r* = repeatability = $2.83 \times S_r$ (in measurement units); (*r*) = repeatability in percent of the mean; *S_R* = reproducibility standard deviation in measurement units; *R* = reproducibility = $2.83 \times S_r$ (in measurement units); and (*R*) = reproducibility in percent of the mean.

TABLE 3 Type 1 Precision (Method D: Rotating Test Piece)

Test Rubber Compound	Property Mean Abrasion Loss <i>A</i> (mm ³)	Within Laboratory			Between Laboratory		
		<i>S_r</i>	<i>r</i>	(<i>r</i>)	<i>S_R</i>	<i>R</i>	(<i>R</i>)
A (NR/BR)	144	7.1	20.2	14.0	16.2	45.8	31.8
B (NR/SBR)	101	3.4	9.6	9.5	5.6	15.9	15.7
C (NR)	71	2.5	7.0	9.9	3.9	11.0	15.5
D (IIR)	43	1.2	3.4	7.9	1.9	5.3	12.3
E (EPDM)	34	1.2	3.3	9.7	2.5	7.2	21.2

NOTE 1—*S_r* = repeatability standard deviation in measurement units; *r* = repeatability = $2.83 \times S_r$ (in measurement units); (*r*) = repeatability in percent of the mean; *S_R* = reproducibility standard deviation in measurement units; *R* = reproducibility = $2.83 \times S_r$ (in measurement units); and (*R*) = reproducibility in percent of the mean.

ANNEX

(Mandatory Information)

A1. STANDARD RUBBERS FORMULA, MIXING, VULCANIZATION AND COMPLIANCE TESTING

A1.1 Preparation of Standard Rubber #1 for Method A and Method B

A1.1.1 The formula for Standard Rubber #1 is given in Table A1.1.

A1.1.2 Mixing:

A1.1.2.1 The following procedure is recommended in mixing the Standard Rubber:

NOTE A1.1—Other mixing procedures may be employed provided they yield good dispersion of the ingredients and produce a Standard Rubber in compliance with requirements set forth in Section A1.3.1.

A1.1.2.1.1 An internal mixer with a capacity to accommodate batch sizes of 3000 to 4000 g (6.6 to 8.8 lbs) has been found suitable to produce a Standard Rubber of acceptable quality.

A1.1.2.1.2 The internal mixer typically has a chamber volume of 4.6 I (measured with wheat grain) and is charged with 2000 g of natural rubber, bringing the fill factor of the finished compound to $65 \pm 5\%$. Mixing is carried out at a rotor speed of about 0.080 rad/s (30 rpm), with full cooling turned on and following the procedure outlined in Table A1.2.

A1.1.2.1.3 After dropping the stock from the internal mixer, it is homogenized on a two roll rubber mill at a nip setting of 0.5 mm (0.02 in.) and a surface temperature of $50 \pm 5^\circ\text{C}$ ($122 \pm 9^\circ\text{F}$), by making about four $\frac{3}{4}$ cuts from alternate end of the roll and crossblending for about 5 min. The rolled sheet is then passed endwise through the nip until it is sheeted from the mill

Ingredients	Parts by Mass
Natural rubber, SMR L	100.0
2,2' Dibenzothiazyl disulfide ^A	1.8
N-Isopropyl-N'-phenyl-p-phenylene diamine ^B	1.0
Zinc oxide, ^C ISO 9298, Class B4c ^D	50.0
N 330 carbon black ^E	36.0
Sulfur	2.5
TOTAL	191.3

NOTE—If optimum reproducibility is desired, the following materials shall be used:

Vulkacit DM/C^A and Vulkanox 4010 NA/LG^B from Bayer Corporation, 2603 West Market Street, Akron, OH 44313 or Bayer AG, Rubber Business Group, D 51368 Leverkusen—Bayerwerk, Germany.

^CZinkweiss G9 available from Grillo Zinkoxid GmbH, Halberstädter Strasse 15, D 38644 Goslar, Germany.

^DZinc oxide, ISO 9298, Class B4c is an indirect (French process) type with the following typical properties: 99.0 % zinc oxide, 0.25 % lead, 0.05 % cadmium, surface area 9.0 m²/g, volatile matter 0.3 %, sieve residue (45 μm) 0.05 %, acidity 0.12 g sulfuric acid/100 g, copper 0.001 %, manganese 0.001 %, acid-insoluble 0.1 % and water-soluble 0.2 %.

^ECorax N 330 from Degussa Corporation, 3500 Embassy Parkway, Akron, OH 44333 or Degussa AG, Dept. AC-KP-AT, D 50354 Hürth—Werk Kalscheuren, Germany.

at a nip setting of 5 mm (0.2 in.) after ten minutes total mixing time. Final batch temperature shall be approximately 70°C (158°F).

A1.1.2.1.4 The two mill rolls shall have a nominal diameter

TABLE A1.2 Mixing Procedure

Addition	min
Rubber	0
Ingredients A, B, C—premixed	7.5
Carbon black	11
Sulfur	14
Dump at 100 to 110°C (212 to 230°F)	18

of 250 mm (10 in.), a working width of 400 mm (16 in.), and a rotational frequency of about 0.032/0.048 rad/s (12/18 rpm), giving a friction ratio of 1:1.5.

A1.1.3 Vulcanization:

A1.1.3.1 Blanks are prepared by plying up milled sheets and weighing them to an excess mass of approximately 7 %. The blank is inserted into a mold, preheated to $150 \pm 2^\circ\text{C}$ ($302 \pm 4^\circ\text{F}$).

A1.1.3.2 The mold is placed into the press, and after applying several bumping cycles, vulcanization is carried out for 20 ± 1 min under a pressure of at least 3.5 MPa (508 psi). It is recommended that the pressure be applied slowly.

A1.1.3.3 Recommended dimensions of the vulcanized sheets are $8 \times 116 \times 182$ mm ($0.32 \times 4.57 \times 7.17$ in.), yielding approximately 60 test pieces.

A1.1.3.4 After vulcanization, sheets of the Standard Rubber shall be conditioned at ambient conditions for at least 16 h prior to use.

A1.1.3.5 The hardness in Shore A⁸ of each sheet shall be measured at a minimum of five different locations and the median reported. The mean of the median values of all sheets from one lot shall be 60 ± 3 Shore A.

A1.2 Preparation of Standard Rubber #2 for Method C and Method D

A1.2.1 The formula for Standard Rubber #2 is given in Table A1.3.

A1.2.2 Mixing and Vulcanization:

A1.2.2.1 Mixing shall be carried out with equipment and procedures described in Practice D 3182 or ISO 2393.

A1.2.2.2 Vulcanization of sheets for the preparation of test pieces shall be carried out in accordance with Practice D 3182 or ISO 2393 at $140 \pm 2^\circ\text{C}$ ($284 \pm 4^\circ\text{F}$) for 60 min.

A1.2.2.3 The dimensions of the sheets shall meet the guidelines outlined in A1.3.3.

A1.3 Compliance Testing for Mass Loss

A1.3.1 Compliance testing for mass loss of Standard Rub-

TABLE A1.3 Standard Rubber #2

Ingredients	Parts by Mass
Natural rubber, SMR 5	100.0
Stearic acid	2.0
Zinc oxide	5.0
N 330 carbon black ^A	50.0
N-Isopropyl-N'-phenyl-p-phenylene diamine	1.0
Cyclohexyl benzothiazole sulfenamide	0.5
Sulfur	2.5
TOTAL	161.0

^AFor referee purposes the current Industry Reference Black (IRB) should be used (see Classification D 1765); this may, however, generate different test results.

bers shall be conducted no sooner than 16 hours and no later than seven days after vulcanization.

A1.3.2 One sheet is selected from each lot of Standard Rubber, prepared in accordance with Sections A1.1 or A1.2. Fifteen test pieces are cut from each sheet in accordance with Section 9. If several lots are prepared under the same conditions by the same operator over a period of one or two days, one sheet shall be selected for every fifth lot.

A1.3.3 The mass losses of fifteen test pieces of a (commercial) reference material (see 8.1) are determined first. Each test piece is run three times, the median reported and the mean calculated from the fifteen median values. This mean serves as the reference value.

A1.3.4 The same procedure is repeated for the fifteen test pieces of each sheet of Standard Rubber. The difference between the mean of the reference material and the mean of each lot (sheet) of Standard Rubber shall not exceed 15 mg.

A1.3.5 All compliance testing for mass loss shall be conducted with abrasive sheets especially conditioned and reserved for this purpose. The abrasiveness of these sheets, determined as the mean of fifteen median values for the reference material, shall be between 200 and 220 mg for Standard Rubber #1, when tested in accordance with A1.3.3, using Method A (non-rotating test piece).

A1.3.6 It has been determined that Standard Rubber #2 yields an abrasion loss of about 150 mg when tested in accordance with Method D (rotating test piece).

A1.3.7 It is recommended to retain test pieces of a number of Standard Rubber sheets as references for future lots of Standard Rubber. The test pieces shall be stored as described in 8.3.

APPENDIX**(Nonmandatory Information)****X1. BACKGROUND INFORMATION**

X1.1 The method described in this test method is in substantial agreement with a current draft revision of ISO 4649:1985, Rubber—Determination of Abrasion Resistance Using a Rotating Drum Device, with the minor exception noted below. Some elements of the German Standard DIN 53516, Determination of Abrasion Resistance, for forerunner of ISO 4649, have been retained in this test method.

X1.2 This method specifies 10 N as the only force for pressing the test piece against the revolving abrasive drum (the same as in DIN 53516). ISO 4649 allows the use of an alternate force of 5 N.

The American Society for Testing and Materials takes no position respecting the validity of any patent rights asserted in connection with any item mentioned in this standard. Users of this standard are expressly advised that determination of the validity of any such patent rights, and the risk of infringement of such rights, are entirely their own responsibility.

This standard is subject to revision at any time by the responsible technical committee and must be reviewed every five years and if not revised, either reapproved or withdrawn. Your comments are invited either for revision of this standard or for additional standards and should be addressed to ASTM Headquarters. Your comments will receive careful consideration at a meeting of the responsible technical committee, which you may attend. If you feel that your comments have not received a fair hearing you should make your views known to the ASTM Committee on Standards, 100 Barr Harbor Drive, West Conshohocken, PA 19428.

This standard is copyrighted by ASTM, 100 Barr Harbor Drive, West Conshohocken, PA 19428-2959, United States. Individual reprints (single or multiple copies) of this standard may be obtained by contacting ASTM at the above address or at 610-832-9585 (phone), 610-832-9555 (fax), or service@astm.org (e-mail); or through the ASTM website (<http://www.astm.org>).