



Standard Specification for High Voltage Detectors—Part 1 Capacitive Type to be Used for Voltages Exceeding 600 Volts AC¹

This standard is issued under the fixed designation F 1796; the number immediately following the designation indicates the year of original adoption or, in the case of revision, the year of last revision. A number in parentheses indicates the year of last reapproval. A superscript epsilon (ϵ) indicates an editorial change since the last revision or reapproval.

^{ε1} NOTE—Editorial corrections were made to 10.3.17 in February 1998.

1. Scope

1.1 This specification covers portable, live-line tool-supported, direct-contact type capacitive voltage detectors to be used on electrical systems both indoors and outdoors for ac voltages from 600 V to 800 kV with frequency of 60 Hz. The function of the voltage detector is limited to the detection of the presence or absence of nominal operating voltage.

1.1.1 This specification is not applicable to other types of voltage detectors.

1.2 The use and maintenance of these high voltage detectors and any necessary insulated tool handles are beyond the scope of this specification.

1.3 *This standard does not purport to address all of the safety concerns, if any, associated with its use. It is the responsibility of the user of this standard to establish appropriate safety and health practices and determine the applicability of regulatory limitations prior to use.*

NOTE 1—Except where specified, all voltage defined in this specification refer to phase-to-phase voltage in a three-phase system. Voltage detectors covered by this specification may be used in other than three-phase systems, but the applicable phase-to-phase or phase-to-ground (earth) voltages shall be used to determine the operating voltage.

2. Referenced Documents

2.1 ASTM Standards:

F 819 Definitions of Terms Relating to Electrical Protective Equipment for Workers²

2.2 Other Standard:³

Fed/OSHA (1910, 137, 269, Subpart S)

2.3 ANSI Standard:⁴

ANSI C84.1 Voltage Ratings for Electric Power Systems and Equipment

2.4 IEEE Standards:⁵

IEEE 516 Guide for Maintenance Methods on Energized Power Lines

IEEE 4 High Voltage Testing Techniques^f

2.5 IEC Standard:⁶

IEC 1243-1 First Addition 1993-11

3. Terminology

3.1 Definitions:

3.1.1 *capacitive voltage detector*—a device that relies on current passing through stray capacitance to ground.

3.1.2 *clear indication*—a specific condition that detects and indicates the voltage state at the contact electrode.

3.1.3 *clear perception*—the ability by the user to determine that the voltage detector is in its operating position.

3.1.4 *contact electrode*—the bare conductive part of the conductive element that establishes the electrical connection to the component to be tested.

3.1.5 *indicator*—part of the voltage detector that indicates the presence or absence of the operating voltage at the contact electrode.

3.1.6 *indoor type*—a detector designed for use in dry conditions, normally indoors.

3.1.7 *interference field*—electrical field affecting the indication.

3.1.8 *interference voltage*—voltages other than the signal voltage capable of making the device operate.

3.1.9 *limit marking*—distinctive location or mark to indicate to the user the physical limit to which the detector may be inserted between live components or may touch them.

3.1.10 *nominal operating voltage*—a nominal value consistent with the latest revision of ANSI C84.1.

3.1.11 *non-contact proximity detector*—a device that relies on current passing through stray capacitance to ground without making direct contact with the component to be tested.

¹ This specification is under the jurisdiction of ASTM Committee F-18 on Electrical Protective Equipment for Workers and is the direct responsibility of Subcommittee F18.35 on Tools and Equipment.

Current edition approved April 10, 1997. Published December 1997.

² *Annual Book of ASTM Standards*, Vol 10.03.

³ Available from the Superintendent of Documents, U.S. Government Printing Office, P.O. Box 37082, Washington, DC 20013-7082.

⁴ Available from American National Standards Institute, 11 West 42nd St., 13th Floor, New York, NY 10036.

⁵ Available from the Institute of Electrical and Electronics Engineers, Inc., 345 East 47th St., New York, NY 10017.

⁶ Available from the International Electrotechnical Commission, (IEC) Sales Department, Case Postale 131, 3 rue de Varembé, CH-1211, Geneva 20, Switzerland/Suisse. Also available in the United States from the Sales Department, American National Standards Institute, 11 West 42nd St., 13th Floor, New York, NY 10036.

3.1.12 *outdoor type*—a detector designed for use either indoors or outdoors.

3.1.13 *response time*—time delay between sudden change of the voltage state on the contact electrode and the associated clear indication.

3.1.14 *testing element*—built in or external device, by means of which the functioning of the voltage detector can be checked.

3.1.15 *threshold voltage*—minimum voltage between the line component and earth (ground) required to give a clear audible or visual indication, or both, corresponding to specific conditions as defined in corresponding test (see *clear indication* and *clear perception*).

3.1.16 *voltage detector*—a device for indicating the presence or absence of nominal design or operating voltage.

3.1.17 *voltage, nominal design*—a nominal value consistent with the latest revision of ANSI C84.1, assigned to the circuit or system for the purpose of conveniently designating its voltage class.

3.1.18 *voltage range*—value of voltage generally agreed upon by manufacturer and customer, to which certain operating specifications are referred.

3.2 Tests:

3.2.1 *acceptance test*—a test made at the option of the purchaser.

3.2.2 *design test*—a type test made on a specimen treated as representative of an industrial product. These tests will not generally be repeated in quantity production unless a change in the design is implemented.

3.2.3 *performance test*—a test performed to indicate normal operation of the instrument.

3.2.4 *routine test*—a type test made regularly on production material.

4. Significance and Use

4.1 This specification establishes requirements for the design and testing of high voltage detectors, used in the electrical power industry, to determine the presence or absence of nominal operating voltage.

5. Type of Detector

5.1 Capacitive

5.1.1 *Direct Contact*—Operates without the need for a ground lead, but requires physical contact with the component to be tested.

6. Ordering Information

6.1 Orders for high voltage detectors under this specification should include the following information:

- 6.1.1 Type,
- 6.1.2 Voltage range,
- 6.1.3 Tested to meet ASTM F 1796, and
- 6.1.4 Catalog numbers.

7. Marking

7.1 Labeling:

7.1.1 Instructions for indoor and outdoor testing use and maintenance of the voltage detectors shall be included with each unit. Whenever practicable, instructions for use and

testing shall be printed on a permanent-type label and attached to the unit.

7.1.2 Voltage range, manufacturer and a general statement regarding any use precautions or limitations shall be permanently marked on each unit.

8. Specifications

8.1 The manufacturer shall clearly specify the limits of performance of each voltage detector within the instructions as follows:

- 8.1.1 Operating voltage range or ranges,
- 8.1.2 Operating temperature range,
- 8.1.3 Operating humidity range,
- 8.1.4 Storage temperature range,
- 8.1.5 Storage humidity range, and
- 8.1.6 Any limitations in use.

9. Workmanship, Finish, and Appearance

9.1 Workmanship and finish shall be of such quality as to ensure safe operation of the unit. Appearance shall be the prerogative of the manufacturer.

10. Testing

10.1 *General*—Tests shall be performed on a detector that has been completely assembled. Tests shall be carried out under the following ambient test conditions:

- 10.1.1 Ambient temperature 59 to 95°F.
- 10.1.2 Relative humidity 45 to 75 %.

10.2 *Methods*—Unless otherwise specified, tests shall be carried out using a 60 Hz ac power source. Tests shall be performed in dry conditions.

10.2.1 The maximum voltage level shall be reached within 10 to 20 s.

10.2.2 An acceptable tolerance of $\pm 3\%$ is allowed for all required values.

10.3 *Design Test*—A design test shall be performed each time there is any significant change in the design of the unit. At least two (2) units shall be tested to ensure that design specifications are achieved.

10.3.1 *Voltage*—Each unit shall be subjected to the voltage necessary to verify the unit's threshold voltage. The threshold voltage V_t shall satisfy the following relationship $\pm 10\%$:

$$\text{Threshold voltage} = 0.3 \text{ to } 0.45 \times \text{minimum nameplate voltage} \quad (1)$$

10.3.2 *Temperature Dependence of the Indication*—The detector shall operate correctly in the temperature range of the climatic category according to Table 1. The threshold voltage shall not vary by more than $\pm 10\%$, with respect to the threshold voltage measured when tested at the minimum and maximum temperature. The detector shall be subjected to the maximum and minimum temperature extremes for 24 h and immediately subjected to a threshold voltage test. The threshold voltage is not to deviate $\pm 10\%$ from the previously tested

TABLE 1 Climatic categories

Temperature	
Temperature° C	°F
-25 to +55	-13 to +131

and recorded test report when conducted under the standard atmospheric conditions as stated in 3.2.1.

10.3.3 *Low Temperature Impact*—The procedure outlined in 10.3.4 shall be followed after exposure to $-25^{\circ}\text{C}/-13^{\circ}\text{F}$ for 24 h.

10.3.4 *Drop/Impact*—The test surface shall be concrete or steel and smooth, hard and unpliable. The height of the fall shall be 3 ft. The unit shall be dropped twice: once in the horizontal position and once in the vertical. The vertical drop shall be made on the contact electrode if present. It is acceptable if the contact electrode bends, as long as the unit continues to operate. The unit shall be considered to have passed the test if there is no significant mechanical damage and the unit meets the requirements of 10.6.

10.3.5 *Humidity*—The detector is to be exposed to a minimum of 96 % humidity for 24 h. A threshold voltage test as in 10.3.2 is to be conducted. The detector is considered to have passed if it meets the same criteria as outlined.

10.3.6 *Wet Test*—The units identified for “outdoor use” shall be tested using the Rain/Wet Test described in Annex A1.

10.3.7 *Battery Life Test*—For detectors equipped with internal test functions, the detector shall be submitted to a battery life test where after exposure to the standard atmosphere test conditions in 3.2.1, the self-test functions of the detector are activated and allowed to deplete the battery which was determined to be “new” and “fresh” at insertion. The detector’s self-test functions must last for 10 min of continuous use. The performance requirements are outlined in 10.6.

10.3.8 *Durability of Labeling*—The labels on the detector shall be scrubbed with a towelette soaked in water for 1 min then another towelette soaked in ethyl alcohol for another minute. The test is considered passed if the marking remains legible, the printing does not smear and the label remains attached.

10.3.9 *Vibration Resistance*—This test method is under consideration.

10.3.10 *Continuous Operation Rating*—The detector shall be placed in contact with a high voltage supply lead and subjected to maximum rated voltage for 10 min. The detector is considered to have passed the test if the indicating signals have worked continuously for the entire period and all the functions as specified in 10.6 are functioning after the voltage testing is completed.

10.3.11 *Response Time*—The test voltage applied shall be the threshold voltage plus 10 %. The test voltage shall remain ON and the detector shall be applied and removed five times. The time sequence between these periods should vary and each shall be at least 3 s long in duration. The test is considered passed if all response times are shorter than 1 s.

10.3.12 *Testing the “Self-Test” Function*—The self-test function, for detectors equipped with this feature, shall be activated according to the instructions. The visual or audible signals, or both, shall activate and shall be observed for proper functioning. This function shall be activated three times noting any changes observed in its operation. This test is considered passed if the proper indications appear each time.

10.3.13 *Acceptable Audible Indication*—The test should be

performed in an environment where background noise does not exceed 60 dBA.

10.3.13.1 The detector shall be mounted so that the sound axis is parallel to the ground at least 5.0 ft off any sound reflecting surface. The test shall be performed by applying a voltage of 10 % over the threshold voltage to the contact electrode.

10.3.13.2 The sound intensity shall be measured at 2 ft intervals at ± 15 degrees off centerline while moving away from the detector until the following audible thresholds are determined: (1) 77 dBA for detectors with intermittent signals, and (2) 80 dBA for detectors with continuous signals.

10.3.13.3 The detector is considered passed if the audible thresholds are met at distances consistent with the maximum voltage rating of the detector and OSHA minimum approach distances. These audible thresholds may be reduced by 10 dBA if the detector is equipped with a visual indication also.

10.3.14 *Acceptable Visual Indication*—The tests should be conducted in an environment with ambient light conditions ranging from 0 to 18 000 fc.

10.3.14.1 The test shall be performed by applying a minimum voltage of 10 % over the threshold voltage to the contact electrode.

10.3.14.2 Three observers shall determine that visual detection can be made throughout angles of ± 15 % off the detector centerline at distances up to and including 10 ft from the detector under test.

10.3.15 *Visual Inspection*—The detector shall be reviewed for any defects apparent in its enclosure, contact electrode, or visual and audible indicating systems. Labeling shall be inspected and any accessories shall also be visually inspected. If any defects are found, the detector is to be rejected.

10.3.16 *Method to Measure Threshold Voltage*—The detector shall be supported in a non-conductive fixture in a horizontal position. For a detector with a maximum rated voltage of 69kV and below, it will be positioned 3 ft above a conductive floor. No foreign objects shall be located between the test fixture and the floor. For detectors rated above 69kV, the height from floor dimension will be 6 ft.

10.3.16.1 The connecting cable shall be free and clear of all surrounding objects connecting to the detector on an even axis. The detector shall be tested according to its designed threshold voltage rating.

10.3.16.2 The detector is considered to have passed if it responds at the calculated threshold voltage.

10.3.17 *Interference Voltage Testing*—Refer to Fig. 1 for the test set-up for Interference Voltage Testing.

10.3.17.1 For testing opposite phase interference voltage, refer to the test set-up shown in Fig. 2.

(1) The test voltage is 0.6 times the voltage rating of the detector, or the highest voltage in its voltage range. The test shall be performed at 60Hz.

(2) The detector passes the test if it does not indicate that voltage is present.

10.3.17.2 For testing same phase interference, refer to the test set-up shown in Fig. 3.

(1) The test voltage shall be 0.4 times the voltage of the detector, or, if set for a voltage range, the test shall be

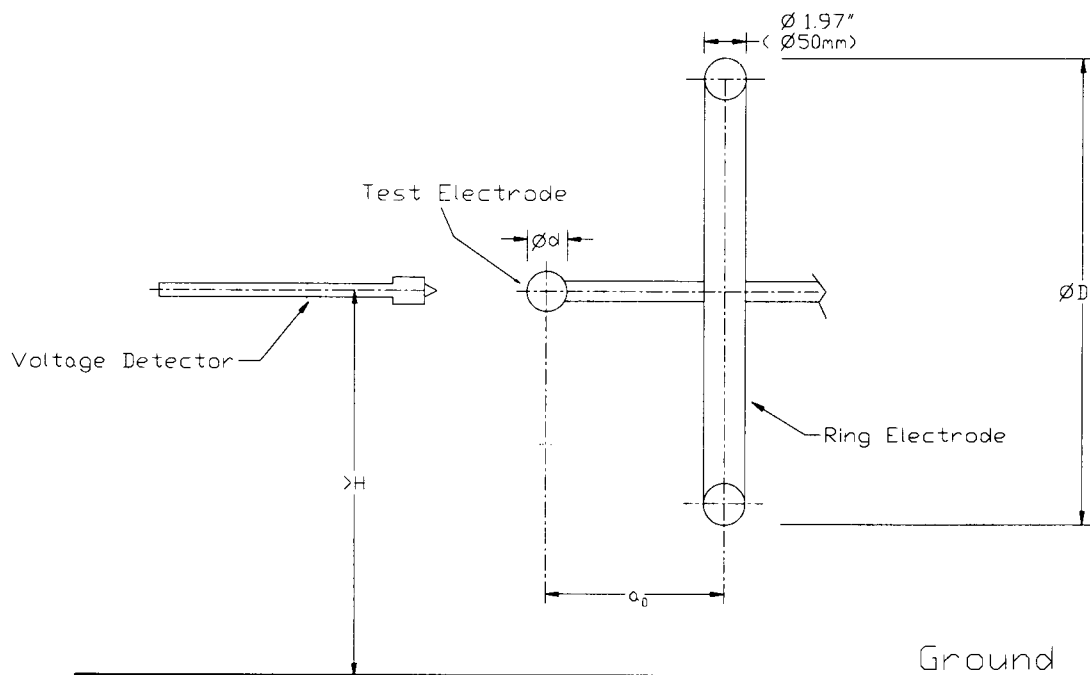

Un - Nominal Voltage (KV)	Electrode Separation distance a_0 Inches (mm)	H Inches (mm)	D Ring Diameter Inches (mm)	d Sphere Diameter Inches (mm)
1 < Un ≤ 12 12 < Un ≤ 24 24 < Un ≤ 52	12 (300)	> 59 > (1500)	Ø 22 (550)	Ø 2 (60)
52 < Un ≤ 170 170 < Un ≤ 420	39 (1000)	> 98 > (2500)	Ø 41 (1050)	Ø 4 (100)

FIG. 1 Test Fixture Details for Interference Voltage Testing

performed at both the lower and the higher voltages. The tests shall also be performed at the lower and higher nominal frequency range.

(2) The detector passes the test if it indicates that voltage is present.

10.3.18 *Leakage Current Testing*—The detector is to be considered conductive, therefore no testing is required.

10.3.19 *Dielectric Testing of Detector Housing*—The detector is to be considered conductive, therefore no testing is required.

10.3.20 *Wet Testing*:

10.4 *Routine Performance Requirement*—A routine voltage test shall be performed on each completed unit of a production run to ensure that each unit is performing according to operational specifications.

10.4.1 Voltage test as referenced in 10.3.1.

10.4.2 Testing the self-test function as referenced in 10.3.12.

10.4.3 Visual inspection as referenced in 10.3.15.

10.5 *Acceptance Test*—As defined, an acceptance test is only performed at the request of the customer in compliance with specific requirements.

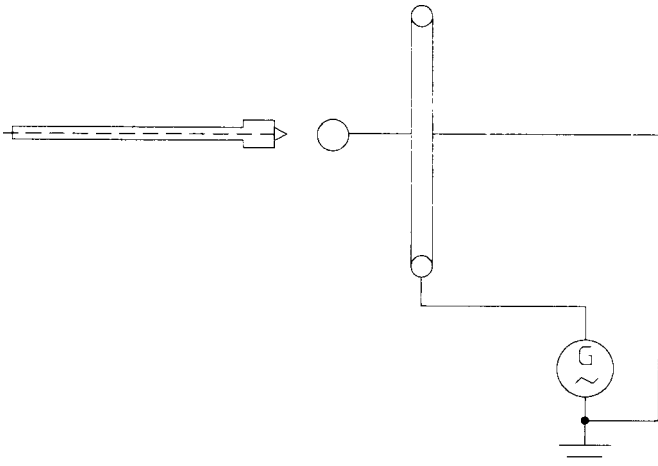

FIG. 2 Influence of Opposite Phase Interference Voltage

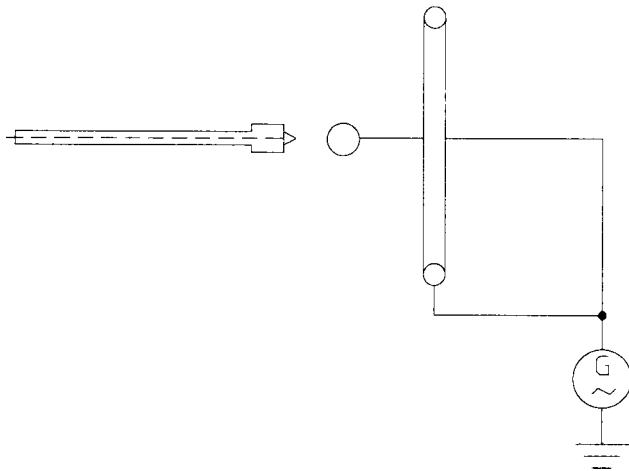

FIG. 3 Influence of In-Phase Interference Voltage

10.6 Performance:

10.6.1 *Indication*—Visible or audible, or both, indication of which clearly indicates the presence of nominal operating

voltage within the specified voltage range. These indications shall be clearly detectable under light and noise conditions as outlined in 10.3.13 and 10.3.14.

10.6.2 *Low Battery*—Low battery conditions shall be clearly indicated as described in the instructions. The detector shall not be used until the battery has been replaced and proper operation has been verified.

10.6.3 *Detector Check*—If a self-checking system can be incorporated into the overall design of the detector to allow internal functions to operate before and after each use, it will test all visual and audible indications and all normal operating functions. This test does not test for line functions.

11. Inspection

11.1 Inspection of the device shall be agreed upon between the purchaser and the supplier as part of the purchase contract.

12. Rejection

12.1 Devices that fail to conform to the requirements of this specification may be rejected. Rejection should be reported to the producer or supplier promptly and in writing. In case of dissatisfaction with the rejection, the producer or supplier may make a claim for another approval.

13. Certification

13.1 When specified in the purchase order or contract, the purchaser shall be furnished certification that samples representing each lot have been either tested or inspected as directed in this specification and the requirements have been met. When specified in the purchase order or contract, a report of the test results shall be furnished.

14. Precision and Bias

14.1 Each testing agency has the responsibility of judging the acceptability of its own results. The precision of the results is a function of the procedures and facilities utilized, as well as, compliance to the recommended industry state-of-the-art practices. Reproducible analysis determinations by different users can be achieved only with identical facilities and trained conscientious personnel.

ANNEX

(Mandatory Information)

A1. RAIN/WET TEST FOR HIGH VOLTAGE DETECTORS

A1.1 The detectors are to be considered conductive and not to be used in the rain. The most significant testing that is required is to determine if the detector's threshold voltage (TV) changes due to wetting of the detector. The following test procedure outlines this test.

A1.2 Test:

A1.2.1 The detector is to be mounted in the test fixture as described for measurement of TV, and tested. The voltage supply is then shut off and the detector is wetted by spraying with water from a spray bottle until surface beading begins to

run. Do not allow the beading water to form a continuous line. The voltage is then reapplied. The TV is measured and the detector is considered to have passed if the TV did not vary more than $\pm 3\%$.

A1.2.2 The same test is conducted with the detector in a 45 degree position.

A1.2.3 The same set of tests are performed with the detector after it has been cleaned with ethyl alcohol and dried. The same test results apply to this test.

**NOTICE: This standard has either been superseded and replaced by a new version or discontinued.
Contact ASTM International (www.astm.org) for the latest information.**

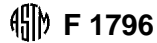

The American Society for Testing and Materials takes no position respecting the validity of any patent rights asserted in connection with any item mentioned in this standard. Users of this standard are expressly advised that determination of the validity of any such patent rights, and the risk of infringement of such rights, are entirely their own responsibility.

This standard is subject to revision at any time by the responsible technical committee and must be reviewed every five years and if not revised, either reapproved or withdrawn. Your comments are invited either for revision of this standard or for additional standards and should be addressed to ASTM Headquarters. Your comments will receive careful consideration at a meeting of the responsible technical committee, which you may attend. If you feel that your comments have not received a fair hearing you should make your views known to the ASTM Committee on Standards, at the address shown below.

This standard is copyrighted by ASTM, 100 Barr Harbor Drive, PO Box C700, West Conshohocken, PA 19428-2959, United States. Individual reprints (single or multiple copies) of this standard may be obtained by contacting ASTM at the above address or at 610-832-9585 (phone), 610-832-9555 (fax), or service@astm.org (e-mail); or through the ASTM website (www.astm.org).