



Designation: D 4129 – 98

Standard Test Method for Total and Organic Carbon in Water by High Temperature Oxidation and by Coulometric Detection¹

This standard is issued under the fixed designation D 4129; the number immediately following the designation indicates the year of original adoption or, in the case of revision, the year of last revision. A number in parentheses indicates the year of last reapproval. A superscript epsilon (ϵ) indicates an editorial change since the last revision or reapproval.

1. Scope

1.1 This test method covers the determination of total and organic carbon in water and waste water, including brackish waters and brines in the range from 2 to 20 000 mg/L. This test method has the advantages of a wide range of concentration which may be determined without sample dilution and the provision for boat or capillary introduction of samples containing sediments and particulate matter where syringe injection is inappropriate.

1.2 This procedure is applicable only to that carbonaceous matter in the sample that can be introduced into the reaction zone. When syringe injection is used to introduce samples into the combustion zone, the syringe needle opening size limits the maximum size of particles that can be present in samples. Sludge and sediment samples must be homogenized prior to sampling with a micropipetor or other appropriate sampler and ladle introduction into the combustion zone is required.

1.3 The precision and bias information reported in this test method was obtained in collaborative testing that included waters of the following types: distilled, deionized, potable, natural, brine, municipal and industrial waste, and water derived from oil shale retorting. Since the precision and bias information reported may not apply to waters of all matrices, it is the user's responsibility to ensure the validity of this test method on samples of other matrices.

1.4 *This standard does not purport to address all of the safety concerns, if any, associated with its use. It is the responsibility of the user of this standard to establish appropriate safety and health practices and determine the applicability of regulatory limitations prior to use.* For specific precautionary statements, see 9.1 and 10.2.1.

2. Referenced Documents

2.1 ASTM Standards:

¹ This test method is under the jurisdiction of ASTM Committee D-19 on Water and is the direct responsibility of Subcommittee D19.06 on Methods for Analysis for Organic Substances in Water.

Current edition approved Dec. 10, 1998. Published March 1999. Originally published as D 4129 – 82. Last previous edition D 4129 – 88 (1993).

D 513 Test Methods for Total and Dissolved Carbon Dioxide in Water²

D 1129 Terminology Relating to Water²

D 1193 Specification for Reagent Water²

D 3370 Practices for Sampling Water from Closed Conduits²

D 3856 Guide for Good Laboratory Practices in Laboratories Engaged in the Sampling and Analysis of Water²

D 4210 Practice for Interlaboratory Quality Control Procedures and a Discussion on Reporting Low-Level Data²

D 5789 Practice for Writing Quality Control Specifications for Standard Test Methods for Organic Constituents²

3. Terminology

3.1 *Definitions*—For definitions of terms used in this test method, refer to Terminology D 1129.

4. Summary of Test Method

4.1 The sample is homogenized or diluted, or both, as necessary. If the sample does not contain suspended particles or high-salt level a 0.200-mL portion is injected into the reaction zone. For samples containing solids or high salt levels, portions are placed in combustion boats containing tungsten trioxide (WO₃) or quartz capillaries and introduced into the reaction zone using a ladle. In the reaction zone the heat, oxidation catalyst and oxygen atmosphere convert carbonaceous matter to carbon dioxide (CO₂). The oxygen gas stream sweeps the gaseous reaction products through a series of scrubbers for potentially interfering gases and then to the absorption/titration cell. The CO₂ is determined by automatic coulometric titration. Calibration by testing known carbon content standards is not required, however, standards are analyzed periodically to confirm proper operation.

4.2 Carbon dioxide is liberated from carbonates as well as from organic matter under the reaction conditions. Organic carbon is determined by difference between the total carbon and the inorganic carbon determined separately or by acidifying a portion of the sample to a pH of 2 or less and sparging

² *Annual Book of ASTM Standards*, Vol 11.01.

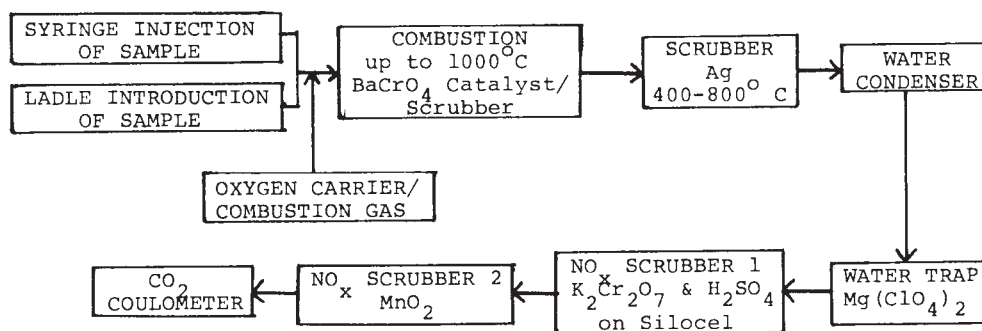

FIG. 1 Total Carbon and TOC Apparatus

with carbon dioxide-free gas to remove carbonates, bicarbonates, and dissolved carbon dioxide prior to total carbon determination. To determine organic carbon by difference the inorganic carbon is determined by acid release of carbon dioxide from a portion of the sample or other methods as given in Test Methods D 513. For discussion of the limitations and guidelines for the use of the sparge technique see 5.4 and the paper by Van Hall.³

4.3 Because of the various properties of carbon-containing compounds in water, any preliminary treatment of a sample prior to injection dictates a definition of the carbon measured. Filtration of the sample prior to injection will limit the carbon measured to dissolved carbonates and dissolved organic matter. Homogenizing permits determination of the carbon in insoluble carbonates and insoluble organic materials.

5. Significance and Use

5.1 This test method is necessary because of the need for rapid reliable tests for carbonaceous material in waters and sediments.

5.2 It is used for determining the concentration of organic carbon in water that comes from a variety of natural, domestic, and industrial sources. Typically, these measurements are used to monitor organic pollutants in domestic and industrial waste water.

5.3 When a sample is homogenized so that particulate, immiscible phases, and dissolved carbon from both organic and inorganic sources is determined, the measurement is called total carbon (TC). When inorganic carbon response is eliminated by removing the dissolved CO₂ prior to the analysis or the dissolved CO₂ concentration subtracted from the total carbon concentration, the measurement is called total organic carbon (TOC). When particulates and immiscible phases are removed prior to analysis the measurement is called dissolved carbon (DC), or dissolved organic carbon (DOC) if inorganic carbon response has been eliminated.

5.4 Homogenizing or sparging of a sample, or both, may cause loss of volatile organics, thus yielding a negative error. The extent and significance of such losses must be evaluated on an individual basis. If significant quantities of volatile carbonaceous materials are present or may be present in samples

organic carbon should be determined by the difference between the total carbon and the inorganic carbon concentrations. When organic carbon determined both by difference and by sparging agree it is acceptable to determine organic carbon by sparging for similar samples.

5.5 The relationship of TOC to other water quality parameters such as COD and BOD is described in the literature.⁴

6. Interferences

6.1 Any acidic or basic gas formed in the oxidation of the sample and not removed by the scrubbers will interfere with the test. Potentially interfering gases that are removed by the scrubbers include hydrogen sulfide (H₂S), hydrogen chloride (HCl), hydrogen bromide (HBr), hydrogen iodide (HI), sulfur dioxide (SO₂), sulfur trioxide (SO₃) free halogens, halogen oxides, and nitrogen oxides. Hydrogen fluoride (HF) may be removed by bubbling the gas stream through water in the water vapor condenser.

6.2 The capacity of the scrubbers for potentially interfering gases may vary with the type of samples being analyzed. If the scrubber capacity is exceeded it can be recognized by the titration continuing beyond the normal analysis time at a higher rate than the blank and high results for known carbon content standards as well as by appearance changes in the scrubbers. If the scrubber capacity is exceeded during an analysis the scrubbers should be replaced and the analysis repeated. Samples containing all concentrations of the potentially interfering species can be analyzed if the analyst uses great care to ensure that the scrubbers are and remain effective for his samples. The frequency of replacing the scrubbers will depend on the nature of the samples.

7. Apparatus

7.1 Apparatus for total carbon, organic carbon, and inorganic carbon determinations—combustion furnace with gas supply, gas purification train, flow control, acid reaction train, and carbon dioxide coulometer.⁵ Fig. 1 and Fig. 2 show block diagrams of the apparatus.

⁴ Handbook for Monitoring Industrial Wastewater, U.S. Environment Protection Agency, August 1973, pp. 5-10 to 5-12.

⁵ Instruments marketed by Coulometrics, Inc., a subsidiary of UIC Inc., P.O. Box 563, Joliet, IL, 60434, or an equivalent, have been found satisfactory.

³ Van Hall, C. E., Barth, D., and Stenger, V. A., "Elimination of Carbonates from Aqueous Solutions Prior to Organic Carbon Determinations," *Analytical Chemistry*, Vol 37, 1965, pp. 769-771.

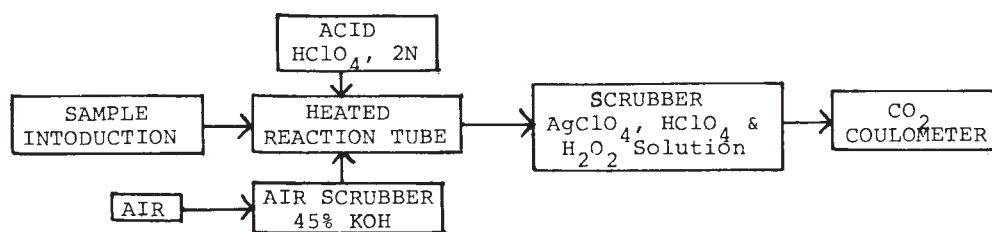

FIG. 2 CO₂ Evolution Apparatus

7.2 *Sampling Devices*—A spring-loaded .200-mL syringe⁶ (carbon analyzer syringe) having an all metal tip and a 50 mm long, 0.5-mm inside diameter needle with a square end is recommended for water samples containing little or no particulate matter.

7.3 *Homogenizing Apparatus*—A household blender with glass mixing chamber is generally satisfactory for homogenizing immiscible phases in water.

8. Reagents

8.1 *Purity of Reagents*—Reagent grade chemicals shall be used in all tests. Unless otherwise indicated, it is intended that all reagents shall conform to the specifications of the committee on Analytical Reagents of the American Chemical Society.⁷ Other grades may be used provided it is first ascertained that the reagent is of sufficiently high purity to permit its use without lessening the accuracy of the determination.

8.2 *Purity of Water*—Unless otherwise indicated, reference to water shall be understood to mean reagent water conforming to the Specification D 1193, Type II. Where specified, carbon dioxide-free water is to be prepared by boiling distilled water in a conical flask for 20 min. The boiled water is cooled in the flask stoppered with a one-hole rubber stopper fitted to a soda lime-Ascarite drying tube. For large (10 to 20 L) volumes of carbon dioxide-free water, the absorbed carbon dioxide may be removed by inserting a fritted-glass gas-dispersion tube to the bottom of the container and vigorously bubbling nitrogen through the water for at least 1 h. Carbon dioxide-free water may be stored if properly protected from atmospheric contamination.

NOTE 1—Glass containers are preferred for the storage of reagent water and most standard solutions. It is necessary to provide protection against changes in quality due to the absorption of gases or water vapor from the laboratory air. As volumes of fluid are withdrawn from the container, the replacement air should be passed through a drying tube filled with equal parts of 8 to 20-mesh soda lime, oxalic acid, and 4 to 8-mesh anhydrous calcium chloride, each product being separated from the other by a glass-wool plug.

8.3 *Gas Supply*—Use oxygen of at least 99.6 % purity.

8.4 *Scrubber Tubes and Catalyst Packings* as well as instructions for their preparation are available from the equipment manufacturer.⁸ Fig. 1 illustrates the flow diagram and names the reagents used.

8.5 *Carbon Dioxide Coulometer Reagents*—Cell solutions to absorb CO₂ from the gas stream and convert it to a titratable acid and permit 100 % efficient coulometric titration.⁸

8.6 *Acid*—Various acids may be used for acidification of samples. Hydrochloric acid is recommended. Phosphoric and sulfuric acids are suitable if they do not cause materials to precipitate from the sample. Nitric acid is not recommended because it may cause premature oxidation of organics in the sample.

8.7 *Organic Carbon Standard Solutions*—Although the method does not require sample standardization, proper operation of the instrument should be confirmed by injection of standards of similar composition and concentration to the unknown. Standards should be stable water soluble compounds such as KHP or benzoic acid of suitable purity.

9. Hazards

9.1 Injection of samples containing over 25 000 mg/L TOC or 0.5 mL water may cause explosion of the combustion tube.

10. Sampling

10.1 Collect the sample in accordance with Practices D 3370 or other applicable ASTM method(s).

10.2 *Preservation:*

10.2.1 To preserve samples for this analysis, store or ship samples in glass at or below 4°C. **Caution**—Head space in the sample bottle or freezing the sample may contribute to the loss of volatile organics from some samples.

10.3 For monitoring of waters containing solids or immiscible liquids of interest, use a mechanical homogenizer or ultrasonic disintegrator to homogenize samples.

10.4 For waste water streams where carbon concentrations are greater than the desired range of instrument operation, provide on-stream dilution of the sample if possible.

10.5 A1.1 gives additional guidelines for preparing heavily contaminated water samples when using the sparge technique.

10.6 A1.2 gives additional guidelines for samples containing solids and immiscible liquids.

⁶ Syringes manufactured by Hamilton Co., P.O. Box 10030, Reno, NV 89510, or an equivalent, have been found satisfactory for this purpose.

⁷ *Reagent Chemicals, American Chemical Society Specifications*, American Chemical Society, Washington, DC. For suggestions on the testing of reagents not listed by the American Chemical Society, see *Analar Standards for Laboratory Chemicals*, BDH Ltd., Poole, Dorset, U.K., and the *United States Pharmacopeia and National Formulary*, U.S. Pharmaceutical Convention, Inc. (USPC), Rockville, MD.

⁸ Satisfactory reagents available from Coulometrics, Inc., a subsidiary of UIC Inc., P.O. Box 563, Joliet, IL, 60434 use ethanolamine to absorb CO₂ forming hydroxyethylcarbamic acid that is titrated coulometrically using a color indicator for end-point detection.

11. Calibration and Standardization

11.1 Set up the analyzer and fill coulometer cell in accordance with the manufacturer's specifications. Adjust the gas flow to 80 to 100 mL/min. Set the readout to milligrams per litre except when other than 0.200-mL samples are used in which case set the readout to micrograms.

11.2 Analyze samples of carbon dioxide-free water as instructed in Section 12 for samples to determine the instrument blank, *B*.

11.3 Calibration is not required, however, inject appropriate standard(s) prior to and following analysis of samples to confirm proper operation. The standard concentration(s) should be approximately that of the samples to be analyzed. If the recovery of standards is unacceptable the cause of poor results should be determined and corrected. Low results suggest a leak or exhausted combustion tube packing. High results suggest contamination of the samples or exhausted scrubber or combustion tube fillings.

12. Procedure

12.1 Condition each sample to bring the homogenous carbon content within range. Although analyses of samples containing up to 20 000 mg/L TOC is possible, dilution to TOC levels below 1000 is preferable if the sample contains salts or forms a precipitate upon acidification.

12.2 See 12.3, 12.4, and 12.5 for total carbon and TOC by sparging; 12.6 applies to carbonate carbon determinations when organic carbon is to be determined by difference.

12.3 *Syringe Injection of Samples*—Rinse the syringe several times with the solution to be analyzed, then fill to precise volume (0.200 mL). Wipe off the excess from the needle tip with soft paper tissue, taking care that no lint adheres to the needle. Insert the sample syringe into the injection port, inject the sample, and reset the coulometer to zero. Leave the syringe in the holder until the analysis is completed.

12.4 *Ladle Introduction of Samples:*

12.4.1 When a micropipet can be used with the sample, place 0.200 mL of the sample into a platinum boat or a capillary tube containing approximately 20 mg of WO₃. Position the boat (capillary) in the ladle and place the ladle in the cool portion of the combustion tube through the introduction port. After closing the introduction port, allow 60 s for the oxygen gas stream to sweep out air that entered then move the ladle into the furnace.

NOTE 2—The WO₃ is used to minimize potential difficulties caused by salts in samples. Use of the WO₃ will minimize the splattering of the sample which allows salts in the sample to degrade the combustion tube. The WO₃ also helps prevent salts from reacting with CO₂ forming carbonates which then decompose slowly lengthening the analysis time and increasing the instrument blank.

12.4.2 When a precise volume (0.200 mL) of the sample cannot be obtained, weigh the sample into the combustion boat or capillary tube and introduce it into the combustion zone as described in 12.4.1.

NOTE 3—When weighing samples the size of the sample may be increased. The carbon content must not exceed 4 mg or the water content exceed 0.4 mL.

NOTE 4—The density of the sample must be known to report the results

if the result is to be given in mg/L when samples are weighed into combustion boats.

12.5 Consistent analysis times must be used for all samples and blanks. The time must be sufficient for all CO₂ to be swept from the combustion tube to the coulometer and titrated as evidenced by stable coulometer readings. The time required will depend upon the nature of the samples and is normally 3 to 7 min. High-level samples require longer analysis times than low level samples and may result in higher blank levels, especially if the samples are high in salts. If samples of a large concentration range are being analyzed care must be used when analyzing lower level samples following much higher level samples. Additional blanks must be run to confirm that the blank is reasonable and consistent.

12.6 Carbonate carbon may be determined using the methods given in Test Methods D 513 or as instructed by equipment manufacturer.

13. Calculation

13.1 Read total carbon values of 0.200-mL samples directly from the digital display. Correct these values by subtracting the blank value, *B*, obtained with carbon dioxide-free water and correct for any dilutions made to obtain original sample values.

13.2 For organic carbon values of acidified and sparged 0.200-mL samples, read the values directly from the digital display. Correct these values by subtracting the blank value *B*, and correct for any dilutions in acidifying or other steps to obtain original sample values.

13.3 For organic carbon values determined by difference the result is obtained as follows:

$$O = T - C$$

where:

O = organic carbon for original sample, mg/L

T = total carbon corrected for any blank and dilutions mg/L, and

C = carbonate carbon corrected for any blank and dilutions calculated in accordance with the instructions for the method used, mg/L.

NOTE 5—The digital display of the coulometer is set for readout in milligrams of carbon per litre for 0.200-mL samples. When other sample volumes are used the readout may be changed to compensate for the volume change or the correct value calculated using the new sample volume without changing the display units. The readout may also be set to be in micrograms of carbon.

13.4 When total carbon or organic carbon is determined by introduction in a boat, capsule or capillary tube, the concentration of carbon is determined as follows if the volume used is not 0.200 mL:

$$c = m/V \text{ or } md/W$$

where:

c = concentration of carbon, mg/L,

m = micrograms of carbon in sample, corrected for instrument blank,

V = volume of sample, mL,

d = density of sample, g/mL, and

W = weight of sample used, g.

NOTE 6—In some cases, such as for sediments, it may be desirable to

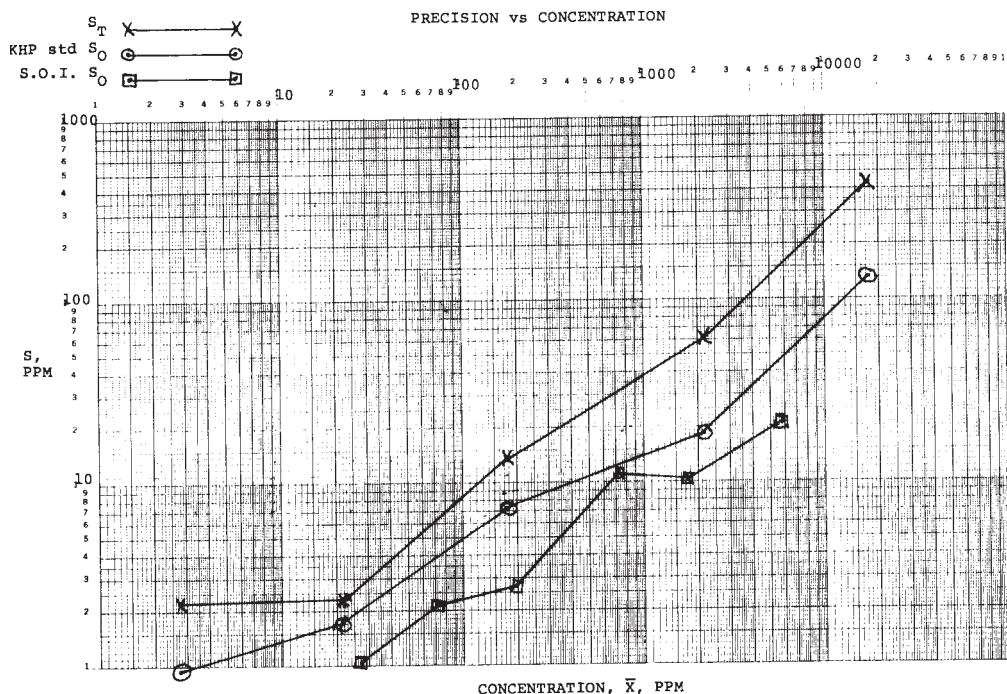

FIG. 3 Precision Versus Concentration

know the concentration per gram of sample instead of per litre, in which case the following may be used: $c = m/W \times 1000$ where c is now the concentration of carbon in milligrams per litre.

14. Report

14.1 The results may be reported in milligrams per litre or other units as desired. The units used must be clearly noted in the report.

15. Precision and Bias ⁹

15.1 The overall and single-operator precision of this test method varies with the concentration. The precision for standards and for laboratory samples of interest are shown in Fig. 3 .

15.2 The observed precision and bias for a series of potassium hydrogen phthalate in water standards were as shown in Table 1.

15.3 The recoveries from standard solutions and samples of interest were as shown in Table 2.

⁹ Supporting data are available from ASTM Headquarters. Request RR: D19-1094.

TABLE 2 Recoveries ^A

Matrix	Concentration Range, mg/L			
	22	50 +	500 +	4500 +
Deionized water, avg	98.2%	99.0%	98.2%	99.0%
S_{avg}	4.7	6.9	2.8	2.3
Sample of interest, avg	N/A	103.0	98.7	97.3
S_{avg}	N/A	10.9	1.3	5.4

^ANone of the S_{avg} are significantly different from 100 % at the 95 % confidence level.

15.4 Nine laboratories participated in the collaborative testing using syringe injection of sparged samples. Samples of interest included: distilled, deionized, municipal tap, natural, brine, waste, oil shale retort, and industrial process waters. For other matrices or other techniques (ladle introduction, TOC calculated by difference between total carbon and dissolved CO₂) the precision and accuracy may vary. It is the user's responsibility to determine the validity of the method and the resulting precision and accuracy.

15.5 The testing program required laboratories to test samples covering the full concentration range of the method, 2 to 20 000 mg TOC/L (five samples of potassium hydrogen phthalate in distilled water and three samples of interest analyzed before and after spike additions).

TABLE 1 Precision and Bias

Sample	Added Amount, mg/L	\bar{X} , mg/L	S_O , mg/L	% S_O	S_T , mg/L	% S_T	Bias, mg/L	% Bias	Significant?
102	22	21.2 ^A	1.8	8.3	2.4	11.2	-0.8	-3.6	no
103	180	178. ^A	7.3	4.1	13.5	7.6	-2.	-1.1	no
104	2200	2160. ^A	19.	0.9	61.	2.8	-40.	-1.8	yes ^B
104	18 000	17800. ^A	130.	0.7	420.	2.3	-200.	-1.1	no

^AValue after subtracting result for blank, sample 101 which had an \bar{X} of 2.7 mg/L and an S_O of 0.9 mg/L.

^BThis bias is statistically significant at the 95 % confidence level. The user of the method may not find the bias significant in his application.

NOTE 7—The full concentration range is seldom encountered in normal practice and presented some difficulties for the participants. The problems were maintaining a stable blank in going from extremely high concentrations to low concentrations and use of appropriate standards. The procedure calls for determination of the instrument blank and testing of standard(s) before running samples. When a standard appropriate for the high concentrations is tested the instrument requires some time to stabilize sufficiently for the lowest concentration samples. In normal laboratory practice the extreme concentration range is not likely to be encountered and standards can be more easily chosen and tested. The reported precision and bias may be poorer than a laboratory will achieve working in a narrower concentration range.

16. Quality Assurance/Quality Control

16.1 Minimum quality control requirements are initial demonstration of proficiency, plus analysis of method blanks, quality control samples, and recovery spikes. In addition, duplicate samples may be required for specific programs. For a general discussion of quality control and good laboratory practices, see Practices D 4210, D 5789, and Guide D 3856.

16.2 *Method Blank*—Before processing any samples, the analyst must demonstrate that all glassware and reagent interferences are under control. At least daily, or whenever a major change is made to the apparatus (change scrubber tube, etc.), analyze a method blank. The variability of the blank result shall be less than 2 mg/L.

16.3 *Initial Demonstration of Proficiency:*

16.3.1 Select a representative spike concentration of organic standard as representative as possible of the sample composition. A concentration used in the interlaboratory study is recommended. Add spike concentrate to at least seven 1-L aliquots of water, and analyze each aliquot according to the procedures in Section 12. Calculate the mean and standard deviation of these values and compare to the acceptable range of precision and bias found in Table 3.

16.3.2 This study should be repeated until the single operator precision and the mean value are within acceptable limits. Refer to Practice D 5789 to develop limits for spikes at other concentrations.

TABLE 3 Percent Recovery Limits

Spike Concentration	Proficiency Demonstration	QC Check	Recovery Spike
	Max Acceptable Standard Deviation	Acceptable Range for Mean Recovery	Acceptable Range for QC Check
2200 mg C/L	19 mg/L	1976–2424 mg/L	1817–2387 mg/L
			Acceptable Range for Recovery Spike
			1976–2024

16.4 *Ongoing Quality Control Sample*—To insure that the test method is in control for reagent water, analyze a single quality control sample containing 22 mg/L (or selected level) of the target analytes with each batch of up to 20 samples. The value obtained should be within the range listed in Table 3 before beginning the analysis of samples.

16.5 *Recovery Spikes*—To insure that the test method is in control for each sample matrix, analyze a spiked sample at least once for each matrix. If the unspiked sample was essentially free of analyte or the spike to background concentration is ten or more, the percent recovery should fall within the limits specified in Table 3. If recoveries are outside of established limits, examine the performance of the system. If calibration and quality control results are in control, the problems observed with the recovery should be noted with the results. Depending on program requirements, additional analyses may be required. Refer to Practice D 5789 for guidelines on reporting and evaluating the results.

16.6 *Duplicates*—Analysis of duplicates is recommended to assess the precision of the method on matrix samples. If a high frequency of nondetects are expected, spiked matrix duplicates should be used to assess precision. Refer to Guide D 3856 and Practice D 4210 to develop ranges and construct control charts based on these results.

17. Keywords

17.1 carbon; carbon dioxide; high temperature oxidation; inorganic carbon; organic carbon; total carbon

ANNEXES

(Mandatory Information)

A1. SAMPLE PREPARATION FOR HEAVILY CONTAMINATED WATERS

A1.1 Improper preparation of heavily contaminated water samples may yield erroneously low results. Acidification of such water can cause separation of organics that may be lost during subsequent sampling and injection. For example, an organic acid may be soluble in a high-pH water but, because of its high concentration, not soluble upon acidification. This problem can be solved by first diluting the sample and then acidifying slowly while stirring. Dilution tends to keep the organics in solution and minimizes problems if salts are present, while slow acidification of the diluted sample tends to keep the insolubles formed small in particle size and well dispersed. If the TOC concentration is not much smaller than the TC concentration, determination of TOC by difference may

be preferred over determination of TOC by use of the sparge technique.

A1.2 The procedure for acidifying and sparging samples is as follows:

A1.2.1 Blend the water sample, if necessary, to produce a homogeneous sample suitable for dilution.

A1.2.2 Dilute the blended sample sufficiently with water to improve solubility and suspension of potentially insoluble organics. **CAUTION—DO NOT REDUCE ORGANIC CARBON CONCENTRATION BELOW THE RANGE OF THE METHOD.** Determine the approximate level initially if uncertain.



A1.2.3 While stirring, acidify the diluted sample to pH 2 to 3 slowly so as to keep any particles formed small in size and well dispersed. A dilute acid may be required to accomplish this. Note the quality of acid added for later volumetric correction of results if a known sample volume is not being diluted to a known final volume.

A1.2.4 Sparge the sample to complete removal of dissolved CO₂.

A1.2.5 Blend the acidified sample, if necessary, and while stirring, take an aliquot for analysis using an appropriate syringe or micropipet.

NOTE A1.1—For some samples it has been found convenient to add sufficient alkali to cause the organic acids to redissolve. If this is done the sample should be analyzed immediately afterwards to minimize the absorption of CO₂ from the air.

A1.2.6 The blank correction for the instrument should be performed on CO₂ free water treated identically to the samples to compensate for organic contaminants in the reagents added to the samples.

A2. SAMPLE CONDITIONING FOR SUSPENDED SOLIDS AND IMMISCIBLE LIQUIDS

A2.1 If the sample is relatively homogeneous, no conditioning will be required except for possible dilution and mixing.

A2.2 Samples containing solids of no interest should be filtered prior to analysis. Sedimentation or centrifugation may also be employed for solids removal if desired.

A2.3 For laboratory analysis of samples containing immiscible liquid or solid phases of interest, homogenize the sample in a glass household-type blender or an ultrasonic disintegrator. Reproducibility of results will indicate when homogenization of the sample is complete.

The American Society for Testing and Materials takes no position respecting the validity of any patent rights asserted in connection with any item mentioned in this standard. Users of this standard are expressly advised that determination of the validity of any such patent rights, and the risk of infringement of such rights, are entirely their own responsibility.

This standard is subject to revision at any time by the responsible technical committee and must be reviewed every five years and if not revised, either reapproved or withdrawn. Your comments are invited either for revision of this standard or for additional standards and should be addressed to ASTM Headquarters. Your comments will receive careful consideration at a meeting of the responsible technical committee, which you may attend. If you feel that your comments have not received a fair hearing you should make your views known to the ASTM Committee on Standards, 100 Barr Harbor Drive, West Conshohocken, PA 19428.