



Standard Test Method for Thermal Conductivity of Whiteware Ceramics¹

This standard is issued under the fixed designation C 408; the number immediately following the designation indicates the year of original adoption or, in the case of revision, the year of last revision. A number in parentheses indicates the year of last reapproval. A superscript epsilon (ϵ) indicates an editorial change since the last revision or reapproval.

This standard has been approved for use by agencies of the Department of Defense.

1. Scope

1.1 This test method covers a general procedure² for determining the thermal conductivity of whiteware ceramics over the temperature range from 100 to 300°F (40 to 150°C).

1.2 The values stated in inch-pound units are to be regarded as the standard. The SI (metric) units given in parentheses are for information purposes only.

1.3 *This standard does not purport to address all of the safety concerns, if any, associated with its use. It is the responsibility of the user of this standard to establish appropriate safety and health practices and determine the applicability of regulatory limitations prior to use.*

2. Significance and Use

2.1 This test method provides information useful in understanding and quantifying such parameters as thermal shock resistance and ability to conduct or dissipate heat.

3. Apparatus

3.1 Essentially, the apparatus³ shall consist of a heating unit, upper and lower copper “thermodes” (bars that serve to introduce heat) to which the ceramic test specimen is soldered, and a cooling jacket. The foregoing set of parts shall be enclosed by a 5-in. (127-mm) diameter brass cylinder, 12 in. (305 mm) long, which is sealed to the base with a rubber gasket. With the exception of the copper thermodes and the copper cooling jackets, the instrument shall be made entirely of brass with all joints silver soldered. During operation, the system shall be evacuated to a pressure of approximately 1 μ m of mercury with an oil-diffusion pump which is backed up with a mechanical vacuum pump.

3.1.1 *Heating Unit*—The heating unit, shown in detail in Fig. 1, shall consist of a 500-W Nichrome element helically

supported by ceramic insulators inside a 2-in. (50.8-mm) diameter brass cylinder. This brass cylinder shall be highly polished to serve also as a reflector, since heat transmission to the upper thermode is primarily by radiation. Line voltage to the heater circuit shall be held constant to within ± 0.1 % by means of an electronic voltage regulator, and power input to the heater shall be controlled by a variable transformer.

3.1.2 *Thermodes*—The thermodes to which the ceramic test specimen is soldered shall be machined from electrolytically deposited pure copper to tolerances of ± 0.001 in. (0.03 mm) on diameters. Thermodes of diameters from 0.250 to 0.500 in. (6.50 to 12.70 mm) may be used, but in all cases the diameters of the specimen, and that portion of the upper and lower thermodes incorporating the thermocouple shall be equal in diameter to within ± 0.001 in. (0.03 mm). The section of the upper thermode above the upper cooling jacket shall be coated with carbon black to increase its emissivity.

3.1.3 *Cooling Jackets*—Details of the lower cooling jacket are shown in Fig. 1. The lower thermode makes contact with the lower cooling jacket by means of a tapered fit. The upper $\frac{1}{8}$ -in. (3.2-mm) brass plate which supports the heating unit shall also be water-cooled for the purpose of eliminating radiation from the heating unit to the thermodes and test specimen below. In addition, the upper thermode shall be fitted with a copper reflecting shield to prohibit any direct radiation from striking the thermodes and specimen in the chamber below. A water-circulating system shall be provided for supplying the cooling jackets with water at constant pressure and temperature. The water temperatures shall not vary at a rate greater than 1°F (0.5°C)/h.

3.1.4 *Thermocouples*—Calibrated glass-asbestos insulated iron-constantan thermocouples shall be permanently attached to the thermodes in positions 1.75 in. (44.4 mm) apart as noted in Fig. 2. The diameter of the thermocouple wires used shall not exceed the diameter of No. 28 AWG (0.321 mm). The thermocouple wires shall be permanently attached to the thermode by silver-soldering each wire of the thermocouple into No. 70 (0.028-in. diameter) (0.71-mm) holes drilled in the thermode to a depth of $\frac{1}{32}$ in. (0.8 mm) on opposite ends of a diameter. All thermocouple wires shall be taken through the base plate without any break in the continuity of the wire. An ice-water bath shall be used for cold junction reference. The instrument for measuring emf shall not have an instrument

¹ This test method is under the jurisdiction of ASTM Committee C-21 on Ceramic Whitewares and Related Products and is the direct responsibility of Subcommittee C21.03 on Test Methods for Whiteware Properties.

Current edition approved Sept. 30, 1988. Published November 1988. Originally published as C 408 – 57 T. Last previous edition C 408 – 88 (1994).

² This work was done under the sponsorship of the U.S. Signal Corps., Squier Signal Laboratory, Ft. Monmouth, NJ, and the U.S. Air Force, Wright-Patterson Air Development Center, OH.

³ A suitable type of apparatus is described by Edwin Ruh in “Improved Method of Measuring Thermal Conductivity of Dense Ceramics,” *Journal, Am. Ceramic Society*, Vol 37, 1954, No. 5, pp. 224–229.

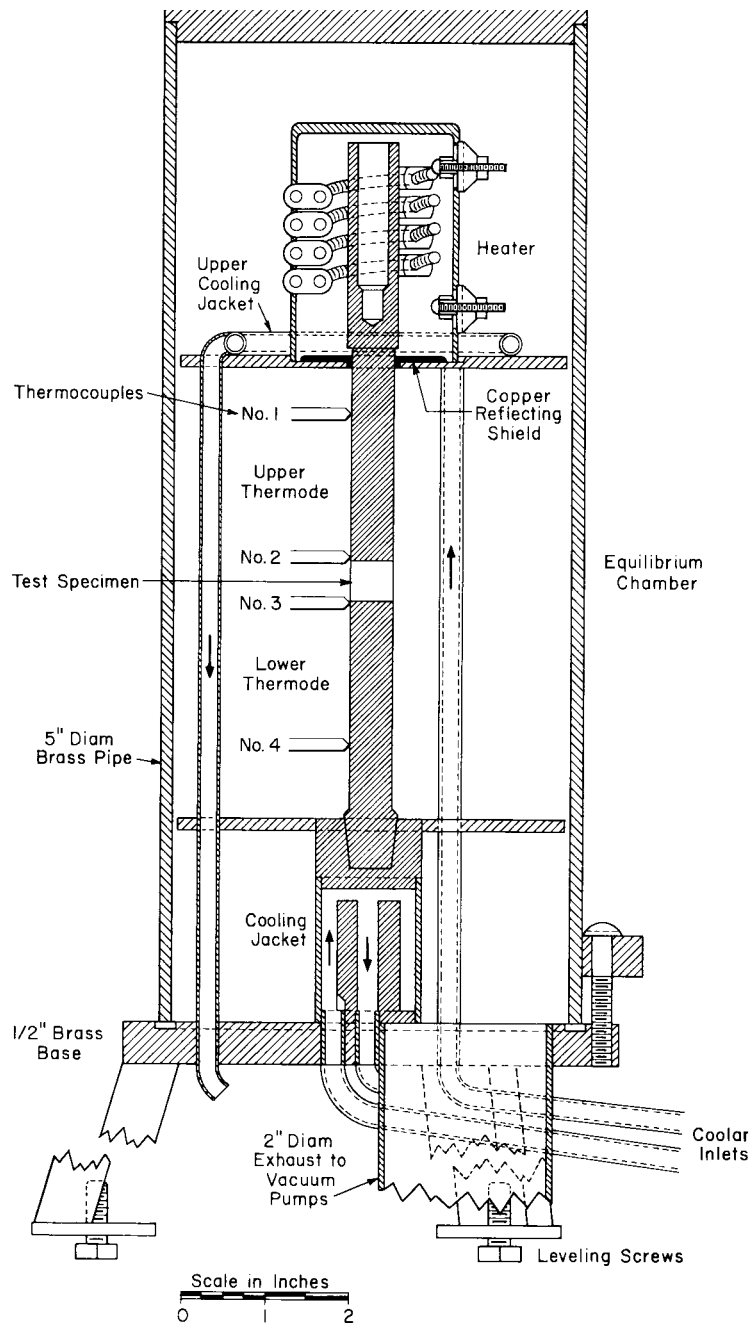

FIG. 1 Thermal Conductivity Apparatus

error greater than ± 0.001 mV.

4. Test Specimens

4.1 The ceramic test specimens used in the thermal conductivity instrument shall be accurately ground cylinders. The specimens may be formed using normal ceramic procedures of slip-casting, dry-pressing, or extrusion. After firing to maturity, the specimens shall be ground to within ± 0.001 in. (0.03 mm) of the diameter of the thermodes being used. The bases shall be perpendicular to the axis of the cylinder within ± 15 min. The length of the cylinder shall be equal to its diameter within $\pm 1\%$.

5. Preparation of Test Specimens

5.1 Metallize the plane faces of the specimen to be evalu-

ated with a fired-on platinum alloy, silver, or other metallic glaze that may be readily soft soldered. Then soft solder the metallized specimen into position between the upper and lower thermodes by placing solder preforms between the specimen and thermode and applying heat to the thermode. Upon completion of this soldering operation, polish the thermodes to reduce their emissivity.

6. Procedure

6.1 After the test specimen has been satisfactorily soldered to the thermodes, and positioned in the apparatus, close off the system and evacuate it to approximately $1 \mu\text{m}$ of mercury. Then apply heat to the upper thermode by means of the heater element and establish a temperature gradient along the copper

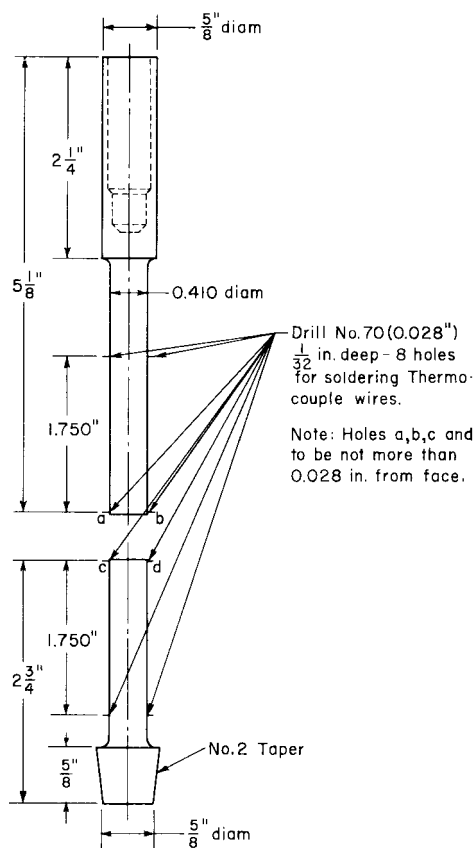

NOTE 1—1 in. = 25.4 mm.

FIG. 2 Detail of Thermodes for 0.410-in. (10.41-mm) Diameter Specimen

and along the specimen. When the heat input equals the heat flowing down the thermode, steady-state conditions have been attained. For practical purposes, when the temperature of the thermocouple nearest the heater element changes at some rate smaller than 0.05°F (0.03°C)/min, steady-state is considered attained. After steady-state conditions have been reached, read the emf of the four thermocouples in the following order: 1, 2, 3, 4, 3, 2, and 1, No. 1 thermocouple being the one nearest the heater element. Then convert the average emf for each thermocouple to temperature for use in the calculations. Take three such sets of readings at each steady-state point. The three calculated thermal conductivity values must agree with each other within 1 % to be acceptable.

7. Recording Test Data

7.1 Record the following test:

7.1.1 Linear dimensions of the test specimen,

7.1.2 Weight of the dry specimen before metallizing,

7.1.3 Diameter of the thermodes,

7.1.4 Distance between thermocouples Nos. 1 and 2,

7.1.5 Three sets of temperature readings, measured by the thermocouples as described in Section 4 for each set of steady-state conditions,

7.1.6 Mean temperature of the upper thermode, as calculated from temperatures measured with the thermocouples Nos. 1 and 2, and

7.1.7 Mean temperature of the samples as calculated from temperatures measured with thermocouples Nos. 2 and 3.

8. Calculation

8.1 Calculate the thermal conductivity as follows:

$$K_s = (K_{Cu}A_{Cu}t_{Cu}X_s)/A_s t_s X_{Cu} \quad (1)$$

where:

K_s = thermal conductivity of the test specimen expressed in Btu-in./h-ft²·°F (or g-cal/s-cm²·°C),

K_{Cu} = thermal conductivity of the copper thermode at the mean temperature calculated in 7.1.6, expressed in Btu-in./h-ft²·°F (or g-cal-cm/s-cm²·°C (Table 1)),

A_{Cu} = cross-sectional area of the thermode, taken perpendicular to the direction of the heat flow,

A_s = cross-sectional area of the specimen, taken perpendicular to the direction of the heat flow,

t_{Cu} = temperature difference in °F (or °C) between thermocouple Nos. 1 and 2,

t_s = temperature difference in °F (or °C) between thermocouple Nos. 2 and 3,

X_s = length of the specimen, and

X_{Cu} = distance (or centimetres) between thermocouple Nos. 1 and 2.

NOTE 1—In taking measurements and making calculations, care should be taken not to mix inch-pound and metric units. For purposes of conversion the following factor may be used:

$$1 \text{ Btu-in./h-ft}^2 \cdot \text{°F} = 0.000 \, 345 \text{ g-cal-cm/s-cm}^2 \cdot \text{°C}.$$

9. Report

9.1 Report the following information:

9.1.1 General description of the material being tested,

9.1.2 Thermal conductivity data reported at the mean specimen temperature calculated in 7.1.7, and

9.1.3 A curve showing the actual thermal conductivity values plotted as a function of mean temperature.

10. Precision and Bias

10.1 Based on repeated tests made over the thermal conductivity range normally associated with ceramic material using the same sample and on samples having the same composition, the precision of the apparatus is of the order of ±2.5 %.

10.2 Based on thermal conductivity determinations made on vitreous silica, on high purity freezing-point lead, and on high purity freezing-point tin standards, the bias of the apparatus is ±3 %.

11. Keywords

11.1 thermal conductivity; whiteware ceramics

TABLE 1 Thermal Conductivity of Electrolytically Deposited Pure Copper Used for Thermodes

Mean temperature, °F (°C)	Thermal Conductivity (K_{Cu})	
	Inch-Pound Units ^A	Metric Units ^B
32 (0)	2693	0.927
212 (100)	2623	0.903
392 (200)	2590	0.891

^ABtu-in./h-ft²·°F.

^Bg-cal-cm/s-cm²·°C.

 **C 408**

The American Society for Testing and Materials takes no position respecting the validity of any patent rights asserted in connection with any item mentioned in this standard. Users of this standard are expressly advised that determination of the validity of any such patent rights, and the risk of infringement of such rights, are entirely their own responsibility.

This standard is subject to revision at any time by the responsible technical committee and must be reviewed every five years and if not revised, either reapproved or withdrawn. Your comments are invited either for revision of this standard or for additional standards and should be addressed to ASTM Headquarters. Your comments will receive careful consideration at a meeting of the responsible technical committee, which you may attend. If you feel that your comments have not received a fair hearing you should make your views known to the ASTM Committee on Standards, at the address shown below.

This standard is copyrighted by ASTM, 100 Barr Harbor Drive, PO Box C700, West Conshohocken, PA 19428-2959, United States. Individual reprints (single or multiple copies) of this standard may be obtained by contacting ASTM at the above address or at 610-832-9585 (phone), 610-832-9555 (fax), or service@astm.org (e-mail); or through the ASTM website (www.astm.org).