

**Group 1**  
**Supply Air Fittings at the Air Handling Equipment**  
Reference Velocity = 900 Fpm  
Reference Friction Rate = 0.08 IWC per 100 Feet

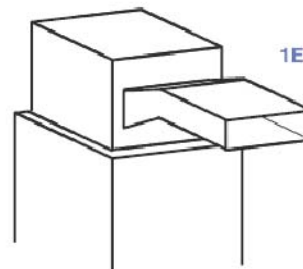

**Group 1 — Continued**  
**Supply Air Fittings at the Air Handling Equipment**  
 Reference Velocity = 900 Fpm  
 Reference Friction Rate = 0.08 IWC per 100 Feet

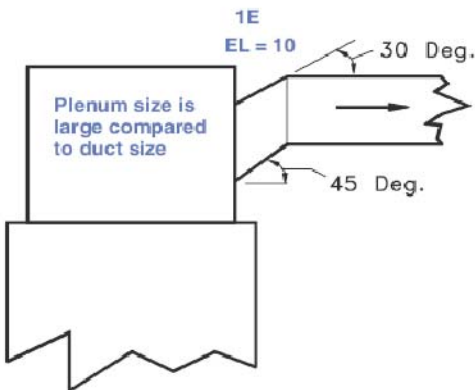
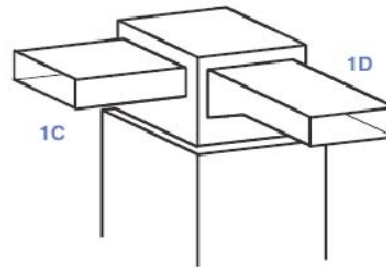
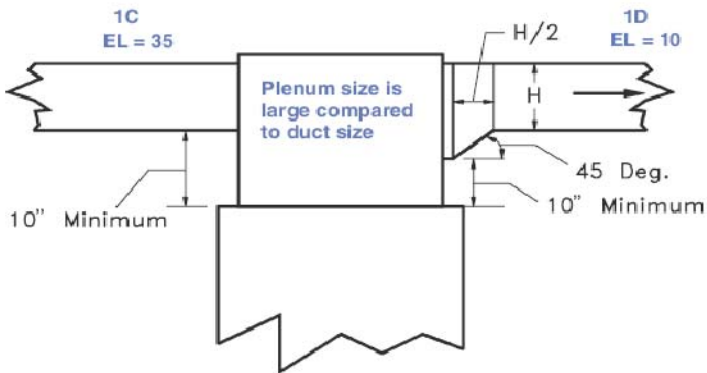
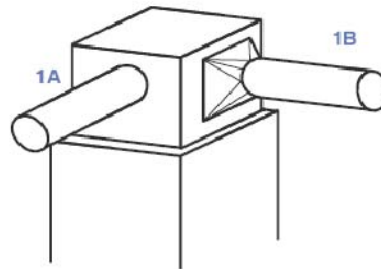
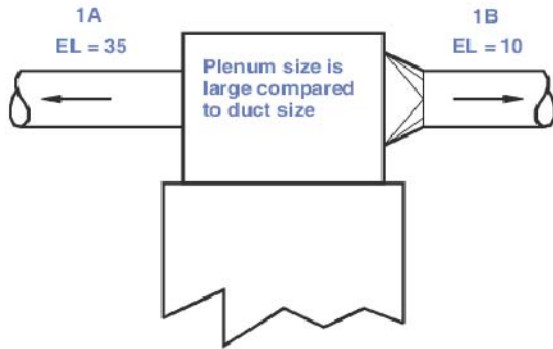
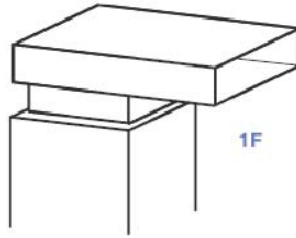
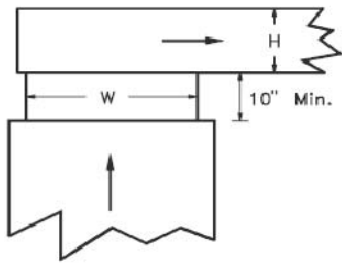

Bull Head 1F	H / W	EL
	0.50	120
	1.0	85

Tapered Head 1G	H / W	EL
	0.50	35
	1.0	25

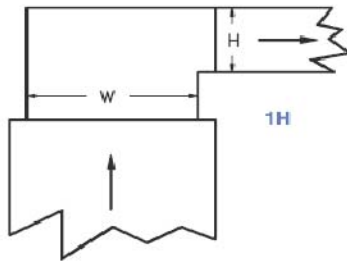
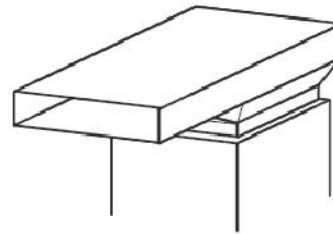
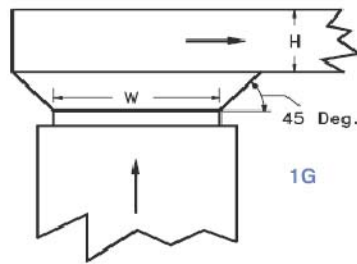

No Vanes 1H	H / W	EL
	0.5	120
	1.0	85

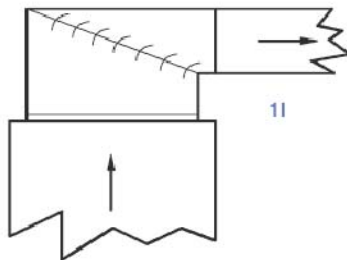
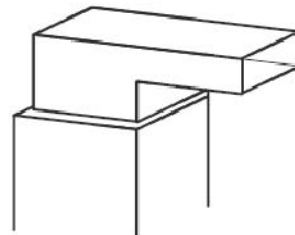

With Vanes 1I	EL = 20
------------------	---------

**Group 1 — Continued**  
**Supply Air Fittings at the Air Handling Equipment**  
 Reference Velocity = 900 Fpm  
 Reference Friction Rate = 0.08 IWC per 100 Feet

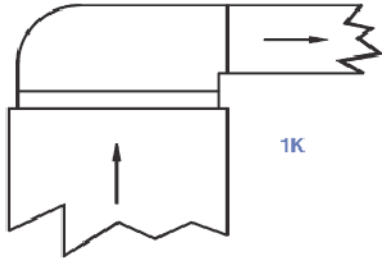

Mitered Inside Corner 1K	EL = 85
-----------------------------------	---------

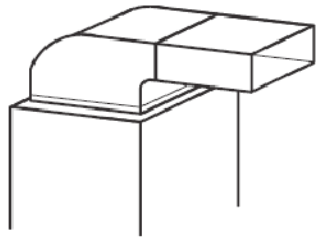
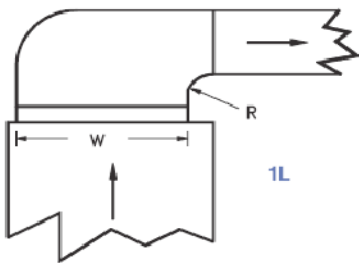

Radius Elbow No Vanes 1L	R / W	EL
	0.25	40
	0.50	20
	1.0	10

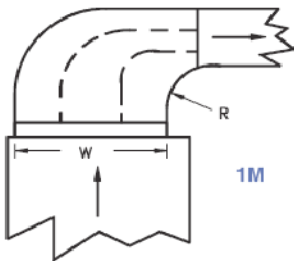

		1-Vane	2-Vane
Radius Elbow with Vanes 1M	R / W	EL	EL
	0.05	30	20
	0.25	20	10
	0.50	10	10

Add the transition EL to the upstream elbow EL (or tee EL)

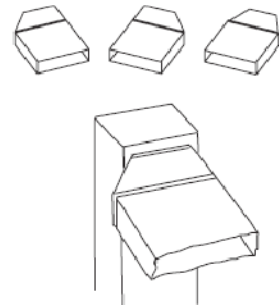
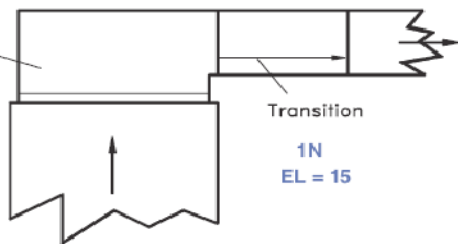

**Group 1 — Continued**  
**Supply Air Fittings at the Air Handling Equipment**  
 Reference Velocity = 900 Fpm  
 Reference Friction Rate = 0.08 IWC per 100 Feet

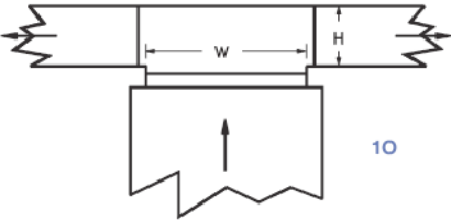

Bull Head No Vanes 10	H / W	EL
	0.50	120
	1.0	85

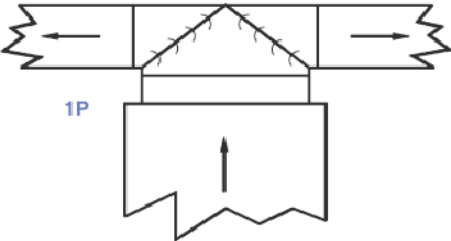
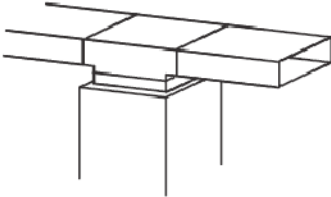

Vaned Tee 1P	EL = 20
	EL = 20

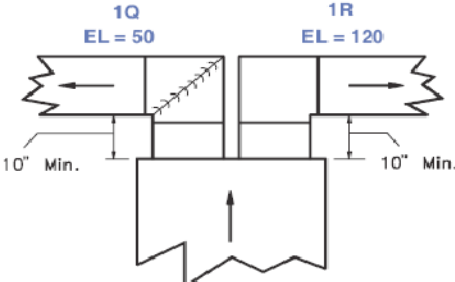
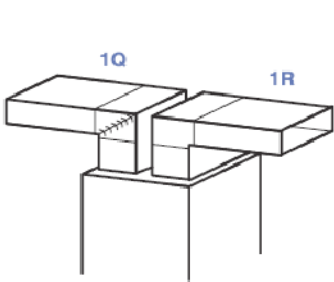

Radius Elbow 1S	Vaness	EL
	0	60
	1	40
	2	30

