

TAG: \_\_\_\_\_

# SUBMITTAL

NOTE: All dimensions are in mm/inches.

## 3 Ton Split System Cooling — 1 Phase 2TTB3036A

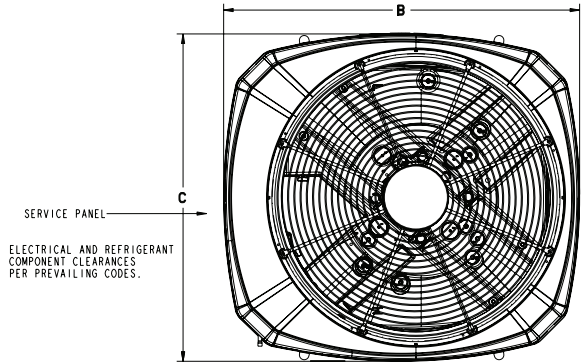

SERVICE PANEL  
ELECTRICAL AND REFRIGERANT  
COMPONENT CLEARANCES  
PER PREVAILING CODES.

TOP DISCHARGE AREA SHOULD BE UNRESTRICTED FOR AT LEAST 1524 (5 FEET) ABOVE UNIT. UNIT SHOULD BE PLACED SO ROOF RUN-OFF WATER DOES NOT POUR DIRECTLY ON UNIT, AND SHOULD BE AT LEAST 305 (12") FROM WALL AND ALL SURROUNDING SHRUBBERY ON TWO SIDES. OTHER TWO SIDES UNRESTRICTED.

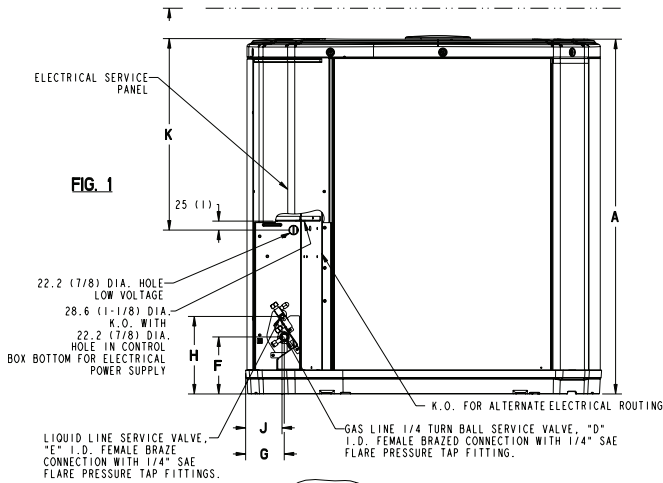

FIG. 1

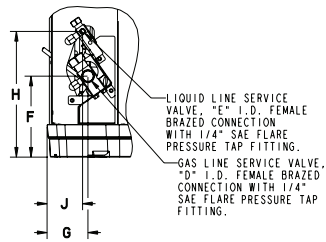

FIG. 2

### Product Specifications

OUTDOOR UNIT ①②	2TTB3036A1000N
<b>POWER CONNS. — V/PH/HZ ③</b>	208/230/1/60
MIN. BRCH. CIR. AMPACITY	21
BR. CIR. } MAX. (AMPS)	35
PROT. RTG. } MIN. (AMPS)	35
<b>COMPRESSOR</b>	SCROLL
NO. USED - NO. SPEEDS	1 - 1
VOLTS/PH/HZ	208/230/1/60
R.L. AMPS ⑦ - L.R. AMPS	15.4 - 87
FACTORY INSTALLED	
START COMPONENTS ⑧	NO
INSULATION/SOUND BLANKET	NO
COMPRESSOR HEAT	NO
<b>OUTDOOR FAN</b>	PROPELLER
DIA. (IN.) - NO. USED	23 - 1
TYPE DRIVE - NO. SPEEDS	DIRECT - 1
CFM @ 0.0 IN. W.G. ④	4400
NO. MOTORS - HP	1 - 1/6
MOTOR SPEED R.P.M.	825
VOLTS/PH/HZ	200/230/1/60
F.L. AMPS	1.3
<b>OUTDOOR COIL — TYPE</b>	SPINE FIN™
ROWS - F.P.I.	1 - 24
FACE AREA (SQ. FT.)	18.75
TUBE SIZE (IN.)	3/8
<b>REFRIGERANT</b>	
LBS. — HCFC-22 (O.D. UNIT) ⑤	6 LBS. - 5 OZ.
FACTORY SUPPLIED	NO
LINE SIZE - IN. O.D. GAS ⑥	7/8
LINE SIZE - IN. O.D. LIQ. ⑥	3/8
<b>CHARGING SPECIFICATION</b>	
SUBCOOLING	10°F
<b>DIMENSIONS</b>	H X W X D
CRATED (IN.)	38 x 30.1 x 33
<b>WEIGHT</b>	
SHIPPING (LBS.)	205
NET (LBS.)	178

① Certified in accordance with the Unitary Air-Conditioner equipment certification program which is based on AHRI Standard 210/240.  
 ② Calculated in accordance with N.E.C. Use only HACR circuit breakers or fuses.  
 ③ Standard line lengths - 60'. Standard lift - 60' Suction and Liquid line.  
 For Greater lengths and lifts refer to refrigerant piping software Pub# 32-3312-0'. (\*denotes latest revision)

MODELS	BASE	FIG.	A	B	C	D	E	F	G	H	J	K
2TTB3036A	3	2	832 (32-3/4)	829 (32-5/8)	756 (29-3/4)	7/8	3/8	137 (5-3/8)	86 (3-3/8)	210 (8-1/4)	79 (3-1/8)	508 (20)

From Dwg. 21D153074 Rev. 10

### A-weighted Sound Power Level [dB(A)]

MODEL	Product Mkt.	POWER LEVEL [dB(A)]	A-WEIGHTED FULL OCTAVE SOUND POWER LEVEL dB - [dB(A)]							
			63	125	250	500	1000	2000	4000	8000
2TTB3036A1	76	76	44.8	60.5	61.4	69.2	72.1	65.2	57.3	51.3

# Mechanical Specification Options

---

## General

The 2TTB3 is designed to operate at outdoor ambient temperatures as high as 115°F. Cooling capacities shall be matched with a wide selection of air handlers and furnace coils that are A.H.R.I. certified. The unit shall be certified to UL Standard 1995. Exterior must be designed for outdoor application.

## Casing

Unit casing is constructed of heavy gauge, galvanized steel and painted with a weather-resistant powder paint. Corrosion and weatherproof CMBP-G30 base.

## Refrigerant Controls

Refrigeration system controls include condenser fan and compressor contactor. High and low pressure controls are inherent to the compressor. Another standard feature is the liquid line dryer.

## Compressor

The compressor features internal over temperature and pressure protector, total dipped hermetic motor and thermostatically controlled sump heater. Other features include: centrifugal oil pump, and low vibration and noise.

## Condenser Coil

The Spine Fin™ coil shall be continuously wrapped, corrosion resistant all aluminum with minimum brazed joints. This coil is 3/8 inch O.D. seamless aluminum glued to a continuous aluminum fin. Coils are lab tested to withstand 2,000 pounds of pressure per square inch. The outdoor coil provides low airflow resistance and efficient heat transfer. The coil is protected on all four sides by louvered panels.

## Low Ambient Cooling

As manufactured, this unit has a cooling capability to 55°F. The addition of an evaporator defrost control permits operation to 40°F. The addition of an evaporator defrost control with TXV permits low ambient cooling to 30°F.

## Accessories

**Thermostats** — Heating/Cooling (manual and automatic changeover). Sub-base to match thermostat and locking thermostat cover.

**Evaporator Defrost Control** — See Low Ambient Cooling.

**Outdoor Thermostat** — Supplemental heat outdoor ambient lockout from 46 to -10°F.



Trane  
www.trane.com