

TAG: \_\_\_\_\_

# SUBMITTAL

## R-410A Split System 16 -22 SEER, Inverter Systems - 60 Hz 4MXW8512A1 / 4TXK8512A1

### Specifications

MODEL - Heat Pump Only	4MXW8512A1 / 4TXK8512A1	
	Cooling	Heating
RATED Volts/PH	208 / 230 / 1	
Frequency (Hz)	60Hz	
Rated Cooling / Heating Capacity (Btu/h):	12000	13000
Minimum Cooling Capacity (@95F) (Btu/h):	3100	0
Maximum Cooling Capacity (@95F) (Btu/h):	13000	0
Minimum Heating Capacity (@47F) (Btu/h):	0	2400
Maximum Heating Capacity (@47F) (Btu/h):	0	14000
Maximum Heating Capacity (@17F) (Btu/h):	0	7600
Maximum Heating Capacity (@ 5F) (Btu/h):	0	8500
Total Capacity (W) (High/Standard/Low):	3810 / 3517 / 909	4103 / 3810 / 703
Rated Power Input (W)	1000	1200
Nominal Input Current (A)	4.55	5.20
SEER / HSPF	20.0	9.2
Air Flow Volume (CFM) (H/M/L)	335 / 277 / 254 / 218	
Dehumidifying Volume (pt./h)	2.52	
EER (@95F)	12.0	10.83

Indoor Unit	4MXW8512A10NOCA	
Fan Motor Speed (r/min) (SH/H/M/L)	1330 / 1100 / 950 / 750	1350 / 1200 / 1080 / 950
Fan Motor RLA(A)	0.2	
Evaporator	Aluminum Fin-copper Tube	
Pipe Diameter (inch)	0.276	
Row Fin Gap (inch)	2 - 0.055	
Coil length (L) x height (H) x coil width (W) (inch)	22.9 x 1.0 x 10.4	
Output of Swing Motor (W)	2.0	
Fuse (A)	3.15	
Sound Power Level dB (A)(SH/H/M/L)	54 / 49 / 46 / 43	
Sound PRESSURE Level dB (A)(SH/H/M/L) ①	44 / 39 / 36 / 33	
Uncrated Dimension (W/D/H) (inch)	33.3 x 7.1 x 10.8	
Crated Dimension of Package (W/D/H) (inch)	36.1 x 10.2 x 14.6	
Net Weight /Gross Weight (lbs)	22.0 / 28.6	

Outdoor Unit	4TXK8512A10NOBA	
Compressor Type	Rotary	
L.R.A. (A)	10.2	
Compressor RLA(A)	5.34	
Compressor Power Input(W)	860	
Throttling Method	EEV	
Working Temp Range (oF)	-0 ~ 110	5 ~ 75
Condenser	Aluminum Fin-copper Tube	
Pipe Diameter (inch)	0.375	
Row Fin Gap (inch)	2 - 0.055	
Coil length (l) x height (H) x coil width (L) (inch)	29.4 x 22.0 x 1.7	
Fan Motor Speed (rpm)	680/900	
Output of Fan Motor (W)	30	
Fan Motor RLA (A)	0.14	
Air Flow Volume of Outdoor Unit (CFM)	944	
Fan Diameter (inch)	15.7	
Defrosting Method	Automatic Defrosting	
Sound Power Level dB (A)	62	
Sound PRESSURE Level dB (A)(SH/H/M/L) ①	52	
Uncrated Dimension (W/L/H) (inch)	33.4 x 12.6 x 23.2	
Crated Dimension of Package (W/L/H) (inch)	34.7 x 14.3 x 25.4	
Net Weight /Gross Weight (lbs)	88.1 / 96.9	
Refrigerant Charge (oz)	45.86	
MCA	10.0	
MOP	15.0	

Connection Pipe	
Gas additional charge(oz/ft)	0.2
Outer Diameter Liquid Pipe (inch)	1/4
Outer Diameter Gas Pipe (inch)	3/8
Max Height Distance (ft)	65
Max Length Distance (ft)	100

① Sound PRESSURE Level @ 3.3 ft. dB(A)

② 4MXW85 High Wall Models with 14th digit B are phasing out and will be replaced with 14th digit C models (Now compatible with wired controller)

## Indoor Unit

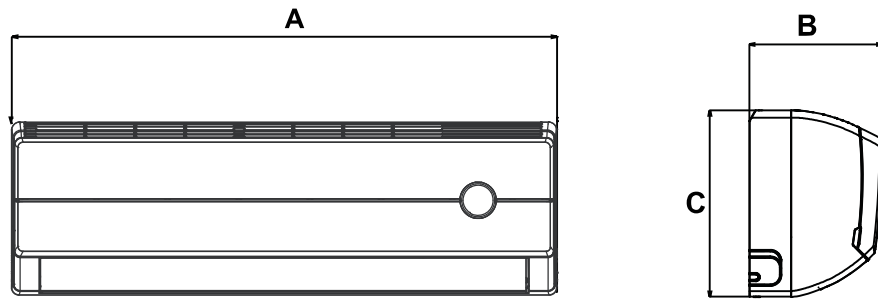

Indoor Unit Dimensions

Unit	W (width)	D (depth)	H (height)
4MXW8512A1	(A) 33.3"	(B) 7.1"	(C) 10.8"

## Outdoor Unit

12K Unit

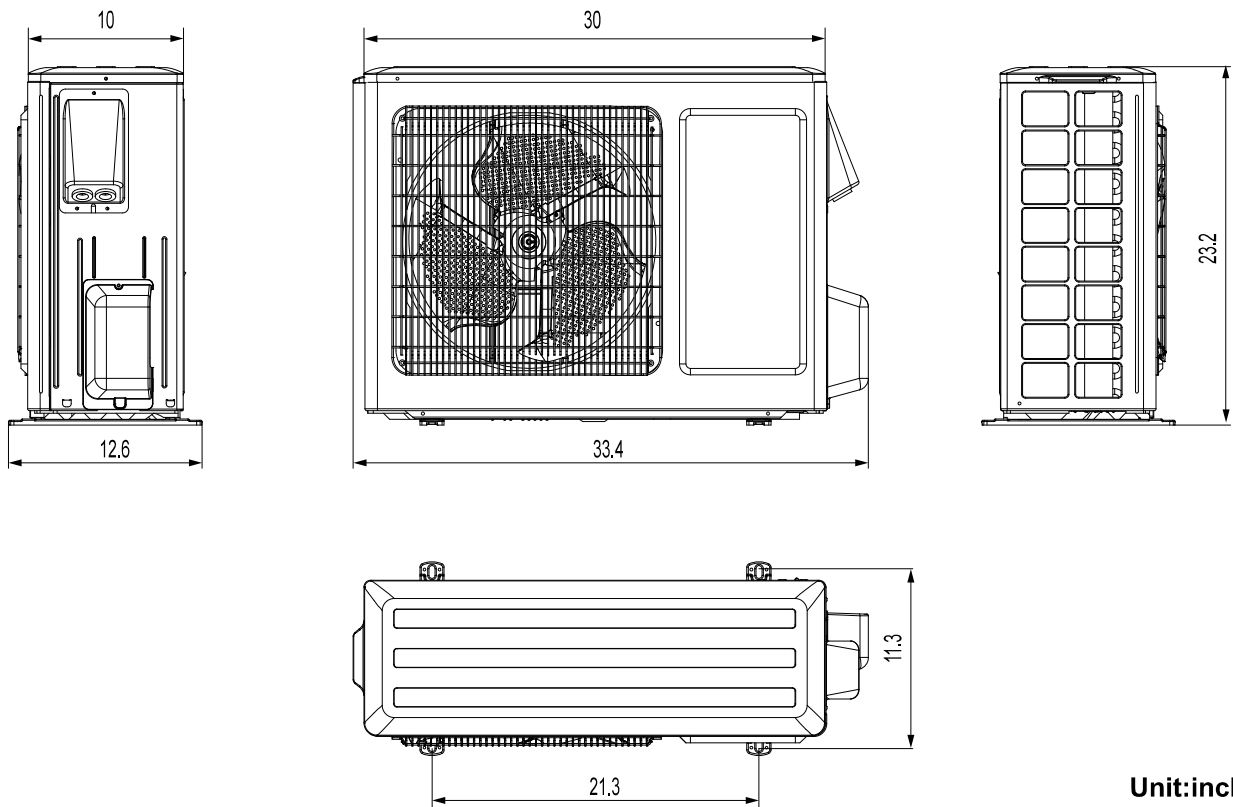

Unit:inch

Air Velocity Patterns for High Wall		
Max Horizontal Distance		
Unit: ft. (m)		
Model	Cooling Mode	Heating Mode
4MXW8512	29.5 (9)	23.6 (7.2)

# Mechanical Specifications

## Mini-Split Outdoor Unit

### General

This unit is fully charged from the factory for up to 25 feet of piping. This unit is designed to operate at outdoor ambient temperatures as high as 110°F. Cooling capacities with the mini-split air handler shown in the catalog are AHRI certified. The unit is ETL listed for outdoor application.

### Unit Casing

The unit casing is constructed of heavy gauge, galvanized steel and painted with a weather-resistant powder paint.

### Refrigerant Controls

Refrigeration system controls include condenser fan and compressor relay. High and low pressure controls are inherent to the compressor. A suction line multi function service valve is standard

### Compressor

The compressor features internal over temperature and pressure protection; total dipped hermetic motor windings. Other features include: centrifugal oil pump and low vibration and noise.

### Condenser Coil

The coil shall consist of aluminum finned coils brazed to copper tubing. The coil provides air flow resistance and efficient heat transfer. The coil is protected by the casing.

### Low Ambient Cooling

Matched ductless products, have a cooling capability to 0° F.

## Mini-Split Indoor High Wall

### General

The High Wall mounted type air handler shall be completely factory assembled including coil, condensate drain pan, fan motor, washable filter, air purifying filter and electric controls to be used with a wireless remote controller. Unit shall be shipped with a unit mounting plate. Unit shall be matched with a corresponding outdoor unit, rated and tested in accordance with AHRI standard. Unit shall be ETL listed.

### Unit Casing

Casing shall be provided with knockouts on the right, and left of the unit to facilitate piping and electrical connection on either side of the unit. An electrical service cover shall be provided to permit easy access to the electrical terminal strip.

### Discharge airflow and Distribution System

Unit shall have auto swing, dual horizontal blades to optimize the aperture outlet for vertical airflow and air distribution. Blade shall close automatically when the air conditioner is turned off to minimize dust entering the unit. Five-Step preset program on the remote controller shall be available to control the blade angle.

Manually adjusted wide-angle louvers shall be provided to adjust the coverage and direction of airflow.

### Controls

Units shall have the capability to be controlled remotely.

### Remote Controller

The unit shall have a wireless infrared remote controller with easy reading digital display panel to start, stop and regulate the air conditioner from a distance.

The wireless controller is available for all units. **(Sold separately)**

### Healthy Filters

The unit shall have one combined active carbon and catechin filter with the unit. The filter needs to be cleaned at least once a year.



10/14

The manufacturer has a policy of continuous product and product data improvement and it reserves the right to change design and specifications without notice.