



TRANE®

Owner's Manual

Split System (R-410A)

Inverter Multi-split

9,000 to 34,000 BTU/Hr



R-410A, 60Hz

Multi Split
Heat pump

Indoor Unit
4MXW6-A

Outdoor Unit
4TXW6-A

April 2010

MS-SVU42A-EN



Warnings and Cautions

Warnings and Cautions. Notice that warnings and cautions appear at appropriate intervals throughout this manual. Warnings are provided to alert installing contractors to potential hazards that could result in personal injury or death, while cautions are designed to alert personnel to conditions that could result in equipment damage.

Your personal safety and the proper operation of this machine depend upon the strict observance of these precautions.

Attention: Warnings and Cautions appear at appropriate sections throughout this literature. Read these carefully.

⚠ WARNING: Indicates a potentially hazardous situation which, if not avoided, could result in death or serious injury.

⚠ CAUTION: Indicates a potentially hazardous situation which, if not avoided, could result in minor or moderate injury. It may also be used to alert against unsafe practices.

NOTICE: Indicates a situation that could result in equipment or property-damage only accidents.

⚠ WARNING

Ground Required!

Follow proper local electrical code on requirements for grounding. Failure to follow code could result in death or serious injury.

⚠ WARNING

This information is intended for use by individuals possessing adequate backgrounds of electrical and mechanical experience. Any attempt to repair a central air conditioning product may result in death, personal injury or property damage. The manufacturer or seller cannot be responsible for the interpretation of this information, nor can it assume any liability in connection with its use.

⚠ WARNING

R410A Refrigerant under Higher Pressure than R22!

The units described in this manual use R410A refrigerant which operates at 50 to 70% higher pressures than R-22. Use only R-410A approved service equipment. Refrigerant cylinders are painted with "pink" color to indicate the type of refrigerant and may contain a "dip" tube to allow for charging of liquid refrigerant into the system. For specific handling concerns with R-410A, please contact your local Trane representative.

Failure to use R-410A approved service equipment could result in standard equipment exploding under R-410A higher pressure which could result in death or serious injury.



Warnings and Cautions

NOTICE

Use PVE Oil with R-410A Mini-Split Units!

All R-410A mini-splits use a PVE oil (Polyvinyl Ether Oil) that readily absorbs moisture from the atmosphere. To limit this “hygroscopic” action, the system should remain sealed whenever possible. If a system has been open to the atmosphere for more than 4 hours, the compressor oil must be replaced. Never break a vacuum with air and always change the driers when opening the system for component replacement. For specific handling concerns with PVE oil, contact your local Trane representative.

USE ONLY THE FACTORY RECOMMENDED - DAFNE HERMETIC OIL FV50S - for servicing these units.

Failure to follow these recommendations could result in equipment damage.

Important!

Environmental Concerns

Scientific research has shown that certain man-made chemicals can affect the earth’s naturally occurring stratospheric ozone layer when released to the atmosphere. In particular, several of the identified chemicals that may affect the ozone layer are refrigerants that contain Chlorine, Fluorine and Carbon (CFCs) and those containing Hydrogen, Chlorine, Fluorine and Carbon (HCFCs). Not all refrigerants containing these compounds have the same potential impact to the environment. Trane advocates the responsible handling of all refrigerants—including industry replacements for CFCs such as HCFCs and HFCs.

Responsible Refrigerant Practices

Trane believes that responsible refrigerant practices are important to the environment, our customers, and the air conditioning industry. All technicians who handle refrigerants must be certified. The Federal Clean Air Act (Section 608) sets forth the requirements for handling, reclaiming, recovering and recycling of certain refrigerants and the equipment that is used in these service procedures. In addition, some states or municipalities may have additional requirements that must also be adhered to for responsible management of refrigerants. Know the applicable laws and follow them.

Contents

General Information	5
Model Numbers	6
Recommendations	7
Typical installation	8
Remote Control Operation	9
Names and functions of wireless remote control	9
General operation	11
Optional operation	12
Explanation of special functions	12
Changing batteries	13
Maintenance	14
Cleaning the Front Panel	14
Cleaning the air filters	15
Troubleshooting	16
Operation	18
Emergency Operation	18
Working principle of cooling mode	18
Working principle of heating mode	19



General Information

This Owner's Manual is given as a guide to good practices in the operation of a wall mounted split system. However it does not contain all the service procedures for this unit, as these procedures must be performed by a qualified service technician, through the maintenance contract with a reputable service company.

Read these operation instruction completely before using the air conditioning.

Warranty

Warranty is based on the general terms and conditions by country. The warranty is void if the equipment is modified or repaired without the written approval of The Trane Company, if the operating limits are exceeded or if the control system or the electrical wiring is modified.

Damage due to inappropriate installation, lack of knowledge or failure to comply with the manufacturer's instructions, is not covered by the warranty obligation.

If the installation does not conform to the rules described in Installation Manual, it may entail cancellation of warranty and liabilities by The Trane Company.

Reception

On arrival, inspect the unit before signing the delivery note. Specify any damage of the unit on the delivery note, and send a registered letter of protest to the last carrier of the goods within 72 hours of delivery. Notify the dealer at the same time.

The unit should be totally inspected within 7 days of delivery. If any concealed damage is discovered, send a registered letter of protest to the carrier within 7 days of delivery and notify the local dealer.

About the Unit

These units are assembled, pressure tested, dehydrated, charged and run tested before shipment.

Refrigerant

The refrigerant provided by the manufacturer complies with all the requirements for our units. When using a recycled or reprocessed refrigerant, we recommend its qualities be as good as those of a new refrigerant. It is necessary to have the refrigerant tested by a qualified laboratory. Failure to do so could void the warranty.

Important

These instructions do not cover all variations in systems, nor do they provide for every possible contingency to be met in connection with installation. Should further information be desired or should particular problems arise which are not covered sufficiently in this manual, the matter should be referred to your authorized Trane dealer.



Model Numbers

High Efficiency Inverter Multi-split, R-410A

60 Hz

Indoor Units

Outdoor Unit

Heat pump

4MXW6509B1

4TXM6518A1

4MXW6512B1

4TXM6524A1

4MXW6518B1

4TXM6528A1



Recommendations

The followings are general recommendations that are necessary to follow to obtain maximum performance from your air conditioner:

- Don't leave windows and doors open for a long time while operating the air conditioner. It can decrease the air conditioning capacity.
- Don't put a space heater near the air conditioner, it can decrease the air conditioner capacity.
- When the air conditioner will not be used for a long time, turn off the power supply.

NOTICE

Air Flow Restriction!

Ensure no restriction of air flow to or from the unit or system. Failure to do so could result in poor performance or cause equipment damage.

⚠ WARNING

Safety Recommendations!

The followings are safety recommendations that if not followed could result in death or serious injury:

If a burning smell or smoke occurs, please turn off the power supply and contact your Trane dealer. The unit may be damaged, and may cause electric shock or fire.

Do not use flammable sprays near the air conditioner. They can cause a fire or explosion.

Don't attempt to repair the air conditioner by yourself. Incorrect repair could lead to an electric shock or fire, so repairs should only be made by qualified Trane technicians.

The power supply must be of proper amperage and conform with local codes.

Please don't cut or damage the power cords and control cords. Electric shock or fire could result. If they are damaged, please ask the qualified personnel to change them.

Do not operate the unit without the filters installed. Otherwise, dirt may enter the unit and cause damage. Filters should be removed and cleaned periodically to assure maximum efficiency.

Typical installation

Names and functions of each part

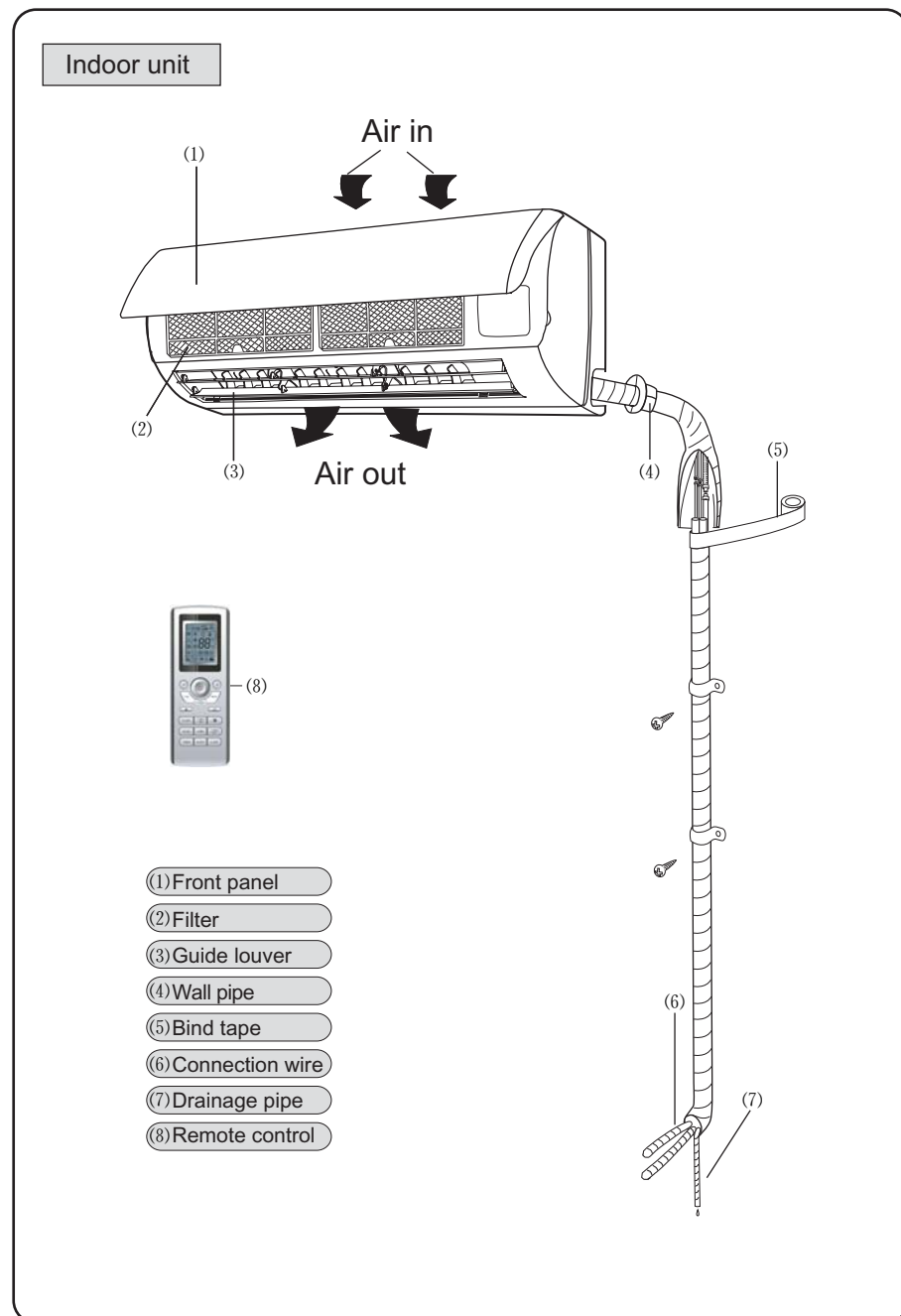



Remote Control Operation

Name and function of wireless remote control

Note: Be sure that there are no obstructions between receiver and remote controller; Don't drop or throw the remote control. Don't let any liquid in the remote control or put the remote control directly under the sunlight or any place where is very hot.

Signal transmitter



Remote control

SLEEP

SLEEP Button

- Press this button, Sleep On and Sleep Off can be selected. After powered on, Sleep Off is defaulted. After the unit is turned off, the Sleep function is canceled. After Sleep function set up, the signal of Sleep will display. In this mode, the time of timer can be adjusted. Under Fan and Auto modes, this function is not available.

FAN

FAN Button

- Press this button to choose between Auto, Low, Middle, or High speed. Auto fan speed is default on power up. Under Blow mode, Low fan speed only can be set up.

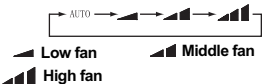

CLOCK

CLOCK Button

- Press this button to set up the clock time. Once the signal and display begin to blink, the time can be adjusted by pressing + or - button. (Press + or - button continuously to change timing value quickly), the setting time range is from 0.5 to 24 hr.; press this key once again to fix the time, then remote controller will send out the signal immediately and hour on/off will stop flickering. If no button is pushed for 5 seconds while the display is still flashing, the timer setting will not be saved. Press the clock button once to exit the timer setting.

TEMP

TEMP Button

- Use this button to set up and select temperature options: temperature setting (displays the room temperature selected), indoor ambient temperature (actual room temperature).

ON/OFF Button

- Press this button, the unit will be turned on, press it once more, the unit will be turned off. When turning on or turning off the unit, the Timer, Sleep function will be canceled, but the clock time will be saved.

MODE

MODE Button

- Press this button to switch between modes (Auto, Cool, Dry, Fan and Heat) as shown below. Auto mode is default while power on. Under Auto mode, the temperature will not be displayed; Under Heat mode, the initial value is 28°C (82°F); Under other modes, the initial value is 25°C (77°F).

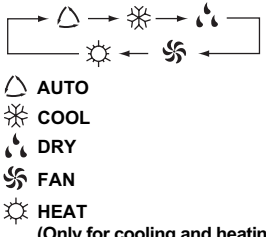

△ AUTO
 ❄️ COOL
 💧 DRY
 🌀 FAN
 ☀️ HEAT
 (Only for cooling and heating unit.)

Names and functions of wireless remote control

Notice: This is a general use remote controller, and not all features may be included with your system. Some buttons may be de-activated.



Remote control

BLOW

BLOW Button

- In the cool or dry mode, pressing the button once will activate the "blow" function (see page 12): Press the button once and "DRY" will be displayed and the blow function will be active. Press the button a second time and "DRY" will be concealed and the blow function is canceled. If operating the ON/OFF button and changing the mode from COOL to DRY, the status of BLOW will stay in the original position. This function is not available under the AUTO, FAN or HEAT mode.

TURBO

TURBO Button

- In Cool or Heat mode, use this button to activate the Turbo function. When the signal is displayed, the unit will run at the highest fan speed to rapidly cool or heat the room to the preset temperature as quickly as possible. Turbo mode is automatically cancelled if the mode or fan speed is changed.

+

+ Button

- Use this button to increase the temperature setting. Depress the button continuously for two seconds to increase the setting rapidly. Release the button to send the setting to the unit, and the °C (°F) will be continuously displayed. Temperature range for Celsius degree setting is 16-30; for Fahrenheit degree setting is 61-86. This temperature adjustment is not available in the AUTO mode.

-

- Button

- Use this button to decrease the temperature setting. Depress the button continuously for two seconds to decrease the setting rapidly. Release the button to send the setting to the unit, and the °C (°F) will be continuously displayed. Temperature range for Celsius degree setting is 16-30; for Fahrenheit degree setting is 61-86. This temperature adjustment is not available in the AUTO mode.

LIGHT

LIGHT Button

- When unit is powered on, Light On is defaulted. Use this button to switch between Light On and Light Off.

Name and function of wireless remote control

Notice: This is a general use remote controller, and not all features may be included with your system. Some buttons may be de-activated.



Remote control



SWING UP and DOWN Button

- Press this button to select and set up the swing angle as shown in the sequence below:



This is an universal use remote controller. If remote controller sends the following three kinds of status that the swing status of main unit will be:



When the guide louver start to swing up and down, if turn off the Swing, the air guide louver will stop at current position.

indicates the guide louver swings up and down between that all five positions.

Under swing up and down mode, when the status is switched from off to , if press this button again 2s later, status will switch to off status directly; if press this button again within 2s, the change of swing status will also depend on the circulation sequence stated above.

TIMER ON

TIMER ON Button

- To set the TIMER, press the Timer On button (be certain the clock displays the actual time). The "ON" signal will blink, the signal will be concealed, and the numerical display will become the timer on setting. To adjust the time value of the setting, press the + or - button during the initial 5 second blinking period. Each time the + or - button is pushed, the setting will be changed by one minute. Hold the + or - button continuously to adjust the time setting rapidly. First, the time setting is adjusted in 10 minute intervals. Release the + or - button and press the Timer On button while the display continues to blink for 5 seconds. The Timer On setting is now active. Press the Timer On button once again to cancel this setting.

TIMER OFF

TIMER OFF Button

- Use this button to set the TIMER OFF time. The method of setting is the same as for TIMER ON.

I FEEL

I FEEL Button

- When this button be pressed, the remote controller senses its ambient temperature and keep sending signals to the air conditioner's PCB every 10 minutes, then the latter adjusts the capacity output accordingly so as to maintain the room temperature at the most comfortable level. To retain this operation, the remote controller should be kept pointing at the indoor unit so as to guarantee smooth communication. If the air-conditioner does not receive signal within 11 minutes, it will run according to the temperature sensed by itself.

Guide for operation- general operation

1. After powered on, press ON/OFF button, the unit will start to run.(Note: When it is powered off, the guide louver of main unit will close automatically.)
2. Press MODE button, select desired running mode, or press COOL or HEAT mode to enter into the corresponding operation directly.
3. Pressing + or - button, to set the desired temperature (It is unnecessary to set the temp. at AUTO mode.)
4. Pressing FAN button, set fan speed, can select AUTO FAN, LOW, MID and HIGH.
5. Pressing  button, to select the swing.

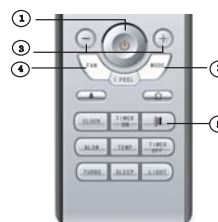

Guide for operation- Optional operation

1. Press SLEEP button to enter sleep mode.
2. Press TIMER ON and TIMER OFF button to set the scheduled timer for operation.
3. Press LIGHT button to turn the display on and off.
4. Press TURBO button to activate the turbo mode.

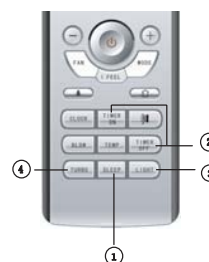

Introduction for special function

★ About blow function

This function allows removal of moisture on the evaporator of the indoor unit after the unit has stopped in order to prevent mold. When the blow function is activated, the indoor fan will continue to run for 10 minutes after the unit is turned off by pressing the ON/OFF button.

1. Having set blow function on: After turning off the unit by pressing ON/OFF button indoor fan will continue running for about 10 min. at low speed. In this period, press blow button to stop indoor fan directly.
2. Having set blow function off: After turning off the unit by pressing ON/OFF button, the complete unit will be off directly.

★ About AUTO RUN

When AUTO RUN mode is selected, the setting temperature will not be displayed on the LCD, the unit will be in accordance with the room temp. automatically to select the suitable running method and to make ambient comfortable.

★ About turbo function

If start this function, the unit will run at super-high fan speed to cool or heat quickly so that the ambient temp. approaches the preset temp. as soon as possible.

★ About lock

Press + and - buttons simultaneously to lock or unlock the keyboard. If the remote controller is locked, the icon  will be displayed on it, in which case, press any button, the mark will flicker for three times. If the keyboard is unlocked, the mark will disappear.

★ About switch between Fahrenheit and Centigrade

Under status of unit off, press MODE and - buttons simultaneously to switch °C and °F. And the units will ship with the display defaulted to Fahrenheit.

Changing batteries

1. Take out the old batteries. (As show in figure)
2. Insert two new AAA1.5V dry batteries, and pay attention to the polarity. (As show in figure)
3. Attach the back cover of wireless remote control. (As show in figure).

Note: When changing the batteries, do not use old or different batteries, otherwise, it can cause the wireless remote control malfunction.

Note: If the wireless remote control will not be used for a long time, please take the batteries out, so that they won't leak and damage the wireless remote control.

Note: Operate the wireless remote control within its receiving range.

Note: The remote control should be placed at least 1m away from TV set or stereo sound sets.

Note: If the wireless remote control can not operate normally, please take the batteries out, wait 30 seconds and reinsert them. If the remote control still not work, please change the batteries.

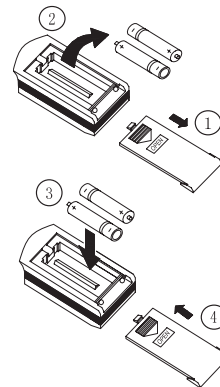

Maintenance

⚠️ WARNING

Hazardous Service Procedures!

The maintenance and troubleshooting procedures recommended in this section of the manual could result in exposure to electrical, mechanical or other potential safety hazards. Always refer to the safety warnings provided throughout this manual concerning these procedures. When possible, disconnect all electrical power including remote disconnect and discharge all energy storing devices such as capacitors before servicing. Follow proper lockout/tagout procedures to ensure the power can not be inadvertently energized. When necessary to work with live electrical components, have a qualified licensed electrician or other individual who has been trained in handling live electrical components perform these tasks. Failure to follow all of the recommended safety warnings provided, could result in death or serious injury.

⚠️ WARNING

Hazardous Voltage!

Disconnect all electric power, including remote disconnects before servicing. Follow proper lockout/tagout procedures to ensure the power can not be inadvertently energized. Failure to disconnect power before servicing could result in death or serious injury.

⚠️ CAUTION

Keep foreign objects away from the fan!

Make sure you or your children do not put objects such as sticks, sand or rocks into the return air or discharge grilles. Failure to follow this safety precaution could result in the fan projecting the object at high speed, which could result in minor or moderate injury.

⚠️ WARNING

Risk of Electrocutation!

Do not apply water directly to the unit for cleaning purposes. Failure to follow this safety precaution could result in electrical shock which could result in death or serious injury.

Cleaning the Front Panel

1. Take off the front panel along the direction of arrows. Lift the front panel up, hold both slots of the front panel and take it out forcibly.

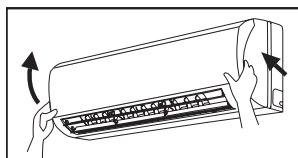

⚠️ WARNING**Fire Hazard!**

Never dry the filters using a fire. Failure to follow this safety precaution could result in the filter catching on fire which could cause minor to moderate injury or property only damage.

Cleaning the Filter

1. The filters can be cleaned with water, but can't with brush or hard things. Dry it in the shade or sun after cleaning, but not by wiping.
2. The healthy filter commonly has its usage lifetime for one year under normal condition.

Reinsert the filters along with the arrow head, then close the front panel.

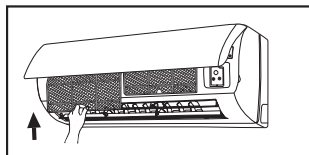
**Check before use**

1. Make sure that nothing obstructs the air outlet and intake vents.

⚠️ WARNING**Ground Wire!**

All field-installed wiring must be completed by qualified personnel. All field-installed wiring must comply with NEC and applicable local codes. Failure to follow this instruction could result in death or serious injuries.

2. Make sure the ground wire is properly connected.
3. Make sure the batteries in the remote control are working; change them if necessary.
4. Check the subbase at the outdoor unit. If damaged, please contact the dealer.

Maintain after use**⚠️ WARNING****Hazardous Voltage!**

Disconnect all electric power, including remote disconnects before servicing. Follow proper lockout/tagout procedures to ensure the power can not be inadvertently energized. Failure to disconnect power before servicing could result in death or serious injury.

1. Clean the filter and indoor and outdoor units' cabinets.
2. Clean and repaint any sign of rust on the outdoor unit to prevent it from spreading.



Troubleshooting

⚠️ WARNING

Hazardous Service Procedures!

The maintenance and troubleshooting procedures recommended in this section of the manual could result in exposure to electrical, mechanical or other potential safety hazards. Always refer to the safety warnings provided throughout this manual concerning these procedures. When possible, disconnect all electrical power including remote disconnect and discharge all energy storing devices such as capacitors before servicing. Follow proper lockout/tagout procedures to ensure the power can not be inadvertently energized. When necessary to work with live electrical components, have a qualified licensed electrician or other individual who has been trained in handling live electrical components perform these tasks. Failure to follow all of the recommended safety warnings provided, could result in death or serious injury.

Problems	Possible causes
Air conditioner does not run upon immediately restart after a stop.	To protect the air conditioner upon immediate restart after a stop, the microcomputer controller will delay the unit for 3 minutes before the air conditioner will run.
Air conditioner blows out bad smell when it is initially started.	* The air conditioner itself has no bad smell. Solution: Clean the air filter. * If the problem persists after cleaning the filters, the air conditioner should be cleaned and serviced by an Authorized Trane dealer)
You may hear "Water Flowing" noise when the air conditioner is running.	When the air conditioner is started, or the compressor is started or stopped during running or the air conditioner is stopped, sometimes you may hear the flowing sound of refrigerant.
Sometimes a thin fog will flow out of the outlet when air conditioner is running under cooling mode.	This might occur when indoor temperature and humidity are high. This is because the indoor air is quickly cooled down. After a period of time, the fog will disappear with the decrease of indoor temperature and humidity.
You may hear a slight crack when the air conditioner is started or stopped.	This is the sound caused by expansion of plastic panel or other parts due to the change of temperature.
The unit can not run	* Has the power been shut down? * Does power plug come loose from the socket? * Is the circuit protection device tripped off or not? * Is voltage higher or lower? (Tested by professionals) * Is the Timer correctly used?
Cooling(Heating) efficiency is not good.	* Is Temp. setting suitable? * Were inlet and outlet vents obstructed? * Is there too much dust accumulated and obstructed the filter? * Are the windows and doors closed? * Did Fan speed set at low speed? * Is there any heat sources in the room?
Wireless remote control is not functioning	* Is it in its receiving range? Or obstructed? * Check and/or replace the batteries. * The wireless remote control is damaged.
Water leakage in the room	* The air humidity is on the high side. * Water overflowing due to blocked drain tube. Call your Authorized Trane dealer. * The connection position of indoor unit drainage pipe is loose.
Water leakage in outdoor unit	* When the unit is running in the COOL mode, moisture from the indoor space will be discharged from the drain pipe. * When the unit is running in the HEAT mode, moisture may drip from the outdoor coil. * When the unit is running in Auto Defrost mode, frost that has formed on the outdoor coil will be thawed.

Problems	Possible causes
Noise is emitted from the indoor unit.	* The sound of the fan or compressor relay switching on or off. * When the defrost mode is starting or stopping, the sound of refrigerant flow changing direction may be heard.
No air is being delivered from the indoor unit	* In the HEAT mode, if the temperature of the indoor coil is very low, the fan will stop for up to 3 minutes to prevent the delivery of cold air. * In the HEAT mode, frost may accumulate on the outdoor coil due to low outdoor temperature and/or high outdoor humidity. The unit will automatically switch to defrost mode, and the indoor unit will stop blowing air for approximately 8-10 minutes. During the defrost cycle, moisture may flow from the outdoor unit and steam may be observed. * In the dehumidifying mode, the indoor fan occasionally stops to avoid condensing water to be re-vaporized.
Moisture on the guide louver	If the unit is running for extended periods of time in high humidity conditions, moisture may accumulate on the guide louver.

When one of the following situations occur, please unplug the unit and contact a Trane dealer immediately:

- There is harsh sound during operation
- The terrible odors emitted during operation
- Water is leaking in the room
- Circuit breaker trips frequently
- Water or other liquid is splashed into the unit
- There is an abnormal heat in power supply cord and power plug.



Operation

Emergency Operation

If the wireless remote is lost or damaged, the system can be operated using the manual switch or code switch. The system will run in Auto Run mode, and will not change the temperature setting nor the fan speed.

The manual switch can be operated as follows:

To operate the unit, press the AUTO/STOP button once and the unit will enter into AUTO RUN mode. The microcomputer will select the (COOL, HEAT, FAN) mode automatically to maintain optimum room comfort.

To stop the unit from operating, press the AUTO/STOP button once and the unit will shut down.

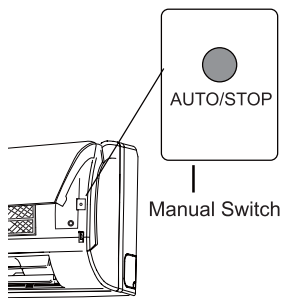

Working principle of cooling mode

Principle:

The air conditioner absorbs heat from the room and uses refrigerant to transfer the heat energy to the outdoor unit where it is discharged to the outdoor air. Total cooling capacity will increase or decrease based on outdoor ambient temperature.

Anti-freezing protection

If the unit is running in the COOL mode, and the indoor coil temperature drops due to low indoor air temperature conditions, the microcomputer will stop the compressor in order to protect the unit.

Working principle of heating mode

Principle:

- The air conditioner absorbs heat from the outdoor air and uses refrigerant to transfer the heat energy to the indoor unit where it is discharged into the room. Total heating capacity will increase or decrease based on outdoor ambient temperature.
- If the outdoor temperature should drop to extremely low temperatures, other methods of heating and ventilating may be necessary.

Defrosting:

When the outdoor temperature is low and/or with high humidity, frost may form on the outdoor coil, reducing the ability of the unit to transfer energy. The unit will enter Auto Defrost mode and the heating mode will be discontinued for 8-10 minutes.

- During the Auto Defrost cycle, the fan motors of the indoor and outdoor units will stop running.
- During the Auto Defrost cycle, the indoor indicator flashes, and moisture may flow from the outdoor unit and steam may be observed.

When the defrost cycle is complete, the unit will return to HEAT mode

Anti-freezing protection:

In the HEAT mode, if the indoor coil has not achieved a certain temperature, the indoor fan will not operate for approximately 3 minutes. This may occur when:

1. Initial start-up of HEAT cycle
2. Immediately on completion of an Auto Defrost Cycle
3. Heating under extremely low indoor temperatures



www.trane.com

For more information, contact your local Trane office or e-mail us at comfort@trane.com

Literature Order Number MS-SVU42A-EN

Date April 2010

Supersedes New

Trane has a policy of continuous product and product data improvement and reserves the right to change design and specifications without notice.

66129904985