

INSTALLATION INSTRUCTIONS

R-410A Ductless Split System Air Conditioner and Heat Pump

MODELS: DLC4(A/H)–Outdoor, DLF4(A/H)–Indoor
SIZES: 9K, 12K, 18K, 24K, 30K, and 36K

NOTE: Read the entire instruction manual before starting the installation.

TABLE OF CONTENTS

	PAGE
PARTS LIST	1
SAFETY CONSIDERATIONS	1
GENERAL	2
SYSTEM REQUIREMENTS	2
ELECTRICAL TABLES	2
DIMENSIONS	3
CLEARANCES	7
INSTALLATION	8
INDOOR UNIT INSTALLATION	8
Install Mounting Plate	8
Drill Hole in Wall for Connecting Piping, Drain & Wiring	9
OUTDOOR UNIT INSTALLATION	9
Piping and Drainage Connections	9
Control and Power Wiring from Outdoor Unit	10
AIR PURGING AND LEAKAGE TEST	11
START-UP	12
OPERATION TEST	12
AIR FILTER INSTALLATION	12
CONNECTION DIAGRAMS	13
TROUBLESHOOTING	14

The following parts are included in your indoor unit. Please contact your dealer if any parts are damaged or missing.

Parts	Qty.
Mounting Plate	1
Remote Control	1
Remote Control Holder	1
Mounting Hardware	7
Battery (1.5V)	2

SAFETY CONSIDERATIONS

Installing, starting up, and servicing air-conditioning equipment can be hazardous due to system pressures, electrical components, and equipment location (roofs, elevated structures, etc.).

Only trained, qualified installers and service mechanics should install, start-up, and service this equipment.

Untrained personnel can perform basic maintenance functions such as cleaning coils. All other operations should be performed by trained service personnel.

When working on the equipment, observe precautions in the literature and on tags, stickers, and labels attached to the equipment.

Follow all safety codes. Wear safety glasses and work gloves. Keep quenching cloth and fire extinguisher nearby when brazing. Use care in handling, rigging, and setting bulky equipment.

Read these instructions thoroughly and follow all warnings or cautions included in literature and attached to the unit. Consult local building codes and National Electrical Code (NEC) for special requirements. In Canada, refer to current editions of the Canadian Electrical Code, CSA 22.1.

Recognize safety information. This is the safety-alert symbol . When you see this symbol on the unit and in instructions or manuals, be alert to the potential for personal injury. Understand these signal words: DANGER, WARNING, and CAUTION. These words are used with the safety-alert symbol. DANGER identifies the most serious hazards which **will** result in severe personal injury or death. WARNING signifies hazards which **could** result in personal injury or death. CAUTION is used to identify unsafe practices which **may** result in minor personal injury or product and property damage. NOTE is used to highlight suggestions which **will** result in enhanced installation, reliability, or operation.

 **WARNING**

ELECTRICAL SHOCK HAZARD

Failure to follow this warning could result in personal injury or death.

Before installing, modifying, or servicing system, main electrical disconnect switch must be in the OFF position. There may be more than 1 disconnect switch. Lock out and tag switch with a suitable warning label.

 **CAUTION**

EQUIPMENT DAMAGE HAZARD

Failure to follow this caution may result in equipment damage or improper operation.

Do not bury more than 36 in. (914 mm) of refrigerant pipe in the ground. If any section of pipe is buried, there must be a 6 in. (152 mm) vertical rise to the valve connections on the outdoor units. If more than the recommended length is buried, refrigerant may migrate to the cooler buried section during extended periods of system shutdown. This causes refrigerant slugging and could possibly damage the compressor at start-up.

GENERAL

These instructions cover the installation, start-up and servicing of DLC4(A/H) outdoor and DLF4(A/H) indoor units ductless systems.

SYSTEM REQUIREMENTS

Allow sufficient space for airflow and servicing unit. See Figure. 1 for minimum required distances between unit and walls or ceilings.

Piping

IMPORTANT: Both refrigerant lines must be insulated separately.

- Minimum refrigerant line length between the indoor and outdoor units is 10 ft. (3 m).

- The following maximum lengths are allowed:

REFRIGERANT LINE LENGTHS ft. (m)			
Unit Size	Max Line Length	Max Elevation (ID over OD)	Max Elevation (OD over ID)
9K	50 (15)	33 (10)	33 (10)
12K	66 (20)	33 (10)	33 (10)
18, 24K	82 (25)	33 (10)	33 (10)
30, 36K	98 (30)	33 (10)	33 (10)

- The following are the piping sizes.

Unit Size	PIPE SIZES	
	Mix Phase	Vapor
9, 12K	1/4"	3/8"
18K	1/4"	1/2"
24, 30, 36K	1/4"	5/8"

R-410A Refrigerant Charge Table

Unit Size	Charge Amount * LBS (kg)		Additional Charge Amount ** oz/ft (g/m)		Metering Device ***
	Cool Only	Heat Pump	Cool Only	Heat Pump	
9K	2.65 (1.20)	2.65 (1.20)	0.16 (15)	0.22 (20)	EXV
12K	2.86 (1.30)	2.86 (1.30)	0.16 (15)	0.22 (20)	EXV
18K	3.09 (1.40)	3.09 (1.40)	0.16 (15)	0.22 (20)	EXV
24K	3.53 (1.60)	3.53 (1.60)	0.16 (15)	0.54 (50)	EXV
30K	-----	5.30 (2.40)	-----	0.54 (50)	EXV
36K	5.30 (2.40)	5.73 (2.60)	0.54 (50)	0.54 (50)	EXV

* Charge is for piping that runs up to 25 ft. (7.6 m)

** For piping runs greater than 25 ft. (7.6 m), add this amount of charge per foot of extra piping, up to the allowable length, specified in the above table.

*** EXV – Electronic Expansion Device

Connecting (Power and Control Cable)

- The main power is supplied to the outdoor unit. The field supplied connecting cable from the outdoor unit to indoor unit consists of four wires and provides the power for the indoor unit as well as the communication signal and ground between the outdoor and indoor unit. Two wires are high voltage AC power, one is low voltage DC signal and one is a ground wire.
- Consult local building codes, NEC (National Electrical Code) or CEC (Canadian Electrical Code) for special requirements.

⚠ CAUTION

EQUIPMENT DAMAGE HAZARD

Failure to follow this caution may result in equipment damage or improper operation.

- Be sure to comply with local codes while running wire from indoor unit to outdoor unit.
- Every wire must be connected firmly. Loose wiring may cause terminal to overheat or result in unit malfunction. A fire hazard may also exist. Therefore, be sure all wiring is tightly connected.
- No wire should be allowed to touch refrigerant tubing, compressor or any moving parts.
- Disconnecting means must be provided and shall be located within sight and readily accessible from the air conditioner.
- Connecting cable with conduit shall be routed through hole in the conduit panel.

⚠ CAUTION

EQUIPMENT DAMAGE HAZARD

Failure to follow this caution may result in equipment damage or improper operation.

- Based on the MCA's in the electrical table, only 14 AWG wire should be used.
- Use copper conductors only with a minimum 300 volt rating and 2/64 inch thick insulation.

Electrical Data Table

Unit Size	System Voltage Volts-Ph.-Freq.	Operating Voltage (Min/Max)	Compressor		Outdoor Fan		Indoor Fan				MCA	Max Fuse/ CB Amps (MOCP)
			RLA	LRA	FLA	Output Watts	Volts	FLA	HP	Output Watts		
9K	115-1-60	103/127	12.2	33.0	0.17	30	115 V-AC	0.38	0.056	20	16	25
12K	115-1-60	103/127	12.4	33.0	0.17	30	115 V-AC	0.38	0.056	20	16	25
12K	208/230-1-60	187/253	5.3	13.8	0.14	30	208/230 V-AC	0.20	0.056	20	10	15
18K	208/230-1-60	187/253	9.4	13.8	0.37	60	208/230 V-AC	0.21	0.075	20	16	20
24K	208/230-1-60	187/253	10.5	18.5	1.10	90	176-375 V-DC	0.24	0.068	60	16	20
30K	208/230-1-60	187/253	12.0	40.0	0.45	100	208/230 V-AC	0.40	0.106	40	15	25
36K	208/230-1-60	187/253	13.5	67.0	0.73	170	208/230 V-AC	0.47	0.114	60	17	30

4MXW6518A10N0B

MODEL NOMENCLATURE

MODEL SERIES	D	L	C	4	A	V	0	9	J	1	A
Position Number	1	2	3	4	5	6	7	8	9	10	11
DLC = Outdoor DLF = Indoor	Outdoor/Indoor										
4AV = AC Outdoor 4AC = AC Indoor 4HV = HP Outdoor 4HH = HP Indoor	Type										
09 = 9k BTU 12 = 12k BTU 18 = 18k BTU 24 = 24k BTU 30 = 30k BTU 36 = 36k BTU							Size				
J = 115-1-60 K = 208/230-1-60									Voltage		
1A											Factory Designation

DIMENSIONS – INDOOR

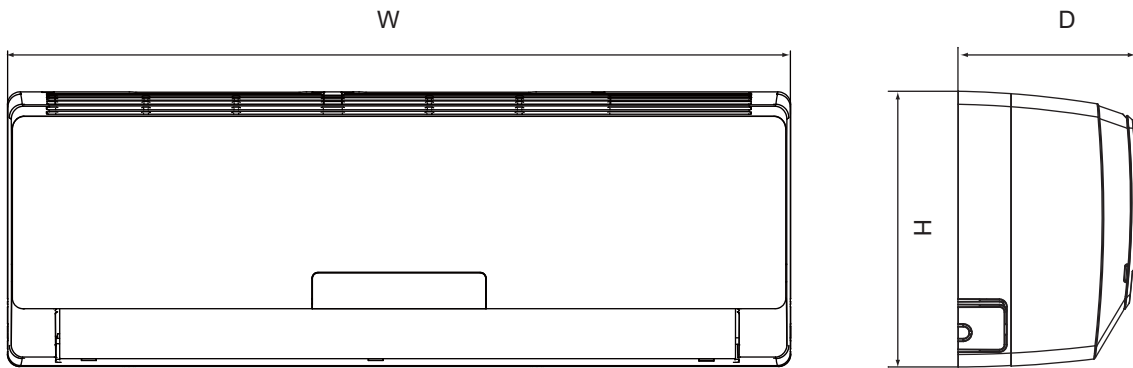

A12377

Unit Size	W In. (mm)	H In. (mm)	D In. (mm)	Net Operating Weight Lbs. (Kg)
9k	33.3 (846)	10.7 (272)	7.1 (180)	29 (13)
12k	33.3 (846)	10.7 (272)	7.1 (180)	29 (13)
18k	37.0 (940)	11.7 (297)	7.9 (201)	29 (13)
24k	39.7 (1008)	12.4 (315)	8.6 (218)	35 (16)
30k	53.1 (1349)	12.8 (325)	10.0 (54)	44.1 (20.0)
36k	53.1 (1349)	12.8 (325)	10.0 (54)	44.1 (20.0)

DIMENSIONS – OUTDOOR

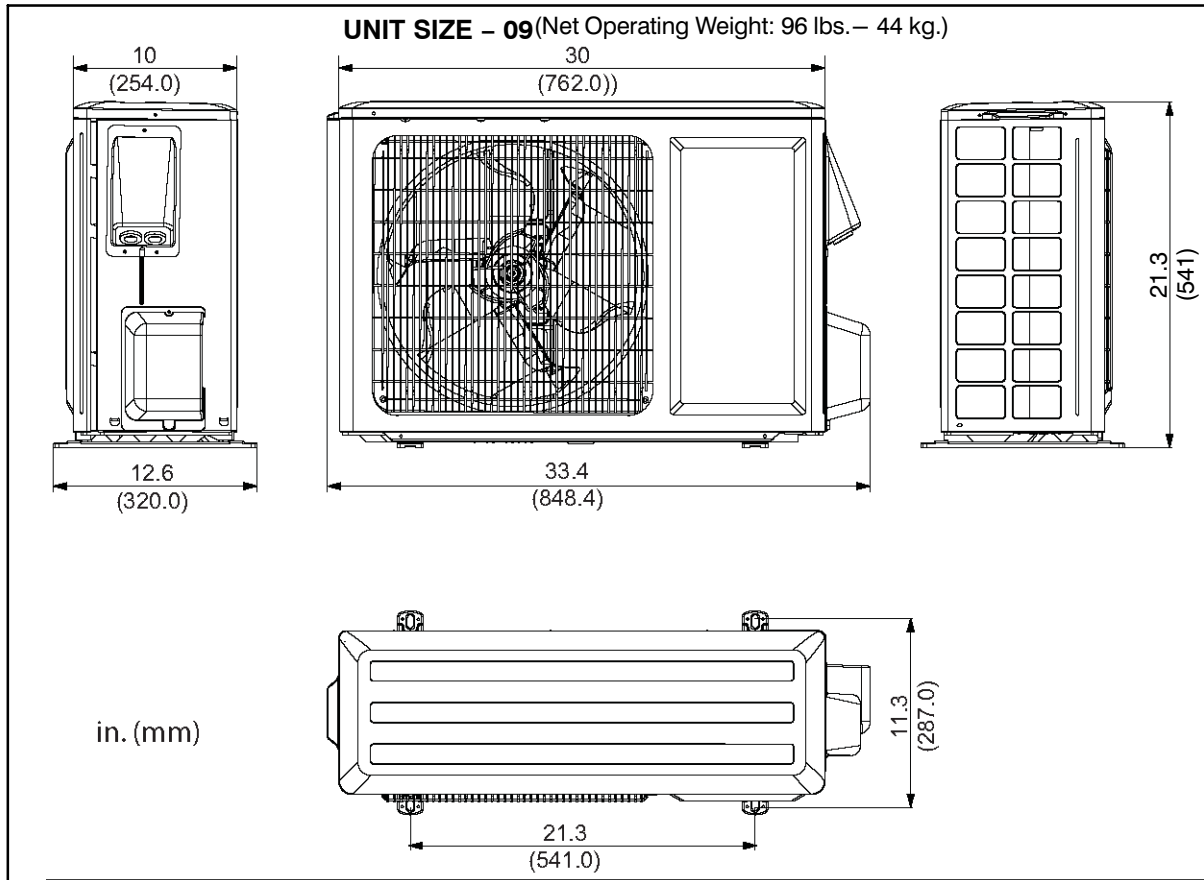

A12380

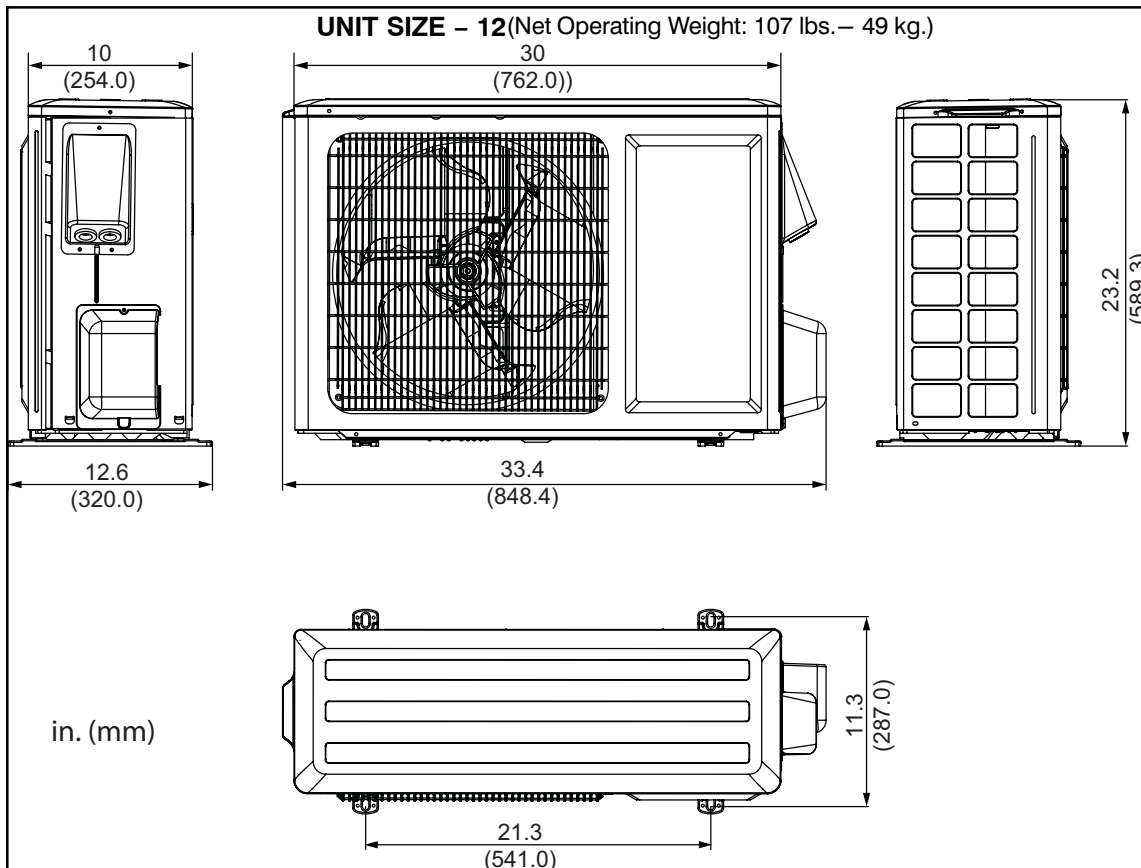

A12381

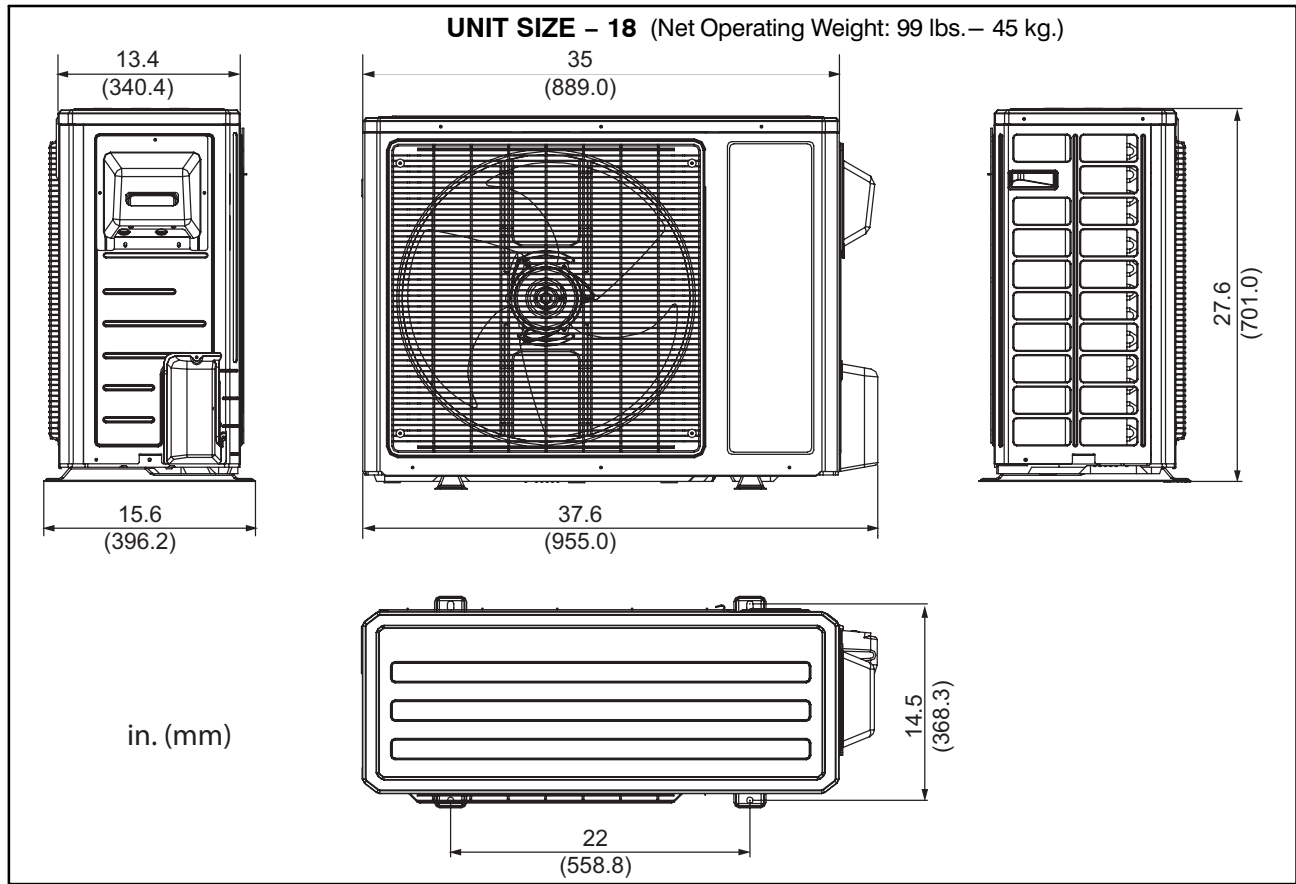

A12382

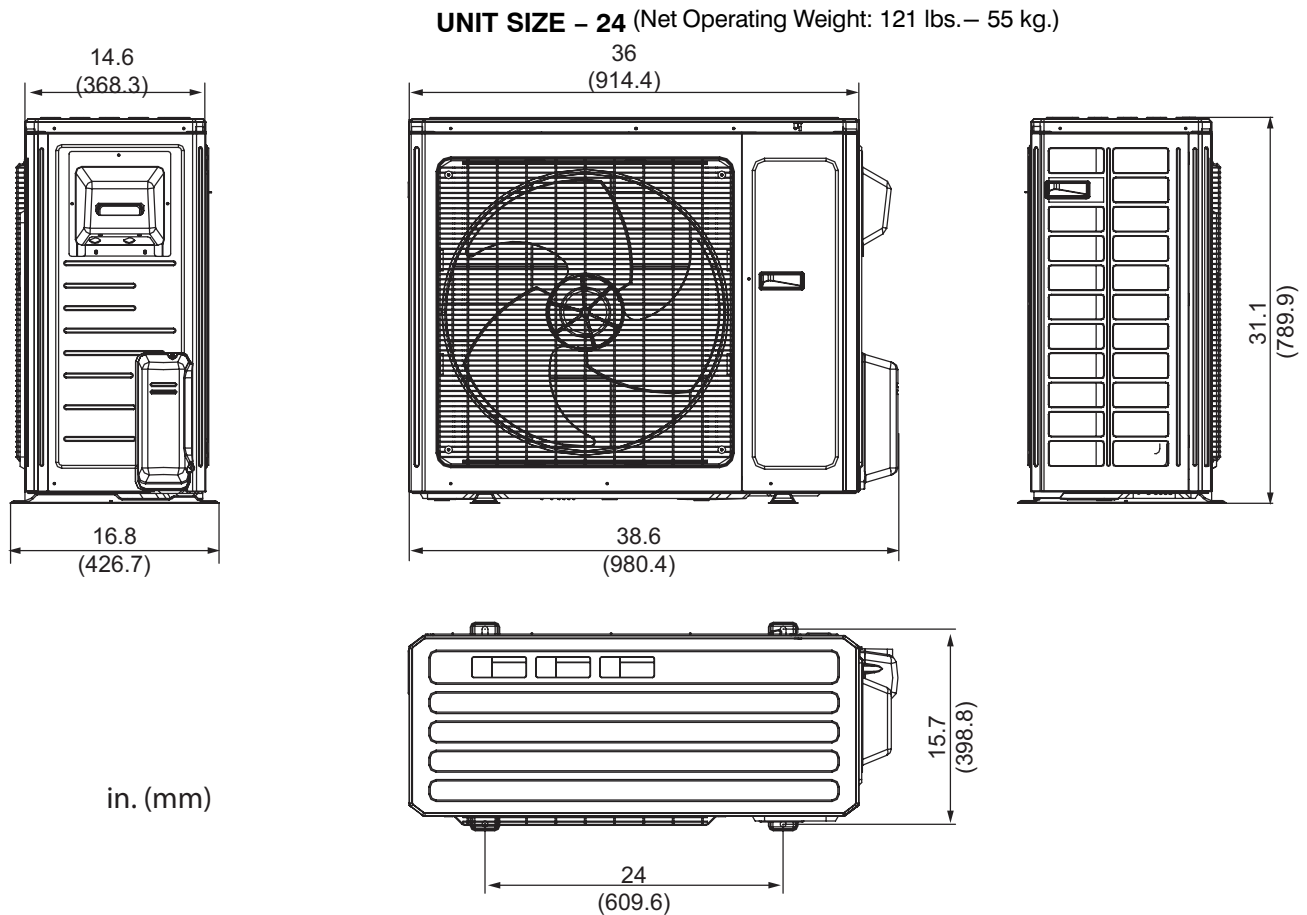

A12383

UNIT SIZE – 30 (Net Operating Weight: 154 lbs – 70 kg.)
36 (Net Operating Weight: 161 lbs – 73 kg.)

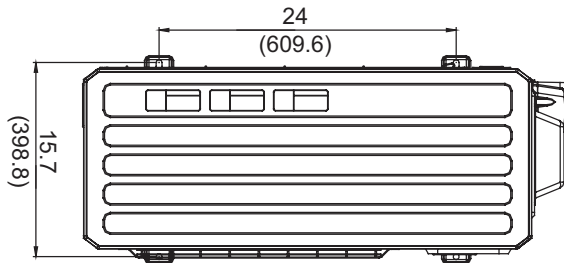
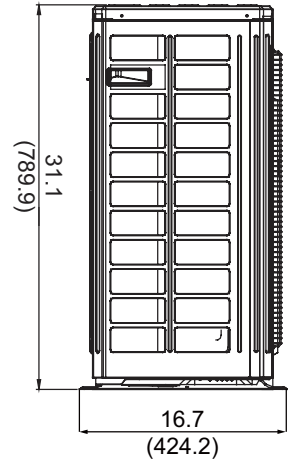
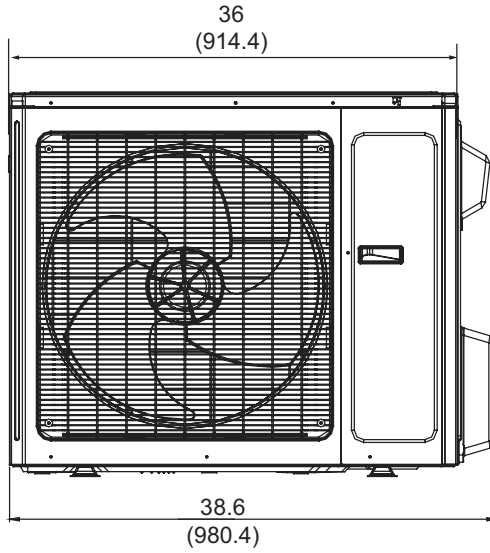
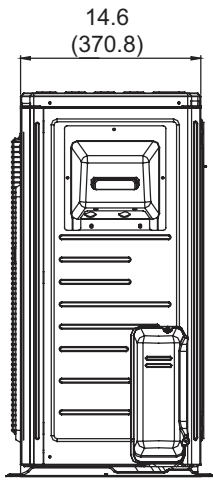

in. (mm)

A12379

CLEARANCES

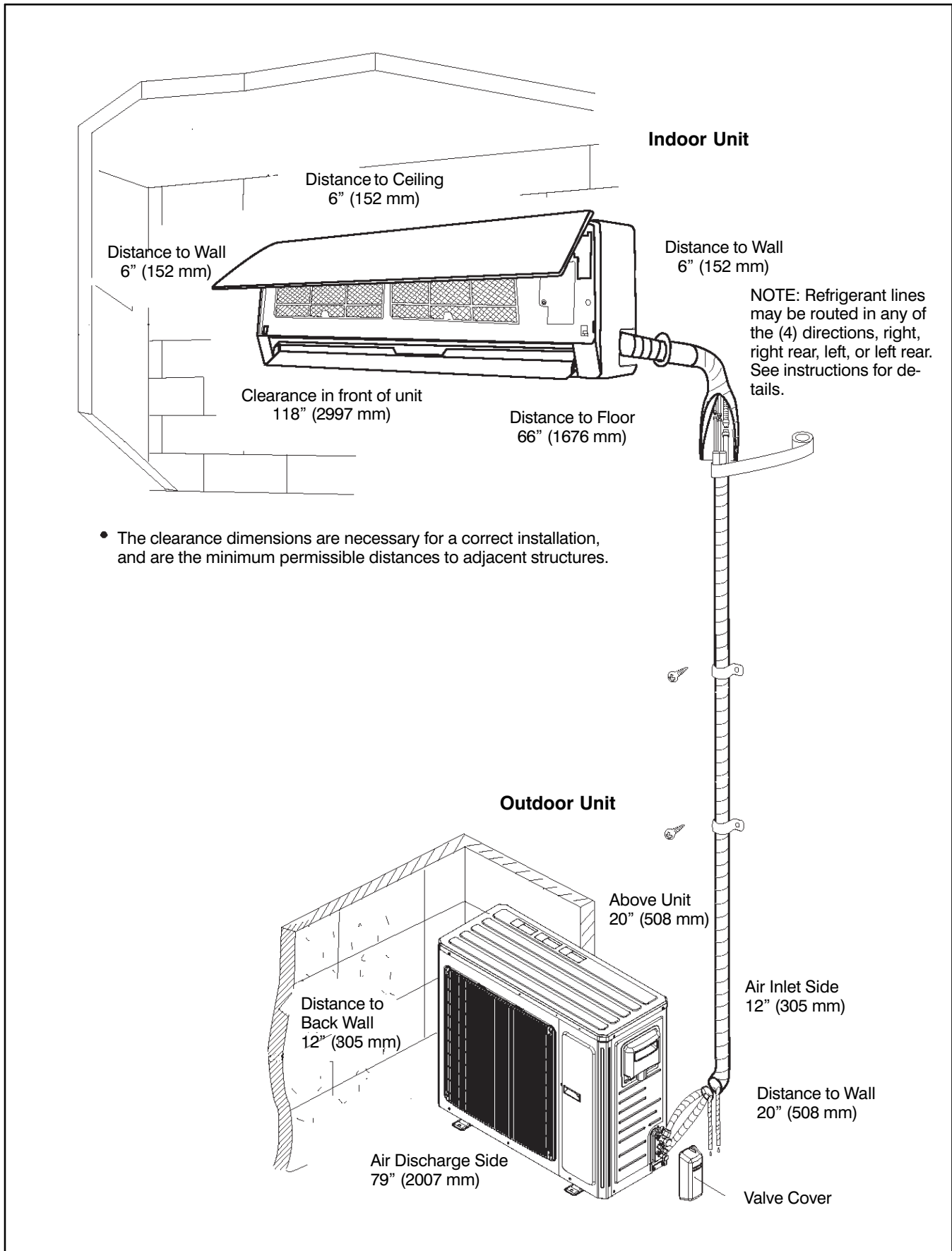

A07891

Figure 1 – Unit clearance

INSTALLATION GUIDE

Ideal installation locations include:

Indoor Unit

- A location where there are no obstacles near inlet and outlet area.
- A location which can bear the weight of indoor unit.
- Do not install indoor units near a direct source of heat such as direct sunlight or a heating appliance.
- A location which provides appropriate clearances as outlined in Figure 1. Be sure to leave enough Distance to allow access for routine maintenance. The installation site should be 66 in. (1676mm) or more above the floor.
- Select a place away from potential electronic interference.
- Select a place where the filter can be removed easily.

Outdoor Unit

- A location which is convenient to installation and not exposed to strong wind.
- A location which can bear the weight of outdoor unit and where the outdoor unit can be mounted in a level position.
- A location which provides appropriate clearances as outlined in Figure 1.
- Do not install the indoor or outdoor units in a location with special environmental conditions.
- Make sure that the outdoor unit is installed in accordance with the installation instructions, and is convenient for maintenance and repair.
- See the refrigerant piping table for the maximum height difference between indoor and outdoor units, and the maximum length of the connecting tubing.

INDOOR UNIT INSTALLATION

INSTALL MOUNTING PLATE

1. Carefully remove the mounting plate from the unit box.
2. The mounting plate should be located horizontally and level on the wall. All minimum spacings shown in Figure 1 through Figure 3 should be maintained.
3. If the wall is block, brick, concrete or similar material, drill .2" (5 mm) diameter holes and insert anchors for the appropriate mounting screws.
4. Attach the mounting plate to the wall.

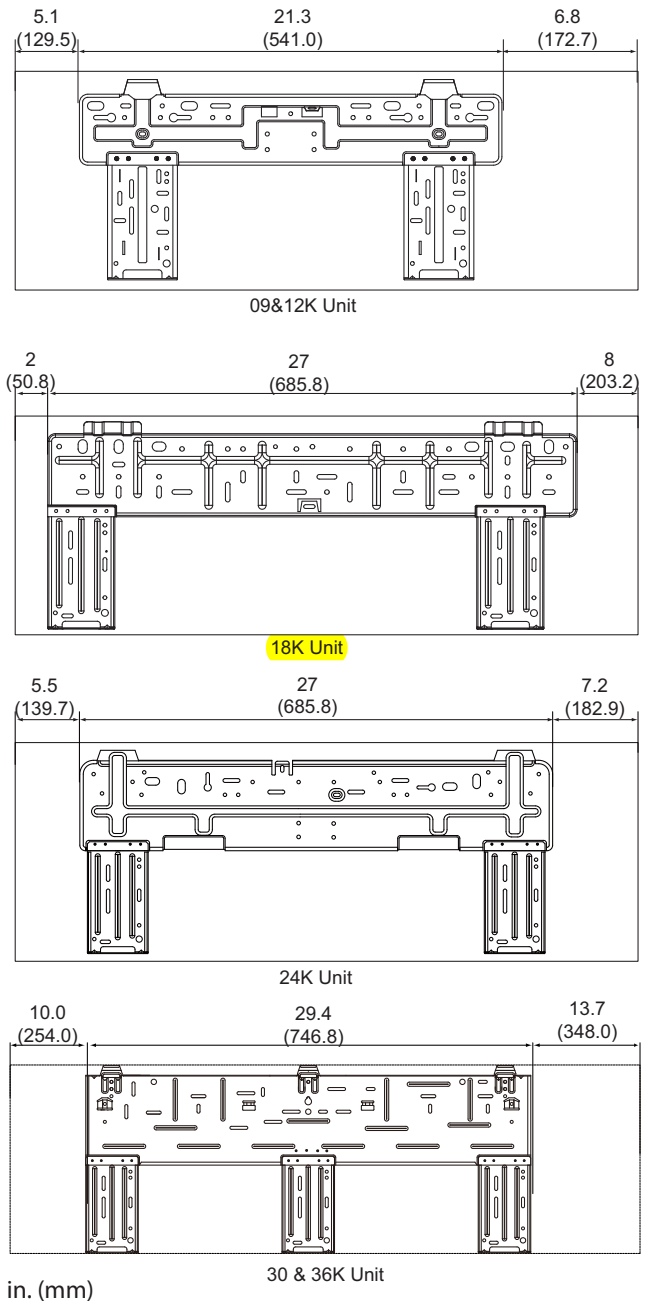

Figure 2 – Mounting Plate Spacing

A12378

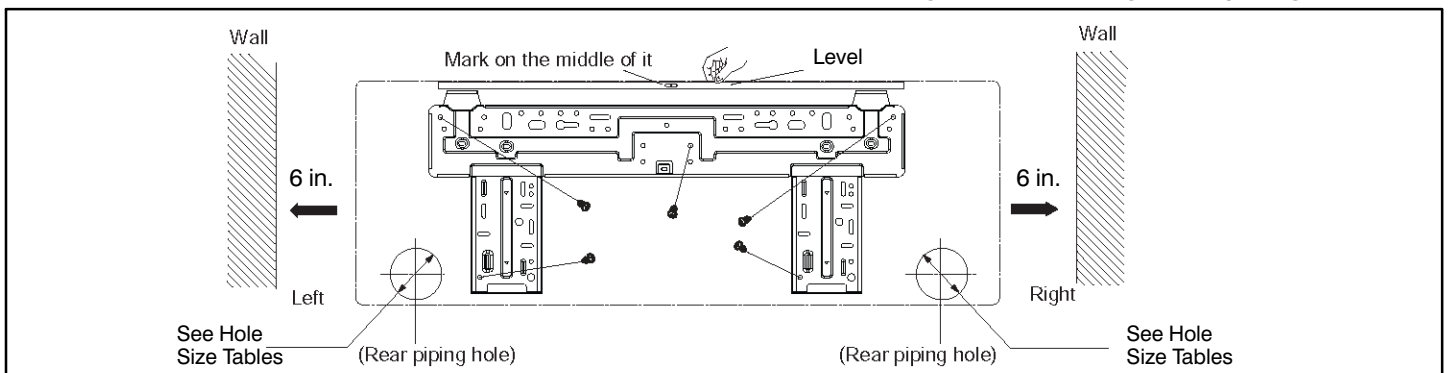

Figure 3 – Install Mounting Plate

DRILL HOLE IN WALL FOR INTERCONNECTING PIPING, DRAIN, AND WIRING

Refrigerant Line Routing

The refrigerant lines may be routed in any of the four directions shown in Figure 4.

For maximum serviceability, it is recommended to have refrigerant line flare connections and the drain connection on the outside of the wall that the fan coil is mounted on.

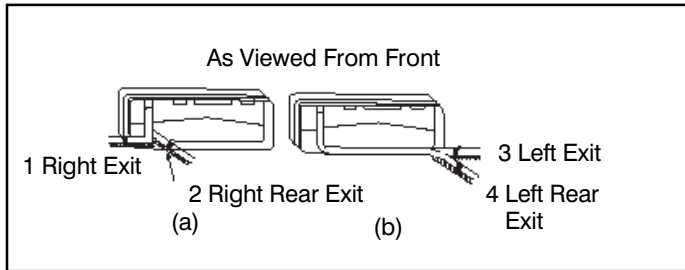

Figure 4 – Refrigerant Line Routing

A08281

1. Determine pipe hole position using the mounting plate as a template. Drill pipe hole diameter per chart below. The outside pipe hole is 1/2 in. (13mm) min. Lower than inside pipe hole, so it slants slightly downward. See figure 5.

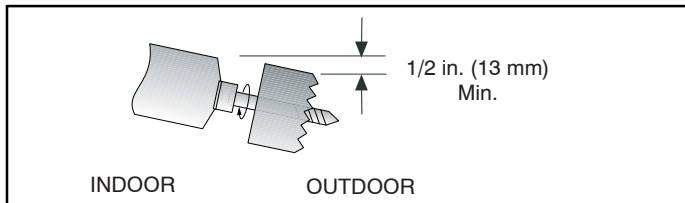

Figure 5 – Drill Holes

A07371

Hole SIZES	
Unit Size	Hole Diameter, In. (mm)
9K, 12K, 18K	2.2 (56)
24K, 30K, 36K	2.8 (71)

If piping is going through the right or left side:

1. Use a small saw blade to carefully remove the corresponding plastic covering on side panel and drill the appropriate size hole where the pipe is going through the wall. See table above.
2. Remove knockout 1 to run just the wiring. Remove knockout 1 and 2 or knockout 1, 2, and 3 if running both piping and wiring through the side of the unit. See Figure 11.

NOTE: If required, a condensate pump is available for the application.

OUTDOOR UNIT INSTALLATION

1. Use a rigid base to support unit in a level position.
2. Locate outdoor unit and connect piping and wiring.

⚠ CAUTION

EQUIPMENT DAMAGE HAZARD

Failure to follow this caution may result in equipment damage or improper operation.

Excessive torque can break flare nut depending on installation conditions.

Piping Connections to Outdoor Unit

IMPORTANT: Use refrigeration grade tubing ONLY. No other type of tubing may be used. Use of other types of tubing will void manufacturer’s warranty.

Make sure there is enough piping to cover the required length between the outdoor and indoor unit.

Piping Guide:

- Do not open service valves or remove protective caps from tubing ends until all the connections are made.
- Bend tubing with bending tools to avoid kinks and flat spots.
- Keep the tubing free of dirt, sand, moisture, and other contaminants to avoid damaging the refrigerant system.
- Avoid sags in the suction line to prevent the formation of oil traps. Insulate each tube with minimum 3/8" (10mm) wall thermal pipe insulation. Inserting the tubing into the insulation before making the connections will save time and improve installation quality.
 1. Remove service valve cover if provided with unit.
 2. Cut tubing with tubing cutter.
 3. Install correct size flare nut onto tubing and make flare connection.
 4. Apply a small amount of refrigerant oil to the flare connection on the tubing.
 5. Properly align tubing end with service valve.
 6. Tighten flare nut and finish installation using two wrenches as shown in figure below.

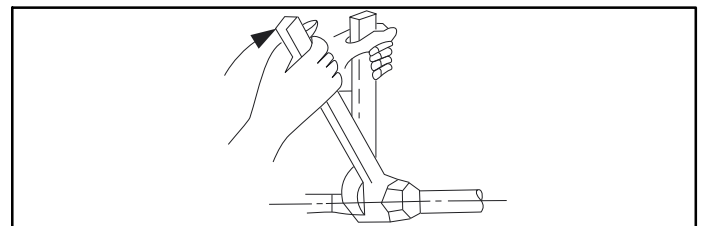

Figure 6 – Tighten Flare Nut

A07354

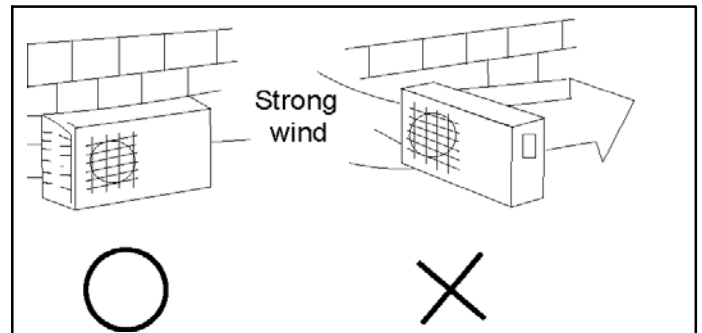

Figure 7 – High Wind Installation

A07350

Outdoor Unit Wiring Connections

1. Mount outdoor power disconnect.
2. Run power wiring from main box to disconnect per NEC and local codes. Set outdoor unit in place.
3. Remove field wiring cover from unit by removing screws. See Figure 8.
4. Connect conduit to the conduit panel on sizes 9K, 12K and 18k. See Figure 8.
5. Properly connect both power supply and control lines to terminal block per the connection diagram. See Figure 18.
6. Ground unit in accordance with NEC and local electrical codes.
7. Use lock nuts to secure conduit.

8. Reinstall field wiring cover.

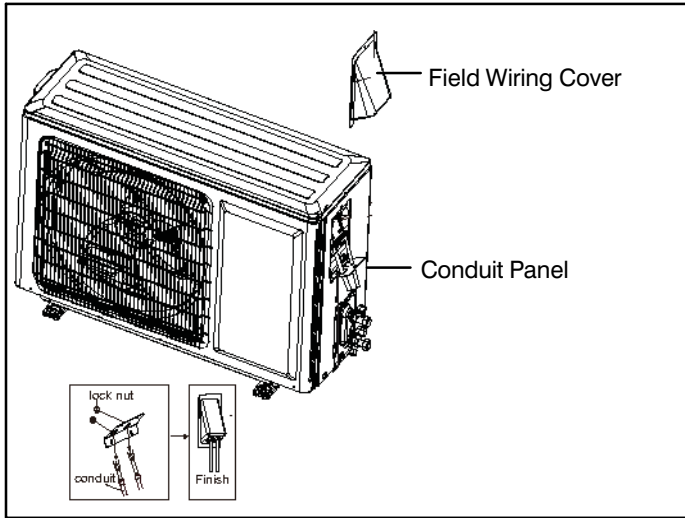

Figure 8 – Install Outdoor Unit

A12411



CAUTION

EQUIPMENT DAMAGE HAZARD

Failure to follow this caution may result in equipment damage or improper operation.

- Be sure to comply with local codes while running wire from indoor unit to outdoor unit.
- Every wire must be connected firmly. Loose wiring may cause terminal to overheat or result in unit malfunction. A fire hazard may also exist. Therefore, be sure all wiring is tightly connected.
- No wire should be allowed to touch refrigerant tubing, compressor or any moving parts.
- Disconnecting means must be provided and shall be located within sight and readily accessible from the air conditioner.
- Connecting cable with conduit shall be routed through hole in the conduit panel.

INSTALL ALL POWER, INTERCONNECTING WIRING, AND PIPING TO OUTDOOR UNIT

1. Run interconnecting piping and wiring from outdoor unit to indoor unit.
2. Pass interconnecting cable through hole in wall (outside to inside).
3. Lift indoor unit into position and route piping and drain through hole in wall (inside to outside). Fit interconnecting wiring into back side of indoor unit.
4. Hang indoor unit on upper hooks of wall mounting plate, as shown in Figure 9 and Figure 12.

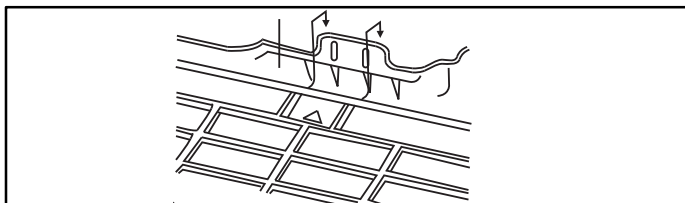
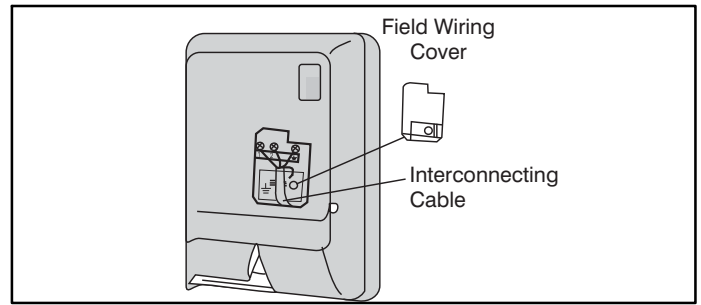

Figure 9 – Hanging Indoor Unit

A08283

5. Open front cover of indoor unit and remove field wiring terminal block cover. See Figure 10.



A08279

Figure 10 – Field Wiring Cover

6. Pull interconnecting wire up from back of indoor unit and position in close to the terminal block on indoor unit.
7. Push bottom of indoor unit onto mounting plate to complete wall mount.
8. Connect wiring from outdoor unit per connection diagram. See Figure 18.

NOTE: Polarity of power wires must match original connection on outdoor unit.

9. Replace field wiring cover and close front cover of indoor unit.
10. Connect refrigerant piping and drain line outside of indoor unit. Refer to Figure 6 for proper installation of flare connections. Complete pipe insulation at flare connection then fasten piping and wiring to the wall as required. Completely seal the hole in the wall.

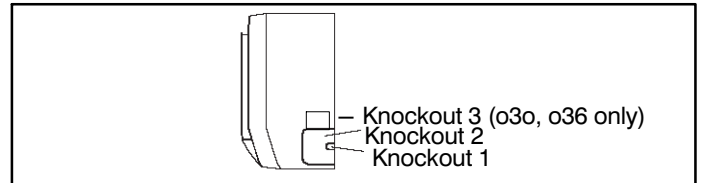

A12410

Figure 11 – Remove Knockouts

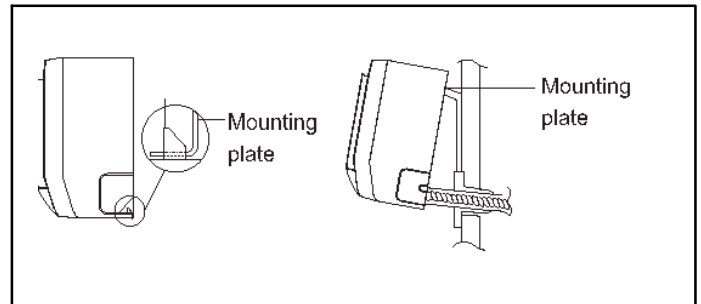

A12408

Figure 12 – Hang Indoor Unit

⚠ CAUTION

UNIT DAMAGE HAZARD

Failure to follow this caution may result in equipment damage or improper operation.

Never use the system compressor as a vacuum pump.

Refrigerant tubes and indoor coil should be evacuated using the recommended deep vacuum method of 500 microns. The alternate triple evacuation method may be used if the procedure outlined below is followed. Always break a vacuum with dry nitrogen.

SYSTEM VACUUM AND CHARGE

Using Vacuum Pump

1. Completely tighten flare nuts A, B, C, D, connect manifold gage charge hose to a charge port of the low side service valve. (See Fig. 13.)
2. Connect charge hose to vacuum pump.
3. Fully open the low side of manifold gage. (See Fig. 14)
4. Start vacuum pump
5. Evacuate using either deep vacuum or triple evacuation method.
6. After evacuation is complete, fully close the low side of manifold gage and stop operation of vacuum pump.
7. The factory charge contained in the outdoor unit is good for up to 25 ft. (8 m) of line length. For refrigerant lines longer than 25 ft (8 m), add 0.1 oz. per foot of extra piping up to the maximum allowable length.
8. Disconnect charge hose from charge connection of the low side service valve.
9. Fully open service valves B and A.
10. Securely tighten caps of service valves.

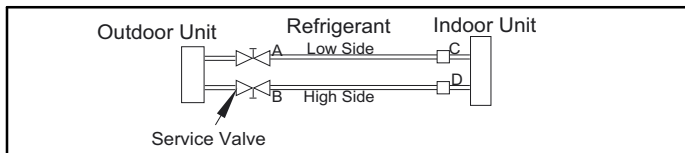

Figure 13 – Service Valve

A07360

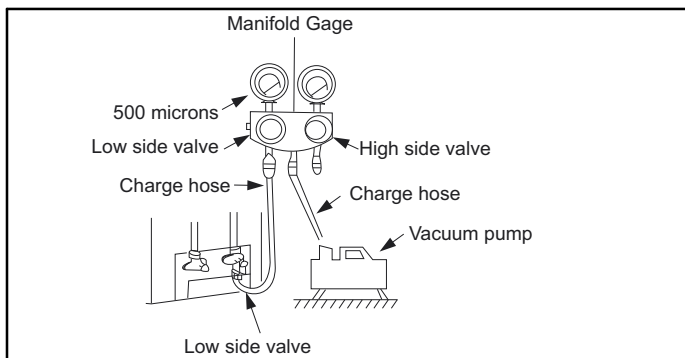
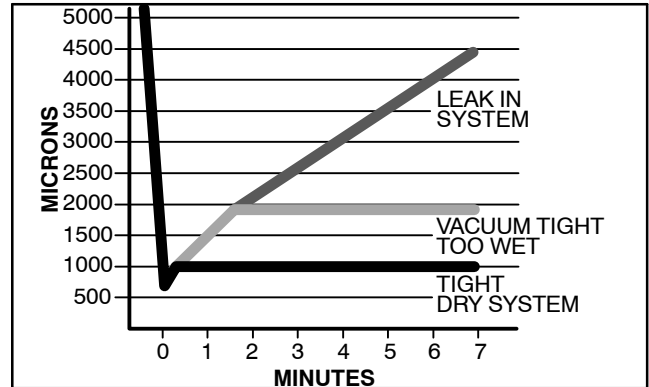

Figure 14 – Manifold

A07361

Deep Vacuum Method

The deep vacuum method requires a vacuum pump capable of pulling a vacuum of 500 microns and a vacuum gage capable of accurately measuring this vacuum depth. The deep vacuum method is the most positive way of assuring a system is free of air and liquid water. (See Fig. 15)



A95424

Figure 15 – Deep Vacuum Graph

Triple Evacuation Method

The triple evacuation method should only be used when vacuum pump is only capable of pumping down to 28 in. of mercury vacuum and system does not contain any liquid water. Refer to Fig. 16 and proceed as follows:

1. Pump system down to 28 in. of mercury and allow pump to continue operating for an additional 15 minutes.
2. Close service valves and shut off vacuum pump.
3. Connect a nitrogen cylinder and regulator to system and open until system pressure is 2 psig.
4. Close service valve and allow system to stand for 1 hr. During this time, dry nitrogen will be able to diffuse throughout the system absorbing moisture.
5. Repeat this procedure as indicated in Fig. 16. System will then be free of any contaminants and water vapor.

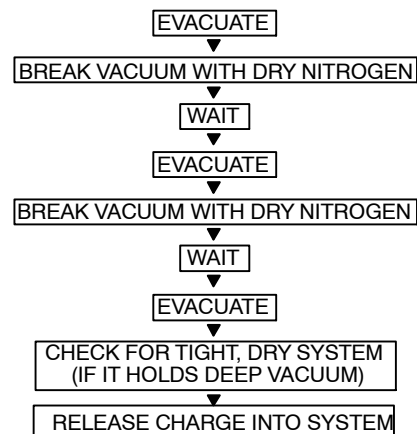

A95425

Figure 16 – Triple Evacuation Method

Final Tubing Check

IMPORTANT: Check to be certain factory tubing on both indoor and outdoor unit has not shifted during shipment. Ensure tubes are not rubbing against each other or any sheet metal. Pay close attention to feeder tubes, making sure wire ties on feeder tubes are secure and tight.

START-UP

Test Operation

Perform test operation after completing gas leak and electrical safety check.

1. Push the "ON/OFF" button on Remote Control to begin testing.

NOTE: A protection feature prevents the air conditioner from being activated for approximately 3 minutes.

2. Push MODE button, select COOLING, HEATING, FAN mode to check if all functions work correctly.

SYSTEM CHECKS

1. Conceal the tubing where possible.
2. Make sure that the drain tube slopes downward along its entire length.
3. Ensure all tubing and connections are properly insulated.
4. Fasten tubes to the outside wall, when possible.
5. Seal the hole through which the cables and tubing pass.

INDOOR UNIT

1. Do all Remote Control buttons function properly?
2. Do the display panel lights work properly?
3. Does the air deflection louver function properly?
4. Does the drain work?

OUTDOOR UNIT

1. Are there unusual noises or vibrations during operation?

Explain Following Items To Customer With The Aid Of The Owner's Manual:

1. How to turn air conditioner on and off; selecting COOLING, HEATING and other operating modes; setting a desired temperature; setting the timer to automatically start and stop air conditioner operation; and all other features of the Remote Control and display panel.
2. How to remove and clean the air filter.
3. How to set air deflection louver.
4. Explain care and maintenance.
5. Present the Owner's Manual and installation instructions to customer.

INSTALLATION AND MAINTENANCE OF FILTER

INSTALLATION OF FILTER

1. Grasp the front panel by its two ends and lift the panel and then remove the air filter.
2. Install a clean air filter along the arrow direction and then close the panel.

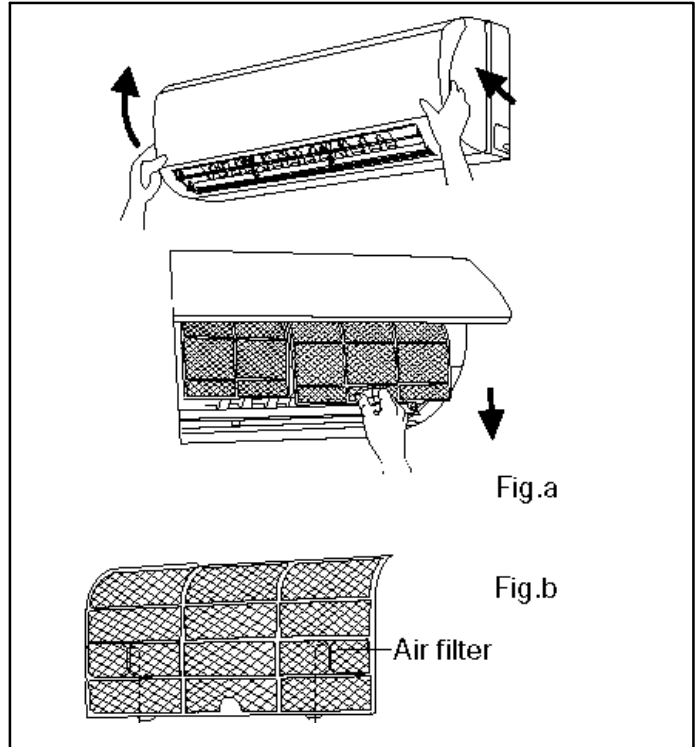

Figure 17 – Install Air Filter

OUTDOOR CONDENSATE DRAINAGE (HEAT PUMP ONLY)

During heating operation, the condensate and defrosting water should be drained out reliably through the drain hose. Install the outdoor drain connector in a 9.8" diameter hole on the base plate and attach the drain hose to the connector so that the water formed in the outdoor unit can be drained out. Plug the hole when finished.

WIRING DIAGRAMS

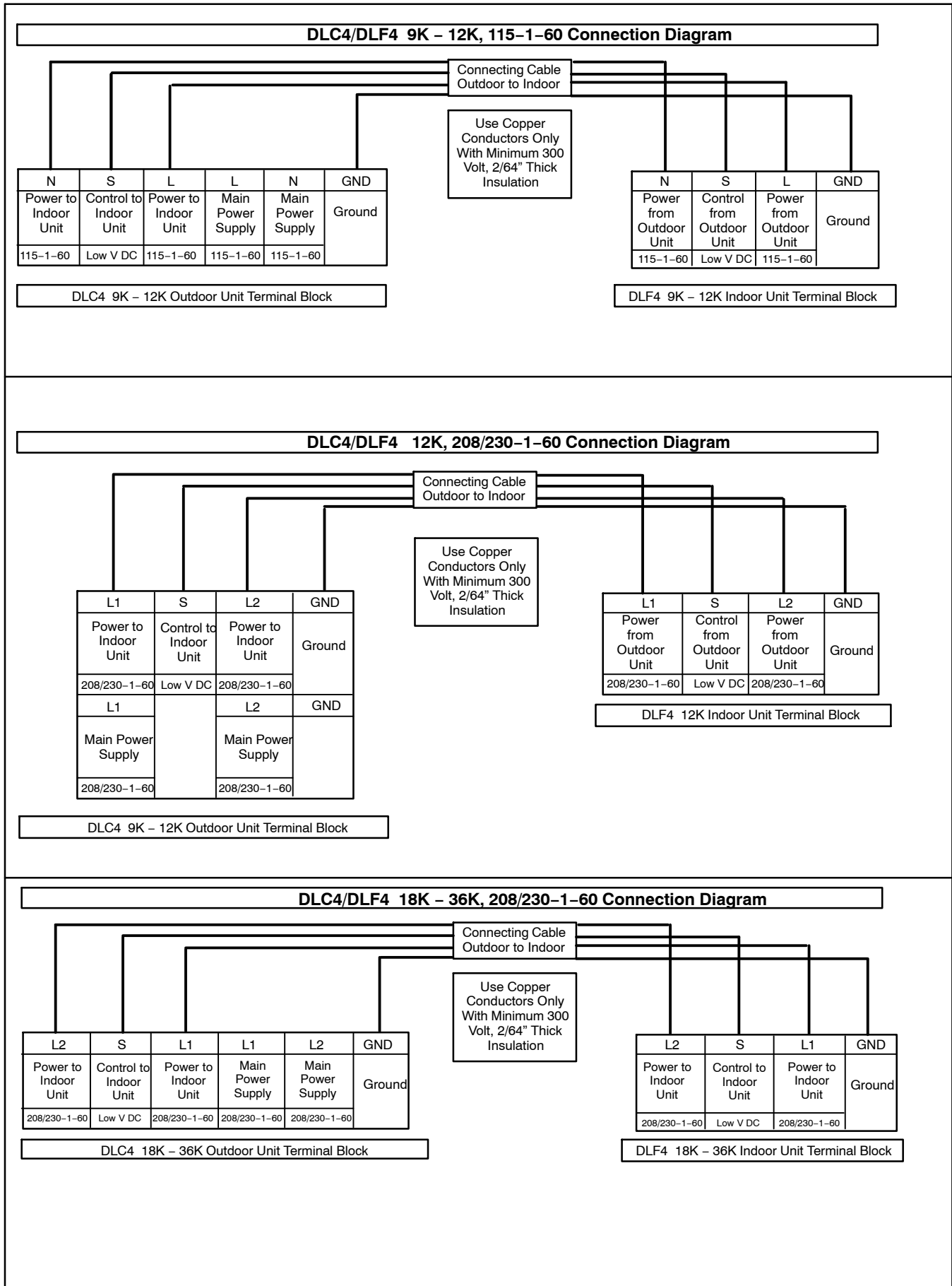

Figure 18 – Unit Wiring

TROUBLESHOOTING

The unit has onboard diagnostics. Error codes will appear on the LED display on the front panel of the indoor unit in place of the temperature display. Error codes are also displayed on the outdoor unit microprocessor board with colored LED lights. The tables following explain the error codes for the specific models.

UNITS 9K & 12K, 115 Volts					
Malfunction	Display on Indoor Unit	State of the Lamps of Outdoor Unit PCB			Reasons
	Error Code	Green-LED2	Red-LED3	Yellow_LED4	
Stop for anti-freeze protection of indoor -unit	E2		Flash-4 Times	Flash-3 Times	Refrigerant leakage. indoor unit air flow blocked. Filter dirty.
Stop for discharge temp protection	E4			Flash-7 Times	Low refrigerant. Capillary blocked. Ambient temp is abnormal.
Stop for low voltage protection	E5			Flash-5 Times	Low voltage, ambient temp is abnormal.
Stop for communication malfunction	E6	No Flash			Communication line failure, Main PCB failure. Outside interference, wiring error.
Stop for compressor overload protection	H3			Flash-8 Times	Compressor overheat. Low refrigerant. Capillary blocked.
Overload protection	H4			Flash-6 Times	Ambient temp is abnormal. Heat exchanger blocked.
Stop for IPM module protection	H5			Flash-4 Times	IPM module over temperature, low voltage, silica grease problem
DC motor (indoor unit) does not operate	H6				DC motor control terminal contact problem, fan does not rotate smoothly due to incorrect installation, motor or control panel is damaged.
Indoor ambient temperature sensor malfunction	F1				Bad terminal connection. Temp sensor malfunction.
Indoor tube temperature sensor malfunction	F2				Bad terminal connection. Temp sensor malfunction.
Outdoor ambient temperature sensor malfunction	F3		Flash-6 Times		Bad terminal connection. Temp sensor malfunction.
Outdoor tube temperature sensor malfunction	F4		Flash-5 Times		Bad terminal connection. Temp sensor malfunction.
Outdoor discharge temperature sensor malfunction	F5		Flash-7 Times		Bad terminal connection. Temp sensor malfunction.
Automatic defrosting	H1			Flash-2 Times	H1 signal normal operation, heat pump only.
Remark	1. Error codes only can be seen in the type which has the temperature display PCB. Some types do not have this function and have only the LED's on the outdoor PCB. 2. If there is normal communication between the Indoor and Outdoor unit the green LED will be on.				

UNIT 12K, 230 Volts

Malfunction	Indoor Unit Displaying Method				State of lamps of outdoor unit PCB			Reasons
	Double 8 Code Display	Indicator Display (LED Flash 0.5s-ON/0.5s-OFF)			Green LED2	Red LED3	Yellow LED4	
	Error Code	Running LED	Cooling LED	Heating LED				
Stop for anti-freeze protection of indoor -unit	E2	3s off flash 2 times				Flash-4 Times	Flash 3 Times	Refrigerant leakage. indoor unit air flow blocked. Filter dirty.
Stop for discharge temp protection	E4	3s off flash 4 times					Flash 7 Times	Low refrigerant. Capillary blocked. Ambient temp is abnormal.
Overcurrent protection	E5	3s off flash 5 times					Flash 5 Times	Low voltage, ambient temp is abnormal.
Stop for communication error	E6	3s off flash 6 times			No Flash			Communication line failure, Main PCB failure. Outside interference, wiring error.
Stop for compressor overload protection	H3			3s off flash 3 times			Flash 8 Times	Compressor overheat. Low refrigerant. Capillary blocked.
Overload protection	H4			3s off flash 4 times			Flash 6 Times	Ambient temp is abnormal. Heat exchanger blocked.
Stop for IPM module protection	H5			3s off flash 5 times			Flash 4 Times	IPM module over temperature, low voltage, silica grease problem
Indoor unit fan motor does not operate	H6	3s off flash 11 times						Motor control terminal contact problem, fan does not rotate smoothly due to incorrect installation, motor or control panel is damaged.
Indoor ambient temperature sensor malfunction	F1		3s off flash 1 times					Bad terminal connection. Temp sensor malfunction.
Indoor tube temperature sensor malfunction	F2		3s off flash 2 times					Bad terminal connection. Temp sensor malfunction.
Outdoor ambient temperature sensor malfunction	F3		3s off flash 3 times			Flash-6 Times		Bad terminal connection. Temp sensor malfunction.
Outdoor tube temperature sensor malfunction	F4		3s off flash 4 times			Flash-5 Times		Bad terminal connection. Temp sensor malfunction.
Outdoor discharge temperature sensor malfunction	F5		3s off flash 5 times			Flash-7 Times		Bad terminal connection. Temp sensor malfunction.
Jumper connection malfunction protection	C5	3s off flash 15 times						No jumper on controller or installed improperly or damaged. Corresponding circuit on mainboard has malfunction.
Unit match protection	LP						Flash 16 Times	Indoor and outdoor units not matched
Indoor fan zero-cross detection circuit malfunction	U8							Abnormal zero-cross detection circuit on mainboard.
PFC overcurrent malfunction	HC			3s off flash 6 times			Flash 14 Times	Overcurrent on PFC
High power protection	L9						Flash 9 Times	System power is too high
High voltage protection	PH		3s off flash 11 times				Flash 13 Times	DC side voltage is too high
Low voltage protection	PL			3s off flash 21 times			Flash 12 Times	DC side voltage is too low
Automatic defrosting	H1			3s off flash 1 times			Flash 2 Times	H1 signal normal operation, heat pump only.
Remark	1. Error codes only can be seen in the type which has the temperature display PCB. Some types do not have this function and have only the LED's on the outdoor PCB. 2. If there is normal communication between the Indoor and Outdoor unit the green LED will be on.							

UNIT 18K & 24K, 230 Volts

Malfunction	Indoor Unit Display			Outdoor unit display (LED's have 3 modes) □OFF, ■ON, ☆Flash				Operation Status	Malfunction	
	Error Code Display	Indicator Display (LED Flash 0.5s-ON/0.5s-OFF)			D40 /D5	D41 /D6	D42/ D16			D43/ D30
		Running LED	Cooling LED	Heating_ LED						
System High Pressure protection	E1	3s off flash 1 times			□	☆	☆	☆	Cooling, dehumidifying, compressor, outdoor fan motor stop, indoor fan motor runs. heating: all stop.	1. System high press, excess refrigerant. 2. Dirty outdoor heat exchanger 3. Outdoor ambient temp is too high
Anti-freezing protection	E2	3s off flash 2 times			■	□	■	□	Cooling, dehumidifying, compressor, outdoor fan motor stop, indoor fan motor runs.	1. Indoor unit return blocked 2. Low indoor fan motor speed 3. Evaporator is dirty.
Compressor discharge high temp protection	E4	3s off flash 4 times			■	□	■	☆	Cooling, dehumidifying, compressor, outdoor fan motor stop, indoor fan motor runs. heating: all stop.	Refer to compressor discharge protection temp.
AC overload protection	E5	3s off flash 5 times			□	■	☆	□	Cooling, dehumidifying, compressor, outdoor fan motor stop, indoor fan motor runs. heating; all stop	1. Power supply is unstable, too much variation 2. Power supply voltage low.
Indoor/Outdoor communication malfunction	E6	3s off flash 6 times			□	□	□	☆	Cooling, compressor stop, indoor fan motor runs, Heating:all stop	Refer to service manual
Anti-High temp protection	E8	3s off flash 8 times			■	□	■	■	Cooling, compressor stop, indoor fan motor runs Heating:all stop	Refer to service manual
Indoor unit fan motor no feedback	H6	3s off flash 11 times							System will stop	1. Indoor control board AP1 malfunction 2. Indoor motor M1 malfunction
Jumper connection malfunction protection	C5	3s off flash 15 times							System will stop	Indoor control board AP1 jump connector not inserted or broken
Indoor ambient temperature sensor malfunction	F1		3s off flash 1 times						Cooling, dehumidifying; indoor fan motor runs, all else stop, heating all stops	1. Room temp sensor is not connected to the control board AP1 2. Room temp sensor is damaged
Indoor evaporator sensor open circuit/short circuit	F2		3s off flash 2 times						Cooling, dehumidifying; indoor fan motor runs, all else stop, heating all stops	1. Tube temp sensor is not connected to the control board AP1 2. Tube temp sensor is damaged
Outdoor ambient sensor open circuit/short circuit	F3		3s off flash 3 times		□	□	☆	■	Cooling, dehumidifying; compressor will stop, indoor fan motor runs. Heating all stop	Outdoor temp sensor not connected or damaged, check sensor resistance value
Outdoor condenser sensor open circuit/short circuit	F4		3s off flash 4 times		□	□	☆	□	Cooling, dehumidifying; compressor will stop, indoor fan motor runs. Heating all stop	Outdoor temp sensor not connected or damaged, check sensor resistance value.
Compressor discharge temp sensor open circuit/short circuit	F5		3s off flash 5 times		□	□	☆	☆	Cooling, dehumidifying will run for 3 mins, then compressor will stop, indoor fan motor will start, heating will run 3 mins then stop.	1. Discharge temp sensor not connected or damaged, check sensor resistance values. 2. Sensor head not located correctly.

UNIT 18K & 24K, 230 Volts (Cont.)

Malfunction	Indoor Unit Display			Outdoor unit display (LED's have 3 modes) □OFF, ■ON, ☆Flash				Operation Status	Malfunction	
	Error Code Display	Indicator Display (LED Flash 0.5s-ON/0.5s-OFF)			D40 /D5	D41 /D6	D42/ D16			D43/ D30
		Running LED	Cooling LED	Heating_ LED						
Overload limit, compressor speed reduction	F6		3s off flash 6 times		■	□	☆	☆	Operation normal, compressor speed reduced	Refer to service manual
Over current compressor speed reduction	F8		3s off flash 8 times		■	■	□	■	Operation normal, compressor speed reduced	1. System voltage is too low 2. System voltage is high
Compressor discharge temp high, compressor speed reduction	F9		3s off flash 9 times		■	■	□	□	Operation normal, compressor speed reduced	1. Load is too great, ambient temp is too high 2. Refrigerant is low 3. Electric expansion valve malfunction
DC voltage is too high	PH		3s off flash 11 times		□	■	□	☆	Cooling; compressor stops, outdoor fan runs, heating all stop	1. Check voltage at terminal L and N. If higher than 265VAC, cut off power supply and restart system. 2. If input voltage is normal, check the voltage at capacitor on AP1. Replace AP1 if the capacitor voltage range is 200-280v.
System current too high	U9		3s off flash 13 times		□	■	☆	■	Cooling, dehumidifying; compressor stops, indoor fan motor runs, heating all stop.	AP1 malfunction, replace the AP1 in outdoor unit
Compressor current too high	P5		3s off flash 15 times		□	☆	□	□	Cooling, dehumidifying; compressor stops, indoor fan motor runs, heating all stop.	Refer to service manual (IPM protection, compressor speed reduction, compressor overcurrent protection)
Defrost	H1			3s off flash 1 times					Heating mode, compressor runs, indoor/outdoor fan motor stop	Normal Operation
Compressor overload protection	H3			3s off flash 3 times	□	☆	☆	□	Cooling, dehumidifying; compressor stops, indoor fan motor runs, heating all stop.	1. Compressor terminal loose, the resistance should be lower than 1 ohm 2. Refer to service manual. (discharge/overload protection)
System overload protection	H4			3s off flash 4 times					Cooling, dehumidifying; compressor stops, indoor fan motor runs, heating all stop.	Refer to service manual
IPM protection	H5			3s off flash 5 times	■	□	■	■	Cooling, dehumidifying; compressor stops, indoor fan motor runs, heating all stop.	Refer to service manual

UNIT 18K & 24K, 230 Volts (Cont.)

Malfunction	Indoor Unit Display			Outdoor unit display (LED's have 3 modes) □OFF, ■ON, ☆Flash				Operation Status	Malfunction	
	Error Code Display	Indicator Display (LED Flash 0.5s-ON/0.5s-OFF)			D40 /D5	D41 /D6	D42/ D16			D43/ D30
		Running LED	Cooling LED	Heating_ LED						
PFC protection	HC			3s off flash 6 times	□	■	☆	☆	Cooling, dehumidifying; compressor stops, indoor fan motor runs, heating all stop.	Refer to service manual
Compressor speed reduction	H7			3s off flash 7 times	□	☆	■	☆	Cooling, dehumidifying; compressor stops, indoor fan motor runs, heating all stop.	Refer to service manual
Heating, high temp	H0			3s off flash 10 times	■	□	☆	☆	Cooling, dehumidifying; compressor stops, indoor fan motor runs, heating all stop.	Refer to service manual
Start-up failure	LC			3s off flash 11 times	□	☆	□	☆	Cooling, dehumidifying; compressor stops, indoor fan motor runs, heating all stop.	Refer to service manual
Compressor current circuit malfunction	U1			3s off flash 13 times	□	☆	■	□		Replace outdoor board AP1
EEPROM malfunction	EE			3s off flash 15 times	□	□	□	■	Cooling, dehumidifying; compressor stops, indoor fan motor runs, heating all stop.	Replace outdoor board AP1
Capacity charge malfunction	PU			3s off flash 17 times	□	■	□	■	Cooling, dehumidifying; compressor stops, indoor fan motor runs, heating all stop.	Refer to capacitor charging service manual
Module Sensor circuit malfunction	P7			3s off flash 18 times	□	□	■	☆	Cooling, dehumidifying; compressor stops, indoor fan motor runs, heating all stop.	Replace the outdoor board AP1
Module over temp protection	P8			3s off flash 19 times	■	□	☆	■	Cooling, dehumidifying; compressor stops, indoor fan motor runs, heating all stop.	Check the IPM heat sink or replace outdoor board AP1
Low DC bus voltage	U3			3s off flash 20 times	□	■	■	■	Cooling, dehumidifying; compressor stops, indoor fan motor runs, heating all stop.	Supply voltage is not stable
Low DC bus voltage protection	PL			3s off flash 21 times	□	■	■	□	Cooling, dehumidifying; compressor stops, indoor fan motor runs, heating all stop.	1. Check supply voltage, if voltage lower than 150VAC, restart the unit when the power supply is normal. 2. Check reactor L connection
IPM temp high limit/decrease compressor run speed	EU				■	■	■	☆	Operation normal, compressor speed reduced	Check the IPM heat sink or replace outdoor board AP1
Four-way valve malfunction	U7				■	□	☆	□	In heating mode, all stop	1. Supply voltage is lower than AC175vV 2. 4-way valve terminal loose/broken 3. 4-way valve damaged

UNIT 18K & 24K, 230 Volts (Cont.)

Malfunction	Indoor Unit Display			Outdoor unit display (LED's have 3 modes) □OFF, ■ON, ☆Flash				Operation Status	Malfunction	
	Error Code Display	Indicator Display (LED Flash 0.5s-ON/0.5s-OFF)			D40 /D5	D41 /D6	D42/ D16			D43/ D30
		Running LED	Cooling LED	Heating_ LED						
Outdoor unit error	U9				■	■	☆	□	Cooling: compressor will stop, indoor fan runs, heating all stop	Replace outdoor board AP1
Indoor freeze protection	FH				■	■	■	□	Operation normal, compressor speed reduced	Indoor unit return air blocked or fan speed is too low
Fan module protection	L3				■	□	□	□	Cooling: outdoor fan motor and compressor stop; indoor fan runs. Heating all stop	1. Outdoor fan terminals loose, correct problem 2. Motor damaged, replace motor 3. Fan motor module on mainboard is damaged; replace mainboard AP1
Remark	1. Error codes only can be seen in the type which has the temperature display PCB. Some types do not have this function and have only the LED's on the outdoor PCB. 2. If there is normal communication between the Indoor and Outdoor unit the green LED will be on.									

UNITS 30K & 36K, 230 Volts

Malfunction	Display on Indoor Unit	State of the Lamps of Outdoor Unit PCB			Reasons
	Error Code	Yellow	Red	Green	
Compressor running (normal)		Flash-1 times			Normal
Auto defrost (normal)	H1	Flash-2 times			Normal
Anti-freezing protection	E2	Flash-3 times			Refrigerant leakage, indoor unit air flow blocked, filter dirty
Stop for IPM module protection (over current)	H5	Flash-4 times			IPM module over current, outdoor unit air flow blocked
Stop for over current protection	E5	Flash-5 times			Outdoor unit over current, ambient temp is abnormal
Overload protection	H4	Flash-6 times			Ambient temp is abnormal, heat exchanger blocked
Stop for discharge temp	E4	Flash-7 times			Low refrigerant, capillary blocked, ambient temp is abnormal
Stop of compressor overload protection	H3	Flash-8 times			Compressor shell over heat, Low refrigerant, capillary blocked
Stop for over power protection	L9	Flash-9 times			Ambient temp is abnormal
Stop for IPM module protection (overheat)	H5	Flash-10 times			IPM module over heat, outdoor unit air flow blocked
Stop for EEPROM read-write malfunction	EE	Flash-11 times			The EEPROM on the outdoor PCB mainboard cannot read or write
Stop for low voltage protection	PL	Flash-12 times			DC voltage is low
Stop for high voltage protection	PH	Flash-13 times			DC voltage is high
Stop for PFC circuit over current protection	HC	Flash-14 times			The PFC circuit over current
No feedback of indoor fan motor	H6				Indoor fan is abnormal
Stop for ID and OD doesn't match	LP	Flash-16 times			Indoor unit and outdoor unit don't match
Compressor frequency limit by by over current protection			Flash-1 times		Outdoor unit over current, ambient temp is abnormal
Compressor frequency limit by discharge temp protection			Flash-2 times		Low refrigerant, capillary blocked, ambient temp is abnormal
Compressor frequency limit by overload protection			Flash-3 times		Ambient temp is abnormal, heat exchanger blocked
Compressor frequency limit by by anti-freezing protection			Flash-4 times		Refrigerant leakage, indoor unit air flow blocked, filter dirty
Outdoor pipe temp sensor malfunction	F4		Flash-5 times		Circuit open or circuit short for outdoor condenser pipe temp sensor
Outdoor ambient temp sensor malfunction	F3		Flash-6 times		Circuit open or circuit short for outdoor environment temp sensor
Outdoor discharge temp sensor malfunction	F5		Flash-7 times		Circuit open or circuit short for outdoor gas-discharge pipe temp sensor
Normal operation			Flash-8 times		Normal compressor operation
Compressor frequency limit by IPM protection			Flash-11 times		IPM module over heat, outdoor unit air flow blocked
Compressor frequency limit by over power protection			Flash-13 times		Ambient temp is abnormal
Indoor ambient temp sensor malfunction	F1				Circuit open or circuit short for indoor environment temp sensor
Indoor tube temp sensor malfunction	F2				Circuit open or circuit short for indoor evaporator pipe temp sensor
Stop for communication malfunction	E6			Off	Communication line failure, main PCB failure, interfere source, wiring error
Communication normal				Flash-1 times	Communication is normal
Jumper cap malfunction protection	C5				The jumper is wrong or missing
No feedback of outdoor fan motor			Flash-14 times		
High pressure protection	E1		Flash-16 times		

NOTE: The lamps Flash 0.5s ON, 0.5s OFF, between two error cycle, it will be 2s off interval.