

SDS

LINEAR SLOT DIFFUSER

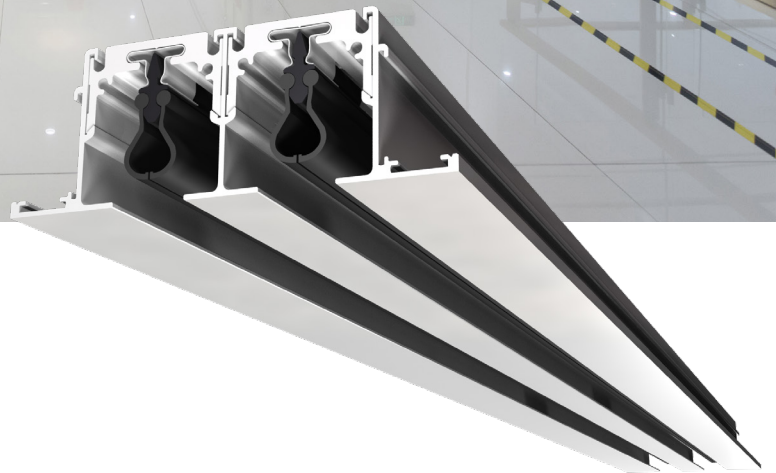

SDS

Linear Slot Diffuser

The SDS linear slot diffuser is designed to satisfy architectural applications that require continuous lengths without compromising air distribution performance. These linear slot diffusers feature fully adjustable, aerodynamic pattern controllers fabricated from extruded aluminum, and are available in a large selection of frame styles. The SDS provides the ideal combination of engineering excellence and architectural appeal.

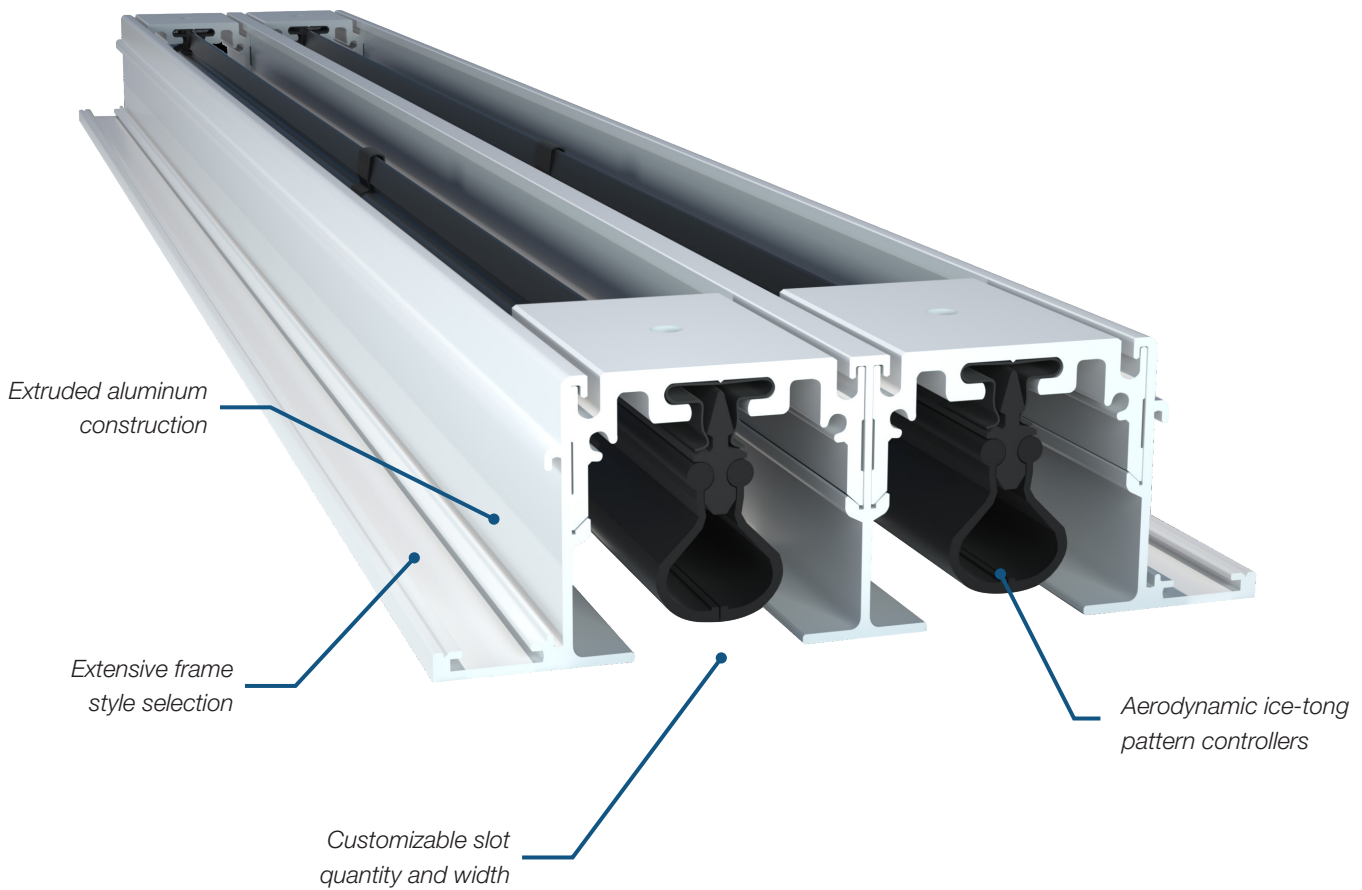

FULLY ADJUSTABLE AIR PATTERN

The precisely shaped, aerodynamic ice-tong pattern controllers provide airflow rate control as well as a full 180° range of air pattern adjustment, anywhere from fully vertical to fully horizontal. Pattern controllers come in discrete sections for multiple patterns on a single slot length.

DESIGN FLEXIBILITY

Ideal for highly architectural applications, the SDS features a one-piece extruded aluminum frame and is available with countless design options to provide ultimate flexibility. Options include:

- + Up to 10 slots for airflow pattern flexibility and additional capacity.
- + Four slot widths.
- + Available for discrete or continuous applications. Continuous installations are supplied with alignment strips for high quality architectural installations.
- + Flexible position for supply plenums allowing active and return sections along the same diffuser. This is popular for continuous slot, perimeter applications.
- + Blank-off strips are used for inactive sections and maintain a continuous look.
- + Inside, outside or flat mitered corners.
- + Flat face curve sections.
- + Multiple finish options, including anodized

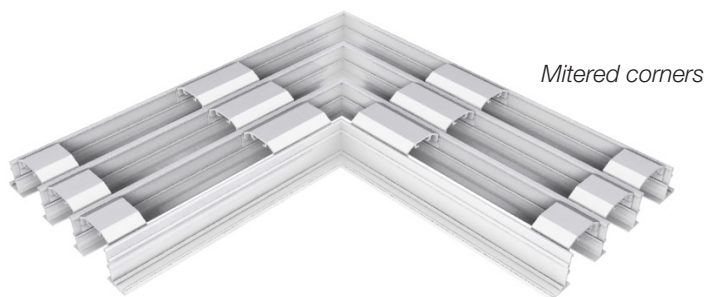

TYPICAL APPLICATIONS

Aerodynamically designed blades provide a tight horizontal pattern that maintains stability even at low airflow rates, making the SDS ideal for VAV applications.

Excellent for architectural applications, the SDS has many mounting styles and is available with multiple slot widths and quantities to meet a range of airflow requirements.

CONSTRUCTION OPTIONS

- + Models
 - Supply (SDS)
 - Return (SDR)
 - Curved supply/return (SDC)
- + Slot widths
 - 1/2 in.
 - 3/4 in.
 - 1 in.
 - 1 1/2 in.
- + Slot quantity
 - 1 to 10
- + Accessories
 - Blank-off strips
 - Mitered corner section (MC)

APPLICATION VERSATILITY

The SDS is very versatile product with various options for mounting style, curved profiles, plenums, and inlet configurations.

Mounting Styles

Concealed Plaster Frame

Ideal for architectural applications where a hidden frame is required, this frame style leaves only the open slot visible providing for a clean, flush appearance.

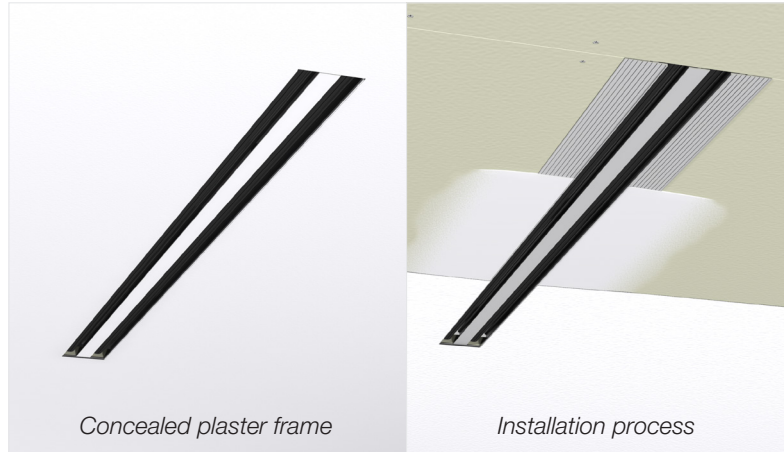

Freely Suspended

Ideal for integration with a wide variety of ceiling systems including wood slat and metal ceilings, the diffuser is suspended from the building structure with integrated brackets.

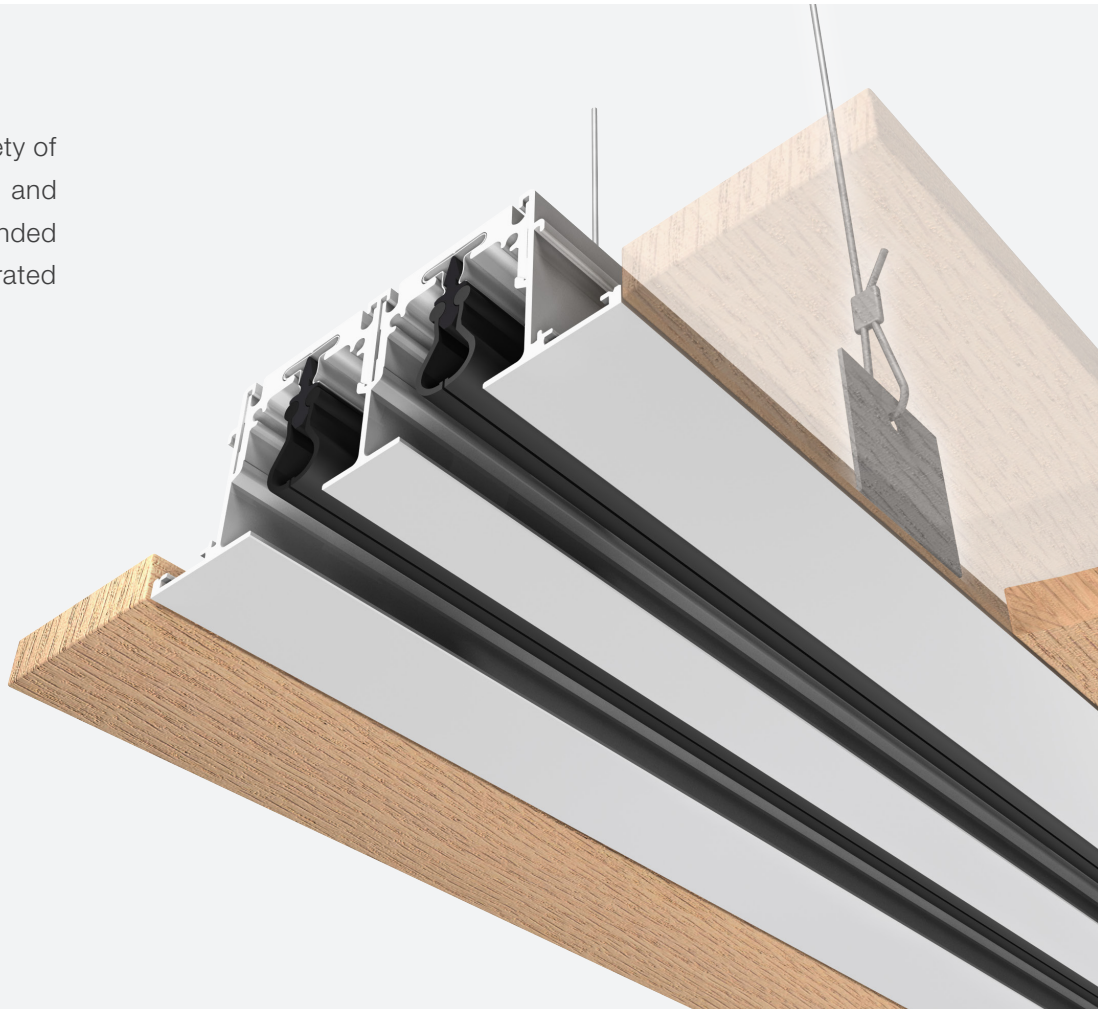

Spiral Duct Mount

Specifically designed for mounting on spiral duct without the need for a takeoff, this option blends seamlessly with existing ductwork. An equalizing grid mounted on the back of the diffuser equalizes and straightens the airflow to ensure consistent performance along the length of the diffuser.

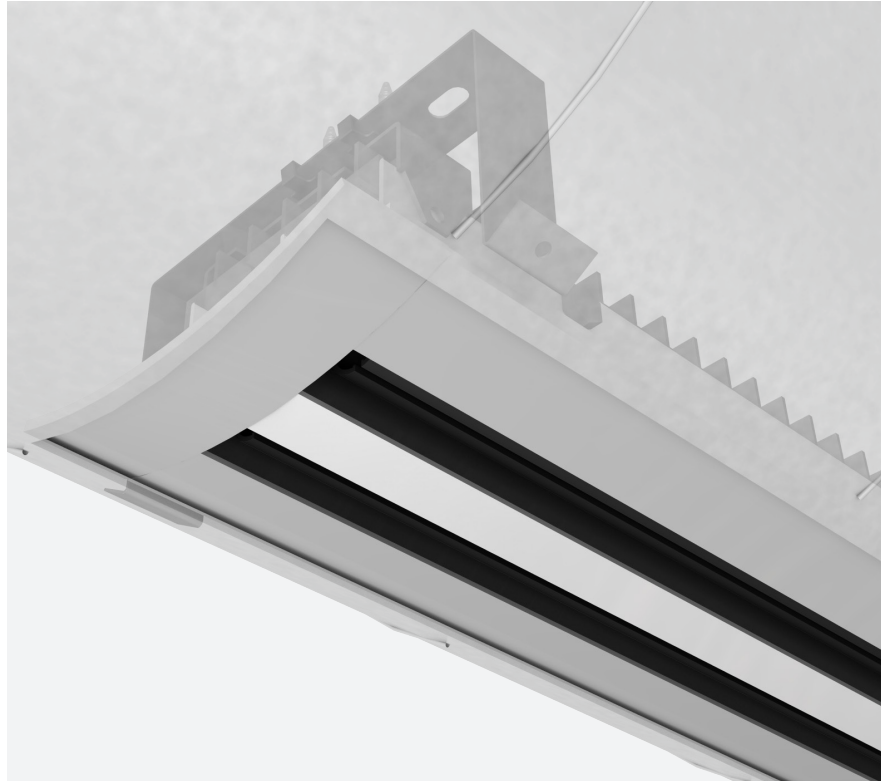

Techzone

Designed to suit Armstrong Techzone ceiling systems. Frames are provided in both 4 in. and 6 in. module widths, and are compatible with the following ceiling styles:

- + 9/16 in. tegular
- + 15/16 in. flat tee
- + 15/16 in. tegular

*15/16 in.
tegular*

*15/16 in.
flat tee*

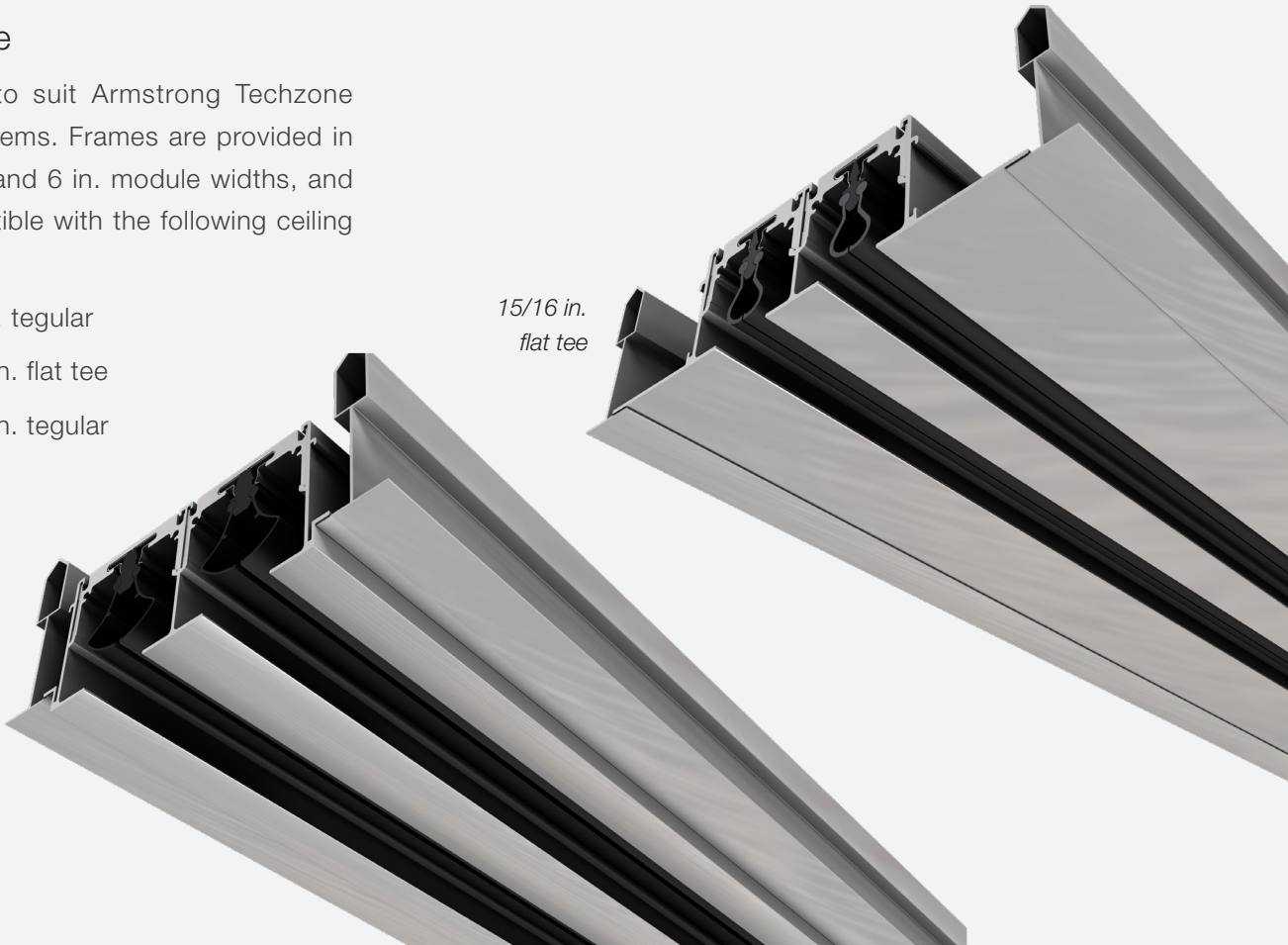

MOUNTING STYLES



Type 1 & 1B
FLANGE FRAME SCREW (1) NO
SCREW (1B) MOUNTING

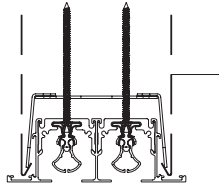

Type 2
FLANGE FRAME CONCEALED MOUNTING

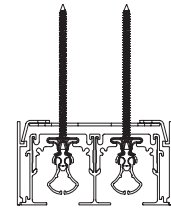

Type 3
FLUSH FIXTURE MOUNT
CONCEALED MOUNTING

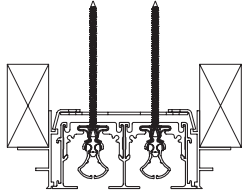

Type 6
FLUSH PLASTER FRAME
CONCEALED MOUNTING

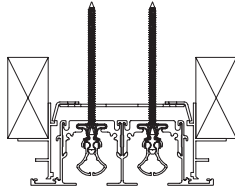

Type 7
FLANGE PLASTER FRAME
CONCEALED MOUNTING

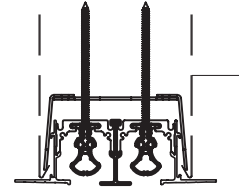

Type 8
CONCEALED PLASTER FRAME
CONCEALED MOUNTING

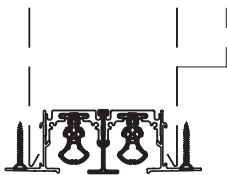

Type 8A
CONCEALED PLASTER FRAME
SCREW MOUNTING

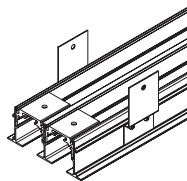

Type 9
FREELY SUSPENDED

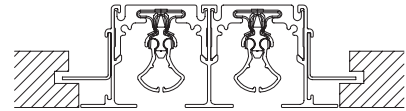

Type 12
CONCEALED SPLINE

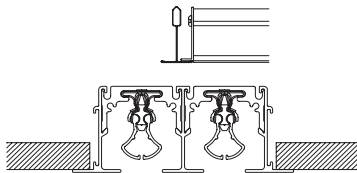

Type 14
FLUSH MOUNT LAY-IN

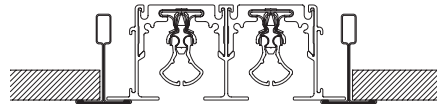

Type 15
T-BAR LAY-IN

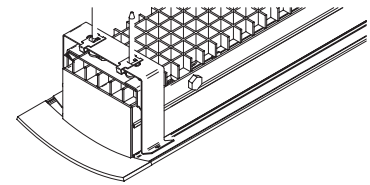

Type 16
SPIRAL DUCT MOUNT

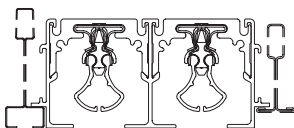

Type 17
9/16 TEGULAR LAY-IN

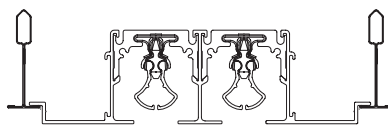

Type 18
TECHZONE LAY-IN (9/16 TEGULAR)

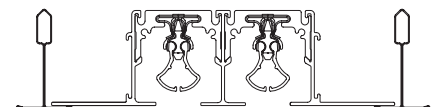

Type 19
TECHZONE LAY-IN (15/16 FLAT TEE)

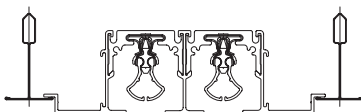

Type 20
TECHZONE LAY-IN (15/16 TEGULAR)

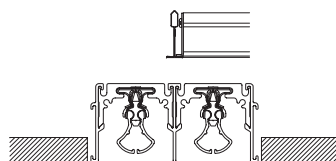

Type 916
FLUSH MOUNT LAY-IN (9/16 FLAT TEE)

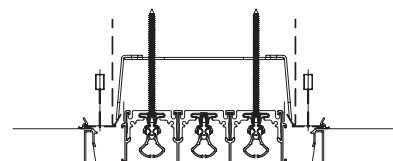

Type 21 & 22
TECHSTYLE LAY-IN

CURVED LINEAR SLOT DIFFUSER (SDC)

Curved Linear Slot Diffusers are available for flat faced, curved supply and return applications making them ideal for highly architectural projects.

Airflow Pattern Selection

Curved linear slot diffusers are available with factory set airflow in any of the following directions:

- + 1-Way towards inside curve
- + 1-Way towards outside curve
- + 2-Way (available on 2-slot only)
- + Return (no pattern control)



LINEAR SLOT PLENUM (SDA & SDB)

For simplified field assembly and reduced on-site fabrication, two plenum styles, sloped shoulder and square shoulder, are available for integration with the SDS linear slot diffuser. To ensure on-site performance matches published performance data, factory built plenums are essential.

SDA Plenum

Ideal for applications with low ceiling heights, sloped shoulder plenums help to spread the airflow and reduce throw. Increased spread results in wider coverage, reducing the number of diffusers required to cover an exterior exposure.

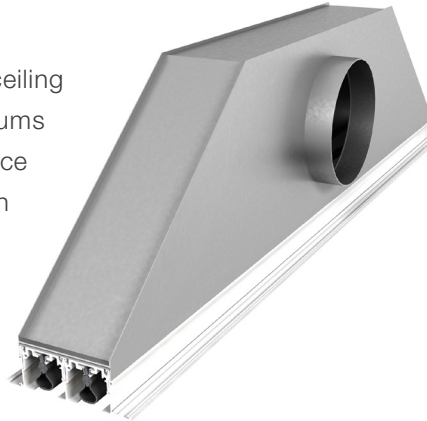

SDB Plenum

Square plenums result in longer and more condensed throws which are well suited to areas with high ceiling heights and larger distances between diffusers.

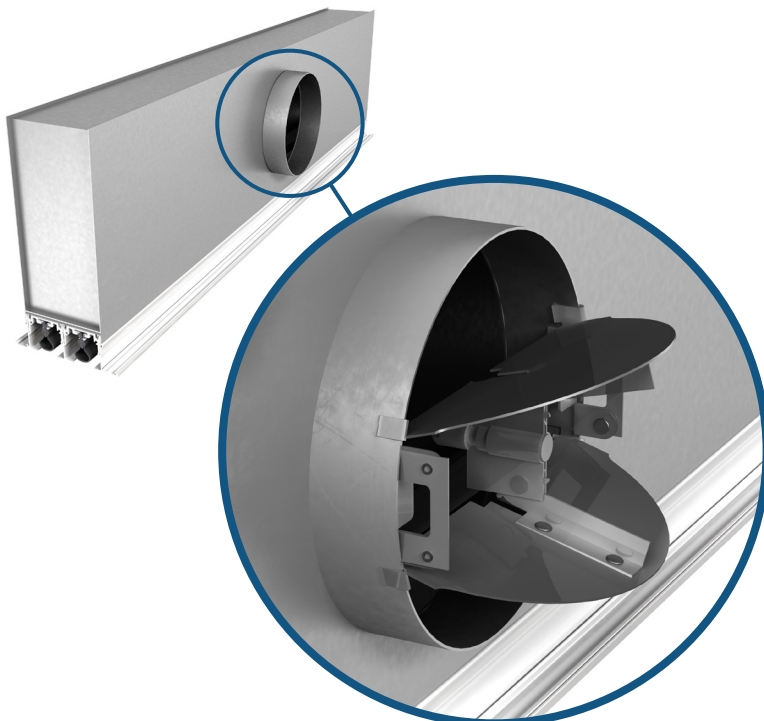

Optional butterfly damper

CONSTRUCTION

- + Style
 - Sloped shoulder (SDA)
 - Square (SDB)
- + Length
 - 24 in.*
 - 36 in.
 - 48 in.
 - 60 in.
 - 72 in.*
- + Slot quantity
 - SDA: 1-4 slots
 - SDB: 1-10 slots
- + Mounting type
 - Surface mount
 - T-bar
 - Techzone
- + Insulation
 - Fiberglass
 - Fiber free foam

*Square plenum (SDB) only

4-WAY LINEAR SLOT DIFFUSER (SDS4)

Price SDS4 Series 4 way linear slot diffusers provide exceptional performance, superior design and crisp appearance for integration with ceiling tile. This unique design combines extruded aluminum construction with a ceiling tile that is field cut and placed into the face of the diffuser.

For design flexibility, the SDS4 is available in three ceiling module sizes, with one to 4 slots in three sizes to accommodate low, medium, and high airflow. Ideal for use in high performance VAV systems, the SDS4 provides full 180° air pattern adjustment and a stable horizontal air pattern. Each slot is individually adjustable for air pattern and air volume using a precisely curved, aerodynamically shaped pattern controller.

A matching return unit is available and is supplied with a sight baffle instead of a plenum and pattern controllers.

CONSTRUCTION

- + Application
 - Supply (SDS4)
 - Return (SDR4)
- + Ceiling module size
 - 20 in. x 20 in.
 - 24 in. x 24 in.
 - 30 in. x 30 in.
- + Slot width
 - ½ in.
 - ¾ in.
 - 1 in.
- + Slot quantity
 - 1, 2, 3*, 4*

*available on 24 in. and 30 in. only
- + Options
 - Insulated plenum (SDSI4)
 - No plenum



PERFORMANCE DATA

SDS with 1/2 in. Slot Width (SDS50) and Pressurized Ceiling Plenum (Non-Ducted)

Slots	Total Pressure (in. w.g.)	H V	0.005 0.003	0.019 0.012	0.043 0.029	0.075 0.050	0.117 0.080	0.170 0.144	0.225 0.155	0.290 0.200
1	Airflow (cfm/ft)		5	10	15	20	25	30	35	40
	Throw (ft.)	H V	1-1-2 2	1-2-9 6	2-5-11 9	4-9-13 11	7-10-14 12	9-10-15 14	9-11-16 15	10-12-18 16
	Sound (NC)		-	-	-	17	23	29	33	38
2	Airflow (cfm/ft)		10	20	30	40	50	60	70	80
	Throw (ft.)	H V	1-1-4 4	2-4-12 8	5-9-15 13	8-12-17 16	10-14-19 17	12-15-21 19	13-16-23 20	14-17-24 22
	Sound (NC)		-	-	-	22	28	34	38	43
3	Airflow (cfm/ft)		15	30	45	60	75	90	105	120
	Throw (ft.)	H V	1-2-7 5	3-7-15 10	7-11-18 15	10-15-21 19	13-16-23 21	15-18-25 23	16-19-27 25	27-21-29 27
	Sound (NC)		-	-	16	25	31	37	41	46
4	Airflow (cfm/ft)		20	40	60	80	100	120	140	160
	Throw (ft.)	H V	1-2-9 7	4-9-17 12	9-13-21 18	12-17-24 22	15-19-27 25	17-21-29 27	19-23-32 29	20-24-34 31
	Sound (NC)		-	-	18	27	33	39	43	48
5	Airflow (cfm/ft)		25	50	75	100	125	150	175	200
	Throw (ft.)	H V	1-3-10 7	6-10-19 14	10-15-23 20	13-19-27 25	17-22-30 28	20-24-33 30	21-26-35 32	23-27-38 35
	Sound (NC)		-	-	19	28	34	40	44	49
6	Airflow (cfm/ft)		30	60	90	120	150	180	210	240
	Throw (ft.)	H V	2-4-11 7	7-11-21 16	11-16-26 22	15-21-29 27	18-24-33 30	21-26-36 33	23-28-39 35	24-30-42 38
	Sound (NC)		-	-	20	29	35	41	45	50
7	Airflow (cfm/ft)		35	70	105	140	175	210	245	280
	Throw (ft.)	H V	3-6-16 8	8-11-23 16	12-18-28 24	16-23-32 29	20-26-36 32	23-28-39 35	25-30-42 38	26-32-45 41
	Sound (NC)		-	-	21	30	36	42	46	51
8	Airflow (cfm/ft)		40	80	120	160	200	240	280	320
	Throw (ft.)	H V	3-6-13 8	8-12-24 17	13-19-29 26	17-25-34 31	22-27-38 35	24-30-42 38	26-32-45 41	28-35-48 43
	Sound (NC)		-	-	22	31	37	43	47	52

* Non-ducted performance tables can be used to approximate performance data when contractor fabricated plenums are supplied. Plenums must be sized to achieve equal velocity along the slot length. Inlets should be sized to reduce additional contribution of sound or pressure drop.

NC Correction for Various Diffuser Lengths

Length, ft	1	2	4	8	9	10	15	20	25	30
Supply	-16	-11	-6	-3	-2	0	+3	+5	+6	+8
Return	-10	-7	-4	-2	-1	0	+2	+3	+4	+5

Example:

A model SDS 75 diffuser 4 slots wide and 15 feet long is selected for 1800 cfm of supply air. 1800 " 15 = 120 cfm per foot. From the performance chart, the NC value is 34. The NC correction for 15 feet of length for supply service is +3. The corrected NC value is 34 + 3 = 37.

Performance Notes:

1. Tested in accordance with ASHRAE Standard 70-2023 "Method of Testing for Rating the Performance of Air Outlets and Inlets."
2. All pressures are in in. w.g.
3. Throw values are based on a 3 ft long active section. When only 1 ft is active the values are 0.6 times those shown. For a 10 ft or continuous length the values are 1.8 times those shown.
4. Horizontal (H) throw is minimum to a terminal velocity of 150 fpm, middle to 100 fpm and maximum to 50 fpm.
5. Throw data is based on supply air and room air being at isothermal conditions.
6. Horizontal throw values are based on full-open, one direction.
7. Vertical (V) throw is to a terminal velocity of 50 fpm.
8. The NC values are based on a room absorption of 10 dB, re 10⁻¹² watts and 10 ft active section. The NC values are 11 lower with vertical projection.
9. Blanks "-" indicate an NC level below 15.

PERFORMANCE DATA

SDS with 3/4 in. Slot Width (SDS75) and Pressurized Ceiling Plenum (Non-Ducted)

Slots	Total Pressure (in. w.g.)	H V	0.004 0.003	0.015 0.011	0.032 0.024	0.058 0.044	0.091 0.067	0.125 0.095	0.175 0.125	0.230 0.170
1	Airflow (cfm/ft)		6	12	18	24	30	36	42	48
	Throw (ft.)	H	1-1-3	1-3-9	3-6-11	5-9-13	8-10-15	9-11-16	10-12-17	11-13-19
	Sound (NC)	V	2	6	10	12	14	15	16	17
2	Airflow (cfm/ft)		12	24	36	48	60	72	84	96
	Throw (ft.)	H	1-1-5	2-5-13	5-10-16	9-13-19	11-15-21	13-16-23	14-17-25	15-19-27
	Sound (NC)	V	4	9	14	17	19	21	23	24
3	Airflow (cfm/ft)		18	36	54	72	90	108	126	144
	Throw (ft.)	H	1-2-8	4-8-16	7-12-20	11-16-23	14-18-26	16-20-28	18-22-30	19-23-32
	Sound (NC)	V	6	11	17	21	23	26	28	30
4	Airflow (cfm/ft)		24	48	72	96	120	144	168	192
	Throw (ft.)	H	1-3-10	5-10-19	10-15-23	13-19-27	16-21-30	19-23-32	21-25-35	22-27-37
	Sound (NC)	V	6	13	19	24	27	30	32	34
5	Airflow (cfm/ft)		30	60	90	120	150	180	210	240
	Throw (ft.)	H	2-3-11	6-11-21	11-16-26	15-21-30	18-24-33	21-26-36	23-28-39	25-30-42
	Sound (NC)	V	7	14	21	27	30	33	36	38
6	Airflow (cfm/ft)		36	72	108	144	180	216	252	288
	Throw (ft.)	H	2-4-12	8-12-23	12-18-28	16-23-32	20-26-36	23-28-40	25-31-43	26-33-45
	Sound (NC)	V	8	15	24	30	33	36	39	42
7	Airflow (cfm/ft)		42	84	126	168	210	252	294	336
	Throw (ft.)	H	3-6-12	9-13-25	13-20-30	18-25-35	22-28-39	25-31-43	27-33-46	29-35-49
	Sound (NC)	V	8	16	24	32	36	39	42	45
8	Airflow (cfm/ft)		48	96	144	192	240	288	336	384
	Throw (ft.)	H	4-7-14	9-14-27	14-21-32	19-27-37	24-30-42	26-33-47	29-35-49	30-37-52
	Sound (NC)	V	8	16	24	33	38	42	45	48

* Non-ducted performance tables can be used to approximate performance data when contractor fabricated plenums are supplied. Plenums must be sized to achieve equal velocity along the slot length. Inlets should be sized to reduce additional contribution of sound or pressure drop.

NC Correction for Various Diffuser Lengths

Length, ft	1	2	4	8	9	10	15	20	25	30
Supply	-16	-11	-6	-3	-2	0	+3	+5	+6	+8
Return	-10	-7	-4	-2	-1	0	+2	+3	+4	+5

Example:

A model SDS 75 diffuser 4 slots wide and 15 feet long is selected for 1800 cfm of supply air. 1800" 15 = 120 cfm per foot. From the performance chart, the NC value is 34. The NC correction for 15 feet of length for supply service is +3. The corrected NC value is 34 + 3 = 37.

Performance Notes:

1. Tested in accordance with ASHRAE Standard 70-2023 "Method of Testing for Rating the Performance of Air Outlets and Inlets."
2. All pressures are in in. w.g.
3. Throw values are based on a 3 ft long active section. When only 1 ft is active the values are 0.6 times those shown. For a 10 ft or continuous length the values are 1.8 times those shown.
4. Horizontal (H) throw is minimum to a terminal velocity of 150 fpm, middle to 100 fpm and maximum to 50 fpm.
5. Throw data is based on supply air and room air being at isothermal conditions.
6. Horizontal throw values are based on full-open, one direction.
7. Vertical (V) throw is to a terminal velocity of 50 fpm.
8. The NC values are based on a room absorption of 10 dB, re 10⁻¹² watts and 10 ft active section. Th NC values are 11 lower with vertical projection.
9. Blanks "-" indicate an NC level below 15.

PERFORMANCE DATA

SDS with 1 in. Slot Width (SDS100) and Pressurized Ceiling Plenum (Non-Ducted)

Slots	Total Pressure (in. w.g.)	H V	0.004 0.002	0.016 0.009	0.037 0.022	0.064 0.038	0.098 0.058	0.140 0.084	0.195 0.115	0.250 0.150
1	Airflow (cfm/ft)		8	16	24	32	40	48	56	64
	Throw (ft.)	H	1-1-3	2-3-11	3-8-13	6-11-15	9-12-17	11-13-19	12-14-20	12-15-22
	Sound (NC)	V	2	8	12	14	15	17	18	19
2	Airflow (cfm/ft)		16	32	48	64	80	96	112	128
	Throw (ft.)	H	1-2-6	3-6-15	6-12-19	11-15-22	14-17-24	15-19-27	16-25-28	18-22-31
	Sound (NC)	V	5	11	16	19	22	24	26	28
3	Airflow (cfm/ft)		24	48	72	96	120	144	168	192
	Throw (ft.)	H	1-3-10	4-10-19	10-16-23	13-19-27	16-21-30	19-23-32	20-25-35	22-27-37
	Sound (NC)	V	7	13	20	24	27	29	32	34
4	Airflow (cfm/ft)		32	64	86	128	160	192	224	256
	Throw (ft.)	H	2-3-11	6-11-22	12-17-27	15-22-31	20-24-34	22-27-37	24-29-40	25-31-43
	Sound (NC)	V	8	15	23	28	31	34	36	39
5	Airflow (cfm/ft)		40	80	120	160	200	240	280	320
	Throw (ft.)	H	2-4-13	8-13-24	13-20-30	18-24-34	22-27-38	24-30-42	26-32-45	28-34-48
	Sound (NC)	V	9	17	25	31	34	38	41	43
6	Airflow (cfm/ft)		48	96	144	192	240	288	336	384
	Throw (ft.)	H	3-5-14	9-14-27	15-21-32	19-27-37	24-30-42	27-32-45	29-35-49	30-37-52
	Sound (NC)	V	9	19	28	34	38	41	45	48
7	Airflow (cfm/ft)		56	112	168	224	280	336	392	448
	Throw (ft.)	H	3-7-15	10-15-28	15-23-35	21-29-40	26-32-45	29-35-49	31-38-53	33-40-56
	Sound (NC)	V	10	20	30	36	41	45	48	52
8	Airflow (cfm/ft)		64	128	192	256	320	384	448	512
	Throw (ft.)	H	4-8-16	11-16-31	16-25-37	22-31-43	28-34-48	30-37-52	33-40-56	35-43-60
	Sound (NC)	V	11	22	32	39	43	48	52	55

* Non-ducted performance tables can be used to approximate performance data when contractor fabricated plenums are supplied. Plenums must be sized to achieve equal velocity along the slot length. Inlets should be sized to reduce additional contribution of sound or pressure drop.

NC Correction for Various Diffuser Lengths

Length, ft	1	2	4	8	9	10	15	20	25	30
Supply	-16	-11	-6	-3	-2	0	+3	+5	+6	+8
Return	-10	-7	-4	-2	-1	0	+2	+3	+4	+5

Example:

A model SDS 75 diffuser 4 slots wide and 15 feet long is selected for 1800 cfm of supply air. $1800 \div 15 = 120$ cfm per foot. From the performance chart, the NC value is 34. The NC correction for 15 feet of length for supply service is +3. The corrected NC value is $34 + 3 = 37$.

Performance Notes:

1. Tested in accordance with ASHRAE Standard 70-2023 "Method of Testing for Rating the Performance of Air Outlets and Inlets."
2. All pressures are in in. w.g.
3. Throw values are based on a 3 ft long active section. When only 1 ft is active the values are 0.6 times those shown. For a 10 ft or continuous length the values are 1.8 times those shown.
4. Horizontal (H) throw is minimum to a terminal velocity of 150 fpm, middle to 100 fpm and maximum to 50 fpm.
5. Throw data is based on supply air and room air being at isothermal conditions.
6. Horizontal throw values are based on full-open, one direction.
7. Vertical (V) throw is to a terminal velocity of 50 fpm.
8. The NC values are based on a room absorption of 10 dB, re 10^{-12} watts and 10 ft active section. The NC values are 11 lower with vertical projection.
9. Blanks "-" indicate an NC level below 15.

PERFORMANCE DATA

SDS with 1 ½ in. Slot Width (SDS150) and Pressurized Ceiling Plenum (Non-Ducted)

Slots	Total Pressure (in. w.g.)	H V	0.016 0.007	0.037 0.017	0.058 0.028	0.085 0.043	0.119 0.062	0.161 0.086	0.216 0.119	0.271 0.154
1	Airflow (cfm/ft)		13	21	28	34	41	49	58	66
	Throw (ft.)	H	1-3-8	3-7-12	6-9-13	7-10-15	9-11-16	10-12-18	11-13-19	12-14-20
	Sound (NC)	V	7	9	10	12	13	14	15	16
2	Airflow (cfm/ft)		25	40	51	63	77	91	107	122
	Throw (ft.)	H	2-4-9	4-7-14	6-9-17	8-11-19	9-14-21	11-16-23	13-18-25	15-19-27
	Sound (NC)	V	7	12	14	16	18	19	21	22
3	Airflow (cfm/ft)		35	57	73	91	110	130	154	174
	Throw (ft.)	H	2-4-10	4-8-15	7-10-20	8-12-22	10-15-24	12-18-26	14-20-29	16-22-30
	Sound (NC)	V	6	12	15	19	21	23	25	27
4	Airflow (cfm/ft)		46	73	95	117	142	168	198	225
	Throw (ft.)	H	2-4-10	4-8-17	7-11-21	9-13-24	11-16-26	13-19-29	15-22-31	17-23-33
	Sound (NC)	V	4	11	15	18	22	26	29	31
5	Airflow (cfm/ft)		56	90	115	143	173	205	242	275
	Throw (ft.)	H	2-4-11	4-9-18	7-12-23	10-14-25	12-17-28	14-20-30	16-23-33	18-25-35
	Sound (NC)	V	3	8	14	18	22	26	30	34
6	Airflow (cfm/ft)		66	105	136	168	203	241	284	323
	Throw (ft.)	H	2-3-12	4-9-19	7-12-24	10-15-26	12-18-29	15-22-31	17-24-34	20-26-36
	Sound (NC)	V	2	7	11	17	21	25	30	34
7	Airflow (cfm/ft)		75	121	155	193	233	276	326	370
	Throw (ft.)	H	1-3-13	4-9-20	6-13-24	10-16-27	13-20-29	16-23-32	18-25-35	21-26-37
	Sound (NC)	V	2	5	9	14	21	25	29	33
8	Airflow (cfm/ft)		85	136	175	217	262	311	367	417
	Throw (ft.)	H	1-3-13	4-8-21	6-14-24	10-17-27	14-21-30	16-23-32	19-25-35	22-26-37
	Sound (NC)	V	1	4	8	12	18	24	29	33

Performance Notes:

- Tested in accordance with ASHRAE Standard 70-2023 "Method of Testing for Rating the Performance of Air Outlets and Inlets".
- All pressures are in in. w.g.
- Throw values are based on a 3 ft long active section. When only 1 ft is active the values are 0.94 times those shown. For a 10 ft or continuous length the values are 1.33 times those shown.
- Horizontal (H) throw is minimum to a terminal velocity of 150 fpm, middle to 100 fpm and maximum to 50 fpm.
- Throw data is based on supply air and room air being at isothermal conditions.
- Horizontal throw values are based on full-open, one direction.
- Vertical (V) throw is to a terminal velocity of 50 fpm.
- The NC values are based on a room absorption of 10 dB, re 10⁻¹² watts and 10 ft active section. The NC values are 11 lower with vertical projection.
- Blanks "-" indicate an NC level below 15.

NC Correction for Various Diffuser Lengths

Length, ft	1	2	4	8	9	10	15	20	25	30
Supply	-18	-13	-8	-4	-2	0	+3	+5	+6	+8
Return	-12	-9	-7	-3	-1	0	+2	+3	+4	+5

* Non-ducted performance tables can be used to approximate performance data when contractor fabricated plenums are supplied. Plenums must be sized to achieve equal velocity along the slot length. Inlets should be sized to reduce additional contribution of sound or pressure drop.

Example:

A model SDS150 diffusers 4 slots wide and 15 feet long is selected for 1425 cfm of supply air. $1425 \div 15 = 95$ cfm per foot. From the performance chart, the NC value is 22. The NC correction for 15 feet of length for supply service is +3. The corrected NC value is $22 + 3 = 25$.

PERFORMANCE DATA

SDS Return with 1/2 in. Slot Width (SDR50)

Slots	Negative Static Pressure (in. w.g.)	0.011	0.025	0.045	0.072	0.103	0.180	0.275	0.415
1	Flow Rate (cfm/ft)	10	15	20	25	30	40	50	60
	Sound (NC)	-	-	-	20	25	33	39	44
2	Flow Rate (cfm/ft)	20	30	40	50	60	80	100	120
	Sound (NC)	-	-	17	23	28	36	42	47
3	Flow Rate (cfm/ft)	30	45	60	75	90	120	150	180
	Sound (NC)	-	-	19	25	30	38	44	49
4	Flow Rate (cfm/ft)	40	60	80	100	120	160	200	240
	Sound (NC)	-	-	20	26	31	39	45	50
5	Flow Rate (cfm/ft)	50	75	100	125	150	200	250	300
	Sound (NC)	-	-	21	27	32	40	46	51
6	Flow Rate (cfm/ft)	60	90	120	150	180	240	300	360
	Sound (NC)	-	-	22	28	33	41	47	52
7	Flow Rate (cfm/ft)	70	105	140	175	210	280	350	420
	Sound (NC)	-	-	23	29	34	42	48	53
8	Flow Rate (cfm/ft)	80	120	160	200	240	320	400	480
	Sound (NC)	-	-	23	29	34	42	48	53

SDS Return with 3/4 in. Slot Width (SDR75)

Slots	Negative Static Pressure (in. w.g.)	0.007	0.028	0.063	0.108	0.170	0.250	0.345	0.450
1	Flow Rate (cfm/ft)	10	20	30	40	50	60	70	80
	Sound (NC)	-	-	18	26	32	37	41	45
2	Flow Rate (cfm/ft)	20	40	60	80	100	120	140	160
	Sound (NC)	-	-	21	29	35	40	44	48
3	Flow Rate (cfm/ft)	30	60	90	120	150	180	210	240
	Sound (NC)	-	-	23	31	37	42	46	50
4	Flow Rate (cfm/ft)	40	80	120	160	200	240	280	320
	Sound (NC)	-	-	24	32	38	43	47	51
5	Flow Rate (cfm/ft)	50	100	150	200	250	300	350	400
	Sound (NC)	-	-	25	33	39	44	48	52
6	Flow Rate (cfm/ft)	60	120	180	240	300	360	420	480
	Sound (NC)	-	-	26	34	40	45	49	53
7	Flow Rate (cfm/ft)	70	140	210	280	350	420	490	560
	Sound (NC)	-	16	27	35	41	46	50	54
8	Flow Rate (cfm/ft)	80	160	240	320	400	480	560	640
	Sound (NC)	-	16	27	35	41	46	50	54

SDS Return with 1 in. Slot Width (SDR100)

Slots	Negative Static Pressure (in. w.g.)	0.018	0.040	0.070	0.108	0.160	0.215	0.280	0.450
1	Flow Rate (cfm/ft)	20	30	40	50	60	70	80	100
	Sound (NC)	-	-	19	25	30	34	38	44
2	Flow Rate (cfm/ft)	40	60	80	100	120	140	160	200
	Sound (NC)	-	-	22	28	33	37	41	47
3	Flow Rate (cfm/ft)	60	90	120	150	180	210	240	300
	Sound (NC)	-	16	24	30	35	39	43	49
4	Flow Rate (cfm/ft)	80	120	160	200	240	280	320	400
	Sound (NC)	-	17	25	31	36	40	44	50
5	Flow Rate (cfm/ft)	100	150	200	250	300	350	400	500
	Sound (NC)	-	18	26	32	37	41	45	51
6	Flow Rate (cfm/ft)	120	180	240	300	360	420	480	600
	Sound (NC)	-	19	27	33	38	42	46	52
7	Flow Rate (cfm/ft)	140	210	280	350	420	490	560	700
	Sound (NC)	-	20	28	34	39	43	47	53
8	Flow Rate (cfm/ft)	160	240	320	400	480	560	640	800
	Sound (NC)	-	20	28	34	39	43	47	53

Performance Notes:

1. Tested in accordance with ASHRAE Standard 70-2023 "Method of Testing for Rating the Performance of Air Outlets and Inlets."
2. All pressures are in w.g.
3. Noise Criteria (NC) values are based on a room absorption of 10 dB, re 10⁻¹² watts and 10 ft active section.
4. Blanks "-" indicate an NC level below 15.

PERFORMANCE DATA

SDS with SDB Plenum – ½ in. Slot Width (SDS50)

1 Slot

Flow Rate (cfm)			60	80	100	120	140	160	180	200	220
36 in. (4 in. Inlet)	Throw (ft.)	H	4-9-13	8-10-14	9-10-15	10-12-18	11-13-19	-	-	-	-
		V	11	13	14	16	17	-	-	-	-
	Total Pressure (in. w.g.)		0.144	0.254	0.394	0.571	0.773	-	-	-	-
48 in. (5 in. Inlet)	Throw (ft.)	H	2-8-13	5-10-16	8-12-17	11-13-19	12-13-20	12-14-22	13-16-23	-	-
		V	11	13	14	17	18	19	20	-	-
	Total Pressure (in. w.g.)		0.088	0.161	0.248	0.358	0.482	0.628	0.796	-	-
60 in. (5 in. Inlet)	Throw (ft.)	H	3-9-13	3-9-14	5-10-17	9-13-18	12-13-21	12-14-22	13-14-22	13-16-23	14-17-25
		V	10	13	14	16	17	18	20	21	22
	Total Pressure (in. w.g.)		0.043	0.079	0.122	0.176	0.238	0.310	0.392	0.486	0.587
	Sound (NC)		-	-	-	25	29	33	37	40	43

2 Slot

Flow Rate (cfm)			100	130	160	190	220	250	280	310	340
36 in. (5 in. Inlet)	Throw (ft.)	H	6-10-15	9-13-18	11-14-20	12-15-22	13-16-23	14-17-25	-	-	-
		V	14	16	18	20	21	22	-	-	-
	Total Pressure (in. w.g.)		0.097	0.163	0.245	0.348	0.465	0.601	-	-	-
48 in. (6 in. Inlet)	Throw (ft.)	H	10-12-16	11-13-18	12-14-20	12-16-23	13-17-24	14-18-25	16-19-26	17-20-29	17-22-30
		V	13	17	19	20	22	23	24	25	26
	Total Pressure (in. w.g.)		0.050	0.084	0.131	0.184	0.247	0.315	0.396	0.487	0.587
60 in. (7 in. Inlet)	Throw (ft.)	H	9-12-16	10-13-18	12-14-20	12-16-21	13-17-23	14-18-25	14-20-26	16-20-27	17-21-29
		V	10	14	18	20	21	22	23	25	26
	Total Pressure (in. w.g.)		0.032	0.053	0.077	0.112	0.147	0.193	0.242	0.294	0.354
	Sound (NC)		-	-	-	24	28	32	36	39	41

3 Slot

Flow Rate (cfm)			130	160	190	220	250	280	310	340	370
36 in. (6 in. Inlet)	Throw (ft.)	H	7-11-18	9-14-20	11-15-21	13-16-23	14-17-24	15-19-26	16-19-27	16-20-29	17-21-30
		V	15	18	19	21	22	24	25	26	27
	Total Pressure (in. w.g.)		0.072	0.112	0.158	0.211	0.270	0.339	0.417	0.502	0.593
48 in. (7 in. Inlet)	Throw (ft.)	H	11-13-18	12-14-20	13-16-22	14-17-24	14-18-25	16-19-26	17-20-28	18-22-30	18-23-31
		V	13	16	19	22	23	24	25	26	28
	Total Pressure (in. w.g.)		0.045	0.066	0.096	0.126	0.164	0.206	0.251	0.302	0.359
60 in. (8 in. Inlet)	Throw (ft.)	H	10-13-18	12-14-20	12-16-21	13-17-22	14-18-25	16-20-26	16-20-27	17-21-29	18-21-30
		V	12	14	16	20	22	23	25	26	27
	Total Pressure (in. w.g.)		0.024	0.035	0.049	0.068	0.086	0.108	0.132	0.159	0.189
	Sound (NC)		-	-	-	20	23	26	29	32	34

4 Slot

Flow Rate (cfm)			160	200	240	280	320	360	400	440	480
36 in. (7 in. Inlet)	Throw (ft.)	H	7-12-19	11-15-22	12-17-24	14-19-26	16-20-28	17-21-29	18-22-31	19-23-33	20-24-34
		V	18	20	22	24	25	27	28	30	31
	Total Pressure (in. w.g.)		0.061	0.096	0.138	0.190	0.248	0.311	0.385	0.465	0.553
48 in. (8 in. Inlet)	Throw (ft.)	H	5-10-20	7-14-23	11-18-24	14-19-26	17-20-29	18-22-30	19-23-32	20-24-34	20-25-36
		V	14	18	22	24	26	28	30	31	32
	Total Pressure (in. w.g.)		0.034	0.052	0.075	0.104	0.135	0.172	0.213	0.257	0.307
60 in. (10 in. Inlet)	Throw (ft.)	H	4-7-16	5-10-22	8-16-25	10-18-26	13-20-27	16-21-29	18-22-31	20-23-33	21-25-34
		V	12	16	18	21	25	27	29	30	31
	Total Pressure (in. w.g.)		0.018	0.029	0.043	0.061	0.079	0.097	0.122	0.148	0.173
	Sound (NC)		-	-	-	21	25	28	32	35	37

Performance Notes:

- Tested in accordance with ASHRAE Standard 70-2023 "Method of Testing for Rating the Performance of Air Outlets and Inlets."
- Horizontal (H) and vertical (V) throw values are measured in feet for terminal velocities of 150 fpm (minimum), 100 fpm (middle) and 50 fpm (maximum). Spread is the maximum width of the jet defined by the above terminal velocities.
- Throw values are based on full-open, one direction.
- Throw data is based on supply air and room air being at isothermal conditions.
- The NC values are based on a room absorption of 10 dB, re 10⁻¹² watts and one diffuser. The NC values are 10 lower with vertical projection.
- All pressures are in in. w.g.
- Spread and throw data applies to Models SDB and SDBI only.
- Blanks "-" indicate an NC level below 20.
- Associated SDS diffuser must be specified and ordered as a separate item.

PERFORMANCE DATA

SDS with SDB Plenum – ¾ in. Slot Width (SDS75)

1 Slot

Flow Rate (cfm)			80	100	120	140	160	180	200	220	240
36 in. (4 in. Inlet)	Throw (ft.)	H	8-10-15	9-10-15	10-12-17	11-13-19	11-14-20	-	-	-	-
		V	12	14	16	17	18	-	-	-	-
	Total Pressure (in. w.g.)		0.164	0.254	0.369	0.499	0.654	-	-	-	-
48 in. (5 in. Inlet)	Throw (ft.)	H	8-10-14	10-11-17	10-12-18	11-13-19	12-14-20	12-16-22	13-16-23	13-17-24	-
		V	13	14	17	18	18	19	20	22	-
	Total Pressure (in. w.g.)		0.090	0.139	0.201	0.271	0.353	0.447	0.554	0.668	-
60 in. (6 in. Inlet)	Throw (ft.)	H	8-9-14	9-10-16	10-12-18	10-13-20	12-13-20	12-14-21	13-16-23	13-17-23	14-17-25
		V	13	14	16	17	18	20	20	21	22
	Total Pressure (in. w.g.)		0.058	0.093	0.133	0.186	0.244	0.307	0.377	0.458	0.539
	Sound (NC)		-	-	24	29	32	36	40	43	45

2 Slot

Flow Rate (cfm)			130	160	190	220	250	280	310	340	370
36 in. (6 in. Inlet)	Throw (ft.)	H	7-12-18	10-14-20	12-15-22	13-16-24	14-17-25	15-19-27	15-20-28	-	-
		V	16	18	19	21	23	24	25	-	-
	Total Pressure (in. w.g.)		-	0.104	0.162	0.228	0.305	0.390	0.490	-	-
48 in. (7 in. Inlet)	Throw (ft.)	H	5-11-18	7-14-20	11-16-23	13-17-24	14-18-25	16-19-28	16-20-29	17-22-30	18-23-31
		V	13	15	20	22	23	24	25	28	29
	Total Pressure (in. w.g.)		0.059	0.086	0.126	0.165	0.216	0.271	0.330	0.397	0.472
60 in. (8 in. Inlet)	Throw (ft.)	H	4-5-17	7-12-20	8-14-21	10-17-23	13-18-25	14-18-26	16-20-27	16-21-30	17-23-31
		V	13	16	18	21	22	23	25	26	27
	Total Pressure (in. w.g.)		0.045	0.066	0.091	0.146	0.161	0.202	0.247	0.297	0.353
	Sound (NC)		-	-	24	28	32	36	39	42	44

3 Slot

Flow Rate (cfm)			160	190	220	250	280	310	340	370	400
36 in. (7 in. Inlet)	Throw (ft.)	H	7-12-20	9-14-22	11-16-23	13-17-25	14-18-26	15-19-27	17-21-29	18-22-30	19-23-31
		V	17	19	21	22	23	25	27	28	29
	Total Pressure (in. w.g.)		0.073	0.107	0.140	0.183	0.230	0.280	0.336	0.400	0.466
48 in. (8 in. Inlet)	Throw (ft.)	H	5-11-20	7-17-23	10-18-24	12-18-25	14-19-28	17-20-30	18-22-30	18-23-31	19-24-34
		V	14	18	20	24	25	26	28	29	30
	Total Pressure (in. w.g.)		0.042	0.059	0.082	0.104	0.130	0.160	0.192	0.228	0.267
60 in. (10 in. Inlet)	Throw (ft.)	H	4-8-20	5-12-22	7-16-22	8-18-23	10-20-26	13-20-27	16-21-30	17-21-31	18-22-3
		V	13	16	18	20	22	26	27	29	29
	Total Pressure (in. w.g.)		0.023	0.037	0.046	0.060	0.078	0.092	0.110	0.133	0.156
	Sound (NC)		-	-	-	21	24	27	30	32	35

4 Slot

Flow Rate (cfm)			200	240	280	320	360	400	440	480	520
36 in. (8 in. Inlet)	Throw (ft.)	H	9-14-22	11-17-25	13-19-27	15-20-28	16-21-30	19-22-31	19-23-32	20-24-34	21-26-36
		V	18	21	24	25	27	29	30	31	33
	Total Pressure (in. w.g.)		0.062	0.090	0.124	0.161	0.205	0.254	0.307	0.366	0.428
48 in. (10 in. Inlet)	Throw (ft.)	H	6-12-24	10-16-25	12-18-28	13-20-29	14-22-31	17-24-32	18-24-35	19-25-36	23-26-37
		V	17	19	23	25	28	30	31	32	34
	Total Pressure (in. w.g.)		0.033	0.049	0.070	0.090	0.111	0.139	0.168	0.197	0.234
60 in. (10 in. Inlet)	Throw (ft.)	H	4-10-21	7-13-25	9-16-26	12-18-29	13-20-30	14-22-31	16-23-34	17-25-35	20-26-36
		V	14	17	20	22	25	27	30	31	33
	Total Pressure (in. w.g.)		0.021	0.031	0.044	0.057	0.070	0.088	0.107	0.125	0.148
	Sound (NC)		-	-	-	-	22	25	28	31	33

Performance Notes:

1. Tested in accordance with ASHRAE Standard 70-2023 "Method of Testing for Rating the Performance of Air Outlets and Inlets."
2. Horizontal (H) and vertical (V) throw values are measured in feet for terminal velocities of 150 fpm (minimum), 100 fpm (middle) and 50 fpm (maximum). Spread is the maximum width of the jet defined by the above terminal velocities.
3. Throw values are based on full-open, one direction.
4. Throw data is based on supply air and room air being at isothermal conditions.
5. The NC values are based on a room absorption of 10 dB, re 10⁻¹² watts and one diffuser. The NC values are 10 lower with vertical projection.
6. All pressures are in in. w.g.
7. Spread and throw data applies to Models SDB and SDB1 only.
8. Blanks "-" indicate an NC level below 20.
9. Associated SDS diffuser must be specified and ordered as a separate item.

PERFORMANCE DATA

SDS with SDB Plenum – 1 in. Slot Width (SDS100)

1 Slot

Flow Rate (cfm)			100	120	140	160	180	200	220	240	260
36 in. (5 in. Inlet)	Throw (ft.)	H	6-11-15	9-12-17	11-13-19	11-14-20	12-14-20	12-15-22	-	-	-
		V	14	15	17	18	19	20	-	-	-
	Total Pressure (in. w.g.)		0.218	0.314	0.422	0.550	0.698	0.864	-	-	-
48 in. (5 in. Inlet)	Throw (ft.)	H	5-8-17	6-12-18	8-13-19	11-14-20	13-16-22	13-16-24	14-17-24	14-18-24	-
		V	14	17	18	19	20	22	22	23	-
	Total Pressure (in. w.g.)		0.108	0.155	0.209	0.273	0.346	0.428	0.517	0.615	-
60 in. (6 in. Inlet)	Throw (ft.)	H	3-7-16	5-9-18	7-12-20	8-14-20	10-14-21	12-16-22	13-16-23	14-17-25	14-18-26
		V	14	16	17	18	20	21	22	22	23
	Total Pressure (in. w.g.)		0.062	0.090	0.125	0.164	0.207	0.254	0.308	0.363	0.429
	Sound (NC)		-	-	20	24	27	30	33	36	38

2 Slot

Flow Rate (cfm)			160	190	220	250	280	310	340	370	400
36 in. (6 in. Inlet)	Throw (ft.)	H	7-14-20	11-15-22	13-16-23	14-17-24	15-19-26	16-19-27	17-20-28	-	-
		V	17	19	21	23	24	25	26	-	-
	Total Pressure (in. w.g.)		0.122	0.171	0.229	0.293	0.368	0.452	0.545	-	-
48 in. (7 in. Inlet)	Throw (ft.)	H	5-13-20	7-16-23	10-17-24	12-18-26	16-19-28	17-20-29	18-22-30	18-23-31	19-24-32
		V	17	19	22	23	24	26	28	29	30
	Total Pressure (in. w.g.)		0.060	0.087	0.114	0.150	0.188	0.228	0.275	0.326	0.381
60 in. (8 in. Inlet)	Throw (ft.)	H	4-9-20	5-14-22	7-17-23	9-18-25	10-20-26	13-20-29	17-21-30	18-22-31	18-22-32
		V	14	17	20	22	23	25	26	27	29
	Total Pressure (in. w.g.)		0.040	0.055	0.076	0.098	0.122	0.149	0.180	0.214	0.25
	Sound (NC)		-	-	-	21	24	27	30	32	35

3 Slot

Flow Rate (cfm)			190	220	250	280	310	340	370	400	430
36 in. (8 in. Inlet)	Throw (ft.)	H	8-14-21	10-16-23	11-17-25	13-19-27	15-20-28	16-21-30	16-22-31	18-23-32	19-24-33
		V	18	20	22	24	26	27	28	29	30
	Total Pressure (in. w.g.)		0.076	0.105	0.134	0.168	0.206	0.248	0.294	0.344	0.399
48 in. (10 in. Inlet)	Throw (ft.)	H	5-12-23	7-16-24	10-18-25	12-19-28	14-20-30	16-22-31	16-23-32	17-23-34	17-24-35
		V	16	18	20	23	25	26	28	29	30
	Total Pressure (in. w.g.)		0.037	0.051	0.066	0.082	0.101	0.121	0.144	0.168	0.194
60 in. (10 in. Inlet)	Throw (ft.)	H	4-8-22	5-12-23	7-14-25	8-18-26	9-20-29	12-21-31	14-21-31	16-22-33	17-23-34
		V	14	16	18	20	22	23	26	27	29
	Total Pressure (in. w.g.)		0.027	0.033	0.043	0.057	0.067	0.080	0.097	0.113	0.130
	Sound (NC)		-	-	-	-	20	23	25	28	30

4 Slot

Flow Rate (cfm)			240	280	320	360	400	440	480	520	560
36 in. (8 in. Inlet)	Throw (ft.)	H	9-15-25	12-17-27	13-18-28	14-21-30	15-23-32	17-24-33	20-24-34	21-25-36	22-26-37
		V	19	23	25	27	29	30	31	32	33
	Total Pressure (in. w.g.)		0.070	0.096	0.125	0.159	0.198	0.239	0.284	0.333	0.388
48 in. (10 in. Inlet)	Throw (ft.)	H	6-12-25	8-16-26	11-18-29	14-22-30	18-23-31	19-24-34	20-25-35	22-26-36	23-28-37
		V	17	20	23	25	29	30	31	32	35
	Total Pressure (in. w.g.)		0.036	0.051	0.066	0.081	0.102	0.123	0.144	0.171	0.198
60 in. (10 in. Inlet)	Throw (ft.)	H	5-9-23	7-13-26	8-14-29	9-17-29	12-20-31	14-21-33	16-22-35	20-26-36	21-26-36
		V	14	17	20	22	25	26	30	33	33
	Total Pressure (in. w.g.)		0.025	0.036	0.046	0.057	0.071	0.086	0.101	0.120	0.139
	Sound (NC)		-	-	-	-	20	23	26	28	31

Performance Notes:

- Tested in accordance with ASHRAE Standard 70-2023 "Method of Testing for Rating the Performance of Air Outlets and Inlets."
- Horizontal (H) and vertical (V) throw values are measured in feet for terminal velocities of 150 fpm (minimum), 100 fpm (middle) and 50 fpm (maximum). Spread is the maximum width of the jet defined by the above terminal velocities.
- Throw values are based on full-open, one direction.
- Throw data is based on supply air and room air being at isothermal conditions.
- The NC values are based on a room absorption of 10 dB, re 10⁻¹² watts and one diffuser. The NC values are 10 lower with vertical projection.
- All pressures are in in. w.g.
- Spread and throw data applies to Models SDB and SDBI only.
- Blanks "-" indicate an NC level below 20.
- Associated SDS diffuser must be specified and ordered as a separate item.

PERFORMANCE DATA

SDS with SDB Plenum – 1 ½ in. Slot Width (SDS150)

1 Slot

Flow Rate (cfm)			120	140	160	180	200	220	240	260	280
36 in. (5 in. Inlet)	Throw (ft.)	H V	13-16-23 15	14-17-25 16	15-19-26 17	16-20-28 18	17-21-30 19	18-22-31 20	19-23-32 21	19-24-34 21	20-25-35 22
	Total Pressure (in. w.g.)		0.135	0.184	0.240	0.304	0.375	0.454	0.541	0.634	0.736
	Sound (NC)		26	30	34	37	40	43	45	47	49
48 in. (6 in. Inlet)	Throw (ft.)	H V	9-14-21 15	11-16-23 16	12-17-24 17	14-18-26 18	15-19-27 19	16-20-28 20	17-21-30 21	18-22-31 22	18-23-32 23
	Total Pressure (in. w.g.)		0.071	0.096	0.125	0.159	0.196	0.237	0.282	0.331	0.384
	Sound (NC)		17	21	25	28	31	34	36	38	40
60 in. (6 in. Inlet)	Throw (ft.)	H V	5-9-19 16	7-11-20 17	8-12-22 18	9-14-23 19	10-16-24 20	11-17-26 21	12-19-27 22	14-20-28 23	15-20-29 24
	Total Pressure (in. w.g.)		0.056	0.077	0.100	0.127	0.157	0.190	0.226	0.265	0.307
	Sound (NC)		-	19	22	26	28	31	33	36	38

2 Slot

Flow Rate (cfm)			190	220	250	280	310	340	370	400	430
36 in. (6 in. Inlet)	Throw (ft.)	H V	14-19-27 19	16-20-29 20	18-22-30 21	19-23-32 23	20-24-34 24	20-25-35 25	21-26-37 26	22-27-38 27	23-28-40 28
	Total Pressure (in. w.g.)		0.120	0.161	0.208	0.261	0.320	0.385	0.455	0.532	0.615
	Sound (NC)		25	29	33	36	39	41	43	45	47
48 in. (8 in. Inlet)	Throw (ft.)	H V	10-16-22 16	12-17-24 17	14-18-26 18	15-19-27 19	16-20-29 20	17-21-30 21	18-22-31 22	19-23-32 23	19-24-34 24
	Total Pressure (in. w.g.)		0.049	0.066	0.086	0.107	0.132	0.158	0.188	0.219	0.253
	Sound (NC)		-	17	20	23	26	28	31	33	35
60 in. (10 in. Inlet)	Throw (ft.)	H V	8-12-18 13	9-14-20 14	11-15-21 15	12-16-22 16	13-16-23 17	14-17-24 18	15-18-25 18	15-19-26 19	16-19-27 20
	Total Pressure (in. w.g.)		0.026	0.034	0.045	0.056	0.068	0.082	0.098	0.114	0.132
	Sound (NC)		-	-	-	-	17	19	21	23	25

3 Slot

Flow Rate (cfm)			220	250	280	310	340	370	400	430	460
36 in. (8 in. Inlet)	Throw (ft.)	H V	12-17-29 18	13-20-30 19	15-22-32 20	16-24-34 21	18-25-36 22	19-26-37 23	21-27-39 24	23-28-40 25	24-29-41 26
	Total Pressure (in. w.g.)		0.059	0.076	0.096	0.117	0.141	0.167	0.196	0.226	0.259
	Sound (NC)		15	19	22	25	27	29	32	33	35
48 in. (10 in. Inlet)	Throw (ft.)	H V	7-14-23 12	10-16-24 13	12-17-26 14	13-19-27 15	14-20-28 16	15-21-29 16	17-22-31 17	18-22-32 18	19-23-33 18
	Total Pressure (in. w.g.)		0.028	0.037	0.046	0.056	0.068	0.080	0.094	0.108	0.124
	Sound (NC)		-	-	15	18	21	23	25	27	29
60 in. (10 in. Inlet)	Throw (ft.)	H V	5-11-17 7	6-13-18 8	8-14-19 9	9-14-20 10	11-15-21 10	13-16-22 11	13-16-23 12	14-17-24 13	14-17-24 14
	Total Pressure (in. w.g.)		0.023	0.030	0.037	0.045	0.055	0.065	0.076	0.087	0.100
	Sound (NC)		-	-	-	-	17	19	21	23	25

4 Slot

Flow Rate (cfm)			280	320	360	400	440	480	520	560	600
36 in. (8 in. Inlet)	Throw (ft.)	H V	13-20-30 19	15-23-32 20	17-24-34 22	19-26-36 23	21-27-38 24	23-28-40 25	24-29-41 26	25-30-43 27	26-31-44 28
	Total Pressure (in. w.g.)		0.075	0.098	0.124	0.153	0.185	0.220	0.258	0.299	0.344
	Sound (NC)		19	23	26	29	31	34	36	38	40
48 in. (10 in. Inlet)	Throw (ft.)	H V	7-13-25 13	9-14-26 15	11-16-28 16	12-18-29 16	13-20-31 17	14-22-32 18	6-23-34 19	17-25-35 19	18-26-36 20
	Total Pressure (in. w.g.)		0.035	0.046	0.058	0.071	0.086	0.103	0.120	0.140	0.160
	Sound (NC)		-	-	15	18	21	23	25	27	29
60 in. (10 in. Inlet)	Throw (ft.)	H V	3-7-14 9	4-8-16 10	5-9-18 11	6-10-20 12	8-11-23 13	8-12-25 14	9-13-26 15	10-14-27 15	10-15-28 16
	Total Pressure (in. w.g.)		0.029	0.038	0.048	0.060	0.072	0.086	0.101	0.117	0.134
	Sound (NC)		-	-	-	16	19	21	23	25	27

Performance Notes:

- Tested in accordance with ASHRAE Standard 70-2023 "Method of Testing for Rating the Performance of Air Outlets and Inlets."
- Horizontal (H) and vertical (V) throw values are measured in feet for terminal velocities of 150 fpm (minimum), 100 fpm (middle) and 50 fpm (maximum). Spread is the maximum width of the jet defined by the above terminal velocities.
- Throw values are based on full-open, one direction.
- Throw data is based on supply air and room air being at isothermal conditions.
- The NC values are based on a room absorption of 10 dB, re 10⁻¹² watts and one diffuser. The NC values are 10 lower with vertical projection.
- All pressures are in in. w.g.
- Spread and throw data applies to Models SDB and SDBI only.
- Blanks "-" indicate an NC level below 15.
- Associated SDS diffuser must be specified and ordered as a separate item.

PERFORMANCE DATA

SDS with SDA Plenum – ½ in. Slot Width (SDS50)

1 Slot

Flow Rate (cfm)			60	80	100	120	140	160	180	200	220
Nom. Length	Throw (ft.)	H	3-5-9	4-7-11	5-8-12	6-9-13	8-10-14	9-11-15	9-11-16	10-12-17	10-12-18
		V	2-4-7	3-5-8	4-6-9	5-7-10	5-8-11	6-8-11	7-9-12	7-9-13	8-10-14
	Spread (ft.)	H	4-7-13	6-10-16	7-12-18	9-13-19	12-15-21	13-16-22	13-16-24	15-18-25	15-18-27
		V	3-5-9	4-6-10	5-8-12	6-9-13	6-10-14	8-10-14	9-12-16	9-12-17	10-13-18
36 in. (4 in. Inlet)	Total Pressure (in. w.g.)		0.144	0.254	0.394	0.571	0.773	-	-	-	-
	Sound (NC)		23	32	39	45	49	-	-	-	-
48 in. (5 in. Inlet)	Total Pressure (in. w.g.)		0.088	0.161	0.254	0.358	0.482	0.628	0.796	-	-
	Sound (NC)		-	28	35	40	45	49	52	-	-
60 in. (5 in. Inlet)	Total Pressure (in. w.g.)		0.043	0.079	0.122	0.176	0.238	0.310	0.392	0.486	0.587
	Sound (NC)		-	-	-	25	29	33	37	40	43

2 Slot

Flow Rate (cfm)			100	130	160	190	220	250	280	310	340
Nom. Length	Throw (ft.)	H	4-6-11	5-7-12	6-9-14	7-10-15	8-11-16	9-12-17	10-13-18	11-13-19	11-14-20
		V	2-3-5	2-4-6	3-4-7	3-5-7	4-6-8	4-6-8	5-6-9	5-7-9	6-7-10
	Spread (ft.)	H	6-9-16	7-10-18	9-13-21	10-15-22	12-16-24	13-18-25	15-19-27	16-19-28	16-21-30
		V	3-4-6	3-5-8	4-5-9	4-6-9	5-8-10	5-8-10	6-8-12	6-9-12	8-9-13
36 in. (5 in. Inlet)	Total Pressure (in. w.g.)		0.097	0.163	0.245	0.348	0.465	0.601	-	-	-
	Sound (NC)		21	28	35	40	44	48	-	-	-
48 in. (6 in. Inlet)	Total Pressure (in. w.g.)		0.050	0.084	0.131	0.184	0.247	0.315	0.396	0.487	0.587
	Sound (NC)		-	-	25	30	35	39	43	46	49
60 in. (7 in. Inlet)	Total Pressure (in. w.g.)		0.032	0.053	0.077	0.112	0.147	0.193	0.242	0.294	0.354
	Sound (NC)		-	-	-	24	28	32	36	39	41

3 Slot

Flow Rate (cfm)			130	160	190	220	250	280	310	340	370
Nom. Length	Throw (ft.)	H	4-6-11	5-7-12	6-9-14	7-10-15	8-11-16	9-12-17	10-13-18	10-13-18	10-13-19
		V	2-2-5	2-3-5	2-3-6	3-4-7	3-4-7	3-5-8	4-5-8	4-6-8	4-6-9
	Spread (ft.)	H	6-9-16	7-10-18	9-13-21	10-15-22	12-16-24	13-18-25	15-19-27	16-19-28	16-21-30
		V	3-3-6	3-4-6	3-4-8	4-5-9	4-5-9	4-6-10	5-6-10	5-8-10	5-8-12
36 in. (6 in. Inlet)	Total Pressure (in. w.g.)		0.072	0.112	0.158	0.211	0.270	0.339	0.417	0.502	0.593
	Sound (NC)		20	26	31	36	40	43	46	49	51
48 in. (7 in. Inlet)	Total Pressure (in. w.g.)		0.045	0.066	0.096	0.126	0.164	0.206	0.251	0.302	0.359
	Sound (NC)		-	-	23	29	33	36	39	42	44
60 in. (8 in. Inlet)	Total Pressure (in. w.g.)		0.024	0.035	0.049	0.068	0.086	0.108	0.132	0.159	0.189
	Sound (NC)		-	-	-	20	23	26	29	32	34

4 Slot

Flow Rate (cfm)			160	200	240	280	320	360	400	440	480
Nom. Length	Throw (ft.)	H	4-6-12	5-7-13	6-9-15	7-10-16	8-12-17	9-13-18	10-13-19	11-14-20	12-15-21
		V	1-2-4	2-3-5	2-3-6	2-4-7	3-4-7	3-5-8	3-5-8	4-6-9	4-6-9
	Spread (ft.)	H	6-9-18	7-10-19	9-13-22	10-15-24	12-18-25	13-19-27	15-19-28	16-21-30	18-22-31
		V	1-3-5	3-4-6	3-4-8	3-5-9	4-5-9	4-6-10	4-6-10	5-8-12	5-8-12
36 in. (7 in. Inlet)	Total Pressure (in. w.g.)		0.061	0.096	0.138	0.190	0.248	0.311	0.385	0.465	0.553
	Sound (NC)		20	26	32	37	41	44	47	51	53
48 in. (8 in. Inlet)	Total Pressure (in. w.g.)		0.034	0.052	0.075	0.104	0.135	0.172	0.213	0.257	0.307
	Sound (NC)		-	-	23	28	31	35	38	41	44
60 in. (10 in. Inlet)	Total Pressure (in. w.g.)		0.018	0.029	0.043	0.061	79	0.097	0.122	0.148	0.173
	Sound (NC)		-	-	-	21	25	28	32	25	37

Performance Notes:

- Tested in accordance with ASHRAE Standard 70-2023 "Method of Testing for Rating the Performance of Air Outlets and Inlets."
- Horizontal (H) and vertical (V) throw values are measured in feet for terminal velocities of 150 fpm (minimum), 100 fpm (middle) and 50 fpm (maximum). Spread is the maximum width of the jet defined by the above terminal velocities.
- Throw values are based on full-open, one direction.
- Throw data is based on supply air and room air being at isothermal conditions.
- The NC values are based on a room absorption of 10 dB, re 10⁻¹² watts and one diffuser. The NC values are 10 lower with vertical projection.
- All pressures are in in. w.g.
- Spread and throw data applies to Models SDA and SDAI only.
- Blanks "-" indicate an NC level below 15.
- Associated SDS diffuser must be specified and ordered as a separate item.

PERFORMANCE DATA

SDS with SDA Plenum – ¾ in. Slot Width (SDS75)

1 Slot

Flow Rate (cfm)			20	40	60	80	100	120	140	160
Nom. Length	Throw (ft.)	H		3-5-9	4-6-10	4-7-11	5-7-11	6-9-13	7-10-14	8-10-15
	Spread (ft.)	V		2-4-5	3-4-6	3-4-6	3-5-7	4-6-8	5-6-8	5-6-9
		H		4-7-13	5-9-14	6-9-15	7-10-16	9-13-19	10-15-21	12-15-22
	V		3-5-7	3-5-8	4-5-8					
36 in. (4 in. Inlet)	Total Pressure (in. w.g.)			0.051	0.116	0.206	0.321	0.463	0.630	0.823
	Sound (NC)			19	28	35	40	44	48	51
48 in. (5 in. Inlet)	Total Pressure (in. w.g.)			0.025	0.056	0.100	0.156	0.225	0.306	0.400
	Sound (NC)			-	20	27	32	36	40	43
60 in. (6 in. Inlet)	Total Pressure (in. w.g.)			0.014	0.032	0.057	0.089	0.128	0.174	0.228
	Sound (NC)			-	-	20	25	30	33	36

2 Slot

Flow Rate (cfm)			130	160	190	220	250	280	310	340	370
Nom. Length	Throw (ft.)	H	5-7-12	6-9-13	7-10-14	8-11-15	9-11-16	10-12-17	10-13-18	11-13-19	11-14-20
	Spread (ft.)	V	2-4-6	3-4-6	4-5-7	4-5-7	5-6-8	5-6-8	5-6-9	5-6-9	6-7-10
		H	7-10-18	9-13-19	10-15-21	12-16-22	13-16-24	15-18-25	15-19-27	16-19-28	16-21-30
	V	3-5-8	4-5-8	5-6-9	5-6-9	6-8-10	6-8-10	6-8-12	6-8-12	8-9-13	
36 in. (6 in. Inlet)	Total Pressure (in. w.g.)		0.104	0.162	0.228	0.305	0.390	0.490	0.602	-	-
	Sound (NC)		24	30	35	40	44	47	50	-	-
48 in. (7 in. Inlet)	Total Pressure (in. w.g.)		0.059	0.086	0.126	0.165	0.216	0.221	0.330	0.397	0.472
	Sound (NC)		-	21	26	30	34	38	41	43	46
60 in. (8 in. Inlet)	Total Pressure (in. w.g.)		0.045	0.066	0.091	0.146	0.161	0.202	0.247	0.297	0.353
	Sound (NC)		-	-	24	28	32	36	39	42	44

3 Slot

Flow Rate (cfm)			160	190	220	250	280	310	340	370	400
Nom. Length	Throw (ft.)	H	5-7-12	6-8-13	6-10-14	7-11-15	8-11-16	9-12-17	10-12-18	10-13-19	11-13-19
	Spread (ft.)	V	2-3-5	3-4-6	3-5-6	3-5-7	4-5-7	4-5-8	5-6-8	5-6-8	5-6-9
		H	7-10-18	9-12-19	9-15-21	10-16-22	12-16-24	13-18-25	15-18-27	15-19-28	15-19-28
	V	3-4-6	4-5-8	4-6-8	4-6-9	5-6-9	5-6-10	6-8-10	6-8-10	6-8-10	6-8-12
36 in. (7 in. Inlet)	Total Pressure (in. w.g.)		0.073	0.107	0.140	0.183	0.270	0.280	0.336	0.400	0.466
	Sound (NC)		21	26	31	35	38	41	44	43	49
48 in. (8 in. Inlet)	Total Pressure (in. w.g.)		0.042	0.059	0.082	0.104	0.130	0.160	0.192	0.228	0.267
	Sound (NC)		-	-	23	26	30	33	35	37	40
60 in. (10 in. Inlet)	Total Pressure (in. w.g.)		0.023	0.037	0.046	0.060	0.078	0.092	0.110	0.133	0.156
	Sound (NC)		-	-	-	21	24	27	30	32	35

4 Slot

Flow Rate (cfm)			200	240	280	320	360	400	440	480	520
Nom. Length	Throw (ft.)	H	5-8-13	6-9-14	7-11-15	8-12-16	9-12-17	10-13-18	11-14-19	11-14-20	12-15-21
	Spread (ft.)	V	2-3-6	3-4-6	3-5-7	4-5-7	4-5-7	4-5-8	5-6-8	5-6-8	5-6-9
		H	7-12-19	9-13-21	10-16-22	12-18-24	13-18-25	15-19-27	16-21-28	16-21-30	16-21-30
	V	3-4-8	4-5-8	4-6-9	5-6-9	5-6-9	5-6-10	6-8-10	6-8-10	6-8-12	6-8-12
36 in. (8 in. Inlet)	Total Pressure (in. w.g.)		0.062	0.090	0.124	0.161	0.205	0.254	0.307	0.366	0.428
	Sound (NC)		22	27	32	36	39	42	45	48	51
48 in. (10 in. Inlet)	Total Pressure (in. w.g.)		0.033	0.049	0.070	0.090	0.111	0.139	0.168	0.197	0.234
	Sound (NC)		-	20	25	28	32	35	38	41	44
60 in. (10 in. Inlet)	Total Pressure (in. w.g.)		0.021	0.031	0.044	0.057	0.070	0.088	0.107	0.125	0.148
	Sound (NC)		-	-	-	-	22	25	28	31	33

Performance Notes:

- Tested in accordance with ASHRAE Standard 70-2023 "Method of Testing for Rating the Performance of Air Outlets and Inlets."
- Horizontal (H) and vertical (V) throw values are measured in feet for terminal velocities of 150 fpm (minimum), 100 fpm (middle) and 50 fpm (maximum). Spread is the maximum width of the jet defined by the above terminal velocities.
- Throw values are based on full-open, one direction.
- Throw data is based on supply air and room air being at isothermal conditions.
- The NC values are based on a room absorption of 10 dB, re 10⁻¹² watts and one diffuser. The NC values are 10 lower with vertical projection.
- All pressures are in in. w.g.
- Spread and throw data applies to Models SDA and SDAI only.
- Blanks "-" indicate a NC level below 15.
- Associated SDS diffuser must be specified and ordered as a separate item.

PERFORMANCE DATA

SDS with SDA Plenum – 1 in. Slot Width (SDS100)

1 Slot

Flow Rate (cfm)			100	120	140	160	180	200	220	240	260
Nom. Length	Throw (ft.)	H	4-6-11	5-8-12	6-10-13	7-10-14	8-11-15	9-11-16	10-12-17	10-12-17	10-13-18
		V	2-3-6	3-4-7	3-5-7	3-5-8	4-6-8	4-6-9	5-6-9	5-7-9	6-7-10
	Spread (ft.)	H	6-9-16	7-12-18	9-15-19	10-15-21	12-16-22	13-16-24	15-18-25	15-18-25	15-19-27
		V	3-4-8	4-5-9	4-6-9	4-6-10	5-8-10	5-8-12	6-8-12	6-9-12	8-9-13
36 in. (4 in. Inlet)	Total Pressure (in. w.g.)		0.218	0.314	0.422	0.550	0.698	0.864	-	-	-
	Sound (NC)		32	37	42	46	49	52	-	-	-
48 in. (5 in. Inlet)	Total Pressure (in. w.g.)		0.108	0.155	0.209	0.273	0.346	0.428	0.517	0.615	-
	Sound (NC)		-	22	26	30	34	37	40	43	-
60 in. (6 in. Inlet)	Total Pressure (in. w.g.)		0.062	0.090	0.125	0.164	0.207	0.254	0.308	0.363	0.429
	Sound (NC)		-	-	20	24	27	30	33	36	38

2 Slot

Flow Rate (cfm)			160	190	220	250	280	310	340	370	400
Nom. Length	Throw (ft.)	H	5-8-12	6-9-14	7-10-15	8-11-16	9-12-17	10-12-18	11-13-18	11-13-19	11-14-20
		V	2-3-6	3-4-7	3-5-7	3-5-7	4-6-8	4-6-8	5-6-8	5-6-9	5-6-9
	Spread (ft.)	H	7-12-18	9-13-21	10-15-22	12-16-24	13-18-25	15-18-27	16-19-27	16-19-28	16-21-30
		V	3-4-8	4-5-9	4-6-9	4-6-9	5-8-10	5-8-10	6-8-10	6-8-12	6-8-12
36 in. (6 in. Inlet)	Total Pressure (in. w.g.)		0.122	0.171	0.229	0.293	0.368	0.452	0.545	-	-
	Sound (NC)		24	29	34	37	41	44	46	-	-
48 in. (7 in. Inlet)	Total Pressure (in. w.g.)		0.060	0.087	0.114	0.150	0.188	0.228	0.275	0.326	0.381
	Sound (NC)		-	-	23	27	30	33	36	39	41
60 in. (8 in. Inlet)	Total Pressure (in. w.g.)		0.040	0.055	0.076	0.98	0.122	0.149	0.180	0.214	0.250
	Sound (NC)		-	-	-	21	24	27	30	32	35

3 Slot

Flow Rate (cfm)			190	220	250	280	310	340	370	400	430
Nom. Length	Throw (ft.)	H	5-7-12	6-8-14	6-10-15	7-11-15	8-11-16	8-12-17	9-12-18	10-13-18	11-13-19
		V	2-3-6	2-3-6	3-4-6	3-4-7	3-5-7	3-5-7	4-5-8	4-6-8	4-6-8
	Spread (ft.)	H	7-10-18	9-12-21	9-15-22	10-16-22	12-16-24	12-18-25	13-18-27	15-19-27	16-19-28
		V	3-4-8	3-4-8	4-5-8	4-5-9	4-6-9	4-6-9	5-6-10	5-8-10	5-8-10
36 in. (8 in. Inlet)	Total Pressure (in. w.g.)		0.076	0.105	0.134	0.168	0.206	0.248	0.294	0.344	0.399
	Sound (NC)		23	28	32	35	38	40	43	46	48
48 in. (10 in. Inlet)	Total Pressure (in. w.g.)		0.037	0.051	0.066	0.082	0.101	0.121	0.144	0.168	0.194
	Sound (NC)		-	-	22	26	29	32	34	37	39
60 in. (10 in. Inlet)	Total Pressure (in. w.g.)		0.027	0.033	0.043	0.057	0.067	0.080	0.097	0.113	0.130
	Sound (NC)		-	-	-	-	20	23	25	28	30

4 Slot

Flow Rate (cfm)			240	280	320	360	400	440	480	520	560
Nom. Length	Throw (ft.)	H	5-8-14	6-9-15	7-11-16	8-12-17	9-12-18	10-13-18	10-13-18	11-14-20	12-15-21
		V	2-3-6	2-4-6	3-4-6	3-5-7	4-5-7	4-5-8	5-6-8	5-6-8	5-6-9
	Spread (ft.)	H	7-12-21	9-13-22	10-16-24	12-18-25	13-18-27	15-19-27	15-19-28	16-21-30	18-22-31
		V	3-4-8	3-5-8	4-5-8	4-6-9	5-6-9	5-6-10	5-8-10	6-8-10	6-8-12
36 in. (8 in. Inlet)	Total Pressure (in. w.g.)		0.070	0.096	0.125	0.159	0.198	0.239	0.284	0.333	0.388
	Sound (NC)		21	26	30	33	37	40	42	45	47
48 in. (10 in. Inlet)	Total Pressure (in. w.g.)		0.036	0.051	0.066	0.081	0.102	0.123	0.144	0.171	0.198
	Sound (NC)		-	-	21	25	28	31	34	36	39
60 in. (10 in. Inlet)	Total Pressure (in. w.g.)		0.025	0.036	0.044	0.057	0.071	0.086	0.101	0.120	0.139
	Sound (NC)		-	-	-	-	20	23	26	28	31

Performance Notes:

1. Tested in accordance with ASHRAE Standard 70-2023 "Method of Testing for Rating the Performance of Air Outlets and Inlets."
2. Horizontal (H) and vertical (V) throw values are measured in feet for terminal velocities of 150 fpm (minimum), 100 fpm (middle) and 50 fpm (maximum). Spread is the maximum width of the jet defined by the above terminal velocities.
3. Throw values are based on full-open, one direction.
4. Throw data is based on supply air and room air being at isothermal conditions.
5. The NC values are based on a room absorption of 10 dB, re 10⁻¹² watts and one diffuser. The NC values are 10 lower with vertical projection.
6. All pressures are in in. w.g.
7. Spread and throw data applies to Models SDA and SDA1 only.
8. Blanks "-" indicate an NC level below 15.
9. Associated SDS diffuser must be specified and ordered as a separate item.



Product Improvement is a continuing endeavour at Price. Therefore, specifications are subject to change without notice. Consult your Price Sales Representative for current specifications or more detailed information. Not all products may be available in all geographic areas. All goods described in this document are warranted as described in the Limited Warranty shown at priceindustries.com. The complete Price product catalog can be viewed online at priceindustries.com.