



AISI S212–07 (2012)



AISI STANDARD

North American Standard for Cold-Formed Steel Framing— Header Design

2007 Edition (Reaffirmed 2012)

Revision of AISI/COFS/HD - 2004

Endorsed by



DISCLAIMER

The material contained herein has been developed by the American Iron and Steel Institute Committee on Framing Standards. The Committee has made a diligent effort to present accurate, reliable, and useful information on cold-formed steel framing design and installation. The Committee acknowledges and is grateful for the contributions of the numerous researchers, engineers, and others who have contributed to the body of knowledge on the subject. Specific references are included in the *Commentary*.

With anticipated improvements in understanding of the behavior of cold-formed steel framing and the continuing development of new technology, this material will become dated. It is anticipated that AISI will publish updates of this material as new information becomes available, but this cannot be guaranteed.

The materials set forth herein are for general purposes only. They are not a substitute for competent professional advice. Application of this information to a specific project should be reviewed by a design professional. Indeed, in many jurisdictions, such review is required by law. Anyone making use of the information set forth herein does so at their own risk and assumes any and all liability arising therefrom.

1st Printing - June 2007
2nd Printing - April 2014

Copyright American Iron and Steel Institute 2007

PREFACE

The American Iron and Steel Institute Committee on Framing Standards has developed AISI S212, the *North American Standard for Cold-Formed Steel Framing – Header Design*, to provide technical information and specifications for designing headers made from cold-formed steel. This standard is intended for adoption and use in the United States, Canada and Mexico.

This standard provides an integrated treatment of Allowable Strength Design (ASD), Load and Resistance Factor Design (LRFD), and Limit States Design (LSD). This is accomplished by including the appropriate resistance factors (ϕ) for use with LRFD and LSD, and the appropriate factors of safety (Ω) for use with ASD. It should be noted that LSD is limited to Canada and LRFD and ASD are limited to Mexico and the United States.

The Committee acknowledges and is grateful for the contributions of the numerous engineers, researchers, producers and others who have contributed to the body of knowledge on the subjects. The Committee wishes to also express their appreciation for the support of the Steel Framing Alliance and the Canadian Sheet Steel Building Institute.

AISI COMMITTEE ON FRAMING STANDARDS

Richard Haws, <i>Chairman</i>	NUCONSTEEL
Steve Fox, <i>Vice Chairman</i>	Canadian Sheet Steel Building Institute
Jay Larson, <i>Secretary</i>	American Iron and Steel Institute
Don Allen	Steel Stud Manufacturers Association
Bill Babich	ITW Building Components Group
John Butts	John F. Butts & Associates
Brad Cameron	Keymark Engineering
Nader Elhajj	NAHB Research Center
Jeff Ellis	Simpson Strong-Tie
Ray Frobosilo	Super Stud Building Products
Michael Gardner	Gypsum Association
Stephen Gatto	Compass International
Greg Greenlee	USP Structural Connectors
Jeff Klaiman	ADTEK Engineers
Roger LaBoube	University of Missouri-Rolla
John Matsen	Matsen Ford Design Associates
Kenneth Pagano	Scosta Corporation
Mike Pellock	Aegis Metal Framing
Nabil Rahman	The Steel Network
Greg Ralph	Dietrich Industries
Harry Ray	Allied Studco
Gary Rolih	Consultant
Ben Schafer	Johns Hopkins University
Reynaud Serrette	Santa Clara University
Fernando Sesma	California Expanded Metal Products
Sutton Stephens	Kansas State University
Tom Trestain	T.W.J. Trestain Structural Engineering
Steven Walker	Steven H. Walker, P.Eng.
Lei Xu	University of Waterloo
Rahim Zadeh	Marino\Ware

DESIGN METHODS SUBCOMMITTEE

Roger LaBoube, <i>Chairman</i>	University of Missouri-Rolla
Jay Larson, <i>Secretary</i>	American Iron and Steel Institute
Don Allen	Steel Stud Manufacturers Association
Bill Babich	ITW Building Components Group
John Butts	John F. Butts & Associates
Brad Cameron	Keymark Engineering
Nader Elhajj	NAHB Research Center
Jeff Ellis	Simpson Strong-Tie
Steve Fox	Canadian Sheet Steel Building Institute
Greg Greenlee	USP Structural Connectors
Jeff Klaiman	ADTEK Engineers
Richard Layding	NUCONSTEEL
John Matsen	Matsen Ford Design Associates
Mike Pellock	Aegis Metal Framing
Dean Peyton	Anderson-Peyton Engineers
Nabil Rahman	The Steel Network
Greg Ralph	Dietrich Industries
Gary Rolih	Consultant
Ben Schafer	Johns Hopkins University
Reynaud Serrette	Santa Clara University
Fernando Sesma	California Expanded Metal Products
Sutton Stephens	Kansas State University
Tom Trestain	T.W.J. Trestain Structural Engineering
Lei Xu	University of Waterloo
Rahim Zadeh	Marino\Ware

HEADER DESIGN TASK GROUP

Sutton Stephens, <i>Chairman</i>	Kansas State University
Jay Larson, <i>Secretary</i>	American Iron and Steel Institute
Nader Elhajj	NAHB Research Center
Steve Fox	Canadian Sheet Steel Building Institute
Roger LaBoube	University of Missouri-Rolla
Nabil Rahman	The Steel Network
Greg Ralph	Dietrich Industries
Reynaud Serrette	Santa Clara University

This Page Intentionally Left Blank

TABLE OF CONTENTS
NORTH AMERICAN STANDARD FOR COLD-FORMED STEEL FRAMING –
HEADER DESIGN

DISCLAIMER.....	ii
PREFACE	iii
AIISI COMMITTEE ON FRAMING STANDARDS.....	iv
DESIGN METHODS SUBCOMMITTEE.....	v
HEADER DESIGN TASK GROUP	v
A. GENERAL.....	1
A1 Scope	1
A2 Definitions	1
A3 Loads and Load Combinations	1
A4 Referenced Documents.....	1
B. DESIGN.....	2
B1 Back-to-Back Headers.....	2
B1.1 Bending.....	2
B1.2 Shear	2
B1.3 Web Crippling.....	2
B1.4 Bending and Shear.....	2
B1.5 Bending and Web Crippling.....	2
B2 Box Headers	2
B2.1 Bending.....	2
B2.2 Shear	2
B2.3 Web Crippling	2
B2.4 Bending and Shear.....	3
B2.5 Bending and Web Crippling.....	3
B3 Double L-Headers	4
B3.1 Bending.....	4
B3.2 Shear	6
B3.3 Web Crippling	6
B3.4 Bending and Shear	6
B3.5 Bending and Web Crippling.....	6
B4 Single L-Headers	6
B4.1 Bending.....	6
B4.2 Shear	7
B4.3 Web Crippling.....	7
B4.4 Bending and Shear.....	7
B4.5 Bending and Web Crippling.....	7
B5 Inverted L-Header Assemblies.....	8
C. INSTALLATION	9
C1 Back-to-Back and Box Headers.....	9
C2 Double and Single L-Headers.....	9
C3 Inverted L-Header Assemblies.....	9

This Page Intentionally Left Blank

NORTH AMERICAN STANDARD FOR COLD-FORMED STEEL FRAMING – HEADER DESIGN

A. GENERAL

A1 Scope

The design and installation of *cold-formed steel* box and back-to-back *headers*, and double and single *L-headers* for load carrying purposes in buildings shall be in accordance with AISI S100 [CSA S136] and AISI S200, except as modified by the provisions of this standard. Alternatively *headers* shall be permitted to be designed solely in accordance with the AISI S100 [CSA S136].

This standard shall not preclude the use of other materials, assemblies, structures or designs not meeting the criteria herein, when the other materials, assemblies, structures or designs demonstrate equivalent performance for the intended use to those specified in this standard. Where there is a conflict between this standard and other reference documents the requirements contained within this standard shall govern.

This standard shall include Sections A through C inclusive.

A2 Definitions

Where terms appear in this standard in italics, such terms shall have meaning as defined in AISI S200. Terms included in square brackets are specific to *LSD* terminology. Terms not italicized shall have the ordinary accepted meaning in the context for which they are intended.

A3 Loads and Load Combinations

Buildings or other structures, and all parts therein, shall be designed to safely support all loads that are expected to affect the structure during its life in accordance with the *applicable building code*. In the absence of an *applicable building code*, the loads, forces, and combinations of loads shall be in accordance with accepted engineering practice for the geographical area under consideration as specified by the applicable sections of *Minimum Design Loads for Buildings and Other Structures* (ASCE 7) in the United States and Mexico, and the *National Building Code of Canada* (NBCC) in Canada.

A4 Referenced Documents

The following documents or portions thereof are referenced within this standard and shall be considered part of the requirements of this document.

1. AISI S100-07, *North American Specification for the Design of Cold-Formed Steel Structural Members*, American Iron and Steel Institute, Washington, DC.
2. AISI S200-07, *North American Standard for Cold-Formed Steel Framing—General Provisions*, American Iron and Steel Institute, Washington, DC.
3. ASCE 7-05 Including Supplement No. 1, *Minimum Design Loads for Buildings and Other Structures*, American Society of Civil Engineers, Reston, VA.
4. CAN/CSA S136-07, *North American Specification for the Design of Cold-Formed Steel Structural Members*, Canadian Standards Association, Mississauga, Ontario, Canada.
5. NBCC 2005, *National Building Code of Canada*, 2005 Edition, National Research Council of Canada, Ottawa, Ontario, Canada.

B. DESIGN

B1 Back-to-Back Headers

The provisions of this section shall be limited to back-to-back *header* beams that are installed using *cold-formed steel C-shape* sections in accordance with Section C1.

B1.1 Bending

Bending alone shall be evaluated by using Section C3.1.1 of AISI S100 [CSA S136].

B1.2 Shear

Shear alone shall be evaluated by using Section C3.2 of AISI S100 [CSA S136].

B1.3 Web Crippling

Web crippling alone shall be evaluated by using Section C3.4 of AISI S100 [CSA S136]. For back-to-back *header* beams, the equations for built-up sections shall be used.

B1.4 Bending and Shear

The combination of bending and shear shall be evaluated by using Section C3.3 of AISI S100 [CSA S136].

B1.5 Bending and Web Crippling

Webs of back-to-back *header* beams subjected to a combination of bending and web crippling shall be designed using Section C3.5 of AISI S100 [CSA S136]. For back-to-back *header* beams, the equations for built-up sections shall be used.

B2 Box Headers

The provisions of this section shall be limited to box *header* beams that are installed using *cold-formed steel C-shape* sections in accordance with Section C1.

B2.1 Bending

Bending alone shall be evaluated by using Section C3.1.1 of AISI S100 [CSA S136].

B2.2 Shear

Shear alone shall be evaluated by using Section C3.2 of AISI S100 [CSA S136].

B2.3 Web Crippling

Web crippling alone shall be evaluated by using Section C3.4 of AISI S100 [CSA S136]. For box *header* beams the equations for shapes having single *webs* shall be used. P_n for an interior-one-flange loading condition, with the applicable Ω or ϕ factor defined below, shall be permitted to be multiplied by α , where α accounts for the increased strength due to the *track* and is defined as follows:

α = parameter defined by equation B2.3-1 or B2.3-2

Ω = 1.80 for ASD

ϕ = 0.85 for LRFD

ϕ = 0.80 for LSD

Where the *track section design thickness* ≥ 0.0346 in. (0.879 mm), the *track flange width* ≥ 1 in. (25.4 mm), the *C-shape section depth* ≤ 12 in. (305 mm) and the *C-shape section design thickness* ≥ 0.0346 in. (0.879 mm):

$$\alpha = 2.3 \frac{t_t}{t_c} \geq 1.0 \quad (\text{Eq. B2.3-1})$$

where:

$$t_t = 0.0346 \text{ in. (0.879 mm)}$$

$$t_c = \text{design thickness of the C-shape section}$$

Where the above limits are not met:

$$\alpha = 1.0 \quad (\text{Eq. B2.3-2})$$

B2.4 Bending and Shear

The combination of bending and shear shall be evaluated by using Section C3.3 of AISI S100 [CSA S136].

B2.5 Bending and Web Crippling

Webs of box *header* beams subjected to a combination of bending and web crippling shall be designed using either Section C3.5 of AISI S100 [CSA S136] or the following equations:

(a) For ASD:

$$\frac{P}{P_n} + \frac{M}{M_n} \leq \frac{1.5}{\Omega} \quad (\text{Eq. B2.5-1})$$

where

P = required web crippling strength

M = required flexural strength

P_n = nominal web crippling strength computed by Section B2.3

Ω = 1.85

M_n shall be as defined in Section C3.1 of AISI S100 [CSA S136]

(b) For LRFD and LSD:

$$\frac{P_u}{P_n} + \frac{M_u}{M_n} \leq 1.5\phi \quad (\text{Eq. B2.5-2})$$

where

P_u = required web crippling strength [factored resistance]

M_u = required flexural strength [factored resistance]

P_n = nominal web crippling strength [nominal resistance] computed by Section B2.3

ϕ = 0.85 for LRFD

ϕ = 0.80 for LSD

M_n shall be as defined in Section C3.1 of AISI S100 [CSA S136]

B3 Double L-Headers

The provisions of this section shall be limited to double L-headers that are installed using cold-formed steel angles in accordance with Section C2, having the following limitations:

- (1) Minimum top flange width = 1.5 inches (38.1 mm)
- (2) Maximum vertical leg dimension = 10 inches (254 mm)
- (3) Minimum base steel thickness = 0.033 inches (0.838 mm)
- (4) Maximum design thickness = 0.0713 inches (1.829 mm)
- (5) Minimum design yield strength, $F_y = 33$ ksi (230 MPa)
- (6) Maximum design yield strength, $F_y = 50$ ksi (345 MPa)
- (7) Cripple stud located at all load points
- (8) Minimum bearing length 1.5 inches (38.1 mm) at load points
- (9) Minimum wall width = 3.5 inches (88.9 mm)
- (10) Maximum span = 16'-0" (4.88 m)

B3.1 Bending

B3.1.1 Gravity Loading

- (a) For a double L-header beam having a vertical leg dimension of 8 inches (203 mm) or less, the design shall be based on the bending capacity of the L-sections alone. The gravity nominal flexural strength [moment resistance], M_{ng} , shall be determined as follows:

$$M_{ng} = S_{ec} F_y \quad (\text{Eq. B3.1.1-1})$$

where

F_y = yield strength used for design

S_{ec} = elastic section modulus of the effective section calculated at $f = F_y$ in the extreme compression fibers

- (b) For a double L-header beam having a vertical leg dimension greater than 8 inches (203 mm), and having a span-to-vertical leg dimension ratio greater than or equal to 10, design shall be based on the flexural capacity of the L-sections alone (Eq. B3.1.1-1).
- (c) For a double L-header beam having a vertical leg dimension greater than 8 inches (203 mm) and having a span-to-vertical leg dimension ratio less than 10, the gravity nominal flexural strength [moment resistance], M_{ng} , shall be determined as follows:

$$M_{ng} = 0.9 S_{ec} F_y \quad (\text{Eq. B3.1.1-2})$$

where

F_y = yield strength used for design

S_{ec} = elastic section modulus of the effective section calculated at $f = F_y$ in the extreme compression fibers

B3.1.2 Uplift Loading

For a double L-header beam, the *nominal uplift flexural strength* [moment resistance], M_{nu} , shall be determined as follows:

$$M_{nu} = R M_{ng} \quad (Eq. B3.1.2-1)$$

where

M_{ng} = gravity *nominal flexural strength* [moment resistance]
determined by Eq. B3.1.1-1

R = uplift factor

$$= 0.25 \text{ for } L_h/t \leq 150$$

$$= 0.20 \text{ for } L_h/t \geq 170$$

= use linear interpolation for $150 < L_h/t < 170$

L_h = vertical leg dimension of the angle

t = *design thickness*

B3.1.3 Design Moment Capacity

(a) For ASD, the *allowable flexural strength* shall be determined as follows:

For gravity,

$$M_a = M_{ng}/\Omega \quad (Eq. B3.1.3-1)$$

$$\Omega = 1.67 \text{ for beams with } L_h \leq 8 \text{ inches (203 mm)}$$

$$\Omega = 2.25 \text{ for beams with } L_h > 8 \text{ inches (203 mm)}$$

For uplift,

$$M_a = M_{nu}/\Omega \quad (Eq. B3.1.3-2)$$

$$\Omega = 2.0$$

(b) For LRFD, the *design flexural strength* shall be determined as follows:

For gravity,

$$M_u = \phi M_{ng} \quad (Eq. B3.1.3-3)$$

$$\phi = 0.90 \text{ for beams with } L_h \leq 8 \text{ inches (203 mm)}$$

$$\phi = 0.70 \text{ for beams with } L_h > 8 \text{ inches (203 mm)}$$

For uplift,

$$M_u = \phi M_{nu} \quad (Eq. B3.1.3-4)$$

$$\phi = 0.80$$

(c) For LSD, the *factored moment resistance* shall be determined as follows:

For gravity,

$$M_u = \phi M_{ng} \quad (Eq. B3.1.3-5)$$

$$\phi = 0.85 \text{ for beams with } L_h \leq 8 \text{ inches (203 mm)}$$

$$\phi = 0.65 \text{ for beams with } L_h > 8 \text{ inches (203 mm)}$$

For uplift,

$$M_u = \phi M_{nu} \quad (Eq. B3.1.3-6)$$

$$\phi = 0.75$$

B3.2 Shear

Shear alone need not be considered for the design of *L-header* beams that are fabricated and installed in accordance with this standard.

B3.3 Web Crippling

Web crippling alone need not be considered for the design of *L-header* beams that are fabricated and installed in accordance with this standard.

B3.4 Bending and Shear

The combination of bending and shear need not be considered for the design of *L-header* beams fabricated and installed in accordance with this standard.

B3.5 Bending and Web Crippling

The combination of bending and web crippling need not be considered for the design of *L-header* beams fabricated and installed in accordance with this standard.

B4 Single L-Headers

The provisions of this section shall be limited to single *L-headers* that are installed using *cold-formed steel* angles in accordance with Section C2, having the following limitations:

- (1) Minimum top *flange* width = 1.5 inches (38.1 mm)
- (2) Maximum vertical leg dimension = 8 inches (203 mm)
- (3) Minimum *base steel thickness* = 0.033 inches (0.838 mm)
- (4) Maximum *design thickness* = 0.0566 inches (1.448 mm)
- (5) Minimum design *yield strength*, $F_y = 33$ ksi (230 MPa)
- (6) Maximum design *yield strength*, $F_y = 50$ ksi (345 MPa)
- (7) Cripple *stud* located at all load points
- (8) Minimum bearing length 1.5 inches (38.1 mm) at load points
- (9) Minimum wall width = 3.5 inches (88.9 mm)
- (10) Maximum *span* = 4'-0" (1.219 m)

B4.1 Bending

B4.1.1 Gravity Loading

- (a) For a single *L-header* beam having a vertical leg dimension of 6 inches (152 mm) or less, the design shall be based on the flexural capacity of the L-section alone. The gravity *nominal flexural strength* [moment *resistance*], M_{ng} , shall be determined as follows:

$$M_{ng} = S_{ec} F_y \quad (Eq. B4.1.1-1)$$

where

F_y = *yield strength* used for design

S_{ec} = elastic section modulus of the effective section calculated at $f = F_y$ in the extreme compression fibers

- (b) For a single L-*header* beam having a vertical leg dimension greater than 6 inches (152 mm), but less than or equal to 8 inches (203 mm), the gravity *nominal flexural strength* [moment *resistance*], M_{ng} , shall be determined as follows:

$$M_{ng} = 0.9 S_{ec} F_y \quad (\text{Eq. B4.1.1-2})$$

where

F_y = yield strength used for design

S_{ec} = elastic section modulus of the effective section calculated at $f = F_y$ in the extreme compression fibers

B4.1.2 Uplift Loading

[Reserved]

B4.1.3 Design Moment Capacity

- (a) For ASD, the *allowable flexural strength* shall be determined as follows:

For gravity,

$$M_a = M_{ng}/\Omega \quad (\text{Eq. B4.1.3-1})$$

$$\Omega = 1.67$$

- (b) For LRFD, the *design flexural strength* shall be determined as follows:

For gravity,

$$M_u = \phi M_{ng} \quad (\text{Eq. B4.1.3-2})$$

$$\phi = 0.90$$

- (c) For LSD, the *factored moment resistance* shall be determined as follows:

For gravity,

$$M_u = \phi M_{ng} \quad (\text{Eq. B4.1.3-3})$$

$$\phi = 0.85$$

B4.2 Shear

Shear alone need not be considered for the design of L-*header* beams that are fabricated and installed in accordance with this standard.

B4.3 Web Crippling

Web crippling alone need not be considered for the design of L-*header* beams that are fabricated and installed in accordance with this standard.

B4.4 Bending and Shear

The combination of bending and shear need not be considered for the design of L-*header* beams fabricated and installed in accordance with this standard.

B4.5 Bending and Web Crippling

The combination of bending and web crippling need not be considered for the design of L-*header* beams fabricated and installed in accordance with this standard.

B5 Inverted L-Header Assemblies

- (a) The provisions of this section shall be limited to inverted double or single *L-headers* satisfying the limitations defined in Section B3 for double *L-headers* and B4 for single *L-headers*, respectively.

For double *L-headers*, the *nominal flexural strength* [moment *resistance*] of the combined *L-header* assembly; i.e., *L-header* plus inverted *L-header*, shall be determined by summing the gravity and uplift *nominal flexural strengths* [moment *resistances*] as determined in accordance with Section B3.1.

For single *L-headers*, the *nominal flexural strength* [moment *resistance*] of the combined *L-header* assembly; i.e., *L-header* plus inverted *L-header*, shall be based on the gravity *nominal flexural strength* [moment *resistance*] as determined in accordance with Section B4.1.

Shear, web crippling, bending and shear, and bending and web crippling need not be considered for the design of inverted *L-headers* fabricated and installed in accordance with this standard.

C. INSTALLATION

Headers shall be installed in accordance with AISI S200 and the requirements of Sections C1, C2 and C3, as applicable.

C1 Back-to-Back and Box Headers

Back-to-back and box headers shall be installed in accordance with Figures C1-1 and C1-2, respectively. For box headers, it shall be permitted to connect track flanges to the webs of C-shape sections using 1-inch (25.4 mm) fillet welds spaced at 24 inches (610 mm) on-center in lieu of No. 8 screws.

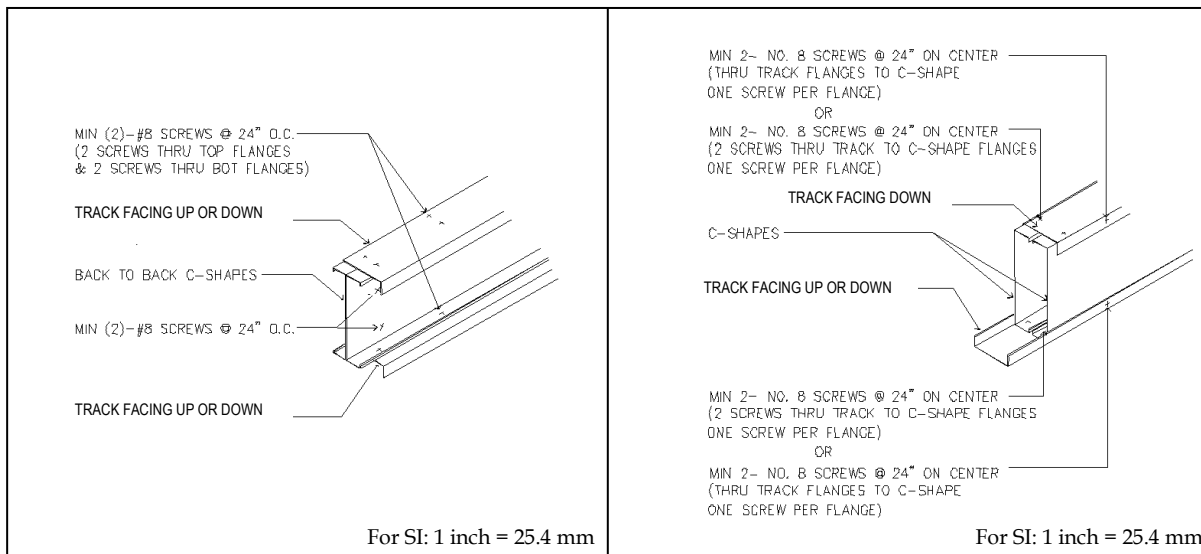

Figure C1-1 Back-to-Back Header

Figure C1-2 Box Header

C2 Double and Single L-Headers

Double and single L-headers shall be installed in accordance with Figures C2-1 and C2-2, respectively.

C3 Inverted L-Header Assemblies

Inverted double or single L-headers shall be installed in accordance with the following:

- (1) The horizontal leg of the inverted L-header shall be coped to permit the vertical leg to lap over at least one bearing stud at each end. The horizontal leg after coping shall be within $\frac{1}{2}$ inch (12.7 mm) of the bearing stud at each end.
- (2) The horizontal leg of the inverted L-header shall be attached to the head track at each end and at 12 inches (304.8 mm) on center with minimum #8 screws.
- (3) The vertical leg of the inverted L-header shall be attached to at least one bearing stud at each end and each cripple stud with a minimum #8 screw top and bottom. The top screw in the vertical leg of the inverted L-header shall be located not more than 1 inch (25.4 mm) from the top edge of the vertical leg.

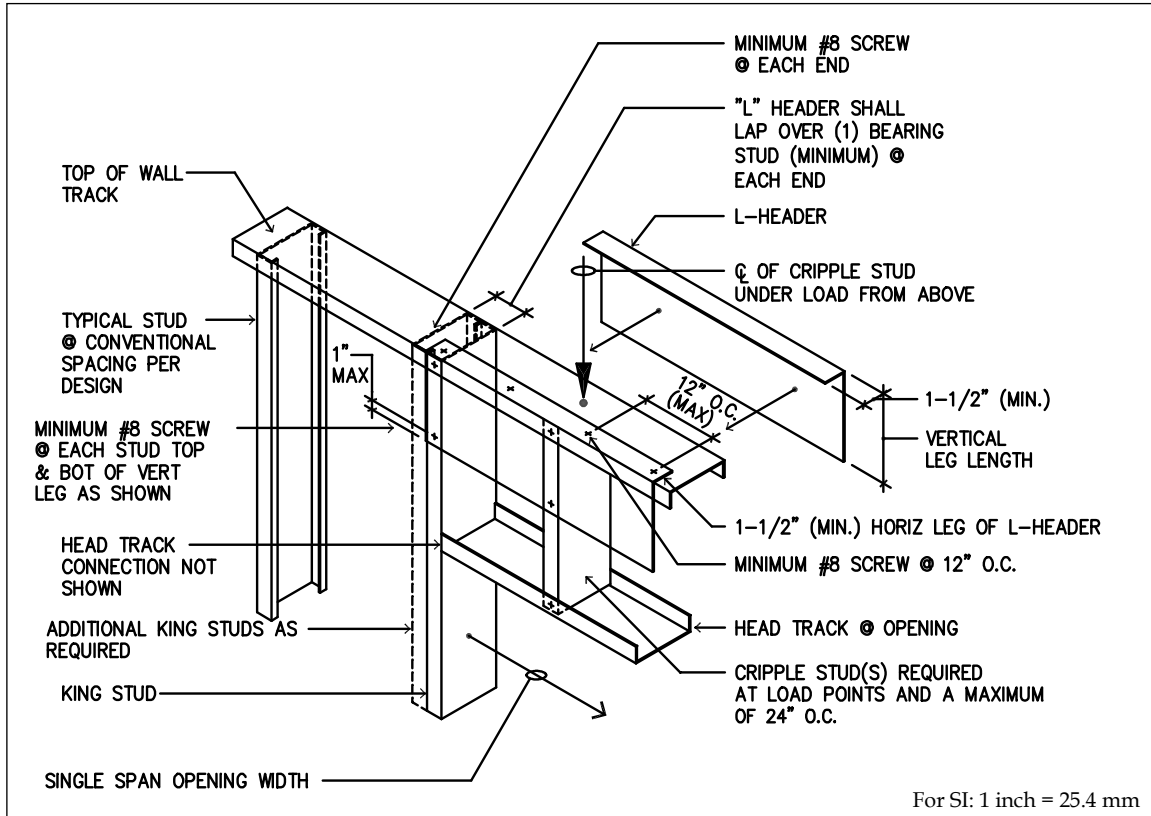

Figure C2-1 Double L-Header

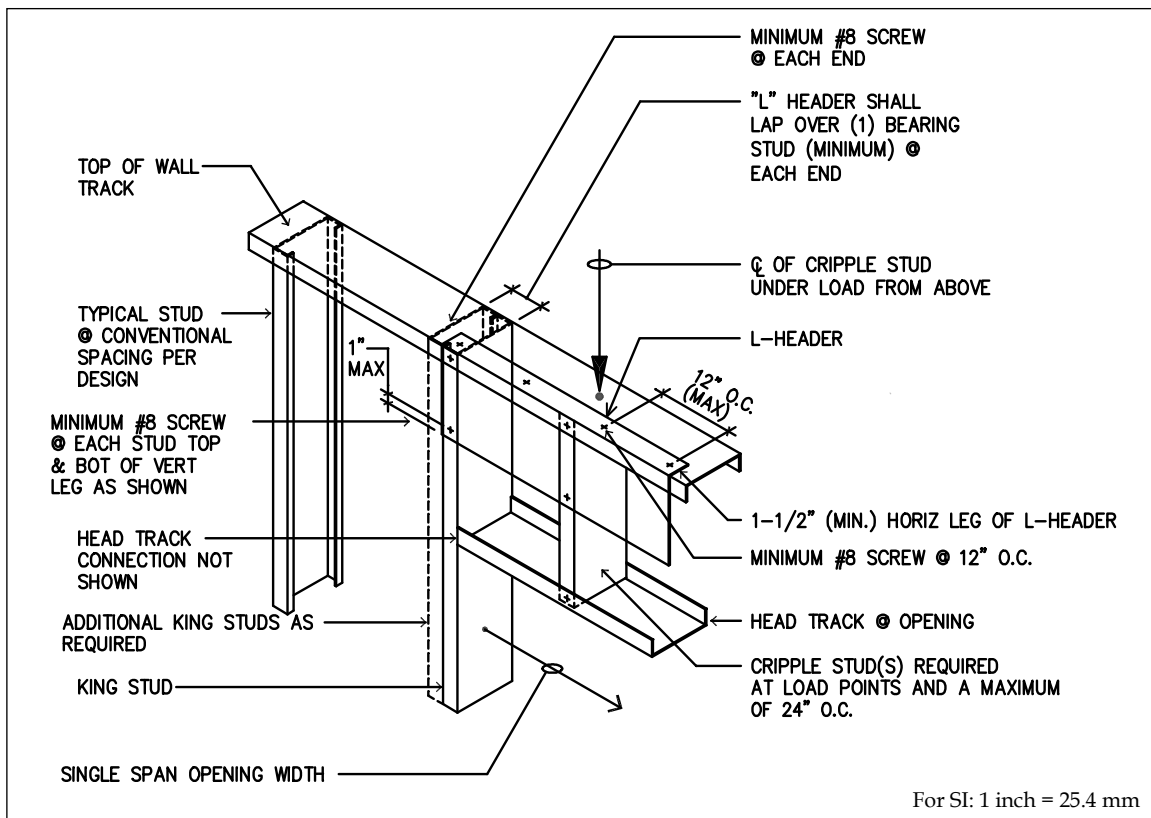

Figure C2-2 Single L-Header



AISI STANDARD

Commentary on the North American Standard for Cold-Formed Steel Framing— Header Design

2007 Edition

Revision of AISI/COFS/HD - 2004

Endorsed by



DISCLAIMER

The material contained herein has been developed by the American Iron and Steel Institute Committee on Framing Standards. The Committee has made a diligent effort to present accurate, reliable, and useful information on cold-formed steel framing design and installation. The Committee acknowledges and is grateful for the contributions of the numerous researchers, engineers, and others who have contributed to the body of knowledge on the subject. Specific references are included in this *Commentary*.

With anticipated improvements in understanding of the behavior of cold-formed steel framing and the continuing development of new technology, this material may eventually become dated. It is anticipated that AISI will publish updates of this material as new information becomes available, but this cannot be guaranteed.

The materials set forth herein are for general purposes only. They are not a substitute for competent professional advice. Application of this information to a specific project should be reviewed by a design professional. Indeed, in many jurisdictions, such review is required by law. Anyone making use of the information set forth herein does so at their own risk and assumes any and all liability arising therefrom.

1st Printing - June 2007

Copyright American Iron and Steel Institute 2007

PREFACE

This *Commentary* is intended to facilitate the use, and provide an understanding of the background, of AISI S212, the *AISI North American Standard for Cold-Formed Steel Framing – Header Design*. The *Commentary* illustrates the substance and limitations of the various provisions of the standard.

In the *Commentary*, sections, equations, figures, and tables are identified by the same notation as used in the standard. Words that are italicized are defined in AISI S200. Terms included in square brackets are specific to LSD terminology.

This Page Intentionally Left Blank

TABLE OF CONTENTS

**COMMENTARY ON THE
NORTH AMERICAN STANDARD FOR COLD-FORMED STEEL FRAMING –
HEADER DESIGN**

DISCLAIMER **ii**

PREFACE **iii**

A. GENERAL **1**

 A1 Scope 1

 A3 Loads and Load Combinations 1

B. DESIGN **2**

 B1 & B2 Back-to-Back and Box Headers 2

 B3 Double L-Headers 2

 B4 Single L-Headers 4

 B5 Inverted L-Headers 5

REFERENCES **6**

This Page Intentionally Left Blank

COMMENTARY ON THE NORTH AMERICAN STANDARD FOR COLD-FORMED STEEL FRAMING – HEADER DESIGN

A. GENERAL

Box and back-to-back *header* beams have been commonly used in *cold-formed steel* framing. The geometry is fabricated using two *C-shaped cold-formed steel* members. Design practice for such *header* beams can be based on AISI S100 [CSA S136], (AISI, 2007a; CSA, 2007). Research has determined that the application of AISI S100 [CSA S136] design provisions is conservative when *track* members are included in the assembly. This led to the development of an improved design methodology.

L-header beam geometries are gaining popularity in *cold-formed steel* framing. The geometry is fabricated using one or two L-shaped *cold-formed steel* members connected to a top *track* section. This geometry is commonly referred to as a single or double *L-header* because one or two angle shapes are used to create the *header*.

A1 Scope

AISI S212 (AISI, 2007b) addresses the design and installation requirements for *headers* subjected to vertical loads (i.e., gravity and uplift) that are in the plane of the wall. The standard does not attempt to provide a complete methodology for the design of openings in buildings. For such, the designer must consider numerous loading and serviceability issues, including out-of-plane loads, and design a complete load path consisting of members and connections that may include *cripple studs*, *jack studs*, *king studs*, *head tracks* and *sill tracks*. A useful reference for designers on this subject is the *AISI Cold-Formed Steel Framing Design Guide* (AISI, 2002).

A3 Loads and Load Combinations

Currently, *ASCE 7* (ASCE, 2006) has no geographical-based information on Mexico. Therefore, users with projects in the Mexico should work with the appropriate authority having jurisdiction to determine appropriate loads and load combinations that are consistent with the assumptions and rationale used by *ASCE 7*.

B. DESIGN

B1 & B2 Back-to-Back and Box Headers

The design methodology is based on the review and analysis of the data presented in the NAHB report *Cold-Formed Steel Back-To-Back Header Assembly Tests* (1997) and the study of Stephens (2000, 2001). The test results were evaluated and compared with the strength equations contained in AISI S100 [CSA S136], (AISI, 2007a; CSA, 2007).

Stephens and LaBoube (2000) concluded that web crippling or a combination of bending and web crippling is the primary factor in *header* beam design for the IOF (interior-one-flange) loading condition. Neither pure shear nor combined bending and shear were failure modes in the test program. The research study showed that using AISI S100 [CSA S136] web crippling equations for shapes having single *webs* for the design of box or back-to-back *header* beams would give conservative results.

Based on additional studies conducted by Stephens (2001), a modification factor was derived that enable the computation of the interior-one-flange web crippling capacity of a box *header* assembly as defined by Figure A1.1.1-2 of the standard. The increased web crippling capacity is attributed to the interaction of the *track* section and the *C-shaped* section, thus it is imperative that the *track* section be attached with the *flanges* as shown in Figure A1.1.1-2. This interaction is quantified by the ratio of *track* thickness to *C-shaped* section thickness in Eq. B2.3-1. When computing the web crippling capacity for a *header* assembly, the nominal capacity computed using AISI S100 [CSA S136] is to be multiplied by 2 to reflect that there are two *webs* in the assembly. In addition to a modification to the pure web crippling strength, the standard also contains an interaction equation for bending and web crippling of box *header* assemblies that differs from AISI S100 [CSA S136]. This interaction equation is based on the research of Stephens (2001). The research of Stephens (2001) included test specimens having standard perforations. Thus, the provisions of AISI S100 [CSA S136] are appropriate for *header* design.

If the top *track* section of a box *header* assembly is attached with the *flanges* up, as would be the case where the *header* beam is located directly above the opening and beneath the *cripple studs*, the provisions of Section B2.3 would not apply. Web crippling capacity and the combination of bending and web crippling should be evaluated by using Sections C3.4 and C3.5 of AISI S100 [CSA S136] and the equations for shapes having single unreinforced *webs* should be used.

The procedure to calculate the vertical deflection of a box or back-to-back *header* may be accomplished by using a composite assembly calculation, which would include the two *C-shaped* sections and the top and bottom *tracks*. However, to achieve full composite action using this type of calculation would require an extensive (cost prohibitive) fastener requirement between the *tracks* and the *C-shaped* sections, and therefore, it is more common to use a conservative estimate of the vertical deflection based on the full moment of inertia of the two *C-shaped* sections alone.

B3 Double L-Headers

The available test data (Elhadj and LaBoube, 2000 and LaBoube, 2004) indicated that the failure mode was flexure or combination of flexure and web crippling. Neither pure shear nor combined bending and shear were failure modes in the test program. The tested moment capacity, M_t , was determined and compared with the computed moment capacity as defined by

Section C3.1.1(a) of AISI S100 [CSA S136]. The nominal moment capacity was computed using the following equation:

$$M_n = S_{xc} F_y$$

where

F_y = measured yield stress

S_{xc} = elastic section modulus of the effective section computed at $f = F_y$.

The section modulus of the compression *flange* was used for all computations.

It should be noted that the flexural capacity is based on the section modulus of the compression *flange*; i.e., yielding of the shorter, horizontal leg of the angle. The inelastic reserve capacity of the longer, vertical leg is recognized and yielding in the extreme tensile fiber is not considered a limit state.

It should also be noted that when the design provisions of the standard were developed, the elastic section modulus of the effective section was computed assuming that when the free edge of the element was in tension, Equations B2.3-3, B2.3-4 and B2.3-5 of AISI S100 [CSA S136] would apply regardless of the magnitude of h_0/b_0 . Therefore, these assumptions are appropriate when calculating the elastic section modulus of the effective section using the standard.

For typical *L-headers* having a geometry as defined by the limitations of Section A1.1.2, the performance of full-scale double *L-header* beam tests (Elhajj and LaBoube, 2000 and LaBoube, 2004) has shown that the limit states of shear, web crippling, bending and shear, and bending and web crippling need not be considered when designing an *L-header* beam. This is because shear and web crippling failures were not indicated in any of the tests, and because a simplified conservative design approach is used. Web crippling is effectively prevented by the way *L-headers* are assembled. However, designers are cautioned that an *L-header* could potentially fail in shear for the combination of a very short span and a very large loading. Currently there are no limitations prescribed on minimum lengths or other factors that would prohibit shear failure in such cases. However, as a suggested procedure shear should probably be considered when the span-to-depth ratio is less than 3.

The procedure to calculate the vertical deflection of an *L-header* is undefined because the *L-header* is an indeterminate assembly consisting of two angles, *cripple studs*, and *track* sections interconnected by self-drilling screws. However, the test results indicate that the measured assembly deflections at an applied load that equaled the *nominal load* [*specified load*], was less than $L/240$. Further analytical work, based on test data, would be necessary in order to develop a calculation procedure to determine the deflection of *L-header* beams.

B3.1.1 Gravity Loading

The test results summarized by Elhajj and LaBoube (2000) and LaBoube (2004) are considered to be confirmatory tests that show AISI S100 [CSA S136] Section C3.1.1 provides an acceptable determination of the nominal moment capacity.

For the 10 inch (254 mm) deep *L-header* beams having the span to vertical leg dimension, L/L_v , greater than 10, the tested *header* sections had tested moment capacities greater than the computed moment capacity defined by Eq. B3.1.1-1 in the standard. However, for 10 inch (254 mm) deep beams having L/L_h ratios less than 10, the tested moment capacity was on the average ten percent less than the computed

moment capacity (Elhadj and LaBoube, 2000). Thus, the application of Eq. B3.1.1-1 is questionable for full range of the 10 inch (254 mm) *L-headers*. A review of the data indicates that the application of Eq. B3.1.1-1 is valid for test specimens having a span to vertical leg dimension, L/L_h , of 10 or greater. For the specimens having L/L_h ratios less than 10 it is proposed that the results obtained by using Eq. B3.1.1-1 be multiplied by 0.9.

B3.1.2 Uplift Loading

A comparison of the tested to computed moment capacity ratios ranged from 0.141 to 0.309 with a mean of 0.215 (Elhadj and LaBoube, 2000). Further analysis of the tested to computed moment ratios indicated that the behavior was influenced by the ratio of L_h/t . Therefore, uplift reduction factors, R , in the standard were developed as a function of the L_h/t ratio.

Based on the provisions of Chapter F of AISI S100 [CSA S136], the factor of safety was computed to be 2.0.

B4 Single L-Headers

Prior to 2003, the standard excluded single *L-headers*. The NAHB Research Center study that was completed prior to 2003 tested both single and double *L-header* beams. The tests consisted of either a single point load or a two-point load. All angles had a 1.5 inch (38.1 mm) top *flange*. The vertical leg dimensions were either 6, 8, or 10 inches (152, 203 or 254 mm). Thicknesses ranged from nominally 0.033 to 0.068 inches (0.84 to 1.73 mm). Test span lengths ranged from 36 to 192 inches (914 to 4880 mm).

An analysis of the data indicated that the behavior of the *L-headers* differed for single versus double angle geometries. Also, the single point load produced test results that differed from the two-point load. Prior to 2003, there was insufficient data to develop design guidelines for single angle *L-headers*. Thus, the data analysis did not consider data for the single angle sections nor for the single point loading.

In 2003, testing was completed at the NAHB Research Center on single *L-header* beams. The tests were similar to the previously tested double *L-header* beam tests, but *header* sizes were limited to vertical leg dimensions of 6 and 8 inches (152 or 203 mm), thicknesses ranged from nominally 0.033 to 0.054 inches (0.84 to 1.37 mm) and spans were limited to 4 feet (1.219 m). From this testing, sufficient data was provided to develop design guidelines for single *L-headers* within the range of parameters tested.

LaBoube (2004), based on testing by the NAHB Research Center (2003), demonstrated that the design methodology for double *L-headers* in the 2001 standard was acceptable for evaluating the gravity moment capacity of single *L-headers*, within the limitations of the test program. Uplift tests on single *L-headers* were not performed as part of this test program; however, Section B4.1.2 has been reserved in the standard for this eventuality. Further, using the provisions of Chapter F1 of AISI S100 [CSA S136], the same Ω and ϕ factors that were prescribed in the 2001 standard for the design of double *L-headers* would apply to single *L-headers*. As with previously tested double *L-headers*, neither pure shear nor combined bending and shear were failure modes for the tested single *L-headers*. Also, web crippling and combined bending and web crippling would be precluded from occurring because of the requirement that concentrated load applications occur at cripple stud locations.

B5 Inverted L-Headers

In 2005, provisions for inverted *L-headers*, as shown in Figure B5-1, were added to the standard, based on rational engineering judgment, as a means to provide improved capacity for double and single *L-headers*.

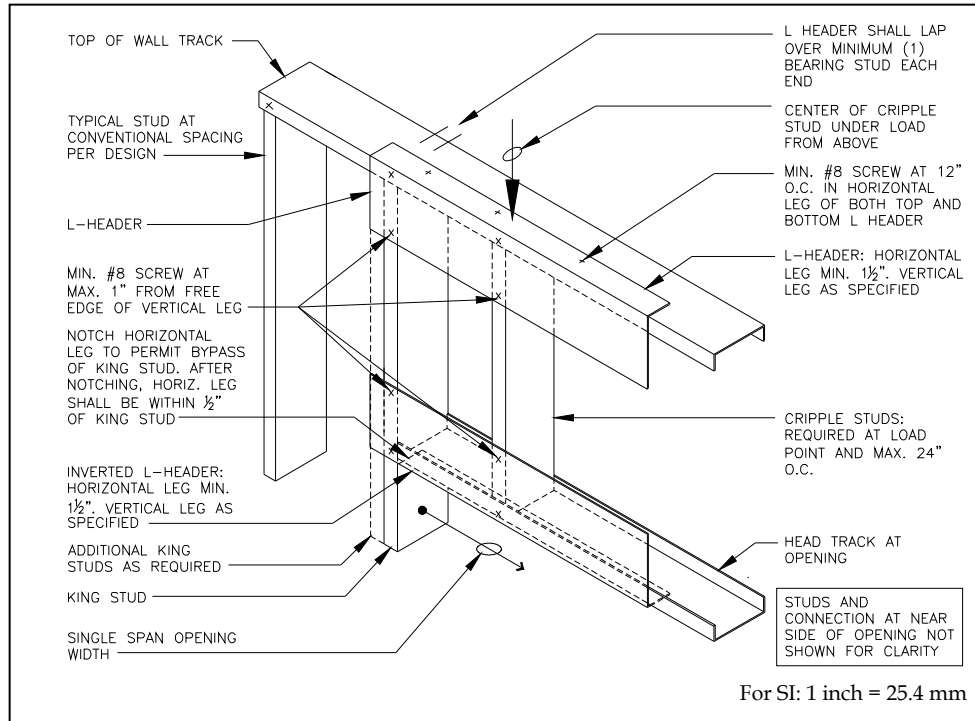

Figure B5-1 Inverted Single or Double L-Header Assembly (Single L-Header Shown)

REFERENCES

- (AISI, 1997), *Cold-Formed Steel Back-To-Back Header Assembly Tests*, Publication RG-9719, American Iron and Steel Institute, Washington, D.C., 1997.
- (AISI, 2002), *Cold-Formed Steel Framing Design Guide*, American Iron and Steel Institute, Washington, D.C., 2002.
- (AISI, 2007a), *North American Specification for the Design of Cold-Formed Steel Structural Members*, AISI S100-07, American Iron and Steel Institute, Washington, D.C., 2007.
- (AISI, 2007b), *North American Standard for Cold-Formed Steel Framing – Header Design*, AISI 212-07, American Iron and Steel Institute, Washington, D.C., 2007.
- (ASCE, 2006), *Minimum Design Loads for Buildings and Other Structures*, ASCE 7-05 Including Supplement No. 1, American Society of Civil Engineers, Reston, VA, 2006.
- (CSA, 2004), *North American Specification for the Design of Cold-Formed Steel Structural Members*, 2001 Edition with 2004 Supplement, CAN/CSA-S136-01 with CAN/CSA-S136S1-04, Canadian Standards Association, Mississauga, Ontario, Canada, 2004.
- Elhajj, N.R., and LaBoube, R. A. (2000), "L-Header Testing, Evaluation and Design Methodology," *Proceedings of the 15th International Specialty Conference on Cold-Formed Steel Structures*, Department of Civil Engineering University of Missouri-Rolla, Rolla, MO, 2000.
- LaBoube, R. A. (2004), "Strength of Single L-Headers", Summary Report, Wei-Wen Yu Center for Cold-Formed Steel Structures, Department of Civil Engineering University of Missouri-Rolla, Rolla, MO, 2004.
- (NAHB-RC, 2003), "Testing of Steel Single L-Headers", NAHB Research Center, Upper Marlboro, MD, 2003.
- Stephens, S.F., and LaBoube, R.A. (2000), "Structural Behavior of Cold-Formed Steel Header Beams for Residential Construction," *Proceedings of the 15th International Specialty Conference on Cold-Formed Steel Structures*, Department of Civil Engineering University of Missouri-Rolla, Rolla, MO, 2000.
- Stephens, S.F. (2001), "Behavior of Cold-Formed Steel Header Beams," Ph.D. dissertation, University of Missouri-Rolla, Rolla, MO, 2001.



**American
Iron and Steel
Institute**

25 Massachusetts Avenue, NW
Suite 800
Washington, DC 20001
www.steel.org



Steel Framing Alliance™

25 Massachusetts Avenue, NW
Suite 800
Washington, DC 20001
www.steel framing.org

