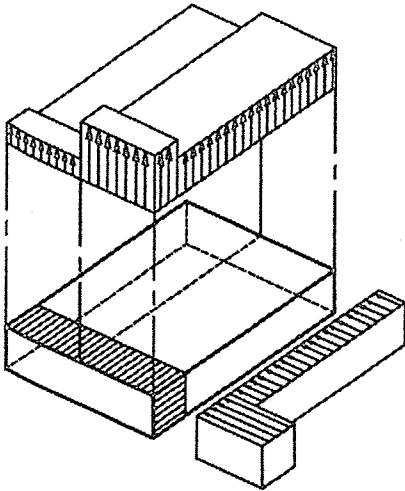


# *Guide to the Use of the Wind Load Provisions*



# *Guide to the Use of the Wind Load Provisions of ASCE 7-02*

Kishor C. Mehta  
James Delahay

**ASCE**  
**PRESS**

Cataloging-in-publication data on file with the Library of Congress.

## Authors' Disclaimer

Although the authors have done their best to ensure that any advice, recommendation, interpretation, or information given herein is accurate, no liability or responsibility of any kind (including liability for negligence) is accepted by the authors.

Published by the American Society of Civil Engineers  
1801 Alexander Bell Drive  
Reston, VA 20191  
www.asce.org

The material presented in this publication has been prepared in accordance with generally recognized engineering principles and practices, and is for general information only. This information should not be used without first securing competent advice with respect to its suitability for any general or specific application.

The contents of this publication are not intended to be and should not be construed to be a standard of the American Society of Civil Engineers (ASCE) and are not intended for use as a reference in purchase of specifications, contracts, regulations, statutes, or any other legal document.

No reference made in this publication to any specific method, product, process, or service constitutes or implies an endorsement, recommendation, or warranty thereof by ASCE.

ASCE makes no representation or warranty of any kind, whether express or implied, concerning the accuracy, completeness, suitability, or utility of any information, apparatus, product, or process discussed in this publication, and assumes no liability therefore.

Anyone utilizing this information assumes all liability arising from such use, including but not limited to infringement of any patent or patents.

ASCE and American Society of Civil Engineers—Registered in U.S. Patent and Trademark Office.

Photocopies: Authorization to photocopy material for internal or personal use under circumstances not falling within the fair use provisions of the Copyright Act is granted by ASCE to libraries and other users registered with the Copyright Clearance Center (CCC) Transactional Reporting Service, provided that the base fee of \$18.00 per chapter plus \$.50 per page is paid directly to CCC, 222 Rosewood Drive, Danvers, MA 01923. The identification for ASCE Books is 0-7844-0703-7/04/\$18.00 + \$.50 per page. Requests for special permission or bulk copying should be addressed to Permissions & Copyright Department, ASCE.

Copyright © 2004 by the American Society of Civil Engineers.  
All Rights Reserved.

ISBN 0-7844-0703-7  
Manufactured in the United States of America.

# Contents

List of Figures .....	vii
List of Tables .....	ix
Preface .....	xiii
Acknowledgments .....	xiii
<b>1. Introduction.....</b>	<b>1</b>
1.1 Objective of the Guide .....	2
1.2 Significant Changes .....	2
1.3 Limitations of Standard.....	3
1.4 Technical Literature .....	4
<b>2. Wind Load Provisions .....</b>	<b>6</b>
2.1 Format .....	6
2.2 Design Procedures.....	6
2.3 Method 3, Wind Tunnel Procedure.....	10
2.4 Equations for Graphs.....	10
<b>3. Examples.....</b>	<b>17</b>
3.1 Example 1: 30-ft × 60-ft × 15-ft Commercial Building with Concrete Masonry Unit Walls .....	18
3.2 Example 2: Ex. 1 Using Simplified Procedure.....	24
3.3 Example 3: 100-ft × 200-ft × 160-ft-High Office Building .....	26
3.4 Example 4: Office Building of Ex. 3 Located on an Escarpment .....	37
3.5 Example 5: 2,500-ft <sup>2</sup> House with Gable/Hip Roof .....	39
3.6 Example 6: 200-ft × 250-ft Gable Roof Commercial/Warehouse Building Using Buildings of All Height Provisions .....	47
3.7 Example 7: Building of Ex. 6 Using Low-Rise Building Provisions .....	59
3.8 Example 8: 40-ft × 80-ft Commercial Building with Monoslope Roof with Overhang.....	66
3.9 Example 9: U-Shaped Apartment Building .....	78
3.10 Example 10: 50-ft × 20-ft Billboard Sign on Poles (Flexible) 60 ft Above Ground .....	88
3.11 Example 11: Domed Roof Building .....	93
3.12 Example 12: Unusually Shaped Building.....	100
<b>4. Frequently Asked Questions .....</b>	<b>110</b>
References.....	119
Index.....	123

# List of Figures

3-1	Building Dimensions for Examples 1 and 2 . . . . .	18
3-2	Design Pressures for MWFRS when Wind is Normal to 30-ft Wall . . . . .	21
3-3	Design Pressures for MWFRS when Wind is Normal to 60-ft Wall . . . . .	21
3-4	Load Case 3 . . . . .	22
3-5	Design Wind Pressure . . . . .	25
3-6	100-ft × 200-ft × 160-ft Building . . . . .	27
3-7	Pressures for MWFRS for Wind Normal to the 200-ft Face . . . . .	33
3-8	Pressures for MWFRS for Wind Normal to 100-ft Face . . . . .	33
3-9	Pressures in Case B for MWFRS for Wind Normal to 100-ft Face . . . . .	34
3-10	Office Building on Escarpment. . . . .	37
3-11	a, View of Roof of 2,500-ft <sup>2</sup> House; b, Front View D; c, Side View A; d, Side View C. . . . .	40
3-12	Combinations of Wind Directions . . . . .	45
3-13	Dimensions and Framing of the Building of Examples 6 and 7 . . . . .	48
3-14	Net Design Wind Pressures for MWFRS when Wind is Normal to Ridge with Negative Windward External Roof Pressure Coefficient . . . . .	51
3-15	Net Design Wind Pressures for MWFRS when Wind is Normal to Ridge with Positive Windward External Roof Pressure Coefficient . . . . .	52
3-16	Net Design Wind Pressures for MWFRS when Wind is Parallel to Ridge with Positive Internal Pressure. . . . .	54
3-17	Net Design Wind Pressures for MWFRS when Wind is Parallel to Ridge with Negative Internal Pressure. . . . .	55
3-18A	Combined Uplift and Axial Design Loads on Interior Strut Purlin. . . . .	58
3-18B	Eave Strut Purlin Supports Roof and Wall Panels . . . . .	58
3-19	Design Pressures for Transverse Direction with Positive Internal Pressure . . . . .	62
3-20	Design Pressures for Transverse Direction with Negative Internal Pressure . . . . .	63
3-21	Design Pressures for Longitudinal Direction with Positive Internal Pressure . . . . .	63

3-22	Design Pressures for Longitudinal Direction with Negative Internal Pressure . . . . .	63
3-23	Torsional Load Case for Transverse Direction with Positive Internal Pressure . . . . .	64
3-24	Torsional Load Case for Transverse Direction with Negative Internal Pressure . . . . .	65
3-25	Torsional Load Case for Longitudinal Direction with Positive Internal Pressure . . . . .	65
3-26	Torsional Load Case for Longitudinal Direction with Negative Internal Pressure . . . . .	65
3-27	Dimensions of the Retail Store Strip-Mall . . . . .	66
3-28	Design Pressures for MWRFS; Wind Parallel to Roof Slope, Normal to 15-ft Wall, and Positive Internal Pressure a., External Pressures; b., Positive Internal Pressure; c., Combined External and Positive Internal Pressure . . . . .	71
3-29	Design Pressures for MWRFS; Wind Parallel to Roof Slope, Normal to 15-ft Wall and Negative Internal Pressure a., External Pressures; b., Negative Internal Pressure; c., Combined External and Negative Internal Pressure . . . . .	72
3-30	Combined Design Pressures for MWRFS; Wind Parallel to Roof Slope (Normal to 25-ft Wall) . . . . .	73
3-31	Combined Design Pressures for MWRFS; Wind Perpendicular to Roof Slope (Parallel to Ridge Line) . . . . .	73
3-32	Design Pressures for Typical Joists and Pressure Zones for Roof Components and Cladding . . . . .	77
3-33	240-ft × 170-ft U-shaped Apartment Building . . . . .	78
3-34	Surface Designations . . . . .	82
3-35	Design Wind Load Cases for Wind Normal to Wall W2 and W3 . . . . .	85
3-36	Component and Cladding Wall Pressure Zones . . . . .	87
3-37	Component and Cladding Roof Pressure Zones . . . . .	88
3-38	Dimensions of a Billboard Sign on an Interstate Highway . . . . .	89
3-39	Design Forces for the Billboard Sign . . . . .	93
3-40	100-ft Diameter Domed Roof Building . . . . .	94
3-41	MWFRS External Pressures . . . . .	97
3-42	Component Design Pressures . . . . .	99
3-43	100-ft × 100-ft Unusually Shaped Building . . . . .	100
3-44	External Roof Pressure Zones for MWFRS . . . . .	105
3-45	Application of 10-psf Minimum Load Case . . . . .	105
3-46	Application of Load Case 1 from Each Orthogonal Direction . . . . .	106
3-47	Application of Load Case 3 from Each Diagonal Direction . . . . .	107
3-48	Component and Cladding Wall Pressure Zones . . . . .	109
3-49	Component and Cladding Roof Pressure Zones . . . . .	109

# List of Tables

1-1	Technical Literature .....	5
2-1	Walls for Buildings with $h \leq 60$ ft (Figure 6-11A) .....	11
2-2	Gable Roofs with $h \leq 60$ ft, $\theta \leq 7^\circ$ (Figure 6-11B) .....	11
2-3	Gable and Hip Roofs with $h \leq 60$ ft, $7^\circ < \theta \leq 27^\circ$ (Figure 6-11C) .....	12
2-4	Gable Roofs with $h \leq 60$ ft, $27^\circ < \theta \leq 45^\circ$ (Figure 6-11D) .....	12
2-5	Multispan Gabled Roofs with $h \leq 60$ ft, $10^\circ < \theta \leq 30^\circ$ (Figure 6-13) .....	13
2-6	Multispan Gable Roofs with $h \leq 60$ ft, $30^\circ < \theta \leq 45^\circ$ (Figure 6-13) .....	13
2-7	Monoslope Roofs with $h \leq 60$ ft, $3^\circ < \theta \leq 10^\circ$ (Figure 6-14A) ...	14
2-8	Monoslope Roofs with $h \leq 60$ ft, $10^\circ < \theta \leq 30^\circ$ (Figure 6-14B) ...	14
2-9	Sawtooth Roofs with $h \leq 60$ ft (Figure 6-15) .....	15
2-10	Roofs and Walls for Buildings with $h > 60$ ft (Figure 6-17) .....	16
3-1	Design Wind Pressures .....	25
3-2	$q_z$ Velocity Pressures .....	28
3-3	Wall $C_p$ for Ex. 3 .....	29
3-4	Roof $C_p$ for Wind Normal to 200-ft Face .....	30
3-5	Roof $C_p$ for Wind Normal to 100-ft Face .....	30
3-6	External Pressures for MWFRS: Wind Normal to 200-ft Face ...	31
3-7	External Pressures for MWFRS: Wind Normal to 100-ft Face ...	31
3-8	Wall ( $GC_p$ ) for Ex. 3 .....	34
3-9	Controlling Design Pressures for Mullions (psf) .....	35
3-10	Design Pressures of Panels (psf) .....	35
3-11	Roof External Pressure Coefficient ( $GC_p$ ) .....	36
3-12	Roof Design Pressures (psf) .....	36
3-13	Speed-up Velocity Pressures (psf) .....	38
3-14	Velocity Pressure $q_z$ (psf) .....	39
3-15	Roof $C_p^*$ for Wind Direction A .....	41
3-16	Roof $C_p$ for Wind Direction B .....	43
3-17	Velocity Pressures (psf) .....	49
3-18	External Wall $C_p$ .....	50
3-19	Roof $C_p$ (Wind Normal to Ridge) .....	50

3-20	MWFRS Pressures: Wind Normal to Ridge .....	51
3-21	Roof $C_p$ (Wind Parallel to Ridge) .....	53
3-22	MWFRS Pressures: Wind Parallel to Ridge .....	53
3-23	Wall Coefficients ( $GC_p$ ) in Figure 6-11A .....	54
3-24	Net Controlling Wall Component Pressures (psf) .....	55
3-25	Roof Coefficients ( $GC_p$ ) in Figure 6-11C; $7^\circ < \theta < 27^\circ$ .....	56
3-26	Net Controlling Roof Component Pressures (psf) .....	57
3-27	Transverse Direction ( $\theta = 18.4^\circ$ ) .....	61
3-28	Longitudinal Direction ( $\theta = 0^\circ$ ) .....	61
3-29	Design Wind Pressures, Transverse Direction .....	61
3-30	Design Wind Pressures, Longitudinal Direction .....	61
3-31	Design Wind Pressure for Zone "T," Transverse Direction .....	64
3-32	Design Wind Pressure for Zone "T," Longitudinal Direction .....	64
3-33	Velocity Pressures, $q_w$ , $q_v$ and $q_h$ (psf) .....	67
3-34	Wall Pressure Coefficients ( $C_p$ ) .....	69
3-35	Roof Pressure Coefficients ( $C_p$ ) .....	69
3-36	Design Pressures for MWFRS: Wind Parallel to Roof Slope (normal to ridge line) .....	70
3-37	Design Pressures for MWFRS: Wind Normal to Roof Slope (parallel to ridge line) .....	74
3-38	Wall External Pressure Coefficients ( $GC_p$ ) .....	74
3-39	Wall Design Pressures (psf) .....	75
3-40	Roof External Pressure Coefficients ( $GC_p$ ), $\theta = 14^\circ$ .....	76
3-41	Roof Design Pressures (psf) .....	76
3-42	$q_z$ Velocity Pressures .....	79
3-43	External Pressure Coefficients ( $C_p$ ) for Wind Normal to Wall W2 .....	80
3-44	External Pressure Coefficients ( $C_p$ ) for Wind Normal to Wall W4 .....	81
3-45	External Pressure Coefficients ( $C_p$ ) for Wind Normal to Wall W3 .....	81
3-46	External Pressure Coefficients ( $C_p$ ) for Wind Normal to Wall W1-W7-W5 .....	81
3-47	External Pressures for Wind Normal to Wall W2 .....	83
3-48	External Pressures for Wind Normal to Wall W4 .....	84
3-49	External Pressures for Wind Normal to Wall W3 .....	84
3-50	External Pressures for Wind Normal to Wall W1-W7-W5 .....	85
3-51	Wall ( $GC_p$ ) for Ex. 9 .....	86
3-52	Controlling Design Pressures for Wall Components (psf) .....	86
3-53	Roof External Pressure Coefficients ( $GC_p$ ) .....	87
3-54	Roof Design Pressures (psf) .....	88
3-55	Velocity Pressures (psf) .....	89
3-56	$q_z$ Velocity Pressures .....	95
3-57	Domed Roof $C_p$ (at $f/D = 0.30$ ) .....	96

3-58	Interpolated Domed Roof $C_p$ (Case A)	96
3-59	Interpolated Domed Roof $C_p$ (Case B)	96
3-60	Domed Roof Design Pressures for MWFRS (psf)	98
3-61	Roof External Pressure Coefficient ( $GC_p$ ) from Figure 6-16	99
3-62	Roof Design Pressures (psf)	99
3-63	$q_z$ Velocity Pressures	101
3-64	External Pressure Coefficients ( $C_p$ ) for Wind Normal to Wall W1	102
3-65	External Pressure Coefficients ( $C_p$ ) for Wind Normal to Wall W5	102
3-66	External Pressure Coefficients ( $C_p$ ) for Wind Normal to Wall W4	102
3-67	External Pressure Coefficients ( $C_p$ ) for Wind Normal to Wall W2	102
3-68	Design Pressures for Wind Normal to Wall W1	103
3-69	Design Pressures for Wind Normal to Wall W5	103
3-70	Design Pressures for Wind Normal to Wall W4	104
3-71	Design Pressures for Wind Normal to Wall W2	104
3-72	Wall ( $GC_p$ ) for Ex.12	107
3-73	Controlling Design Pressures for Wall Components (psf)	108
3-74	Roof External Pressure Coefficients ( $GC_p$ )	108
3-75	Roof Design Pressures (psf)	108

# Preface

This guide is designed to assist professionals in the use of the wind load provisions of SEI/ASCE Standard 7-02, *Minimum Design Loads for Buildings and Other Structures*, published by the American Society of Civil Engineers (ASCE). The guide is a revision of the *Guide to the Use of Wind Load Provisions of ASCE 7-98*, reflecting the significant changes made to wind load provisions when the previous version of the Standard, ASCE 7-98, was updated. The guide contains 12 example problems worked out in detail, which can provide direction to practicing professionals in assessing wind loads on a variety of buildings and other structures. Every effort has been made to make these illustrative example problems correct and accurate. The authors would welcome comments regarding inaccuracies, errors, or different interpretations. The views expressed and interpretation of the wind load provisions made in the guide are those of the authors and not of the ASCE 7 Standards Committee or the ASCE organization.

# Acknowledgments

The authors wish to acknowledge the members of the ASCE 7 Minimum Design Loads for Buildings and Other Structures Standards Committee that was chaired by Dr. Jim Harris during the consensus process of ASCE 7-02. The members of the Task Committee on Wind Loads and the ASCE 7 Standards Committee contributed significantly to the final wind load provisions of the ASCE 7-02 through their questions, comments, and discussions. The authors are indebted to these 100-plus members.

In a document of this type, there are individuals in the background who helped in layout, word-processing, and checking calculations. These tasks were handled by the staff of the Wind Science and Engineering Research Center, Texas Tech University, and the authors acknowledge and appreciate the contributions of these individuals. In particular, we would like to thank Hua He, doctoral degree candidate at Texas Tech University, who performed and checked calculations for example problems and made a significant contribution to this guide; and Kevin Brown, project engineer at LBYD, Inc., who back-checked the calculations for all the example problems. The authors acknowledge and appreciate the contributions of all these individuals.

since it had the potential to establish a single wind load criterion for design of all buildings and structures for the entire United States. A *Guide to the Use of the Wind Load Provisions of ASCE 7-98* (Mehta and Perry, 2000) was published soon after publication of ASCE 7-98.

In 2003, the new standard, ASCE 7-02, was published. This guide is designed to assist practicing professionals in the use of wind load criteria of ASCE 7-02.

## 1.1 Objective of the Guide

The objective of this guide is to provide direction in the use of wind load provisions of ASCE 7-02 (referred to as “the Standard”). The Commentary of ASCE 7-02 (Section C6.0) contains a good background and discussion of the wind load criteria; that information is not repeated in this document. Rather, this guide contains two important items to assist the users of ASCE 7-02: (1) examples, and (2) Frequently Asked Questions.

The guide contains 12 worked examples. Sufficient details of calculation of wind loads are provided to help the reader properly interpret the wind load provisions of the Standard. Section 6.0 of the Standard, as well as the figures and tables of the Standard, are cited liberally in the examples. **It is necessary to have a copy of ASCE 7-02 to follow the examples and work with this Guide.** A copy of ASCE 7-02 can be ordered by calling 1-800-548-ASCE or ordered on the web at [www.pubs.asce.org](http://www.pubs.asce.org).

## 1.2 Significant Changes

The wind load provisions of Section 6.0 were revised in ASCE 7-02 using recent research and development achievements. The major changes involve expansion of the simplified procedure, load cases for main wind force-resisting systems (MWFRS), and introduction of surface roughness length to define exposure coefficients.

The basic approach to assessing wind loading has not been changed, but new parameters, such as surface roughness length, are added to provide more flexibility to designers. In addition, wind-borne debris provisions in hurricane-prone areas are specifically spelled out. Significant changes affecting the design process are listed below.

- Method 1, Simplified Procedure, is significantly revised and expanded. The requirements for using this method have been set separately for MWFRS and components and cladding (C&C). The procedure is expanded to include flat, gable, and hip roofs with roof slope up to 45° MWFRS. For C&C, the hip roof is restricted to  $\theta = 27^\circ$ . Eq. 6-1 and 6-2 permit modification for terrain and height from tabulated values, as well as for importance factor.
- For design of MWFRS, wind load cases (Figure 6-9) are applied to buildings of all heights.
- Exposure category is based on surface roughness length in each wind direction sector. The surface roughness length parameter permits interpolation of the exposure category using a rational proce-

ture. An assessment of exposure categories using word description, as previously done, is permitted.

- Distances of ground surface roughness condition in the prevailing direction are revised.
- Exposure A is deleted from the tabulated values in the Standard.
- Lower value of roof pressure coefficient is added for all roof angles to obtain minimum design pressures for MWFRS.
- Low-rise building provisions for MWFRS have been significantly revised. The load cases are clearly delineated.
- New pressure coefficients are provided to determine wind loads for domed roof buildings (see Example 11 in Section 3.11 of this guide).
- Provisions for calculating wind load for parapets (MWFRS and C&C) are added to the Standard (see Example 3 in Section 3.3 of this guide).

ASCE 7-02 incorporates the latest available technical information. As noted above, the basic methodology of the Standard remains the same as in ASCE 7-98. Additional information on the changes can be found in the Commentary of the Standard and from references.

## 1.3 Limitations of Standard

The possible shortcomings or limitations of the Standard are directly dependent on accurate knowledge of parameters and factors used in the algorithms that define the wind loads for design applications. Limitations of some of the significant parameters are discussed below.

### 1.3.1 Assessment of Wind Climate

The current Standard provides a more realistic description of wind speeds than did the previous editions of the 1970s and 1980s. Perhaps the most serious limitations are that design speeds are not referenced to direction, and potential wind speed anomalies are defined only in terms of special wind regions. These special wind regions include mountain ranges, gorges, or river valleys. Unusual winds may be encountered in these regions because of orographic effects or because of the channeling of wind. The Standard permits climatological studies using regional climatic data and consultation with a wind engineer and/or a meteorologist.

Tornado winds are not included in development of the basic wind speed map (Figure 6-1 of the Standard) because of their relatively rare occurrence at a given location. Intense tornadoes can have ground level wind speeds in the range of 150 to 200 mph; however, the annual probability of exceedance of this range of wind speeds may be less than  $1 \times 10^{-5}$  (mean recurrence interval exceeding 100,000 years). Special structures and storm shelters can be designed to resist tornado winds if required.

### 1.3.2 Limitations in Evaluating Structural Response

Given that the majority of buildings and other structures can be treated as rigid structures, the gust effect factor specified in the Standard is adequate. For dynamically sensitive buildings and other structures, a gust effect factor,  $G_f$ , is given. The formulation of gust effect factor,  $G_f$ , is primarily for build-

ings; it is not always applicable to other structures. It should be noted that the gust effect factor,  $G_f$ , is based on along-wind buffeting response.

Vortex shedding is almost always present with bluff-shaped cylindrical bodies. It can become a problem when the frequency of shedding is close to, or equal to, the frequency of the first or second transverse modes of the structure. The intensity of excitation increases with aspect ratio (height-to-width or length-to-breadth) and decreases with increasing structural damping. Structures with low damping and with an aspect ratio of 8 or more may be prone to damaging vortex excitation. If across-wind or torsional excitation appears to be a possibility, expert advice should be obtained.

Another limitation with respect to evaluating structural response is that the Standard does not define acceptable design wind speeds for serviceability states (e.g., deflection, dynamic sway). Table C6-3 in the Commentary provides conversion factors for determining appropriate wind speeds for mean recurrence intervals of 5 to 500 yr.

### 1.3.3 Limitations in Shapes of Buildings and Other Structures

The pressure and force coefficients given in the Standard are limited. Many of the structural shapes (e.g., “Y,” “T,” and “L” shapes) or buildings with stepped elevations are not included. Fortunately, this information may be found in other sources (see Table 1-1 of this guide).

When coefficients for a specific shape are not given in the Standard, the designer is encouraged to use values that are available in the literature. However, the use of prudent judgment is advised, and the following caveats must be addressed:

1. Were the coefficients obtained from proper turbulent boundary layer wind tunnel tests (BLWT), or were they generated under conditions of relatively smooth flow?
2. The averaging time used must necessarily be considered in order to determine whether the coefficients are directly applicable to the evaluation of design loads or whether they need to be modified.
3. The reference wind speed (fastest-mile, hourly mean, 10-min mean, 3-s gust, etc.) and exposure category under which the data are generated must be established in order to properly compute the velocity pressure,  $q$ .
4. If an envelope approach is used, the coefficients should be appropriate for all wind directions. If, however, a directional approach is indicated, then the applicability of the coefficients as a function of wind direction needs to be ascertained. A major limitation in the use of directional coefficients is that their adequacy for other than normal wind directions may not have been verified.

## 1.4 Technical Literature

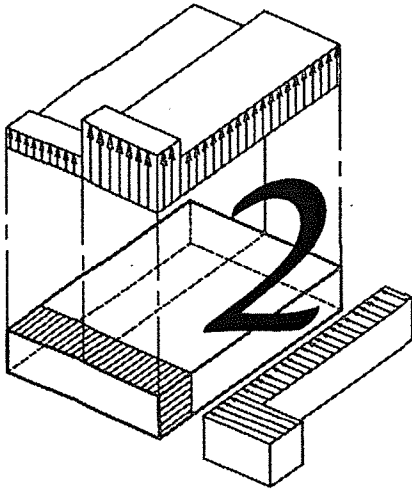
There has been a vast amount of literature published on wind engineering during the past three decades. Most of it is in the form of research papers in the *Journal of Wind Engineering and Industrial Aerodynamics*, *Journal of Structural Engineering*, *Proceedings of the International Conferences on Wind Engineering* (a total of eleven), *Proceedings of the U.S. National Conferences on Wind*

*Engineering* (a total of nine), *Proceedings of the Asia-Pacific Conferences on Wind Engineering* (a total of five), and *Proceedings of the European-African Conferences on Wind Engineering* (two). The literature is extensive and scholarly; however, it is not always in a format that can be used by practicing professionals.

Several textbooks, handbooks, standards and codes, reports, and papers contain material that can be used to determine wind loads. Selected items are identified in Table 1-1 of this guide. The items are listed by subject matter for easy identification. Detailed references for these items are given in the citations in Chapter 4, References, of this guide.

**Table 1-1** Technical Literature

<i>Subject</i>	<i>Selected reference material (see Chapter 4 of this guide)</i>
Wind effects on buildings and structures	Newberry and Eaton (1974); Lawson, vols. 1 and 2 (1980); Cook, parts 1 and 2 (1985); Holmes, Melbourne, and Walker (1990); Liu (1991); Simiu and Scanlan (1996); Holmes (2001)
Foreign codes and standards	NRCC (1995a, 1995b); British Standard BS 6399 (1995); Eurocode 1(1994); ISO (1997); Australian/New Zealand Standard AS/NZS 1170.2 (2002)
Wind tunnel testing	Reinhold (1982); ASCE (1999)
General wind research	ASCE (1961); Cermak (1977); Davenport, Surry, and Stathopoulos (1977, 1978); Simiu (1981)
Pressure and force coefficients	ASCE (1961, 1997); Hoerner (1965)
Tornadoes, shelter design	Minor, McDonald, and Mehta (1993); FEMA TR83-A (1980); Minor (1982); McDonald (1983); FEMA 320 (1999); FEMA 361 (2000)
Impact resistance protocol	SBCCI (1999); ASTM E1886-97, ASTM E1996-01; Miami/Dade County Building Code Compliance Office Protocol PA 201-94 and PA 203-94



# 2 Wind Load Provisions

## 2.1 Format

The designer is given three options for evaluating the design wind loads for buildings and other structures:

1. Method 1, Simplified Procedure, as specified in Section 6.4 of the Standard, for buildings meeting certain specific requirements. The requirements are set for main wind force-resisting system (MWFRS) and components and cladding (C&C), respectively.
2. Method 2, Analytical Procedure, of Section 6.5 of the Standard, applicable to buildings and other structures.
3. Method 3, Wind Tunnel Procedure, which meets certain test conditions as specified in Section 6.6 of the Standard.

The simplified and analytical procedures (see Sections 6.4.2 and 6.5.3, respectively) provide specific steps to be followed in the determination of wind loads on MWFRS and C&C separately. MWFRS is defined in Section 6.2 as the overall structure receiving wind loading from more than one surface. Cladding receives wind loads directly and generally transfers the load to other components or to the MWFRS. Equations for the determination of wind loads using the analytical procedures are given in the body of the text of the Standard. Some of the important notes that were given with figures and tables of the previous editions of the Standard have been moved into the body of the text.

Equations for the graphs of Figures 6-11A through 6-17 in the Standard are given in Section 2.4 of this guide because interpolation using these graphs, as presented in the Standard, is difficult.

## 2.2 Design Procedures

### 2.2.1 Velocity Pressure

The first step in using Method 2, Analytical Procedure, is to determine the appropriate parameters for evaluating the velocity pressure,  $q$ .

Velocity pressure,  $q$ , at any height above ground and at mean roof height is obtained by the following equation:

$$q_z = 0.00256K_zK_{zt}K_dV^2I \text{ (lb/ft}^2\text{)} \quad \text{(Eq. 6-15)}$$

where

- $q$  = Effective velocity pressure to be used in the appropriate equations to evaluate wind pressures for MWFRS and C&C;  $q_z$  at any height,  $z$ , above ground;  $q_h$  is based on  $K_h$  at mean roof height,  $h$
- $K_z$  = Exposure velocity pressure coefficient, which reflects change in wind speed with height and terrain roughness (see Section 6.5.5 and Table 6-3 of the Standard)
- $K_{zt}$  = Topographic factor which accounts for wind speed-up over hills and escarpments (see Section 6.5.7 and Figure 6-4 of the Standard)
- $K_d$  = Directionality factor (see Section 6.5.4.4 and Table 6-4 of the Standard)
- $V$  = Basic wind speed, which is the 3-s gust speed at 33 ft above ground for Exposure Category C and is associated with an annual probability of 0.02 (50-yr mean recurrence interval) (see Section 6.5.4 and Figure 6-1 of the Standard)
- $I$  = Importance factor, which adjusts wind speed associated with annual probability of 0.02 (50-yr mean recurrence interval) to other probabilities (25- or 100-yr MRI) (see Section 6.5.5 and Table 6-1 of the Standard)

## 2.2.2 Method 1, Simplified Procedure

Method 1 was introduced in ASCE 7-98 for simplifying evaluation of design loads for common regular-shaped buildings. In ASCE 7-02, provisions of this method are revised significantly. The restrictions for using the simplified procedure are set for MWFRS and C&C in Sections 6.4.1.1 and 6.4.1.2, respectively.

Tabulated wind pressure values are provided in Figure 6-2 for MWFRS and Figure 6-3 for C&C. For MWFRS, Method 1 combines the windward and leeward pressures into a net horizontal wind pressure on the walls (internal pressures cancel). The maximum uplift on the roof for MWFRS is based on a positive internal pressure as the controlling case and is applied on horizontal projection of the roof surface. For C&C, values are provided only for enclosed buildings and represent the net pressure (sum of external and internal pressures) applied normal to surfaces. The following values have been assumed in the preparation of the tabulated values:

- $h = 30 \text{ ft}$
- Exposure B,  $K_z = 0.70$
- $K_d = 0.85$
- $G = 0.85$
- $K_{zt} = 1.0$
- $I = 1.0$
- $G C p_i = \pm 0.18$  (enclosed building)
- MWFRS pressure coefficients from Figure 6-10
- C&C pressure coefficients from Figure 6-11A

Multiplying factor “ $\lambda$ ” is given for different mean roof heights and exposure classifications in Figures 6-2 and 6-3 of the Standard. For importance factors other than  $I = 1.0$ , tabulated pressure values should be multiplied by the appropriate value of  $I$ .

### 2.2.3 Method 2, Analytical Procedure

The analytical procedure for this method is applicable to

1. Buildings of all heights
2. Alternate low-rise buildings with mean roof height less than or equal to 60 ft and as defined in Section 6.2 of the Standard
3. Open buildings and other structures

The design procedure for each building type is delineated in Section 6.5.3 of the Standard. Velocity pressures,  $q_z$  or  $q_{hv}$  are determined in each case using Eq. 6-15 (see Section 6.5.10).

Design pressures for MWFRS and for C&C are determined separately. Generally, C&C design pressures will be higher because of localized high pressures acting over small areas. MWFRS receive wind pressures from several surfaces; hence, with spatial averaging and correlation, the pressures are likely to be smaller than those for C&C.

Calculation of design pressures requires selection of appropriate gust effect factors and pressure or force coefficients. The equation for the evaluation of wind loads guides the user in the selection of appropriate factors and coefficients. Various gust effect factors and pressure and force coefficients specified in the Standard are as follows:

- $G$  Gust effect factor for MWFRS of buildings (all heights) and for other structures (Section 6.5.8.1)
- $G_f$  Gust effect factor for MWFRS of flexible buildings and dynamically sensitive other structures obtained using the procedure given in Section 6.5.8.2 or using a rational analysis (see Section 6.5.8.3)
- $C_p$  External pressure coefficients for MWFRS of buildings: all heights (Figure 6-6); domed roof (Figure 6-7); and arched roof (Figure 6-8)
- $C_f$  Force coefficients for open buildings and other structures (Figures 6-18 through 6-22)
- $(GCp)_f$  External pressure coefficients for MWFRS of low-rise buildings (Figure 6-10)
- $(GCp)$  External pressure coefficients for C&C of buildings (Figures 6-11A through 6-17)
- $(GCp)_i$  Internal pressure coefficients for MWFRS and C&C of buildings (Figure 6-5)

Sign convention in the Standard is as follows:

- + (plus sign) means pressure acting toward the surface
- (minus sign) means pressure acting away from the surface

Whenever the sign of “ $\pm$ ” is specified, both positive and negative values should be used to obtain design loads. Values of external and internal pressures are to be combined algebraically to obtain the most critical load.

### 2.2.3.1 Design Pressures for Buildings

Design wind pressures for the MWFRS of rigid buildings of all (any) heights are determined using the following equation:

$$p = qGCp - q_i(GCp_i) \text{ (lb/ft}^2\text{)} \quad (\text{Eq. 6-17})$$

The terms in Eq. 6-17 are defined above. The effective velocity pressure related to internal pressure,  $q_p$  is generally used as  $q_h$  (see Section 6.5.12.2.1 of the Standard). Only for high-rise building may it be advantageous to use  $q_i$  as defined in Section 6.5.12.2.1 related to positive internal pressure. Use of this term is illustrated in Ex. 3 (Section 3.3 of this guide).

Alternatively, design pressures for MWFRS of low-rise buildings can be determined using the following equation:

$$p = q_h[(GCp) - (GCp_i)] \text{ (lb/ft}^2\text{)} \quad (\text{Eq. 6-18})$$

The terms in Eq. 6-18 are defined above. A low-rise building is defined in Section 6.2 of the Standard as a building with mean roof height  $h = 60$  ft and with mean roof height not exceeding the least horizontal dimension. The design pressures are applied for transverse and longitudinal directions as shown in Figure 6-10. This alternate procedure is appropriate for gable and rectangular buildings, though use of it for any building is permitted. Use of this procedure is illustrated in Ex. 7 (Section 3.7 of this guide).

Design wind pressures for the MWFRS of flexible buildings shall be determined from the following equation:

$$p = qG_fC_p - q_i(GCp_i) \text{ (lb/ft}^2\text{)} \quad (\text{Eq. 6-19})$$

where the terms are as defined above, and  $G_f$  = gust effect factor as defined in Section 6.5.8.2 of the Standard. The procedure is the same as that for rigid buildings except for determination of gust effect factor,  $G_f$ . A flexible building (or structure) is defined in Section 6.2 as the one that has fundamental natural frequency less than 1 Hz (period of vibration greater than 1 s). Flexible buildings or structures are affected by the gustiness of the wind and have potential of resonance response. This response results in a large gust effect factor. Calculation of gust effect factor,  $G_f$ , for a flexible structure using Eq. 6-8 of Section 6.5.8.2 is illustrated in Ex. 10 (Section 3.10 of this guide).

Design wind pressures on C&C elements of buildings with  $h \leq 60$  ft are determined from the following equation:

$$p = q_h[(GCp) - (GCp_i)] \text{ (lb/ft}^2\text{)} \quad (\text{Eq. 6-22})$$

The terms in Eq. 6-22 are defined above.

Design wind pressures on C&C for buildings with  $h > 60$  ft are determined from the following equation:

$$p = q(GCp) - q_i(GCp_i) \text{ (lb/ft}^2\text{)} \quad (\text{Eq. 6-23})$$

The terms in Eq. 6-23 are defined above.

An alternate procedure (see Section 6.5.12.4.3 of the Standard) to calculate design pressures on C&C for buildings with mean roof height of  $60 < h = 90$  ft is to use Eq. 6-22 and associated pressure coefficients. Since this equation, which is for buildings with  $h = 60$  ft, uses  $q_h$  for positive and negative external pressures, the resulting pressures may be higher in some cases.

If a component or cladding element has tributary area (not effective area) greater than 700 ft<sup>2</sup> (see Section 6.5.12.1.3 of the Standard), it is permitted to be designed using the provisions of MWFRS, Eq. 6-17, and associated pressure coefficients.

### 2.2.3.2 Design Wind Loads on Open Buildings and Other Structures

The design wind-force for open buildings and other structures is determined by the following equation:

$$F = q_z G C_p A_f \quad (\text{Eq. 6-25})$$

The terms of Eq. 6-25 are defined above. The area,  $A_f$ , is the exposed area projected on a plane normal to the wind direction unless it is specified with the value of force coefficient,  $C_f$ . The force,  $F$ , is in the direction of wind except when it is specified with the value of  $C_f$ .

## 2.3 Method 3, Wind Tunnel Procedure

For those situations where the analytical procedure is considered uncertain or inadequate, or where more accurate wind pressures are desired, consideration should be given to wind tunnel tests. The Standard lists a set of conditions in Section 6.6 that must be satisfied for the proper conduct of such tests. The wind tunnel is particularly useful for obtaining detailed information about pressure distributions on complex shapes and the dynamic response of structures. Model scales for structural applications can range from 1:50 for a single-family dwelling to 1:400 for tall buildings. Even smaller scales may be used to model long-span bridges. Of equal importance is the ability to model complex topography at scales of the order of 1:10,000 and assess the effects of features such as hills, mountains, or river gorges on the near-surface winds. Details on wind tunnel modeling for structural or civil engineering applications may be found in ASCE (1999), Cermak (1977), and Reinhold (1982).

## 2.4 Equations for Graphs

Figures 6-11A through 6-17 of the Standard give external pressure coefficient ( $GC_p$ ) values for C&C for buildings as a function of effective area of component and cladding. Wind tunnel results found this relationship between pressure coefficients and effective area to be a logarithmic function. The scale of effective area in the figures is a log scale, which makes it very difficult to interpolate. Equations for each of the lines in these figures are given in Tables 2-1 through 2-10, below. The equations can be used to determine wind loads.

**Table 2-1** Walls for Buildings with  $h \leq 60$  ft (Figure 6-11A)*Positive: Zones 4 and 5*

$(GC_p) = 1.0$	for $A = 10 \text{ ft}^2$
$(GC_p) = 1.1766 - 0.1766 \log A$	for $10 < A = 500 \text{ ft}^2$
$(GC_p) = 0.7$	for $A > 500 \text{ ft}^2$

*Negative: Zone 4*

$(GC_p) = -1.1$	for $A = 10 \text{ ft}^2$
$(GC_p) = -1.2766 + 0.1766 \log A$	for $10 < A = 500 \text{ ft}^2$
$(GC_p) = -0.8$	for $A > 500 \text{ ft}^2$

*Negative: Zone 5*

$(GC_p) = -1.4$	for $A = 10 \text{ ft}^2$
$(GC_p) = -1.7532 + 0.3532 \log A$	for $10 < A = 500 \text{ ft}^2$
$(GC_p) = -0.8$	for $A > 500 \text{ ft}^2$

Note: Zones are shown in the figures referenced in ASCE 7-02.

**Table 2-2** Gable Roofs with  $h \leq 60$  ft,  $\theta \leq 7^\circ$  (Figure 6-11B)*Positive with and without overhang: Zones 1, 2, and 3*

$(GC_p) = 0.3$	for $A = 10 \text{ ft}^2$
$(GC_p) = 0.4000 - 0.1000 \log A$	for $10 < A = 100 \text{ ft}^2$
$(GC_p) = 0.2$	for $A > 100 \text{ ft}^2$

*Negative without overhang: Zone 1*

$(GC_p) = -1.0$	for $A = 10 \text{ ft}^2$
$(GC_p) = -1.1000 + 0.1000 \log A$	for $10 < A = 100 \text{ ft}^2$
$(GC_p) = -0.9$	for $A > 100 \text{ ft}^2$

*Negative without overhang: Zone 2*

$(GC_p) = -1.8$	for $A = 10 \text{ ft}^2$
$(GC_p) = -2.5000 + 0.7000 \log A$	for $10 < A = 100 \text{ ft}^2$
$(GC_p) = -1.1$	for $A > 100 \text{ ft}^2$

*Negative without overhang: Zone 3*

$(GC_p) = -2.8$	for $A = 10 \text{ ft}^2$
$(GC_p) = -4.5000 + 1.7000 \log A$	for $10 < A = 100 \text{ ft}^2$
$(GC_p) = -1.1$	for $A > 100 \text{ ft}^2$

*Negative with overhang: Zones 1 and 2*

$(GC_p) = -1.7$	for $A = 10 \text{ ft}^2$
$(GC_p) = -1.8000 + 0.1000 \log A$	for $10 < A = 100 \text{ ft}^2$
$(GC_p) = -3.0307 + 0.7153 \log A$	for $100 < A = 500 \text{ ft}^2$
$(GC_p) = -1.1$	for $A > 500 \text{ ft}^2$

*Negative with overhang: Zone 3*

$(GC_p) = -2.8$	for $A = 10 \text{ ft}^2$
$(GC_p) = -4.8000 + 2.0000 \log A$	for $10 < A = 100 \text{ ft}^2$
$(GC_p) = -0.8$	for $A > 100 \text{ ft}^2$

Note: Zones are shown in the figures referenced in ASCE 7-02.

**Table 2-3** Gable and Hip Roofs with  $h \leq 60$  ft,  $7^\circ < \theta \leq 27^\circ$  (Figure 6-11C)

<i>Positive with and without overhang: Zones 1, 2, and 3</i>	
$(GC_p) = 0.5$	for $A = 10$ ft <sup>2</sup>
$(GC_p) = 0.7000 - 0.2000 \log A$	for $10 < A = 100$ ft <sup>2</sup>
$(GC_p) = 0.3$	for $A > 100$ ft <sup>2</sup>
<i>Negative with and without overhang: Zone 1</i>	
$(GC_p) = -0.9$	for $A = 10$ ft <sup>2</sup>
$(GC_p) = -1.0000 + 0.1000 \log A$	for $10 < A = 100$ ft <sup>2</sup>
$(GC_p) = -0.8$	for $A > 100$ ft <sup>2</sup>
<i>Negative without overhang: Zone 2</i>	
$(GC_p) = -1.7$	for $A = 10$ ft <sup>2</sup>
$(GC_p) = -2.2000 + 0.5000 \log A$	for $10 < A = 100$ ft <sup>2</sup>
$(GC_p) = -1.2$	for $A > 100$ ft <sup>2</sup>
<i>Negative without overhang: Zone 3</i>	
$(GC_p) = -2.6$	for $A = 10$ ft <sup>2</sup>
$(GC_p) = -3.2000 + 0.6000 \log A$	for $10 < A = 100$ ft <sup>2</sup>
$(GC_p) = -2.0$	for $A > 100$ ft <sup>2</sup>
<i>Negative with overhang: Zone 2</i>	
$(GC_p) = -2.2$	for all $A$ ft <sup>2</sup>
<i>Negative with overhang: Zone 3</i>	
$(GC_p) = -3.7$	for $A = 10$ ft <sup>2</sup>
$(GC_p) = -4.9000 + 1.2000 \log A$	for $10 < A = 100$ ft <sup>2</sup>
$(GC_p) = -2.5$	for $A > 100$ ft <sup>2</sup>
Note: Zones are shown in the figures referenced in ASCE 7-02.	

**Table 2-4** Gable Roofs with  $h \leq 60$  ft,  $27^\circ < \theta \leq 45^\circ$  (Figure 6-11D)

<i>Positive with and without overhang: Zones 1, 2, and 3</i>	
$(GC_p) = 0.9$	for $A = 10$ ft <sup>2</sup>
$(GC_p) = 1.0000 - 0.1000 \log A$	for $10 < A = 100$ ft <sup>2</sup>
$(GC_p) = 0.8$	for $A > 100$ ft <sup>2</sup>
<i>Negative with and without overhang: Zone 1</i>	
$(GC_p) = -1.0$	for $A = 10$ ft <sup>2</sup>
$(GC_p) = -1.2000 + 0.2000 \log A$	for $10 < A = 100$ ft <sup>2</sup>
$(GC_p) = -0.8$	for $A > 100$ ft <sup>2</sup>
<i>Negative without overhang: Zones 2 and 3</i>	
$(GC_p) = -1.2$	for $A = 10$ ft <sup>2</sup>
$(GC_p) = -1.4000 + 0.2000 \log A$	for $10 < A = 100$ ft <sup>2</sup>
$(GC_p) = -1.0$	for $A > 100$ ft <sup>2</sup>
<i>Negative with overhang: Zones 2 and 3</i>	
$(GC_p) = -2.0$	for $A = 10$ ft <sup>2</sup>
$(GC_p) = -2.2000 + 0.2000 \log A$	for $10 < A = 100$ ft <sup>2</sup>
$(GC_p) = -1.8$	for $A > 100$ ft <sup>2</sup>
Note: Zones are shown in the figures referenced in ASCE 7-02.	

**Table 2-5** Multispan Gabled Roofs with  $h \leq 60$  ft,  $10^\circ < \theta \leq 30^\circ$  (Figure 6-13)

<i>Positive: Zones 1, 2, and 3</i>	
$(GC_p) = 0.6$	for $A = 10 \text{ ft}^2$
$(GC_p) = 0.8000 - 0.2000 \log A$	for $10 < A = 100 \text{ ft}^2$
$(GC_p) = 0.4$	for $A > 100 \text{ ft}^2$
<i>Negative: Zone 1</i>	
$(GC_p) = -1.6$	for $A = 10 \text{ ft}^2$
$(GC_p) = -1.8000 + 0.2000 \log A$	for $10 < A = 100 \text{ ft}^2$
$(GC_p) = -1.4$	for $A > 100 \text{ ft}^2$
<i>Negative: Zone 2</i>	
$(GC_p) = -2.2$	for $A = 10 \text{ ft}^2$
$(GC_p) = -2.7000 + 0.5000 \log A$	for $10 < A = 100 \text{ ft}^2$
$(GC_p) = -1.7$	for $A > 100 \text{ ft}^2$
<i>Negative: Zone 3</i>	
$(GC_p) = -2.7$	for $A = 10 \text{ ft}^2$
$(GC_p) = -3.7000 + 1.0000 \log A$	for $10 < A = 100 \text{ ft}^2$
$(GC_p) = -1.7$	for $A > 100 \text{ ft}^2$
Note: Zones are shown in the figures referenced in ASCE 7-02.	

**Table 2-6** Multispan Gable Roofs with  $h \leq 60$  ft,  $30^\circ < \theta \leq 45^\circ$  (Figure 6-13)

<i>Positive: Zones 1, 2, and 3</i>	
$(GC_p) = 1.0$	for $A = 10 \text{ ft}^2$
$(GC_p) = 1.2000 - 0.2000 \log A$	for $10 < A = 100 \text{ ft}^2$
$(GC_p) = 0.8$	for $A > 100 \text{ ft}^2$
<i>Negative: Zone 1</i>	
$(GC_p) = -2.0$	for $A = 10 \text{ ft}^2$
$(GC_p) = -2.9000 + 0.9000 \log A$	for $10 < A = 100 \text{ ft}^2$
$(GC_p) = -1.1$	for $A > 100 \text{ ft}^2$
<i>Negative: Zone 2</i>	
$(GC_p) = -2.5$	for $A = 10 \text{ ft}^2$
$(GC_p) = -3.3000 + 0.8000 \log A$	for $10 < A = 100 \text{ ft}^2$
$(GC_p) = -1.7$	for $A > 100 \text{ ft}^2$
<i>Negative: Zone 3</i>	
$(GC_p) = -2.6$	for $A = 10 \text{ ft}^2$
$(GC_p) = -3.5000 + 0.9000 \log A$	for $10 < A = 100 \text{ ft}^2$
$(GC_p) = -1.7$	for $A > 100 \text{ ft}^2$
Note: Zones are shown in the figures referenced in ASCE 7-02.	

**Table 2-7** Monoslope Roofs with  $h \leq 60$  ft,  $3^\circ < \theta \leq 10^\circ$  (Figure 6-14A)

<i>Positive: All Zones</i>	
$(GC_p) = 0.3$	for $A = 10$ ft <sup>2</sup>
$(GC_p) = 0.4000 - 0.1000 \log A$	for $10 < A = 100$ ft <sup>2</sup>
$(GC_p) = 0.2$	for $A > 100$ ft <sup>2</sup>
<i>Negative: Zone 1</i>	
$(GC_p) = -1.1$	for all $A$ ft <sup>2</sup>
<i>Negative: Zone 2</i>	
$(GC_p) = -1.3$	for $A = 10$ ft <sup>2</sup>
$(GC_p) = -1.4000 + 0.1000 \log A$	for $10 < A = 100$ ft <sup>2</sup>
$(GC_p) = -1.2$	for $A > 100$ ft <sup>2</sup>
<i>Negative: Zone 2'</i>	
$(GC_p) = -1.6$	for $A = 10$ ft <sup>2</sup>
$(GC_p) = -1.7000 + 0.1000 \log A$	for $10 < A = 100$ ft <sup>2</sup>
$(GC_p) = -1.5$	for $A > 100$ ft <sup>2</sup>
<i>Negative: Zone 3</i>	
$(GC_p) = -1.8$	for $A = 10$ ft <sup>2</sup>
$(GC_p) = -2.4000 + 0.6000 \log A$	for $10 < A = 100$ ft <sup>2</sup>
$(GC_p) = -1.2$	for $A > 100$ ft <sup>2</sup>
<i>Negative: Zone 3'</i>	
$(GC_p) = -2.6$	for $A = 10$ ft <sup>2</sup>
$(GC_p) = -3.6000 + 1.0000 \log A$	for $10 < A = 100$ ft <sup>2</sup>
$(GC_p) = -1.6$	for $A > 100$ ft <sup>2</sup>
Note: Zones are shown in the figures referenced in ASCE 7-02.	

**Table 2-8** Monoslope Roofs with  $h \leq 60$  ft,  $10^\circ < \theta \leq 30^\circ$  (Figure 6-14B)

<i>Positive: All Zones</i>	
$(GC_p) = 0.4$	for $A = 10$ ft <sup>2</sup>
$(GC_p) = 0.5000 - 0.1000 \log A$	for $10 < A = 100$ ft <sup>2</sup>
$(GC_p) = 0.3$	for $A > 100$ ft <sup>2</sup>
<i>Negative: Zone 1</i>	
$(GC_p) = -1.3$	for $A = 10$ ft <sup>2</sup>
$(GC_p) = -1.5000 + 0.2000 \log A$	for $10 < A = 100$ ft <sup>2</sup>
$(GC_p) = -1.1$	for $A > 100$ ft <sup>2</sup>
<i>Negative: Zone 2</i>	
$(GC_p) = -1.6$	for $A = 10$ ft <sup>2</sup>
$(GC_p) = -2.0000 + 0.4000 \log A$	for $10 < A = 100$ ft <sup>2</sup>
$(GC_p) = -1.2$	for $A > 100$ ft <sup>2</sup>
<i>Negative: Zone 3</i>	
$(GC_p) = -2.9$	for $A = 10$ ft <sup>2</sup>
$(GC_p) = -3.8000 + 0.9000 \log A$	for $10 < A = 100$ ft <sup>2</sup>
$(GC_p) = -2.0$	for $A > 100$ ft <sup>2</sup>
Note: Zones are shown in the figures referenced in ASCE 7-02.	

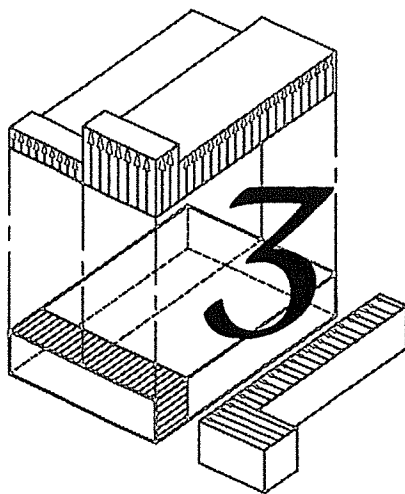
**Table 2-9** Sawtooth Roofs with  $h \leq 60$  ft (Figure 6-15)

<i>Positive: Zone 1</i>	
$(GC_p) = 0.7$	for $A = 10 \text{ ft}^2$
$(GC_p) = 0.8766 - 0.1766 \log A$	for $10 < A = 500 \text{ ft}^2$
$(GC_p) = 0.4$	for $A > 500 \text{ ft}^2$
<i>Positive: Zone 2</i>	
$(GC_p) = 1.1$	for $A = 10 \text{ ft}^2$
$(GC_p) = 1.4000 - 0.3000 \log A$	for $10 < A = 100 \text{ ft}^2$
$(GC_p) = 0.8$	for $A > 100 \text{ ft}^2$
<i>Positive: Zone 3</i>	
$(GC_p) = 0.8$	for $A = 10 \text{ ft}^2$
$(GC_p) = 0.9000 - 0.1000 \log A$	for $10 < A = 100 \text{ ft}^2$
$(GC_p) = 0.7$	for $A > 100 \text{ ft}^2$
<i>Negative: Zone 1</i>	
$(GC_p) = -2.2$	for $A = 10 \text{ ft}^2$
$(GC_p) = -2.8474 + 0.6474 \log A$	for $10 < A = 500 \text{ ft}^2$
$(GC_p) = -1.1$	for $A > 500 \text{ ft}^2$
<i>Negative: Zone 2</i>	
$(GC_p) = -3.2$	for $A = 10 \text{ ft}^2$
$(GC_p) = -4.1418 + 0.9418 \log A$	for $10 < A = 500 \text{ ft}^2$
$(GC_p) = -1.6$	for $A > 500 \text{ ft}^2$
<i>Negative: Zone 3 (span A)</i>	
$(GC_p) = -4.1$	for $A = 10 \text{ ft}^2$
$(GC_p) = -4.5000 + 0.4000 \log A$	for $10 < A = 100 \text{ ft}^2$
$(GC_p) = -8.2782 + 2.2891 \log A$	for $100 < A = 500 \text{ ft}^2$
$(GC_p) = -2.1$	for $A > 500 \text{ ft}^2$
<i>Negative: Zone 3 (spans B, C, D)</i>	
$(GC_p) = -2.6$	for $A = 100 \text{ ft}^2$
$(GC_p) = -4.6030 + 1.0015 \log A$	for $100 < A = 500 \text{ ft}^2$
$(GC_p) = -1.9$	for $A > 500 \text{ ft}^2$

Note: Zones are shown in the figures referenced in ASCE 7-02.

**Table 2-10** Roofs and Walls for Buildings with  $h > 60$  ft (Figure 6-17)

<i>Roofs <math>\theta \leq 10^\circ</math></i>	
<i>Negative: Zone 1</i>	
$(GC_p) = -1.4$	for $A = 10 \text{ ft}^2$
$(GC_p) = -1.6943 + 0.2943 \log A$	for $10 < A = 500 \text{ ft}^2$
$(GC_p) = -0.9$	for $A > 500 \text{ ft}^2$
<i>Negative: Zone 2</i>	
$(GC_p) = -2.3$	for $A = 10 \text{ ft}^2$
$(GC_p) = -2.7120 + 0.4120 \log A$	for $10 < A = 500 \text{ ft}^2$
$(GC_p) = -1.6$	for $A > 500 \text{ ft}^2$
<i>Negative: Zone 3</i>	
$(GC_p) = -3.2$	for $A = 10 \text{ ft}^2$
$(GC_p) = -3.7297 + 0.5297 \log A$	for $10 < A = 500 \text{ ft}^2$
$(GC_p) = -2.3$	for $A > 500 \text{ ft}^2$
<i>Walls all <math>\theta</math></i>	
<i>Positive: Zones 4 and 5</i>	
$(GC_p) = 0.9$	for $A = 20 \text{ ft}^2$
$(GC_p) = 1.1792 - 0.2146 \log A$	for $20 < A = 500 \text{ ft}^2$
$(GC_p) = 0.6$	for $A > 500 \text{ ft}^2$
<i>Negative: Zone 4</i>	
$(GC_p) = -0.9$	for $A = 20 \text{ ft}^2$
$(GC_p) = -1.0861 + 0.1431 \log A$	for $20 < A = 500 \text{ ft}^2$
$(GC_p) = -0.7$	for $A > 500 \text{ ft}^2$
<i>Negative: Zone 5</i>	
$(GC_p) = -1.8$	for $A = 20 \text{ ft}^2$
$(GC_p) = -2.5445 + 0.5723 \log A$	for $20 < A = 500 \text{ ft}^2$
$(GC_p) = -1.0$	for $A > 500 \text{ ft}^2$
<b>Note:</b> Zones are shown in the figures referenced in ASCE 7-02.	



# 3 Examples

In this chapter, twelve examples illustrate how wind loads are determined using the simplified and analytical procedures described in ASCE 7-02. These examples provide guidance to the user of the Standard in determining wind loads for several types of buildings:

<i>Example no.</i>	<i>Building/methodology</i>	<i>Section no.</i>	<i>Figure no. (this Guide)</i>
1	30-ft × 60-ft × 15-ft commercial building with concrete masonry unit (CMU) walls	3.1	3-1
2	Commercial building from Ex. 1 using simplified procedure	3.2	3-1
3	100-ft × 200-ft × 160-ft-high office building located in hurricane zone	3.3	3-6
4	Office building from Ex. 3 located on an escarpment	3.4	3-10
5	A typical 2,500-ft <sup>2</sup> house with gable/hip roof	3.5	3-11(a)–(d)
6	200-ft × 250-ft gable roof commercial/warehouse building using all height provisions	3.6	3-13
7	Commercial/warehouse building from Ex. 6 using low-rise building provisions	3.7	3-13
8	40-ft × 80-ft commercial building with monoslope roof with overhang	3.8	3-27
9	U-shaped apartment building	3.9	3-33
10	50-ft × 20-ft billboard sign on poles (flexible) 60 ft above ground	3.10	3-38
11	Domed roof building	3.11	3-40
12	Unusually shaped building	3.12	3-43

These examples represent a variety of situations in determination of wind loads. The equation, table, figure, and section numbers of ASCE 7-02

are cited where appropriate. Every effort has been made to check the accuracy of the numbers in calculations, although no absolute assurance is given.

### 3.1 Example 1 30-ft × 60-ft × 15-ft Commercial Building with Concrete Masonry Unit Walls

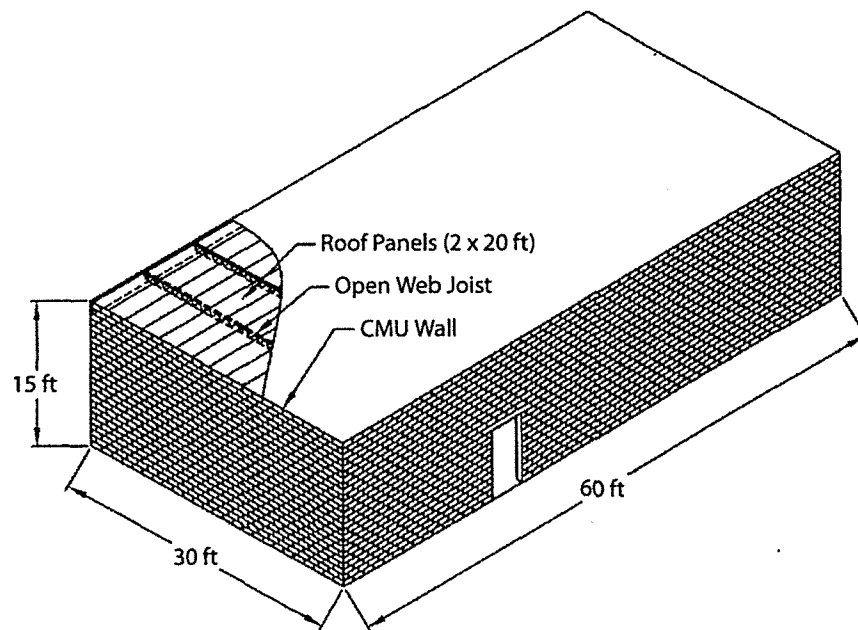
In this example, design wind pressures for a typical load-bearing one-story masonry building are determined. The building is shown in Figure 3-1, and data is as follows:

---

<i>Location:</i>	Corpus Christi, Texas
<i>Topography:</i>	Homogeneous
<i>Terrain:</i>	Flat, open terrain
<i>Dimensions:</i>	30 ft × 60 ft × 15 ft, flat roof
<i>Framing:</i>	CMU walls on three sides Steel framing in front with glass Open web joists, 30-ft span spaced at 5 ft on center, covered with metal panel to provide roof diaphragm action
<i>Cladding:</i>	Roof metal panels are 2-ft wide, 20-ft long Doors and glass size vary; glass is debris resistant

---

This example uses Method 2, Analytical Procedure, of Section 6.3 of ASCE 7-02 for rigid buildings of all heights. The same building is illustrated in Ex. 2 (Section 3.2) using Method 1, Simplified Procedure, of Section 6.4 of ASCE 7-02.



**Figure 3-1** Building Dimensions for Examples 1 and 2

**Basic Wind Speed** Selection of the basic wind speed is addressed in Section 6.5.4 of the Standard. Basic wind speed for Corpus Christi, Texas, is 130 mph (Figure 6-1a of the Standard).

**Exposure** The building is located on flat and open terrain. It does not fit Exposures B or D, therefore use Exposure C (Sections 6.5.6.2 and 6.5.6.3 of the Standard).

**Building Classification** The building function is shops. It is not considered an essential facility. Building Category II is appropriate; see Table 1-1 of the Standard.

**Velocity Pressure** The velocity pressures are computed using

$$q_z = 0.00256 K_z K_{zt} K_d V^2 I \quad (\text{Eq. 6-15})$$

where

$K_z$  = 0.85 from Table 6-3 of the Standard for Case 1 (C&C) and Case 2 (MWFRS); for 0 to 15 ft, there is only one value:  $K_z = k_h$

$K_{zt}$  = 1.0 for homogeneous topography (see Section 6.5.7 of the Standard)

$K_d$  = 0.85 for buildings (see Table 6-4 of the Standard)

$V$  = 130 mph (see Figure 6-1a of the Standard)

$I$  = 1.0 for Category II building (see Table 6-1 of the Standard)

$$\begin{aligned} q_z &= 0.00256 (0.85) (1.0) (0.85) (130)^2 (1.0) \\ &= 31.3 \text{ psf} \end{aligned}$$

$$q_h = 31.3 \text{ psf for } h = 15 \text{ ft}$$

**Gust Effect Factor** The building is considered a rigid structure. Section 6.5.8.1 of the Standard permits use of  $G = 0.85$ .

If the detailed procedure for a rigid structure is used (Section 6.5.8.1 of the Standard), the calculated value of  $G = 0.89$ ; however, the Standard permits the use of the value of  $G = 0.85$ . Detailed calculations for  $G$  value are illustrated in Ex. 3 (Section 3.3 of this guide).

Use  $G = 0.85$  for this example.

**Internal Pressure Coefficient** The building is located in a hurricane-prone area (see definition of wind-borne debris region in Section 6.2 of the Standard). Section 6.5.9.3 requires that glazing be considered openings unless it is protected or debris resistant.

The example building has debris-resistant glazing, and other openings are such that it does not qualify for partially enclosed or open buildings.

Use  $(GC_{pi}) = +0.18$  and  $-0.18$  for enclosed buildings (see Figure 6-5 of the Standard).

**Design Wind Pressures for MWFRS**

Design wind pressures are determined using the equation

$$p = qGC_p - q_i (GC_{pi}) \quad (\text{Eq. 6-17})$$

where

$$\begin{aligned}q &= q_z \text{ for windward wall (31.3 psf for this example)} \\q &= q_h \text{ for leeward wall, side walls, and roof (31.3 psf for this example)} \\G &= 0.85 \\C_p &= \text{Values of external pressure coefficients} \\q_i &= q_h \text{ for enclosed building (31.3 psf)} \\(GC_{pi}) &= +0.18 \text{ and } -0.18\end{aligned}$$

The values of external pressure coefficients are obtained from Figure 6-6 of the Standard.

### Wall $C_p$

The windward wall pressure coefficient is 0.8.

The side wall pressure coefficient is  $-0.7$ .

The leeward wall pressure coefficients are a function of  $L/B$  ratio:

For  $L/B = 0.5$ ,  $C_p = -0.5$  for wind normal to 60 ft

For  $L/B = 2.0$ ,  $C_p = -0.3$  for wind normal to 30 ft

### Roof $C_p$

The roof pressure coefficients are a function of roof slope and  $h/L$ . For  $\theta < 10^\circ$  and  $h/L = 0.25$  and  $0.5$ :

First value:

$$\begin{aligned}C_p &= -0.9 \text{ for distance } 0 \text{ to } h \\C_p &= -0.5 \text{ for distance } h \text{ to } 2h \\C_p &= -0.3 \text{ for distance } > 2h\end{aligned}$$

Second value:

$C_p = -0.18$  for distance 0 to end. This value of smaller uplift pressures on the roof can become critical when wind load is combined with roof live load or snow load; load combinations are given in Section 2.3 and 2.4 of the Standard. For brevity, loading for this value is not shown in this example.

### MWFRS Pressures

Windward wall:

$$\begin{aligned}p &= 31.3 (0.85) (0.8) - 31.3 (\pm 0.18) \\&= 21.3 \pm 5.6 \text{ psf}\end{aligned}$$

Leeward wall:

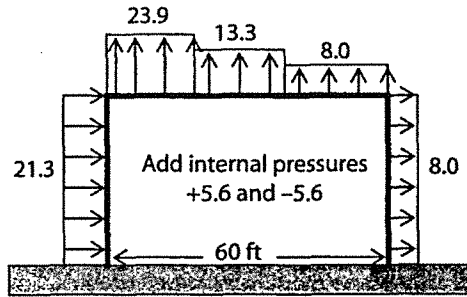
$$\begin{aligned}p &= 31.3 (0.85) (-0.5) - 31.3 (\pm 0.18) \\&= -13.3 \pm 5.6 \text{ psf for wind normal to 60 ft}\end{aligned}$$

Leeward wall:

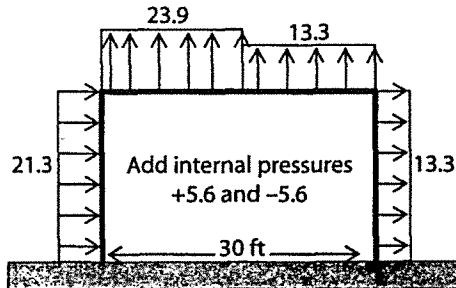
$$\begin{aligned}p &= 31.3 (0.85) (-0.3) - 31.3 (\pm 0.18) \\&= -8.0 \pm 5.6 \text{ psf for wind normal to 30 ft}\end{aligned}$$

Roof – First value:

$$\begin{aligned}p &= 31.3 (0.85) (-0.9) - 31.3 (\pm 0.18) \\&= -23.9 \pm 5.6 \text{ psf for } 0 \text{ to } 15 \text{ ft} \\&= -13.3 \pm 5.6 \text{ psf for } 15 \text{ to } 30 \text{ ft} \\&= -8.0 \pm 5.6 \text{ psf for } > 30 \text{ ft}\end{aligned}$$



**Figure 3-2** Design Pressures for MWFRS when Wind is Normal to 30-ft Wall



**Figure 3-3** Design Pressures for MWFRS when Wind is Normal to 60-ft Wall

The MWFRS design pressures for two directions are shown in Figures 3-2 and 3-3. The internal pressures shown are to be added to the external pressures as appropriate. The internal pressures of the same sign act on all surfaces; thus, they cancel out for total horizontal shear.

### Design Wind Load Cases

According to Section 6.5.12.3 of the Standard, this building shall be designed for the wind Load Cases 1 and 3 as defined in Figure 6-9.

Load Case 1 has been considered above. Figure 3-4 is for Load Case 3.

### Design Pressures for C&C

Design wind pressures are determined using the equation

$$p = q_h [(GC_p) - (GC_{pi})] \quad (\text{Eq. 6-22})$$

where

$$q_h = 31.3 \text{ psf}$$

$(GC_p)$  = Values obtained from Figure 6-11 of the Standard; they are a function of effective area and zone

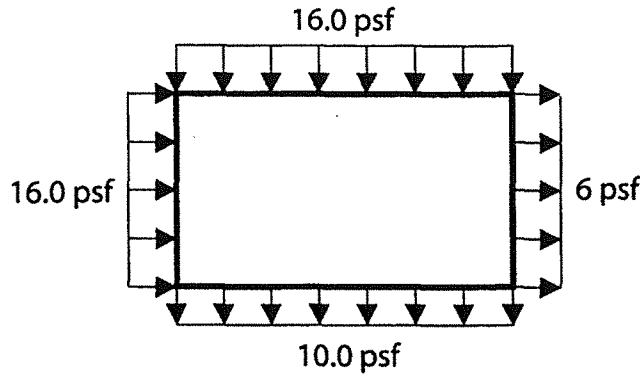
$$(GC_{pi}) = +0.18 \text{ and } -0.18$$

### Wall Pressures

CMU walls are supported at the roof diaphragm and at ground, span = 15 ft.

CMU wall effective wind area is determined using the definition from Section 6.2 of the Standard: "the width of effective area need not be less than one-third of the span."

$$\text{CMU wall effective wind area, } A = 15 (15/3) = 75 \text{ ft}^2$$



**Figure 3-4** Load Case 3

In Figure 6-11A of the Standard, Note 5 suggests that the pressure coefficient values for walls can be reduced by 10% for roof slope of 10° or less. The values of  $(GC_p)$  are obtained from the figure or from equations of the graphs (see Section 2.4 of this guide).

Corner Zone 5 distance:

smaller of

$$a = 0.1 (30) = 3 \text{ ft (controls)}$$

or

$$a = 0.4 (15) = 6 \text{ ft}$$

Corner Zone 5:

$$p = 31.3 [(-1.09) (0.9) - (\pm 0.18)] = -36.3 \text{ psf}$$

$$p = 31.3 [(0.85) (0.9) - (\pm 0.18)] = +29.6 \text{ psf}$$

Interior Zone 4:

$$p = 31.3 [(-0.95) (0.9) - (\pm 0.18)] = -32.4 \text{ psf}$$

$$p = 31.3 [(0.85) (0.9) - (\pm 0.18)] = +29.6 \text{ psf}$$

Note: The CMU walls have uplift pressure from the roof, which is determined on the basis of MWFRS.

Pressure for glazing and mullions can be determined similarly with the known effective wind area.

### Roof Joist Pressures

Roof joists span 30 ft and are spaced 5 ft apart. The joist can be in Zone 1 (interior of roof) or Zone 2 (eave area). Zone 3 (roof corner area) acts only on a part of the joist.

Width of Zones 2 and 3: (Figure 6-11B)

smaller of

$$a = 0.1 (30) = 3 \text{ ft (controls)}$$

or

$$a = 0.4 (15) = 6 \text{ ft}$$

Joist Effective Wind Area:

larger of

$$A = 30 \times 5 = 150 \text{ ft}$$

or

$$A = 30 \times (30/3) = 300 \text{ ft (controls)}$$

The values of  $(GC_p)$  are obtained from Figure 6-11B of the Standard or from equations of the graphs using effective area  $A = 300 \text{ ft}^2$ .

Interior Zone 1:

$$p = 31.3 [-0.9 \pm 0.18] = -33.8 \text{ psf}$$

$$p = 31.3 [+0.2 \pm 0.18] = +11.9 \text{ psf}$$

Eave Zone 2 and Corner Zone 3:

$$p = 31.3 [-1.1 \pm 0.18] = -40.1 \text{ psf}$$

$$p = 31.3 [+0.2 \pm 0.18] = +11.9 \text{ psf}$$

### Roof Panel Pressures

Even though roof panel length is 20 ft, each panel spans 5 ft between joists.

Roof Panel Effective Area:

larger of

$$A = 5 \times 2 = 10 \text{ ft}^2 \text{ (controls)}$$

or

$$A = 5 \times (5/3) = 8 \text{ ft}^2$$

(width of Zones 2 and 3,  $a = 3 \text{ ft}$ )

Interior Zone 1:

$$p = 31.3 [-1.0 \pm 0.18] = -36.9 \text{ psf}$$

$$p = 31.3 [+0.3 \pm 0.18] = +15.0 \text{ psf}$$

Eave Zone 2:

$$p = 31.3 [-1.8 \pm 0.18] = -62.0 \text{ psf}$$

$$p = 31.3 [+0.3 \pm 0.18] = +15.0 \text{ psf}$$

Corner Zone 3:

$$p = 31.3 [-2.8 \pm 0.18] = -93.3 \text{ psf}$$

$$p = 31.3 [+0.3 \pm 0.18] = +15.0 \text{ psf}$$

Notes:

- Internal pressure coefficient of +0.18 or -0.18 is used to give critical pressures.
- The roof panel fasteners design pressures will be the same as metal panel since values of  $(GC_p)$  are the same for wind effective areas less than  $10 \text{ ft}^2$ .

### 3.2 Example 2 Ex. 1 Using Simplified Procedure

In this example, design wind pressures for the building of Ex. 1 are determined using the simplified procedure of Section 6.4 of the Standard. Data for the building are the same as Ex. 1 (see Section 3.1 and Figure 3-1).

In order to use the simplified procedure, all conditions of Section 6.4.1 of the Standard must be satisfied:

1. It is a simple diaphragm building.
2. Its mean roof height  $h$  is less than 60 ft and does not exceed the least horizontal dimension.
3. Since the building has debris-resistant glazing and no dominant opening in any one wall, it can be classified as an enclosed building. It also conforms to the wind-borne debris provisions of Section 6.5.9.3 of the Standard.
4. It has a regular shape.
5. It is a rigid building ( $h/\text{width} \ll 4$ ) (see Commentary in the Standard).
6. There is no expansion joint.
7. There is no abrupt change in topography (see Section 6.5.7.1 of the Standard for requirements of topographic effects).
8. It has an approximately symmetrical cross section in each direction with a flat roof.

Wind pressures for both the MWFRS and C&C can be obtained using the simplified procedure.

#### Basic Wind Speed

Basic wind speed for Corpus Christi, Texas, is 130 mph (see Figure 6-1a of the Standard).

#### Building Classification

Building Category II is appropriate. Importance Factor  $I = 1.00$  (see Table 6-1 of the Standard).

#### Exposure

The building is located on flat and open terrain. It does not fit Exposures B or D; therefore, use Exposure C (Sections 6.5.6.2 and 6.5.6.3 of the Standard). Note that wind pressure values given in Figures 6-2 and 6-3 of the Standard are for Exposure B.

#### Height and Exposure Adjustment Coefficient $\lambda$

From Figure 6-2 of the Standard,  $\lambda = 1.21$ .

#### Design Wind Pressures for MWFRS (See Table 3-1)

This building has a flat roof, so only Load Case 1 is checked.

$$\begin{aligned} p_s &= \lambda I p_{s30} \\ &= 1.21 \times 1.0 \times p_{s30} \end{aligned} \quad (\text{Eq. 6-1})$$

In the simplified procedure, design roof pressure includes internal pressure. The wall pressure is the combined windward and leeward wall pressures (internal pressure cancels).

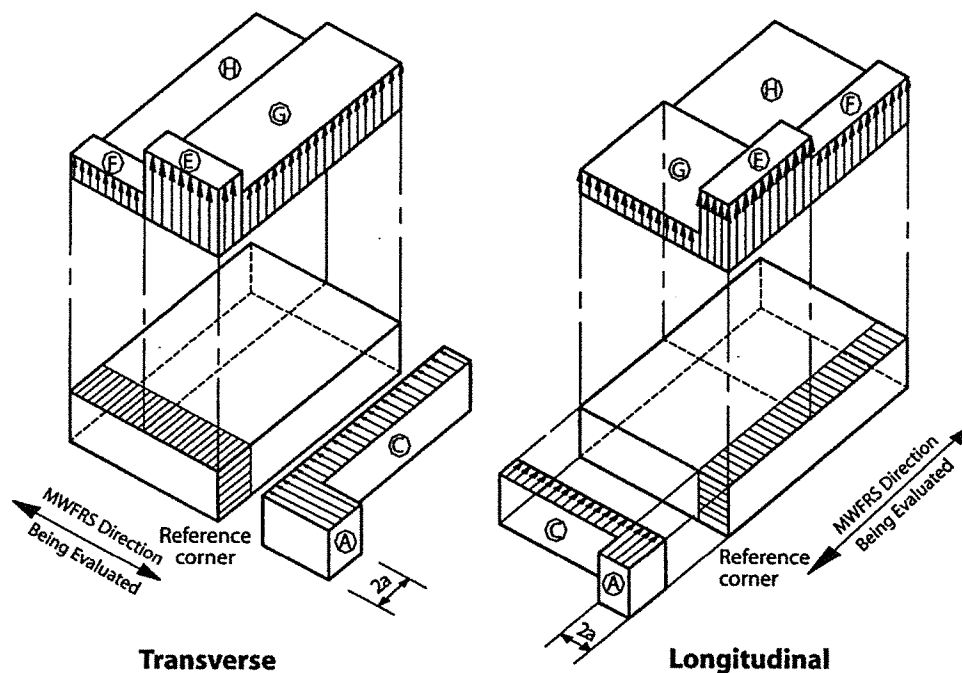
**Table 3-1** Design Wind Pressures

Zones	A	C	E	F	G	H
$p_s$ (psf)	32.4	21.5	-39.0	-22.1	-27.1	-17.2

Notes:

(1) Zones are defined in Figure 6-2 of the Standard:  $a$  = smaller of  $0.1 \times 30 = 3$  ft (control) or  $0.4 \times 15 = 6$  ft.

(2) The load patterns shown in Figure 3-5 shall be applied to each corner of the building in turn as the reference corner.



**Figure 3-5** Design Wind Pressure

**Design Pressures for C&C**

According to Section 6.4.2.2 of the Standard:

$$\begin{aligned}
 p_{net} &= \lambda I p_{net30} \\
 &= 1.21 \times 1.0 \times p_{net30}
 \end{aligned}
 \tag{Eq. 6-2}$$

**Wall Pressures**

The effective wind area for a CMU wall is  $75 \text{ ft}^2$  (see Ex. 1). Linear interpolation is permitted in Figure 6-3 of the Standard.

Zone 4:

$$\begin{aligned}
 p_{net} &= 1.21 \times 1.0 \times 26.6 = 32.2 \text{ psf} \\
 p_{net} &= 1.21 \times 1.0 \times (-29.1) = -35.2 \text{ psf}
 \end{aligned}$$

Zone 5:

$$\begin{aligned}
 p_{net} &= 1.21 \times 1.0 \times 26.6 = 32.2 \text{ psf} \\
 p_{net} &= 1.21 \times 1.0 \times (-33.0) = -39.9 \text{ psf}
 \end{aligned}$$

### Roof Joist Pressures

From Figure 6-3 of the Standard, for  $V = 130$  mph, for effective wind area of  $300 \text{ ft}^2$ , the design pressures are:

Zone 1:

$$p_{net} = 1.21 \times 1.0 \times 9.8 = 11.9 \text{ psf}$$

$$p_{net} = 1.21 \times 1.0 \times (-27.8) = -33.6 \text{ psf}$$

Zones 2 and 3:

$$p_{net} = 1.21 \times 1.0 \times 9.8 = 11.9 \text{ psf}$$

$$p_{net} = 1.21 \times 1.0 \times (-33.0) = -39.9 \text{ psf}$$

### Roof Panel Pressures

Effective wind area for roof panel is  $10 \text{ ft}^2$  (see Ex. 1).

From Figure 6-3 of the Standard, for  $V = 130$  mph, for effective wind area of  $10 \text{ ft}^2$ , the design pressures are:

Zone 1:

$$p_{net} = 1.21 \times 1.0 \times 12.4 = 15.0 \text{ psf}$$

$$p_{net} = 1.21 \times 1.0 \times (-30.4) = -36.8 \text{ psf}$$

Zone 2:

$$p_{net} = 1.21 \times 1.0 \times 12.4 = 15.0 \text{ psf}$$

$$p_{net} = 1.21 \times 1.0 \times (-51.0) = -61.7 \text{ psf}$$

Zone 3:

$$p_{net} = 1.21 \times 1.0 \times 12.4 = 15.0 \text{ psf}$$

$$p_{net} = 1.21 \times 1.0 \times (-76.8) = -92.9 \text{ psf}$$

The analytical procedure in Ex. 1 yields C&C design pressures close to the results of the simplified procedure.

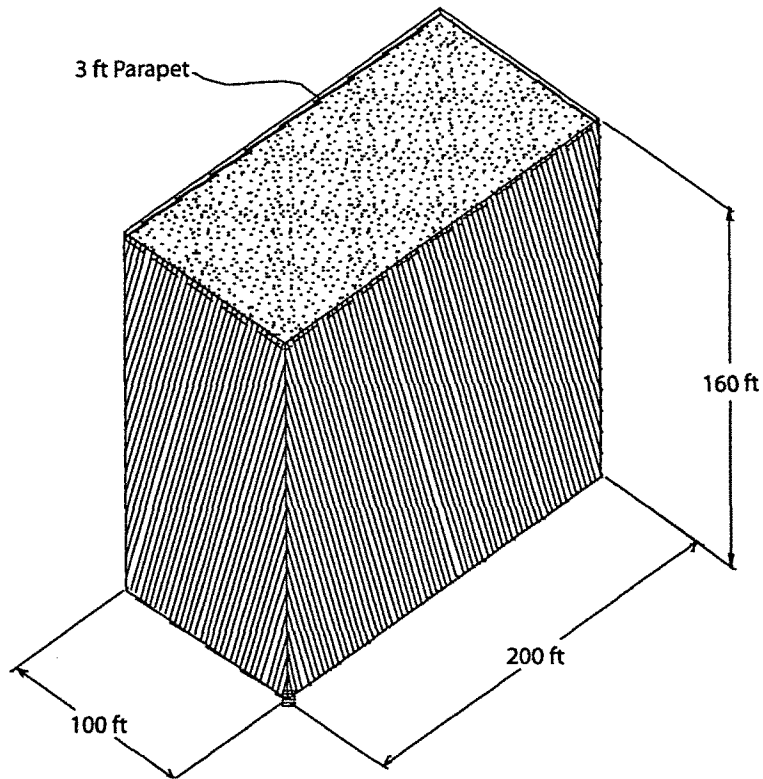
## 3.3 Example 3 100-ft × 200-ft × 160-ft-High Office Building

This building is illustrated in Figure 3-6; data for the building is as follows:

---

<i>Location:</i>	Near Houston, Texas
<i>Topography:</i>	Homogeneous
<i>Terrain:</i>	Suburban
<i>Dimensions:</i>	100 ft × 200 ft in plan Roof height of 157 ft with 3-ft parapet Flat roof
<i>Framing:</i>	Reinforced concrete rigid frame in both directions Floor and roof slabs provide diaphragm action Fundamental natural frequency is greater than 1 Hz (Since the height to least horizontal dimension is less than 4, the fundamental frequency is judged to be greater than 1 Hz.)
<i>Cladding:</i>	Mullions for glazing panels span 11 ft between floor slabs Mullion spacing is 5 ft

---



**Figure 3-6** 100-ft × 200-ft × 160-ft Building

Glazing panels are 5-ft wide × 5-ft 6 in. high (typical); they are not resistant to wind-borne debris impact. Also, there are buildings up to 60 ft in height located within 1,500-ft radius.

The analytical procedure of ASCE 7-02 is to be used.

**Exposure**

The building is located in a suburban area; according to Section 6.5.6.3 of the Standard, Exposure B is used.

**Building Classification**

The building function is office space. It is not considered an essential facility or likely to be occupied by 300 persons in a single area at one time. Therefore, building Category II is appropriate (see Table 1-1 of the Standard).

**Basic Wind Speed**

Selection of the basic wind speed is addressed in Section 6.5.4 of the Standard. Vicinity of Houston, Texas, is located on the 120-mph contour. The basic wind speed  $V = 120$  mph (see Figure 6-1a of the Standard).

**Velocity Pressures**

The velocity pressures are computed using the following equation:

$$q_z = 0.00256 K_z K_{zt} K_d V^2 I \text{ psf} \quad (\text{Eq. 6-15})$$

where

$K_z$  = value obtained from Table 6-3, Case 1 for C&C and Case 2 for MWFRS

$K_{zt}$  = 1.0 for homogeneous topography

**Table 3-2**  $q_z$  Velocity Pressures

Height (ft)	MWFRS		C&C	
	$K_z$	$q_z$ (psf)	$K_z$	$q_z$ (psf)
0-15	0.57	17.9	0.70	21.9
30	0.70	21.9	0.70	21.9
50	0.81	25.4	0.81	25.4
80	0.93	29.1	0.93	29.1
120	1.04	32.6	1.04	32.6
Roof = 157	1.12	35.1	1.12	35.1
Parapet = 160	1.13	35.4	1.13	35.4

Note:  $q_h = 35.1$  psf.

$K_d = 0.85$  for buildings (see Table 6-4 of the Standard)

$V = 120$  mph

$I = 1.0$  for Category II classification (see Table 6-1 of the Standard)

$$q_z = 0.00256 K_z (1.0) (0.85) (120)^2 (1.0)$$

$$= 31.3 K_z \text{ psf}$$

Values for  $K_z$  and the resulting velocity pressures are given in Table 3-2. The velocity pressure at mean roof height,  $q_h$ , is 35.1 psf.

**Design Wind Pressures for the MWFRS**

The design pressures for this building are obtained by equation:

$$p = qGC_p - q_i(GC_{pi}) \quad (\text{Eq. 6-17})$$

where

$q = q_z$  for windward wall at height  $z$  above ground

$q = q_h$  for leeward wall, side walls, and roof

$q_i = q_h$  for windward walls, side walls, leeward walls, and roofs for negative internal pressure evaluation in partially enclosed building

$q_i = q_z$  for positive internal pressure evaluation in partially enclosed buildings where height  $z$  is defined as the level of the highest opening in the building that could affect the positive internal pressure

$G =$  Gust effect factor for rigid building and structure

$C_p =$  External pressure coefficient

$(GC_{pi}) =$  Internal pressure coefficient

**Gust Effect Factor, G**

Dimensions of this building where  $h/\text{least width} = 1.6 < 4.0$  indicates that it is a rigid structure:

$$G = 0.925 \left\{ \frac{(1 + 1.7 gQ I_z Q)}{(1 + 1.7 gV I_z)} \right\} \quad (\text{Eq. 6-4})$$

$$gQ = g_v = 3.4 \quad (\text{Sec. 6.5.8.1})$$

$$\bar{z} = 0.6(157) = 94.2 \text{ ft (controls)} \quad (\text{Sec. 6.5.8.1})$$

$$\bar{z} = z_{min} = 30 \text{ ft} \quad (\text{Table 6-2})$$

$$c = 0.30 \quad (\text{Table 6-2})$$

$$I_{\bar{z}} = c \left( \frac{33}{\bar{z}} \right)^{1/6} = 0.30 \left( \frac{33}{94.2} \right)^{1/6} = 0.25 \quad (\text{Eq. 6-5})$$

$$L_{\bar{z}} = l \left( \frac{\bar{z}}{33} \right)^{1/3} = 320 \left( \frac{94.2}{33} \right)^{1/3} = 454 \text{ ft} \quad (\text{Eq. 6-7})$$

$$Q = \frac{1}{\sqrt{1 + 0.63 \left( \frac{B+h}{L_{\bar{z}}} \right)^{0.63}}} \quad (\text{Eq. 6-6})$$

$B = 100 \text{ ft}$  (smaller value gives larger  $Q$ )

$$Q = \frac{1}{\sqrt{1 + 0.63 \left( \frac{100+157}{454} \right)^{0.63}}} = 0.83$$

$$G = 0.925 \left\{ \frac{(1 + 1.7 \times 3.4 \times 0.25 \times 0.83)}{(1 + 1.7 \times 3.4 \times 0.25)} \right\} = 0.83$$

**Wall External Pressure Coefficients,  $C_p$**   
(see Table 3-3)

The values for the external pressure coefficients for the various wall surfaces are obtained from Figure 6-6 of the Standard. The windward wall pressure coefficient is 0.8. The side wall pressure coefficient is  $-0.7$ .

The leeward wall pressure coefficient is a function of the  $L/B$  ratio. For wind normal to the 200-ft face,  $L/B = 100/200 = 0.5$ ; therefore, the leeward wall pressure coefficient is  $-0.5$ . For wind normal to 100-ft face,  $L/B = 200/100 = 2.0$ ; therefore, the leeward wall pressure coefficient is  $-0.3$ .

**Roof  $C_p$  (with the Wind Normal to the 200-ft Face)** (Table 3-4)

For  $h/L = 157/100 \approx 1.6 > 1.0$ , and  $\theta < 10^\circ$ , two zones are specified in Figure 6-6 of the Standard:

First value:

$$0 \text{ to } h/2, C_p = -1.3$$

$$> h/2, C_p = -0.7$$

**Table 3-3** Wall  $C_p$  for Ex. 3

Surface	Wind direction	$L/B$	$C_p$
Windward wall	All	All	0.80
Leeward wall	$\perp$ to 200-ft face	0.5	$-0.50$
	$\parallel$ to 200-ft face	2.0	$-0.30$
Side wall	All	All	$-0.70$

**Table 3-4** Roof  $C_p$  for Wind Normal to 200-ft Face

Distance from leading edge	$C_p$
0 to $h/2$	-1.04
$> h/2$	-0.70

Note:  $h = 157$  ft.

**Table 3-5** Roof  $C_p$  for Wind Normal to 100-ft Face

Distance from windward edge	$h/L \leq 0.5$	$h/L = 0.8$	$h/L \geq 1.0$
0 to $h/2$	-0.9	-0.98	-1.04
$h/2$ to $h$	-0.9	-0.78	-0.7
$h$ to $2h$	-0.5	-0.62	-0.7

Second value:

$C_p = -0.18$ . This value of smaller uplift pressures on the roof can become critical when wind load is combined with roof live load or snow load; load combinations are given in Section 2.3 and 2.4 of the Standard. For brevity, loading for this value is not shown in this example.

The  $C_p = -1.3$  may be reduced with the area over which it is applicable.

$$\text{Area} = 200 \times 79 = 15,800 \text{ ft}^2$$

Reduction factor = 0.8

$$\text{Reduced } C_p = 0.8 \times (-1.3) = -1.04$$

Roof  $C_p$  (with the Wind Normal to 100-ft Face)  
(Table 3-5)

For  $h/L = 157/200 \approx 0.8$ , interpolation in Figure 6-6 of the Standard is required.

Roof Calculation for 0 to 79 ft ( $h/2$ ) from Edge  
(Wind Normal to 200-ft Face)

$$\text{External pressure} = 35.1(0.83)(-1.04) = -30.3$$

Roof Calculation for 79 ( $h/2$ ) to 100-ft from Edge  
(Wind Normal to 200-ft Face)

$$\text{External pressure} = 35.1(0.83)(-0.70) = -20.4$$

External pressures are summarized in Tables 3-6 and 3-7.

Internal Pressure Coefficients, ( $GC_{pi}$ )

The building is in a hurricane-prone region. Since the glazing is assumed not to be debris resistant, glazing is considered as opening. The building is classified as partially enclosed building.

MWFRS Pressures

$$p = qGC_p - q_i(GC_{pi}) \quad (\text{Eq. 6-17})$$

For partially enclosed buildings:

**Table 3-6** External Pressures for MWFRS: Wind Normal to 200-ft Face

Surface	<i>z</i> (ft)	<i>q</i> (psf)	<i>C<sub>p</sub></i>	External pressures (psf)
Windward wall	0-15	17.9	0.80	11.9
	30	21.9	0.80	14.5
	50	25.4	0.80	16.9
	80	29.1	0.80	19.3
	120	32.6	0.80	21.7
	157	35.1	0.80	23.3
Leeward wall	All	35.1	-0.50	-14.6
Side walls	All	35.1	-0.70	-20.4
Roof	0-79	35.1	-1.04	-30.3
	79-100	35.1	-0.70	-20.4

Note:  $q_h = 35.1$  psf;  $G = 0.83$ .

**Table 3-7** External Pressures for MWFRS: Wind Normal to 100-ft Face

Surface	<i>z</i> (ft)	<i>q</i> (psf)	<i>C<sub>p</sub></i>	External pressure (psf)
Windward wall	0-15	17.9	0.80	11.9
	30	21.9	0.80	14.5
	50	25.4	0.80	16.9
	80	29.1	0.80	19.3
	120	32.6	0.80	21.7
	157	35.1	0.80	23.3
Leeward wall	All	35.1	-0.30	-8.7
Side walls	All	35.1	-0.70	-20.4
Roof	0-79	35.1	-0.98	-28.6
	79-157	35.1	-0.78	-22.7
	157-200	35.1	-0.62	-18.1

Note:  $q_h = 35.1$  psf;  $G = 0.83$ .

$$GC_{pi} = \pm 0.55 \quad (\text{Table 6-7})$$

For  $q_i$ ,  $q_h = 35.1$  psf for negative internal pressure, and  $q_z$  will be evaluated at 90 ft for positive internal pressure (30 ft above height of surrounding buildings in 1,500-ft radius; see Section 6.5.9.3 of the Standard).

### Internal Pressure Calculation

Negative internal pressure =  $35.1 \times (-0.55) = -19.3$  psf

Positive internal pressure =  $30.0 \times 0.55 = 16.5$  psf ( $q_z$  is gained by interpolation at height  $z = 90$  ft)

**Parapet Load on MWFRS** According to Section 6.5.12.2.4 of the Standard:

$$P_p = q_p GC_{pn} \quad (\text{Eq. 6-20})$$

$$q_p = 35.4 \text{ psf}$$

$$GC_{pn} = 1.8 \text{ for windward parapet} \\ = -1.1 \text{ for leeward parapet}$$

Parapet is 3 ft high; the force on parapets of MWFRS can be determined as follows:

$$F = 35.4 \times 1.8 \times 3 = 191.2 \text{ plf for windward parapet} \\ = 35.4 \times (-1.1) \times 3 = -116.8 \text{ plf for leeward parapet}$$

This force is to be applied on the windward parapet and to the leeward parapet.

Design wind pressures for MWFRS are shown in Figure 3-7 for wind normal to 200-ft face and in Figure 3-8 for wind normal to 100-ft face.

For design of parapet, see the loads on components and cladding.

### Design Wind Load Cases

Section 6.5.12.3 of the Standard requires that any building whose wind loads have been determined under the provisions of Sections 6.5.12.2.1 and 6.5.12.2.3 shall be designed for wind load cases as defined in Figure 6-9. Case 1 includes the loadings determined in this example and shown in Figures 3-7 and 3-8. A combination of windward ( $P_W$ ) and leeward ( $P_L$ ) loads are applied for Load Cases 2, 3, and 4 as shown in Figure 3-9.

### Design Pressures for C&C

Design pressure for C&C is obtained by the following equation:

$$p = q(GC_p) - q_i(GC_{pi}) \quad (\text{Eq. 6-23})$$

where

$$q = q_z \text{ for windward wall calculated at height } z \text{ and } q_h \text{ for leeward wall, side walls, and roof calculated at height } h$$

$$q_i = q_h = 35.1 \text{ psf for negative internal pressure} \\ = q_z \text{ evaluated at } 90 \text{ ft} = 30.0 \text{ psf for positive internal pressure}$$

$$(GC_p) = \text{External pressure coefficient (see Figure 6-17 of the Standard)}$$

$$(GC_{pi}) = \text{Internal pressure coefficient (see Figure 6-5 of the Standard)}$$

### Wall Design Pressures (Table 3-8)

The pressure coefficients ( $GC_p$ ) are a function of effective wind area. The definition of effective wind area for a C&C panel is the span length multiplied by an effective width that need not be less than one-third the span length (see Section 6.2 of the Standard). The effective wind areas,  $A$ , for wall components are:

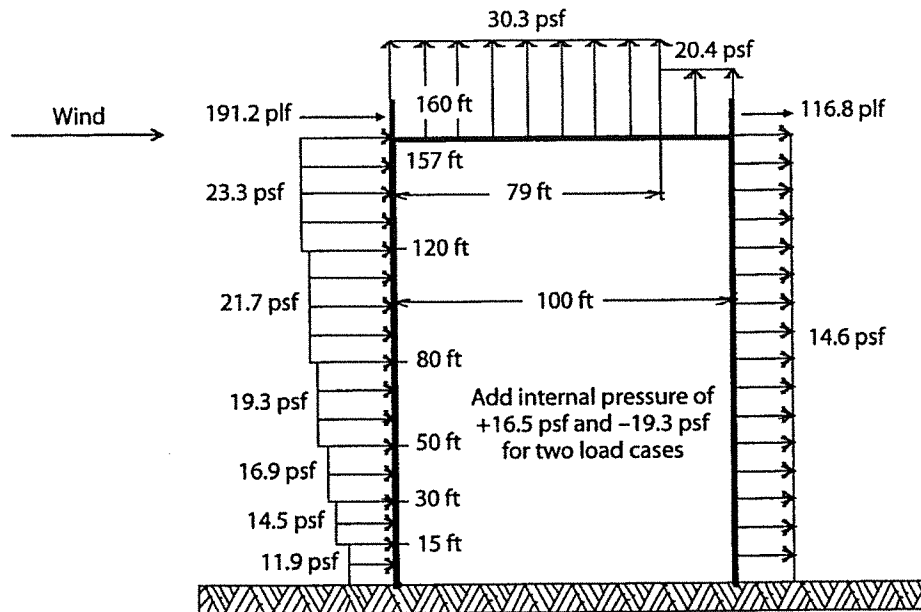
Mullion:

larger of

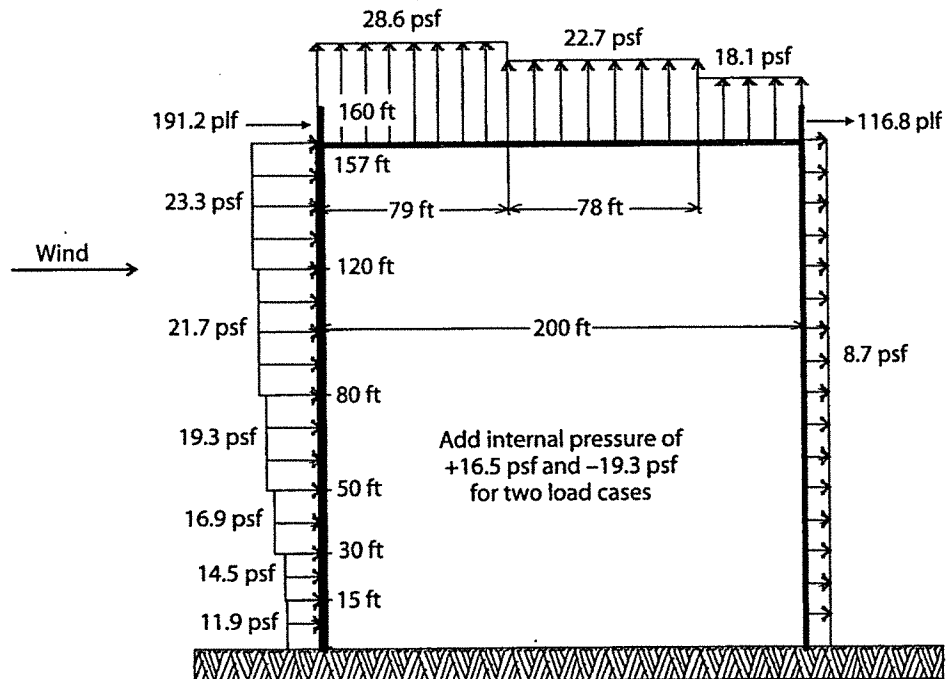
$$A = 11(5) = 55 \text{ ft}^2 \text{ (controls)}$$

or

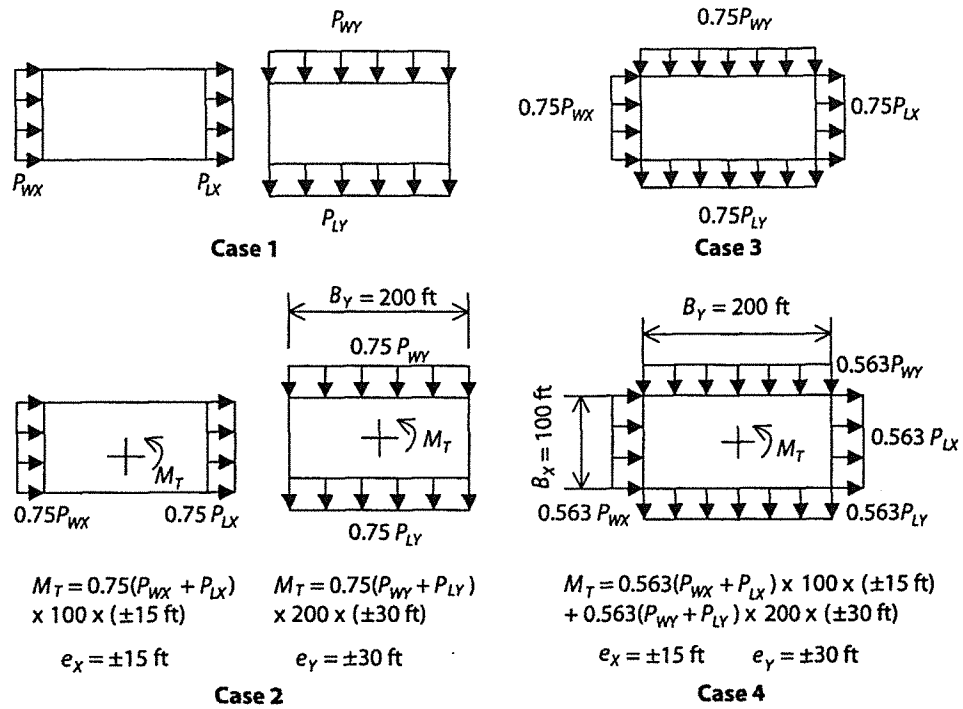
$$A = 11(11/3) = 40.3 \text{ ft}^2$$



**Figure 3-7** Pressures for MWFRS for Wind Normal to the 200-ft Face



**Figure 3-8** Pressures for MWFRS for Wind Normal to 100-ft Face



**Figure 3-9** Pressures in Case B for MWFRS for Wind Normal to 100-ft Face

**Table 3-8** Wall ( $GC_p$ ) for Ex. 3

Component	A ( $\text{ft}^2$ )	$GC_p$		
		Zones 4 and 5 ( $+GC_p$ )	Zone 4 ( $-GC_p$ )	Zone 5 ( $-GC_p$ )
Mullion	55	0.81	-0.84	-1.55
Panel	27.5	0.87	-0.88	-1.72

Glazing panel:

larger of

$$A = 5(5.5) = 27.5 \text{ ft}^2 \text{ (controls)}$$

or

$$A = 5(5/3) = 8.3 \text{ ft}^2$$

Width of corner Zone 5:

larger of

$$a = 0.1(100) = 10 \text{ ft (controls)}$$

or

$$a = 3 \text{ ft}$$

The internal pressure coefficient ( $GC_{pi}$ ) =  $\pm 0.55$

(Figure 6-5)

**Typical Design Pressure Calculations**  
(Tables 3-9 and 3-10)

Controlling negative design pressure for mullion in Zone 4 of walls:

$$= 35.1(-0.84) - 30 \times 0.55$$

$$= -46.0 \text{ psf (positive internal pressure controls)}$$

**Table 3-9** Controlling Design Pressures for Mullions (psf)

<i>z</i> (ft)	<i>Design pressure</i>			
	<i>Zone 4</i>		<i>Zone 5</i>	
	<i>Positive</i>	<i>Negative</i>	<i>Positive</i>	<i>Negative</i>
0–15	37.0	–46.0	37.0	–70.9
15–30	37.0	–46.0	37.0	–70.9
30–50	39.9	–46.0	39.9	–70.9
50–80	42.9	–46.0	42.9	–70.9
80–120	45.7	–46.0	45.7	–70.9
120–157	47.7	–46.0	47.7	–70.9

**Table 3-10** Design Pressures of Panels (psf)

<i>z</i> (ft)	<i>Design pressure</i>			
	<i>Zone 4</i>		<i>Zone 5</i>	
	<i>Positive</i>	<i>Negative</i>	<i>Positive</i>	<i>Negative</i>
0–15	38.4	–47.4	38.4	–76.9
15–30	38.4	–47.4	38.4	–76.9
30–50	41.4	–47.4	41.4	–76.9
50–80	44.6	–47.4	44.6	–76.9
80–120	47.7	–47.4	47.7	–76.9
120–157	49.8	–47.4	49.8	–76.9

Controlling positive design pressure for mullion in Zone 4 of walls at roof height:

$$\begin{aligned}
 &= 35.1 \times 0.81 - 35.1 \times (-0.55) \\
 &= 47.7 \text{ psf (negative internal pressure controls)}
 \end{aligned}$$

Controlling negative pressure is obtained with positive internal pressure, and controlling positive pressure is obtained with negative internal pressure.

#### Parapet Design Pressures

The design wind pressure on the C&C elements of parapets shall be determined according to the following equation (Section 6.5.12.4.4 of the Standard). In this example, the effective wind area is assumed to be 3 ft × 3 ft = 9 ft<sup>2</sup>.

$$p = q_p (GC_p - GC_{pi}) \quad (\text{Eq. 6-24})$$

where

- $q_p$  = Velocity pressure evaluated at the top of parapet
- $GC_p$  = External pressure coefficient from Figures 6-11 through 6-17 of the Standard
- $GC_{pi}$  = Internal pressure coefficient from Figure 6-5 of the Standard, based on the porosity of the parapet envelope. In this example, internal pressure is not included since parapet is assumed to be nonporous.

Note that, according to Note 7 of Figure 6-17, Zone 3 is treated as Zone 2.

Load Case A:

$$35.4 \times [(0.9) - (-2.3)] = 113.3 \text{ psf (directed inward)}$$

Load Case B:

$$35.4 \times [(0.9) - (-1.8)] = 95.6 \text{ psf (directed outward)}$$

### Roof Design Pressures

The C&C roof pressure coefficients are given in Figure 6-17 of the Standard. The pressure coefficients (Table 3-11) are a function of the effective wind area. Since specific components of roofs are not identified, design pressures are given for various effective wind areas,  $A$ .

The design pressures are the algebraic sum of external and internal pressures. Positive internal pressure provides controlling negative pressures. These design pressures act across the roof surface (interior to exterior):

$$\text{Design internal pressures} = 30 \times 0.55 = 16.5 \text{ psf}$$

$$\text{Design pressures} = q_h (GC_p) - 16.5 = 35.1 (GC_p) - 16.5$$

Design pressures are summarized in Table 3-12.

**Table 3-11** Roof External Pressure Coefficient ( $GC_p$ )

$A$ ( $ft^2$ )	Zone 1	Zones 2 and 3
	$GC_p$	$-GC_p^*$
$\leq 10$	-1.40	-2.30
20	-1.31	-2.18
100	-1.11	-1.89
250	-0.99	-1.72
400	-0.93	-1.64
$\geq 500$	-0.90	-1.60

\*Note 7 in Figure 6-17 of the Standard permits treatment of Zone 3 as Zone 2 if parapet of 3 ft or higher is provided.

**Table 3-12** Roof Design Pressures (psf)

$A$ ( $ft^2$ )	Design pressures negative	
	Zone 1	Zones 2 and 3
$\leq 10$	-65.6	-97.2
20	-62.5	-93.0
100	-55.5	-82.8
250	-51.2	-76.9
400	-49.1	-74.1
500	-48.1	-72.7

### 3.4 Example 4 Office Building of Ex. 3 Located on an Escarpment

In this example, velocity pressures for the office building of Ex. 3, when it is located on an escarpment, are determined. Design pressures for MWFRS and C&C can be determined in the same manner as Ex. 3 once velocity pressures  $q_z$  and  $q_h$  are determined. The building is illustrated in Figure 3-10; data are provided below.

<i>Location:</i>	City in Alaska
<i>Topography:</i>	Escarpment as shown
<i>Terrain:</i>	Suburban
<i>Dimensions:</i>	100 ft × 200 ft in plan Roof height of 157 ft with 3-ft parapet Flat roof
<i>Framing:</i>	Reinforced concrete rigid frame in both directions Floor and roof slabs provide diaphragm action Fundamental natural frequency is greater than 1 Hz
<i>Cladding:</i>	Mullions for glazing panels span 11 ft between floor slabs Mullion spacing is 5 ft

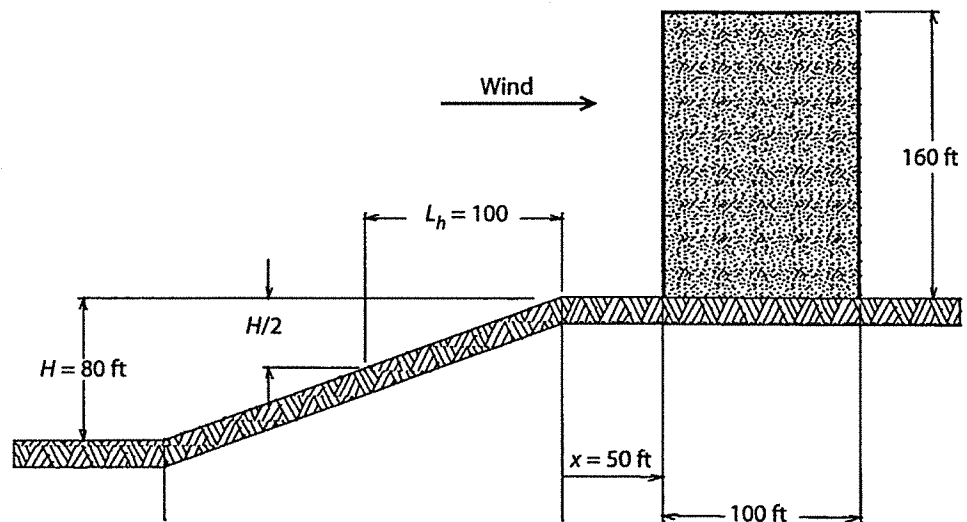
Glazing panels are 5-ft wide × 5-ft 6 in. high (typical). Glazing does not have to be wind-borne debris impact resistant because Alaska is not in a hurricane-prone region (see Section 6.5.9.3 of the Standard).

#### Exposure, Building Classification, and Basic Wind Speed

Same as Ex. 3: Exposure B  
Category II  
 $V = 120$  mph, same as Ex. 3

#### Velocity Pressures

The velocity pressure equation is:



**Figure 3-10** Office Building on Escarpment

Notes: 1)  $L_h$  is measured from mid-height to top of the slope. 2)  $x$  distance is taken to the front of the building as a conservative value.

**Table 3-13** Speed-up Velocity Pressures (psf)

Height (ft)	$K_z$	$z/L_h^*$	$K_3$	$K_{zt}$	$q_z$ (psf)
0-15	0.57	0.05	0.88	1.71	30.5
30	0.70	0.14	0.71	1.56	34.2
50	0.81	0.25	0.54	1.41	35.8
80	0.93	0.41	0.36	1.27	37.0
120	1.04	0.63	0.21	1.15	37.5
$h = 157$	$K_h = 1.12$	0.87	0.11	1.08	37.9

\* $z$  is taken midway between the height range because it is unconservative for  $K_{zt}$  to take top height of the range.  $L_h = 160$  ft.

$$q_z = 0.00256 K_z K_{zt} K_d V^2 I \text{ psf}$$

For this example,  $K_z$  is obtained from Table 6-3 of the Standard, and  $K_{zt}$  is determined using Figure 6-4.  $K_d = 0.85$  from Table 6-4 of the Standard;  $I = 1.0$  for Category II from Table 6-1 and  $V = 120$  mph.

#### Determination of $K_{zt}$

The topographic effect of escarpment applies only when the upwind terrain is free of topographic features for a distance equal to  $100 H$  or  $2$  mi, whichever is smaller. For this example, it is assumed that there are no topographic features upwind for a distance of  $8,000$  ft.

For use in Figure 6-4 of the Standard:

$$H = 80 \text{ ft}$$

$$L_h = 100 \text{ ft}$$

$$x = 50 \text{ ft (distance to the front face of the building)}$$

Since  $H/L_h = 0.8 > 0.5$ , according to Note 2 in Figure 6-4 of the Standard, use  $H/L_h = 0.5$  and  $L_h = 2H = 160$  ft.

The building is on a 2-D escarpment.

For Exposure B,

$$K_1/(H/L_h) = 0.75, \text{ therefore } K_1 = (0.75)(0.5) = 0.38 \quad (\text{Figure 6-4})$$

For  $x/L_h = 50 \text{ ft}/160 \text{ ft} = 0.31$ ;

$$K_2 = [1 - (0.31/4)] = 0.92 \quad (\text{Figure 6-4})$$

$$K_3 = e^{-2.5z/L_h} \quad (\text{values in table for } z)$$

$$K_{zt} = (1 + K_1 K_2 K_3)^2 \quad (\text{Eq. 6-3})$$

$$q_z = 0.00256 K_z K_{zt} (0.85) (120)^2 (1.0)$$

Values for  $q_z$  are shown in Table 3-13.

#### Effect of Escarpment

Velocity pressures  $q_z$  are compared with the values of Ex. 3 in Table 3-14 to assess the effect of the escarpment. The increase in velocity pressures does not directly translate into an increase in design pressures as discussed below.

**Table 3-14** Velocity Pressure  $q_z$  (psf)

<i>Height (ft)</i>	<i>Homogeneous terrain (Ex. 3)</i>	<i>Escarpment (Ex. 4)</i>	<i>% Increase</i>
0–15	17.9	30.5	71
30	21.9	34.2	56
50	25.4	35.8	41
80	29.1	37.0	27
120	32.6	37.5	15
157 (roof)	35.1	37.9	8

For MWFRS, the external windward wall pressures will increase by the percentages shown at various heights; however, the external leeward wall, side wall, and roof pressures will increase by 8% since these pressures are controlled by velocity pressure at roof height,  $q_h$ . Internal pressures will depend on assessment of openings.

For C&C, the negative (outward acting) external pressures will also increase by only 8%.

### 3.5 Example 5 2,500-ft<sup>2</sup> House with Gable/Hip Roof

Design wind pressures for a typical one-story house are to be determined. Various views of the house are provided in Figure 3-11(a) through 3-11(d). The physical data are as follows:

<i>Location:</i>	Dallas–Fort Worth, Texas
<i>Topography:</i>	Homogeneous
<i>Terrain:</i>	Suburban
<i>Dimensions:</i>	80 ft × 40 ft (including porch) footprint Porch is 8 ft × 48 ft Wall eave height is 10 ft Roof gable $\theta = 15^\circ$ ; roof overhang is 2 ft all around
<i>Framing:</i>	Typical timber construction Wall studs are spaced 16 in. on center Roof trusses spanning 32 ft are spaced 4 ft on center Roof panels are 4 ft × 8 ft

Glazing is uniformly distributed (pressures on C&C will depend on effective area and location; for brevity, all items are not included).

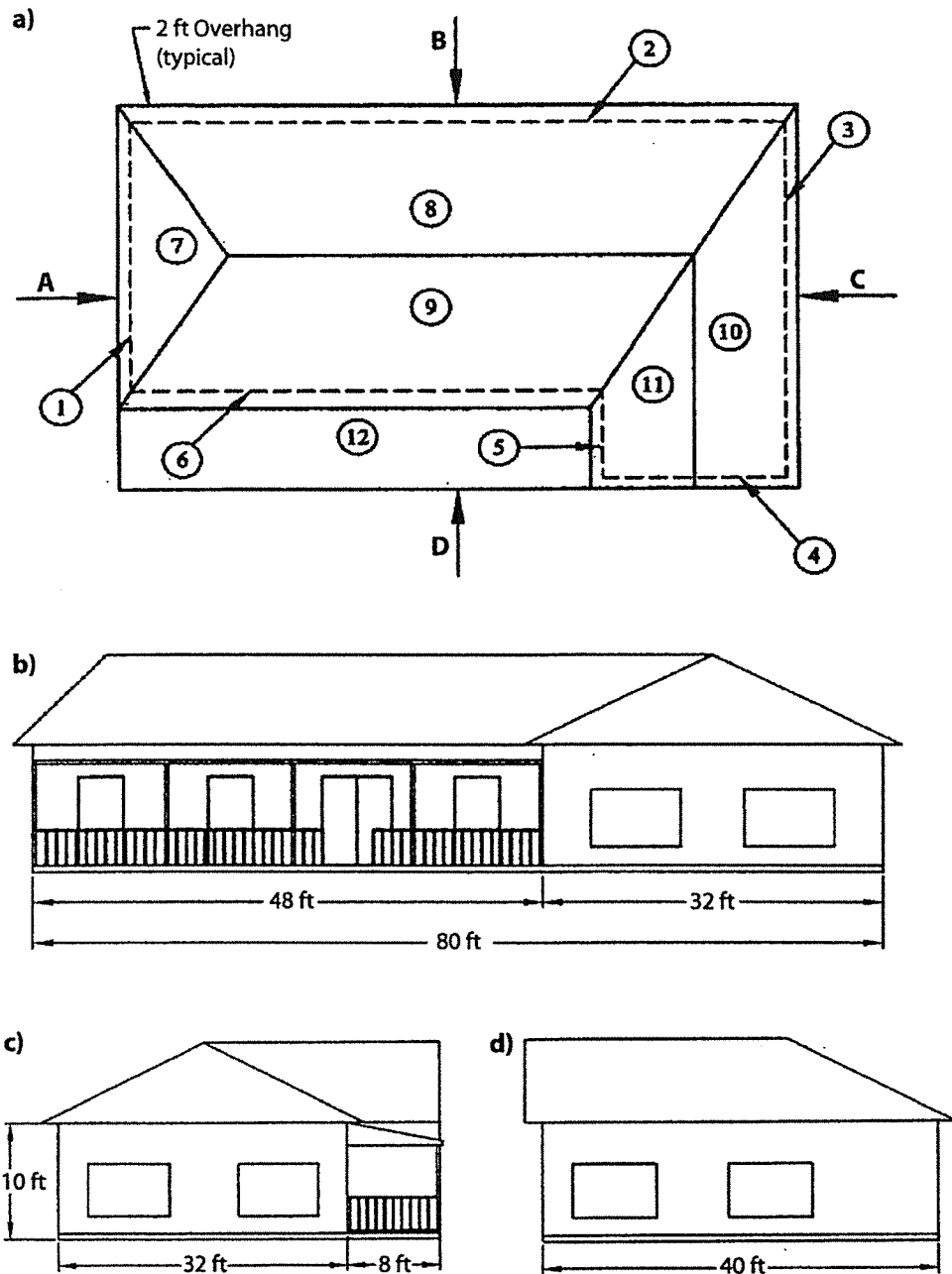
Wind speed  $V = 90$  mph

Importance factor  $I = 1.0$

Topography factor  $K_{zt} = 1.0$

Directionality factor  $K_d = 0.85$  (for buildings)

The building is located in a suburban area; according to Section 6.5.6.2 and 6.5.6.3 of the Standard, Exposure B is used.



**Figure 3-11** a, View of Roof of 2,500-ft<sup>2</sup> House; b, Front View D; c, Side View A; d, Side View C

$$\text{mean roof height} = 10 + \frac{(16)(\tan 15^\circ)}{2} = 12.1 \text{ ft}$$

Since  $K_z$  is constant in the 0 to 15 ft region, from Table 6-3 of the Standard:

$$K_z = K_h = 0.70 \text{ for Case 1 (C\&C)}$$

$$K_z = K_h = 0.57 \text{ for Case 2 (MWFRS)}$$

Velocity Pressures

$$q_z = 0.00256 K_z K_{zt} K_d V^2 I \text{ psf} \quad (\text{Eq. 6-15})$$

For MWFRS,

$$q_z = q_h = 0.00256 (0.57) (1.0) (0.85) (90)^2 (1.0) = 10.1 \text{ psf}$$

For C&C,

$$q_z = q_h = 0.00256 (0.7) (1.0) (0.85) (90)^2 (1.0) = 12.3 \text{ psf}$$

Gust Effect Factor

$$G = 0.85$$

(Section 6.5.8.1)

$$(GC_{pi}) = +0.18 \text{ and } -0.18$$

(Figure 6-5)

Wind Pressure for MWFRS

Because of asymmetry, all four wind directions are considered (normal to walls).

The wall surfaces are numbered 1 through 6; roof surfaces are 7 through 11; porch roof surface is 12.

#### Wind Direction A

Wall pressures:

$$\text{Surface 1: } p = 10.1(0.85)(0.8) - 10.1(\pm 0.18) = +6.9 \pm 1.8 \text{ psf (windward)}$$

$$\text{Surface 2: } p = 10.1(0.85)(-0.7) - 10.1(\pm 0.18) = -6.0 \pm 1.8 \text{ psf (side)}$$

$$\text{Surface 3: } p = 10.1(0.85)(-0.3) - 10.1(\pm 0.18) = -2.6 \pm 1.8 \text{ psf (leeward)}$$

(for  $L/B = 80/40 = 2$ ;  $C_p = -0.3$ )

$$\text{Surface 4: } p = -6.0 \pm 1.8 \text{ psf (side)}$$

$$\text{Surface 5: } p = +6.9 \pm 1.8 \text{ psf (windward)}$$

$$\text{Surface 6: } p = -6.0 \pm 1.8 \text{ psf (side)}$$

Roof pressures:

Roof  $C_p$  from Figure 6-3 of the Standard are shown in Table 3-15:

**Table 3-15** Roof  $C_p$ \* for Wind Direction A

Surface	7	8	9	10	11	12
$C_p$	-0.5 0.0*	Horiz. distance from windward edge	Same as surface 8	-0.5 -0.5*	-0.5 0.0*	Same as surface 8
		1 to 12.1 ft	12.1 to 24.2 ft	24.2 ft to end		
		-0.9 -0.18*	-0.5 -0.18*	-0.3 -0.18*		

\*The values of smaller uplift pressures on the roof can become critical when wind load is combined with roof live load or snow load; load combinations are given in Sections 2.3 and 2.4 of the Standard. For brevity, loading for this value is not shown here.

Roof pressures calculation:

$$\text{Surface 7: } p = 10.1(0.85)(-0.5) - 10.1(\pm 0.18) = -4.3 \pm 1.8 \text{ psf (windward)}$$

Surface 8: for  $\theta = 0^\circ$ ; pressure varies along the roof

$$p = 10.1(0.85)(-0.9) - 10.1(\pm 0.18) = -7.7 \pm 1.8 \text{ psf; 1 to 12.1 ft}$$

$$p = 10.1(0.85)(-0.5) - 10.1(\pm 0.18) = -4.3 \pm 1.8 \text{ psf; 12.1 to 24.2 ft}$$

$$p = 10.1(0.85)(-0.3) - 10.1(\pm 0.18) = -2.6 \pm 1.8 \text{ psf; 24.2 ft to end}$$

Surface 9: Same pressures as surface 8

$$\text{Surface 10: } p = 10.1(0.85)(-0.5) - 10.1(\pm 0.18) = -4.3 \pm 1.8 \text{ psf (leeward)}$$

$$\text{Surface 11: } p = 10.1(0.85)(-0.5) - 10.1(\pm 0.18) = -4.3 \pm 1.8 \text{ (windward)}$$

Surface 12: Same as surface 8 without internal pressure

Overhang pressures:

At wall surfaces 1 and 5:

$$p = 10.1 (0.85) (0.8) = +6.9 \text{ psf}$$

Internal pressure is of the same sign on all applicable surfaces.

Wind Direction B

Wall pressures:

$$\text{Surface 1: } p = -6.0 \pm 1.8 \text{ psf (side)}$$

$$\text{Surface 2: } p = +6.9 \pm 1.8 \text{ psf (windward)}$$

$$\text{Surface 3: } p = -6.0 \pm 1.8 \text{ psf (side)}$$

$$\text{Surface 4: } p = 10.1(0.85)(-0.5) - 10.1(\pm 0.18) = -4.3 \pm 1.8 \text{ psf (leeward)} \\ \text{(for } L/B = 40/80 = 0.5; C_p = -0.5)$$

Surface 5: Even though technically this surface is side wall, it is likely to see the same pressure as surface 6

Surface 6: Same pressure as surface 4

Roof pressures:

$$h/L = 12.1/40 = 0.3; \theta = 15^\circ$$

Roof  $C_p$  from Figure 6-6 of the Standard are tabulated in Table 3-16:

For windward,  $C_p = -0.54$  (interpolated between  $-0.5$  and  $-0.7$ )

For leeward,  $C_p = -0.5$

For parallel to ridge:

$$C_p = -0.9; 1 \text{ to } 12.1 \text{ ft}$$

$$C_p = -0.5; 12.1 \text{ to } 24.2 \text{ ft}$$

$$C_p = -0.3; 24.2 \text{ ft to end}$$

**Table 3-16** Roof  $C_p$  for Wind Direction B

Surface	7	8	9	10	11	12
$C_p$	Same as surface 8 for Wind Direction A	-0.54*	-0.5	Same as surface 8 for Wind Direction A	Same as surface 9	-0.3

\* Value is gained by interpolation.

**Roof pressures calculation:**

Surface 7: Same pressures as surface 8 for Wind Direction A

Surface 8:  $p = 10.1(0.85)(-0.54) - 10.1(\pm 0.18) = -4.6 \pm 1.8$  psf (windward)

Surface 9:  $p = 10.1(0.85)(-0.5) - 10.1(\pm 0.18) = -4.3 \pm 1.8$  psf (leeward)

Surface 10: Same pressures as surface 8 for Wind Direction A

Surface 11: Same as surface 9 because it is sloping with respect to ridge

Surface 12: This surface is at a distance greater than  $2h$

$p = 10.1(0.85)(-0.3) = -2.6$  psf; no internal pressure

**Overhang pressures:**

At wall surface 2:

$p = 10.1(0.85)(0.8) = +6.9$  psf

Internal pressure is of the same sign on all applicable surfaces.

**Wind Direction C****Wall pressures:**

Surfaces 1 and 5:  $p = -2.6 \pm 1.8$  psf (leeward)

Surfaces 2, 4, and 6:  $p = -6.0 \pm 1.8$  psf (side)

Surface 3:  $p = +6.9 \pm 1.8$  psf (windward)

**Roof pressures:**

Surfaces 7 and 11:  $p = -4.3 \pm 1.8$  psf (leeward)

Surfaces 8 and 9: Pressures vary along the roof; same pressures as surface 8 for Wind Direction A

Surface 10:  $p = -4.3 \pm 1.8$  psf (windward)

Surface 12: Same pressures as surface 9 without internal pressures

**Overhang pressures:**

At wall surface 3

$p = 10.1(0.85)(0.8) = +6.9$  psf

Internal pressure is of the same sign on all applicable surfaces.

## Wind Direction D

### Wall pressures:

Surfaces 1 and 3:  $p = -6.0 \pm 1.8$  psf (side)

Surface 2:  $p = -4.3 \pm 1.8$  psf (leeward)

Surfaces 4, 5, and 6:  $p = +6.9 \pm 1.8$  psf (windward)

### Roof pressures:

Surfaces 7, 10, and 11: Pressures vary along the roof; same pressures as surface 8 for Wind Direction A

Surface 8:  $p = -4.3 \pm 1.8$  psf (leeward)

Surface 9:  $p = -4.3 \pm 1.8$  psf (windward)

Surface 12: This surface will see pressures on top and bottom surfaces; they will add algebraically.

For  $\theta = 0^\circ$ ,  $h/L < 0.5$ ,  $C_p = -0.9$  (Load Case 1)

$$p = 10.1(0.85)(-0.9) - 10.1(0.85)(+0.8) = -14.6 \text{ psf uplift}$$

### Overhang pressures:

At wall surfaces 4, 5, and 6:

$$p = 10.1(0.85)(0.8) = +6.9 \text{ psf}$$

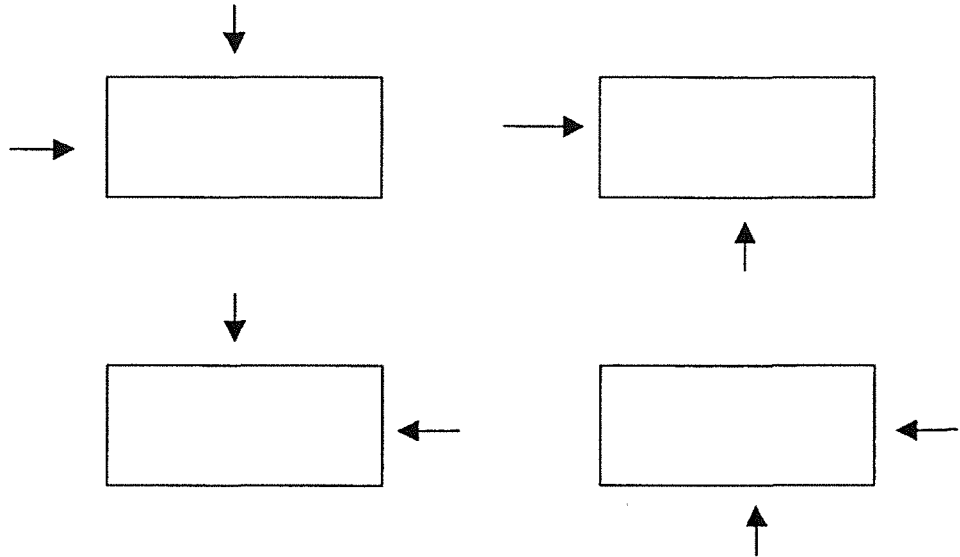
Internal pressure is of the same sign on all applicable surfaces.

## Design Wind Load Cases

Section 6.5.12.3 of the Standard requires that any building whose wind loads have been determined under the provisions of Sections 6.5.12.2.1 and 6.5.12.2.3 shall be designed for wind load cases as defined in Fig. 6-9. Case 1 includes the loadings analyzed above. A combination of windward ( $P_W$ ) and leeward ( $P_L$ ) loads is applied for other Load Cases. This building has mean roof height  $h$  of less than 30 ft; hence it comes under exception specified in Section 6.5.12.3 of the standard. Only Load Cases 1 and 3 shown in Figure 6-9 of the Standard have to be considered.

The following two points need to be highlighted:

1. Because of asymmetry, all four wind directions are considered when combining wind loads according to Figure 6-9 of the Standard. For example, when combining wind loads in Case 3, there are four kinds of combinations of wind loads that need to be considered, which are shown as in Figure 3-12.
2. Due to the slightness of the roof slope, the wind load acted on the roof is negligible here.



**Figure 3-12** Combinations of Wind Loads  
 Note: Arrows show the wind directions.

### Design Pressures for C&C

#### Wall Component

Wall studs are 10-ft long and spaced 16 in. apart.

Effective area:

larger of

$$10 \times 1.33 = 13.3 \text{ ft}^2$$

or

$$10 \times 10/3 = 33.3 \text{ ft}^2 \text{ (controls)}$$

From Figure 6-11A of the Standard, equations in Chapter 2 of this guide are used:

$$(GC_p) = +0.91 \text{ for Zones 4 and 5}$$

$$(GC_p) = -1.01 \text{ for Zone 4}$$

$$(GC_p) = -1.22 \text{ for Zone 5}$$

Distance "a":

smaller of

$$0.1 (40) = 4 \text{ ft (controls)}$$

or

$$0.4 (12.1) = 4.8 \text{ ft}$$

Design pressure:

$$p = 12.3 (0.91 + 0.18) = +13.4 \text{ psf (all walls)}$$

$$p = 12.3 (-1.01 - 0.18) = -14.6 \text{ psf (middle)}$$

$$p = 12.3 (-1.22 - 0.18) = -17.2 \text{ psf (corner)}$$

## Roof Component

Distance "a":

smaller of

$$0.1 (40) = 4 \text{ ft (controls)}$$

or

$$0.4 (12.1) = 4.8 \text{ ft}$$

Roof trusses are 32 ft long and spaced 4 ft apart.

Effective area:

larger of

$$32 \times 4 = 128 \text{ ft}^2$$

or

$$32 \times 32/3 = 341 \text{ ft}^2 \text{ (controls)}$$

From Figure 6-11C of the Standard, for  $\theta = 15^\circ$ :

$(GC_p) = +0.3$  for Zones 1, 2, and 3 (Note: Zone 3 covers very small area of truss)

$(GC_p) = -0.8$  for Zone 1

$(GC_p) = -2.2$  for Zone 2

Design pressures:

$$p = 12.3 (0.3 + 0.18) = +5.9 \text{ psf (all zones)}$$

$$p = 12.3 (-0.8 - 0.18) = -12.1 \text{ psf (Zone 3)}$$

$$p = 12.3 \times (-2.2) = -27.1 \text{ psf (Zone 2)}$$

Overhang pressures to be used for reaction and anchorage:

$$p = 12.3 (-2.2) = -27.1 \text{ psf (edge of roof)}$$

$$p = 12.3 (-2.5) = -30.8 \text{ psf (roof corners)}$$

## Roof Panels

Effective area =  $4 \times 8 = 32 \text{ ft}^2$

From Figure 6-11C of the Standard, for  $\theta = 15^\circ$  (Note: Zones 2 and 3 are regarded as overhang):

$(GC_p) = +0.4$  for Zones 1, 2, and 3

$(GC_p) = -0.85$  for Zone 1

$(GC_p) = -2.2$  for Zone 2 (with overhang)

$(GC_p) = -2.2$  for Zone 3 on hip roofs (with overhang)

$(GC_p) = -3.1$  for Zone 3 on gable roofs (with overhang)

Design pressures:

$$p = 12.3 (0.4 + 0.18) = +7.1 \text{ psf (all zones)}$$

$$p = 12.3 \times (-0.85 - 0.18) = -12.7 \text{ psf (Zone 1)}$$

$$p = 12.3 \times (-2.2) = -27.1 \text{ psf (Zone 2)}$$

$$p = 12.3 \times (-2.2) = -27.1 \text{ psf (Zone 3 on hip roofs)}$$

$$p = 12.3 \times (-3.1) = -38.1 \text{ psf (Zone 3 on gable roofs)}$$

## Fasteners

Effective area = 10 ft<sup>2</sup>:

$$(GC_p) = +0.5 \text{ for Zones 1, 2, and 3}$$

$$(GC_p) = -0.9 \text{ for Zone 1}$$

$$(GC_p) = -2.2 \text{ for Zone 2 (with overhang)}$$

$$(GC_p) = -2.2 \text{ for Zone 3 on hip roofs (with overhang)}$$

$$(GC_p) = -3.7 \text{ for Zone 3 on gable roofs (with overhang)}$$

Design pressures:

$$p = 12.3 (0.5 + 0.18) = +8.4 \text{ psf (all zones)}$$

$$p = 12.3 \times (-0.9 - 0.18) = -13.3 \text{ psf (Zone 1)}$$

$$p = 12.3 \times (-2.2) = -27.1 \text{ psf (Zone 2)}$$

$$p = 12.3 \times (-2.2) = -27.1 \text{ psf (Zone 3 on hip roofs)}$$

$$p = 12.3 \times (-3.7) = -45.5 \text{ psf (Zone 3 on gable roofs)}$$

### 3.6 Example 6 200-ft × 250-ft Gable Roof Commercial/Warehouse Building Using Buildings of All Height Provisions

In this example, design wind pressures for a large, one-story commercial/warehouse building are determined. Figure 3-13 shows the dimensions and framing of the building. The building data are as follows:

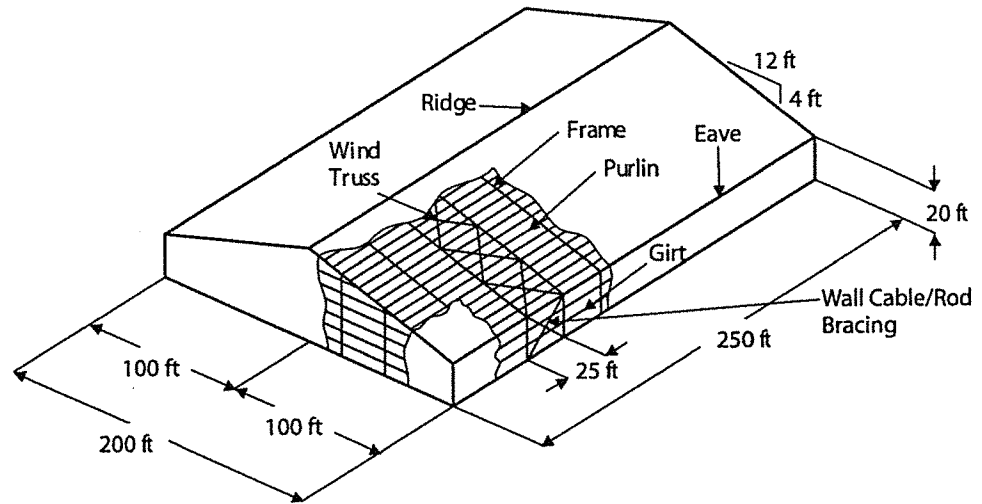
---

<i>Location:</i>	Memphis, Tennessee
<i>Terrain:</i>	Flat farmland
<i>Dimensions:</i>	200 ft × 250 ft in plan Eave height of 20 ft Roof slope 4:12 (18.4°)
<i>Framing:</i>	Rigid frames span the 200-ft direction Rigid frame bay spacing is 25 ft Lateral bracing in the 250-ft direction is provided by a "wind truss" spanning the 200 ft to side walls and cable/rod bracing in the planes of the walls Girts and purlins span between rigid frames (25-ft span) Girt spacing is 6 ft 8 in. Purlin spacing is 5 ft
<i>Cladding:</i>	Roof panel dimensions are 2 ft wide Roof fastener spacing on purlins is 1 ft on center Wall panel dimensions are 2 ft × 20 ft Wall fastener spacing on girts is 1 ft on center Openings are uniformly distributed

---

## Exposure and Building Classification

The building is located on flat and open farmland. It does not fit Exposures B or D; therefore, Exposure C is used (Sections 6.5.6.2 and 6.5.6.3 of the Standard).



**Figure 3-13** Dimensions and Framing of the Building of Examples 6 and 7

The building function is commercial-industrial. It is not considered an essential facility or likely to be occupied by 300 persons at one time. Category II is appropriate. Table 1-1 and Table 6-1 of the Standard specify an importance factor  $I = 1.0$ .

**Basic Wind Speed**

Selection of basic wind speed is addressed in Section 6.5.4 of the Standard. Memphis, Tennessee, is not located in the special wind region, nor is there any reason to suggest that winds at the site are unusual and require additional attention. Therefore, the basic wind speed is  $V = 90$  mph (see Figure 6-1 of the Standard).

**Analytical Procedure**

Method 2, Analytical Procedure, is used in this example (see Section 6.5 of the Standard). In addition, provisions of buildings of all heights, given in Section 6.5.12.2.1 and Figure 6-6 for MWFRS, will be used. Alternate provisions of low-rise buildings are illustrated in Ex. 7 (Section 3.7 of this guide).

**Wind Directionality**

Wind directionality factor is given in Table 6-4 of the Standard. For MWFRS and C&C, the factor  $K_d = 0.85$ .

**Velocity Pressures  
(Table 3-17)**

The velocity pressures are computed using the following equation:

$$q_z = 0.00256 K_z K_{zt} K_d V^2 I \text{ psf} \quad (\text{Eq. 6-15})$$

where

- $K_z$  = Value obtained from Table 6-3 of the Standard
- $K_{zt}$  = 1.0 (no topographic effect)
- $I$  = 1.0 for Category II building
- $K_d$  = 0.85
- $V$  = 90 mph

Substituting these values into Eq. 6-15 yields:

$$\begin{aligned} q_z &= 0.00256 K_z (1.0) (0.85) (90)^2 (1.0) \\ &= 17.6 K_z \text{ psf} \end{aligned}$$

**Table 3-17** Velocity Pressures (psf)

Height	ft	$K_z$	$q_z$ (psf)
	0-15	0.85	15.0
Eave	20	0.90	15.8
	30	0.98	17.3
$h$	36.7	1.02	18.0*
	40	1.04	18.3
	50	1.09	19.2
Ridge	53.3	1.10	19.4

\* $q_h = 18.0$  psf.

Values for  $K_z$  are the same for Cases 1 and 2 for Exposure C (see Table 6-3 of the Standard). Mean roof height  $h = 36.7$  ft.

### Design Wind Pressure

Design wind pressures for MWFRS of this building can be obtained using Section 6.5.12.2.1 of the Standard for buildings of all heights or Section 6.5.12.2.2 for low-rise buildings. Pressures determined in this example are using buildings of all heights criteria. Ex. 7 illustrates use of low-rise building criteria.

$$p = qGC_p - q_i(GC_{pi}) \quad (\text{Eq. 6-17})$$

where

- $q$  =  $q_z$  for windward wall at height  $z$  above ground
- $q$  =  $q_h$  for leeward wall, side walls, and roof
- $q_i$  =  $q_h$  for enclosed buildings
- $G$  = Gust effect factor
- $C_p$  = Values obtained from Figure 6-6 of the Standard
- $(GC_{pi})$  = Values obtained from Figure 6-5

For this example, when the wind is normal to the ridge, the windward roof experiences both positive and negative external pressures. Combining these external pressures with positive and negative internal pressures will result in four loading cases when wind is normal to the ridge.

When wind is parallel to the ridge, positive and negative internal pressures result in two loading cases. The external pressure coefficients,  $C_p$  for  $\theta = 0^\circ$ , apply in this case.

### Gust Effect Factor

For rigid structures,  $G$  can be calculated using Eq. 6-4 (see Section 6.5.8:1 of the Standard) or alternatively taken as 0.85. For simplicity,  $G = 0.85$  is used in this example.

### External Wall $C_p$ from Figure 6-6

The pressure coefficients for the windward wall and for the side walls are 0.8 and  $-0.7$ , respectively, for all  $L/B$  ratios.

The leeward wall pressure coefficient is a function of the  $L/B$  ratio. For wind normal to the ridge,  $L/B = 200/250 = 0.8$ ; therefore, the leeward wall

**Table 3-18** External Wall  $C_p$ 

Surface	Wind direction	L/B	$C_p$
Windward wall	All	All	0.80
Leeward wall	Normal to ridge	0.8	-0.50
	Parallel to ridge	1.25	-0.45*
Side wall	All	All	-0.70

\*By linear interpolation.

**Table 3-19** Roof  $C_p$  (Wind Normal to Ridge)

Surface	15°	18.4°	20°
Windward roof	-0.5	-0.36*	-0.3
	0.0	0.14*	0.2
Leeward roof	-0.5	-0.57*	-0.6

\*By linear interpolation.

pressure coefficient is -0.5. For flow parallel to the ridge,  $L/B = 250/200 = 1.25$ ; the value of  $C_p$  is obtained by linear interpolation. The wall pressure coefficients are summarized in Table 3-18.

External Roof  $C_p$  from  
Figure 6-6 (Wind Normal  
to Ridge)

The roof pressure coefficients for the MWFRS (Table 3-19) are obtained from Figure 6-6 of the Standard. For the roof angle of 18.4°, linear interpolation is used to establish  $C_p$ . For wind normal to the ridge,  $h/L = 36.7/200 = 0.18$ ; hence, only single linear interpolation is required. Note that interpolation is only carried out between values of the same sign.

Internal  $GC_{pi}$

Values for  $GC_{pi}$  for buildings are addressed in Section 6.5.11.1 and Figure 6-5 of the Standard.

The openings are evenly distributed in the walls (enclosed building) and Memphis, Tennessee, is not in a hurricane-prone region. The reduction factor of Section 6.5.11.1.1 is not applicable for enclosed buildings; therefore,

$$GC_{pi} = \pm 0.18$$

MWFRS Net Pressures

$$p = qGC_p - q_i(GC_{pi}) \quad (\text{Eq. 6-17})$$

$$p = q(0.85)C_p - 18.0(\pm 0.18)$$

where

$$q = q_z \text{ for windward wall}$$

$$q = q_h \text{ for leeward wall, side wall, and roof}$$

$$q_i = q_h \text{ for windward walls, side walls, leeward walls, and roofs of enclosed buildings}$$

Typical Calculation

Windward wall, 0–15 ft, wind normal to ridge:

$$p = 15.0(0.85)(0.8) - 18.0(\pm 0.18)$$

$p = 7.0$  psf with (+) internal pressure

$p = 13.4$  psf with (-) internal pressure

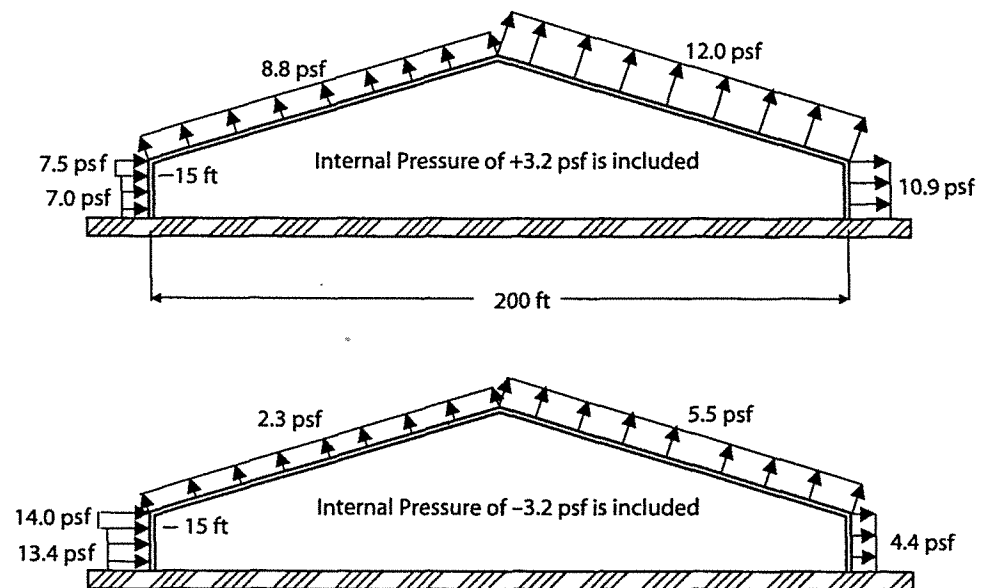
The net pressures for the MWFRS are summarized in Table 3-20.

**Table 3-20** MWFRS Pressures: Wind Normal to Ridge

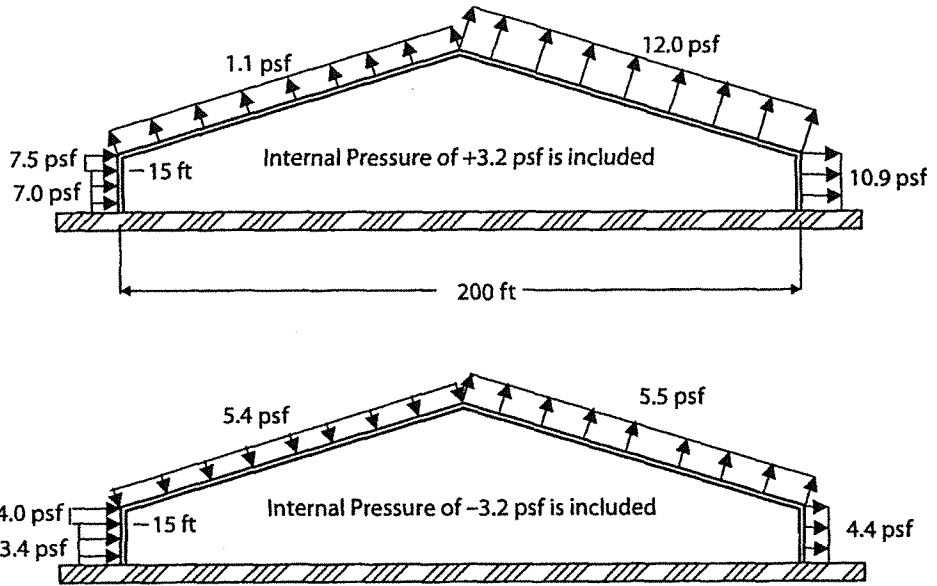
Surface	z (ft)	q (psf)	G	C <sub>p</sub>	Net pressure psf with	
					(+GC <sub>pi</sub> )	(-GC <sub>pi</sub> )
Windward wall	0–15	15.0	0.85	0.8	7.0	13.4
	20	15.8	0.85	0.8	7.5	14.0
Leeward wall	All	18.0	0.85	-0.5	-10.9	-4.4
Side walls	All	18.0	0.85	-0.7	-14.0	-7.5
Windward Roof*	-	18.0	0.85	-0.36	-8.8	-2.3
Leeward roof	-	18.0	0.85	-0.57	-12.0	-5.5

$q_h = 18.0$  psf;  $(GC_{pi}) = \pm 0.18$ ;  $q_h(GC_{pi}) = \pm 3.2$  psf.

\*Two loadings on windward roof and two internal pressures yield a total of four loading cases (see Figures 3-14 and 3-15).



**Figure 3-14** Net Design Wind Pressures for MWFRS when Wind is Normal to Ridge with Negative Windward External Roof Pressure Coefficient



**Figure 3-15** Net Design Wind Pressures for MWFRS when Wind is Normal to Ridge with Positive Windward External Roof Pressure Coefficient

External Roof  $C_p$  from Figure 6-6 for Wind Parallel to Ridge

For wind parallel to the ridge,  $h/L = 36.7/250 = 0.147$  and  $\theta < 10^\circ$ . The values of  $C_p$  for wind parallel to ridge are obtained from Figure 6-6 of the Standard and are shown in Tables 3-21 and 3-22.

Design Wind Load Cases

Section 6.5.12.3 of the Standard requires that any building whose wind loads have been determined under the provisions of Sections 6.5.12.2.1 and 6.5.12.2.3 shall be designed for wind load cases as defined in Figure 6-9 of the Standard. Case 1 includes the loadings shown in Figures 3-14 through 3-17. A combination of windward ( $P_W$ ) and leeward ( $P_L$ ) loads is applied for Load Cases 2, 3, and 4 as shown in Figure 6-9 of the Standard. Section 6.5.12.3 of the Standard has exception that if a building is designed with flexible diaphragm, only Load Cases 1 and 3 need to be considered. There is not enough structural information given in this example to assess flexibility of roof diaphragm. Structural designer will have to make judgment in each building.

Design Pressures for C&C (Section 6.5.12.4)

Eq. 6-22 of the Standard is used to obtain the design pressures for components and cladding:

$$p = q_h [(GC_p) - (GC_{pi})] \quad (\text{Eq. 6-22})$$

where

- $q_h = 18.0$  psf
- $(GC_p) =$  Values obtained from Figure 6-11
- $(GC_{pi}) = \pm 0.18$  for this building

Wall C&C Pressures

The pressure coefficients ( $GC_p$ ) (Table 3-23) are a function of effective wind area. The definition of effective wind area for a component or clad-

**Table 3-21** Roof  $C_p$  (Wind Parallel to Ridge)

Surface	$h/L$	Distance from windward edge	$C_p$
Roof	$\leq 0.5$	0 to $h$	-0.9, -0.18*
		$h$ to $2h$	-0.5, -0.18*
		$> 2h$	-0.3, -0.18*

\*The values of smaller uplift pressures on the roof can become critical when wind load is combined with roof live load or snow load; load combinations are given in Sections 2.3 and 2.4 of the Standard. For brevity, loading for this value is not shown in this example.

**Table 3-22** MWFRS Pressures: Wind Parallel to Ridge

Surface	$z$ (ft)	$q$ (psf)	$G$	$C_p$	Net pressure psf with	
					$(+GC_{pi})$	$(-GC_{pi})$
Windward wall	0-15	15.0	0.85	0.8	7.0	13.4
	20	15.8	0.85	0.8	7.5	14.0
	30	17.3	0.85	0.8	8.5	15.0
	40	18.3	0.85	0.8	9.2	15.7
	53.3	19.4	0.85	0.8	10.0	16.4
Leeward wall	All	18.0	0.85	-0.45	-10.1	-3.7
Side walls	All	18.0	0.85	-0.7	-14.0	-7.5
Roof*	0 to $h^*$	18.0	0.85	-0.9	-17.0	-10.5
	$h$ to $2h^*$	18.0	0.85	-0.5	-10.9	-4.4
	$> 2h^*$	18.0	0.85	-0.3	-7.8	-1.4

$q_h = 18.0$  psf;  $(GC_{pi}) = \pm 0.18$ ;  $h = 36.7$  ft;  $q_h(GC_{pi}) = \pm 3.2$  psf.

\*Distance from windward edge.

ding panel is the span length multiplied by an effective width that need not be less than one-third the span length; however, for a fastener it is the area tributary to an individual fastener.

Girt:

larger of

$$A = 25(6.67) = 167 \text{ ft}^2$$

or

$$A = 25(25/3) = 208 \text{ ft}^2 \text{ (controls)}$$

Wall Panel:

larger of

$$A = 6.67(2) = 13.3 \text{ ft}^2$$

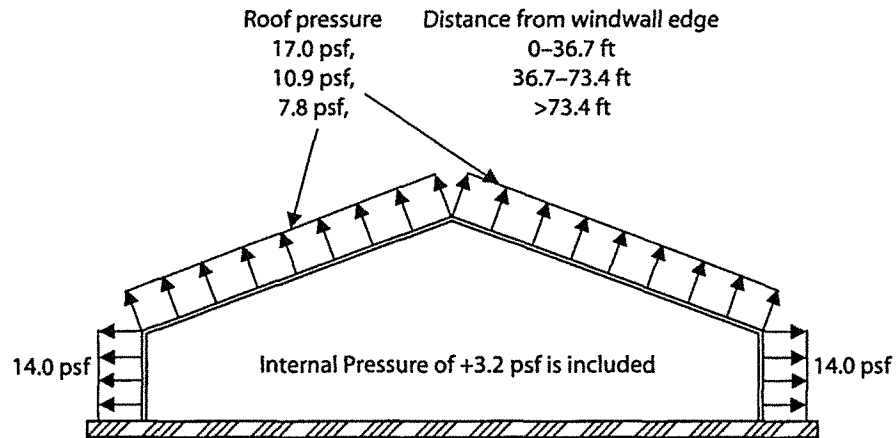
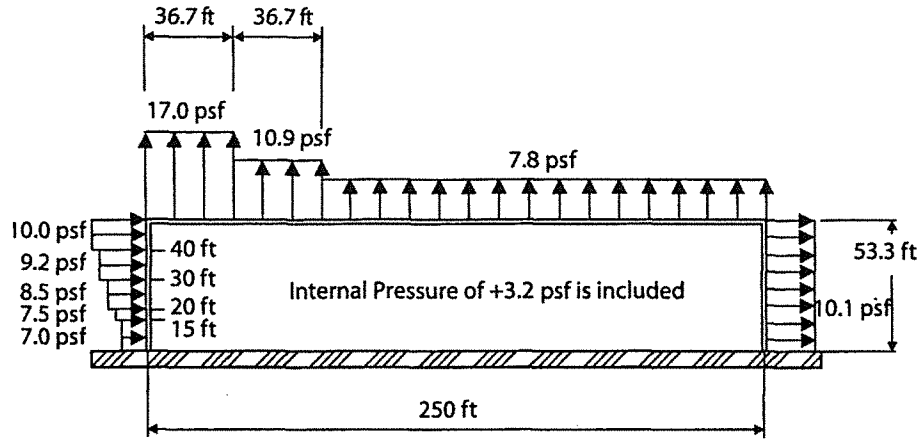
or

$$A = 6.67(6.67/3) = 14.8 \text{ ft}^2 \text{ (controls)}$$

Fastener:

$$A = 6.67(1) = 6.7 \text{ ft}^2$$

Typical calculations of design pressures for girt in Zone 4 are shown below and wall C&C pressures are summarized in Table 3-24:



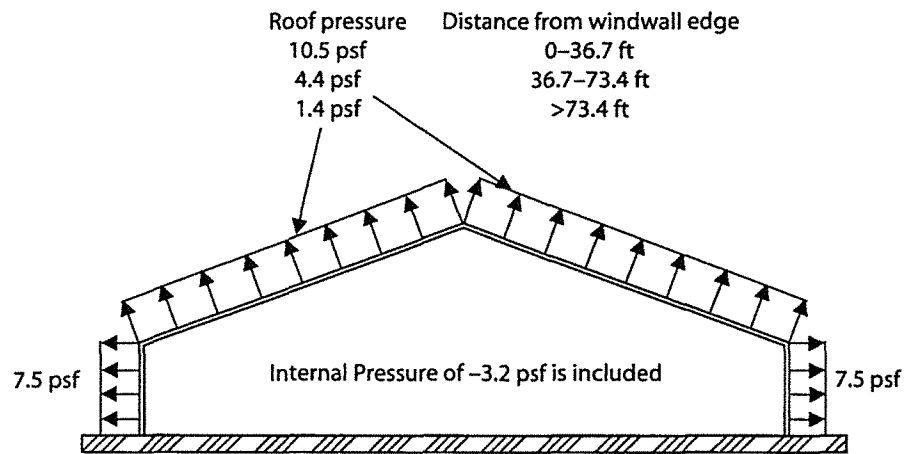
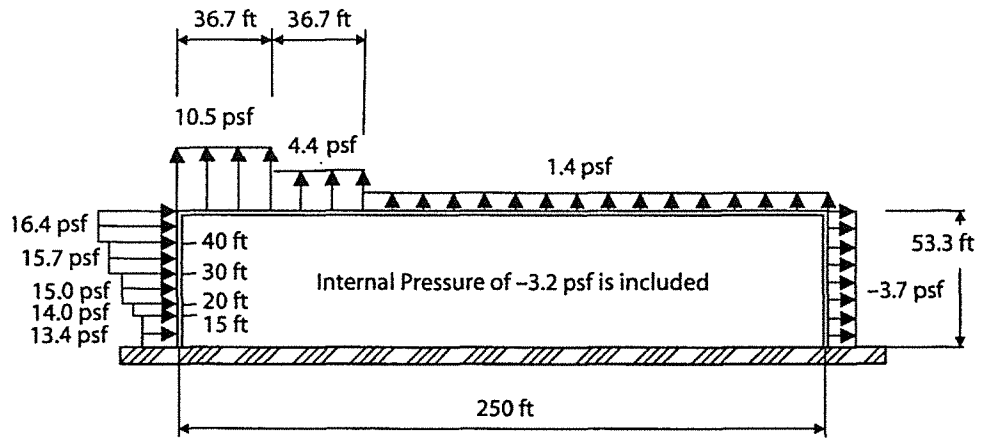
**Figure 3-16** Net Design Wind Pressures for MWFRS when Wind is Parallel to Ridge with Positive Internal Pressure

**Table 3-23** Wall Coefficients ( $GC_p$ ) in Figure 6-11A

C&C	A(ft <sup>2</sup> )	External ( $GC_p$ )		
		Zones 4 and 5	Zone 4	Zone 5
Girt	208	0.77*	-0.87	-0.93
Panel	14.8	0.97	-1.07	-1.34
Fastener	6.7	1.00	-1.10	-1.40
Other**	≤ 10	1.00	-1.10	-1.40
Other**	≥ 500	0.70	-0.80	-0.80

\*( $GC_p$ ) values are obtained using equations in Chapter 2 of this guide.

\*\*Other C&C can be doors, windows, etc.



**Figure 3-17** Net Design Wind Pressures for MWFRS when Wind is Parallel to Ridge with Negative Internal Pressure

**Table 3-24** Net Controlling Wall Component Pressures (psf)

C&C	Controlling design pressures (psf)			
	Zone 4		Zone 5	
	Positive	Negative	Positive	Negative
Girt	17.1	-18.9	17.1	-20.0
Panel	20.7	-22.5	20.7	-27.4
Fastener	21.2	-23.0	21.2	-28.4
$A \leq 10 \text{ ft}^2$	21.2	-23.0	21.2	-28.4
$A \geq 500 \text{ ft}^2$	15.8	-17.6	15.8	-17.6

For maximum negative pressure:

$$p = 18.0[(-0.87) - (\pm 0.18)]$$

$p = -18.9$  psf with positive internal pressure (controls)

$p = -12.4$  psf with negative internal pressure

For maximum positive pressure:

$$p = 18.0[(0.77) - (\pm 0.18)]$$

$p = 10.6$  psf with positive internal pressure

$p = 17.1$  psf with negative internal pressure (controls)

### Roof C&C Pressures

Effective wind areas of roof C&C (Table 3-25):

Purlin:

larger of

$$A = 25(5) = 125 \text{ ft}^2$$

or

$$A = 25(25/3) = 208 \text{ ft}^2(\text{controls})$$

Panel:

larger of

$$A = 5(2) = 10 \text{ ft}^2(\text{controls})$$

or

$$A = 5(5/3) = 8.3 \text{ ft}^2$$

Fastener:

$$A = 5(1) = 5 \text{ ft}^2$$

Typical calculations of design pressures for purlin in Zone 1 are as follows and roof C&C pressures are summarized in Table 3-26:

For maximum negative pressure:

$$p = 18.0[(-0.8) - (\pm 0.18)]$$

$p = -17.6$  psf with positive internal pressure (controls)

$p = -11.2$  psf with negative internal pressure

**Table 3-25** Roof Coefficients ( $GC_p$ ) in Figure 6-11C;  $7^\circ < \theta \leq 27^\circ$

Component	A (ft <sup>2</sup> )	External ( $GC_p$ )			
		Zones 1, 2, and 3	Zone 1	Zone 2	Zone 3
Purlin	208	0.3	-0.8	-1.2	-2.0
Panel	10	0.5	-0.9	-1.7	-2.6
Fastener	5	0.5	-0.9	-1.7	-2.6
Other*	≤10	0.5	-0.9	-1.7	-2.6
Other*	≥100	0.3	-0.8	-1.2	-2.0

\*Other C&C can be skylight, etc.

**Table 3-26** Net Controlling Roof Component Pressures (psf)

Component	Controlling design pressures (psf)			
	Positive	Negative		
	Zones 1, 2, and 3	Zone 1	Zone 2	Zone 3
Purlin	10.0*	-17.6	-24.8	-39.2
Panel	12.2	-19.4	-33.8	-50.0
Fastener	12.2	-19.4	-33.8	-50.0
$A \leq 10 \text{ ft}^2$	12.2	-19.4	-33.8	-50.0
$A \geq 500 \text{ ft}^2$	10.0*	-17.6	-24.8	-39.2

\*Minimum net pressure controls (Section 6.1.4.2 of the Standard).

For maximum positive pressure:

$$p = 18.0[(0.3) - (\pm 0.18)]$$

$p = 2.1$  psf with positive internal pressure

$p = 8.6$  psf with negative internal pressure

$p = 10$  psf minimum net pressure (controls)  
(Section 6.1.4.2 of the Standard)

Special case of girt that transverses Zones 4 and 5:

Width of Zone 5:

smaller of

$$a = 0.1(200) = 20 \text{ ft}$$

or

$$a = 0.4(36.7) = 14.7 \text{ ft (controls)}$$

but not less than

$$0.04(200) = 8 \text{ ft}$$

or 3 ft

Weighted average design pressure:

$$P = \frac{14.7(-20.0) + 10.3(-18.9)}{25} = -19.6 \text{ psf}$$

This procedure of using a weighted average may be used for other components and cladding.

### Special Case of Strut Purlin (interior)

Strut purlins in the end bay experience combined uplift pressure as a roof component (C&C) and axial load as part of the MWFRS

Component Pressure

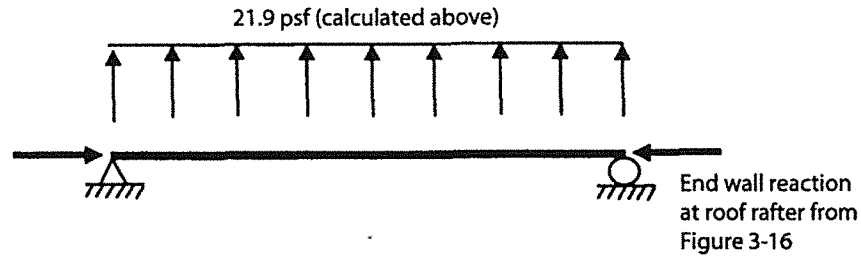
End bay purlin located in Zones 1 and 2

Width of Zone 2,  $a = 14.7$  ft

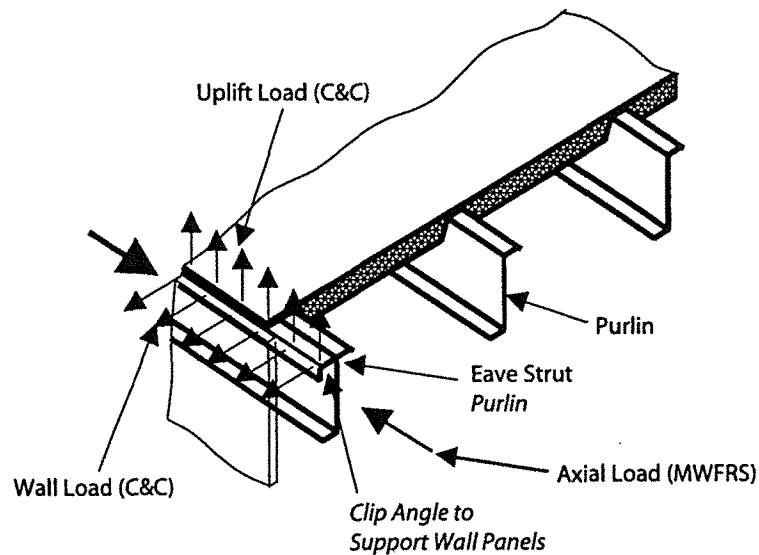
Weighted average design pressure:

$$= \frac{14.7(-24.8) + 10.3(-17.6)}{25} = -21.9 \text{ psf}$$

(Purlin in Zones 2 and 3 will have higher pressure)



**Figure 3-18A** Combined Uplift and Axial Design Loads on Interior Strut Purlin



**Figure 3-18B** Eave Strut Purlin Supports Roof and Wall Panels

#### MWFRS Load

Figure 3-16 shows design pressure on end wall with wind parallel to ridge with positive internal pressure (consistent with high uplift on the purlin). Assuming that the end wall is supported at the bottom and at the roof line, the effective axial load on an end bay purlin can be determined.

#### Combined Design Loads on Interior Strut Purlin

Figure 3-18A shows combined design load on interior strut purlin. Note that many metal building manufacturers support the top of the wall panels with the eave strut purlin (see Figure 3-18B). For this case, the eave purlin also serves as a girt, and the negative wall pressures of Zones 5 and 4 would occur for the same wind direction as the maximum negative uplift pressures on the purlin (refer to Zones 3 and 2). Thus, in this instance, the correct load combination would involve biaxial bending loads based on C&C pressures combined with the MWFRS axial load.

### 3.7 Example 7 Building of Ex. 6 Using Low-Rise Building Provisions

This example illustrates the use of the low-rise building provisions to determine design pressures for the MWFRS. For this purpose, the building used has the same dimensions as the building in Ex. 6 (Section 3.6 of this guide). The design pressures on C&C will be the same as Ex. 6. The building is shown in Figure 3-13. The building data are as follows:

---

<i>Location:</i>	Memphis, Tennessee
<i>Terrain:</i>	Flat farmland
<i>Dimensions:</i>	200 ft × 250 ft in plan Eave height of 20 ft Roof slope 4:12 (18.4°)
<i>Framing:</i>	Rigid frame spans the 200-ft direction Rigid frame bay spacing is 25 ft Lateral bracing in the 250-ft direction is provided by a "wind truss" spanning the 200 ft to side walls and cable/rod bracing in the planes of the walls Openings uniformly distributed

---

#### Low-Rise Building

Section 6.2 of the Standard specifies two requirements for a building to qualify as a low-rise building: (1) mean roof height has to be less than or equal to 60 ft, and (2) mean roof height does not exceed least horizontal dimension. A building with these dimensions qualifies as a low-rise building and the alternate provisions of Section 6.5.12.2.2 may be used.

#### Exposure, Building Classification, and Basic Wind Speed

Same as Ex. 6:  
Exposure C  
Category II  
Enclosed building (openings uniformly distributed)  
 $V = 90$  mph

#### Velocity Pressure

The low-rise building provisions for MWFRS in the Standard use the velocity pressure at mean roof height,  $h$ , for calculation of all external and internal pressures, including the windward wall. All pressures for a given zone are assumed to be uniformly distributed with respect to height above ground.

Mean roof height  $h = 36.7$  ft

The velocity pressures are computed using:

$$q_h = 0.00256 K_h K_{zt} K_d V^2 I \text{ (psf)} \quad \text{(Eq. 6-15)}$$

where

- $q_h$  = Velocity pressure at mean roof height,  $h$
- $K_h$  = 1.02 for Exposure C (see Table 6-3 of the Standard)
- $K_{zt}$  = 1.0 topographic factor (see Section 6.5.7.1)
- $K_d$  = 0.85 (see Table 6-4)

$$V = 90 \text{ mph basic wind speed (see Figure 6-1)}$$

$$I = 1.0 \text{ for Category II (50-yr mean return interval)}$$

Therefore:

$$q_h = 0.00256(1.02)(1.0)(0.85)(90)^2(1.0) = 18.0 \text{ psf}$$

## Design Pressures for the MWFRS

The equation for the determination of design wind pressures for MWFRS for low-rise buildings is given by Eq. 6-18 in Section 6.5.12.2.2 of the Standard:

$$p = q_h[(GC_{pf}) - (GC_{pi})] \quad (\text{Eq. 6-18})$$

where

- $q_h$  = The velocity pressure at mean roof height associated with Exposure C
- $(GC_{pf})$  = The external pressure coefficients from Figure 6-10 of the Standard
- $(GC_{pi})$  = The internal pressure coefficients from Figure 6-5 of the Standard

The building must be designed for all wind directions using the eight loading patterns shown in Figure 6-10 of the Standard. For each of these patterns, both positive and negative internal pressures must be considered, resulting in a total of 16 separate loading conditions. However, if the building is symmetrical, the number of separate loading conditions will be reduced to eight (two directions of MWFRS being designed for normal load and torsional load cases—a total of four load cases, one windward corner, and two internal pressures). The load patterns are applied to each building corner in turn as the reference corner.

## External Pressure Coefficients ( $GC_{pf}$ )

The roof and wall coefficients are functions of the roof slope,  $\theta$  (see Tables 3-27 and 3-28).

Width of end zone surface:

smaller of

$$2a = 2(0.1)(200) = 40 \text{ ft}$$

or

$$2(0.4)(36.7) = 29.4 \text{ ft (controls)}$$

but not less than

$$2(0.04)(200) = 16 \text{ ft}$$

or  $2(3) = 6 \text{ ft}$

## Internal Pressure Coefficients ( $GC_{pi}$ )

Openings are assumed to be evenly distributed in the walls, and since Memphis, Tennessee, is not located in a hurricane-prone region, the building qualifies as an enclosed building (see Section 6.2 of the Standard). The internal pressure coefficients are given from Figure 6-5 as  $(GC_{pi}) = \pm 0.18$ .

## Design Wind Pressures (psf)

Design wind pressures in the transverse and longitudinal directions are shown in Tables 3-29 and 3-30.

**Table 3-27** Transverse Direction ( $\theta = 18.4^\circ$ )

$GC_{pf}^*$	Building surface									
	1	2	3	4	5	6	1E	2E	3E	4E
	0.52	-0.69	-0.47	-0.42	-0.45	-0.45	0.78	-1.07	-0.67	-0.62

\*By linear interpolation.

**Table 3-28** Longitudinal Direction ( $\theta = 0^\circ$ )

$GC_{pf}$	Building surface									
	1	2	3	4	5	6	1E	2E	3E	4E
	0.40	-0.69	-0.37	-0.29	-0.45	-0.45	0.61	-1.07	-0.53	-0.43

**Table 3-29** Design Wind Pressures, Transverse Direction

Building surface	$(GC_{pf})$	Design pressure (psf)	
		$(+GC_{pi})$	$(-GC_{pi})$
1	0.52	6.1	12.6
2	-0.69	-15.6	-9.2
3	-0.47	-11.7	-5.2
4	-0.42	-10.8	-4.3
5	-0.45	-11.3	-4.9
6	-0.45	-11.3	-4.9
1E	-0.78	10.8	17.3
2E	-1.07	-22.5	-16.0
3E	-0.67	-15.3	-8.8
4E	-0.62	-14.4	-7.9

**Table 3-30** Design Wind Pressures, Longitudinal Direction

Building surface	$(GC_{pf})$	Design pressure (psf)	
		$(+GC_{pi})$	$(-GC_{pi})$
1	0.40	4.0	10.5
2	-0.69	-15.6	-9.2
3	-0.37	-9.9	-3.4
4	-0.29	-8.5	-2.0
5	-0.45	-11.3	-4.9
6	-0.45	-11.3	-4.9
1E	0.61	7.7	14.2
2E	-1.07	-22.5	-16.0
3E	-0.53	-12.8	-6.3
4E	-0.43	-11.0	-4.5

Calculation for Surface 1:

$$p = 18.0 [0.52 - (\pm 0.18)] = +6.1 \text{ or } +12.6$$

Application of Pressures on Building Surfaces 2 and 3

Note 8 of Figure 6-10 of the Standard states that when the roof pressure coefficient,  $GC_{pf}$  is negative in Zone 2, it shall be applied in Zone 2 for a distance from the edge of the roof equal to 0.5 times the horizontal dimension of the building measured parallel to the direction of the MWFRS being designed or  $2.5h$ , whichever is less. The remainder of Zone 2 that extends to the ridge line shall use the pressure coefficient  $GC_{pf}$  for Zone 3. Thus, the distance from the edge of the roof is the smaller of:

$$0.5(200) = 100 \text{ ft for transverse direction}$$

$$0.5(250) = 125 \text{ ft for longitudinal direction}$$

or

$$(2.5)(36.7) = 92 \text{ ft for both directions (controls)}$$

Therefore, Zone 3 applies over a distance of  $105 - 92 = 13 \text{ ft}$  in what is normally considered to be Zone 2 (adjacent to ridge line) for transverse direction and  $125 - 92 = 33 \text{ ft}$  for longitudinal direction.

Loading Cases

Because the building is symmetrical, the four loading cases provide all the required combinations provided the design is accomplished by applying loads for each of the four corners. The load combinations illustrated in Figures 3-19 through 3-22 are to be used to design the rigid frames, the "wind truss" spanning across the building in the 200-ft direction, and the rod/cable bracing in the planes of the walls (see Figure 3-13) (Section 3.6 of this guide).

Torsional Load Cases

Since the mean roof height,  $h = 36.7 \text{ ft}$ , is greater than 30 ft and if the roof diaphragm is assumed to be rigid, torsional load cases need to be considered (see exception in Note 5 in Figure 6-10 of the Standard if building is designed with flexible diaphragm). Pressures in "T" zones are 25% of the

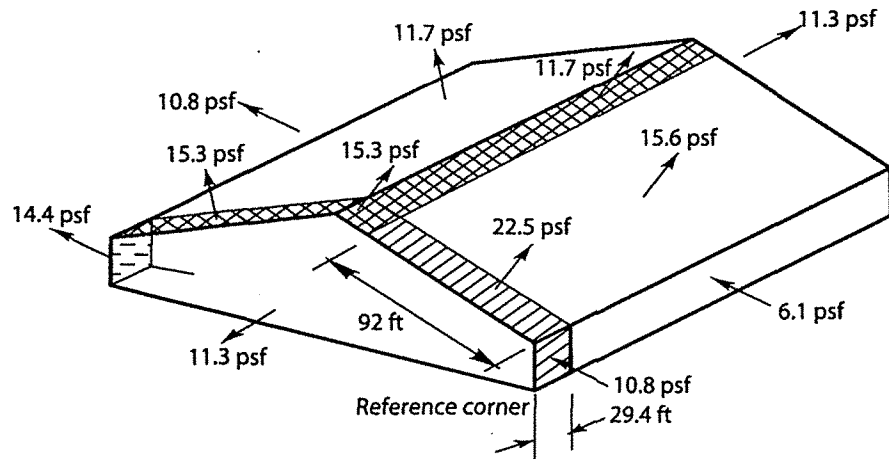
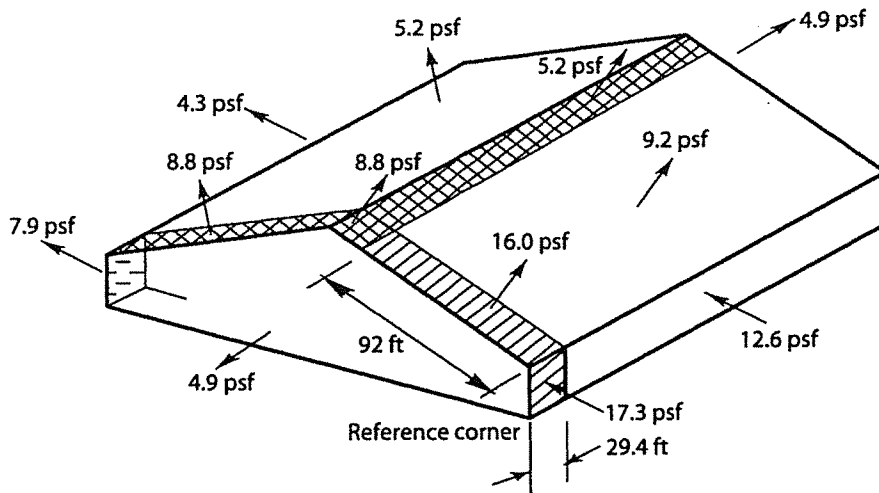
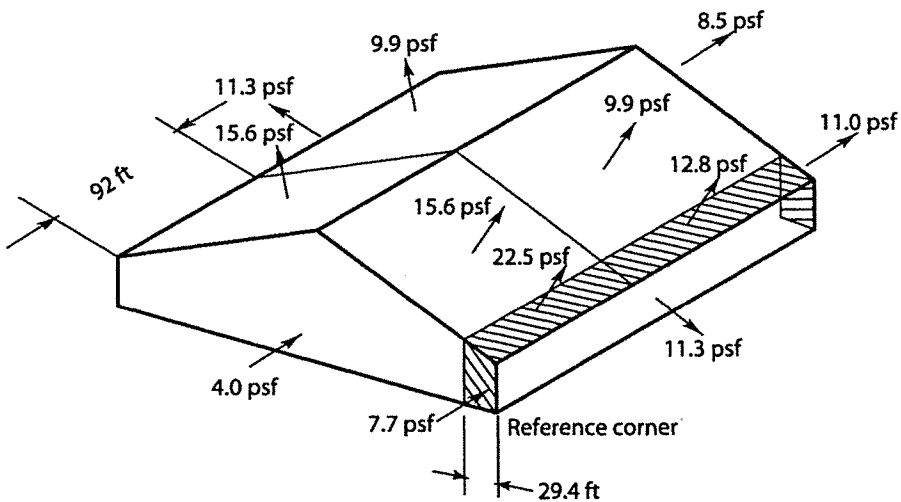


Figure 3-19 Design Pressures for Transverse Direction with Positive Internal Pressure

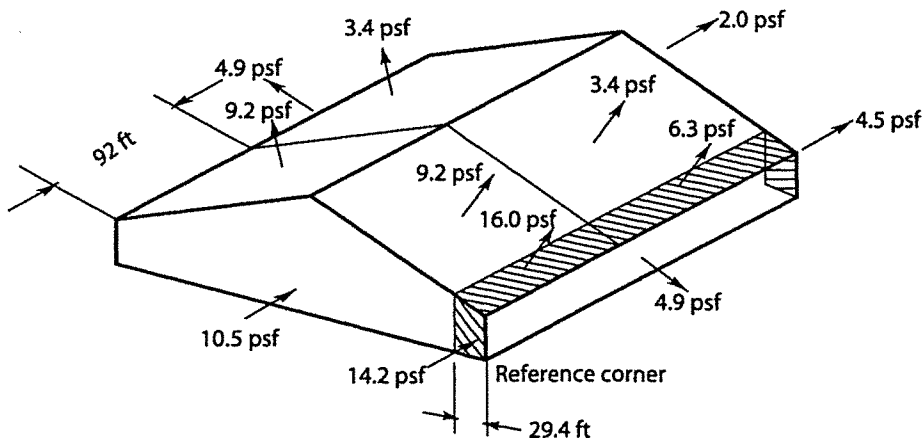
Note: The pressures are assumed to be uniformly distributed over each of the surfaces shown



**Figure 3-20** Design Pressures for Transverse Direction with Negative Internal Pressure  
 Note: The pressures are assumed to be uniformly distributed over each of the surfaces shown



**Figure 3-21** Design Pressures for Longitudinal Direction with Positive Internal Pressure  
 Note: The pressures are assumed to be uniformly distributed over each of the surfaces shown



**Figure 3-22** Design Pressures for Longitudinal Direction with Negative Internal Pressure  
 Note: The pressures are assumed to be uniformly distributed over each of the surfaces shown

**Table 3-31** Design Wind Pressure for Zone "T," Transverse Direction

Building surface	Design pressures (psf)	
	(+GC <sub>pi</sub> )	(-GC <sub>pi</sub> )
1T	1.5	3.2
2T	-3.9	-2.3
3T	-2.9	-1.3
4T	-2.7	-1.1

**Table 3-32** Design Wind Pressure for Zone "T," Longitudinal Direction

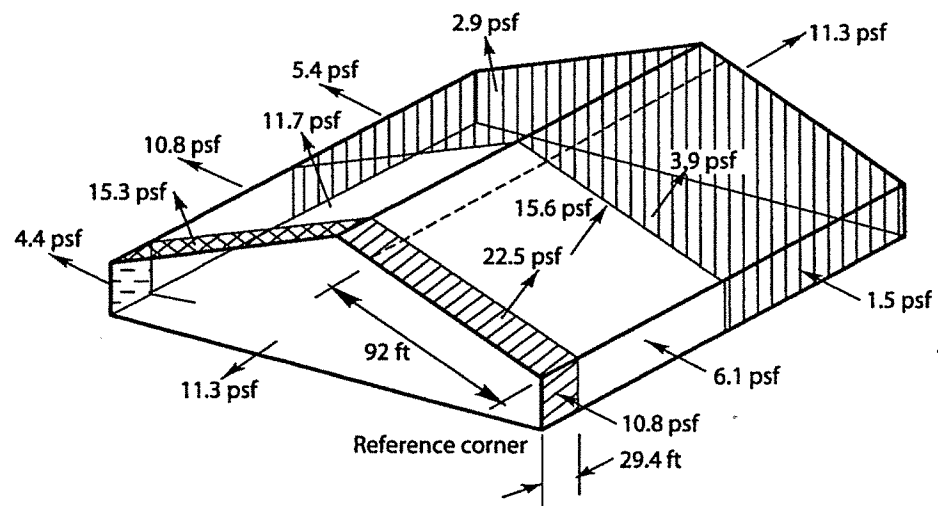
Building surface	Design pressures (psf)	
	(+GC <sub>pi</sub> )	(-GC <sub>pi</sub> )
1T	1.0	2.6
2T	-3.9	-2.3
3T	-2.5	-0.9
4T	-2.1	-0.5

full design pressures; the "T" zones are shown in Figure 6-10 of the Standard. Other surfaces will have the full design pressures. The "T" zone pressures with positive and negative internal pressures for transverse and longitudinal directions are shown in Tables 3-31 and 3-32, respectively.

Figures 3-19 through 3-26 show design pressure cases for one reference corner; these cases are to be considered for each corner.

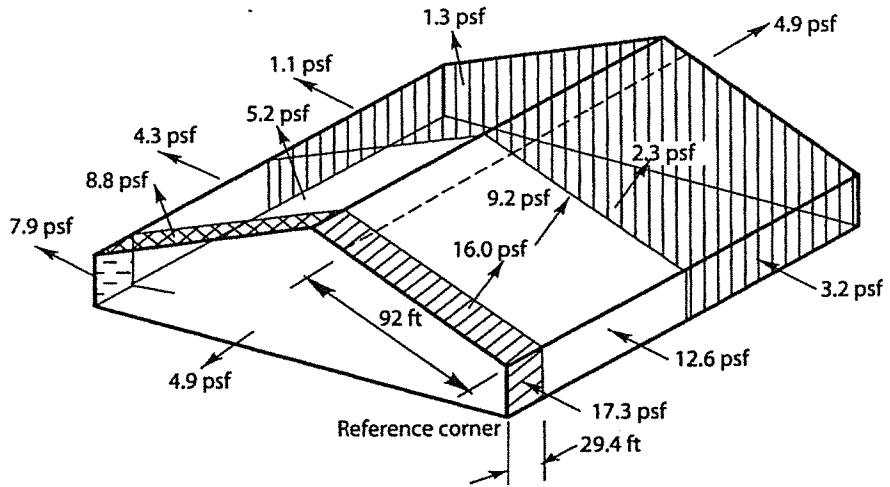
*Design Wind Pressures for C&C*

The design pressures for C&C are the same as shown for Ex. 6 (Section 3.6 of this guide).

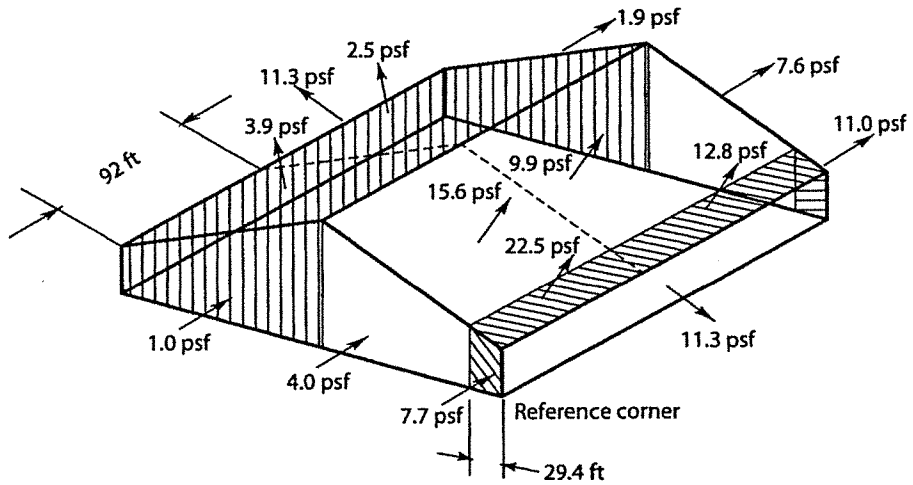


**Figure 3-23** Torsional Load Case for Transverse Direction with Positive Internal Pressure

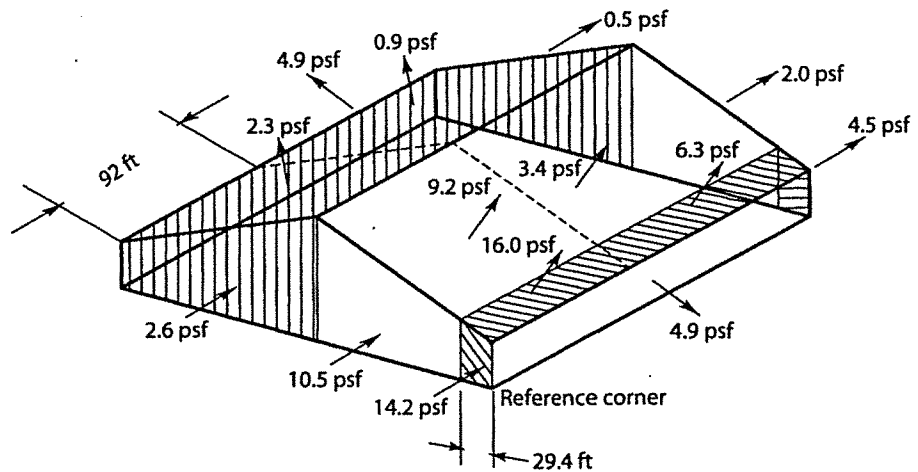
Notes: (1) The pressures are assumed to be uniformly distributed over each of the surfaces shown (2) Roof pressures of 22.5, 15.6, and 3.9 psf apply up to 92 ft; the remaining 13 ft up to the ridge line will have pressure of 15.3, 11.7, and 2.9 psf



**Figure 3-24** Torsional Load Case for Transverse Direction with Negative Internal Pressure  
 Notes: (1) The pressures are assumed to be uniformly distributed over each of the surfaces shown (2) Roof pressures of 16.0, 9.2, and 2.3 psf apply up to 92 ft; the remaining 13 ft up to the ridge line will have pressures of 8.8, 5.2, and 1.3 psf



**Figure 3-25** Torsional Load Case for Longitudinal Direction with Positive Internal Pressure  
 Note: The pressures are assumed to be uniformly distributed over each of the surfaces shown



**Figure 3-26** Torsional Load Case for Longitudinal Direction with Negative Internal Pressure  
 Note: The pressures are assumed to be uniformly distributed over each of the surfaces shown

### 3.8 Example 8 40-ft × 80-ft Commercial Building with Monoslope Roof with Overhang

In this example, design pressures for a typical retail store in a strip-mall are determined. The building's dimensions are shown in Figure 3-27. The building data are as follows:

<i>Location:</i>	Boston, Massachusetts, within 1 mi of the coastal mean high water-mark
<i>Topography:</i>	Homogeneous
<i>Terrain:</i>	Suburban
<i>Dimensions:</i>	40 ft × 80 ft in plan Monoslope roof with slope of 14° and overhang of 7 ft in plan Wall heights are 15 ft in front and 25 ft in rear
<i>Framing:</i>	Walls of CMU on all sides supported at top and bottom; steel framing in front (80-ft width) to support window glass and doors. Roof joists span 41.2 ft with 7.2-ft overhang spaced at 5 ft on center
<i>Cladding:</i>	Glass and door sizes vary; glazing is not debris-impact-resistant and occupies 50% of front wall (80 ft in width) Roof panels are 2 ft wide and 20 ft long

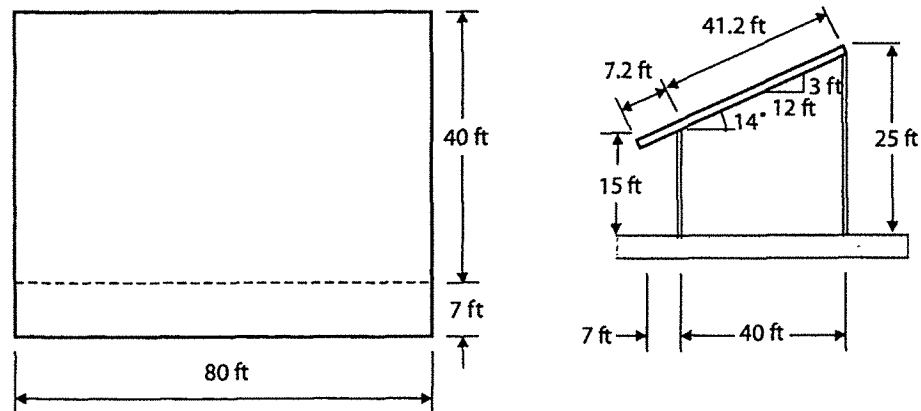
#### Building Classification, Enclosure Classification, and Exposure Category

The building is not an essential facility, nor is it likely to be occupied by more than 300 persons at any one time. Use Category II (see Table 1-1 of the Standard). Importance Factor  $I = 1.00$  (see Table 6-1 of the Standard).

The building is sited in a suburban area and satisfies the criteria for Exposure B (see Section 6.5.6 of the Standard).

The building is sited in a wind-borne debris region. It has glazing (not impact resistant) occupying 50% of a wall that receives positive pressure. The building must be classified as partially enclosed (see Sections 6.5.9.3 and 6.2 of the Standard).

The building does not meet the requirements of Method 1, Simplified Procedure (Section 6.4 of the Standard), because the roof slope is greater than 10°. Therefore, Method 2, Analytical Procedure, is used (see Section 6.5.3



**Figure 3-27** Dimensions of the Retail Store Strip-Mall

of the Standard). The roof is not gabled; hence, the low-rise building provisions may not be used.

The provisions of the Standard do not permit use of external pressure coefficients ( $GC_{pf}$ ) given in Figure 6-10. The values in Figure 6-10 were obtained from wind tunnel studies of rigid, gable-framed buildings. Their use for a monoslope roof requires considerable judgment. The design examples presented in Ex. 7 (Section 3.7 of this guide) illustrate use of the pressure coefficients of Figure 6-10, and the Commentary in the Standard gives the background for ( $GC_{pf}$ ) values.

### Basic Wind Speed

The wind speed contour of 110 mph traverses over Boston, Massachusetts (Figure 6-1c of the Standard); use a basic wind speed of 110 mph.

### Velocity Pressures

The velocity pressures (Table 3-33) are calculated using the following equation (see Section 6.5.10 of the Standard):

$$\begin{aligned} q &= 0.00256K_zK_{zt}K_dV^2I \text{ (psf)} && \text{(Eq. 6-15)} \\ &= 0.00256K_z(1.0)(0.85)(110)^2(1.0) \\ &= 26.33K_z \text{ (psf)} \end{aligned}$$

where

- $K_z$  = Value obtained from Table 6-3 of the Standard
- $K_{zt}$  = 1.0 homogeneous terrain
- $I$  = 1.0 for Category II building (see Table 6-1)
- $K_d$  = 0.85, see Table 6-4

The provisions of the Standard require the use of the external pressure coefficients,  $C_p$ , from Figure 6-6; hence, the exposure coefficients,  $K_z$ , are based on Exposure B, Case 2, for MWFRS and Exposure B; Case 1, for C&C (see Table 6-3).

### Design Pressures for MWFRS

The equation for rigid buildings of all heights is given in Section 6.5.12.2 of the Standard as follows:

$$p = qGC_p - q_i(GC_{pi}) \quad \text{(Eq. 6-17)}$$

where

- $q$  =  $q_z$  for windward wall
- $q_i$  =  $q_h$  for windward and leeward walls, side walls and roof

**Table 3-33** Velocity Pressures,  $q_z$ ,  $q_i$ , and  $q_h$  (psf)

Height (ft)	MWFRS		C&C	
	Exposure B, Case 2	$q_z$ , $q_i$	Exposure B, Case 1	$q_h$
0-15	0.57	15.01		
$h = 20$	0.62	16.32*	0.70	18.43
25	0.66	17.38		

\* $q_h = 16.32$  psf for MWFRS

- $G$  = Value determined from Section 6.5.8 of the Standard  
 $C_p$  = Value obtained from Figure 6-6 of the Standard  
 $(GC_{pi})$  = Value obtained from Figure 6-5 of the Standard

For positive internal pressure evaluation, the Standard permits  $q_i$  to be conservatively evaluated at height  $h$  ( $q_i = q_h$ ). Section 6.5.11.1.1 of the Standard permits the reduction of  $(GC_{pi})$  for a partially enclosed building containing a single, unpartitioned large volume by the following factor:

$$\begin{aligned}
 R_i &= 0.5 \left( 1 + \frac{1}{\sqrt{1 + \frac{V_i}{22,800 A_{og}}}} \right) \\
 &= 0.5 \left( 1 + \frac{1}{\sqrt{1 + \frac{80 \times 40 \times 20}{22,800 \times 50\% (15 \times 80)}}} \right) \cong 1 \quad \text{(no reduction)}
 \end{aligned}$$

where

- $V_i$  = Unpartitioned internal volume  
 $A_{og}$  = Total area of openings in building envelope (50% of front wall)

#### Gust Effect Factor, $G$

The gust effect factor for non-flexible (rigid) buildings is given in Section 6.5.8 of the Standard as  $G = 0.85$ .

The size of the building would not permit a reduction in  $G$  based on Eq. 6-4 of the Standard.

#### Wall External Pressure Coefficients ( $C_p$ ) (Table 3-34)

The coefficients for the windward and side walls are given in Figure 6-6 of the Standard as  $C_p = +0.8$  and  $-0.7$ , respectively. The values for the leeward wall depend on  $L/B$ ; they are different for the two directions: (1) wind parallel to roof slope (normal to ridge), and (2) wind normal to roof slope (parallel to ridge).

#### Roof External Pressure Coefficients ( $C_p$ ) (Table 3-35)

Since the building has a monoslope roof, the roof surface for wind directed parallel to the slope (normal to ridge) may be a windward or a leeward surface. The value of  $h/L = 0.5$  in this case, and the proper coefficients are obtained from linear interpolation for  $\theta = 14^\circ$ .

When wind is normal to the roof slope (parallel to ridge), angle  $\theta = 0$  and  $h/L = 0.25$ .

For the overhang, Section 6.5.11.4.1 of the Standard requires  $C_p = 0.8$  for wind directed normal to 15-ft wall. The Standard does not address the leeward overhang for the case of wind directed toward 25-ft wall and perpendicular to roof slope (parallel to ridge). A  $C_p = -0.5$  could be used (coefficient for leeward wall), but the coefficient has been conservatively taken as 0.

The building is sited in a hurricane-prone region less than 1 mi from the coastal mean high-water level. The basic wind speed is 110 mph and the glazing is not designed to resist wind-borne debris impact. Thus, as noted earlier, the building must be classified as partially enclosed, despite the

**Table 3-34** Wall Pressure Coefficients ( $C_p$ )

Surface	Wind direction	L/B	$C_p$
Leeward wall	to roof slope	0.5	-0.5
Leeward wall	⊥ to roof slope	2.0	-0.3
Windward wall	-	-	0.8
Side walls	-	-	-0.7

**Table 3-35** Roof Pressure Coefficients ( $C_p$ )

Wind direction	$h/L$	$\theta^\circ$	$C_p$
to roof slope	0.5	14	-0.74, -0.18** as windward slope
to roof slope	0.5	14	-0.50 as leeward slope
⊥ to roof slope	0.25	0	-0.90 (0-20 ft)* -0.18** (0-80 ft)* -0.50 (20-40 ft) -0.30 (40-80 ft)

\*Distance from the windward edge of the roof.

\*\*The values of smaller uplift pressures on the roof can become critical when wind load is combined with roof live load or snow load; load combinations are given in Sections 2.3 and 2.4 of the Standard. For brevity, loading for this value is not shown here.

openings in the walls and the roof. The internal pressure coefficients, from Figure 6-5 of the Standard are as follows:

$$(GC_{pi}) = +0.55$$

and

$$(GC_{pi}) = -0.55$$

*Typical Calculations of Design Pressures for MWFRS (Wind Parallel to Slope with 15-ft Windward Wall) (Table 3-36)*

Pressure on Leeward Wall

$$\begin{aligned} p &= q_h GC_p - q_h (\pm GC_{pi}) \\ &= 16.32(0.85)(-0.5) - (16.32)(+0.55) \\ &= -15.9 \text{ psf with positive internal pressure} \end{aligned}$$

and

$$\begin{aligned} &= 16.32(0.85)(-0.5) - (16.32)(-0.55) \\ &= 2.0 \text{ psf with negative internal pressure} \end{aligned}$$

Pressure on Overhang Top Surface

$$\begin{aligned} p &= q_h GC_p \\ &= 16.32(0.85)(-0.74) \\ &= -10.3 \text{ psf} \end{aligned}$$

**Table 3-36** Design Pressures for MWFRS: Wind Parallel to Roof Slope (normal to ridge line)

Wind direction	Surface	Z (ft)	$q_z$ (psf)	Gust effect	External $C_p^*$	Design pressure (psf)	
						(+GC <sub>pi</sub> )	(-GC <sub>pi</sub> )
Windward wall (15 ft)	Windward wall	0-15	15.01	0.85	0.80	1.2	19.2
	Leeward wall	0-25	16.32	0.85	-0.50	-15.9	2.0
	Side wall	All	16.32	0.85	-0.70	-18.7	-0.7
	Roof	-	16.32	0.85	-0.74	-19.2	-1.3
	Overhang top	-	16.32	0.85	-0.74	-10.3**	-10.3**
	Overhang bottom	-	15.01	0.85	0.80	10.2**	10.2**
Windward wall (25 ft)	Windward wall	0-15	15.01	0.85	0.80	1.2	19.2
		15-20	16.32	0.85	0.80	2.1	20.1
		20-25	17.38	0.85	0.80	2.8	20.8
	Leeward wall	All	16.32	0.85	-0.50	-15.9	2.0
	Side wall	All	16.32	0.85	-0.70	-18.7	-0.7
	Roof	-	16.32	0.85	-0.50	-15.9	2.0
	Overhang top	-	16.32	0.85	-0.50	-6.9**	-6.9**
	Overhang bottom	-	-	-	-	0.0**	0.0**

\*External pressure calculations include  $G = 0.85$ .

\*\*Overhang pressures are not affected by internal pressures. The Standard does not address bottom surface pressures for leeward overhang. It could be argued that leeward wall pressure coefficients can be applied, but note that neglecting the bottom overhang pressures would be conservative in this application.

Pressure on Overhang Bottom Surface (same as windward wall external pressure)

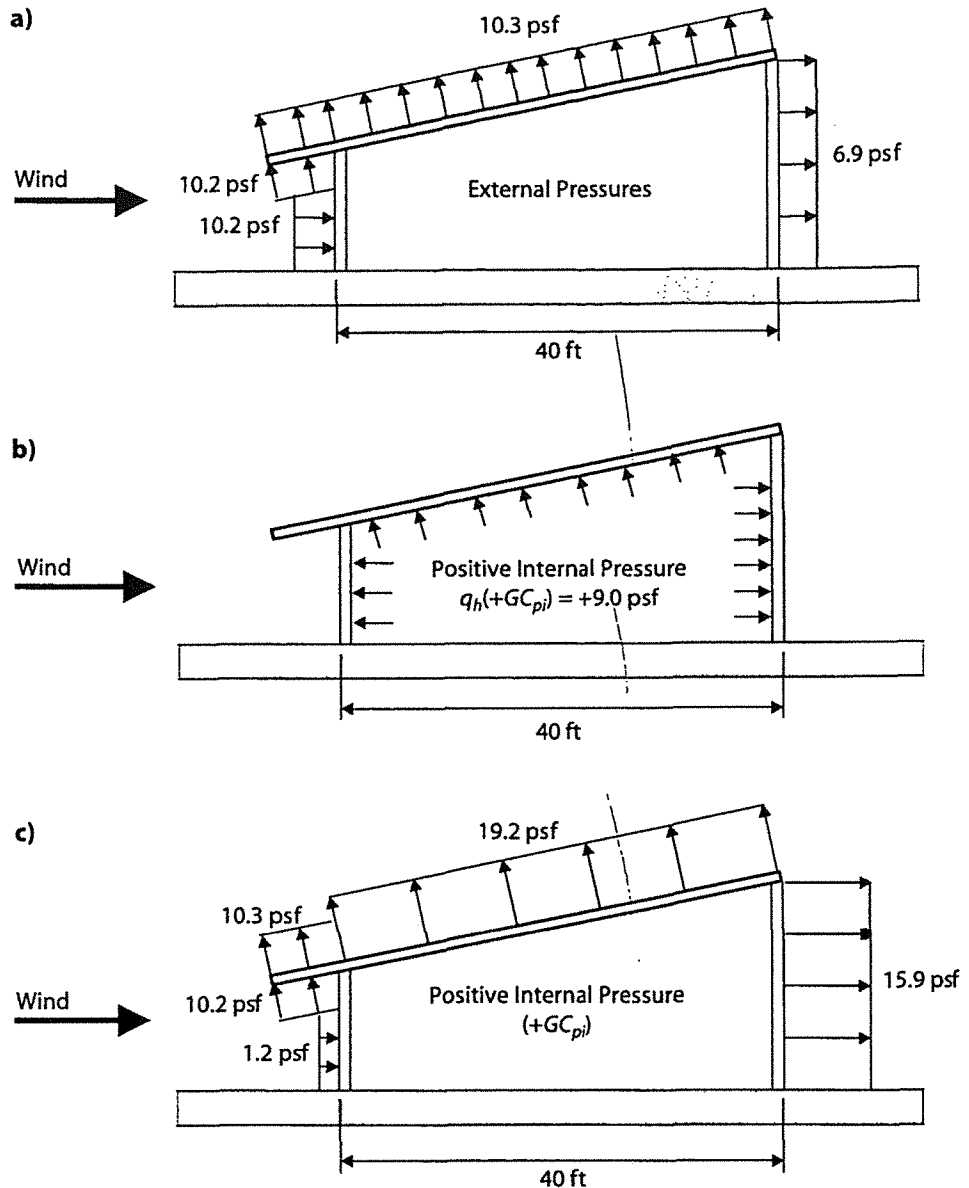
$$\begin{aligned}
 p &= q_z G C_p \\
 &= 15.01 (0.85) (0.8) \\
 &= 10.2 \text{ psf}
 \end{aligned}$$

Note that  $q_z$  was evaluated for  $z = 15$  ft for bottom surface of overhang as  $C_p$  coefficient is based on induced pressures at top of wall.

Figures 3-28 and 3-29 illustrate the external, internal, and combined pressure for wind directed normal to the 15-ft wall. Figures 3-30 and 3-31 illustrate combined pressure for wind directed normal to the 25-ft wall and perpendicular to slope (parallel to ridge line), respectively (Table 3-37).

**Design Wind Load Cases**

Section 6.5.12.3 of the Standard requires that any building whose wind loads have been determined under the provisions of Sections 6.5.12.2.1 and 6.5.12.2.3 shall be designed for wind load cases as defined in Figure 6-9 of the Standard. Case 1 includes the loadings shown in Figure 3-28 through Figure 3-31. The exception in Section 6.5.12.3 of the standard indicates that a combination of windward ( $P_W$ ) and leeward ( $P_L$ ) loads is applied for Load Cases 3 only since mean roof height  $h$  of the building is less than 30 ft.



**Figure 3-28** Design Pressures for MWRFS; Wind Parallel to Roof Slope, Normal to 15-ft Wall, and Positive Internal Pressure a., External Pressures; b., Positive Internal Pressure; c., Combined External and Positive Internal Pressure

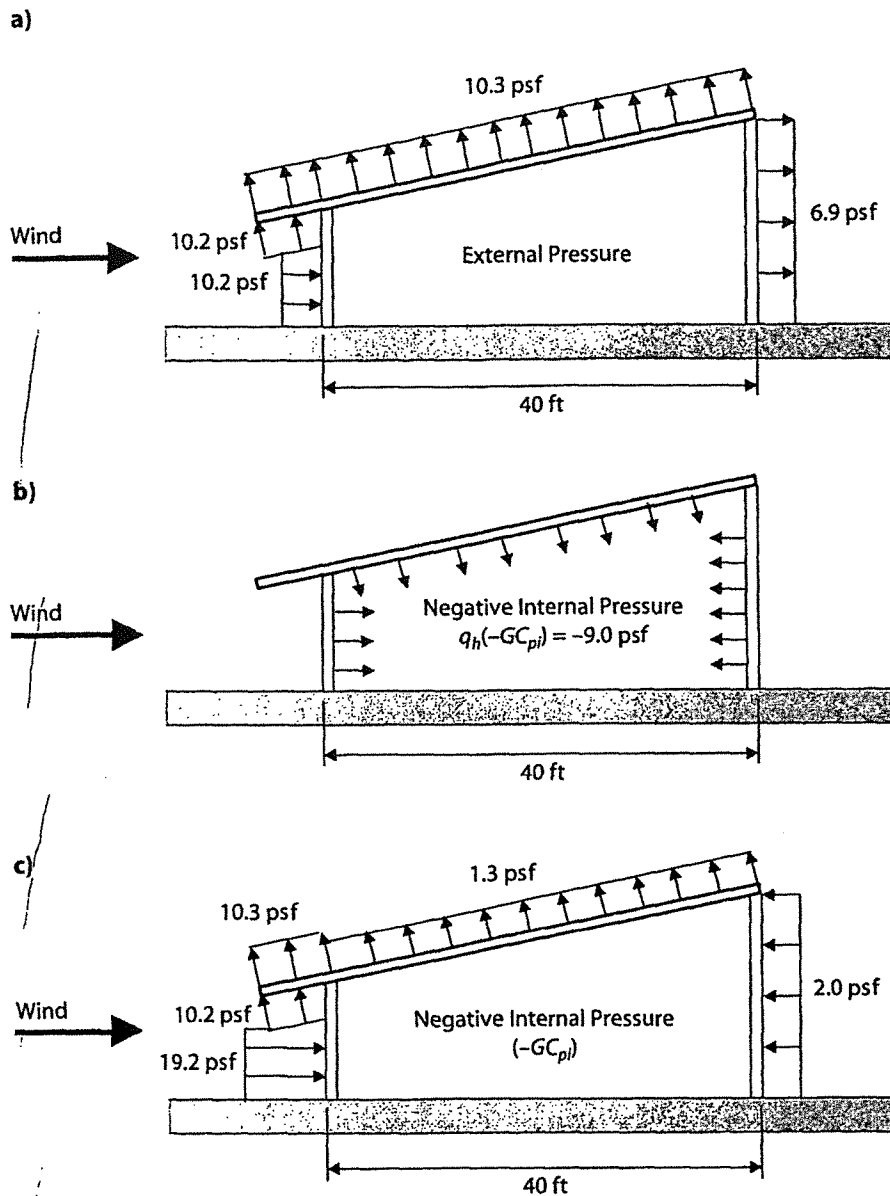
### Design Pressures for C&C

The design pressure equation for C&C for building with mean roof height  $h \leq 60$  ft is given in Section 6.5.12.4.1 of the Standard:

$$P = q_h [(GC_p) - (GC_{pi})] \quad (\text{Eq. 6-22})$$

where

- $q_h$  = Velocity pressure at mean roof height associated with Exposure B, Case 1 ( $q_h = 18.43$  psf, previously determined)
- $(GC_p)$  = External pressure coefficients from Figures 6-11A, 6-11C, and 6-14B of the Standard
- $(GC_{pi})$  =  $+0.55$  and  $-0.55$ , previously determined from Figure 6-5 of the Standard



**Figure 3-29** Design Pressures for MWRFS; Wind Parallel to Roof Slope, Normal to 15-ft Wall and Negative Internal Pressure a., External Pressures; b., Negative Internal Pressure; c., Combined External and Negative Internal Pressure

**Wall Design Pressures**  
(Table 3-38)

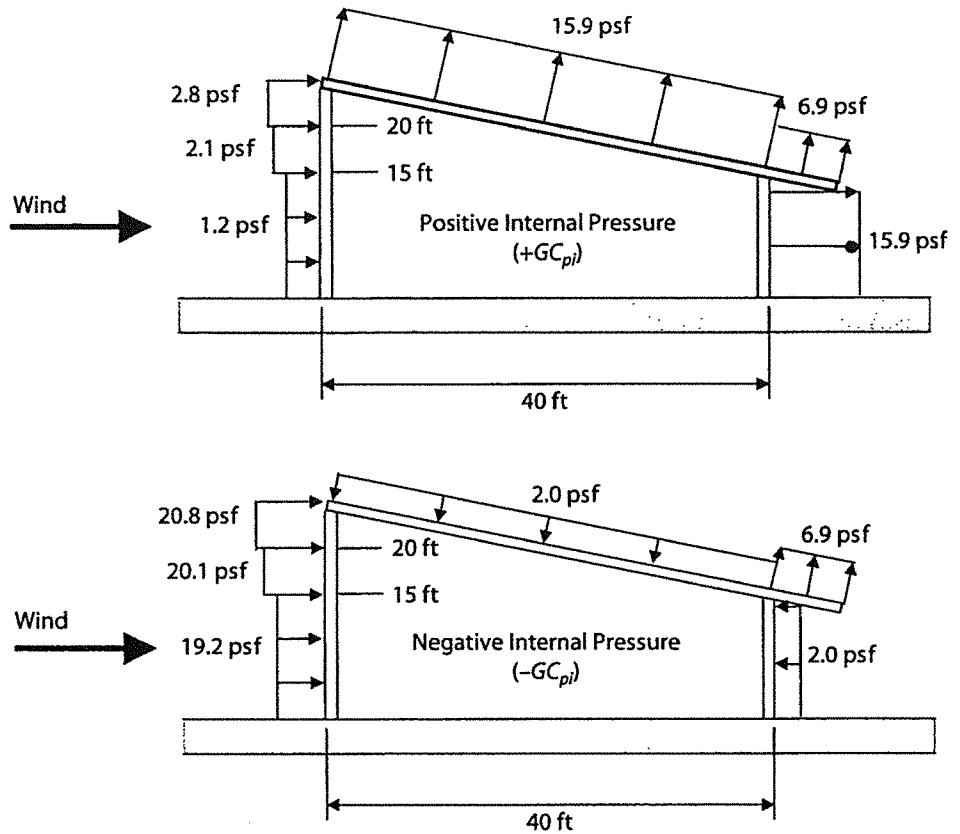
Since the CMU walls are supported at the top and bottom, the effective wind area will depend on the span length.

Effective wind area:

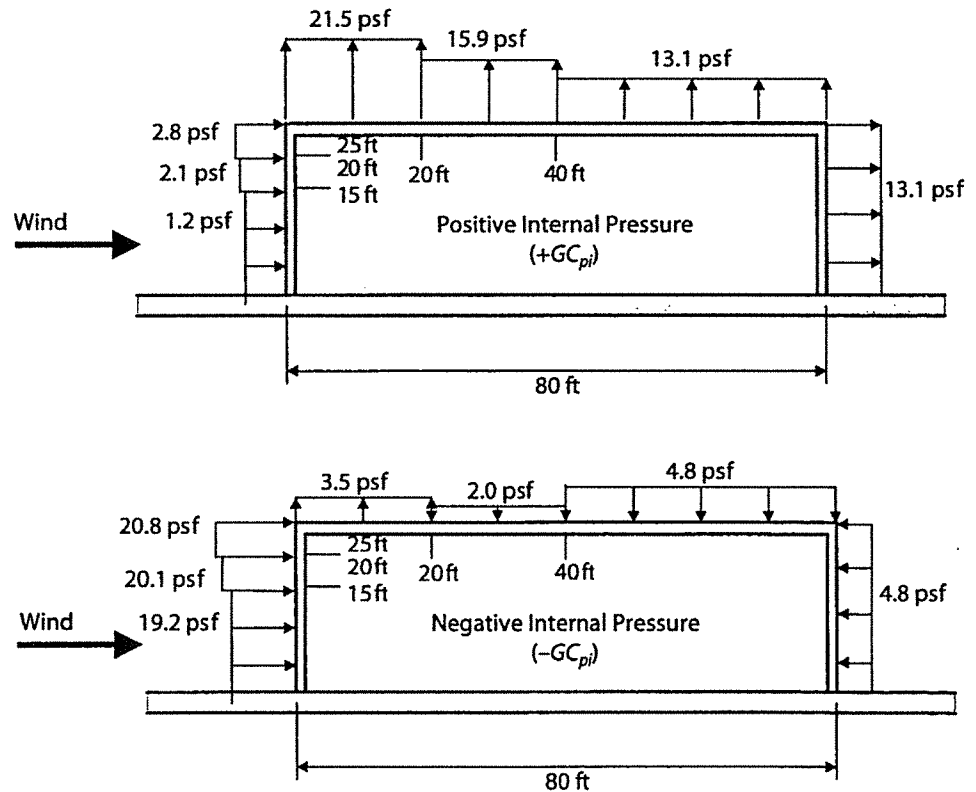
- For span of 15 ft,  $A = 15(15/3) = 75 \text{ ft}^2$
- For span of 20 ft,  $A = 20(20/3) = 133 \text{ ft}^2$
- For span of 25 ft,  $A = 25(25/3) = 208 \text{ ft}^2$

Width of Zone 5 (Figure 6-11A):

$$a \leq \begin{cases} 0.1(40) = 4 \text{ ft (controls)} \\ 0.4(20) = 8 \text{ ft} \end{cases}$$



**Figure 3-30** Combined Design Pressures for MWRFS; Wind Parallel to Roof Slope (Normal to 25-ft Wall)



**Figure 3-31** Combined Design Pressures for MWRFS; Wind Perpendicular to Roof Slope (Parallel to Ridge Line)

**Table 3-37** Design Pressures for MWFRS: Wind Normal to Roof Slope (parallel to ridge line)

Surface	z or Distance (ft)†	q <sub>z</sub> * (psf)	Gust effect, G	C <sub>p</sub>	Design pressure (psf)	
					+(GC <sub>pi</sub> )**	-(GC <sub>pi</sub> )**
Windward wall	0–15	15.01	0.85	0.8	1.2	19.2
	15–20	16.32	0.85	0.8	2.1	20.1
	20–25	17.38	0.85	0.8	2.8	20.8
Leeward wall	All	16.32	0.85	-0.3	-13.1	4.8
Side wall	All	16.32	0.85	-0.7	-18.7	-0.7
Roof‡	0–20	16.32	0.85	-0.9	-21.5	-3.5
	20–40	16.32	0.85	-0.5	-15.9	2.0
	40–80	16.32	0.85	-0.3	-13.1	4.8

\*External pressure calculations include  $G = 0.85$ .

\*\*Internal pressure is associated with  $q_h = 16.32$  psf.

†Distance along roof is from leading windward edge.

‡Pressure on overhang is only external pressure (contribution on underside is conservatively neglected).

**Table 3-38** Wall External Pressure Coefficients ( $GC_p$ )

A (ft <sup>2</sup> )	Pressure coefficients		
	Zones 4 and 5 (+GC <sub>p</sub> )	Zone 4 (-GC <sub>p</sub> )	Zone 5 (-GC <sub>p</sub> )
75	0.85	-0.95	-1.09
133	0.80	-0.90	-1.00
208	0.77	-0.87	-0.93

but not less than

$$a \geq \begin{cases} 0.4(40) = 1.6 \text{ ft} \\ 3 \text{ ft} \end{cases}$$

Design pressures are the critical combinations when the algebraic sum of the external and internal pressures is a maximum.

Typical Calculations for  
Design Pressures for  
15-ft Wall, Zone 4  
(Table 3-39)

$$\begin{aligned} p &= q_h[(GC_p) - (\pm GC_{pi})] \\ &= 18.43[(0.85) - (-0.55)] \\ &= 25.8 \text{ psf} \end{aligned}$$

and

$$\begin{aligned} &= 18.43[(-0.95) - (0.55)] \\ &= -27.6 \text{ psf} \end{aligned}$$

The CMU walls are designed for pressures determined for Zones 4 and 5 using appropriate tributary areas.

The design pressures for doors and glazing can be assessed by using appropriate pressure coefficients associated with their effective wind areas.

**Table 3-39** Wall Design Pressures (psf)

Wall height (ft)	Design pressures (psf)		
	Zones 4 and 5 Positive	Zone 4 Negative	Zone 5 Negative
15	25.8	-27.6	-30.2
20	24.9	-26.7	-28.6
25	24.3	-26.2	-27.3

Note:  $q_h = 18.43$  psf.

**Roof Design Pressures**  
(Tables 3-40 and 3-41)

Effective wind area:

Roof joist:

$$A = (41.2)(5) = 206 \text{ ft}^2$$

or

$$= (41.2)(41.2/3) = 566 \text{ ft}^2 \text{ (controls)}$$

Roof panel:

$$A = (5)(2) = 10 \text{ ft}^2 \text{ (controls)}$$

or

$$= (5)(5/3) = 8.3 \text{ ft}^2$$

Had the effective wind area of the roof joist been greater than 700 ft<sup>2</sup>, its external pressure coefficients ( $GC_p$ ) would still have been determined on the basis of components and cladding. The statement in Section 6.5.12.1.3 of the Standard, in which provisions for MWFRS may be used for a major component, is valid only when the tributary area is greater than 700 ft<sup>2</sup>. The tributary area for the roof joist is 242 ft<sup>2</sup>.

Section 6.5.11.4.2 of the Standard requires that pressure coefficients for components and cladding of roof overhangs be obtained from Figure 6-11C. Note that the zones for roof overhangs in Figure 6-11C are different from the zones for a monoslope roof in Figure 6-14B.

Width of zone distance  $a$ :

$$a \leq \begin{cases} 0.1(40) = 4 \text{ ft (controls)} \\ 0.4(20) = 8 \text{ ft} \end{cases}$$

but not less than

$$a \geq \begin{cases} 0.4(40) = 1.6 \text{ ft} \\ 3 \text{ ft} \end{cases}$$

The widths and lengths of Zones 2 and 3 for a monoslope roof are shown in Figure 6-14B of the Standard (they vary from  $a$  to  $4a$ ); for overhangs, widths and lengths are shown in Figure 6-11C.

Similar to the determination of design pressures for walls, the critical design pressures for roofs are the algebraic sum of the external and internal pressures. The design pressures for overhang areas are based on pressure coefficients obtained from Figure 6-11C of the Standard.

**Table 3-40** Roof External Pressure Coefficients ( $GC_p$ ),  $\theta = 14^\circ$ 

Component	A (ft <sup>2</sup> )	Pressure coefficient, Figure 6-14B			
		Zones 1, 2, and 3	Zone 1	Zone 2	Zone 3
		(+ $GC_p$ )	(- $GC_p$ )	(- $GC_p$ )	(- $GC_p$ )
Joist panel	566	0.3	-1.1	-1.2	-2.0
	10	0.4	-1.3	-1.6	-2.9

Component	A (ft <sup>2</sup> )	Pressure coefficient, Figure 6-11C			
		Zones 1, 2, and 3	Zone 1	Zone 2*	Zone 3*
		(+ $GC_p$ )	(- $GC_p$ )	(- $GC_p$ )	(- $GC_p$ )
Joist panel	566	0.3	-0.8	-2.2	-2.5
	10	0.5	-0.9	-2.2	-3.7

\* Values are from overhang chart in Figure 6-11C

**Table 3-41** Roof Design Pressures (psf)

Component	Design pressures (psf)			
	Zones 1, 2, and 3*	Zone 1	Zone 2	Zone 3
	Positive	Negative	Negative	Negative
Joist	15.7	-30.4	-32.2	-47.0
Joist overhang	10.0**	-14.7	-40.6	-46.1
Panel	17.5	-34.1	-39.6	-63.6
Panel in overhang	10.0**	-16.6	-40.6	-68.2

Notes:  $q_h = 18.43$  psf

\*Zones for overhang are in accordance with Figure 6-11C of the Standard.

\*\*Section 6.1.4.2 of the Standard requires minimum of 10 psf.

### Typical Calculations for Joist Pressures

Zone 2:

$$\begin{aligned}
 p &= q_h [(GC_p) - (\pm GC_{pi})] \\
 &= 18.43 [(0.3) - (-0.55)] \\
 &= 15.7 \text{ psf}
 \end{aligned}$$

and

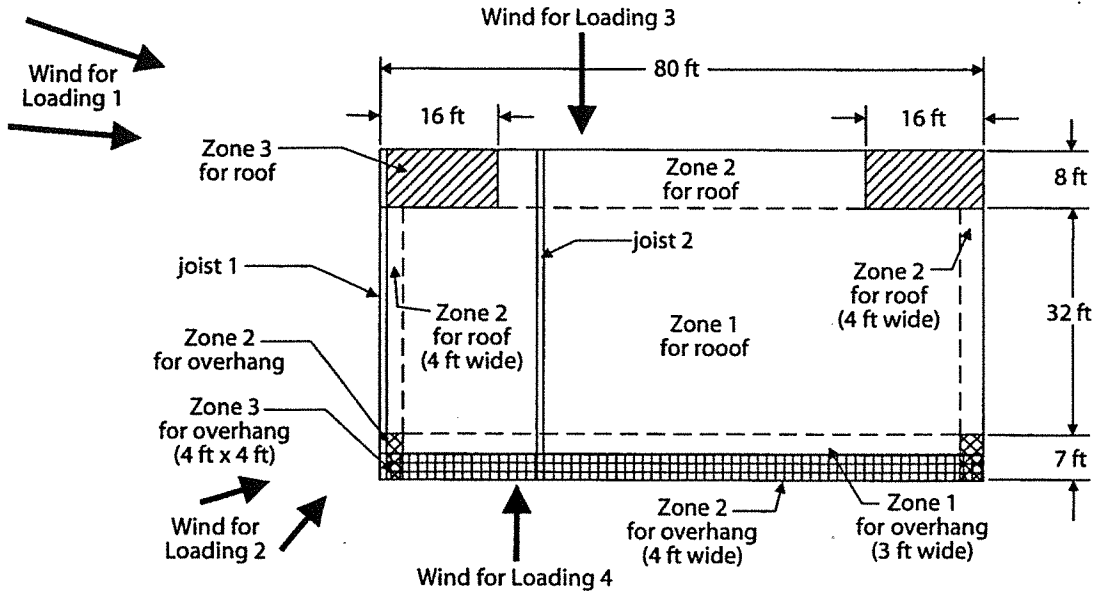
$$\begin{aligned}
 &= 18.43 [(-1.2) - (0.55)] \\
 &= -32.2 \text{ psf}
 \end{aligned}$$

Zones for the monoslope roof and for overhang are shown in Figure 3-32. The panels are designed for the pressures indicated.

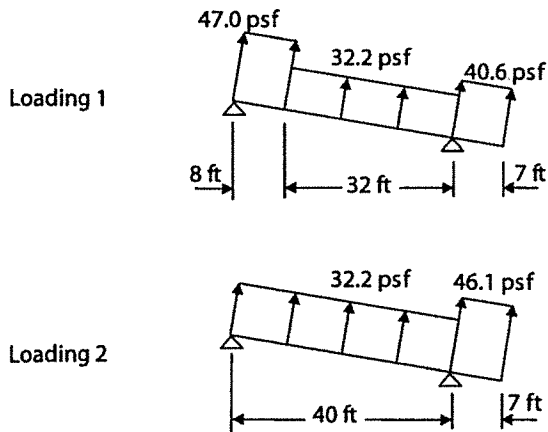
Roof joist design pressures need careful interpretation. The high pressures in corner or eave areas do not occur simultaneously at both ends. Two loading cases: wind loadings 1, 2 for joist 1 and wind loadings 3, 4 for joist 2, are shown in Figure 3-32 based on the following zones:

- Joist 1, loading 1: Zones 2 and 3 for roof and Zone 2 for overhang
- Joist 1, loading 2: Zone 2 for roof and Zones 2 and 3 for overhang
- Joist 2, loading 3: Zones 1 and 2 for roof and Zone 1 for overhang
- Joist 2, loading 4: Zone 1 for roof and Zones 1 and 2 for overhang

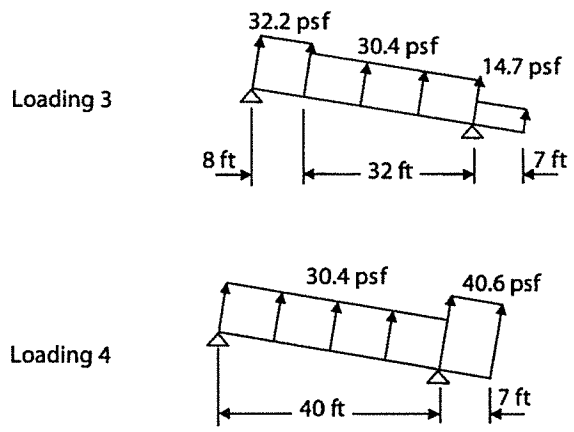
For simplicity, only one zone is used for overhang pressures in Figure 3-32.



**Loading on Joist 1**



**Loading on Joist 2**



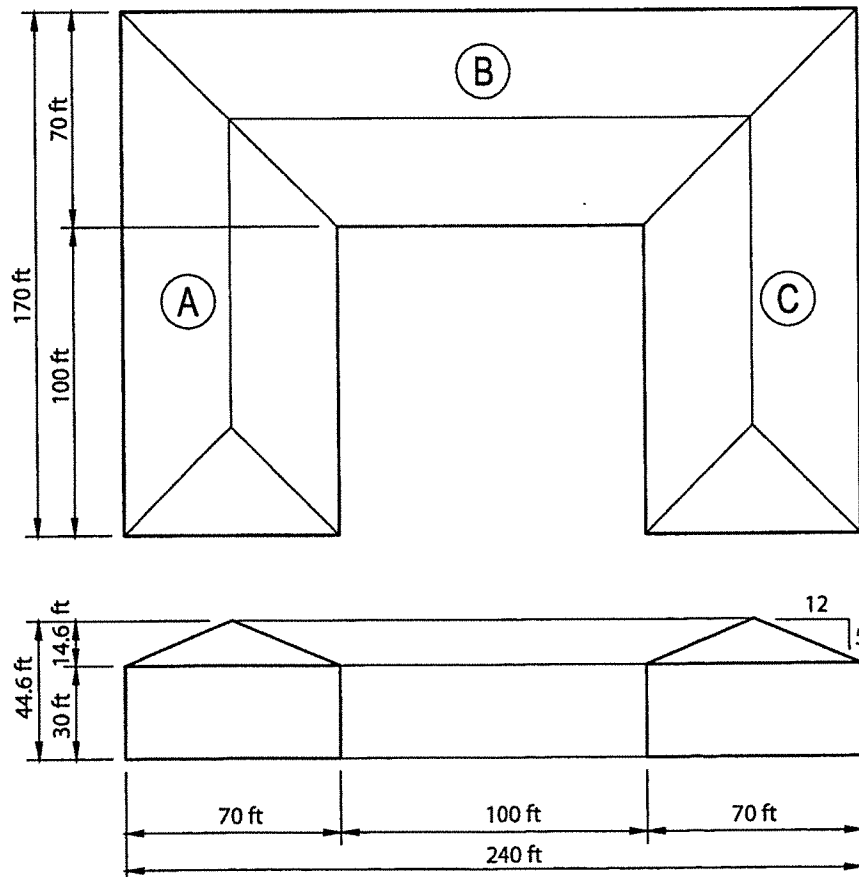
**Figure 3-32** Design Pressures for Typical Joists and Pressure Zones for Roof Components and Cladding

### 3.9 Example 9 U-Shaped Apartment Building

This example demonstrates calculation of wind loads for a U-shaped apartment building, shown in Figure 3-33. Data for the building are provided below:

<i>Location:</i>	Birmingham, Alabama
<i>Topography:</i>	Homogeneous
<i>Terrain:</i>	Suburban
<i>Dimensions:</i>	170 ft × 240 ft overall in plan Roof eave height of 30 ft Hip roof with 5 on 12 pitch
<i>Framing:</i>	Typical timber construction Wall studs are spaced at 16 in. on center, 10 ft tall Roof rafters are spaced at 16 in. on center, spanning 15 ft between interior or exterior bearing walls Floor and roof slabs provide diaphragm action
<i>Cladding:</i>	Location is outside a wind-borne debris region, so no glazing protection is required. Window units are 3 ft × 4 ft

The building is non-symmetrical, and therefore is ineligible for design by Method 1, Simplified Procedure, of ASCE 7-02. Method 2, Analytical Procedure is used. The building is less than 60 ft tall, so it is possible to use low-rise provisions of Section 6.5.12.2.2. However, because U-, T-, and L-shaped



**Figure 3-33** 240-ft × 170-ft U-shaped Apartment Building

buildings are not specifically covered, the adaptation of the low-rise “pseudo pressure” coefficients to buildings outside the scope of the research is not recommended. Therefore, use the “all heights method” of Section 6.5.12.2.1 of the Standard.

**Exposure** The building is located in a suburban area; according to Section 6.5.6.3 of the Standard, Exposure B is used.

**Building Classification** The building function is residential. It is not considered an essential facility, nor is it likely to be occupied by 300 persons in a single area at one time. Therefore, building Category II is appropriate (see Table 1-1 of the Standard).

**Enclosure** The building is designed to be enclosed. It is not located within a wind-borne debris region, so glazing protection is not required.

**Basic Wind Speed** Selection of the basic wind speed is addressed in Section 6.5.4 of the Standard. Birmingham, Alabama, is located just inside the 90-mph contour; therefore, the basic wind speed  $V = 90$  mph (see Figure 6-1b of the Standard).

**Velocity Pressures (Table 3-42)** The velocity pressures are computed using the following equation:

$$q_z = 0.00256 K_z K_{zt} K_d V^2 I \text{ psf} \quad (\text{Eq. 6-15})$$

where

- $K_z$  = Value obtained from Table 6-3 of the Standard: Case 1 for C&C and Case 2 for MWFRS
- $K_{zt}$  = 1.0 for homogeneous topography
- $K_d$  = 0.85 for buildings (see Table 6-4 of the Standard)
- $V$  = 90 mph
- $I$  = 1.0 for Category II classification (see Table 6-1 of the Standard)

$$\begin{aligned} q_z &= 0.00256 K_z (1.0) (0.85) (90)^2 (1.0) \\ &= 17.63 K_z \text{ psf} \end{aligned}$$

Values for  $K_z$  and the resulting velocity pressures are given in Table 3-42 below. The mean roof height is the average of the eave and the peak:

$$h = (30 + 44.6) / 2 = 37.3 \text{ ft}$$

At the mean roof height,  $h = 37.3$  ft; the velocity pressure is  $q_h = 13.2$  psf.

**Table 3-42**  $q_z$  Velocity Pressures

Height (ft)	MWFRS		C&C	
	$K_z$	$q_z$ (psf)	$K_z$	$q_z$ (psf)
0-15	0.57	10.1	0.70	12.3
20	0.62	10.9	0.70	12.3
30	0.70	12.3	0.70	12.3
Mean roof ht = 37.3	0.75	13.2	0.75	13.2

External Pressure  
Coefficients ( $C_p$ )

The values for the external pressure coefficients for the various surfaces (Tables 3-43 through 3-46) are obtained from Figure 6-6 of the Standard for each of the surfaces in Figure 3-34. The determination of certain pressure coefficients is based on aspect ratios. Even though this U-shaped building will be broken into pieces for the application of pressures, the overall dimensions have greater influence on the MWFRS pressure coefficients than the dimensions of the individual pieces. Therefore, the overall dimensions  $L$  and  $B$  are used.

When the wind is normal to wall W2, the wind blows over the "A" wing, crosses the courtyard in the middle of the U, and strikes the "C" wing. Although some reduction in the pressures on the "C" wind may occur due to the shielding offered by "A," it is impossible to predict without a wind tunnel study. Therefore, the pressures on the "C" wind are taken as the same as on the "A" wing.

For wind normal to surface W2 or W4:

$$L/B = 240/170 = 1.41$$

$$h/L = 37.3/240 = 0.16$$

$$\theta = 22.6^\circ \text{ for a 5-in-12 slope}$$

For wind normal to surface W3 or W1-W7-W5:

$$L/B = 170/240 = 0.71$$

$$h/L = 37.3/170 = 0.22$$

$$\theta = 22.6^\circ \text{ for a 5-in-12 slope}$$

The windward wall  $C_p$  is always 0.8, the side walls are  $-0.7$ , and the leeward wall varies with the aspect ratio  $L/B$ .

**Table 3-43** External Pressure Coefficients ( $C_p$ ) for Wind Normal to Wall W2

Surface type	Surface designation	Surface	Case	$L/B$ or $h/L$	$C_p$
Walls	W2, W6	Windward		All	+0.80
	W4, W8	Leeward		1.41	-0.42
	W1, W3, W5, W7	Side		All	-0.70
Roofs ( $\perp$ to ridge)	A1, C2	Windward	Negative	0.16	-0.25
			Positive	0.16	+0.25
Roofs ( $\parallel$ to ridge)	A2, C1	Leeward		0.16	-0.60
	A3, C3	Side	0 to $h$	0.16	-0.90*
			$h$ to $2h$	0.16	-0.50*
			$> 2h$	0.16	-0.30*
	B1, B2	Side		0 to $h$	0.16
			$h$ to $2h$	0.16	-0.50*
			$> 2h$	0.16	-0.30*

\*The values of smaller uplift pressures ( $C_p = -0.18$ ) on the roof can become critical when wind load is combined with roof live load or snow load; load combinations are given in Sections 2.3 and 2.4 of the Standard. For brevity, loading for this value is not shown here.

**Table 3-44** External Pressure Coefficients ( $C_p$ ) for Wind Normal to Wall W4

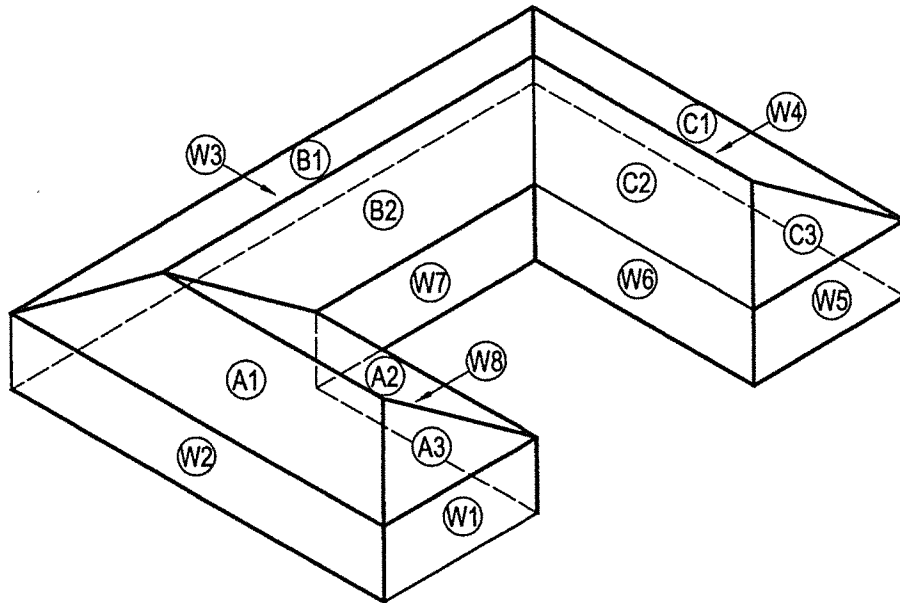
<i>Surface type</i>	<i>Surface designation</i>	<i>Surface</i>	<i>Case</i>	<i>L/B or h/L</i>	<i>C<sub>p</sub></i>
Walls	W4, W8	Windward		All	+0.80
	W6, W2	Leeward		1.41	-0.42
	W1, W3, W5, W7	Side		All	-0.70
Roofs ( $\perp$ to ridge)	C1, A2	Windward	Negative	0.16	-0.25
			Positive	0.16	+0.25
	C2, A1	Leeward		0.16	-0.60
Roofs ( $\parallel$ to ridge)	A3, C3	Side	0 to $h$	0.16	-0.90
			$h$ to $2h$	0.16	-0.50
	B1, B2	Side	0 to $h$	0.16	-0.90
			$h$ to $2h$	0.16	-0.50
		$> 2h$	0.16	-0.30	

**Table 3-45** External Pressure Coefficients ( $C_p$ ) for Wind Normal to Wall W3

<i>Surface type</i>	<i>Surface designation</i>	<i>Surface</i>	<i>Case</i>	<i>L/B or h/L</i>	<i>C<sub>p</sub></i>
Walls	W3	Windward		All	+0.80
	W1, W7, W5	Leeward		0.71	-0.50
	W2, W4, W6, W8	Side		All	-0.70
Roofs ( $\perp$ to ridge)	B1	Windward	Negative	0.22	-0.25
			Positive	0.22	+0.25
	A3, B2, C3	Leeward		0.22	-0.60
Roofs ( $\parallel$ to ridge)	A1, A2, C1, C2	Side	0 to $h$	0.22	-0.90
			$h$ to $2h$	0.22	-0.50
			$> 2h$	0.22	-0.30

**Table 3-46** External Pressure Coefficients ( $C_p$ ) for Wind Normal to Wall W1-W7-W5

<i>Surface type</i>	<i>Surface designation</i>	<i>Surface</i>	<i>Case</i>	<i>L/B or h/L</i>	<i>C<sub>p</sub></i>
Walls	W1, W7, W5	Windward		All	+0.80
	W3	Leeward		0.71	-0.50
	W2, W4, W6, W8	Side		All	-0.70
Roofs ( $\perp$ to ridge)	A3, B2, C3	Windward	Negative	0.22	-0.25
			Positive	0.22	+0.25
	B1	Leeward		0.22	-0.60
Roofs ( $\parallel$ to ridge)	A1, A2, C1, C2	Side	0 to $h$	0.22	-0.90
			$h$ to $2h$	0.22	-0.50
			$> 2h$	0.22	-0.30



**Figure 3-34** Surface Designations

The roof  $C_{ps}$  for wind normal to a ridge vary with roof angle and aspect ratio,  $h/L$ .  $h/L \leq 0.25$  for all wind directions. The roof angle  $\theta$  is always  $22.6^\circ$ , so interpolate between  $20^\circ$  and  $25^\circ$ . The  $C_p$  for wind parallel to a ridge varies with  $h/L$  and with distance from the leading edge of the roof.

### Design Wind Pressures for the MWFRS

The design pressures for this building are obtained by the equation

$$p = qGC_p - q_i(GC_{pi}) \quad (\text{Eq. 6-17})$$

where

- $q$  =  $q_z$  for windward wall at height  $z$  above ground
- $q$  =  $q_h = 13.2$  psf for leeward wall, side walls, and roof
- $q_i$  =  $q_h = 13.2$  psf for all surfaces since the building is enclosed
- $G$  = 0.85, the gust effect factor for rigid buildings and structures
- $C_p$  = External pressure coefficient for each surface as shown in Tables 3-43 through 3-46
- $(GC_{pi})$  =  $\pm 0.18$ , the internal pressure coefficient for enclosed buildings

For windward walls:

$$\begin{aligned} p &= q_z GC_p - q_h (GC_{pi}) \\ &= q_z (0.85) C_p - 13.2 (\pm 0.18) \\ &= 0.85 q_z C_p \pm 2.4 \end{aligned}$$

For all other surfaces:

$$\begin{aligned} p &= q_h GC_p - q_h (GC_{pi}) \\ &= 13.2 (0.85) C_p - 13.2 (\pm 0.18) \\ &= 11.2 C_p \pm 2.4 \end{aligned}$$

## Design Wind Load Cases

Section 6.5.12.3 of the Standard requires that any building whose wind loads have been determined under the provisions of Sections 6.5.12.2.1 and 6.5.12.2.3 shall be designed for wind load cases as defined in Figure 6-9. Case 1 includes the loadings determined in this example and shown in Tables 3-47 and 3-50. A combination of windward ( $P_W$ ) and leeward ( $P_L$ ) loads are applied for Load Cases 2, 3, and 4 as shown in Figure 3-35.

## Design Pressures for C&C

Design pressure for C&C is obtained by the following equation:

$$p = q_h [(GC_p) - (GC_{pi})] \quad (\text{Eq. 6-22})$$

where

$$\begin{aligned} q_h &= 13.2 \text{ psf for Case 1} \\ (GC_p) &= \text{External pressure coefficient (see Figure 6-11 of the Standard)} \\ (GC_{pi}) &= \pm 0.18, \text{ the internal pressure coefficient for enclosed buildings} \end{aligned}$$

## Wall Design Pressures (Table 3-51)

The pressure coefficients ( $GC_p$ ) are a function of effective wind area. The definition of effective wind area for a C&C panel is the span length multiplied by an effective width that need not be less than one-third the span length (see Section 6.2 of the Standard). The effective wind areas,  $A$ , for wall components are as follows:

Window Unit:

$$A = 3(4) = 12 \text{ ft}^2 \text{ (controls)}$$

**Table 3-47** External Pressures for Wind Normal to Wall W2

Surface type	Surface designation	z or x (ft)	q (psf)	$C_p$	External pressure (psf)	Design pressures (psf)	
						(+GC <sub>pi</sub> )	(-GC <sub>pi</sub> )
Walls	W2, W6	0 to 15	10.1	+0.80	+6.9	+4.5	+9.3
		20	10.9	+0.80	+7.4	+5.0	+9.8
		30	12.3	+0.80	+8.4	+6.0	+10.8
	W4, W8	0 to 30	13.2	-0.42	-4.7	-7.1	-2.3
	W1, W3, W5, W7	0 to 30	13.2	-0.70	-7.9	-10.3	-5.5
Roofs (⊥ to ridge)	A1, C2		13.2	-0.25	-2.8	-5.2	-0.4
			13.2	+0.25	+2.8	+0.4	+5.2
			13.2	-0.60	-6.7	-9.1	-4.3
Roofs (   to ridge)	A3, C3	0 to 37.3	13.2	-0.90	-10.1	-12.5	-7.7
		37.3 to 70	13.2	-0.50	-5.6	-8.0	-3.2
	B1 & B2	0 to 37.3	13.2	-0.90	-10.1	-12.5	-7.7
		37.3 to 74.6	13.2	-0.50	-5.6	-8.0	-3.2
	74.6 to 240	13.2	-0.30	-3.4	-5.8	-1.0	

Note:  $q_h = 13.2$  psf;  $G = 0.85$ .

**Table 3-48** External Pressures for Wind Normal to Wall W4

Surface type	Surface designation	z or x (ft)	q (psf)	$C_p$	External pressure (psf)	Design pressures (psf)	
						(+GC <sub>pi</sub> )	(-GC <sub>pi</sub> )
Walls	W4, W8	0 to 15	10.1	+0.80	+6.9	+4.5	+9.3
		20	10.9	+0.80	+7.4	+5.0	+9.8
		30	12.3	+0.80	+8.4	+6.0	+10.8
	W6, W2	0 to 30	13.2	-0.42	-4.7	-7.1	-2.3
	W1, W3, W5, W7	0 to 30	13.2	-0.70	-7.9	-10.3	-5.5
Roofs (⊥ to ridge)	C1, A2		13.2	-0.25	-2.8	-5.2	-0.4
			13.2	+0.25	+2.8	+0.4	+5.2
		C2, A1	13.2	-0.60	-6.7	-9.1	-4.3
Roofs (   to ridge)	A3, C3	0 to 37.3	13.2	-0.90	-10.1	-12.5	-7.7
		37.3 to 70	13.2	-0.50	-5.6	-8.0	-3.2
	B1, B2	0 to 37.3	13.2	-0.90	-10.1	-12.5	-7.7
		37.3 to 74.6	13.2	-0.50	-5.6	-8.0	-3.2
		74.6 to 240	13.2	-0.30	-3.4	-5.8	-1.0

Note:  $q_h = 13.2$  psf;  $G = 0.85$ .

**Table 3-49** External Pressures for Wind Normal to Wall W3

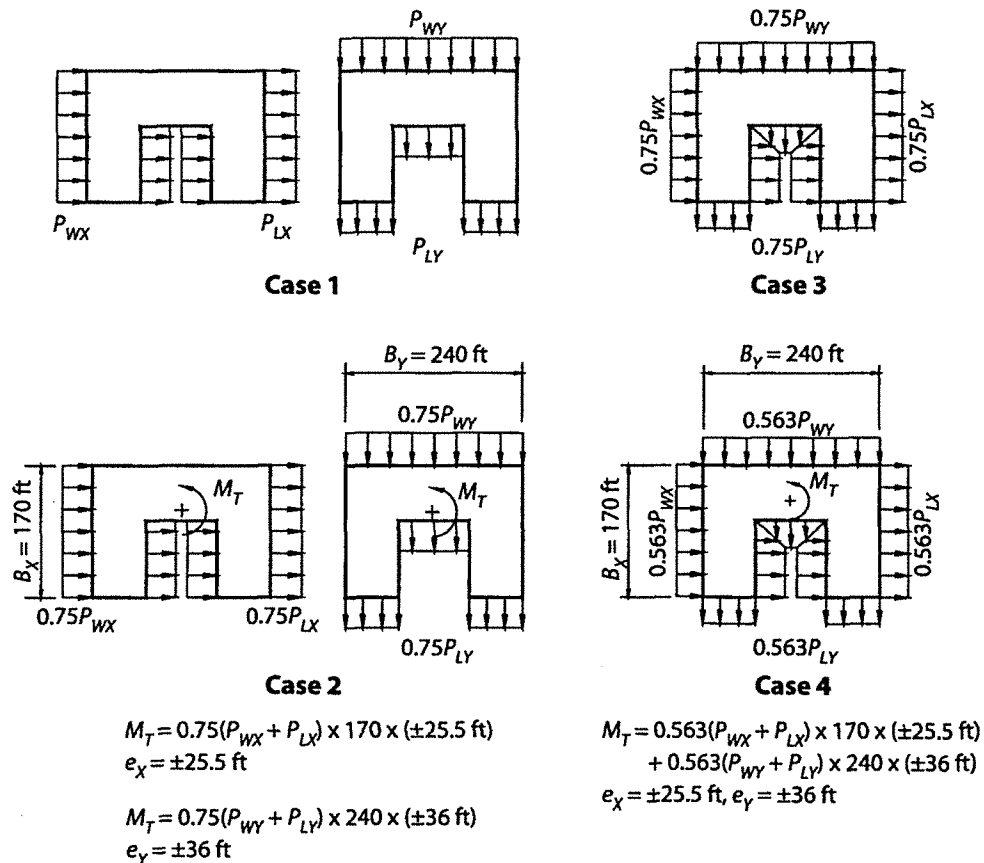
Surface type	Surface designation	z (ft)	q (psf)	$C_p$	External pressure (psf)	Design pressures (psf)	
						(+GC <sub>pi</sub> )	(-GC <sub>pi</sub> )
Walls	W3	0 to 15	10.1	+0.80	+6.9	+4.5	+9.3
		20	10.9	+0.80	+7.4	+5.0	+9.8
		30	12.3	+0.80	+8.4	+6.0	+10.8
	W1, W7, W5	0 to 30	13.2	-0.50	-5.6	-8.0	-3.2
	W2, W4, W6, W8	0 to 30	13.2	-0.70	-7.9	-10.3	-5.5
Roofs (⊥ to ridge)	B1		13.2	-0.25	-2.8	-5.2	-0.4
			13.2	+0.25	+2.8	+0.4	+5.2
		A3, B2, C3	13.2	-0.60	-6.7	-9.1	-4.3
Roofs (   to ridge)	A1, A2, C1, C2	0 to 37.3	13.2	-0.90	-10.1	-12.5	-7.7
		37.3 to 74.6	13.2	-0.50	-5.6	-8.0	-3.2
			74.6 to 170	13.2	-0.30	-3.4	-5.8

Note:  $q_h = 13.2$  psf;  $G = 0.85$ .

**Table 3-50** External Pressures for Wind Normal to Wall W1-W7-W5

Surface type	Surface designation	z (ft)	q (psf)	$C_p$	External pressure (psf)	Design pressures (psf)	
						( $+GC_{pi}$ )	( $-GC_{pi}$ )
Walls	W1, W7, W5	0 to 15	10.1	+0.80	+6.9	+4.5	+9.3
		20	10.9	+0.80	+7.4	+5.0	+9.8
		30	12.3	+0.80	+8.4	+6.0	+10.8
	W3	0 to 30	13.2	-0.50	-5.6	-8.0	-3.2
	W2, W4, W6, W8	0 to 30	13.2	-0.70	-7.9	-10.3	-5.5
Roofs ( $\perp$ to A3, B2, C3 ridge)	B1		13.2	-0.25	-2.8	-5.2	-0.4
			13.2	+0.25	+2.8	+0.4	+5.2
			13.2	-0.60	-6.7	-9.1	-4.3
Roofs ( $\parallel$ to A1, A2, C1, C2 ridge)	C1, C2	0 to 37.3	13.2	-0.90	-10.1	-12.5	-7.7
		37.3 to 74.6	13.2	-0.50	-5.6	-8.0	-3.2
		74.6 to 170	13.2	-0.30	-3.4	-5.8	-1.0

Note:  $q_h = 13.2$  psf;  $G = 0.85$ .



**Figure 3-35** Design Wind Load Cases for Wind Normal to Wall W2 and W3

**Table 3-51** Wall ( $GC_p$ ) for Ex. 9

Component	A (ft <sup>2</sup> )	$GC_p$		
		Zones 4 and 5 (+ $GC_p$ )	Zone 4 (- $GC_p$ )	Zone 5 (- $GC_p$ )
Window	12	+0.99	-1.09	-1.37
Wall Stud	33.3	+0.91	-1.01	-1.22

**Table 3-52** Controlling Design Pressures for Wall Components (psf)

Component	Design pressure (psf)			
	Zone 4		Zone 5	
	Positive	Negative	Positive	Negative
Window unit	+15.4	-16.8	+15.4	-20.5
Mullion	+14.4	-15.7	+14.4	-18.5

Wall Stud:

larger of

$$A = 10(1.33) = 13.3 \text{ ft}^2$$

or

$$A = 10(10/3) = 33.3 \text{ ft}^2 \text{ (controls)}$$

Width of Corner Zone 5:

smaller of

$$a = 0.1(170) = 17 \text{ ft}$$

or

$$a = 0.1(240) = 24 \text{ ft}$$

or

$$a = 0.4(37.3) = 14.9 \text{ ft (controls)}$$

but not less than the smaller of

$$a = 0.04(170) = 6.8 \text{ ft}$$

$$a = 0.04(240) = 9.6 \text{ ft}$$

and not less than

$$a = 3 \text{ ft}$$

**Typical Design Pressure  
Calculations**  
(Table 3-52)

Controlling negative design pressure for window unit in Zone 4 of walls:

$$= 13.2[(-1.09) - (\pm 0.18)]$$

$$= -16.8 \text{ psf (positive internal pressure controls)}$$

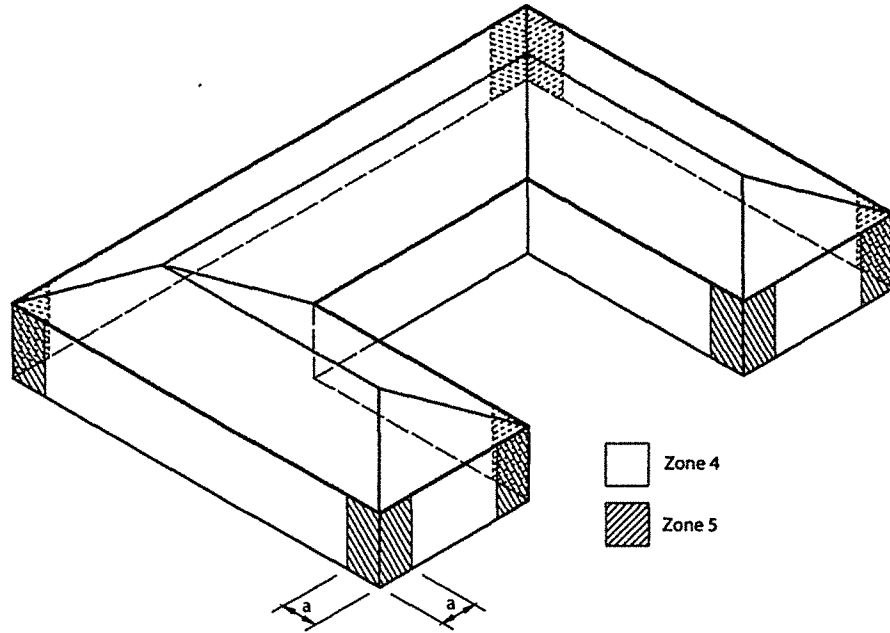
Controlling positive design pressure for window unit in Zone 4 of walls:

$$= 13.2[(+0.99) - (\pm 0.18)]$$

$$= 15.4 \text{ psf (negative internal pressure controls)}$$

The design pressures are the algebraic sum of external and internal pressures. Controlling negative pressure is obtained with positive internal pressure, and controlling positive pressure is obtained with negative internal pressure.

The edge zones for the walls are arranged at exterior corners, as shown in Figure 3-36.



**Figure 3-36** Component and Cladding Wall Pressure Zones

*Roof Design Pressures  
(Tables 3-53 and 3-54)*

The C&C roof pressure coefficients are given in Figure 6-11 of the Standard. The pressure coefficients are a function of the effective wind area. The definition of effective wind area for a component or cladding panel is the span length multiplied by an effective width that need not be less than one-third the span length (see Section 6.2 of the Standard). The effective wind areas,  $A$ , for the roof rafters are as follows:

Roof Rafter:

larger of

$$A = 15(1.33) = 20 \text{ ft}^2$$

or

$$A = 15(15/3) = 75 \text{ ft}^2 \text{ (controls)}$$

Note 7 of Figure 6-11C of the Standard says that for hip roofs with  $\theta \leq 25^\circ$ , Zone 3 may be treated as Zone 2.

The design pressures are the algebraic sum of external and internal pressures. Controlling negative pressure is obtained with positive internal pressure, and controlling positive pressure is obtained with negative internal pressure.

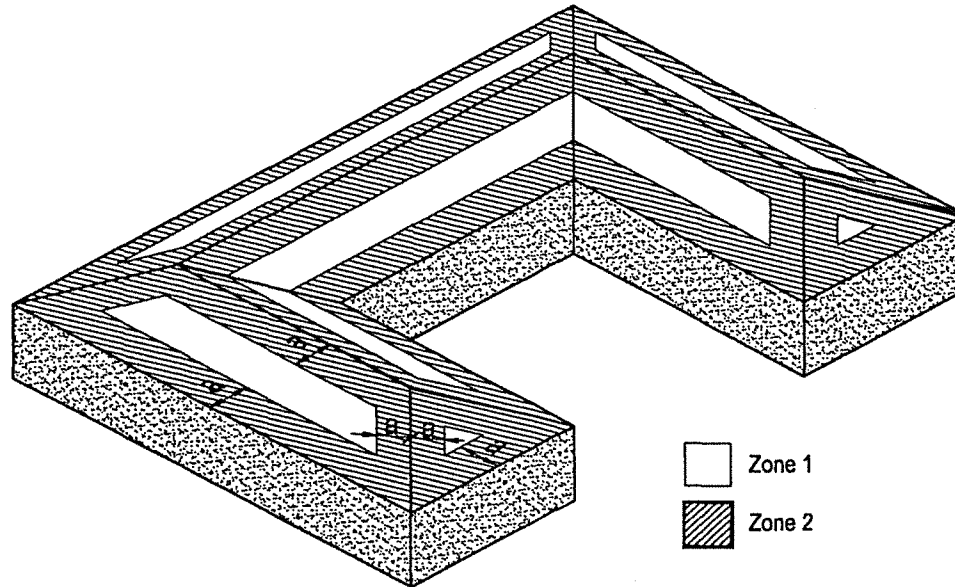
The edge zones for the hip roof are arranged as shown in Figure 3-37.

**Table 3-53** Roof External Pressure Coefficients ( $GC_p$ )

$A$ ( $\text{ft}^2$ )	External pressure coefficient		
	Positive	Negative	
	Zones 1, 2	Zone 1	Zone 2
	$GC_p$	$GC_p$	$-GC_p$
75	+0.32	-0.81	-1.26

**Table 3-54** Roof Design Pressures (psf)

Component	Design pressure (psf)		
	Zones 1, 2 Positive	Zone 1 Negative	Zone 2 Negative
Roof rafter	+6.6	-13.1	-19.0



**Figure 3-37** Component and Cladding Roof Pressure Zones

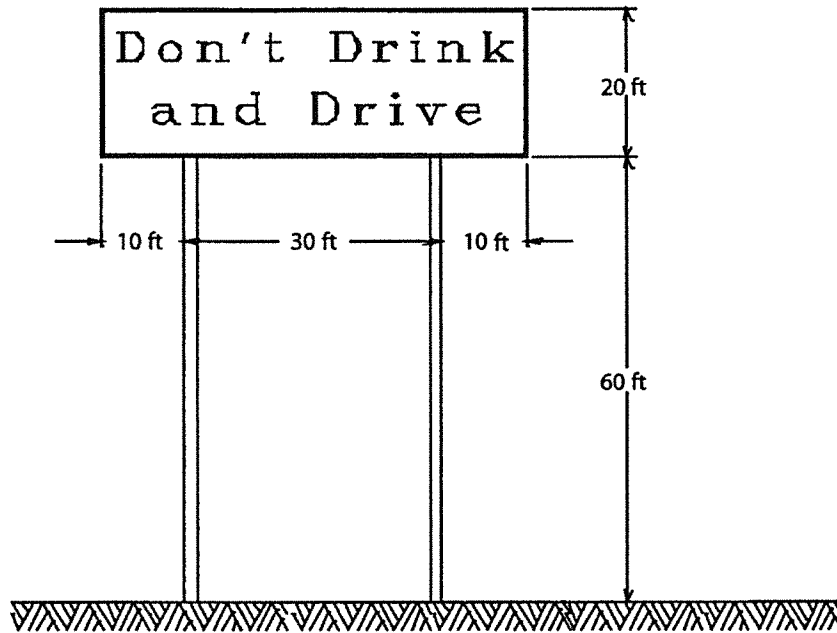
### 3.10 Example 10 50-ft × 20-ft Billboard Sign on Poles (Flexible) 60 ft Above Ground

In this example, design wind-forces for a tall billboard solid sign are determined. The example illustrates two items: (1) determination of  $G_f$  for a flexible structure, and (2) use of force coefficient for other structures. The dimensions of the billboard sign are shown in Figure 3-38. The billboard sign data are as follows:

<i>Location:</i>	Interstate highway in Iowa
<i>Terrain:</i>	Flat and open terrain
<i>Dimensions:</i>	50-ft × 20-ft sign mounted on two 16-in.-diameter steel pipe supports; bottom of the sign is 60 ft above ground
<i>Structural characteristics:</i>	Tall flexible structure; estimated fundamental frequency is 0.7 Hz and critical damping ratio is 0.01 (The natural frequency of a structure can be calculated in different ways. It has been predetermined for this example.)

#### Exposure and Building Classification

The sign is located in an open area. It does not fit Exposures B or D; therefore, Exposure C is used (see Sections 6.5.6.2 and 6.5.6.3 of the Standard).



**Figure 3-38** Dimensions of a Billboard Sign on an Interstate Highway

Failure of the sign represents low hazard to human life since it is located away from the highway and is not in a populated area. The structure can be classified as Category I (see Table 1-1).

**Basic Wind Speed**

The wind speed map (Figure 6-1 of the Standard) has only one value of wind speed in the middle of the country. Exact location of the sign in Iowa is not important. The basic wind speed  $V = 90$  mph.

**Velocity Pressures (Table 3-55)**

The velocity pressures are computed using the following equation:

$$q_z = 0.00256 K_z K_{zt} K_d V^2 I \text{ psf} \quad (\text{Eq. 6-15})$$

where

- $V = 90$  mph
- $I = 0.87$  for Category I (see Table 6-1 of the Standard)
- $K_{zt} = 1.0$  because of flat terrain
- $K_d = 0.85$  for solid sign (see Table 6-4 of the Standard)
- $K_z =$  Values from Table 6-3 of the Standard for  $z$  of 30, 60, and 80 ft.

More divisions of  $z$  are not justified because loads on pipe supports are small compared to the ones on the sign.

**Table 3-55** Velocity Pressures (psf)

Height (ft)	$K_z$	$q_z$ (psf)
30	0.98	15.0
60	1.13	17.3
80	1.21	18.6

## Design Force for MWFRS

The design force for the MWFRS is given by

$$F = q_z G C_f A_f \quad (\text{Eq. 6-25})$$

where

- $q_z$  = Value as determined previously
- $G$  = Gust effect factor to be calculated by Eq. 6-4 because  $f < 1$  Hz.
- $A_f$  =  $50 \times 20 = 1,000$  ft<sup>2</sup>; for normal and oblique wind, see Note 4 in Figure 6-20 of the Standard
- $C_f$  = Force coefficient values from Figures 6-19 and 6-20 of the Standard

### Force Coefficient ( $C_f$ )

This sign qualifies as an above ground-level sign (see Figure 6-20 of the Standard):

$$M/N = 2.5$$

$$C_f = 1.2$$

The supports are round. From Figure 6-19 of the Standard:

$$D\sqrt{q_z} = 1.33\sqrt{15.0} = 5.2 > 2.5$$

and

$$h/D = 60/1.33 = 45$$

For moderately smooth surface:

$$C_f = 0.7$$

### Gust Effect Factor ( $G$ )

The gust effect factor,  $G$ , is determined from Eq. 6-8:

$$G = 0.925 \left[ \frac{1 + 1.7 I_z \sqrt{g_Q^2 Q^2 + g_R^2 R^2}}{1 + 1.7 g_V I_z} \right]$$

where

- $I_z$  = Value from Eq. 6-5 of the Standard
- $g_Q, g_V$  = Value taken as 3.4 (see Section 6.5.8.2 of the Standard)
- $g_R$  = Value from Eq. 6-9 of the Standard
- $Q$  = Value determined from Eq. 6-6 of the Standard
- $R$  = Value determined from Eq. 6-1 of the Standard
- $\bar{z}$  = Equivalent height of the structure, it is used to determine nominal value of  $I_z$ ; for buildings, the recommended value is  $0.6h$ , but for the sign, it is the middle of the billboard area or 70 ft
- $c, l, \bar{\epsilon}$  = Value given in Table 6-2 of the Standard

$$I_z = c \left( \frac{33}{\bar{z}} \right)^{1/6} = 0.2 \left( \frac{33}{70} \right)^{1/6} = 0.176 \quad (\text{Eq. 6-5})$$

$$L_z = l \left( \frac{z}{33} \right)^{\bar{e}} = 500 \left( \frac{70}{33} \right)^{1/5} = 581 \text{ ft} \quad (\text{Eq. 6-7})$$

$$Q^2 = \frac{1}{1 + 0.63 \left[ \frac{B+h}{L_z} \right]^{0.63}} \quad (\text{Eq. 6-6})$$

$$= \frac{1}{1 + 0.63 \left[ \frac{50+20}{581} \right]^{0.63}} = 0.858$$

Note: In Eq. 6-6,  $B$  and  $h$  are the dimensions of the sign.

$$\bar{V}_z = \bar{b} \left( \frac{z}{33} \right)^{\bar{a}} V \left( \frac{88}{60} \right) = 0.65 \left( \frac{70}{33} \right)^{1/5} (90) \left( \frac{88}{60} \right) = 96.3 \quad (\text{Eq. 6-14})$$

Note:  $V$  is the basic (3-s gust) wind speed in mph.

$$N_1 = \frac{n_1 L_z}{\bar{V}_z} = \frac{(0.7)(581)}{96.3} = 4.22 \quad (\text{Eq. 6-12})$$

Note:  $n_1$  is the fundamental frequency of the structure.

$$R_n = \frac{7.47 N_1}{(1 + 10.3 N_1)^{5/3}} = 0.0564 \quad (\text{Eq. 6-11})$$

For  $R_p$

$$\eta = \frac{4.6 n_1 h}{\bar{V}_z} = \frac{(4.6)(0.7)(80)}{96.3} = 2.675$$

$$R_h = \frac{1}{\eta} - \frac{1}{2\eta^2} (1 - e^{-2\eta}) = 0.3043 \quad (\text{Eq. 6-13a})$$

Note:  $h$  is taken as 80 ft because resonance response depends on full height.

For  $R_B$  (assuming  $B = 50$  ft),

$$\eta = \frac{4.6 n_1 B}{\bar{V}_z} = \frac{(4.6)(0.7)(50)}{96.3} = 1.672 \quad (\text{Eq. 6-13a})$$

$$R_B = \frac{1}{\eta} - \frac{1}{2\eta^2} (1 - e^{-2\eta}) = 0.4255$$

For  $R_L$  (assuming depth  $L = 2$  ft),

$$\eta = \frac{15.4 n_1 L}{\bar{V}_z} = \frac{(15.4)(0.7)(2)}{96.3} = 0.2239 \quad (\text{Eq. 6-13a})$$

$$R_L = \frac{1}{\eta} - \frac{1}{2\eta^2} (1 - e^{-2\eta}) = 0.8661$$

$$g_R = \sqrt{2 \ln(3,600n_1)} + \frac{0.577}{\sqrt{2 \ln(3,600n_1)}} \quad (\text{Eq. 6-9})$$

$$g_R = 4.1$$

$$R^2 = \frac{1}{\beta} R_n R_k R_B (0.53 + 0.47 R_L) \quad (\text{Eq. 6-10})$$

$$= \frac{1}{0.01} (0.0564) (0.3043) (0.4255) [0.53 + (0.47) (0.8661)]$$

$$R^2 = 0.684$$

$$G_f = 0.925 \left[ \frac{1 + 1.7 I_z \sqrt{g_Q^2 Q^2 + g_R^2 R^2}}{1 + 1.7 g_v I_z} \right] \quad (\text{Eq. 6-8})$$

$$= 0.925 \left[ \frac{1 + 1.7 (0.176) \sqrt{(3.4)^2 (0.858) + (4.1)^2 (0.684)}}{1 + 1.7 (3.4) (0.176)} \right]$$

$$= 1.093$$

### Design Force

$$\text{Force, } F = q_z G_f C_f A_f$$

For one support:

$$0 \text{ to } 30 \text{ ft} \quad F = 15.0 (1.093) (0.7) (1.33) = 15.3 \text{ plf}$$

$$30 \text{ to } 60 \text{ ft} \quad F = 17.3 (1.093) (0.7) (1.33) = 17.7 \text{ plf}$$

For two supports:

$$0 \text{ to } 30 \text{ ft} \quad F = 30.6 \text{ plf}$$

$$30 \text{ to } 60 \text{ ft} \quad F = 35.4 \text{ plf}$$

For a 1-ft horizontal strip of the sign:

$$F = 18.6 (1.093) (1.2) (50) = 1,220 \text{ plf}$$

The force on the sign follows two cases (see Figure 3-39):

1. Force at geometric center
2. Force at  $0.2(50) = 10$  ft on either side of geometric center (see Note 4, Figure 6-20, of the Standard)

### Limitation

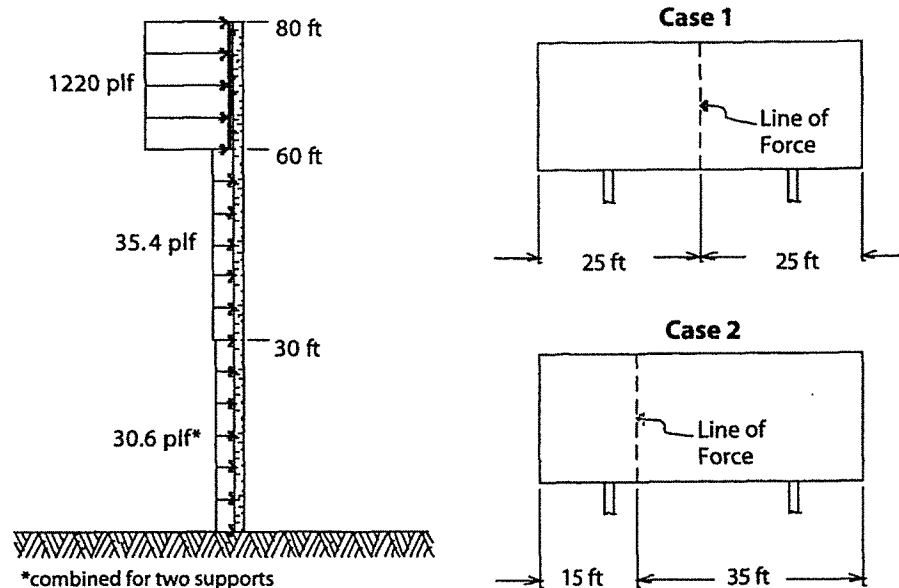
In certain circumstances for circular members, across-wind response due to vortex shedding can be critical. The Standard does not provide a procedure to assess across-wind response, but suggests obtaining guidance from recognized literature (see Section 6.5.2 of the Standard).

### Force on Components and Cladding

Eq. 6-25 of the Standard is

$$F = q_z G C_f A_f$$

The values of  $q_z$  are the same as MWFRS, except the value of  $G = 0.85$ . The design forces can be determined using appropriate  $C_f$  and  $A_f$  for each component or cladding panel.



**Figure 3-39** Design Forces for the Billboard Sign

### 3.11 Example 11 Domed Roof Building

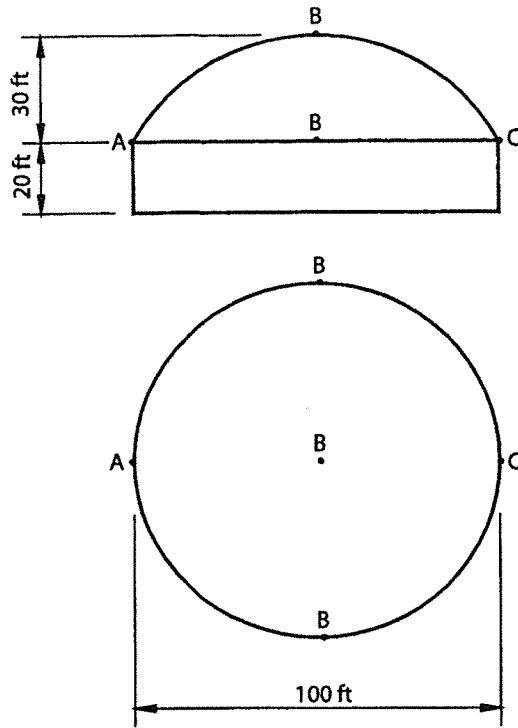
Figure 3-40 illustrates the domed roof building used in this example. Building data are as follows:

<i>Location:</i>	Baton Rouge, Louisiana
<i>Topography:</i>	Homogeneous
<i>Terrain:</i>	Open
<i>Dimensions:</i>	100 ft diameter in plan Eave height of 20 ft Dome roof height of 50 ft
<i>Framing:</i>	Steel framed dome roof Metal deck roofing
<i>Cladding:</i>	Location is outside a wind-borne debris region, so no glazing protection is required

Domed roofs are outside the scope of Method 1, Simplified Procedure, of ASCE 7-02. Method 2, Analytical Procedure, is used. The building is less than 60 feet tall, so it is possible to use low-rise provisions of Section 6.5.12.2.2. However, because dome-shaped roofs are not specifically covered, the adaptation of the low-rise “pseudo pressure” coefficients to buildings outside the scope of the research is not recommended. Therefore, the “all heights method” of Section 6.5.12.2.1 of the Standard is used.

#### Exposure

The building is located in an open terrain area; according to Section 6.5.6.3 of the Standard, Exposure C is used.



**Figure 3-40** 100-ft Diameter Domed Roof Building

**Building Classification**

The building is a church, so it will have more than 300 people congregating in one area. Therefore, building Category III is appropriate (see Table 1-1 of the Standard).

**Enclosure**

The building is designed to be enclosed. It is not located within a wind-borne debris region, so glazing protection is not required.

**Basic Wind Speed**

Selection of the basic wind speed is addressed in Section 6.5.4 of the Standard. Baton Rouge, Louisiana, is located halfway between the 100-mph and 110-mph contours; therefore, the basic wind speed  $V = 105$  mph (see Figure 6-1b of the Standards).

**Velocity Pressures**

The velocity pressures are computed using the following equation:

$$q_z = 0.00256 K_z K_{zt} K_d V^2 I \text{ psf} \quad (\text{Eq. 6-15})$$

where

- $K_z$  = Value obtained from Table 6-3 of the Standard: Case 1 for C&C and Case 2 for MWFRS
- $K_{zt}$  = 1.0 for homogeneous topography
- $K_d$  = 0.95 for round tanks and similar structures (see Table 6-4 of the Standard)
- $V$  = 105 mph
- $I$  = 1.15 for Category III classification (see Table 6-1 of the Standard)

**Table 3-56**  $q_z$  Velocity Pressures

Height (ft)	MWFRS		C&C	
	$K_z$	$q_z$ (psf)	$K_z$	$q_z$ (psf)
0-15	0.85	26.2	0.85	26.2
Eave height = 20	0.90	27.7	0.90	27.7
Top of dome = 50	1.09	33.6	1.09	33.6

$$q_z = 0.00256K_z(1.0)(0.95)(105)^2(1.15)$$

$$= 30.8 K_z \text{ psf}$$

Values for  $K_z$  and the resulting velocity pressures are given in Table 3-56. Wall pressures will be evaluated at mid-height = 20 ft/2 = 10 ft / 15 ft; use  $q_z$  at 15 ft.

### Design Wind Pressures for the MWFRS

#### Wall Pressures

The walls of a round building are not specifically covered by the Standard. The values for the force coefficients for round tanks and chimneys from Figure 6-19 are used to determine the effect of the wall pressures on the MWFRS. The values of the force coefficients for round tanks vary with the aspect ratio of height to diameter and with the surface roughness.

The value of  $q_z$  varies from 26.2 psf at the ground to 27.7 psf at the eave line. Therefore, the ratio  $D\sqrt{q_z}$  varies from  $100\sqrt{26.2} = 512$  to  $100\sqrt{27.7} = 527$ , both of which are much greater than 2.5; therefore, the first set of values for  $C_f$  for round tanks in Figure 6-19 of the Standard is used. Any projections on the exterior skin of the building are assumed to be less than 2 ft; therefore,  $D'/D$  would be less than 2 ft/100 ft = 0.02, so the building is considered moderately smooth. The height of the entire structure ( $h = 50$  ft) is used for the aspect ratio, since the wind has to travel over the dome. Therefore,  $h/D = 50 \text{ ft}/100 \text{ ft} = 0.5$ , which is less than 1, resulting in  $C_f = 0.5$ .

The force on the walls represents the total drag of the wind on the walls of the building, both windward and leeward. Since it is not the typical pressures applied normal to the wall surfaces, ignore internal pressures, as they cancel out in the net drag calculation.

$$\text{Total drag force on walls} = F = q_z G C_f A_f \quad (\text{Eq. 6-25})$$

where

$$q_z = q \text{ at the centroid of } A_f - \text{centroid of } A_f \text{ is at wall mid-height} = 20 \text{ ft}/2 = 10 \text{ ft}$$

$$q = 26.2 \text{ psf (at 10 ft)}$$

$$G = 0.85, \text{ the gust effect factor for rigid structures}$$

$$C_f = 0.5$$

$$A_f = 100 \text{ ft} \times 20 \text{ ft} = 2,000 \text{ sf}$$

$$\text{Total drag force on walls} = F = 26.2(0.85)(0.5)(2,000) = 22,270 \text{ lb}$$

*Domed Roof Pressures  
(Table 3-57)*

The roof pressure coefficients for a domed roof are taken from Figure 6-7 of the Standard. The height from the ground to the spring line of the dome,  $h_D = 20$  ft. The height of the dome itself from the spring line to the top of the dome,  $f = 30$  ft. Determine  $C_p$  for a rise to diameter ratio,  $f/D = 30/100 = 0.30$ ; and a base height to diameter ratio,  $h_D/D = 20/100 = 0.20$ . Interpolation from Figure 6-7 of the Standard is required.

Two load cases are required for the MWFRS loads on domes: Cases A and B. Case A is based on linear interpolation of  $C_p$  values from point A to B and from point B to C (see Figure 3-40 of this guide for the locations of points A, B, and C). Case B uses the pressure coefficient at A for the entire front area of the dome up to an angle  $\theta = 25^\circ$ , then interpolates the values for the rest of the dome as in Case A.

**Case A**

For design purposes, interpolate the pressure coefficients at points at 10-ft intervals along the dome. Values of pressure coefficients  $C_p$  are shown in Table 3-58.

**Case B**

Determine the point on the front of the dome at which  $\theta = 25^\circ$ . The point is 36.2 ft from the center of the dome, therefore 13.8 ft from point A. The pressure coefficient at A shall be used for the section from A to an arc 13.8 ft from A. The remainder of the dome pressures are based on linear interpolation between the  $25^\circ$  point and point B; and then from point B to C. Values of pressure coefficients  $C_p$  are shown in Table 3-59.

*Internal Pressure  
Coefficient for Domed  
Roof*

The building is not in a wind-borne debris region, so glazing protection is not required. The building is assumed to be an enclosed building.

**Table 3-57** Domed Roof  $C_p$  (at  $f/D = 0.30$ )

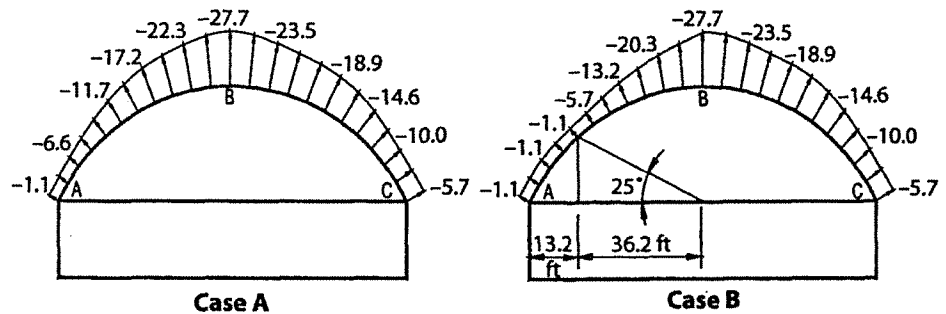
Point on dome	$h_D/D = 0$	$h_D/D = 0.20$	$h_D/D = 0.25$	$h_D/D = 0.50$
A	+0.5	-0.04	-0.18	-
B	-0.78	-0.97	-	-1.26
C	0	-0.20	-	-0.50

**Table 3-58** Interpolated Domed Roof  $C_p$  (Case A)

Segment	Start point	+10 ft	+20 ft	+30 ft	+40 ft	End point
A to B	-0.04	-0.23	-0.41	-0.60	-0.78	-0.97
B to C	-0.97	-0.82	-0.66	-0.51	-0.35	-0.20

**Table 3-59** Interpolated Domed Roof  $C_p$  (Case B)

Segment	Start point	+13.8 ft	+20 ft	+30 ft	+40 ft	End point
A to B	-0.04	-0.04	-0.20	-0.46	-0.71	-0.97
Segment	Start point	+10 ft	+20 ft	+30 ft	+40 ft	End point
B to C	-0.97	-0.82	-0.66	-0.51	-0.35	-0.20



**Figure 3-41** MWFRS External Pressures  
 Note: Internal pressure of  $\pm 6.1$  psf to be added.

The net pressure on any surface is the difference in the external and internal pressures on the opposites sides of that surface:

$$p = qGC_p - q_i(GC_{pi}) \quad (\text{Eq. 6-17})$$

For enclosed buildings:

$$GC_{pi} = \pm 0.18 \quad (\text{Figure 6-5})$$

$q_i$  is taken as  $q(h_D + f) = 33.6$  psf

Design internal pressure:

$$q_i(GC_{pi}) = 33.6 (\pm 0.18) = \pm 6.1 \text{ psf}$$

**Design Wind Pressures  
 for Domed Roof  
 (Figure 3-41)**

The design pressures for this building are obtained by the equation

$$p = qGC_p - q_i(GC_{pi}) \quad (\text{Eq. 6-17})$$

where

- $q = q(h_D + f) = 33.6$  psf
- $G = 0.85$ , the gust effect factor for rigid buildings and structures
- $C_p$  = External pressure coefficient
- $q_i = q_h$  for all surfaces since the building is enclosed
- $GC_{pi} = \pm 0.18$ , the internal pressure coefficient for enclosed buildings

Design pressure:

$$p = 33.6(0.85) C_p - 33.6(\pm 0.18) = 28.6 C_p \pm 6.1$$

Values of design pressures for MWFRS are shown in Table 3-60.

**Design Wind Load  
 Cases**

Section 6.5.12.3 of the Standard requires that any building whose wind loads have been determined under the provisions of Sections 6.5.12.2.1 and 6.5.12.2.3 shall be designed for wind load cases as defined in Figure 6-9. However, since the building is round, the cases as shown do not apply. There is a possibility of non-symmetrical action by the wind, causing some torsion. Load Case 2, with the reduced calculated horizontal load and moment using eccentricity of 15 ft, could be applied to the cylindrical wall portion of the building.

**Table 3-60** Domed Roof Design Pressures for MWFRS (psf)

Surface	Location (ft)	$C_p$	External pressure (psf)	Design pressures (psf)	
				(+ $GC_{pi}$ )	(- $GC_{pi}$ )
Domed roof:					
Case A	Point A - 0 ft	-0.04	-1.1	-7.2	5.0
	10	-0.23	-6.6	-12.7	-0.5
	20	-0.41	-11.7	-17.8	-5.6
	30	-0.60	-17.2	-23.3	-11.1
	40	-0.78	-22.3	-28.4	-16.2
	Point B - 50 ft	-0.97	-27.7	-33.8	-21.6
	60	-0.82	-23.5	-29.6	-17.4
	70	-0.66	-18.9	-25.0	-12.8
	80	-0.51	-14.6	-20.7	-8.5
	90	-0.35	-10.0	-16.1	-3.9
	Point C - 100 ft	-0.20	-5.7	-11.8	0.4
Domed roof:					
Case B	Point A - 0 ft	-0.04	-1.1	-7.2	5.0
	$\theta = 25^\circ$ ; 13.8 ft	-0.04	-1.1	-7.2	5.0
	20	-0.20	-5.7	-11.8	0.4
	30	-0.46	-13.2	-19.3	-7.1
	40	-0.71	-20.3	-26.4	-14.2
	Point B - 50 ft	-0.97	-27.7	-33.8	-21.6
	60	-0.82	-23.5	-29.6	-17.4
	70	-0.66	-18.9	-25.0	-12.8
	80	-0.51	-14.6	-20.7	-8.5
	90	-0.35	-10.0	-16.1	-3.9
	Point C - 100 ft	-0.20	-5.7	-11.8	0.4

**Design Pressures for C&C (Figure 3-42)**

Design pressure for components and cladding is obtained by the following equation:

$$p = q_h [(GC_p) - (GC_{pi})] \tag{Eq. 6-22}$$

where

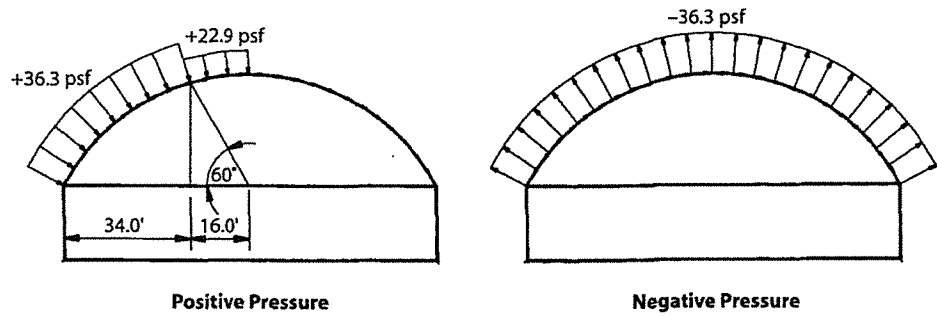
- $q_h = q_{(h_D+f)} = 33.6$  psf for all domed roofs calculated at height  $h_D + f$
- $q_i = q_{(h_D+f)} = 33.6$  psf for positive and negative internal pressure
- $(GC_p)$  = External pressure coefficient (see Figure 6-16 of the Standard)
- $(GC_{pi}) = \pm 0.18$  for internal pressure coefficient (see Figure 6-5 of the Standard)

**Wall Design Pressures**

The Standard does not address component and cladding wall loads for round buildings.

**Domed Roof Design Pressures (Table 3-61)**

The C&C domed roof pressure coefficients are given in Figure 6-16 of the Standard. This figure is valid only for domes of certain geometric parameters. The base height to diameter ratio,  $h_D/D = 20/100 = 0.20$ , which is in the range of 0 to 0.5 for Figure 6-16. The rise to diameter ratio,  $f/D =$



**Figure 3-42** Component Design Pressures

**Table 3-61** Roof External Pressure Coefficient ( $GC_p$ ) from Figure 6-16

Zone	External pressure coefficient ( $GC_p$ )	
	Positive	Negative
0° to 60°	+0.9	-0.9
60° to 90°	+0.5	-0.9

**Table 3-62** Roof Design Pressures (psf)

Zone	Design pressure (psf)	
	Positive	Negative
0° to 60°	+36.3	-36.3
60° to 90°	+22.9	-36.3

$30/100 = 0.30$  which is in the range of 0.2 to 0.5 for Figure 6-16. Therefore, it is valid to use Figure 6-16 for this dome.

The design pressures are the algebraic sum of external and internal pressures. Positive internal pressure provides controlling negative pressures, and negative internal pressure provides the controlling positive pressure. These design pressures act across the roof surface (interior to exterior).

$$p = qGC_p - q_i(GC_{pi})$$

$$p = 33.6GC_p - 33.6(\pm 0.18) = 33.6GC_p \pm 6.1$$

Design pressures are summarized in Table 3-62.

These pressures are for the front half of the dome. The back half would experience only the negative value of -36.3 psf. However, since all wind directions must be taken into account, and since each element would at some point be considered to be in the front half of the dome, each element must be designed for both positive and negative values.

### 3.12 Example 12 Unusually Shaped Building

This example demonstrates calculation of wind loads for an unusually shaped building, as shown in Figure 3-43. Building data are as follows:

<i>Location:</i>	San Francisco, California
<i>Topography:</i>	Homogeneous
<i>Terrain:</i>	Suburban
<i>Dimensions:</i>	100-ft $\times$ 100-ft overall in plan with a 70-ft $\times$ 70-ft wedge cut off Flat roof with eave height of 15 ft
<i>Framing:</i>	Steel joist, beam, column roof framing with X-bracing
<i>Cladding:</i>	Location is outside a wind-borne debris region, so no glazing protection is required.

Non-symmetrical buildings are outside the scope of Method 1, Simplified Procedure, of ASCE 7-02. Therefore, Method 2, Analytical Procedure, is used. The building is less than 60 ft tall, so it is possible to use low-rise provisions of Section 6.5.12.2.2. However, because unusually shaped buildings are not specifically covered, the adaptation of the low-rise “pseudo pressure” coefficients to buildings outside the scope of the research is not recommended. Therefore, the “all heights method” of Section 6.5.12.2.1 is used.

#### Exposure

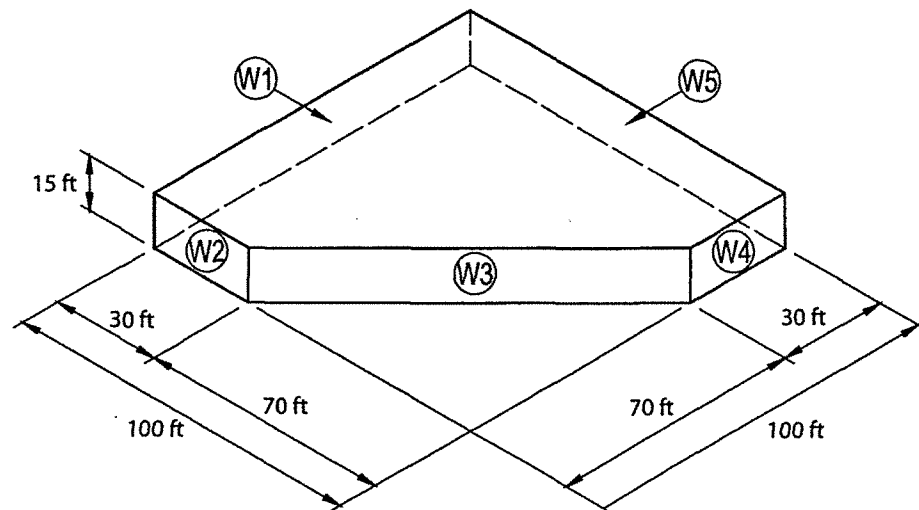
The building is located in a suburban terrain area; according to Section 6.5.6.3 of the Standard, Exposure B is used.

#### Building Classification

The building is an office building. It is not considered an essential facility, nor is it likely to be occupied by 300 persons in a single area at one time. Therefore, building Category II is appropriate (see Table 1-1 of the Standard).

#### Enclosure

The building is designed to be enclosed. It is not located within a wind-borne debris region, so glazing protection is not required.



**Figure 3-43** 100-ft  $\times$  100-ft Unusually Shaped Building

**Table 3-63**  $q_z$  Velocity Pressures

Height (ft)	MWFRS		C&C	
	$K_z$	$q_z$ (psf)	$K_z$	$q_z$ (psf)
0-15	0.57	9.0	0.70	11.0
Eave height = 15	0.57	9.0	0.70	11.0

**Basic Wind Speed**

Selection of the basic wind speed is addressed in Section 6.5.4 of the Standard. San Francisco, California, is located in the 85-mph zone; therefore, the basic wind speed  $V = 85$  mph (see Figure 6-1 of the Standard).

**Velocity Pressures**

The velocity pressures are computed using the following equation:

$$q_z = 0.00256 K_z K_{zt} K_d V^2 I \text{ psf} \quad (\text{Eq. 6-15})$$

where

$K_z$  = Value obtained from Table 6-3: Case 1 for C&C and Case 2 for MWFRS

$K_{zt}$  = 1.0 for homogeneous topography

$K_d$  = 0.85 for buildings (see Table 6-4 of the Standard)

$V$  = 85 mph

$I$  = 1.0 for Category II classification (see Table 6-1 of the Standard)

$$\begin{aligned} q_z &= 0.00256 K_z (1.0) (0.85) (85)^2 (1.0) \\ &= 15.72 K_z \text{ psf} \end{aligned}$$

The mean roof height for a flat roof is the eave height  $h = 15$  ft. Values for  $K_z$  and the resulting velocity pressures for MWFRS and C&C are shown in Table 3-63.

**External Pressure Coefficients ( $C_p$ )**

The values for the external pressure coefficients for the various surfaces are obtained from Figure 6-6 of the Standard for each of the surfaces of the building shown in Figure 3-43 of this guide. The determination of certain pressure coefficients is based on aspect ratios. The overall dimensions for  $L$  and  $B$  are used.

$$L/B = 100/100 = 1.00$$

$$h/L = 15/100 = 0.15$$

$$\theta = 0^\circ$$

The windward wall  $C_p$  is always 0.8, the side walls are always  $-0.7$ , and the leeward wall is  $-0.5$  based on an aspect ratio  $L/B = 1.0$ .

The roof  $C_p$ s come from the "wind parallel to a ridge" portion of Figure 6-6 of the Standard. For these flat roofs,  $C_p$  varies with  $h/L$  and with distance from the leading edge of the roof. For  $h/L = 0.15 \leq 0.5$ ,  $C_p = -0.9$ ,  $-0.5$ , or  $-0.3$ , depending on the distance from the leading edge. Figure 6-6 also includes the  $-0.18$  case for all roofs; however, this case causes critical loading when combined with transient loads such as snow load or live load. For brevity, the case is not shown.

External pressure coefficients are summarized in Tables 3-64 through 3-67.

**Table 3-64** External Pressure Coefficients ( $C_p$ ) for Wind Normal to Wall W1

<i>Surface type</i>	<i>Surface designation</i>	<i>Surface</i>	<i>Distance from windward edge</i>	<i>L/B or h/L</i>	$C_p$
Walls	W1	Windward		All	+0.80
	W3, W4	Leeward		1.0	-0.50
	W2, W5	Side		All	-0.70
Roof			0 to $h$	0.15	-0.90*
			$h$ to $2h$	0.15	-0.50*
			$> 2h$	0.15	-0.30*

\*The values of smaller uplift pressures ( $C_p = -0.18$ ) on the roof can become critical when wind load is combined with roof live load or snow load; load combinations are given in Sections 2.3 and 2.4 of the Standard. For brevity, loading for this value is not shown here.

**Table 3-65** External Pressure Coefficients ( $C_p$ ) for Wind Normal to Wall W5

<i>Surface type</i>	<i>Surface designation</i>	<i>Surface</i>	<i>Distance from windward edge</i>	<i>L/B or h/L</i>	$C_p$
Walls	W5	Windward		All	+0.80
	W2, W3	Leeward		1.0	-0.50
	W1, W4	Side		All	-0.70
Roof			0 to $h$	0.15	-0.90
			$h$ to $2h$	0.15	-0.50
			$> 2h$	0.15	-0.30

**Table 3-66** External Pressure Coefficients ( $C_p$ ) for Wind Normal to Wall W4

<i>Surface type</i>	<i>Surface designation</i>	<i>Surface</i>	<i>Distance from windward edge</i>	<i>L/B or h/L</i>	$C_p$
Walls	W4, W3	Windward		All	+0.80
	W1	Leeward		1.0	-0.50
	W2, W5	Side		All	-0.70
Roof			0 to $h$	0.15	-0.90
			$h$ to $2h$	0.15	-0.50
			$> 2h$	0.15	-0.30

**Table 3-67** External Pressure Coefficients ( $C_p$ ) for Wind Normal to Wall W2

<i>Surface type</i>	<i>Surface designation</i>	<i>Surface</i>	<i>Distance from windward edge</i>	<i>L/B or h/L</i>	$C_p$
Walls	W2, W3	Windward		All	+0.80
	W5	Leeward		1.0	-0.50
	W1, W4	Side		All	-0.70
Roof			0 to $h$	0.15	-0.90
			$h$ to $2h$	0.15	-0.50
			$> 2h$	0.15	-0.30

**Design Wind Pressures for the MWFRS**

The design pressures for this building are obtained by the equation

$$p = qGC_p - q_i(GC_{pi}) \quad (\text{Eq. 6-17})$$

where

- $q = q_z = 9.0$  for windward wall at height  $z = 15$  ft and below
- $q = q_h = 9.0$  psf for leeward wall, side walls, and roof
- $q_i = q_h = 9.0$  psf for all surfaces since the building is enclosed
- $G = 0.85$ , the gust effect factor for rigid buildings and structures
- $C_p =$  External pressure coefficient for each surface, as shown in Figure 3-43 of this guide
- $(GC_{pi}) = \pm 0.18$ , the internal pressure coefficient for enclosed buildings

For windward walls:

$$p = q_zGC_p - q_h(GC_{pi}) = 9.0(0.85)C_p - 9.0(\pm 0.18) = 7.7C_p \pm 1.6$$

For all other surfaces:

$$p = q_hGC_p - q_h(GC_{pi}) = 9.0(0.85)C_p - 9.0(\pm 0.18) = 7.7C_p \pm 1.6$$

Design pressures are summarized in Tables 3-68 through 3-71.

The external roof pressures and their prescribed zones are shown in Figure 3-44.

**Table 3-68** Design Pressures for Wind Normal to Wall W1

Surface type	Surface designation	z or x (ft)	q (psf)	$C_p$	External pressure (psf)	Design pressures (psf)	
						$(+GC_{pi})$	$(-GC_{pi})$
Walls	W1	0 to 15	9.0	+0.80	+6.2	+4.6	+7.8
	W3, W4	0 to 15	9.0	-0.50	-3.9	-5.5	-2.3
	W2, W5	0 to 15	9.0	-0.70	-5.4	-7.0	-3.8
Roof		0 to 15	9.0	-0.90	-6.9	-8.5	-5.3
		15 to 30	9.0	-0.50	-3.9	-5.5	-2.3
		30 to 100	9.0	-0.30	-2.3	-3.9	-0.7

Note:  $q_h = 9.0$  psf;  $G = 0.85$ .

**Table 3-69** Design Pressures for Wind Normal to Wall W5

Surface type	Surface designation	z or x (ft)	q (psf)	$C_p$	External pressure (psf)	Design pressures (psf)	
						$(+GC_{pi})$	$(-GC_{pi})$
Walls	W5	0 to 15	9.0	+0.80	+6.2	+4.6	+7.8
	W2, W3	0 to 15	9.0	-0.50	-3.9	-5.5	-2.3
	W1, W4	0 to 15	9.0	-0.70	-5.4	-7.0	-3.8
Roof		0 to 15	9.0	-0.90	-6.9	-8.5	-5.3
		15 to 30	9.0	-0.50	-3.9	-5.5	-2.3
		30 to 100	9.0	-0.30	-2.3	-3.9	-0.7

Note:  $q_h = 9.0$  psf;  $G = 0.85$ .

**Table 3-70** Design Pressures for Wind Normal to Wall W4

Surface type	Surface designation	z or x (ft)	q (psf)	$C_p$	External pressure (psf)	Design pressures (psf)	
						(+GC <sub>pi</sub> )	(-GC <sub>pi</sub> )
Walls	W4, W3	0 to 15	9.0	+0.80	+6.2	+4.6	+7.8
	W1	0 to 15	9.0	-0.50	-3.9	-5.5	-2.3
	W2, W5	0 to 15	9.0	-0.70	-5.4	-7.0	-3.8
Roof		0 to 15	9.0	-0.90	-6.9	-8.5	-5.3
		15 to 30	9.0	-0.50	-3.9	-5.5	-2.3
		30 to 100	9.0	-0.30	-2.3	-3.9	-0.7

Note:  $q_h = 9.0$  psf;  $G = 0.85$ .

**Table 3-71** Design Pressures for Wind Normal to Wall W2

Surface type	Surface designation	z or x (ft)	q (psf)	$C_p$	External pressure (psf)	Design pressures (psf)	
						(+GC <sub>pi</sub> )	(-GC <sub>pi</sub> )
Walls	W2, W3	0 to 15	9.0	+0.80	+6.2	+4.6	+7.8
	W5	0 to 15	9.0	-0.50	-3.9	-5.5	-2.3
	W1, W4	0 to 15	9.0	-0.70	-5.4	-7.0	-3.8
Roof		0 to 15	9.0	-0.90	-6.9	-8.5	-5.3
		15 to 30	9.0	-0.50	-3.9	-5.5	-2.3
		30 to 100	9.0	-0.30	-2.3	-3.9	-0.7

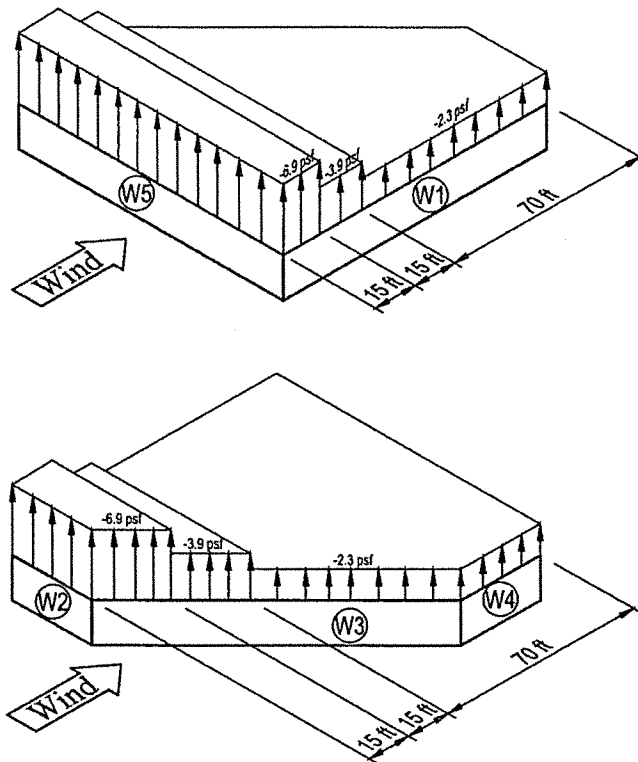
Note:  $q_h = 9.0$  psf;  $G = 0.85$ .

### Minimum Design Wind Pressures

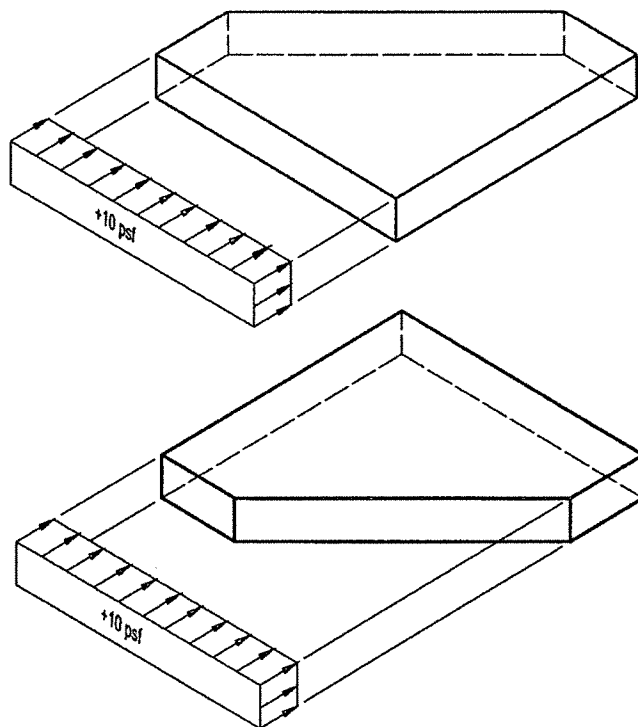
Section 6.1.4.1 of the Standard requires that the MWFRS be designed for not less than 10 psf applied to the projection of the building in each orthogonal direction on a vertical plane. This is checked as a separate load case. The application of this load is shown in Figure 3-45.

### Design Wind Load Cases

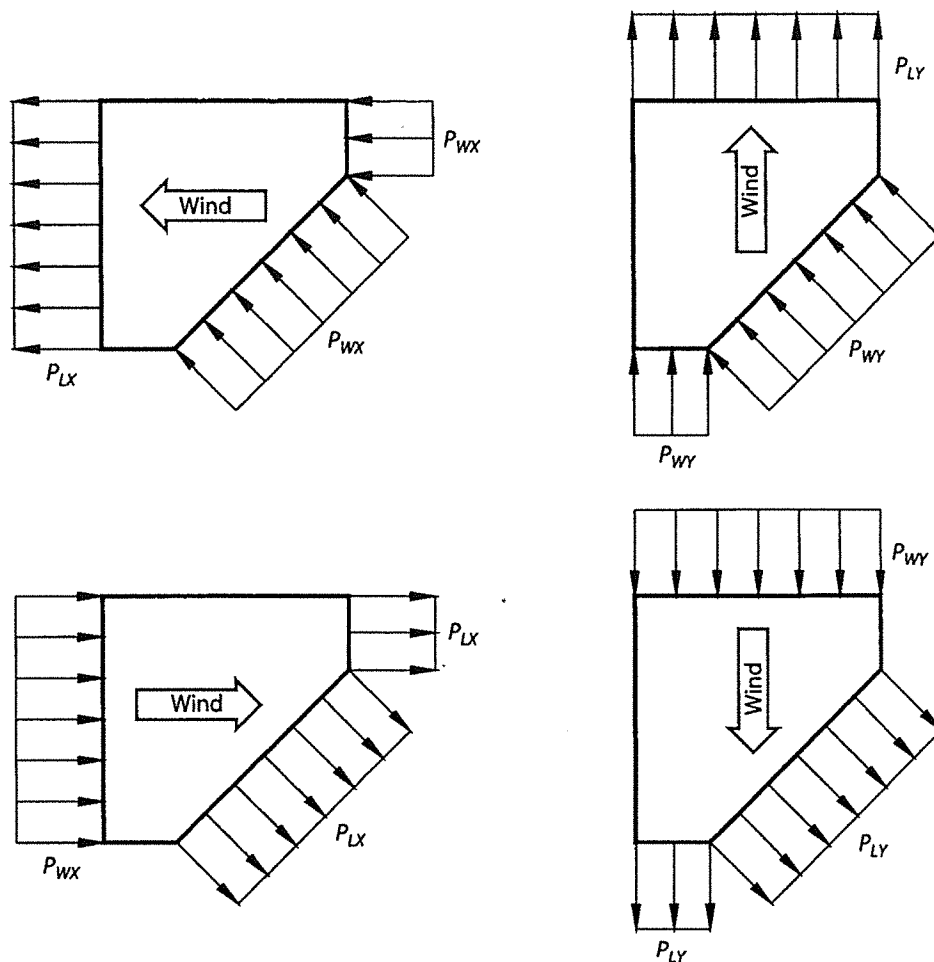
Section 6.5.12.3 of the Standard requires that any building whose wind loads have been determined under the provisions of Sections 6.5.12.2.1 and 6.5.12.2.3 shall be designed for wind load cases as defined in Figure 6-9. There are several exceptions noted that require only the use of Load Case 1, the full orthogonal wind case, and Load Case 3, the diagonal wind case approximated by applying 75% of the loads to adjacent faces simultaneously. The exceptions are building types that are not sensitive to torsional wind effects, which are created by Load Cases 2 and 4. One of these exceptions is for one-story buildings less than 30 ft in height, so this example meets that exception and is required only to meet Load Cases 1 and 3. Load Case 1 is calculated above and shown applied in each orthogonal direction in Figure 3-46. Load Case 3 is the diagonal wind load case, applied in each of four directions as shown in Figure 3-47.



**Figure 3-44** External Roof Pressure Zones for MWFRS



**Figure 3-45** Application of 10-psf Minimum Load Case



**Figure 3-46** Application of Load Case 1 from Each Orthogonal Direction

### Design Pressures for Components and Cladding

Design pressure for components and cladding is obtained by the following equation:

$$p = q_h [(GC_p) - (GC_{pi})] \quad (\text{Eq. 6-22})$$

where

$$q_h = 11.0 \text{ psf for Case 1}$$

$(GC_p)$  = External pressure coefficient (see Figures 6-11A and 6-11B of the Standard)

$(GC_{pi})$  =  $\pm 0.18$ , the internal pressure coefficient for enclosed buildings

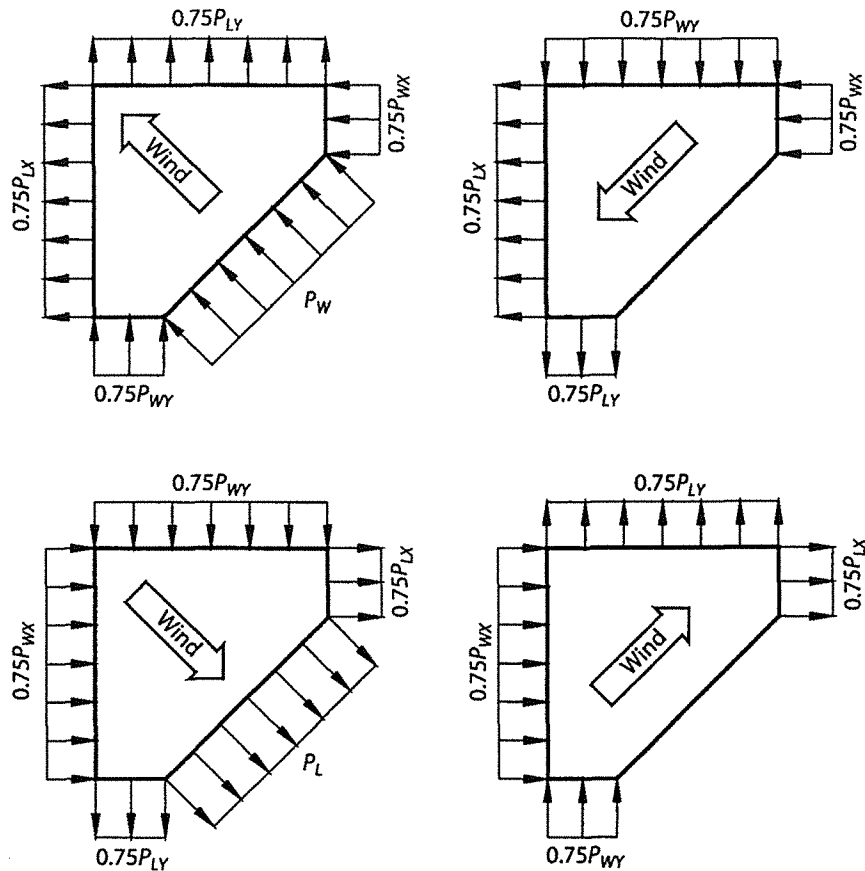
### Wall Design Pressures

The pressure coefficients  $(GC_p)$  are a function of effective wind area. Since specific components of the walls are not identified, pressure coefficients are given for various effective wind areas in Table 3-72. These values have been reduced by 10% as allowed by Note 5 in Figure 6-11A for roof angle  $\theta \leq 10^\circ$ .

Width edge zone:

smaller of

$$a = 0.1(100) = 10 \text{ ft}$$



**Figure 3-47** Application of Load Case 3 from Each Diagonal Direction

**Table 3-72** Wall ( $GC_p$ ) for Ex.12

$A$ ( $ft^2$ )	$GC_p$		
	Zones 4 and 5 ( $+GC_p$ )	Zone 4 ( $-GC_p$ )	Zone 5 ( $-GC_p$ )
$\leq 10$	+0.90	-0.99	-1.26
50	+0.79	-0.88	-1.04
100	+0.74	-0.83	-0.95
>500	+0.63	-0.72	-0.72

Note:  $GC_p$  values have been reduced by 10% since  $\theta \leq 10^\circ$ .

or

$$a = 0.4(15) = 6.0 \text{ ft (controls)}$$

but not less than

$$a = 0.04(100) = 4.0 \text{ ft}$$

or

$$a = 3 \text{ ft}$$

The design pressures are the algebraic sum of external and internal pressures. Controlling negative pressure is obtained with positive internal pressure, and controlling positive pressure is obtained with negative internal pressure. The controlling design pressures are given in Table 3-73.

**Table 3-73** Controlling Design Pressures for Wall Components (psf)

Area	Design pressure (psf)			
	Zone 4		Zone 5	
	Positive	Negative	Positive	Negative
≤ 10	+11.9	-12.9	+11.9	-15.9
50	+10.7	-11.6	+10.7	-13.4
100	+10.1	-11.1	+10.1	-12.4
> 500	+8.9*	-9.9*	+8.9*	-9.9*

\*Section 6.1.4.2 of the Standard requires that C&C pressures be not less than ± 10 psf.

**Table 3-74** Roof External Pressure Coefficients ( $GC_p$ )

A (ft <sup>2</sup> )	External pressure coefficient			
	Positive	Negative		
	Zones 1, 2, 3 $GC_p$	Zone 1 $GC_p$	Zone 2 $-GC_p$	Zone 3 $-GC_p$
10	+0.30	-1.00	-1.80	-2.80
50	+0.23	-0.93	-1.31	-1.61
100	+0.20	-0.90	-1.10	-1.10

**Table 3-75** Roof Design Pressures (psf)

Area	Design pressure (psf)			
	Zones 1, 2, 3	Zone 1	Zone 2	Zone 3
	Positive	Negative	Negative	Negative
10	+5.3*	-13.0	-21.8	-32.8
50	+4.5*	-12.2	-16.4	-19.7
100	+4.2*	-11.9	-14.1	-14.1

\*Section 6.1.4.2 of the Standard requires that C&C pressures be not less than ±10 psf.

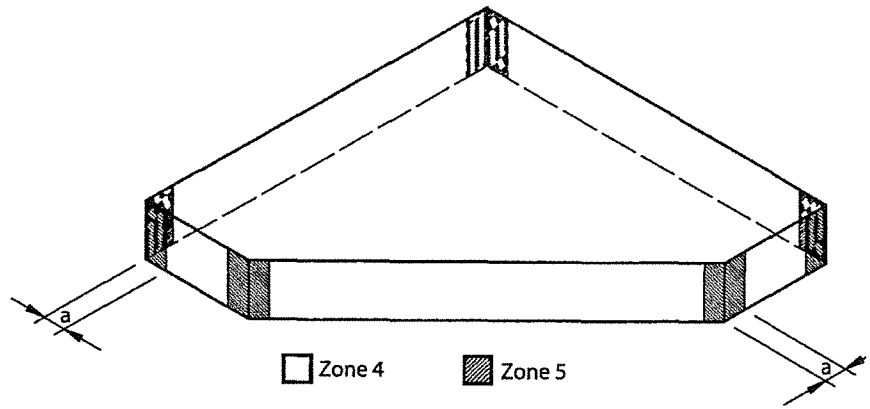
The edge zones for the walls are arranged at exterior corners, as shown in Figure 3-48.

### Roof Design Pressures

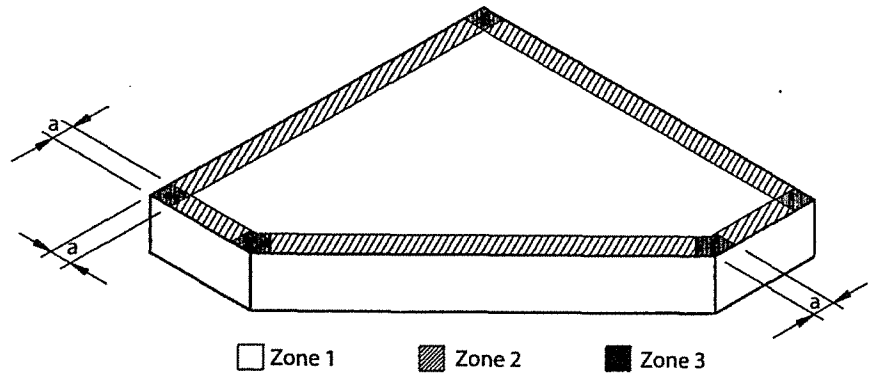
The pressure coefficients ( $GC_p$ ) are a function of effective wind area. Since specific components of the roof are not identified, design pressures are given for various effective wind areas in Table 3-74.

The design pressures (Table 3-75) are the algebraic sum of external and internal pressures. Controlling negative pressure is obtained with positive internal pressure, and controlling positive pressure is obtained with negative internal pressure.

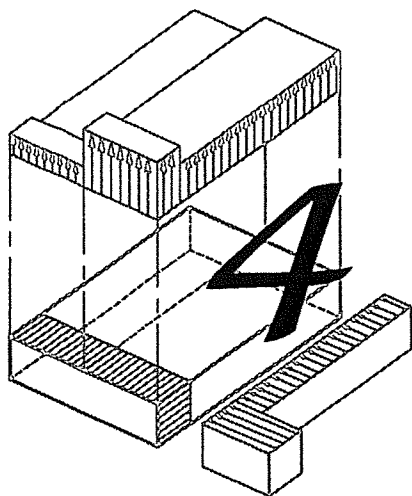
The edge zones for the roof are arranged as shown in Figure 3-49.



**Figure 3-48** Component and Cladding Wall Pressure Zones



**Figure 3-49** Component and Cladding Roof Pressure Zones



# Frequently Asked Questions

Over the last several years, the authors have fielded hundreds of questions and inquiries from users of the ASCE 7 wind load provisions. The purpose of this chapter is to clarify provisions of the Standard about which questions frequently and repeatedly arise.

**1. Is it possible to obtain larger scale maps of basic wind speeds (see Figures 6-1, 6-1a, 6-1b, and 6-1c) so that the locations of the wind speed contours can be determined with greater accuracy?**

No. The wind speed contours in the hurricane-prone region of the United States are based on hurricane wind speeds from Monte Carlo simulations and on estimates of the rate at which hurricane wind speeds attenuate to 90 mph following landfall. Because the wind speed contours of these figures represent a consensus of the ASCE 7 Task Committee on Wind Loads, increasing the map scale would do nothing to improve their accuracy.

**2. IBC Figure 1609 gives the 3-s wind speed at the project location. However, according to the Notes, Figure 1609 is for Exposure C. If the project location is Exposure B, what is the proper wind speed to use?**

Basic wind speed in IBC Figure 1609 or ASCE 7-02 is defined as 3-s gust wind speed at 33 ft above ground for Exposure Category C, which is the standard measurement. The velocity pressure exposure coefficient,  $K_z$ , adjusts the wind speed for exposure and height above ground. However, for simplicity the coefficient is applied in the pressure equation, thus adjusting pressure rather than wind speed. Use of  $K_z$  adjusts the pressures from Exposure C to Exposure B.

**3. If the design wind loads are to be determined for a building that is located in a special wind region (shaded areas) in Figures 6-1, 6-1a, 6-1b, and 6-1c, what basic wind speed should be used?**

The purpose of the special wind regions in these figures is to alert the designer to the fact that there are regions in which wind speed anomalies

are known to exist. Wind speeds in these regions may be substantially higher than the speeds indicated on the map, and the use of regional climatic data and consultations with a wind engineer or meteorologist are advised.

**4. In the design of main wind force-resisting systems (MWFRS), the provisions of Figure 6-6 apply to enclosed or partially enclosed buildings of all heights. The provisions of Figure 6-10 apply to enclosed or partially enclosed buildings with mean roof height less than or equal to 60 ft. Does this mean that either figure may be used for the design of a low-rise MWFRS?**

Figure 6-6 may be used for buildings of all heights, whereas Figure 6-10 applies only to low-rise buildings. Section 6.2 defines low-rise buildings to comply with mean roof height  $h \leq 60$  ft and  $h$  not to exceed least horizontal dimensions. Pressure coefficients for low-rise buildings given in Figure 6-10 represent "pseudo" loading conditions enveloping internal structural reactions of total uplift, total horizontal shear, bending moment, etc. (see Section C6.5.11). Thus, they are not real wind-induced loads. These loads work adequately for buildings of the shapes shown in Figure 6-10; they become questionable when extrapolated to other shapes.

**5. Do I consider a tilt-up wall system to be components and cladding (C&C) or MWFRS or both?**

Both. Depending on the direction of the wind, a tilt-up wall system must resist either MWFRS forces or C&C forces. In the C&C scenario, the elements receive the wind pressure directly and transfer the forces to the MWFRS in the other direction. When a tilt-up wall acts as a shear wall, it is resisting forces of MWFRS. Because the wind is not expected to blow from both directions at the same time, the MWFRS forces and C&C forces are analyzed independently from each other in two different load cases. This is also true of masonry and reinforced-concrete walls.

**6. Section 6.1.4.1 provides for a minimum wind pressure of 10 lb/ft<sup>2</sup> multiplied by the area of the building or structure projected onto a vertical plane normal to the assumed wind direction of MWFRS. Does this provision apply to low-rise buildings?**

It should. There was some confusion in ASCE 7-98 provisions for low-rise buildings where it was difficult to interpret application of loads on building frames using the two cases of loads at each corner. In ASCE 7-02, application of loads on low-rise buildings is clarified with illustrative sketches, and only one table of pressure coefficients is provided (See Figure 6-10 of the standard). In addition, Note 6 is added to account for minimum total horizontal shear, although this provision does not guarantee minimum 10 psf on the projected area of the building.

**7. A tower has a fundamental frequency of 2 Hz, but has a height-to-width ratio of 6. Should the tower be treated as a flexible structure to determine the gust effect factor?**

No. The guideline of height-to-width ratio of 4 or more given in the Commentary is intended to save the user of the Standard the trouble of calculating the fundamental frequency in each and every case. The energy in

the turbulence spectrum is very small for frequencies above 1 Hz. Hence, a tower with fundamental frequency of 2 Hz will not be dynamically excited.

**8. When can I use the one-third stress increase specified in some material standards?**

When using the loads or load combinations specified in ASCE 7-02, no increase in allowable stress is permitted except when the increase is justified by the rate of duration of load (such as duration factors used in wood design). Instead, load combination #6 from Section 2.4.1 of ASCE 7-02 was added for the case when wind load and another transient load are combined. This load combination applies a 0.75 factor to the transient loads ONLY (not to the dead load). The 0.75 factor applied to the transient loads accounts for the fact that it is extremely unlikely that two maximum events will happen at the same time.

**9. Why can the wind directionality factor ( $K_d$ ) only be used with the load combinations specified in Sections 2.3 and 2.4 of ASCE 7-02?**

In the strength design load combinations provided in previous editions of ASCE 7 (ASCE 7-95 and earlier), the 1.3 factor for wind included a "wind directionality factor" of 0.85. In ASCE 7-98, the loading combinations used 1.6 instead of 1.3 (approximately equals  $1.6 \times 0.85$ ), and the directionality factor is included in the equation for velocity pressure. Separating the directionality factor from the load combinations allows the designer to use specific directionality factors for each structure and allows the factor to be revised more readily when new research becomes available.

**10. What exposure category should I use for the MWFRS if the terrain around my site is Exposure B, but there is a large parking lot directly next to one of the elevations?**

Section 6.5.6 of ASCE 7-02 provides general definitions of Exposures B, C, and D; however, the designer must refer to the Commentary for a detailed explanation for each exposure. The exposure depends on the size of the parking lot, its size relative to the building, and the number and type of obstructions in the area. Section C6.5.6 of the Commentary includes a formula (Eq. C6-2) that will help the designer determine if the terrain roughness is sufficient to be categorized as Exposure B. Note that, for Exposure B, the fetch distance is 2,630 ft or 10 times the structure's height, whichever is greater. Also note that the Commentary provides suggestions for determining the "upwind fetch surface area."

For clearings such as parking lots, wide roads, road intersections, underdeveloped lots, and tree clearings, the Commentary provides a rational procedure and an example to interpolate between Exposure B and C; the designer is encouraged to use this procedure.

**11. What pressure coefficients should be used to reflect contributions for the underside (bottom) of the roof overhangs and balconies?**

Sections 6.5.11.4.1 and 6.5.11.4.2 specify pressure coefficients to be used for roof overhangs to determine loads for MWFRS and C&C, respectively. No specific guidance is given for balconies, but use of the loading criteria for roof overhangs should be adequate.

**12. If the mean roof height,  $h$ , is greater than 60 ft with a roof geometry that is other than flat roof, what pressure coefficients are to be used for roof C&C design loads?**

Section 6.5.12.4.3 permits use of pressure coefficients of Figures 6-11 through 6-16 provided the mean roof height  $h < 90$  ft, the height-to-width ratio is 1 or less, and Eq. 6-22 is used.

Note 6 of Figure 6-17 permits use of coefficients of Figure 6-11 when the roof angle  $\theta > 10^\circ$ .

**13. Equation 6-15 for velocity pressure uses the subscript  $z$  while other equations use subscripts  $z$  and  $h$ . When is  $z$  used and when is  $h$  used?**

Equation 6-15 is the general formula for the velocity pressure,  $q_z$ , at any height,  $z$ , above ground. There are many situations in the Standard where a specific value of  $z$  is called for, namely the height (or mean roof height) of a building or other structure. Whenever the subscript  $h$  is called for, it is understood that  $z$  becomes  $h$  in the appropriate equations.

**14. Under what conditions is it necessary to consider speed-up due to topographic effects when calculating wind loads?**

Section 6.5.7 of the Standard requires the calculation of the topographic factor,  $K_{zt}$ , for buildings and other structures sited on the upper half of isolated hills or escarpments located in Exposures B, C, or D where the upwind terrain is free of such topographic features for a distance of at least 100  $H$  or 2 mi, whichever is smaller, as measured from the crest of the topographic feature.  $K_{zt}$  need not be calculated when the height,  $H$ , is less than 15 ft in Exposures D and C, or less than 60 ft in Exposure B. In addition,  $K_{zt}$  need not be calculated when  $H/L_h$  is less than 0.2.  $H$  and  $L_h$  are defined in Figure 6-4. The value of  $K_{zt}$  is never less than 1.0.

**15. What constitutes an open building? If a process plant has a three-story frame with no walls but with a lot of equipment inside the framing, is this an open building?**

An open building is a structure in which each wall is at least 80% open (see Section 6.2). Yes, this three-story frame would be classified as an open building, or as "other" structure. In calculating the wind force,  $F$ , appropriate values of  $C_f$  and  $A_f$  would have to be assigned to the frame and to the equipment inside.

**16. When is a gable truss in a house part of the MWFRS? Should it also be designed as a C&C? What about individual members of a truss?**

Roof trusses are considered to be components since they receive load directly from the cladding. However, since a gable truss receives wind loads from more than one surface, which is part of the definition for MWFRS, an argument can be made that the total load on the truss is more accurately defined by the MWFRS loads. A common approach is to design the members and internal connections of the gable truss for C&C loads, while using the MWFRS loads for the anchorage and reactions. When designing shear walls or cross-bracing, roof loads can be considered an MWFRS.

In the case where the tributary area on any member exceeds 700 ft<sup>2</sup>, Section 6.5.12.1.3 permits it to be considered an MWFRS. Even when considered an MWFRS under this provision, the top chord members of a gable

truss would have to follow rules of C&C if they receive load directly from the roof sheathing.

**17. Flat roof trusses are 30 ft long and are spaced on 4-ft centers. What effective wind area should be used to determine the design pressures for the trusses?**

Roof trusses are classified as C&C since they receive wind load directly from the cladding (roof sheathing). In this case, the effective wind area is the span length multiplied by an effective width that need not be less than one-third the span length or  $(30)(30/3) = 300 \text{ ft}^2$ . This is the area on which the selection of  $GC_p$  should be based. Note, however, that the resulting wind pressure acts on the tributary area of each truss, which is  $(30)(4) = 120 \text{ ft}^2$ .

**18. Roof trusses have a clear span of 70 ft and are spaced 8 ft on center. What effective wind area should be used to determine the design pressures for the trusses?**

Following the approach of question #17, above, the effective wind area is  $(70)(70/3) = 1,633 \text{ ft}^2$ . The tributary area of the truss is  $(70)(8) = 560 \text{ ft}^2$ , which is less than the  $700\text{-ft}^2$  area required by Section 6.5.12.1.3 to qualify for design of the truss using the rules for MWFRS. The truss is to be designed using the rules for C&C, and the wind pressure corresponding to an effective wind area of  $1,633 \text{ ft}^2$  is to be applied to the tributary area of  $560 \text{ ft}^2$ .

**19. Metal decking consisting of panels 20 ft long and 2 ft wide is supported on purlins spaced 5 ft apart. Will the effective wind area be  $40 \text{ ft}^2$  for the determination of pressure coefficients?**

Although the length of a decking panel is 20 ft, the basic span is 5 ft. According to the definition of effective wind area, this area is the span length multiplied by an effective width that need not be less than one-third the span length. This gives a minimum effective wind area of  $(5)(5/3) = 8.3 \text{ ft}^2$ . However, the actual width of a panel is 2 ft, making the effective wind area equal to the tributary area of a single panel, or  $(5)(2) = 10 \text{ ft}^2$ . Therefore,  $GC_p$  would be determined on the basis of  $10 \text{ ft}^2$  of effective wind area, and the corresponding wind load would be applied to a tributary area of  $10 \text{ ft}^2$ . Note that  $GC_p$  is constant for effective wind areas less than  $10 \text{ ft}^2$ .

**20. A masonry wall is 12 ft in height and 80 ft long. It is supported at the top and at the bottom. What effective wind area should be used in determining the design pressure for the wall?**

For a given application, the magnitude of the pressure coefficient,  $GC_p$ , increases with decreasing effective wind area. Therefore, a very conservative approach would be to consider an effective wind area with a span of 12 ft and a width of 1 ft, and design the wall element as C&C. However, the definition of effective wind area states that this area is the span length multiplied by an effective width that need not be less than one-third the span length. Accordingly, the effective wind area would be  $(12)(12/3) = 48 \text{ ft}^2$ .

**21. If a monoslope roof over an open building is virtually flat, what force coefficients from Figure 6-18 should be used?**

A requirement for the use of Figure 6-18 is that the wind shall be assumed to deviate plus or minus  $10^\circ$  from the horizontal. Accordingly, the

values of  $C_f$  corresponding to a roof angle of  $10^\circ$  should be used. The wind forces may be directed either inward or outward, and both cases should be checked.

**22. A trussed tower of  $10 \times 10\text{-ft}^2$  cross section consists of structural angles forming basic tower panels 10 ft high. The solid area of the face of one tower panel projected on a plane of that face is  $22\text{ ft}^2$ . What force coefficient,  $C_f$ , should be used to calculate the wind force? What would the force coefficient be for the same tower fabricated of rounded members and having the same projected solid area? What area should be used to obtain the wind force per foot of tower height acting (1) normal to a tower face, and (2) along a tower diagonal?**

The gross area of one panel face is  $(10)(10) = 100\text{ ft}^2$ , and the solidity ratio is  $\epsilon = 22/100 = 0.22$ . For a tower of square cross section, the force coefficient from Figure 6-22 is as follows:

$$C_f = (4)(0.22)^2 - (5.9)(0.22) + 4.0 = 2.90$$

For rounded members, the force coefficient may be reduced by the factor

$$(0.51)(0.22)^2 + 0.57 = 0.59$$

Thus, the force coefficient for the same tower constructed of rounded members with the same projected area would be

$$C_f = (0.59)(2.90) = 1.71$$

The area,  $A_f$ , used to calculate the wind force per foot of tower height is  $22/10 = 2.2\text{ ft}^2$  for all wind directions.

**23. In calculating the wind forces acting on a trussed tower of square cross section (see Figure 6-22), should the force coefficient,  $C_f$ , be applied to both the front and the back (windward and leeward) faces of the tower?**

No. The calculated wind forces are the total forces acting on the tower. The force coefficients given in Figure 6-22 include the contributions of both front and back faces of the tower, as well as the shielding effect of the front face on the back face.

**24. If the pressure or force coefficients for various roof shapes (e.g., a canopy) are not given in ASCE 7-02, how can the appropriate wind forces be determined for these shapes?**

With the exception of pressure or force coefficients for certain shapes, parameters such as  $V$ ,  $I$ ,  $K_z$ ,  $K_{zt}$ , and  $G$  are given in ASCE 7-02. It is possible to use pressure or force coefficients from the published literature (see Section 1.4 of this guide) provided these coefficients are used with care. Mean pressure or force coefficients from other sources can be used to determine wind loads for MWFRS. However, it should be recognized that these coefficients might have been obtained in wind tunnels that have smooth, uniform flows as opposed to more proper turbulent boundary-layer flows. Pressure coefficients for components and cladding obtained from the literature should be adjusted to the 3-s gust speed, which is the basic wind speed adopted by ASCE 7-02.

**25. Section 6.2 of the Standard provides definitions of glazing, impact resistant; impact-resistant covering; and wind-borne debris regions. To be impact resistant, the Standard specifies that the glazing of the building envelope must be shown by an approved test method to withstand the impact of wind-borne missiles likely to be generated during design winds. Where does one find information on appropriate test methods?**

Section 6.7 of the Standard refers to two ASTM standards. These standards give test method and performance criteria of glazing, doors, and shutters when impacted by wind-borne debris.

**26. The Standard does not provide for across-wind excitation caused by vortex shedding. How can one determine when vortex shedding might become a problem?**

Vortex shedding is almost always present with bluff-shaped cylindrical bodies. Vortex shedding can become a problem when the frequency of shedding is close to or equal to the frequency of the first or second transverse of the structure. The intensity of excitation increases with aspect ratio (height-to-width or length-to-breadth) and decreases with increasing structural damping. Structures with low damping and with aspect ratios of 8 or more may be prone to damaging vortex excitation. If across-wind or torsional excitation appears to be a possibility, expert advice should be obtained.

**27. If high winds are accompanied by rain, will the presence of raindrops increase the mean density of the air to the point where the wind loads are affected?**

No. Although raindrops will increase the mean density of the air, the increase is small and may be neglected. For example, if the average rate of rainfall is 5 in./h, the average density of raindrops will increase the mean air density by less than 1%.

**28. How do I design for a Category 3 hurricane?**

The Saffir/Simpson Hurricane Scale classifies hurricanes based on intensity and damage potential using five categories (1 through 5, with 5 being the most intense). No direct correlation can be made between the Saffir/Simpson Hurricane Scale and design wind speeds. The Saffir/Simpson Hurricane Scale categorizes hurricanes based on 1-min sustained wind speeds, which conform to the National Weather Service requirements. These classifications are intended to be used by emergency management personnel. ASCE 7-93 and previous editions are based on the fastest-mile speeds and ASCE 7-95 and subsequent editions use 3-s gust wind speeds. Figure C6-2 of the Standard may be used to convert 1-min wind speed to 3-s gust wind speed; design using Category 3 hurricane wind speed is likely to be higher than basic wind speed in most areas.

**29. What wind loads do I use during construction?**

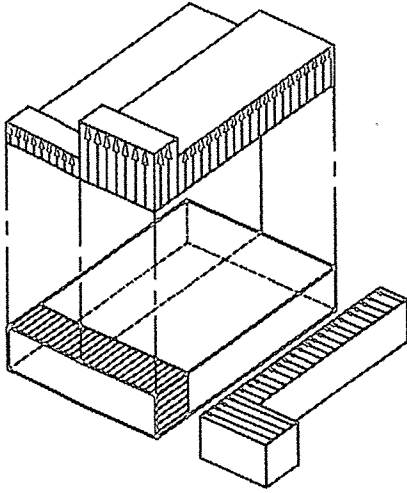
ASCE 7 does not address wind loads during construction. Construction loads are specifically addressed in the standard SEI/ASCE 37-01, *Design Loads on Structures during Construction*.

**30. Can the pressure/force coefficients given in ASCE 7-02 be used with the provisions of ASCE 7-88, 7-93, 7-95, or 7-98?**

Yes, in a limited way. ASCE 7-88 (and 7-93) used the fastest-mile wind speed as the basic wind speed. With the adoption of the 3-s gust speed starting with ASCE 7-95, the values of certain parameters used in the determination of wind forces have been changed accordingly. The provisions of ASCE 7-88 and 7-02 should not be interchanged. Coefficients in ASCE 7-95, 7-98, and 7-02 are consistent; they are related to 3-s gust speed.

**31. Is it possible to determine the wind loads for the design of interior walls?**

The Standard does not address the wind loads to be used in the design of interior walls or partitions. A conservative approach would be to apply the internal pressure coefficients  $GC_{pi} = \pm 0.18$  for enclosed buildings and  $GC_{pi} = \pm 0.55$  for partially enclosed buildings. Post-disaster surveys have revealed the failure of interior walls when the building envelope has been breached.



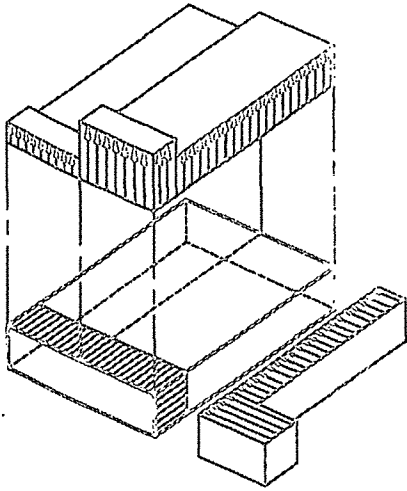
# References

- Akins, R.E., and Cermak, J.E. (1975). "Wind pressures on buildings." *Technical Report CER7677REA-JEC15*, Fluid Dynamics and Diffusion Lab., Colorado State Univ., Fort Collins, Colo.
- ANSI (1982). "Minimum design loads for buildings and other structures." *ANSI A58.1-1982*, New York.
- ANSI/EIA/TIA (1991). "Structural standards for steel antenna towers and antenna supporting structures." *ANSI/EIA/TIA-222-E*. Electronic Industries Assn., Washington, D.C.
- ASCE (1961). "Wind forces on structures." *Transactions*, 126(2), 1124-1198.
- ASCE (1997). *Wind loads and anchor bolt design for petrochemical facilities*. Report from the Committee on Wind Induced Forces and Anchor Bolt Design, Reston, Va.
- ASCE (1999). "Wind tunnel studies of buildings and structures," J.E. Cermak and N. Isyumov, eds. *ASCE Manuals and Reports on Engrg. Practice No. 67*, Reston, Va.
- ASCE (1990). "Minimum design loads for buildings and other structures." *ASCE/ANSI 7-88*, New York.
- ASCE (1996). Minimum design loads for buildings and other structures. *ASCE/ANSI 7-95*, Reston, Va.
- ASCE (2000). Minimum design loads for buildings and other structures. *ASCE 7-98*, Reston, Va.
- Standards Australia (1989). "Australian standard SAA loading code part 2, wind loads." *AS-1170.2*, Sydney.
- AS/NZS (2002). "Australian/New Zealand structural design – general requirements and design actions part 2: wind actions." *AS/NZS 1170.2*, Standards Australia, Sydney.
- ASTM (1997). "Standard test method for performance of exterior windows, curtain walls, doors and storm shutters impacted by missile(s) and exposed to cyclic pressure differentials." *ASTM E1886-97*, West Conshohoken, Pa.
- ASTM (1996). "Standard specification for performance of exterior windows, curtain walls, doors and storm shutters impacted by windborne debris in hurricanes." *ASTM E1996-01*, West Conshohoken, Pa.
- Batts, M.E., Cordes, M.R., Russell, L.R., Shaver, J.R., and Simiu, E. (1980). "Hurricane wind speeds in the United States." *NBS Building Science Series 124*, National Bureau of Standards, Washington, DC.

- Behr, R.A., and Minor, J.E. (1994). "A survey of glazing system behavior in multi-story buildings during Hurricane Andrew." *The Structural Design of Tall Buildings*, 3, 143-161.
- Best, R.J., and Holmes, J.D. (1978). "Model study of wind pressures on an isolated single-story house." *Wind Engrg. Report 3/78*, James Cook Univ. of North Queensland, Australia.
- British Standards Institute (1995). "Loading for buildings, part 2: code of practice for wind loads." *BS 6399*, British Standards Institute, London.
- Cermak, J.E. (1977). "Wind-tunnel testing of structures." *J. Engrg. Mech. Div.*, 103(6), 1125-1140.
- Cook, N.J. (1985). *The designer's guide to wind loading of building structures*, parts I and II. Butterworth Publishers, London.
- Davenport, A.G., Surry, D., and Stathopoulos, T. (1977). "Wind loads on low-rise buildings." *Final report on phases I and II, BLWT-SS8*, Univ. of Western Ontario.
- Davenport, A.G., Surry, D., and Stathopoulos, T. (1978). "Wind loads on low-rise buildings." *Final report on phase III, BLWT-SS4*, Univ. of Western Ontario.
- Durst, C.S. (1960). "Wind speeds over short periods of time." *Meteorological Magazine*, 89, 181-187.
- Eaton, K.J., and Mayne, J.R. (1975). "The measurement of wind pressures on two-story houses at Aylesbury." *J. Industrial Aerodynamics*, 1(1), 67-109.
- EUROCODE 1 (1994). "Basis of design and actions on structures/wind action, part 2.4: wind actions." *CEN/TC 250/SCI*, Technical Secretariat. Brussels.
- FEMA (1980). "Interim guidelines for building occupant protection from tornadoes and extreme winds." *FEMA TR83-A*, Washington, D.C.
- FEMA (1999). "Taking shelter from the storm: building a safer room inside your home." *Publication 320*, Washington, D.C.
- FEMA (2000). "Design and construction guidance for community shelters." *Publication 361*, Washington, D.C.
- Georgiou, P.N., Davenport, A.G., and Vickery, B.J. (1983). "Design wind speeds in regions dominated by tropical cyclones." *J. Wind Engrg. and Industrial Aerodynamics*, 13, 139-152.
- Ho, E. (1992). "Variability of low building wind loads." Ph.D. thesis, Univ. of Western Ontario.
- Holmes, J.D. (2001). *Wind loading of structures*. Spon Press, New York.
- Holmes, J.D., Melbourne, W.H., and Walker, G.R. (1990). "A commentary on the Australian standard for wind loads." Australian Wind Engrg. Society.
- Hoerner, S.F. (1965). *Fluid dynamics drag*. Pub. by S.F. Hoerner, Midland Park, N.J.
- ISO (1997). "Wind actions on structures." *ISO 4354*, International Standards Org., Geneva.
- Isyumov, N. (1982). "The aeroelastic modeling of tall buildings." *Proceedings, international workshop on wind tunnel modeling criteria and techniques in civil engrg. applications*, NBS, Gaithersburg, Md. Cambridge Univ. Press, 373-407.
- Isyumov, N., and Case, P. (1995). "Evaluation of structural wind loads for low-rise buildings contained in ASCE Standard 7-95." *BLWT-SS17-1995*, Univ. of Western Ontario.
- Jackson, P.S. and Hunt, J.C.R. (1975). "Turbulent wind flow over a low hill." *Qtrly. J. Royal Meteorological Society*, 101, 929-955.
- Kareem, A. (1992). "Dynamic response of high-rise buildings to stochastic wind loads." *J. Wind Engrg. and Industrial Aerodynamics*, 41-44.
- Kareem, A. (1985). "Lateral-torsional motion of tall buildings to wind loads." *J. Struct. Engrg.*, 111(11).
- Kareem, A., and Smith, C. (1993). "Performance of offshore platforms in Hurricane Andrew." *Proceedings, Hurricanes of 1992*, Dec. 1-3, Miami, Fla. ASCE.

- Kavanagh, K.T., Surry, D., Stathopoulos, T., and Davenport, A.G. (1983). "Wind loads on low-rise buildings: phase IV." *BLWT-SS14*, Univ. of Western Ontario.
- Krayer, W.R., and Marshall, R.D. (1992). "Gust factors applied to hurricane winds." *Bull. American Meteorological Society*, 73, 613-617.
- Lawson, T.V. (1980). *Wind effects on buildings*, vol. 1 and 2. Applied Science Publishers Ltd., Essex, England.
- Lemelin, D.R., Surry, D., and Davenport, A.G. (1988). "Simple approximations for wind speed-up over hills." *J. Wind Engrg. and Industrial Aerodynamics*, 28, 117-127.
- Liu, Henry (1991). *Wind engineering: a handbook for structural engineers*, Prentice-Hall, New York.
- Marshall, R.D., and Yokel, F.Y. (1995). "Recommended performance-based criteria for the design of manufactured home foundation systems to resist wind and seismic loads." *NISTIR 5664*, NIST, Gaithersburg, Md.
- McDonald, J.R. (1983). "A methodology for tornado hazard probability assessment." *NUREG/CR3058*, U.S. Nuclear Regulatory Comm., Washington, D.C.
- Mehta, K.C. and Marshall, R.D. (1998). *Guide to the Use of the Wind Load Provisions of ASCE 7-95*. ASCE, Reston, Va.
- Mehta, K.C. and Perry, D.C (2000). *Guide to the Use of the Wind Load Provisions of ASCE 7-98*. ASCE, Reston, Va.
- Miami/Dade County Building Code Compliance Office. "Impact test procedures." *Protocol PA 201-94*.
- Miami/Dade County Building Code Compliance Office. "Criteria for testing products subject to cyclic wind pressure loading." *Protocol PA 203-94*.
- Minor, J.E. (1982). "Tornado technology and professional practice." *J. Struct. Div.*, 108(11), 2411-2422.
- Minor, J.E., and Behr, R.A. (1993). "Improving the performance of architectural glazing systems in hurricanes." *Proceedings, Hurricanes of 1992*, Dec. 1-3, Miami, Fla., pp. C1-11. ASCE.
- Minor, J.E., McDonald, J.R., and Mehta, K.C. (1993). "The tornado: an engineering oriented perspective." *NOAA Technical Memorandum, National Weather Service SR-147* (Reprint of Technical Memorandum ERL NSSL-82), National Oceanic and Atmospheric Admin.
- Murray, R.C., and McDonald, J.R. (1993). "Design for containment of hazardous materials." *Geophysical Monograph 79: The tornado: its structure, dynamics, prediction and hazards*, C. Church, D. Burgess, C. Doswell, and R. Davies-Jones, eds. American Geophysical Union, 379-387.
- Newberry, C.W., and Eaton, K.J. (1974). "Wind loading handbook." *Building Research Establishment Report K4F*. Her Majesty's Stationery Office, London.
- NRCC (1995a). *National building code of Canada, 1995*. Assoc. Committee on the National Building Code of Canada, National Research Council of Canada.
- NRCC (1995b). *Supplement to the national building code of Canada, 1995*. Assoc. Committee on the National Building Code of Canada, National Research Council of Canada.
- Peterka, J.A. (1992). "Improved extreme wind prediction for the United States." *J. Wind Engrg. and Industrial Aerodynamics*, 41, 533-541.
- Peterka, J.A., and Cermak, J.E. (1974). "Wind pressures on buildings—probability densities." *J. Struct. Div.*, 101(6), 1255-1267.
- Peterka, J.A., and Shahid, S. (1993). "Extreme gust wind speeds in the U.S." *Proceedings, 7th U.S. national conference on wind engineering*, UCLA, Los Angeles, 503-512.
- Reinhold, T.A., ed. (1982). "Wind tunnel modeling for civil engineering applications." *Proceedings, international workshop on wind tunnel modeling criteria and techniques in civil engineering applications*, NBS, Gaithersburg, Md. Cambridge Univ. Press.

- SAA (1989). *Australian standard SAA loading code, part 2: wind loads*. Standards Australia, Sydney.
- Saathoff, P., and Stathopoulos, T. (1992). "Wind loads on buildings with sawtooth roofs." *J. Struct. Engrg.*, 118(2), 429-446.
- SBCCI. (1999). *SBCCI Test Standard for Determining Impact Resistance from Windborne Debris*. SSTD 12-99, Southern Building Code Congress International, Birmingham, AL, 1999.
- Simiu, E. (1981). "Modern developments in wind engineering: part 1-4." *Engrg. Structures*, 3.
- Simiu, E., and Scanlan, R.H. (1996). *Wind effects on structures*, 3d Ed., Wiley, New York.
- Solari, G. (1993). "Gust buffeting I: peak wind velocity and equivalent pressure." *J. Struct. Engrg.*, 119(2).
- Solari, G. (1993). "Gust buffeting II: dynamic along-wind response." *J. Struct. Engrg.*, 119(2).
- Stathopoulos, T. (1981). "Wind loads on eaves of low buildings." *J. Struct. Engrg. Div.*, 107(10), 1921-1934.
- Stathopoulos, T., and Dumitrescu-Brulotte, M. (1989). "Design recommendations for wind loading on buildings of intermediate height." *Canadian J. Civil Engrg.*, 16(6), 910-916.
- Stathopoulos, T., and Luchian, H.D. (1990). "Wind pressures on building configurations with stepped roofs." *Canadian J. Civil Engrg.*, 17(4), 569-577.
- Stathopoulos, T., and Mohammadian, A.R. (1986). "Wind loads on low buildings with mono-sloped roofs." *J. Wind Engrg. and Industrial Aerodynamics*, 23, 81-97.
- Stathopoulos, T., and Saathoff, P. (1991). "Wind pressures on roofs of various geometries." *J. Wind Engrg. and Industrial Aerodynamics*, 38, 273-284.
- Surry, D., and Stathopoulos, T. (1988). "The wind loading of buildings with monoslope roofs." *Final report, BLWT-SS38*, Univ. of Western Ontario.
- TDI. (1998). "Test for impact and cyclic wind pressure resistance of impact protective systems and exterior opening systems," Appendix E. *Building Code for Wind-storm Resistant Construction, TDI Standard 1-98*, Texas Dept. of Insurance, Austin.
- Vickery, P.J., and Twisdale, L.S. (1993). "Prediction of hurricane wind speeds in the U.S." *Proceedings, 7th U.S. national conference on wind engineering*, UCLA, Los Angeles, 823-832.
- Walmsley, J.L., Taylor, P.A., and Keith, T. (1986). "A simple model of neutrally stratified boundary-layer flow over complex terrain with surface roughness modulations." *Boundary-Layer Meteorology*, 36, 157-186.
- Wen, Y.K., and Chu, S.L. (1973). "Tornado risks and design wind speed." *J. Struct. Div.*, 99(12), 2409-2421.
- Yeatts, B.B., and Mehta, K.C. (1993). "Field study of internal pressures." *Proceedings, 7th U.S. national conference on wind engineering*, UCLA, Los Angeles, 889-897.
- Yeatts, B.B., Womble, J.A., Mehta, K.C., and Cermak, J.E. (1994). "Internal pressures for low-rise buildings." *Proceedings, second U.K. conference on wind engineering*, Warwick, England.



# Index

- across-wind response 92, 116
- allowable stress, increase in 112
- analytical procedure 6-7, 8-10, 18, 27, 48, 66-67, 93, 100-109
- apartment building 78-88
- ASCE 7-02 1; changes in 2-3; limitations of 3-4
  
- balconies 112
- basic wind speed 19, 24, 27, 37, 48, 59, 67, 79, 88, 94, 101; maps 110
- billboard signs 88-93
- building category II 19, 24, 27, 27, 37, 47, 59, 66, 100
- building category III 94
- building surfaces, pressures on 62
  
- C&C. *See* components and cladding
- cladding 6
- commercial buildings 18-23, 66-77
- components and cladding 1, 25-26; design pressure 9-10, 21, 25-26, 32, 45-47, 64, 71-72, 83, 98, 106-109; force on 92; roof pressure zones 88, 109; roofs 53, 56-57, 77; wall pressure zones 87, 109; walls 52-56. *See also* cladding
- construction, wind loads during 116
  
- design force 92
- design pressures 49; calculation of 8, 34-35, 86
- design wind load 21, 97-98, 104; combined 32, 52, 83; open buildings 10
- design wind pressures, components and cladding 25-26
- design wind pressures, MWFRS 19-21; 24-25, 28, 60-61; longitudinal direction 61; minimum 104; transverse direction 61
- diagonal direction 107
- domed roof, design wind pressure 98-98
- domed roof building 93-99
  
- effective velocity pressure 9
- effective wind area 26, 83

escarpments 37; topographic effect 38–39  
exposure adjustment coefficient 24  
exposure category, determining 112  
exposure category B 27, 37, 66, 79, 100, 110  
exposure category C 19, 24, 47, 59, 88, 93, 110  
external pressure 83–86; roofs 87  
external pressure coefficients 29, 31, 60, 80–81, 101–102

fasteners 47  
fastest-mile wind speed 117  
flat roofs 24, 114  
flexible structures 88–93  
force coefficient 90

gable roofs 11, 12, 39–47, 47–58; multispans 13  
gable truss 113–114  
glazing, impact resistant 19, 116  
glazing panels 27, 37  
gust effect 8, 9, 19, 28–29, 41, 49, 68, 90–92

height adjustment coefficient 24  
height-to-width ratio 111–112; roofs 113  
high-rise buildings 26–36  
hip roofs 12, 39–47  
house, one-story 39–47  
hurricane prone area 19, 30  
hurricane wind speeds 110, 116

interior walls 117  
internal pressure 9  
internal pressure calculation 31  
internal pressure coefficients 19, 30–31, 60, 62–63; domed roofs 96–97

joist pressures 76–77

leeward pressure 7, 29  
leeward wall, pressures on 69–70  
loading cases 62–63  
longitudinal direction 61, 63–64  
low-rise buildings 9, 59–65, 111

main wind force-resisting systems (MWFRS) 2, 6, 33, 34, 53; axial load 58; building height 111; calculation of 69–70; combined 73–74; design force 90; design pressure 60, 67–68, 71, 72; design wind pressure 19–21, 24–25, 28, 41, 82, 95–97, 103; external pressures 31, 97, 105; net pressure 50–52, 54  
masonry buildings 18–23  
masonry walls 114  
metal decking 114  
Method 1. *See* simplified procedure  
Method 2. *See* analytical procedure  
Method 3. *See* wind tunnel procedure  
minimum load case, application of 105

monoslope roofs 14, 66–77, 114–115  
mullions 32; design pressure 35  
multispan gabled roofs 13  
MWFRS. *See* main wind force-resisting systems (MWFRS)

non-symmetrical buildings 4, 78–88, 100–109

office buildings 37–39, 113  
open buildings, design wind force 10  
open terrain 93  
orthogonal direction 106  
overhang pressure 42–44  
overhangs 66, 112; pressures on 69

panels, design pressure 35  
parapet, design pressure 35–36  
parapet load 32  
publications. *See* technical literature

rain 116  
reinforced concrete rigid frame 26, 37  
rigid buildings 18–23; design pressure 9–10  
rigid frame structure 26, 47, 59  
roof components 46; pressure 57  
roof design pressure 36, 75–77, 87–88, 99, 108  
roof external pressure 36, 41–44, 68, 69, 99, 108  
roof height-to-width ratio 113  
roof joist pressures 22–23, 26  
roof panels 46  
roof pressure coefficient 20, 29–30, 51–52, 56  
roof pressure zones 88, 105  
roof pressures 96  
roof shapes 115  
roof slope 69, 74  
roof trusses 114  
roofs 11–16; design pressure 36

Saffir/Simpson Hurricane Scale 116  
sawtooth roofs 15  
simplified procedure 2, 6, 7–8, 24–26, 78  
special structures 3  
special wind regions 110–111  
speed-up 113  
steel framed structure 18, 66, 93, 100  
storm shelters 3  
structural response, evaluating, limitations in 3–4  
structural shapes 4  
strut purlins 57–58

tabulated wind pressure values 7–8  
technical literature 4–5  
tilt-up wall system 111

timber frame structure 39, 78  
topographic effects 113  
tornado winds 3  
torsional loads 62–65  
towers 111, 115  
transverse direction 61  
transverse directional loads 62–64  
trussed towers 115

uplift pressure 20  
U-shaped buildings 78–88

velocity pressure 19, 27–28, 38–39, 48–49, 67, 79, 89, 94–95, 101; design procedure  
6–7; formulas for 113; uniformly distributed 59–60  
vortex shedding 4, 92, 116

wall coefficients 54  
wall components 45, 55  
wall design pressure 32, 72, 75, 83–86, 98, 103–104, 106, 107; controlling 86,  
107–108  
wall external pressure coefficients 29, 68, 69, 74, 80–81, 102  
wall pressures 21–22, 25, 29, 95; coefficient 20, 34; main wind force-resisting  
systems (MWFRS) 41–44; zones 87  
wall studs 45  
walls 11, 16, 49–50; concrete masonry unit 18, 21–22, 25, 66, 72  
warehouse building 47–58  
wind climate, assessment of 3  
wind direction 41–44, 48, 61, 112; combinations 44–45  
wind tunnel procedure 6, 10  
windward pressure 7, 29