

CHAPTER 43

BUILDING ENVELOPES

[Single-Family Residences](#)..... 43.1
[Fenestration](#)..... 43.6
[Wall/Roof Interface](#) 43.7
[Thermal Bridges in Buildings](#) 43.8
[Thermal Mass](#)..... 43.11

BUILDINGS are designed and constructed to provide shelter from the weather and typically to provide conditioned space for the intended occupancy, whether it be residential, office, medical, museum, manufacturing, etc. During design, fundamental decisions are made about the foundation, walls, roof, selection of windows and doors, and the HVAC system.

The **building envelope** consists of those parts of the building that separate the controlled indoor environment from the uncontrolled outdoor environment. It typically includes the **foundation, floors, walls, fenestration** (windows and doors), and **roof**. To make good decisions, the designer must take into account design climate factors such as winter temperature, summer temperature and relative humidity, wind speed, peak and annual rainfall, and seismic zone.

The building envelope should (Hutcheon 1963)

- Control
 - Heat flow
 - Airflow
 - Water vapor flow
 - Rain penetration
 - Light, solar, and other radiation
 - Noise
 - Fire
- Provide strength and rigidity
- Be durable
- Be aesthetically pleasing
- Be economical

Although the overall design of the building envelope is normally the project architect’s responsibility, many of these performance requirements are addressed by consulting engineers. Control of heat, airflow, and moisture arise from the building envelope’s function of separating the controlled indoor environment from the uncontrolled outdoor environment. As a consequence, the HVAC designer should be knowledgeable about the interdependency between the building envelope and HVAC system; review the envelope’s heat, air, and moisture control characteristics; and provide knowledgeable input to the design team if the functional program for the building environment is incompatible with the performance of the building envelope as designed.

This chapter applies information from Chapters 23 to 25 of the 2005 *ASHRAE Handbook—Fundamentals* to building envelope design. It separately addresses single-family residential buildings, which are usually designed using a prescriptive approach, and institutional, commercial, and industrial buildings, which are designed by a team consisting of the owner, architect, and consulting engineers.

The preparation of this chapter is assigned to TC 4.4, Building Materials and Building Envelope Performance.

SINGLE-FAMILY RESIDENCES

Foundations and Floors

Foundation design for single-family residences entails not only structural soundness, but also appropriate energy, moisture, radon, and radon control. In North America, several building energy codes recommend foundation insulation in climates with more than 2500 heating degree-days (base 65°F). An uninsulated, conditioned basement may lose up to 20% of the heat in a tightly sealed house that is well insulated above grade.

Although saving energy is an important incentive, insulating basements also creates a more comfortable, livable space at a relatively low cost. Raising basement temperatures in cold climates reduces condensation, minimizes problems with mold and mildew, and helps maintain acceptable indoor air quality.

Construction. The three basic types of foundations are basement, crawlspace, and slab-on-grade. Each requires specific attention to details of environmental separation. The cost of higher insulation levels can be compared with the savings in several ways, but a life-cycle cost analysis is the best method (Carmody et al. 1991). It takes into account a number of economic variables, including installation costs, mortgage rates, HVAC efficiencies, and energy costs.

Conditioned Basements. A concrete or masonry basement wall may be insulated by (1) insulating the exterior upper half, (2) insulating the entire exterior wall, or (3) insulating the entire interior wall.

Crawlspace. A crawlspace can be designed as a short basement (with a floor). Because the floor is above grade, it is less subject to moisture hazards than a slab floor. However, if moisture problems occur, they are more likely to be noticed in a basement because it is more accessible than a crawlspace. Although most codes require operable louvered vents (1 ft² per 1500 ft²) near each corner of a crawlspace, research has shown that moisture-retardant ground cover is more effective and, in most locations, eliminates the need for vents (ASHRAE 1994).

In an unconditioned crawlspace, insulation is placed between the floor joists. In an unvented crawlspace, either the concrete or masonry walls or the floor above can be insulated. If the walls are insulated, air infiltration paths such as the interface between the crawlspace wall and bottom plate of the floor above must be sealed. Intersections of two hard surfaces are common air infiltration paths. Walls may be insulated on the (1) entire exterior wall, (2) entire interior wall, or (3) entire interior wall and perimeter of the crawlspace floor to a depth of 2 ft. When the floor is insulated, appropriate ground cover must be installed to control moisture in the crawlspace and to prevent high moisture levels from degrading the thermal performance of the insulation. In pressure-treated wood construction, insulation is placed in the cavities between the wood studs.

The disadvantages of a vented crawlspace are that (1) pipes and ducts must be insulated; (2) a larger area must be insulated (the floor area is greater than the wall area), which may increase the cost; and (3) in some climates, warm, humid air circulating in the crawlspace can cause the wood to have an excessive moisture content. However,

vented crawlspaces are often provided with operable vents that can be closed to reduce winter heat losses (closing them may, however, increase radon levels). Also, these vents can be closed in summer to keep out moist exterior air that may have a dew point above the crawlspace temperature. However, unless steps are taken to control air infiltration, closing vents does not ensure that the crawlspace has no air exchange with the outside; any exchange with outside air reduces thermal performance.

There are several advantages to designing crawlspaces as unvented, semiconditioned zones. Duct and pipe insulation can be reduced, and insulating the foundation at the perimeter instead of the floor above requires less insulation, simplifies installation, and minimizes condensation. Although increased airflow by venting can dilute ground-source moisture and radon, complementing control measures such as ground covers and proper drainage, it will not eliminate them. Venting crawlspaces may be desirable in areas of high radon hazard, but it should not be considered a reliable radon mitigation strategy. Depressurizing the crawlspace is effective at minimizing soil gas uptake. In flood-prone areas, vents may serve the additional function of hydrostatic equalization across the foundation, and unvented crawlspaces may be impractical to construct.

Slab-on-Grade. For slab-on-grade foundations with concrete or masonry walls, insulation is usually placed on the entire exterior surface of the foundation stem wall, on the interior surface of the foundation wall, or horizontally under the slab perimeter. When the insulation is placed on the interior, it is important to place it in the joint between the slab edge and the foundation wall.

Another method is to place insulation horizontally on the building exterior extending 2 to 4 ft into the surrounding soil. Shallow footings (less than 2 ft below grade) or slabs with a thickened edge and no foundation wall are common in some regions. In these cases, additional insulation may be placed horizontally along the exterior edge.

Thermal Performance. A key question in foundation design is whether to place insulation inside or outside the basement or crawlspace wall. Placing rigid insulation on the **exterior** of a concrete or masonry basement or crawlspace wall has some advantages: it provides continuity without thermal bridges, keeps the waterproofing and structural wall at moderate temperatures, minimizes moisture condensation problems, does not reduce interior basement floor area, and includes the foundation in the building thermal mass. Exterior insulation at the rim joist leaves joists and sills open for inspection from the interior for termites and decay.

However, exterior insulation can provide a path for termites and can prevent inspection of the wall from the outside. A termite shield may need to be installed through the insulation where the sill plate rests on the foundation wall. Vertical, exterior insulation can extend as deep as the top of the footing and can be supplemented by extending insulation horizontally from the face of the foundation wall.

Interior insulation is an effective alternative, and it is generally less expensive if the costs of interior finish materials, including a flame spread cover, are not included. However, interior wall insulation increases the exposure of the wall to thermal stress and freezing and may increase the likelihood of condensation on sill plates, band joists, and joist ends.

In a wood foundation, insulation is placed between studs. Insulation placed around the crawlspace floor perimeter can provide additional thermal protection; however, it may also create additional paths for termite entry. A 2 in. air space between the lower end of the insulation in a crawlspace or wall cavity and the bottom plate of the foundation wall allows inspection for insect infestation. Batt or tight-fitting rigid foam board insulation is commonly placed inside the rim joist.

In a foundation system of wood pressure-treated with preservative, insulation is placed in the stud cavities as for above-grade insulation in a wood frame wall. Crawlspace walls may also be insulated by spraying insulating foam.

Insulation may also be incorporated in concrete or masonry walls. Examples include rigid foam plastic insulation cast within the concrete wall; formed interlocking rigid foam units that serve as a permanent, insulating form for cast-in-place concrete; and masonry blocks made with polystyrene beads or a low-density aggregate/regular-density concrete mixture. However, the effectiveness of construction that insulates only a portion of the wall area should be evaluated closely because thermal bridges can significantly reduce the insulation's effectiveness.

For **slab-on-grade systems**, the greatest heat loss is through the small area of the foundation wall above grade. Heat is also lost from the slab to the soil. Heat losses to the soil are greatest at the slab edge and diminish rapidly with depth. Slab heat loss both at the edge and through the soil must be considered in designing the insulation system.

Insulation can be placed vertically outside the foundation wall or grade beam. This approach effectively insulates the exposed slab edge above grade and extends downward to reduce heat flow from the floor slab to the ground surface outside the building.

Vertical exterior insulation is the only method of reducing heat loss at the edge of an integral grade beam and slab foundation. A major advantage is that the interior joint between the slab and foundation wall need not be insulated, thus simplifying construction. However, there are several drawbacks to this method. The rigid insulation must be covered above grade with a protective board, coating, or flashing material; brick facings that contact the covering can create a thermal short that bypasses both the foundation and above-grade insulation. A further limitation is that the depth of the exterior insulation is controlled by the footing depth. Vertical exterior insulation may provide concealed pathways for termite infestation in some climate areas.

Thermal insulation also can be placed vertically on the interior of the foundation wall or horizontally under the slab. In both cases, heat loss is reduced and the difficulty of placing and protecting exterior insulation is avoided. Interior vertical insulation is limited to the depth of the footing, but underslab insulation is not. Usually, the outer 2 to 4 ft of the slab perimeter is insulated. The joint between the slab and the foundation wall must contain insulation whenever insulation is placed inside the foundation wall or under the slab. Otherwise, a significant amount of heat transfers through the thermal bridge at the slab edge. Insulation is generally limited to a thickness of 1 in. at this point.

Another option for insulating a slab-on-grade foundation is to place insulation above the floor slab. A wood floor deck can be placed on sleepers, leaving cavities that can be filled with rigid board or batt insulation, or directly on rigid insulation above the slab, which avoids some construction detail problems inherent in more conventional approaches, but may cause a greater frost depth near the slab edge.

Moisture Control. High moisture levels in a foundation can rapidly degrade the thermal performance of most types of foundation insulation. Properly constructed foundations with good drainage and damp-proofing should keep moisture loads from foundations below 0.8 gal/day; however, Christian (1994) reported foundations that contribute 0.5 to 20 gal/day. Elevated moisture levels increase the potential for mold and mildew growth, odors, pathogens, and serious health effects to occupants. Because the surface temperature is colder during winter than the crawlspace air, the relative humidity of the crawlspace air can be much lower than on the surface. Frequently, methods used to solve the problem in existing buildings are energy-intensive (e.g., year-round operation of dehumidifiers). In warm, humid climates, the dew-point temperature of crawlspace air is often high. This results in surface relative humidity above the 80% threshold identified by Hens (1999) at which fungal defacement is likely to develop.

Basement. Rain is carried away by gutters, downspouts, grading away from the building, and a cap of low-permeability backfill

material. Subgrade drainage by a drain screen (gravel and footer drain connected to daylight, sump, or storm sewer) prevents water from reaching the foundation wall.

Damp-proof or waterproof materials on the exterior of the foundation wall and over the top of the footing control moisture transport. Capillary moisture movement into the slab is controlled by a 4 in. thick granular layer under the slab.

All air leakage openings (e.g., floor slab/wall intersection, rim joist area) are sealed with durable caulking materials, closed with gasket systems, taped, or covered with membranes. Material selections should be based on the climate in which the structure is located.

Damp-proofing on the wall and polyethylene under the slab control vapor diffusion. During heating periods, vapor diffusion from the basement interior may transport moisture into the rim joist framing, where it accumulates. Rigid insulation installed on the exterior of the rim joist limits periods of potential condensation.

Slab-on-Grade. The ground should be graded to direct water away from the building; many codes recommend a 5% grade extending 10 ft from the foundation. A granular layer under the concrete slab provides a capillary break between the soil and slab. This layer can also be integrated into a subslab ventilation system to reduce radon levels. Extending the vapor retarder over the top of the foundation wall and placing appropriate flashing for any brick facing provide a capillary break to protect the above-grade wall from ground moisture penetration.

A vapor retarder placed under the slab restricts both radon gas entry and water vapor diffusion through the slab. If ducts are placed in the slab, moisture may enter the conditioned space because groundwater and soil gas will likely seep into the ducts.

Air Movement/Radon Control. Construction techniques to minimize radon infiltration through the foundation are appropriate where radon is present. General approaches include sealing joints, cracks, and penetrations in the slab and walls, and evacuating soil gas under the foundation.

A tight foundation and a discharge system reduce the chimney or stack effect that draws air from the foundation or basement into the house. If radon levels are excessive, a passive discharge system can be connected. If further relief is needed, an inline duct fan can be installed in the discharge system (Figure 1).

Subslab depressurization effectively reduces radon concentrations to acceptable levels, even in houses with high concentrations (Dudney et al. 1988). This technique lowers pressure around the foundation envelope, causing the soil gas to be routed into a collection system and discharged to the outdoors.

A continuously operating fan should not be relied on as a discharge method. Ideally, a passive depressurization system should be installed, radon levels tested, and, if necessary, the system activated by adding a fan. The fan should be located in an accessible section of the stack so that any gas leaking from the positive-pressure side of the fan does not enter the living space.

Active subslab depressurization also raises some long-term concerns. If radon barrier techniques are not fully used, indoor air could be drawn into the basement and subsequently discharged, increasing energy costs. Durability is another concern, particularly with motor-driven components. Also, the system is susceptible to owner interference.

Walls

Low-Density Construction. The most common type of light-weight wall construction is the **wood frame** wall. Most houses in North America have exterior walls framed with wood studs, although steel studs offer several advantages; for example, they are more dimensionally stable and are truer than wood studs. Additionally, **steel studs** can be fabricated from recycled material and are themselves recyclable. However, these studs can create a significant thermal bridge across the cavity insulation, reducing its thermal

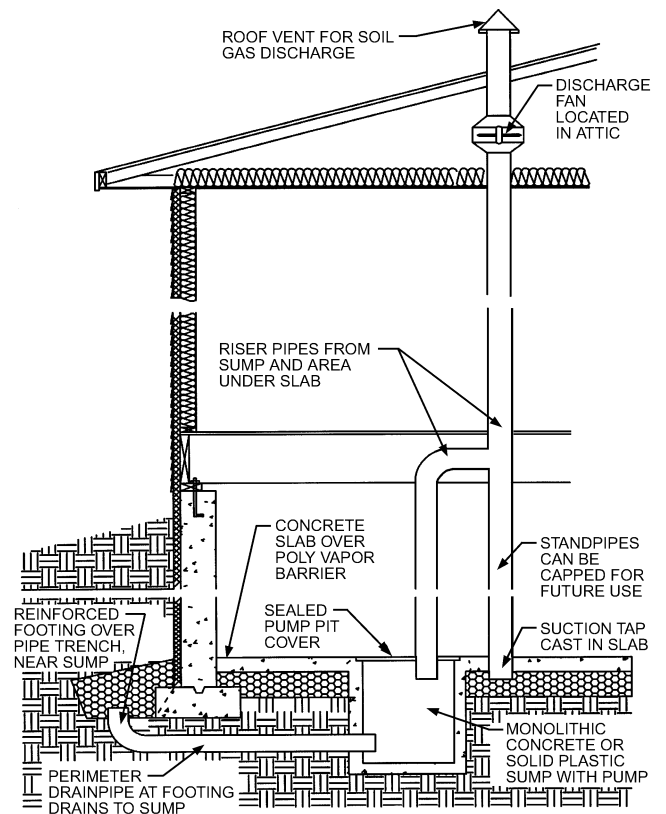

Fig. 1 Soil Gas Collection and Discharge Techniques

resistance by up to 50%. Different heat transfer between the framing member and cavities may lead to thermal anomalies with visual consequences (surface discoloration from drift accumulation, or ghosting). Insulated sheathing helps mitigate the effect of these differences. Additionally, light-gage steel construction has a lower moisture-storage capacity than wood, which can make steel-framed assemblies more sensitive to moisture infiltration.

The interior side of the framing is typically sheathed with gypsum wallboard. In cold-climate wood construction, to enhance the wall's energy efficiency, foam insulation sheathing can be applied between the gypsum board and the framing. An advantage of this practice is that the low-permeance sheathing can take the place of a vapor retarder. The disadvantage is that it complicates application of the gypsum board. Use of interior vapor retarders in warm, humid climates may be undesirable, and should be reviewed by the designer.

Cavities between framing members are filled with thermal insulation, including batt, loose fill, stabilized loose fill, site-injected foam, and rigid foam boards. With all products, the level of performance is related to the quality of the installation. Batts should be installed to completely fill the cavities along the back corners and the depth of the cavity. Gaps created by framing members or voids in an insulation caused by material settling or by improper installation can significantly reduce thermal performance. Dry loose fill should be installed at the manufacturer's recommended minimum density to avoid settling or the formation of voids. Wet loose fills should be installed with the proper amount of moisture, as recommended by the manufacturer. Stabilized loose fill insulations are applied with adhesive and water to prevent settling and movement within the cavity. As these products dry, some shrinkage has been observed; this can affect the wall's thermal performance. Before the cavity is sealed, enough time must be allowed to remove any excess water added by the application process. Site-injected foams are introduced with a hose and allowed to expand in the cavity and

interstitial spaces. Rigid foam board, sometimes used as an insulation material, is cut to size and placed tightly between studs.

Commonly used exterior sheathing materials include gypsum sheathing, plywood, oriented strand board (OSB), and foam insulating sheathing. For low-rise buildings, usually less than three stories, airflow retarders are installed on the outside of the exterior sheathing and covered with an exterior finish such as vinyl or aluminum siding, stucco, or brick.

Airflow can be retarded by constructing a continuous, air-impermeable plane at the sheathing surface (e.g., tongue-and-groove gypsum board with taped joints). The sheathing/window, sheathing/roof, and sheathing/floor junctions are also sealed.

When an insulating sheathing is used, vertical or horizontal spacer strips can be installed between the siding and sheathing to (1) provide a rain screen, (2) increase thermal resistance by maintaining an air space between the reflective foil on the sheathing and the siding, and (3) provide a nail base for the siding.

If the exterior finish is an **exterior insulation finishing system (EIFS)**, a layer of insulation is attached to the exterior wall, and a synthetic glass-mesh-reinforced coating is attached to the insulation. An EIFS is usually applied by hand to the wall on site; it also can be prefabricated as panels in a factory.

Panelized walls are composed of an insulation layer faced on both sides with a sheathing material. The insulation layer ranges in thickness from 2 to 12 in. OSB is the most widely used sheathing material, but gypsum sheathing and plywood are also available. Because of evolving techniques for energy-efficient splines, panelized walls can have significantly fewer thermal bridges than wood frame construction.

Interior and exterior finishes for panelized walls are similar to those used in wood frame construction. Some panelized walls may already have suitably finished surfaces. Advantages of using panelized walls include (1) higher energy efficiency than typical wood frame wall systems, (2) little or no thermal bridging in the clear wall area, (3) tighter-than-average construction because of reduced jointing if large panels are used, and (4) integration of the insulation into the panel system, making insulation installation unnecessary. Potential problems with panelized walls are (1) facer delamination in improperly built assemblies, (2) fire safety concerns with the use of cellular plastics (an issue in *any* wall with insulating sheathing), and (3) insect control (carpenter ants have been reported to nest in hollows carved in the panels).

Masonry Construction. A common masonry wall is made with concrete masonry units (CMUs), blocks of concrete cast in various shapes and joined with mortar to form a wall. The concrete used to fabricate CMUs is produced with a variety of aggregates and typically varies in density from 85 to 135 lb/ft³ (Andrews 1989). A CMU wall provides a finished, durable interior and exterior surface. Holes can be drilled through the wall for utility penetrations. Many CMUs are available with patterns cast into the exterior face, thus providing diverse exterior finishes. Interior or exterior sheathing, and/or an airflow retarder, can be applied to improve energy efficiency or to obtain a desired finish. However, water can leak through CMU walls into the building interior. Furthermore, moisture in the CMU can cause damage through freeze/thaw action. Exterior treatments can be used to reduce moisture pickup rates of CMUs.

If an EIFS is attached to the wall exterior, the insulation separates the wall from fluctuating outdoor temperatures. This method of insulation can be used to advantage in energy-efficient buildings in which the thermal energy stored in the wall mass is used to moderate indoor temperature swings. External placement also allows the wall cavity to be used for utilities that might be susceptible to freezing or heat loss. It is important that the edges of an EIFS be tightly abutted so that thermal bridges are minimized.

Steady-State Thermal Performance. James and Goss (1993) summarize heat transmission coefficient measurements and calculations for various wall, roof, ceiling, and floor systems. These data

are only for clear wall areas that do not include subsystems or the effects of joints created at intersections with another portion of the building envelope.

To test the validity of applying clear-wall data to the wall system, a series of three-dimensional heat conduction simulations was performed on a single-family, detached one-story house (Kosny and Desjarlais 1994). These simulations showed that, for a conventional 2 by 4 in. wood-frame wall system with studs installed on 16 in. centers, the average area-weighted whole-wall R-value was 91% of the clear-wall R-value. For a similar wall using 3.5 in. steel studs, the whole-wall R-value was 83% of the clear-wall R-value. A similar two-dimensional analysis of an attached two-story steel stud house by Tuluca et al. (1997) showed the R-value for the wall system to be 40 to 50% of the clear-wall R-value. Thermal bridging can occur through framing, metal ties through exterior sheathing, and exposed slab edges.

The thermal bridges created by webs of concrete masonry units dictate the maximum thermal efficiency that a CMU can attain. To reduce thermal bridging, blocks containing only two webs instead of the usual three have been used, and web cross section has been reduced by up to 40%. However, even such changes in block design have not significantly improved wall R-value. Applying lightweight concretes with significantly lower thermal conductivity effectively improves thermal performance of these masonry units (Kosny and Christian 1995a). The same strategy can be used for CMUs containing core-insulating inserts or insulation fill; insulating inserts in high-density concrete blocks are ineffective.

Dynamic Thermal Performance. The steady-state R-value traditionally used to measure energy performance of a building envelope does not accurately reflect the dynamic thermal behavior of all complex building envelope systems. Further information can be obtained in Chapters 24 and 32 of the 2005 *ASHRAE Handbook—Fundamentals*.

Moisture. Historically, the primary moisture control strategy for walls is to restrict moisture entry. Another approach to envelope design is to provide walls that balance entry with removal and that control accumulation and pressure differential.

Recognizing that lightweight wall systems can get wet or occasionally start out wet, the designer can promote weather protection and drying. A rain screen (Figure 2) can be placed immediately behind the exterior cladding to control rain penetration by providing a pressure-equalized air space, or a house wrap, which is vapor-permeable and water-impermeable, can be installed over the exterior sheathing to protect the wall from weather yet allow it to dry if necessary.

For heating-dominated climates, a vapor retarder at the interior surface is advisable. Moisture originates from the interior of the building and migrates into the wall until it reaches the interior vapor retarder, which is kept warm because it is inside the thermal envelope. In cooling-dominated climates, exterior sheathing of impermeable rigid insulation can act as a vapor diffusion retarder. Moisture outside the building moves into the wall until it reaches the exterior vapor retarder, which is kept warm because it is outside of the thermal envelope. As a general rule, to keep moisture condensation accumulation to a minimum, this first condensing surface must be kept above the dew point.

Air Movement. Uncontrolled air movement across walls increases space conditioning costs and may cause moisture to condense. **Air infiltration** is air movement from outside into the conditioned space. **Air exfiltration** is air movement from the conditioned space to the outside. **Air intrusion** is penetration of air into the building envelope without entirely crossing it. For example, outside air can penetrate a wall at sheathing joints, move around or through the insulation, and return to the outside. Similarly, inside air can penetrate a wall at electric outlets, move around or through the insulation, and return to the conditioned space. **Air leakage** designates any type or combination of air movement in and across the

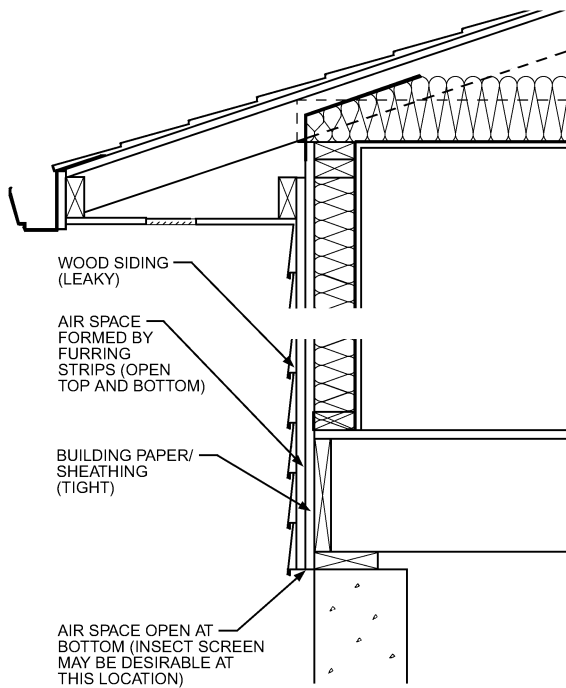

Fig. 2 Example of Rain Screen

envelope (see Chapter 27 of the 2005 *ASHRAE Handbook—Fundamentals*).

In general, an **air barrier** should be installed in walls. The air barrier reduces both infiltration and exfiltration. It also prevents intrusion by exterior or interior air, depending on the location of the air seal plane. Refer to Chapters 24 and 25 of the 2005 *ASHRAE Handbook—Fundamentals*.

In heating-dominated climates, the air barrier can be positioned on either the exterior or interior of the wall (e.g., framing). If placed to the exterior of stud construction that does *not* have insulating sheathing, the air barrier protects insulation located between framing members from cold air intrusion.

The air barrier can also be placed to the exterior of stud construction that has insulating sheathing, such as steel stud walls with fibrous insulation, gypsum board sheathing, rigid insulation sheathing, and brick finish. If the air barrier is on the winter-cold surface of the sheathing, it can be moisture-impermeable if the R-value of the rigid insulation is sufficient to maintain the air barrier above dew point during winter conditions. Impermeable air barriers are usually bituminous, rubber-based, or plastic membranes. However, the air barrier can also be composed of a gypsum board layer with the junctions taped and sealed. Masonry construction usually includes air-impermeable air barriers.

If the air barrier is placed to the interior of a wall in a heating-dominated climate, it protects the wall from intrusion by moist interior air. In theory, this type of barrier is more advantageous than an exterior barrier for structures where moisture condensation is likely, such as steel studs without insulating sheathing that surround a space with high humidity in winter. In practice, it is difficult to achieve a continuous air seal at the interior surface of a wall, especially in multistory buildings, because of the wall/floor and wall/ceiling junctions. A continuous air seal plane could be achieved by gypsum board with or without a polyethylene vapor retarder if particular attention is paid to details and with special construction supervision.

In hot, humid climates, the air barrier for air-conditioned buildings should be vapor-permeable if it is placed nearest the interior of the wall because the outside moist air can condense on cold interior surfaces. The exterior air barrier can be either moisture-permeable or

moisture-impermeable. If the barrier is moisture-impermeable, the insulated layer near the conditioned space must have a sufficient R-value to keep the membrane above the dew point. This caveat applies to each component of the insulated layer separately.

In climates requiring significant heating and cooling, heating-dominated construction is usually indicated, but moisture accumulation calculations need to be performed if layers with low vapor permeance are used. In climates with some heating, significant cooling, and high humidity, it is usually prudent to avoid vapor-impermeable air barriers and layers with low vapor permeance on the interior of the wall assembly.

In general, except for prefabricated wall panels, two layers with low vapor permeance (e.g., an exterior vapor-impermeable airflow retarder and an interior vapor retarder) should be avoided because moisture can be trapped in the wall during construction or operation.

Roof and Ceiling Assemblies

Thermal Performance. In pitched roof assemblies, attic space is typically insulated with mineral fiber batts or blankets and/or mineral fiber or cellulose loose fill insulation. The total thermal resistance of the ceiling plus insulation, attic space, and roof is the sum of the conduction resistance of the ceiling plus insulation and the effective attic resistance. The roof resistance is generally negligible.

Thermal performance of the insulation varies with mean temperature. In winter, thermal resistance of the insulation increases; in summer, it decreases. In installing loose fill insulation, care must be taken to avoid overblowing the material to densities below the intended design density for a given R-value. At densities below design, the material may not deliver the desired R-value. To prevent overblowing, the correct amount of material for a given coverage area and R-value should always be installed. Manufacturers of loose fill insulation are required to provide maximum net coverage information on all product packaging. Some high-density loose fill products may gradually settle to a lower thickness after being installed. The reduced thickness decreases the thermal resistance despite the increased density. For materials subject to settling, initial installed and settled thickness information should be available on package labels or from manufacturers so that the desired settled R-values can be achieved.

Some low-density loose fill materials are porous enough that very low temperatures at the top of the insulation may lead to free convection in the insulation. For example, Wilkes et al. (1991) observed that effective thermal resistance decreased by nearly 50% from nominal values when temperature differences greater than 70°F were imposed. Free convection can be suppressed by placing a layer of batt insulation over the low-density loose fill insulation. Alternatively, batts or blankets can be installed first and the low-density loose fill blown in on top of the batts or blankets. Mineral fiber batts or blankets should be installed at the proper width so that there are no air gaps between the batts.

In a roof assembly over a ventilated attic space in a cooling-dominated climate, insulation may be supplemented by a **radiant barrier** of high-reflectance material to reduce radiant heat transfer between the hot roof and the relatively cool ceiling. The radiant barrier can be attached to roof rafters or fastened directly to the underside of the roof sheathing with the reflective surface facing down. Care should be taken to not disturb and damage existing insulation when retrofitting an attic with a radiant barrier. Also, dust decreases the effective reflectance of the radiant barrier over time; however, if the operative surface faces down, the reduction in thermal performance should be minimal.

During the cooling season, a radiant barrier reduces temperatures affecting the air, insulated surfaces, and HVAC ducts and equipment located in the attic space. A ventilated radiant barrier combined with an equally divided, continuous soffit and ridge vents provides optimal performance. The most cost-effective use of radiant barriers is

in cooling-dominated climates. Use of radiant barriers in other climates may result in a net annual increase in energy use because the beneficial attic heat gain in the noncooling seasons is lost. The U.S. Department of Energy (DOE 1991) compared the present-value savings of radiant barriers with those of conventional fibrous insulation for several climates and circumstances.

During the cooling season, a radiant barrier under the roof sheathing increases the efficiency of a duct system located in an attic (Hageman and Modera 1996). DOE (1991) does not consider this case.

With or without a radiant barrier, **powered ventilation** increases the effective attic resistance by reducing the temperature difference between the inside conditioned space and the attic space (see Table 5 in Chapter 25 of the 2001 *ASHRAE Handbook—Fundamentals*). However, this method is rarely cost-effective because of the energy cost of the fan. Additionally, powered ventilation can draw air from the conditioned space into the attic and, consequently, from the exterior to the interior space, subjecting it to increased sensible and latent loads associated with more air infiltration.

In low- or no-slope roofs, the insulation is a layered assembly comprising the deck, insulation, and membrane. Although there are relatively small gaps between the components, the high thermal resistance of the insulation keeps total heat flux low. However, heat flow through metal penetrations can be more than 1000 times greater than that through adjacent insulation. Therefore, the area of these thermal bridges should be kept small in proportion to the roof area. Minimizing this area may require interrupting potential bridges; for example, staggering fasteners that secure the insulation to the deck and those that attach the membrane to the insulation.

Moisture. In addition to moisture normally present in construction materials, moisture can be trapped in the roof and ceiling assembly from rain during construction, leaks that were not fixed before water entered the assembly, or reroofing over partially torn-off roofs. Additional moisture can enter a structure having no insulation vapor retarder. If porous insulation is used, water vapor can diffuse throughout the assembly. The amount of vapor may be insufficient to significantly affect the thermal conductivity of the insulation, but it may add a significant latent heat load. Diurnal temperature variations in the roof can cause water to evaporate, move as vapor through a porous system, and condense (Hedlin 1988). When conditions are right for this effect, heat flow from this factor alone can easily exceed normal conduction flows.

Air Movement. With pitched roofs, the attic normally is ventilated by airflow from the edges of the assembly, over the insulation, and out through continuous ridge vents or occasional vents in the roof or gable ends of the attic. Ventilation may be by natural or forced convection, but natural convection by a combination of continuous ridge vents and continuous soffit vents seems most effective. A type of low- or no-slope roof called a **ventilated cold-deck system** has vents at the eaves and at intervals over the roof to allow circulation of dry outside air over the insulation. The effectiveness of such vents is uncertain in regions with a cold or a temperate but humid climate (IEA 1994). An alternative is a **nonventilated cold-deck system** with a vapor retarder on the ceiling consisting of staggered strips of polyethylene on the bottom and top and exposed fabric between them. Vapor inside the building effectively “sees” a continuous layer of polyethylene because of the staggering. Condensed water wicks through the exposed fabric on the top to the exposed fabric on the bottom and evaporates to the inside (Pedersen et al. 1992).

FENESTRATION

Conduction/Convection and Radiation Effects

Heat transfer through a window resulting from a temperature differential between the inside and outside (i.e., conduction, convection, and radiation) is a complex and interactive phenomenon. Although the glass itself is a poor insulator, it is used effectively in

a window to create thin insulating air films on either side of single glazing or dead air/gas spaces between glazing layers. Glass can also decrease direct transmission of radiant energy from the room or ambient sources. Chapter 31 of the 2005 *ASHRAE Handbook—Fundamentals* discusses fenestration in much greater detail.

Examination of the modes of heat transfer in a double-glazed window indicates that approximately 70% of the heat flow is through radiation from one glazing layer to another (Arasteh et al. 1985; Selkowitz 1979). Although the glass blocks direct transmission of radiant energy, energy is still absorbed and reemitted. Low-emittance coatings that are transparent to the eye significantly reduce the amount of heat transfer through a glazing cavity.

With the radiation mode of heat transfer minimized, conductive and convective modes dominate. To reduce these modes, gases with low conductivity (e.g., argon or krypton) are used in low-emittance-coated, multiple-glazed windows. Triple or quadruple glazing layers can additionally reduce heat transfer. See Chapter 31 of the 2005 *ASHRAE Handbook—Fundamentals* for design information.

Air Infiltration Effects

Air infiltration is uncontrolled movement of air from the outside to the inside of a building. It is a function of the pressure difference between the inside and outside environments (which is a function of wind speed, inside/outside temperature differences, and mechanical air balance) as well as window sealing characteristics (Klems 1983; Weidt and Weidt 1980). The infiltration rate of a fenestration product is a function of its method of operating (if any), weatherstripping material used, and construction quality. See Chapter 27 of the 2005 *ASHRAE Handbook—Fundamentals* for design information.

Solar Gain

Solar gain through windows can play a significant role in the energy balance of a building. Glazings transmit, reflect, or absorb a given wavelength of solar radiation, depending on the glazing characteristics. Transmitted solar radiation contributes heat to a space. Absorbed solar radiation is reemitted and/or conducted either to the inside or to the outside (depending on the window's glazing system configuration). Reflected solar radiation does not contribute heat to a space (Arasteh et al. 1989). Clear glass, the most common glazing material, transmits fairly evenly across the solar spectrum. Tinted or heat-absorbing glass absorbs solar radiation and gives the glass a specific color. Some tints exhibit a significant degree of spectral sensitivity (i.e., they do not transmit, absorb, and reflect evenly across the solar spectrum). These types of glazings offer great flexibility and can be tailor-made for specific climates or uses (e.g., provide ample daylighting without overheating an interior space).

Interactions Between Thermal Loss and Solar Gain

In heating-dominated applications, solar gain can provide a significant amount of heat. In many cases, heat supplied by the window can offset that lost through the window. The amount depends on the site characteristics (e.g., how much solar gain is available, how cold the climate is) and window characteristics (e.g., its U-factor and how much incident solar radiation is transmitted).

Typical **passive** solar applications try to maximize the amount of solar heat gain by installing significant amounts of south-facing glass, which receives the most solar radiation during the winter (in the northern hemisphere). However, high-performance windows facing north in a heating-dominated climate can provide more solar gain to a space than heat loss (Arasteh et al. 1989; Dubrois and Wilson 1992; Sullivan et al. 1992).

Wall/Window Interface

Air infiltration at the wall/window interface can cause serious damage to surrounding building materials and even to remote

materials, depending on the leakage path. In cold climates, warm, humid inside air can condense in the wall cavity. The condensate can damage the interior finish, seals of glazing units, insulation, exterior cladding, and possibly structural elements. Cold-air infiltration can affect the health and comfort of occupants by creating a dry indoor environment, cold drafts, and condensation and mildew on inside window surfaces. Air infiltration can also allow rain to enter the wall. Many materials are installed by many trades at the wall/window interface, making it difficult to inspect and prone to leak. In warm, humid climates, leakage at the wall/window interface can result in interior fungal growth, distortion of interior window trim, and deterioration of interior gypsum wallboard.

Control of Air Leakage

Control of air leakage must be continuous across the entire building envelope to be effective. To ensure continuity at the window, components that control airflow must be unified.

In a masonry wall, a self-adhesive asphalt membrane fastened to the masonry makes the wall airtight. A bead of sealant preserves airtightness between the glazing unit and the inner part of the metal window frame. Thus, the asphalt membrane and inner part of the metal frame are the two materials joined to withstand large air pressure loads. The membrane is extended and mechanically clamped to the inner part of the frame.

Control of Moisture Diffusion

Vapor diffusion across a small gap at the window/wall junction causes little building damage under average environmental conditions. Moreover, typical interior finishes covering the joint, made of metal or plastic or painted drywall, offer some resistance to moisture diffusion.

Control of Heat Flow

Continuity of the plane of thermal insulation is important primarily to reduce the potential for condensation on interior surfaces of the window and the surrounding interior finish. Insulation can be inserted in the joint between the wall and the window frame to compensate for the expected differential movement between the frame and the wall rough opening.

Control of Surface Condensation

To reduce the potential for condensation on the interior surface of the glazing and the frame of windows, as well as on the surrounding interior finish of the wall, the inside surface temperature can be controlled in the following ways:

- Select windows with appropriate condensation resistance for new construction.
- Seal the wall/window interface and between the sash and frame of operable windows to keep air leakage to a minimum.
- Make the area of window frame exposed to the interior larger than the area exposed to the outside. Metal frame extensions on the inside have a higher resistance to condensation but contribute to heat loss.
- Reduce excessive interior humidity levels.

Control of Rain Entry

Applying the rain screen principle at the wall/window interface requires the same features as applying it to the wall: (1) an airflow retarder, (2) a rain deflector on the outside of the interface, (3) much more venting on the outside face of the interface than on the inside, and (4) a drainage path toward the outside.

The line of airtightness is on the inside of the assembly, so the assembly is protected from water, ultraviolet rays, and extremes of temperature. The rain deflector on the outside acts as a rain deterrent only, not as a watertight/airtight seal. A non-airtight rain deflector does not threaten the weathertightness of the system because

pressure differences across the rain deflector are small. The key is to maintain airtightness on the inside of the joint. With little pressure difference across the rain deflector and with good detailing for outward drainage of the cavity, rain entry in the wall should be minimal. The interface of an exterior wall air barrier and an interior fenestration air barrier must be carefully considered during design and may require site mock-ups to adequately determine the best solution.

Face Seal Approach

The face seal approach calls for perfect sealing of the outer face of the wall/window junction. This sealed surface protects against rain and air infiltration. The seal must remain perfect over time; its maintenance schedule is quite demanding. It is also complicated because water leaks can follow indirect paths for entry indoors, and in a large building, it may be difficult to trace these paths back to the entry points.

WALL/ROOF INTERFACE

Control of Air Leakage

In low-sloof roof configurations, the roofing membrane forms a plane of continuous airtightness and therefore can and should be connected to the wall airflow retarder. However, the wall airflow retarder could also be connected to other airtight roof components, such as the roof deck or the roof vapor retarder.

Many building systems provide for differential movement between the wall and roof assemblies; in those systems, a flexible airflow retarder connection is required at the location of the movement control joint. In all systems, the airflow retarder must withstand wind-induced pressures and fully adhere to a rigid, structurally adequate substrate.

[Figure 3](#) shows an assembly that uses the concrete roof deck to achieve a continuous wall/roof airflow retarder. The retarder of the wall assembly is connected to the concrete slab using a sheet airflow retarder material. The connection between the wall and slab edge retarder sheets is designed to accommodate differential movement of the wall and roof.

[Figure 4](#) shows a protected membrane roof assembly in which the roof membrane is an airflow retarder that extends over the edge of the roof perimeter to connect to the wall airflow retarder. A sheet metal backing is used around the roof deck perimeter for attachment and to provide for differential movement at the interface.

In some types of curtain walls, such as the wall in [Figure 5](#), the air seal must be made continuous over the parapet wall. This

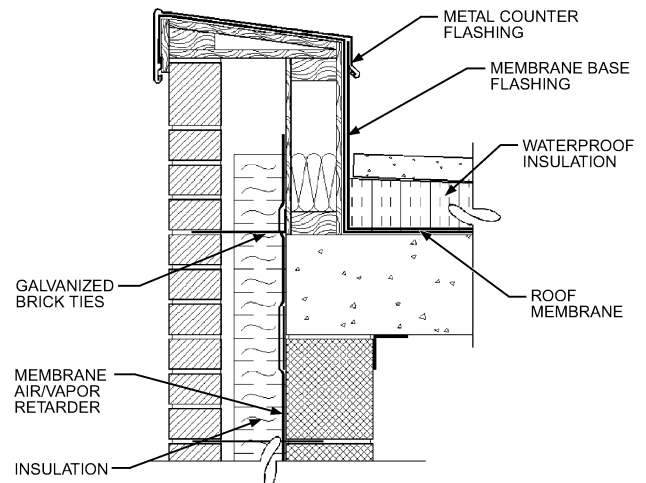

Fig. 3 Detail of Concrete Roof Deck with Continuous Wall/Room Airflow Retarder

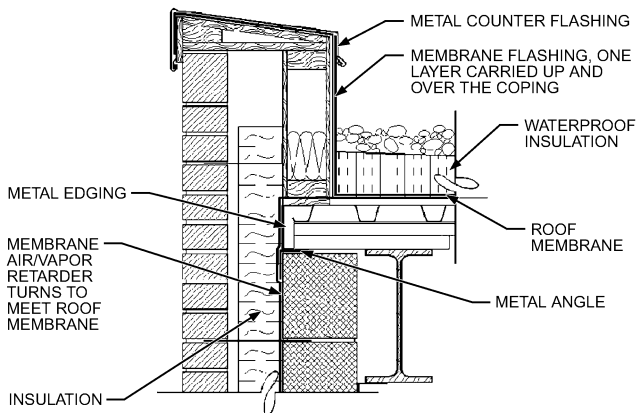

Fig. 4 Protected Membrane Roof Assembly

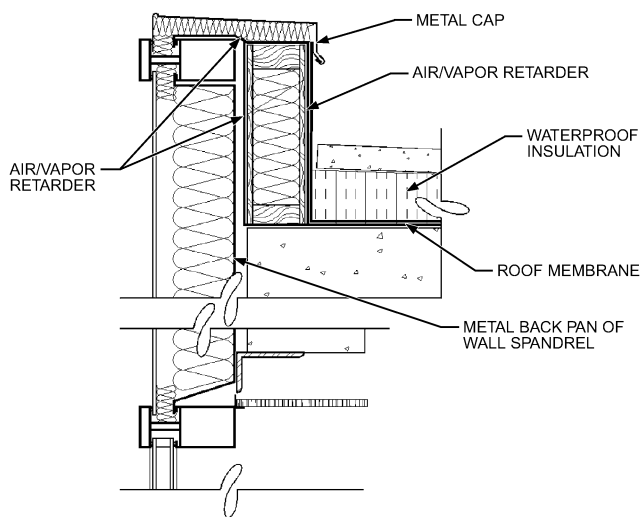

Fig. 5 Continuous Air Seal in Curtain Wall

allows connection of the wall air seal (the metal back pan of the spandrel panel) to the membrane flashing of the roof assembly or to the air/vapor retarder on the parapet, as in asphalt and roofing felt systems.

Control of Moisture Diffusion

The vapor retarder can also act as an airflow retarder, as shown in Figure 5, in which the metal back pan of the wall spandrel connects to the air/vapor retarder membrane on the parapet upstand wall. Because the parapet is encased in vapor retarder sheets, it must be kept dry before it is enclosed because any moisture left in the parapet cannot disperse. A vapor retarder with wicking properties could provide a better solution.

Control of Condensation

Condensation at the connection between the roof and wall can occur in interstitial spaces because of a lack of continuity in either system. Condensation also occurs if the vapor retarder temperature falls below the dew point of the air on the high-vapor-pressure side. Thus, thermal insulation applied to the exterior (winter-cold surface) of the vapor retarder must be sufficient to ensure that the temperature at the retarder plane remains higher than the dew point of the air. The temperature of the interior space between the exterior wall system and the parapet upstand wall often falls below the temperature of the interior inhabited space because of poor air circulation above the ceiling. Therefore, insulation applied over the parapet

cap and upstand wall may need to have greater thermal resistance than insulation for the wall or roof.

In exterior insulated wall systems (e.g., an EIFS or a curtain wall), thermal bridging must be minimized to control condensation between the parapet cap and the parapet upstand wall.

THERMAL BRIDGES IN BUILDINGS

A **thermal bridge** is an envelope area with a significantly higher rate of heat transfer than the contiguous enclosure. An example of thermal bridging is a steel truss in an attic with glass fiber insulation placed between trusses. The thermal conductivity of steel is about 1000 times greater than that of glass fiber insulation, so strong thermal bridging results along the trusses. In most construction details, the ratio between the high- and low-conductivity areas is smaller. An uninsulated CMU wall with brick facing could have a U-factor of 0.33 Btu/h·ft²·°F if the CMU is made with sand and gravel aggregate. A concrete column located within that wall has a U-factor about 50% higher. This higher conductivity may justify classifying the column as a thermal bridge, but in typical construction this classification is relevant only if the concrete column proves to be detrimental for reasons other than energy use (e.g., moisture condensation).

Thermal bridges can be created by conduction, as in the previous examples, by radiation, by convection, or by a combination of those three modes of heat transfer (Silvers et al. 1985). Strong radiation effects occur, for instance, in an uninsulated brick wall retrofitted with metal cladding. The cladding is placed at some distance from the exterior of the brick wythe. The warmer brick wall radiates to the cold metal sheet. The different temperatures of the two surfaces also engender air convection.

Detrimental Effects of Thermal Bridges

Thermal bridges increase energy use, promote moisture condensation in and on the envelope, and create nonuniform temperatures in conditioned spaces. Comparison between the uninsulated slab edge detail of Figure 6A and the version with slab edge insulation with an R-value of 10 ft²·°F·h/Btu in Figure 6B illustrates the importance of designing to reduce thermal bridging. [Refer to Steven Winter Associates (1988) for numerical examples summarized in this section.] This example, and the others in this section, use the term **total R-value**, where $R_t = 1/U$; R_t includes the effect of exterior and interior air films.

- **Increased energy use.** The portion of the wall that extends from the top of the slab edge to the shelf angle (Figure 6A) has $R_t = 2.3$ ft²·°F·h/Btu when the wall insulation is furred in. Moving the insulation into the wall cavity (Figure 6B) increases R_t by about 2.2 times, to 5.3 ft²·°F·h/Btu.
- **Damage to structural components.** On cold days, the uninsulated wall area collects moisture on the interior surface of the steel beam and on the slab underside. At 20°F outside air temperature, 70°F indoor air temperature, and 50% indoor relative humidity, moisture condenses on about 0.66 ft² of beam and slab for every linear foot of wall. This condensation can rust the metal beam and, if it penetrates the concrete block, can rust the brick ties. The insulated detail (Figure 6B) generates moisture condensation only on the bottom flange of the beam.
- **Damage to interior finishes.** Moisture can drip from the slab underside and from the steel beam, staining ceiling tiles and resulting in higher maintenance costs and loss of rental value. These effects are specific to the heating season and are magnified when thermal bridging is accompanied by air leakage, because air transports and deposits moisture on thermal bridges.

In cold and temperate climates, thermal bridges may slightly decrease peak cooling load and cooling energy use. In hot climates, this effect could be reversed. When the climate is hot and humid,

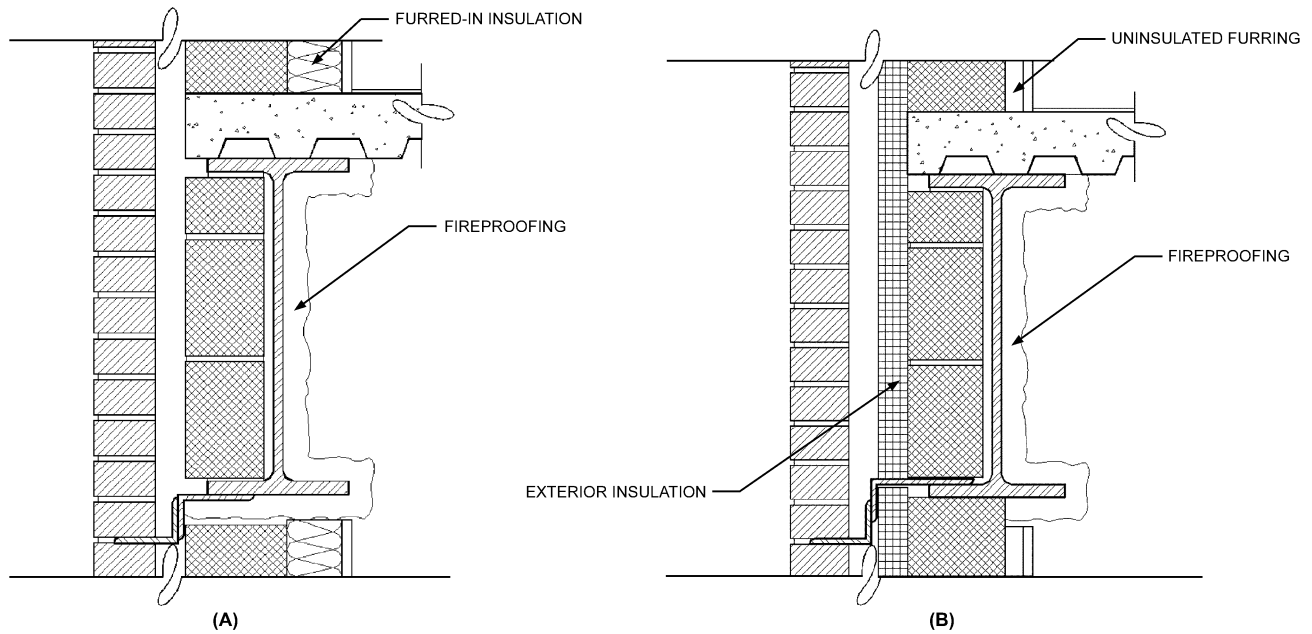

Fig. 6 Detail of (A) Uninsulated and (B) Insulated Slab Edge and Metal Shelf Angle

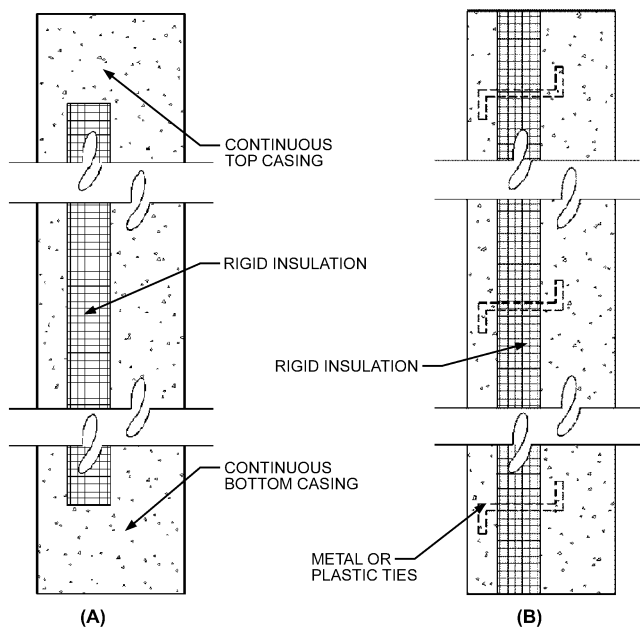

Fig. 7 Sandwich Panel with Insulation Encased in Concrete

moisture condensation can create problems if the building is air conditioned or refrigerated.

Thermal Bridge Mitigation

Primary causes for conduction thermal bridging are (1) high thermal conductivity and (2) geometries that create zones where large exterior surfaces connect to much smaller interior surfaces. Thermal bridges can sometimes be eliminated, but usually they can be mitigated to create systems with significantly lower U-factors. Examples of conduction thermal bridges and mitigating details follow:

- **Factory-produced components with high conductivity**
Sandwich panel with insulation fully encased in concrete (Figure 7A). One possible solution is to connect the exterior and interior wythes of the panel with metal or plastic tie rods (Figure 7B).

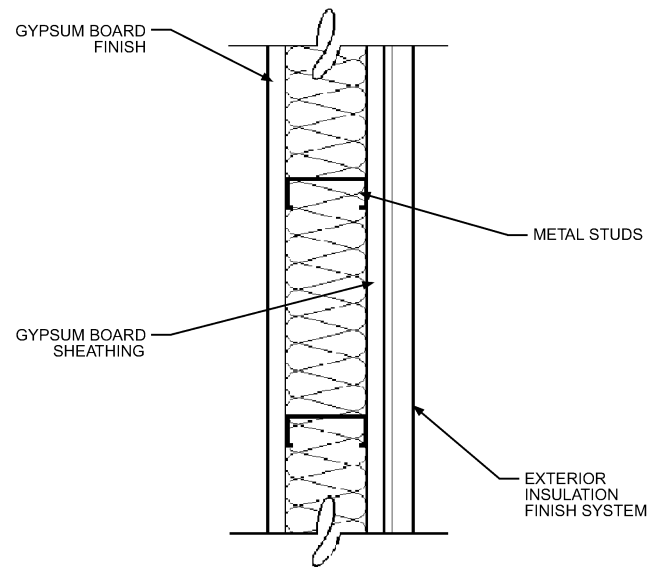

Fig. 8 Steel Studs in Insulated Wall with Ceramic Finish

This 6 ft high sandwich panel has a 3 in. extruded polystyrene core completely encased in concrete. The concrete has a conductivity over 50 times higher than that of polystyrene, resulting in $R_t = 5.4 \text{ ft}^2 \cdot \text{°F} \cdot \text{h/Btu}$. Moisture can collect on the top and bottom concrete edges of the panel. For $T_{OA} = 20 \text{ °F}$, $T_{IA} = 70 \text{ °F}$, and 50% rh, about 20% of the panel area can be covered with moisture.

When the interior and exterior concrete wythes are attached with metal or plastic tie rods, R_t of the panel increases by a factor of almost 3 to $15.1 \text{ ft}^2 \cdot \text{°F} \cdot \text{h/Btu}$ or $16 \text{ ft}^2 \cdot \text{°F} \cdot \text{h/Btu}$, respectively. No moisture condensation on interior surfaces is likely.

• **Assemblies that contain high-conductance components**

Steel studs in insulated wall. One possible solution: Provide insulating sheathing (Figure 8).

This steel stud wall is used in low-cost multifamily, commercial, and industrial construction. The exterior gypsum board is provided for fire protection. If the wall has R-11 insulation, the studs reduce the

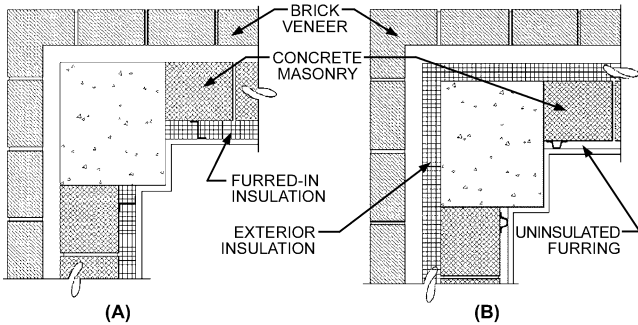

Fig. 9 Details of Insulation Around Column in Masonry Wall

wall R_t to $7.75 \text{ ft}^2 \cdot \text{F} \cdot \text{h/Btu}$. For $T_{OA} = 20^\circ\text{F}$, $T_{IA} = 70^\circ\text{F}$, and 50% rh, every linear foot of steel stud can generate 0.15 ft^2 of moisture condensation on the interior surface of the gypsum wallboard.

Extruded polystyrene sheathing 1 in. thick placed on the winter-cold surface of the gypsum board sheathing reduces thermal bridging, resulting in $R_t = 14.5 \text{ ft}^2 \cdot \text{F} \cdot \text{h/Btu}$. For $T_{OA} = 20^\circ\text{F}$, $T_{IA} = 70^\circ\text{F}$, and 50% rh, moisture is less likely to condense on interior surfaces. If polystyrene is placed on the steel studs directly, the increase in R -value is even higher because the lateral heat flow is reduced.

If all insulation is placed on the exterior surface of the steel studs, the studs are kept at a temperature close to that of the conditioned space. Moisture condensation is practically eliminated. This solution merits special consideration in spaces with high relative humidity, such as kitchens and pool buildings.

• **Junction between envelope systems achieved with high-conductance components**

Uninsulated slab edge and metal shelf angle, at junction between CMU wall and concrete floor (see Figure 6A). One possible solution is to place insulation in the wall cavity (Figure 6B).

This detail shows an uninsulated slab edge and perimeter metal beam in a CMU/brick wall. For the wall segment that extends from the top of the slab edge to the shelf angle, $R_t = 2.3 \text{ ft}^2 \cdot \text{F} \cdot \text{h/Btu}$. For $T_{OA} = 20^\circ\text{F}$, $T_{IA} = 70^\circ\text{F}$, and 50% rh, about 0.66 ft^2 of slab underside and steel beam could collect moisture along every linear foot of slab edge.

The improved detail of Figure 7B uses R-10 rigid insulation in the wall cavity. The perimeter metal beam would be insulated, and the shelf angle remains as the only significant thermal bridge. The new total R -value of the wall segment is about 2.2 times higher (i.e., $R_t = 5.3 \text{ ft}^2 \cdot \text{F} \cdot \text{h/Btu}$). Less moisture would be expected to condense along the slab edge.

Insulation is sometimes specified on the interior surface of the perimeter beam in an effort to increase the thermal resistance of this wall segment. Site conditions rarely allow the installation to be thorough, so the top and bottom flanges remain exposed, creating a strong thermal bypass and marginalizing the effectiveness of the insulation. Moreover, the insulation makes vapor condensation more likely because it decreases the temperature of the beam chord but does not stop water vapor migration.

• **Combinations of geometry with high conductivity**

Column in masonry wall with insulation located in steel stud furring (Figure 9A). One possible solution is to move the insulation in the wall cavity (Figure 9B).

Concrete columns within masonry walls are often left uninsulated. In this example, a 12 by 12 in. column is located at the junction of two exterior walls composed of 6 in. CMU and 4 in. brick. The walls are insulated with $R = 10 \text{ ft}^2 \cdot \text{F} \cdot \text{h/Btu}$ polystyrene on metal furring. The corner, which includes the column and two CMU blocks on each side, has $R_t = 6 \text{ ft}^2 \cdot \text{F} \cdot \text{h/Btu}$. This is 38% lower than the total R -value of the wall without the column ($R_t = 9.7 \text{ ft}^2 \cdot \text{F} \cdot \text{h/Btu}$). For

$T_{OA} = 20^\circ\text{F}$, $T_{IA} = 70^\circ\text{F}$, and 50% rh, every linear foot of column could collect moisture on about 0.8 ft^2 of interior surfaces.

If the insulation is placed in the wall cavity, the total R -value of the corner more than doubles, to $R_t = 12.3 \text{ ft}^2 \cdot \text{F} \cdot \text{h/Btu}$. No moisture condensation would be expected on interior surfaces of the column for the given temperature and relative humidity conditions.

Design Recommendations

These basic design principles apply to any thermal bridge.

Consider the combined effects of thermal bridging, air leakage, moisture condensation, and water intrusion. If one of these mechanisms of heat and mass transfer is involved, another one is commonly combined with it in a destructive synergy. In devising a solution for thermal bridging, ensure that moisture condensation is not increased. In climates with significant heating, this is of special concern for insulation placed on the interior (winter-warm) surface of materials with low vapor permeance, such as CMU or steel beam. In hot, humid climates, the concern relates to insulation placed on the summer-hot surface of materials with low vapor permeance.

In addition, because many thermal bridges are discontinuities in the envelope system, the chance that air will enter the envelope along these paths should be assessed. To cause damage, air does not need to infiltrate into a space from outdoors or to exfiltrate from a space to the outside; it is sufficient that air intrude in the envelope. For example, outside air can enter a stud wall cavity, short-circuiting the insulation and intensifying the thermal bridging effect, after which it exits again to the outside. In another example, indoor air can seep from the conditioned space into a furred-in CMU wall, behind the insulation and vapor retarder, increasing the chance for moisture condensation on the CMU surface. Of all forms of air intrusion, exfiltration of moist air along thermal bridge surfaces can be the most damaging. Note that the entry and exit points of air in the envelope can be distant.

It is particularly important to reduce thermal bridging, air intrusion, and moisture condensation if the following conditions are true:

- The building or spaces in it have uses that are likely to generate a relatively high amount of moisture during winter; examples are residences, hospitals, nursing homes, restaurants, kitchens, nurseries, and bathrooms.
- The building is located in an area that experiences cold winters or sustained periods of cold during moderate winters. Climates with humid winters with subfreezing periods can also create problems.
- The building is located in a warm but not dry or arid climate and has uses that require low temperatures (e.g., refrigeration), or it is located in a hot, humid area and has uses that require air conditioning.

Consider the potential for thermal bridging and air intrusion during schematic design when decisions about the envelope system are made. Some systems are inherently more difficult to insulate and airproof, and changes during design development may create budget problems.

Use reasonably accurate methods to determine the effect of thermal bridging. Accurate formulas are available for most steel stud configurations (Kosny and Christian 1995b), but they are not sufficiently accurate for many other construction types. Two- and three-dimensional models are available and provide better results.

In mitigating a thermal bridge, several techniques can be used, often in combination. Such techniques include

- Change the thermal bridge material to one with lower conductivity. Plastic ties nearly eliminate thermal bridging in concrete sandwich panels.
- Decouple the thermal bridging elements from the rest of the construction. If the steel stud furring is detached from the CMU wall, the pathway between two materials with high conductivity is bro-

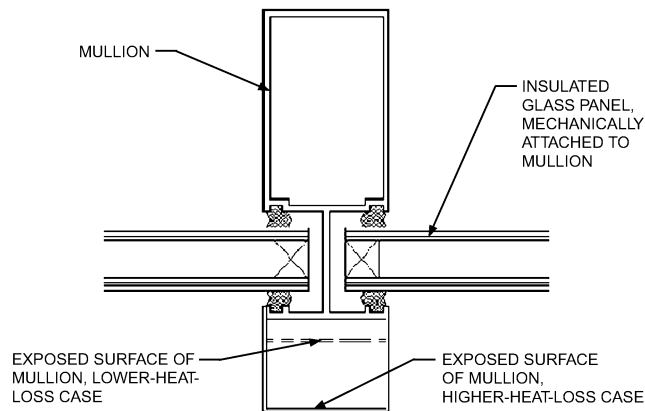

Fig. 10 Mullion with Deep Exterior Projection

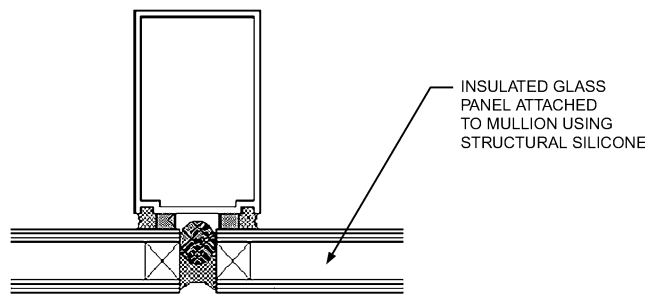

Fig. 11 Mullion Without Exterior Projection

ken. The best method to achieve the decoupling is to insert a thin, low-conductivity material, such as foam tape, at each stud. If an air space is created between the insulated steel stud layer and the CMU wythe, air convection can short-circuit the insulation.

- Change the geometry that creates thermal bridging. Figure 10 shows a mullion with a deep exterior projection. This projection acts like a fin during winter, enhancing the heat loss. One method of reducing the thermal bridging effect is to reduce the exterior projection (Figure 10, dashed line). If this is not acceptable for aesthetic reasons, implement a better thermal break system.
- Insulate the thermal bridge. For example, use insulating sheathing for steel stud walls.
- Change the insulation system. For example, a furred-in masonry wall with all insulation located in the furring could be changed to a masonry wall with rigid insulation on the exterior (winter-cold) surface of the CMU.
- Change the construction system. In a natatorium, for instance, structural silicone glazing without an exterior projection (Figure 11) might avoid moisture condensation on mullions.

THERMAL MASS

Thermal mass describes the ability of a material layer to store thermal energy and the ability of an opaque envelope component to dampen and delay transfer of heat and temperatures. That damping, if combined with moderate glazing, effective solar shading, a correct ventilation strategy, and inside partitioning with high thermal storage, helps moderate indoor temperature fluctuation under outdoor temperature swings (Brandemuehl et al. 1990). Increased thermal mass may also positively affect energy efficiency (Kosny et al. 1998; Newell and Snyder 1990; Wilcox et al. 1985). Finally, increased thermal mass may help shift demand for heating and cooling to off-peak periods.

The ability to store thermal energy in a layer primarily depends on the material’s heat absorption coefficient:

Table 1 Typical Densities, Thermal Diffusivities, and Specific Heats of Common Building Materials

Description	Density, lb/ft ³	Thermal Diffusivity, ft ² /h	Specific Heat, Btu/lb·°F
Concrete	40 to 140	0.08 to 0.30	0.22
Steel	484	0.038	0.12
Wood	22 to 44	0.005 to 0.006	0.40
Insulation	0.6 to 2.0	0.027 to 0.22	0.2 to 0.38

$$b = \sqrt{\rho ck} \tag{1}$$

where *k* is thermal conductivity, ρ is density, and *c* is specific heat capacity. See Table 1 and Chapter 25 of the 2005 ASHRAE Handbook—Fundamentals for values of these properties. The amount of thermal energy stored in a layer is governed by the **heat capacity**, the product of the layer’s mass and its specific heat capacity:

$$Q_{stored} = (\rho d)c \tag{2}$$

where *d* is the layer thickness.

Damping and time delay are defined by the way an opaque envelope component is composed. Best results are achieved when the thermal insulation faces the outside and the layers with largest heat capacity face the inside, as confirmed by an in-depth study of six wall configurations by Kosny et al. (1998). The damping capability of such a wall also increases with thermal resistance (Van Geem 1986).

Hourly-based computer simulations using transient energy simulation tools may produce a fair understanding of the complex interactions that exist between the (1) surface, type, and orientation of the glazing; (2) effectiveness of the solar shading used; (3) ventilation strategy adopted; (4) heat storage capacity of the internal partitions; (5) damping effect of all opaque envelope components; and (6) HVAC set point and control policies implemented with stable inside temperature and energy consumed for heating and cooling. However, a harmonic analysis at room level, using the transient harmonic wall properties defined in Chapter 23 of the 2005 ASHRAE Handbook—Fundamentals, helps in understanding part of these interactions.

REFERENCES

Andrews, S. 1989. *Foam core panels and building systems*. Cutter Information Corporation, Arlington, MA.

Arasteh, D.K., M.S. Reilly, and M.D. Rubin. 1989. A versatile procedure for calculating heat transfer through windows. *ASHRAE Transactions* 95(2): 755-765.

Arasteh, D.K., S. Selkowitz, and J. Hartmann. 1985. Detailed thermal performance data on conventional and highly insulating window systems. *Thermal Performance of the Exterior Envelopes of Buildings III*, pp. 830-845.

ASHRAE. 1994. Recommended practices for controlling moisture in crawl spaces. *ASHRAE Technical Data Bulletin* 10(3).

Brandemuehl, M.J., J.L. Lepore, and J.F. Kreider. 1990. Modeling and testing the interaction of conditioned air with building thermal mass. *ASHRAE Transactions* 96(2):871-875.

Carmody, J., J. Christian, and K. Labs. 1991. *Builder’s foundation handbook*. ORNL/CON-295. Oak Ridge National Laboratory, Oak Ridge, TN.

Christian, J.E. 1994. Moisture sources. *ASTM Manual* 18. American Society for Testing and Materials, West Conshohocken, PA.

DOE. 1991. *Radiant barrier fact sheet*. DOE/CE-0335P. U.S. Department of Energy.

Dubrois, F. and A.G. Wilson. 1992. A simple method for computing energy performance for different locations and orientations. *ASHRAE Transactions* 98(1):841-849.

Dudney, C.S., L.M. Hubbard, T.G. Matthews, R.H. Scolow, A.R. Hawthorne, K.J. Gadsby, D.T. Harrje, D.L. Bohac, and D.L. Wilson. 1988. *Investigation of radon entry and effectiveness of mitigation measures in seven houses in New Jersey*. ORNL-6487 (draft). Oak Ridge National Laboratory, Oak Ridge, TN.

- Hageman, R. and M.P. Modera. 1996. Energy savings and HVAC capacity implications of a low-emissivity interior surface for roof sheathing. *ACEEE Summer Study on Energy Efficiency in Buildings*. American Council for an Energy-Efficient Economy, Washington, D.C.
- Hedlin, C.P. 1988. Heat flow through a roof insulation having moisture contents between 0 and 1 percent by volume in summer. *ASHRAE Transactions* 94(2):1579-1594.
- Hens, H. 1999. Fungal defacement in buildings: A performance related approach. *International Journal of HVAC&R Research* (now *HVAC&R Research*) 5(3):265-280.
- Hutcheon, N.B. 1963. Requirements for exterior walls. *Canadian Building Digest* 48. National Research Council Canada, Ottawa.
- IEA. 1994. *A guidebook for insulated low-slope roof systems*. International Energy Agency, Annex 19: Low-slope roof systems. Prepared by Oak Ridge National Laboratory, Oak Ridge, TN.
- James, T.B. and W.P. Goss. 1993. *Heat transmission coefficients for walls, roofs, ceilings, and floors*. ASHRAE.
- Klems, J. 1983. Methods of estimating air infiltration through windows. *Energy and Buildings* 5:243-252.
- Kosny, J. and J.E. Christian. 1995a. Steady-state thermal performance of concrete masonry unit wall systems. Thermal Envelopes VI Conference, Clearwater, FL.
- Kosny, J. and J. Christian. 1995b. Reducing the uncertainties associated with using the ASHRAE-zone method for R-value calculations of metal frame walls. *ASHRAE Transactions* 101(2):779-788.
- Kosny, J. and A.O. Desjarlais. 1994. Influence of architectural details on the overall thermal performance of residential wall systems. *Journal of Thermal Insulation and Building Envelopes* 18:53-69.
- Kosny, J., E. Kossecka, A.O. Desjarlais, and J.E. Christian. 1998. Dynamic thermal performance of concrete and masonry walls. Thermal Envelopes VII Conference, Clearwater, FL.
- Newell, T.A. and M.E. Snyder. 1990. Cooling cost minimization using building mass for thermal storage. *ASHRAE Transactions* 96(2).
- Pedersen, C., T.W. Petrie, G.E. Courville, A.O. Desjarlais, R.W. Childs, and K.E. Wilkes. 1992. Moisture effects in low-slope roofs: Drying rates after water addition with various vapor retarders. ORNL/CON-308, Oak Ridge National Laboratory, Oak Ridge, TN.
- Selkowitz, S.E. 1979. Thermal performance of insulating window systems. *ASHRAE Transactions* 85(2):669-685.
- Silvers, J.P., R.P. Tye, D.L. Brownell, and S.E. Smith. 1985. *A survey of building envelope thermal anomalies and assessment of thermal break materials for anomaly correction*. ORNL/Sub/83-70376/1. Dynatec R/C Company for Oak Ridge National Laboratory, Oak Ridge, TN.
- Steven Winter Associates. 1988. Catalog of thermal bridges in commercial and multi-family residential constructions. *Report 88-SA407/1* for Oak Ridge National Laboratory, Oak Ridge, TN.
- Sullivan, R., B. Chin, D. Arasteh, and S. Selkowitz. 1992. A residential fenestration performance design tool. *ASHRAE Transactions* 98(1):832-840.
- Tuluca, A., D. Lahiri, and J. Zaidi. 1997. Calculation methods and insulation techniques for steel stud walls in low-rise multifamily housing. *ASHRAE Transactions* 103(1):550-562.
- Van Geem, M.G. 1986. Summary of calibrated hot box test results for twenty-one wall assemblies. *ASHRAE Transactions* 92(2B):584-602.
- Weidt, J.L. and J. Weidt. 1980. Field air leakage of newly installed residential windows. *LBL Report 11111*. Lawrence Berkeley Laboratory, Berkeley, CA.
- Wilcox, B., A. Gumerlock, C. Barnaby, R. Mitchell, and C. Huizenza. 1985. The effects of thermal mass exterior walls on heating and cooling loads in commercial buildings. *Thermal Performance of the Exterior Envelopes of Buildings III*, pp. 1187-1224.
- Wilkes, K.E., R.L. Wendt, A. Delmas, and P.W. Childs. 1991. Thermal performance of one loose-fill fiberglass attic insulation. *Insulation Materials: Testing and Applications 2*. ASTM STP 1116:275-91. American Society for Testing and Materials, West Conshohocken, PA.

BIBLIOGRAPHY

- Labs, K., J. Carmody, R. Sterling, L. Shen, J. Hwang, and D. Parker. 1988. *Building foundation design handbook*. ORNL/Sub/86-72143/1. Oak Ridge National Laboratory, Oak Ridge, TN.

[Related Commercial Resources](#)