



**STANDARD**

**ANSI/ASHRAE Standard 110-2016**  
(Supersedes ASHRAE Standard 110-1995)

# **Methods of Testing Performance of Laboratory Fume Hoods**

Approved by ASHRAE on March 31, 2016, and by the American National Standards Institute on April 1, 2016.

ASHRAE Standards are scheduled to be updated on a five-year cycle; the date following the Standard number is the year of ASHRAE approval. The latest edition of an ASHRAE Standard may be purchased on the ASHRAE website ([www.ashrae.org](http://www.ashrae.org)) or from ASHRAE Customer Service, 1791 Tullie Circle, NE, Atlanta, GA 30329-2305. E-mail: [orders@ashrae.org](mailto:orders@ashrae.org). Fax: 678-539-2129. Telephone: 404-636-8400 (worldwide) or toll free 1-800-527-4723 (for orders in US and Canada). For reprint permission, go to [www.ashrae.org/permissions](http://www.ashrae.org/permissions).

© 2016 ASHRAE

ISSN 1041-2336



**ASHRAE Standard Project Committee 110**  
**Cognizant TC: 9.10, Laboratory Systems**  
**SPLS Liaison: Heather L. Platt**

Wade H. Conlan\*, *Chair*  
Frederick A. Lorch\*, *Vice-Chair*  
Martin J. Burke\*  
Rob Chopwick  
Bohdan Fedyk\*  
Kevin C. Gilkison\*

Robert Hauden  
Nathan L. Ho\*  
Gerhard W. Knutson\*  
Lloyd Le  
Gary L. Miller\*  
Kurt P. Rindoks\*

David Ruhland  
Thomas C. Smith\*  
Kevin A. Sweeney\*  
Don Watson\*

\* Denotes members of voting status when the document was approved for publication

---

**ASHRAE STANDARDS COMMITTEE 2015–2016**

Douglass T. Reindl, *Chair*  
Rita M. Harrold, *Vice-Chair*  
James D. Aswegan  
Niels Bidstrup  
Donald M. Brundage  
John A. Clark  
Waller S. Clements  
John F. Dunlap  
James W. Earley, Jr.  
Keith I. Emerson

Steven J. Emmerich  
Julie M. Ferguson  
Walter T. Grondzik  
Roger L. Hedrick  
Srinivas Katipamula  
Rick A. Larson  
Lawrence C. Markel  
Arsen K. Melikov  
Mark P. Modera  
Cyrus H. Nasser

Heather L. Platt  
David Robin  
Peter Simmonds  
Dennis A. Stanke  
Wayne H. Stoppelmoor, Jr.  
Jack H. Zarour  
Julia A. Keen, *BOD ExO*  
James K. Vallort, *CO*

Stephanie C. Reiniche, *Senior Manager of Standards*

---

**SPECIAL NOTE**

This American National Standard (ANS) is a national voluntary consensus Standard developed under the auspices of ASHRAE. *Consensus* is defined by the American National Standards Institute (ANSI), of which ASHRAE is a member and which has approved this Standard as an ANS, as “substantial agreement reached by directly and materially affected interest categories. This signifies the concurrence of more than a simple majority, but not necessarily unanimity. Consensus requires that all views and objections be considered, and that an effort be made toward their resolution.” Compliance with this Standard is voluntary until and unless a legal jurisdiction makes compliance mandatory through legislation.

ASHRAE obtains consensus through participation of its national and international members, associated societies, and public review.

ASHRAE Standards are prepared by a Project Committee appointed specifically for the purpose of writing the Standard. The Project Committee Chair and Vice-Chair must be members of ASHRAE; while other committee members may or may not be ASHRAE members, all must be technically qualified in the subject area of the Standard. Every effort is made to balance the concerned interests on all Project Committees.

The Senior Manager of Standards of ASHRAE should be contacted for

- a. interpretation of the contents of this Standard,
- b. participation in the next review of the Standard,
- c. offering constructive criticism for improving the Standard, or
- d. permission to reprint portions of the Standard.

**DISCLAIMER**

ASHRAE uses its best efforts to promulgate Standards and Guidelines for the benefit of the public in light of available information and accepted industry practices. However, ASHRAE does not guarantee, certify, or assure the safety or performance of any products, components, or systems tested, installed, or operated in accordance with ASHRAE’s Standards or Guidelines or that any tests conducted under its Standards or Guidelines will be nonhazardous or free from risk.

**ASHRAE INDUSTRIAL ADVERTISING POLICY ON STANDARDS**

ASHRAE Standards and Guidelines are established to assist industry and the public by offering a uniform method of testing for rating purposes, by suggesting safe practices in designing and installing equipment, by providing proper definitions of this equipment, and by providing other information that may serve to guide the industry. The creation of ASHRAE Standards and Guidelines is determined by the need for them, and conformance to them is completely voluntary.

In referring to this Standard or Guideline and in marking of equipment and in advertising, no claim shall be made, either stated or implied, that the product has been approved by ASHRAE.

**CONTENTS**  
**ANSI/ASHRAE Standard 110-2016,**  
**Methods of Testing Performance of Laboratory Fume Hoods**

<b>SECTION</b>	<b>PAGE</b>
Foreword .....	2
1 Purpose.....	3
2 Scope.....	3
3 Definitions and Abbreviations.....	3
4 Instrumentation and Equipment .....	6
5 Test Conditions .....	13
6 Face Velocity Measurement Procedure .....	14
7 Flow Visualization Procedure .....	16
8 Tracer Gas Test Procedure.....	17
9 References.....	18
10 Informative Appendix A: Commentary and Additional Information on Standard 110 Sections .....	19
11 Informative Appendix B: Diagnostic Use of this Standard.....	26
12 Informative Appendix C: Example Report .....	30
13 Informative Appendix D: Bibliography .....	31

**NOTE**

**Approved addenda, errata, or Interpretations for this standard can be downloaded free of charge from the ASHRAE website at [www.ashrae.org/technology](http://www.ashrae.org/technology).**

**© 2016 ASHRAE**

1791 Tullie Circle NE · Atlanta, GA 30329 · [www.ashrae.org](http://www.ashrae.org) · All rights reserved.

ASHRAE is a registered trademark of the American Society of Heating, Refrigerating and Air-Conditioning Engineers, Inc.  
ANSI is a registered trademark of the American National Standards Institute.

(This foreword is not part of this standard. It is merely informative and does not contain requirements necessary for conformance to the standard. It has not been processed according to the ANSI requirements for a standard and may contain material that has not been subject to public review or a consensus process. Unresolved objections on informative material are not offered the right to appeal at ASHRAE or ANSI.)

## FOREWORD

First published in 1985 and revised in 1995, ASHRAE Standard 110 provides a method of testing the performance of laboratory fume hoods. This revised edition has been expanded in a number of significant ways:

- The test procedures now require digital collection of data rather than allowing manual data collection.
- Some modifications have been made to the test procedure. These modifications were made based on the experience of the committee members or to clarify statements in the 1995 edition of the standard.
- Informative Appendix A, which provides explanatory information, has been expanded.
- Informative Appendix B, a new nonmandatory section, provides guidance to anyone using the standard as a diagnostic tool in investigating the cause of poor hood performance.

The aim of this standard is to provide a test that takes into account the wide variety of factors that influence the performance of laboratory fume hoods. The ability of a laboratory hood to provide protection for the user at the face of the hood is strongly influenced by the aerodynamic design of the hood, the method of operation of the hood, the stability of the exhaust ventilation system, the supply ventilation of the laboratory room, the work practices of the user, and other features of the laboratory in which it is installed. Therefore, there is a need for a test method that can be used to evaluate the performance of a laboratory hood in the ideal environment and in the field to establish an "as used" performance rating, including the influences of the laboratory arrangement and its ventilation system.

This standard defines a reproducible method of testing laboratory hoods. It does not define safe procedures. However, laboratory hoods are considered by many to be the primary safety devices in conducting laboratory operations.

There are many important factors in the safe operation of laboratory hoods that are not described in this standard. These include the following:

- **Cross-drafts.** Air currents may, by creating turbulent air pockets, draw contaminants from the hoods. Such cross-drafts could be caused by air supply diffusers or grilles, open windows or doors, or rapid movements of people in front of the hood.
- **Work procedures.** There is substantial evidence to suggest that all work in a hood should be conducted as far back in the hood as practical. Generally, users have standardized the requirement that all work should occur at

least 6 in. (150 mm) behind the face of the hood. However, significantly improved protection can be achieved by working farther than 6 in. (150 mm) from the face of the hood.

- **Internal obstructions.** The location of too much laboratory equipment (bottles, glass, etc.) in the hood will disturb airflow patterns into the hood.
- **The procedure being performed.** The intrinsic hazard of the procedure being performed can affect the level of safety required by the user.
- **Thermal challenge.** Heat produced in the hood can cause significant disturbance in hood performance and even cause leakage of warm and possibly contaminated air from the top of the hood or from behind the sash.
- **Rate of response.** The time interval required for a hood to respond to a change in static pressure in the main exhaust duct serving multiple hoods may affect hood performance.

In summary, there are many factors to consider in evaluating the performance of a laboratory hood installation. This standard provides one tool in evaluating such safety.

This test method presumes a conditioned environment. No test can be devised which would, conducted once or infrequently (for example, annually), reflect the results which would be obtained in an unconditioned laboratory with various conditions of windows, wind velocity, etc.

The procedure is a performance test method and does not constitute a performance specification. It is analogous to a method of chemical analysis, which prescribes how to analyze for a chemical constituent, not how much of the substance should be present. Another analogy would be a method for measuring airflow: the method prescribes how the flow should be measured, not how much it should be.

The desired hood performance should be defined through the cooperative efforts of the user, the chemical hygiene officer, the applications engineer, and other parties affected by the hood performance. It should be noted that the performance test method does not give a direct correlation between testing with a tracer gas and operator exposures. This method of testing is not intended to replace a personal sampling monitoring program. Many factors, such as the physical properties of the material, the rate and mode of evolution, the amount of time the user spends at the face of the hood, and several other factors must be integrated by a trained observer into a complete evaluation of user exposure. The performance test method does, however, give a relative and quantitative determination of the efficiency of the hood containment under a set of specific, although arbitrary, conditions. The same test can be used to evaluate hoods in manufacturer facilities under (presumably) ideal conditions or under some specified condition of room air supply or during the commissioning of a new or renovated laboratory before the user has occupied the laboratory.

This method consists of the following three tests:

- Flow visualization
- Face velocity measurements
- Tracer gas containment

The flow visualization and face velocity tests should always precede tracer gas testing for a thorough evaluation of hood performance. The flow visualization and face velocity tests can be conducted without the tracer gas test as a combination of a quantitative velocity measurement and a qualitative evaluation of hood performance. This portion of the standard could be used in the testing and balancing of new facilities and periodic tests of many hoods at a large facility. The full test procedure (visualization, face velocity, and tracer gas) is a quantitative measurement of a hood's containment ability and is useful for hood development and rigorous evaluation of hood performance.

This standard may be used as part of a performance specification once the required control levels have been set. The desired hood performance should be defined through the cooperative efforts of the hood user, the chemical hygiene officer, the applications engineer, and other parties who may be affected by unsatisfactory fume hood performance. Three alternate ratings can be determined, depending on the condition of the test. An "as manufactured" (AM) test would be conducted at the hood manufacturer's location and would test only the design of the laboratory hood independent of the laboratory environment. An "as installed" (AI) test would be conducted in a newly constructed or renovated laboratory after thorough testing and balancing has been completed but before the user has occupied the laboratory. Consequently, the test would include the influences of the laboratory environment, such as the aerodynamic design of the hood, the supply air system, the geometry of the room, and the exhaust air system. The final test would be an "as used" (AU) test in which the investigator accepts the hood in the condition in which the user has established the hood. This includes obstructions within the hood, maladjustment of the baffles, thermal challenge within the hood, and other factors.

If this standard is to be used as part of a specification, the following criteria must be specified:

- a. Sash test opening or openings, which should address both the design opening and the typical use openings
- b. Average face velocity
- c. Range of face velocities
- d. Average face velocity for sash at 25% and 50% of the design hood opening
- e. Acceptable smoke visualization tests
- f. Performance rating (as defined in the standard)
- g. Sash movement performance rating
- h. For variable-air-volume (VAV) hoods, the speed of response and the time to steady state
- i. For auxiliary air hoods, the percentage of auxiliary air supply
- j. Special conditions or tests

This standard does not constitute an engineering investigation of what the causes may be for poor performance or of ways to improve the performance. The test may, of course, be used as an aid to such an investigation. Informative Appendix B addresses some possible applications of the test procedure as a diagnostic tool.

The test protocol provides for the hood sash to be placed at the design opening. Because operation of the hood may be

with the sash opened beyond the design criteria, it is prudent to also conduct the tests with the hood full open to test potential conditions of misuse.

A properly designed hood installed in a properly designed laboratory may still be misused. For example, the user may have the hood too full of laboratory equipment or may be using the hood for storage space. The possibilities are too varied to specify in any detail. Therefore, the test procedure is to be conducted on the hood "as is." The equipment in the hood should be operating normally.

Although the test uses a tracer gas to evaluate the performance of laboratory hoods, the procedure is valid when the contaminant is a particulate. Fine dust, small enough to be of health significance, will be carried along with the hood air currents in a fashion similar to the transport of a gas. However, the test is not applicable to operations where the contaminant is released violently, such as particulates from some types of grinding operations or gases from a high-pressure tubing leak. These conditions are abnormal, and a typical or "standard" laboratory hood may not be appropriate for such operations or conditions.

The performance test method may be used to evaluate an auxiliary air hood. It does not attempt, nor is it intended, to measure the ability of the hood to capture the auxiliary supply air.

It is important to evaluate the performance of the laboratory hood under dynamic conditions. This performance test method may be modified to evaluate a dynamic challenge. Specific operations, such as a pedestrian walking past the hood, laboratory doors opening, and specific actions at the hood, are only a few of the challenges that could be expected at the hood. This test method addresses only the dynamic challenge of sash movement. VAV hoods place a significant emphasis on the sash movement and the potential effect on hood performance. However, some constant-volume hoods may also experience a decrease in protection when the sash is moved.

## 1. PURPOSE

The purpose of this standard is to specify a quantitative and qualitative test method for evaluating fume containment of laboratory fume hoods.

## 2. SCOPE

2.1 This method of testing applies to conventional, bypass, auxiliary air, and variable-air-volume (VAV) laboratory fume hoods.

2.2 This standard is intended primarily for laboratory and factory testing but may be used as an aid in evaluating installed performance as well.

## 3. DEFINITIONS AND ABBREVIATIONS

3.1 **Definitions.** This section defines the following terms as they are used in this standard. For the definitions of other terms used in this standard, refer to *ASHRAE Terminology of Heating, Ventilation, Air Conditioning, & Refrigeration*.<sup>1</sup>

**air-supply fixtures:** devices or openings through which air flows into the laboratory room. For the purpose of this standard, all accessories, connecting duct adapters, or other mounting airways shall be considered part of the supply fixture and reported as a unit or an assembly. Some specific supply fixtures are defined as follows:

**diffuser:** an outlet designed to mix supply air and room air and to distribute it in varying directions.

**grille:** a louvered or perforated face over an opening.

**perforated ceiling:** a ceiling with perforated panels used to distribute the air uniformly throughout the ceiling or a portion of the ceiling. Filter pads may be used to achieve a similar result.

**register:** a combination grille and damper assembly.

**auxiliary air:** unconditioned or partially conditioned supply or supplemental air delivered to a laboratory at the laboratory fume hood to reduce room air consumption.

**control level:** the average measured concentration of tracer gas, in parts of tracer gas per million parts of air by volume (ppm) that is not exceeded at the hood face with a 4.0 Lpm (67 mL/s) release rate.

**design opening:** the position of the sash at which the design team assumes that the hood will be operating. The design opening is critical for determining the volumetric flow through the laboratory hood.

**face velocity:** the average velocity of air moving perpendicular to the hood face, usually expressed in feet per minute (fpm) or meters per second (m/s).

**fume hood system:** an arrangement consisting of a fume hood, its adjacent room environment, and the air exhaust equipment, such as blowers and ductwork, required to make the hood operable.

**hood face:** the plane of minimum area at the front portion of a laboratory fume hood through which air enters when the sash is or sashes are full opened, usually in the same plane as the sash for a hood with a vertical sash. For hoods with horizontal sashes, combination sashes, or multiple vertical sashes, the hood face is the plane corresponding to the surface of the outer-most sash panel.

**laboratory hood (sometimes referred to as a fume hood):** a box-like structure enclosing a source of potential air contamination, with one open or partially open side, into which air is moved for the purpose of containing and exhausting air contaminants. A laboratory hood is generally used for bench-scale laboratory operations but does not necessarily involve the use of a bench or table. Figure 3.1 shows the major components of a typical laboratory hood. Although the test in this standard is written for a benchtop laboratory hood, other applications are discussed in Informative Appendix A.

**lazy airflow:** an airflow problem in a hood that is revealed when the smoke generated in a smoke challenge remains on the work surface without smoothly flowing to the back baffle. Figure 3.2 shows an example of lazy airflow.

**maximum opening:** the position of the sash at which the hood has the largest opening.

**operating opening:** the position of the sash at which the hood user places the sash while working at the face of the hood.

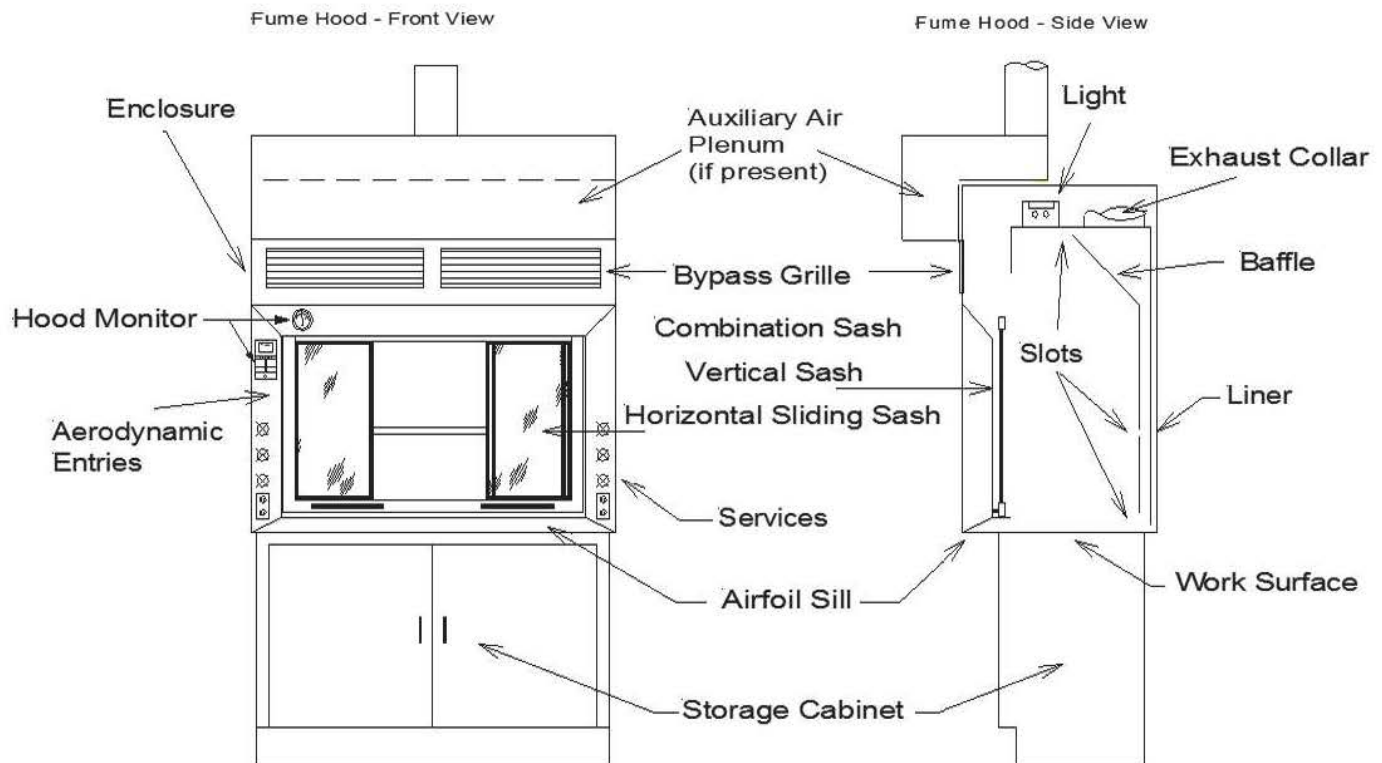

FIGURE 3.1 Components of a typical bench top laboratory hood.



**FIGURE 3.2** Lazy airflow as demonstrated by smoke visualization.



**FIGURE 3.3** Reverse airflow as demonstrated by smoke visualization.

The operating opening should take into consideration ergonomics and all of the procedures to be conducted in the hood. There may be more than one operating opening.

**performance rating:** a rating designated by a series of letters and numbers consisting of the letters AM, AI, or AU and a two- or three-digit number:

AM yyy

AI yyy

AU yyy

where

AM identifies an “as manufactured” test, that is, the laboratory hood is built and assembled by the manufacturer and testing is performed at the factory.

AI identifies an “as installed” test, that is, the laboratory hood is installed at the location of the customer. The hood is tested empty, but with the ventilation system in the installation balanced and the hood in its final location.

AU identifies an “as used” test, that is, the test is conducted after the hood has been installed and used by the chemist. The typical equipment remains in the hood and other activities in the laboratory continue.

yyy is the control level of tracer gas established by the test in ppm.

A test rating of AU 0.5, for example, indicates that the hood as used controls leakage into the laboratory to 0.5 ppm at the mannequin’s sensing point with a tracer gas release rate of 4.0 Lpm (67 mL/s). (This release rate is specified in Section 4.1.)

**positional control level:** the average tracer gas concentration at a position during a test.

**release rate:** the rate of release, in actual litres per minute (Lpm [mL/s]), of tracer gas during a hood test. (See Section 4.1.)

**reverse flow:** an airflow problem in the hood that is revealed when the smoke released in the hood moves forward toward

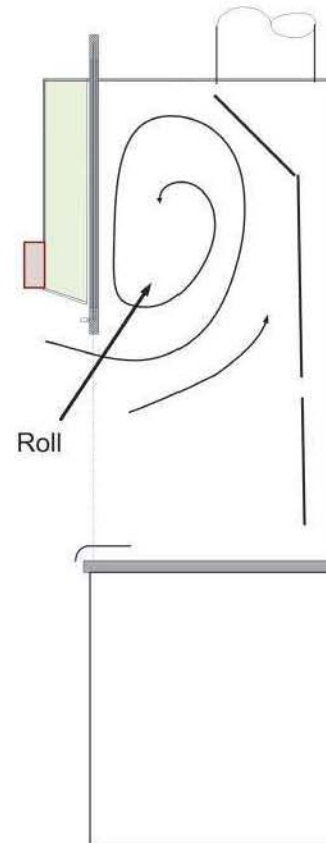

**FIGURE 3.4** Diagram of fume hood showing location of roll in the upper cavity of the hood.

the front of the hood. Figure 3.3 shows an example of reverse flow. This term does not apply to the forward motion of the roll inside the hood that occurs in the upper cavity of the hood above the hood opening or to the cyclonic motion that occurs behind a closed horizontal sash.

**roll:** the rotation of air behind the sash or in the upper cavity of the hood. Figure 3.4 shows an example of roll in the upper cavity of a hood.

**sash movement effect:** the maximum 45-second rolling average of the tracer gas concentration observed during a series of sash movement tests at the center of the hood opening.

**sash movement performance rating:** a rating designated by a series of letters and numbers consisting of the letters SME-AM, SME-AI, or SME-AU and a two- or three-digit number:

SME-AM yyy

SME-AI yyy

SME-AU yyy

where SME means “sash movement effect,” AM means “as manufactured,” AI means “as installed,” AU means “as used,” and yyy is the sash movement effect in ppm. A test rating of SME-AM 10, for example, indicates that the maximum 45-second, rolling-average concentration of tracer gas measured during a sash movement test under the “as manufactured” test, with a tracer gas release rate of 4.0 Lpm (67 mL/s) (as required in Section 4.1), is 10 ppm.

**specified rating:** the hood performance rating as specified, proposed, or guaranteed either in the purchase of the hood or in the design and construction of the laboratory, or both.

**test opening:** the position or positions of the sash(es) at which the hood is to be tested. Normally, the test opening is the design opening, the operating opening, or the maximum opening. Proper selection of the test opening will depend on both the design opening and the operating opening. Because of the time involved in doing multiple equipment setups, the test opening may also be the maximum opening. The specification shall identify the details of the test positions. An example of a specification for a combination sash hood could include three positions with the vertical sash closed and the horizontal windows placed at the left, center, and right. In addition, this hood may be tested with the vertical sash opened to a sash height determined by a sash stop.

**titanium tetrachloride:** a chemical,  $TiCl_4$ , used to generate the white visible fumes required for preliminary testing in laboratory hoods.

**VAV speed of response:** the time, measured from the first movement of the sash, for the VAV system to restore the slot velocity or airflow to 90% of the average steady-state value.

**VAV time to steady state:** the time, measured from the first movement of the sash, for the VAV system to restore and maintain the average slot velocity of airflow between 90% and 110% of the average steady-state value.

### 3.2 Abbreviations

Lpm	litres per minute
mL/s	millilitres per second
ppm	parts of tracer gas per million parts of air by volume

## 4. INSTRUMENTATION AND EQUIPMENT

**4.1 Tracer Gas.** The tracer gas shall be sulfur hexafluoride or a gas of similar molecular weight and stability and shall be supplied from a cylinder capable of maintaining a pressure of

approximately 30 psig (200 kPa [gage]) at the test release rate for at least one hour.

**4.1.1** The tracer gas release rate shall be 4.0 Lpm (67 mL/s). One pound of sulfur hexafluoride will provide 4.0 Lpm (67 mL/s) for approximately 19 minutes at sea level. (One kilogram of sulfur hexafluoride will provide 4.0 Lpm [67 mL/s] for approximately 42 minutes.)

**4.1.2** The tracer gas shall be commercial grade or reagent grade and at least 99% pure.

**4.1.3** Substitution of another tracer gas may be made if the standard tracer gas is deleterious to materials in the hood or the laboratory or if work in the laboratory would lead to significant interference in the detection of the tracer gas. In such cases, the release rate provided shall be equal to that of the standard tracer gas and the detector capabilities shall provide greater sensitivity than required for the presumed control level of the hood being tested.

### 4.2 Ejector System

**4.2.1** The tracer gas ejector system shall be installed as shown in Figures 4.1 through 4.3 (dimensions shown in I-P units) or Figures 4.4 through 4.6 (dimensions shown in SI units).

**4.2.2** The tracer gas is piped to the ejector, and the ejector is equipped with a block valve and a pressure gauge. The tracer gas passes through an orifice, entrains air through the holes in the side of the ejector tube, and disperses through a wire mesh outlet diffuser.

### 4.3 Orifice

**4.3.1** The flow rate of the tracer gas is determined by the upstream pressure and diameter of the orifice. The orifice diameter for sulfur hexafluoride as tracer gas, at a flow rate of 4.0 Lpm (67 mL/s) and a nominal upstream pressure of approximately 30 psig (200 kPa [gage]), is 0.025 in. (0.64 mm).

**4.3.2** Although the orifice diameter and pressure will determine the approximate flow rate, the actual flow rate shall be measured.

**4.3.3** The ejector system release rate shall be verified immediately before beginning a testing session and immediately following the changing of an orifice plate.

### 4.4 Detection Instruments

**4.4.1** The detector instrument shall be a continuous-reading instrument specific for the tracer gas.

**4.4.2** The minimum range of detection of the instrument shall be from 0.01 to 20 ppm.

**4.4.3** The accuracy of the instrument shall be  $\pm 10\%$  of the reading or 0.025 ppm, whichever is greater.

**4.4.4** The instrument shall have output capabilities to allow connection to a data logger. The output shall allow for collection of data at a rate of at least once per second for the duration of the test. The data logging function may be integral to the analyzer, or a data output suitable for a connection to an external data logger may be provided.

**4.4.5** The tip of the probe shall be a small tube with an internal diameter less than 0.5 in. (12 mm).

<u>PIECE MARK</u>	<u>DESCRIPTION</u>
A	OUTLET DIFFUSER
B	EJECTOR TUBE
C	UPPER NOZZLE BLOCK
D	LOWER NOZZLE BLOCK
E	PRESSURE GAUGE
F	CRITICAL ORIFICE
G	HARD RUBBER GASKET 3/4" OD, 1/4" ID, 1/16" THK.
H	SPOOL
I	7/8" O.D. x 1/16" THK BRONZE SINTERED METAL FILTER (5 TO 15 MICROMETER POROSITY)
J	HARD RUBBER GASKET - 1/8" OD, 5/8" ID, 1/8" THK.
K	1/4 x 3" LG. HEX HD. CAP SCREWS WITH WASHERS AND NUTS.
L	BLOCK VALVE
M	EJECTOR SUPPORT - 1 1/2 x 1 1/2 x 1/8 ANGLE 2" LG.

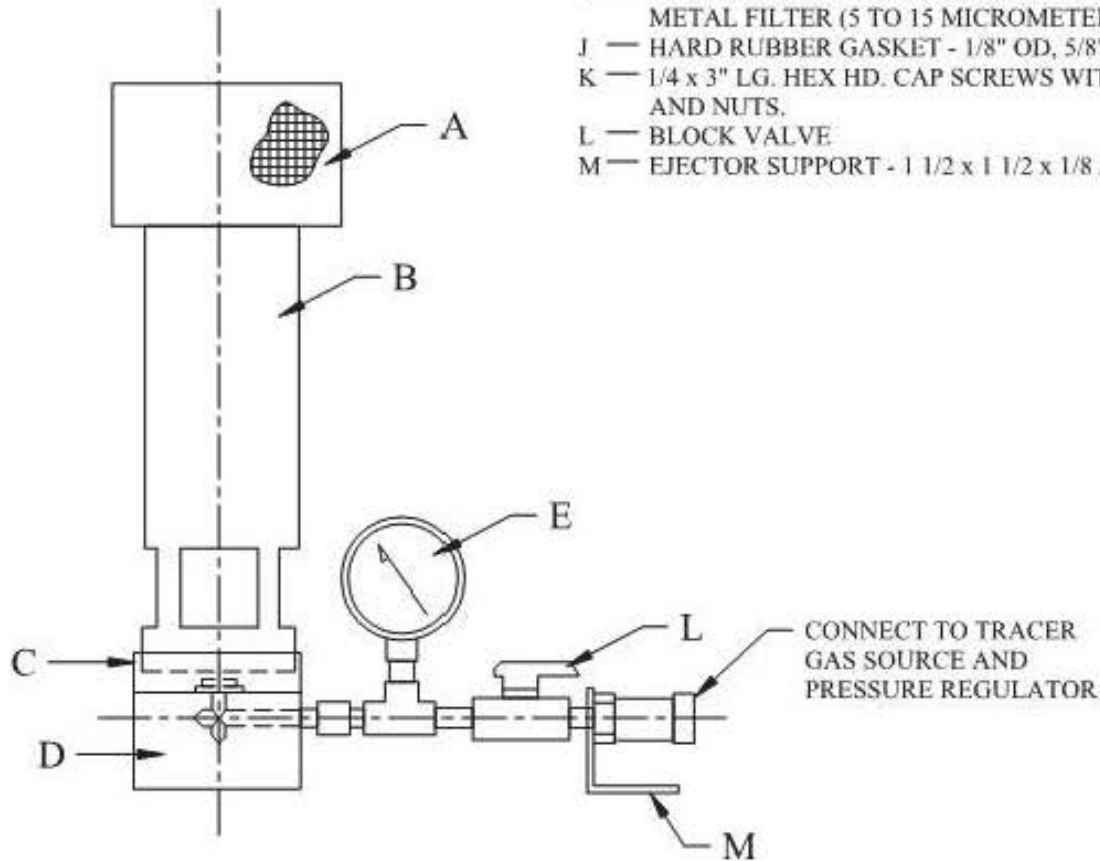

ENJECTOR - GENERAL ARRANGEMENT

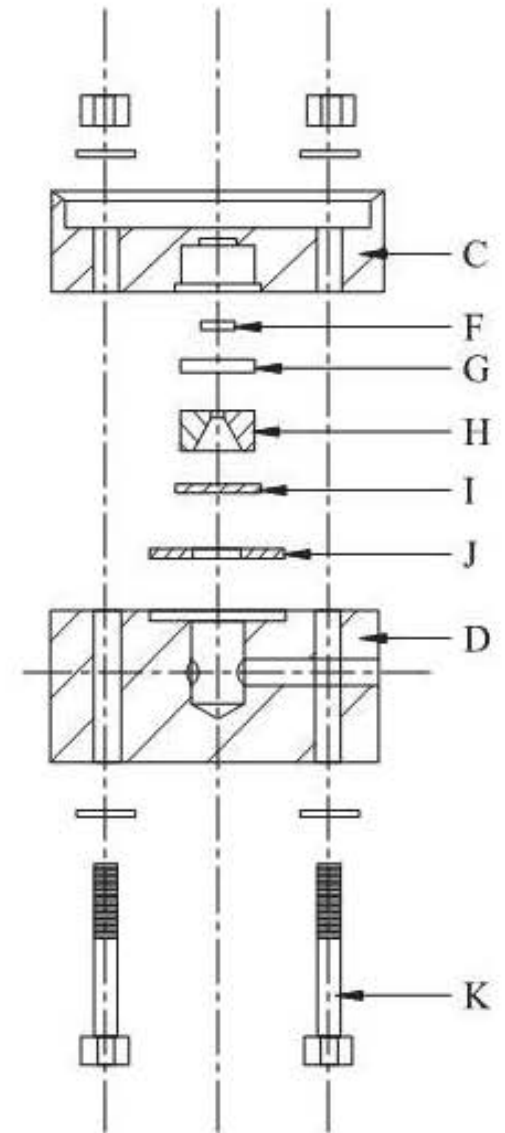

NOZZLE BLOCK ASSEMBLY

**FIGURE 4.1 Ejector assembly, I-P units.**

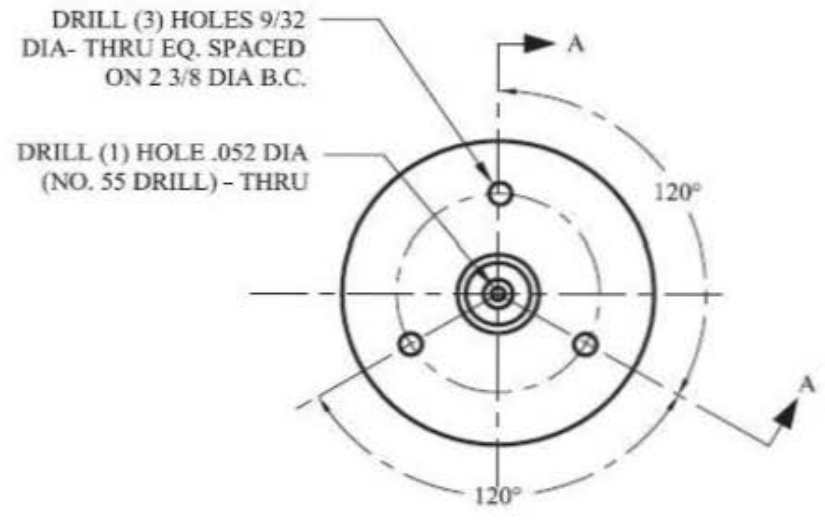
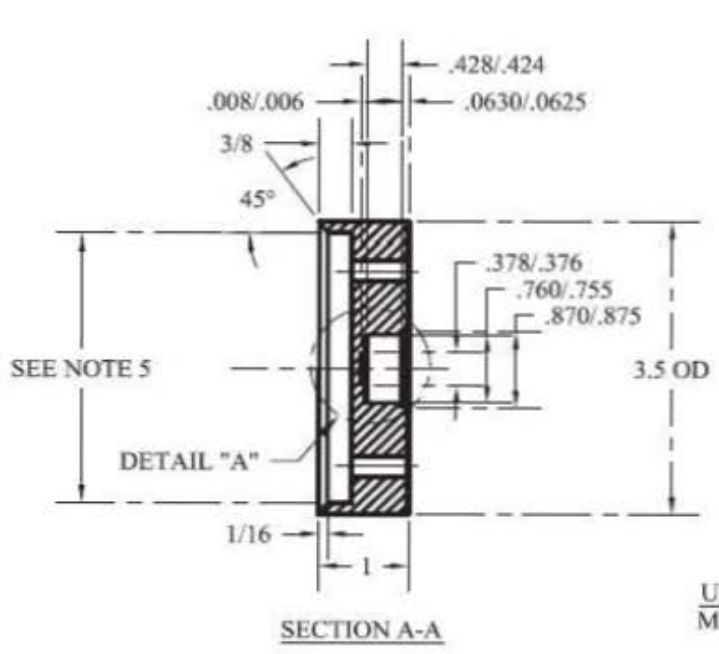

UPPER NOZZLE BLOCK  
MATERIAL: ALUMINUM

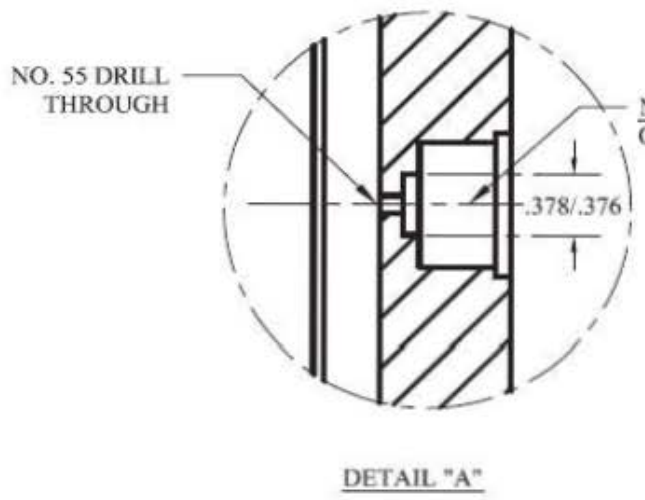

- NOTES**
1. ALL DESIGNATED FINISHED SURFACES TO HAVE 50 MICROINCH MAXIMUM SURFACE ROUGHNESS.
  2. CORNER RADII TO BE 0.010 MAXIMUM.
  3. TOLERANCES:  
 DECIMAL +/- .001  
 FRACTION +/- 1/64  
 ANGLE +/- 1/2°
  4. ALL DIMENSIONS IN INCHES.
  5. BORE SIZE TO BE DETERMINED AFTER RECEIVING MATERIAL FOR EJECTOR TUBE. (SEE EJECTOR TUBE DETAIL) FIND ACTUAL O.D. OF PLASTIC TUBE AND BORE ALUMINUM UPPER NOZZLE BLOCK FOR PRESS FIT ON O.D. OF TUBE.

FIGURE 4.2 Ejector upper nozzle block, I-P units.

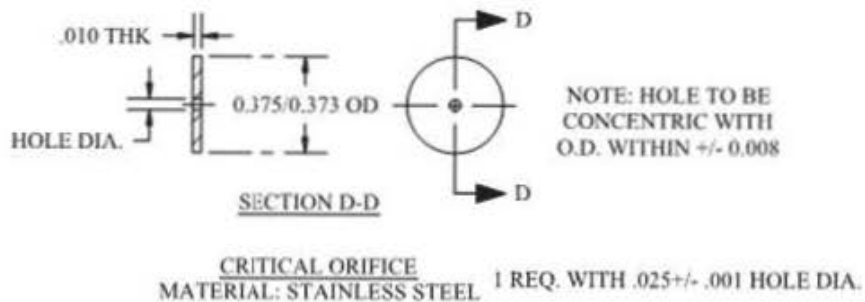
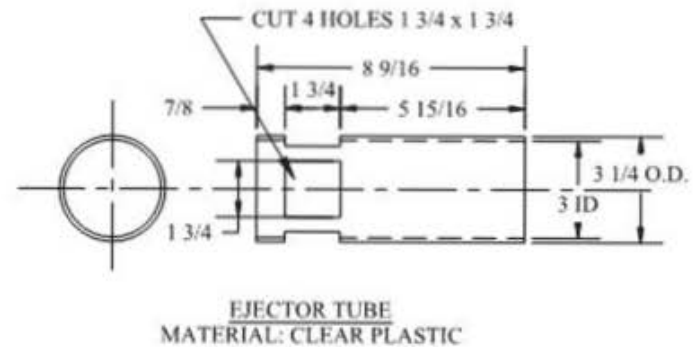
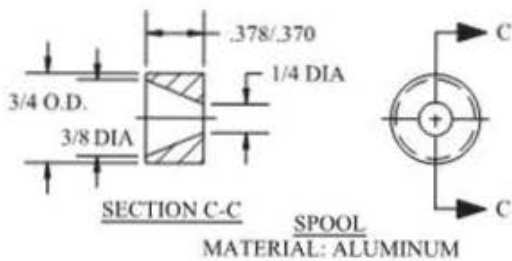
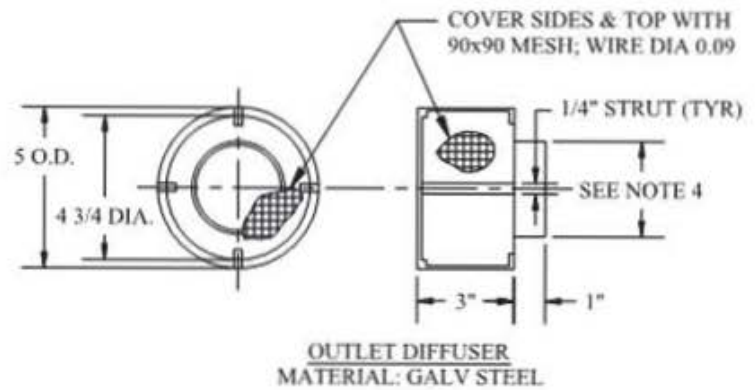
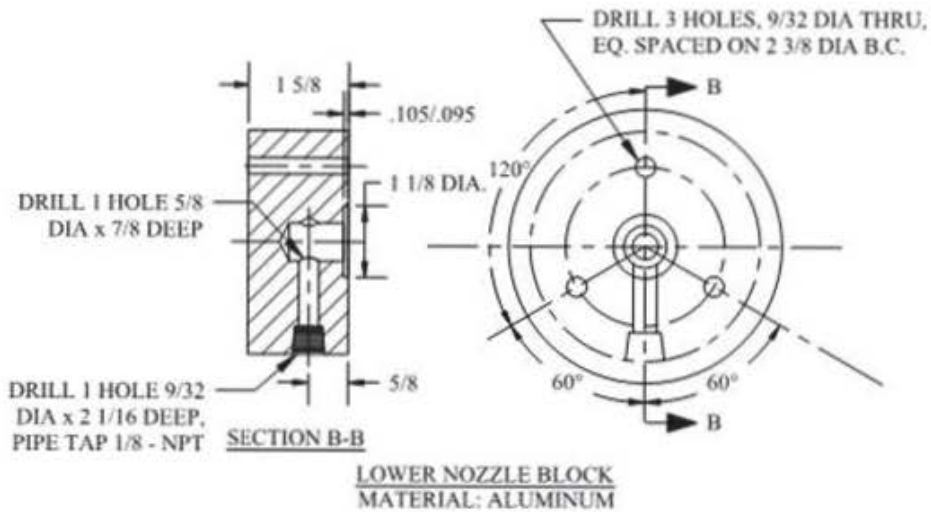

**NOTES:**

1. ALL CORNER RADII TO BE 0.010 MAX.
2. TOLERANCES:  
DECIMAL +/- 0.001  
FRACTION +/- 1/64  
ANGLE +/- 1/2°
3. ALL DIMENSIONS IN INCHES.
4. DETERMINE O.D. AFTER RECEIVING MATERIAL FOR EJECTOR TUBE (SEE EJECTOR TUBE DETAIL). FIND ACTUAL I.D. OF PLASTIC TUBE THEN ALLOW FOR SLIGHT PRESS FIT ON O.D. OF OUTLET DIFFUSER.

**FIGURE 4.3 Ejector details, I-P units.**

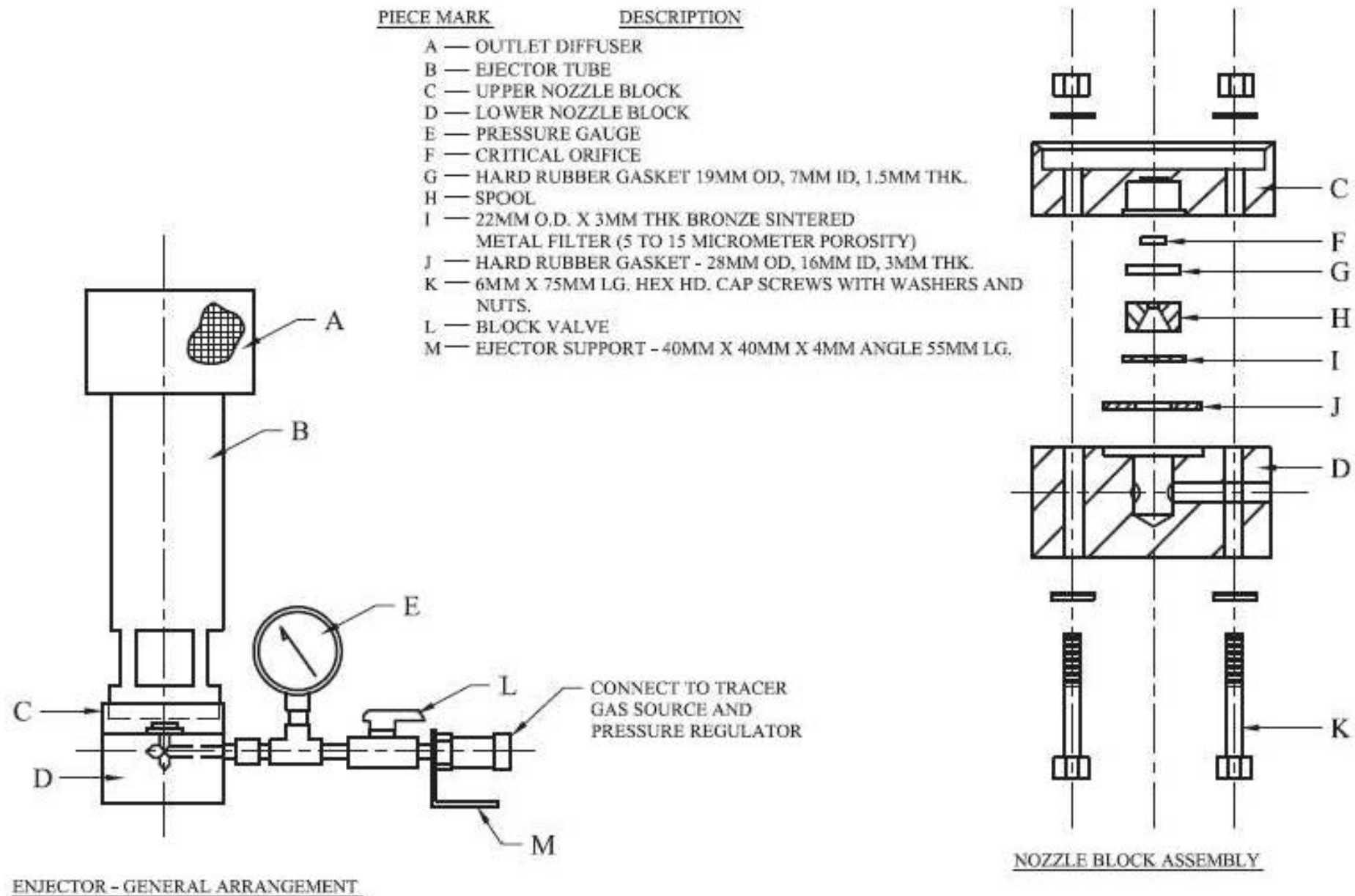
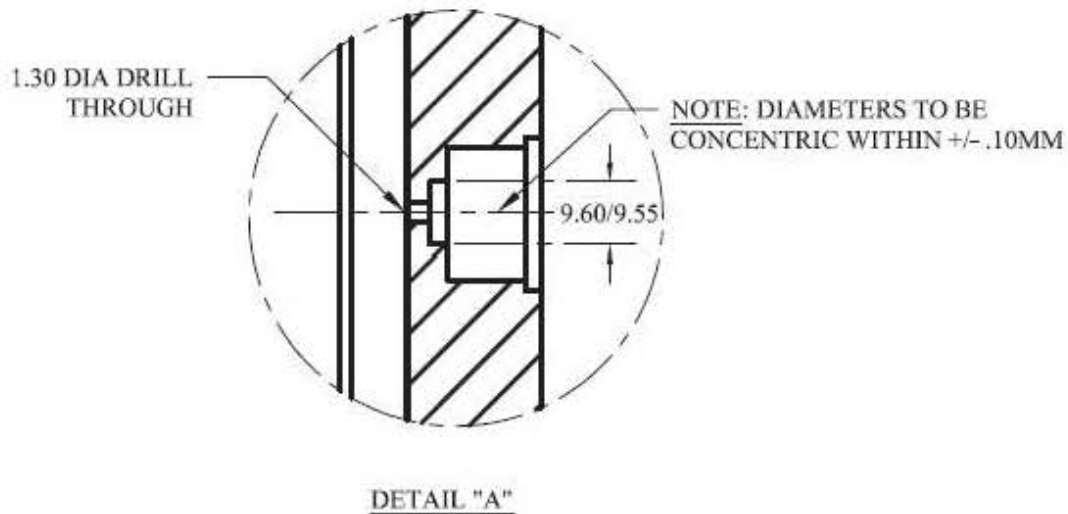
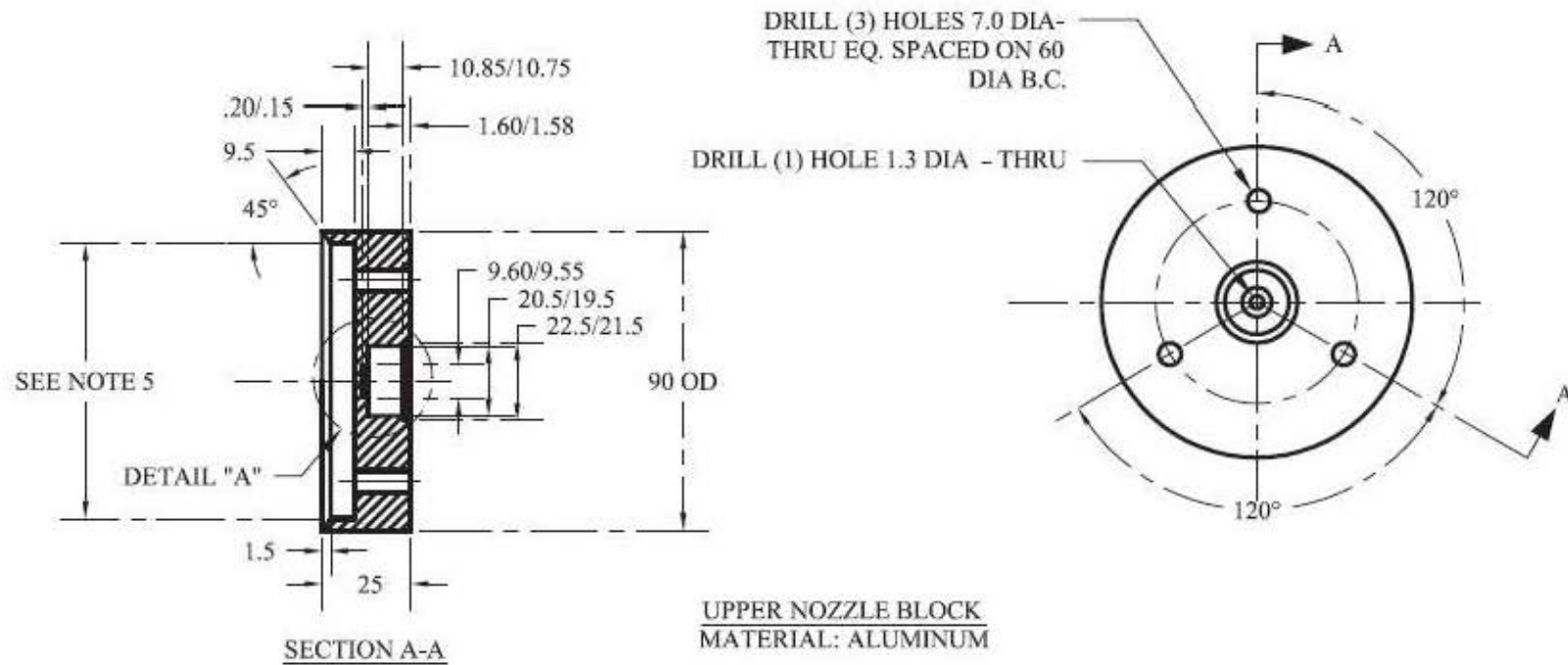

FIGURE 4.4 Ejector assembly, SI units.



#### NOTES

1. ALL DESIGNATED FINISHED SURFACES TO HAVE 1 MICROMETER MAXIMUM SURFACE ROUGHNESS.
2. CORNER RADII TO BE .25MM MAXIMUM.
3. TOLERANCES UNLESS OTHERWISE SPECIFIED:  
DECIMAL +/- .05MM
4. ALL DIMENSIONS IN MILLIMETERS.
5. BORE SIZE TO BE DETERMINED AFTER RECEIVING MATERIAL FOR EJECTOR TUBE. (SEE EJECTOR TUBE DETAIL) FIND ACTUAL O.D. OF PLASTIC TUBE AND BORE ALUMINUM UPPER NOZZLE BLOCK FOR PRESS FIT ON O.D. OF TUBE.

**FIGURE 4.5 Ejector upper nozzle block, SI units.**

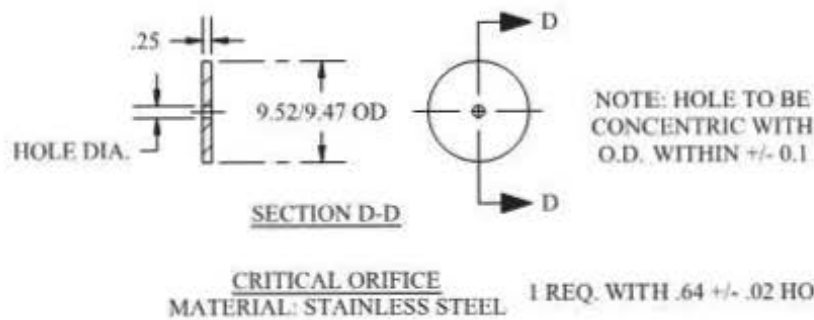
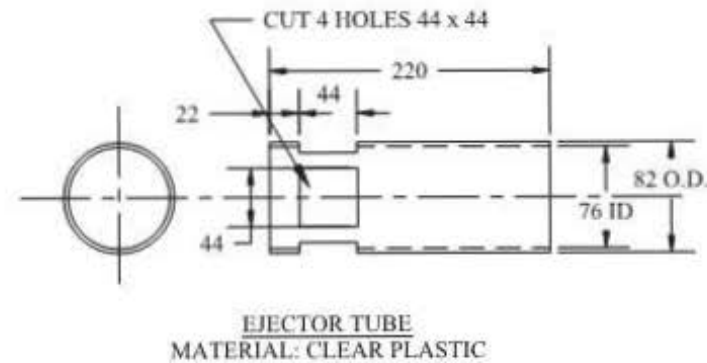
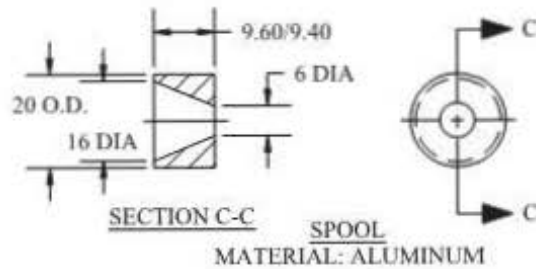
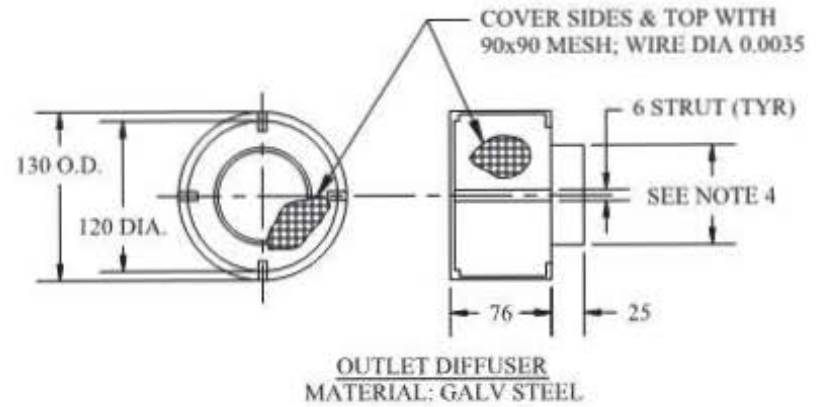
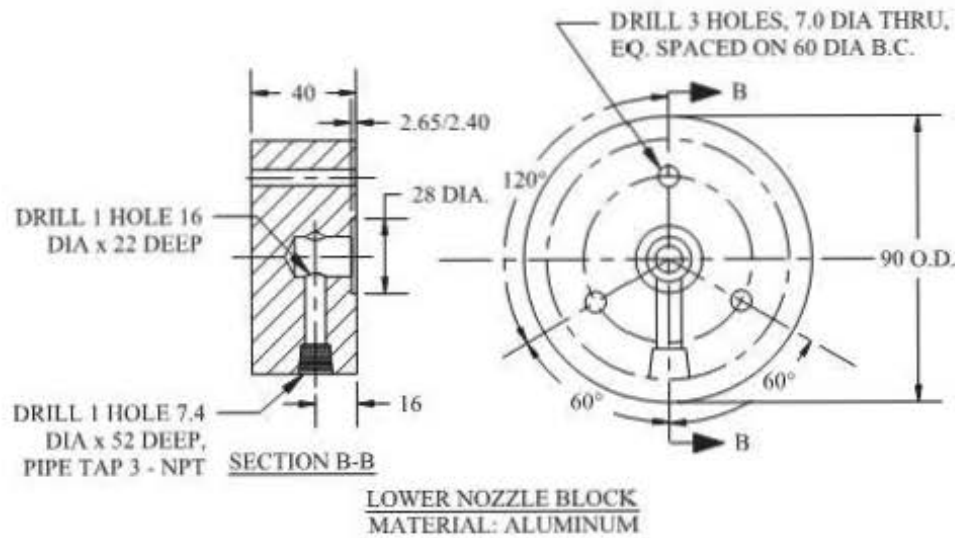

**NOTES:**

1. ALL CORNER RADII TO BE 0.50 MM R.
2. TOLERANCES UNLESS OTHERWISE SPECIFIED +/- 0.05MM
3. ALL DIMENSIONS IN MILLIMETERS.
4. DETERMINE O.D. AFTER RECEIVING MATERIAL FOR EJECTOR TUBE (SEE EJECTOR TUBE DETAIL). FIND ACTUAL I.D. OF PLASTIC TUBE THEN ALLOW FOR SLIGHT PRESS FIT ON O.D. OF OUTLET DIFFUSER.

**FIGURE 4.6 Ejector details, SI units.**

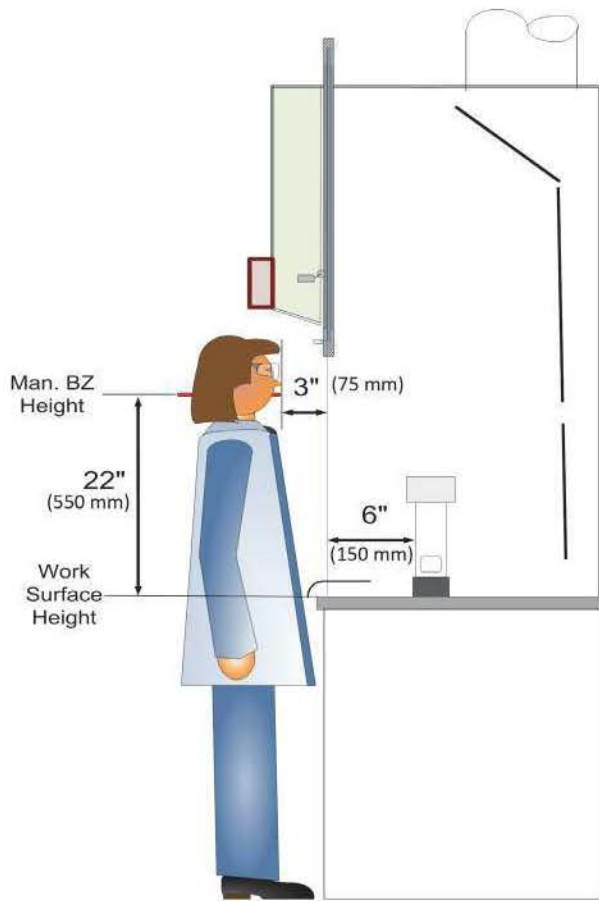

FIGURE 4.7 Mannequin and ejector positions.

#### 4.5 Calibration

4.5.1 The tracer gas detector shall be calibrated with a known concentration of tracer gas at the test site immediately prior to the beginning of a test session and verified after the tests have been taken. In addition, frequent interim verifications are recommended.

4.5.2 The methods of calibration shall be those furnished or specified by the detector manufacturer and shall use the tracer gas as a standard.

4.5.3 If any unacceptable change is detected during the tracer gas detector calibration conducted before and after the test session, the data recorded during that test session shall be considered invalid.

4.6 **Mannequin.** The mannequin shall be a three-dimensional clothing-display mannequin with a shoulder width of  $17 \pm 2$  in. ( $430 \pm 50$  mm). The arms of the mannequin shall hang at its side, and the mannequin shall be of reasonable human proportions. The support shall be designed so that it does not interfere with airflow at the hood while the mannequin is positioned as shown in Figures 4.7 and 4.8. The mannequin shall be clothed either in a smock, coveralls, or a reasonably snug-fitting garment typical of laboratory attire or in the clothing required for the laboratory in which the hood will be used. The mannequin geometry shall allow it to be positioned as described in Section 8.

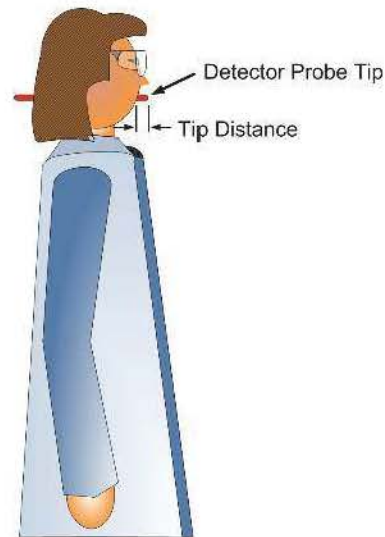

FIGURE 4.8 Probe insertion into mannequin.

#### 4.7 Face Velocity Measuring Instruments

4.7.1 Face velocity measurements shall be made with a recently calibrated thermal anemometer that meets the requirements of ANSI/ASHRAE Standard 111, *Measurement, Testing, Adjusting, and Balancing of Building HVAC Systems*.<sup>2</sup>

4.7.2 The thermal anemometer shall be capable of measuring in the range of 30 to 400 fpm (0.15 to 2.0 m/s) with an accuracy of  $\pm 3\%$  of reading or  $\pm 3$  fpm (0.15 m/s), whichever is greater.

#### 4.8 Airflow Visualization

4.8.1 **Local Generation.** Visible “smoke” shall be produced by smoke bottles, smoke tubes, smoke sticks, or other means. This smoke shall be able to show airflow patterns within the hood without generating such volume or momentum that it affects the ability to make observations.

**CAUTION:** Some sources of smoke contain titanium tetrachloride, which is corrosive and irritating. Avoid skin contact or inhalation. In addition, take care when using titanium tetrachloride to minimize its corrosive effects on the hood.

4.8.2 **Large-Volume Generation.** A method of providing a large, visible smoke shall be available. For more information, see Section A4.8.2 in Informative Appendix A. Care is required in interpreting the observations since large-volume smoke generation often produces smoke with sufficient volume and momentum to affect the observations.

4.9 **Miscellaneous.** Miscellaneous auxiliary equipment, such as a tape measure, extension cords, small wrenches, data sheets, or notebooks, shall be provided as needed.

### 5. TEST CONDITIONS

#### 5.1 Room Ventilation

5.1.1 **Field Test Requirements.** Room ventilating systems, both supply and exhaust, including the fume-hood exhaust, shall be in full normal operation.

**5.1.1.1** Airflow systems in the laboratory shall be properly commissioned prior to beginning the test. This includes calibration of airflow controls; calibration of automatic temperature controls; balance of supply air; completion of a duct traverse on the exhaust duct and, if used, on the auxiliary air duct; and completion of an air balance of the total exhaust flow. If the laboratory has standard procedures limiting the number of hoods in use at any one time, the conditions of use corresponding to the standard procedures shall be established.

**5.1.1.2** The temperature of the room shall be typical for laboratory use, nominally 72°F±5°F (22°C±2.7°C).

**5.1.2 Manufacturer's Test Laboratory (AM Testing).** The following additional requirements shall apply when testing in a manufacturer's test laboratory.

**5.1.2.1** The manufacturer's test laboratory shall not have excessive drafts or crosscurrents. Measured crosscurrents in an area 1.5 ft (0.5 m) from the face of the hood shall be no greater than 30 fpm (0.15 m/s).

**5.1.2.2** The manufacturer's test laboratory shall have room pressurization control capable of measuring and maintaining a pressure differential of 0.02 in. of water (5 Pa) below the static pressure outside the test room.

**5.1.2.3** The manufacturer's test laboratory shall have the hood volumetric flow measured in accordance with ASHRAE Standard 41.2, *Standard Methods for Laboratory Airflow Measurement*.<sup>3</sup>

**5.1.2.4** The manufacturer's test laboratory shall have the hood static pressure measured at the exit plane at the top plane of the collar(s) in accordance with ASHRAE Standard 41.3, *Standard Method for Pressure Measurement*.<sup>4</sup>

**5.1.3 Reporting.** The report for an "as manufactured" (AM) test shall include a sketch of the test laboratory that documents the location of the test hood and any equipment that might affect hood performance. In particular, the sketch, or accompanying text, shall identify the location and type of supply fixtures, the supply air system, and the supply air controls (volumetric flow, temperature, pressure, etc.).

## 5.2 Hood Condition

**5.2.1 Sash Position.** The sash or sashes shall be located in the test opening or openings.

**5.2.2 Auxiliary Air Hoods.** If the hood has an auxiliary supply, the supply shall be in operation and maintained at design conditions. If the supply is capable of convenient adjustment by laboratory personnel, the adjustments shall be as specified in the Chemical Hygiene Plan or the contract documents.

## 5.3 Background Level

**5.3.1 Zero Background Test.** Before beginning the testing and frequently during the testing period, verify that the instrument is adequately zeroed.

**5.3.2 Background Tests.** Occasionally during the hood testing, verify that the room background has remained below the detection limit. Background levels of contaminants can be observed if the ventilation system demonstrates reentry or if the laboratory releases compounds that are detected by the instrument.

**5.3.3 Test Results.** If air contaminants are sensed by the detector as tracer gas at more than 10% of the presumed control level, use of such materials shall cease until background readings fall below 10% of the presumed control level. Otherwise, substitution of another tracer gas meeting the requirements of Section 4.1.2 shall be implemented.

## 5.4 Preliminary Data

**5.4.1** Document the conditions of the room. A sketch of the room shall be prepared indicating the location of significant equipment.

**5.4.1.1** Minimum data shall include a general layout of the room and the location(s) of the test hood, other laboratory hoods, local exhaust ventilation, and general exhaust.

**5.4.1.2** Reference to existing drawings may be a sufficient substitute for room sketches if they are readily accessible.

**5.4.2** A sketch of the air supply system indicating the type of supply fixture (grilles, registers, ceiling diffusers, perforated ceiling, or other type) shall be made. Other activities in the room shall be indicated. Information on the number of other laboratory hoods and their condition of operation is required.

**5.4.3** Document the configuration of the hood.

**5.4.3.1** For example, document the hood type and size, sash configurations and opening, presence of an airfoil, sash stops and position of baffle slots, or other significant components.

**5.4.3.2** If there is material in the hood, note the location of material storage, the amount of work-surface space occupied, and any obstructions to the hood opening by materials within the hood.

**5.4.4** Document the test equipment used, including velocity measurement equipment and the tracer gas detector, and note the tracer gas detector sampling rate as well.

## 6. FACE VELOCITY MEASUREMENT PROCEDURE

### 6.1 Face Velocity Measurements

**6.1.1** Form an imaginary grid pattern by equally dividing the design hood opening into vertical and horizontal dimensions. The grid spaces shall be less than 1 ft<sup>2</sup> (0.09 m<sup>2</sup>), and the larger side of the grid rectangle shall not exceed 13 in. (330 mm). Velocity readings shall be taken with a calibrated anemometer fixed at the center of each grid rectangle. The sensing element of the anemometer shall be held in the plane of the hood sash to measure the velocity of the air perpendicular to the sash.

**6.1.2** The anemometer shall be mounted on a movable stand and not handheld.

**6.1.3** The anemometer shall be used to take and record 20 velocity readings, taken at the rate of one per second, at the center of each grid rectangle. Repeat this procedure for each grid rectangle. Calculate the average of the 20 readings for each grid rectangle.

**6.1.4** Stand well away from the opening during measurement to affect the airflow as little as possible.

## Speed-of-Response Test Example

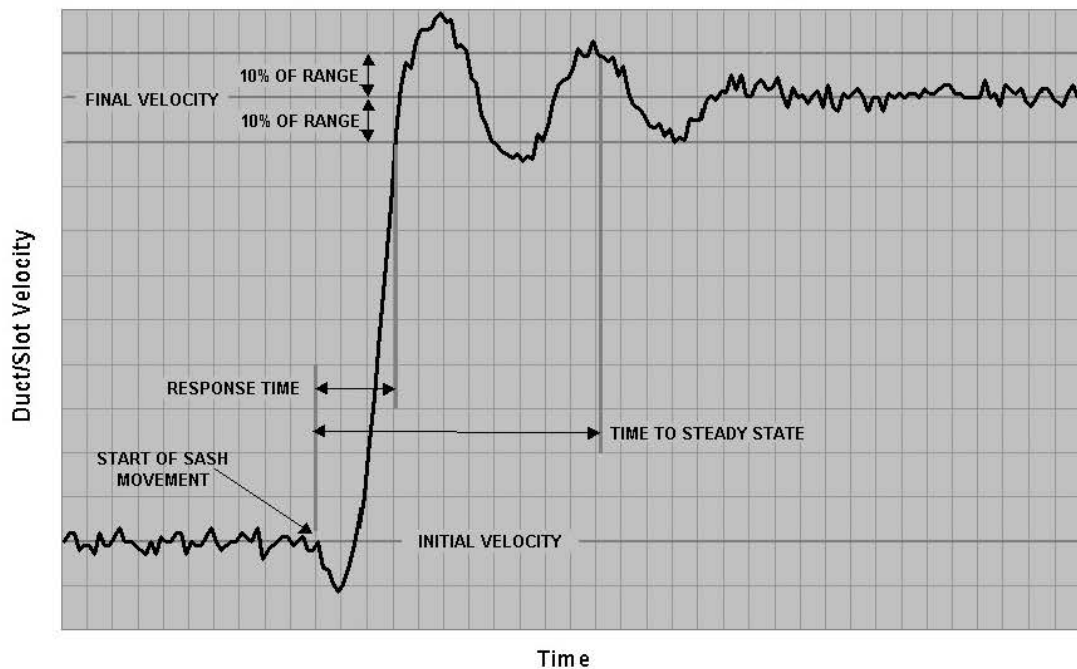

FIGURE 6.1 Graphic representation of the VAV sash movement effect flow test.

6.1.5 The average face velocity is the average of the grid rectangle velocity averages. In addition, record the highest and lowest grid rectangle average velocities.

### 6.2 VAV Face Velocity Control Test

6.2.1 This test is for variable-air-volume (VAV) systems.

6.2.2 Verify that the VAV controls have been calibrated as defined by their manufacturer. This shall include calibration and adjustment of controllers, sensors, and VAV supply and exhaust airflow control devices that are part of the system.

6.2.3 Adjust the sash to 25% of the design hood opening and allow the face velocity to stabilize. Conduct face velocity measurements in the reduced opening as defined in Section 6.1 and record the results.

6.2.4 Adjust the sash to 50% of the design hood opening and allow the face velocity to stabilize. Conduct face velocity measurements in the reduced opening as defined in Section 6.1 and record the results.

6.2.5 Adjust the sash to the design hood opening and allow the face velocity to stabilize. Conduct face velocity measurements in the design hood opening as defined in Section 6.1 and record results. All measurements shall be recorded.

6.2.6 Average face velocities for all sash positions shall be compared with design specifications.

**6.3 VAV Response Test.** This test applies to laboratory hood systems equipped with VAV controls that modulate flow in response to sash movement. Flow response shall be determined by one of two methods: by measuring the exhaust flow (Method A) or by measuring the hood slot velocity (Method B). Measurements shall be recorded at a rate of one reading per second using a data logger while opening and closing the hood sash. Each 5-minute test shall consist of

three cycles of opening and closing the sash. The sash is closed for 30 seconds and opened for 60 seconds during each cycle and closed at the end of the test. The results are analyzed to determine the speed of response, the time to steady state, and the repeatability of flow response.

### 6.3.1 Definitions

6.3.1.1 **VAV speed of response:** the time, measured from the first movement of the sash, for the VAV system to restore the slot velocity or airflow to 90% of the average steady-state value.

6.3.1.2 **VAV time to steady state:** the time, measured from the first movement of the sash, for the VAV system to restore and maintain the average slot velocity or airflow between 90% and 110% of the average steady-state value.

6.3.1.3 **Repeatability:** the relative range (from the minimum value divided by the average value to the maximum value divided by the average value) of the three readings. Because the average velocity is dependent on the probe position, the set of three readings shall be made without moving the probe. **Note:** If the probe is relocated, the resulting average slot velocity may change. However, the response time and the time to reach steady state should be similar.

### 6.3.2 Test Procedure

6.3.2.1 Securely position the sensor in the proper location.

6.3.2.1.1 **Method A:** Use the flow sensor for the building automation system or locate a velocity meter in the centerline of the exhaust duct.

6.3.2.1.2 **Method B:** Mount a velocity probe in a secure stand with the probe located in the bottom of the baffle slot

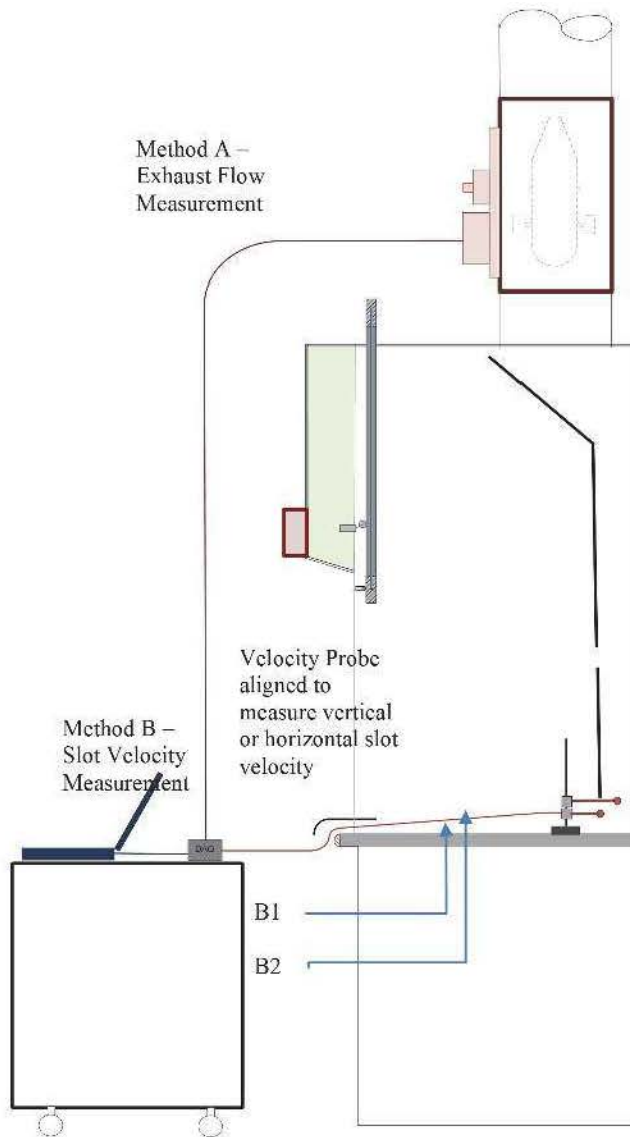

**FIGURE 6.2 Sash movement effect flow test.**

opening using either configuration B1 or B2 shown in Figure 6.2.

**6.3.2.1.3** Some adjustment of the probe location may be required to avoid turbulence.

**6.3.2.2** Close all sashes and record the reading of the laboratory hood monitor.

**6.3.2.3** Begin recording flow at a rate of one reading per second using a data logger. Flow can be represented by pressure or voltage depending on the output from the flow station or the velocity from the velocity probe.

**6.3.2.4** After 30 seconds, open the sash from closed to the design opening at a rate of approximately 1.5 ft/s (0.5 m/s). Record the time corresponding to the beginning of sash movement.

**6.3.2.5** After 60 seconds, close the sash at a rate of approximately 1.5 ft/s (0.5 m/s).

**6.3.2.6** Repeat opening and closing the sash three times.

**6.3.2.7** Determine the speed of response and the time required to reach steady state, in seconds, following the start of sash movement and evaluate the repeatability of flow response.

## 7. FLOW VISUALIZATION PROCEDURE

### 7.1 Flow Visualization

**7.1.1** This test is a visualization of a hood's ability to contain vapors. It consists of both a small local challenge and a large-volume challenge to the hood. The intent of this test is to access the performance of the hood as it is typically used. Because the investigator is often at the face of the hood while performing the tests, care shall be exercised to ensure that the body of the investigator does not influence the smoke visualization. Under ideal conditions, the smoke will flow smoothly, drawn from the point of release toward the slots in the rear baffle.

### 7.2 Airflow Patterns

**7.2.1** The following definitions describe typical airflow problems as demonstrated by smoke visualization.

**7.2.1.1** If the smoke remains on the work surface without smoothly flowing to the back baffle, the airflow is described as "lazy."

**7.2.1.2** If the smoke moves forward toward the front of the hood, the airflow is described as "reverse flow."

**7.2.1.2.1** A minimal amount of reverse flow will nearly always occur at the marine edge of the work surface and is considered normal.

**7.2.1.2.2** Reverse flow does not apply to the forward motion of the roll inside the hood that occurs in the upper cavity of the hood above the hood opening or to the cyclonic motion behind a closed horizontal sash.

### 7.3 Local Visualization Challenge

**7.3.1** Place the sash in the test position.

**7.3.2** Test the operation of the bottom airfoil by releasing smoke from the small smoke source under the airfoil. For a successful test, the smoke shall be exhausted smoothly and not be entrained in the vortex at the top of the hood.

**7.3.3** Discharge a stream of smoke from the small smoke source along both walls and the work surface of the hood in a line parallel to the hood face and 6 in. (150 mm) behind the face of the hood, along the top of the face opening. Carefully observe the action in the corners.

**7.3.4** Release smoke along the work surface.

**7.3.5** While conducting "as used" (AU) tests, release the smoke around the equipment inside the hood. If hot plates or other heat sources are present, observe the influence of the heat sources on the airflow inside the hood. During the test, any lazy or reverse airflow observed may be caused by the equipment and should be noted and documented.

**7.3.6** Release smoke above the bottom of the sash and inside the hood. Observe the airflow behind the sash with specific attention to the airflow as the hood roll meets the bottom of the sash.

**7.3.7** For horizontal sash or combination sash hoods, open the horizontal windows and release smoke along the inside of the sash near the open vertical edge of the sash.

**7.3.8** Release smoke outside the hood. Observe the airflow into the hood and determine whether the room air currents appear to affect the airflow at the hood.

**7.3.9** Release smoke in the cavity above the hood opening. Observe the roll inside the hood. Pay particular attention to the clearance of the smoke, the slots the smoke enters, and any tendency of the roll to follow the inside of the sash toward the opening. Where appropriate, observe the influence of air entering the hood between the sash and the header panel.

## **7.4 Large-Volume Visualization Challenge**

**7.4.1** A suitable source of smoke shall be used to release a large volume of smoke. The release positions shall be the same as for the local visualization challenge in Section 7.3. Extra care in interpreting the observations is required because of the large volume of smoke and the momentum of the smoke. This is especially true when smoke is released outside the hood. Observation of the large-volume smoke release is often best done from the side of the hood face. During an "as used" (AU) test, equipment in the hood, such as heating devices and agitators, shall be operating to determine whether they contribute to leakage.

**7.4.2** Release smoke under the airfoil.

**7.4.3** Release smoke along the sidewalls.

**7.4.4** Release smoke along the work surface.

**7.4.5** If equipment is in the hood, release smoke around the equipment.

**7.4.6** Release smoke inside the hood above the bottom of the sash.

**7.4.7** For horizontal sash or combination sash hoods, release smoke behind the sash.

**7.4.8** Release smoke in the cavity above the hood opening.

**7.4.9** Release smoke outside the hood.

## **7.5 Evaluation of Local and Large-Volume Smoke Tests**

**7.5.1** Airflow patterns shall be observed and noted.

**7.5.2** All of the smoke generated within the hood shall be carried to the back of the hood and exhausted.

## **8. TRACER GAS TEST PROCEDURE**

### **8.1 Tracer Gas Tests**

**8.1.1** The detector shall be turned on and allowed time to equilibrate. Determine the room background. If the background level of contaminants is excessive (see Section 5.3), corrective procedures shall be implemented.

**8.1.2** Immediately before the testing period, periodically during testing, and after completion of the testing, check the detector function by subjecting the detector to a low concentration of tracer gas. If the detector does not respond properly, the hood test shall not be performed until the defect has been corrected. The detector shall always be operated in accordance with the manufacturer's instructions.

**8.1.3** Place the sash at the test position.

**8.1.4** Install the ejector and mannequin at a test position.

**8.1.4.1** For a typical bench-type hood with a vertical sash, three positions are required: left, center, and right (as seen looking into the hood). The left position is with the ejector centerline 12 in. (300 mm) from the left inside wall of the hood, the center position is equidistant from the inside sidewalls, and the right position is 12 in. (300 mm) from the right inside wall.

**8.1.4.2** For each position, place the front of the ejector tube 6 in. (150 mm) from the hood face (see Figure 4.7).

**8.1.4.2.1** When the hood has a single vertical sash, use the plane of the sash as the face of the hood.

**8.1.4.2.2** When the hood has a combination sash or horizontal sashes, the reference point for the measurements shall be the centerline of the horizontal sashes.

**8.1.5** The front edge of the ejector shall be no more than 6 in. (150 mm) behind the front of the work surface.

**8.1.6** To position the ejector, the reference point shall be the front edge of the aluminum barrel of the ejector. The bonnet of the ejector shall extend a nominal 1 in. (25 mm) closer.

**8.1.7** The probe shall be positioned in the breathing zone of the mannequin, with the breathing zone of the mannequin 3 in. (75 mm) from the plane of the sash (see Figure 4.7).

**8.1.7.1** When the hood has a single vertical sash, use the plane of the sash as the face of the hood.

**8.1.7.2** When the hood has a combination sash or horizontal sashes, the reference point for the measurements shall be the centerline of the horizontal sashes.

**8.1.8** If the ejector cannot be positioned 6 in. (150 mm) behind the centerline of the sash, the position of the probe shall also be adjusted. The probe shall be positioned 9 in. (225 mm) from the barrel of the ejector.

**8.1.9** The detector probe shall be fixed in a position with the center of the probe 22 in. (560 mm) above the work surface and 3 in. (75 mm) in front of the sash (see Figure 4.7).

**8.1.10** The detector probe shall penetrate the head of the mannequin exiting at the lips of the mannequin. The probe tip shall extend 0.25 in. (6 mm) beyond the lips of the mannequin (see Figures 4.7 and 4.8). Care shall be taken to ensure that any method of attaching the detector probe to the breathing zone of the mannequin does not interfere with the flow patterns around the mannequin or probe.

**8.1.11** Determine the control level at each test location.

**8.1.11.1** Open the tracer gas block valve.

**8.1.11.2** After a 30-second delay, record for 5 minutes with a reading taken at least every second. The positional control level is the average of the tracer gas concentrations during the 5-minute test.

**8.1.11.3** Relocate the ejector and mannequin to another test position and repeat the measurements for each test position.

**8.1.12** The hood performance rating shall be the maximum of the positional control levels for the three test positions.

**8.1.13** The performance rating of the hood shall be recorded as either AU yyy, AI yyy, or AM yyy, where yyy is the control level in ppm.

## 8.2 Peripheral Scan

**8.2.1** With the mannequin removed from the face of the hood and the block valve open to the ejector, traverse the periphery of the hood openings with the probe. While standing away from the face of the hood, hold the probe 1 in. (25 mm) away from the edge of the hood opening and move it slowly around each opening at a rate of no more than 3 in. (75 mm) per second. Record the locations and values of all concentrations above the instrument's minimum detection level. Care shall be taken to stand to the side of the hood during measurement to affect flow as little as possible.

**8.2.2** Perform a scan with the probe under the airfoil.

**8.3 Sash Movement Containment Test.** The sash movement containment test is conducted to determine the potential for contaminant escape from the hood following movement of the sash. This method is applicable to both constant-volume and VAV hood systems.

**8.3.1** Using the same configuration of the mannequin and tracer gas ejector as was used in the tracer gas tests (see Section 8.1), locate the mannequin and ejector at the center of the hood opening.

**8.3.2** Close the sash or sashes.

**8.3.3** Begin generation of gas at 4.0 Lpm (67 mL/s).

**8.3.4** After 60 seconds, begin recording the tracer gas concentrations at a rate of one sample per second using a data logger.

**8.3.5** After 60 seconds, open the sash from full closed to the design opening at a rate of approximately 1.5 ft/s (0.5 m/s). Note the time corresponding to the beginning of sash movement.

**8.3.6** After 60 seconds, close the sash at a rate of approximately 1.5 ft/s (0.5 m/s).

**8.3.7** Repeat opening and closing the sash three times.

**8.3.8** Close the sash for 30 seconds.

**8.3.9** Calculate the 45-second rolling average for the test. Record the maximum rolling average associated with each opening of the sash.

**8.3.10** The sash movement effect (SME) is the maximum rolling average tracer gas concentration determined. The sash movement performance rating of the hood shall be recorded as SME-AU yyy, SME-AI yyy, or SME-AM yyy, where yyy is the sash movement effect in ppm.

## 9. REFERENCES

- <sup>1</sup> *ASHRAE Terminology of Heating, Ventilation, Air Conditioning, & Refrigeration*, 1991.
- <sup>2</sup> ANSI/ASHRAE Standard 111-2008, *Measurement, Testing, Adjusting, and Balancing of Building HVAC Systems*.
- <sup>3</sup> ASHRAE Standard 41.2-1987 (RA 92), *Standard Methods for Laboratory Airflow Measurement*.
- <sup>4</sup> ASHRAE Standard 41.3-1989, *Standard Methods for Pressure Measurement*.

(This appendix is not part of this standard. It is merely informative and does not contain requirements necessary for conformance to the standard. It has not been processed according to the ANSI requirements for a standard and may contain material that has not been subject to public review or a consensus process. Unresolved objections on informative material are not offered the right to appeal at ASHRAE or ANSI.)

## INFORMATIVE APPENDIX A COMMENTARY AND ADDITIONAL INFORMATION ON STANDARD 110 SECTIONS

The numbered items in this appendix correspond to subsections within the standard for the convenience of the standard's users. For example, Section A1 in this appendix provides further information about Section 1 in the body of the standard. All provisions are to enhance the user's understanding of the subject under discussion as well as of the standard as a whole.

### A1. (PURPOSE)

This standard provides a method of testing the performance of laboratory hoods. It does not provide acceptance criteria. The owner's in-house expert, the chemical hygiene officer, or an industrial ventilation expert should provide the acceptance criteria for the test. The Foreword identifies components of a performance specification, which could become the basis of acceptance criteria.

### A3. (DEFINITIONS)

**air supply fixtures:** The list of air supply fixtures in Section 3, "Definitions," is not intended to be inclusive or complete. The investigator should describe all the fixtures, including their sizes and locations, throughout the test room.

**laboratory hood:** The test procedure is written for a bench-type laboratory hood. If other types of laboratory hoods are used, some modification of the test procedure will be required to reflect the departure from the bench-type hood. For example, the position of the ejector in a large-apparatus (walk-in or floor-mounted) hood must be critically evaluated before the performance test is conducted. In many instances, it would not be appropriate to place the ejector on the floor at the specified distance from the sidewalls or at the centerline.

**test opening:** Selection of the proper test opening is critical. The sash openings should be selected to reflect the position the operator will use. The typical-use opening may be different from the design opening. This is especially true because the design team tends to reduce the opening to conserve energy; as a result, the face velocities at the operating opening may be lower than at the design opening. Because chemists will occasionally open the sash beyond the design or operating position while setting up a procedure while other procedures are active in the hood, it is often advisable to conduct performance tests with the sash in the full-open position.

A good specification will limit the number of test openings. An example of a specification for a combination sash hood could include three positions with the vertical sash closed and

the horizontal windows placed at the left, center, and right. In addition, the hood may be tested with the vertical sash opened to a sash height determined by a sash stop. Testing the performance of a hood with the sash half open in cases where the hood is routinely used with the sash full open can be misleading. Consequently, it is good practice to test the laboratory hood with the sash positioned in a typical configuration. Since the sash can be positioned in an unlimited number of positions, good judgment dictates that the hood be tested in a challenging position. This usually corresponds to the sash being full open.

**A4.1 (Tracer Gas).** Although sulfur hexafluoride is specified as the tracer gas, it may not be possible to use it in some laboratories without disrupting the operation within the laboratory. For example, a laboratory that has been doing trace fluoride analyses may not be able to operate while sulfur hexafluoride is released for hood testing purposes. In such cases, a substitute gas may be appropriate. This gas should be stable, nontoxic, non-odorous, and noncorrosive and have an acceptable minimum detection limit for the detector.

If desired, a different release rate can be selected based on knowledge of the generation rate in the intended use. However, changing the release rate also changes the geometry of the tracer gas challenge.

In some instances, the tracer gas may have a detrimental effect on the system. For example, for a hood with an activated carbon filter, sulfur hexafluoride may reduce the life of the carbon bed or replace toxic materials adhering to the carbon, resulting in an undesirable release.

Although sulfur hexafluoride has many ideal characteristics, it has very high global warming potential. Consequently, this standard's project committee has searched for an alternative tracer gas. To this date, however, none of the gases investigated have proven to be satisfactory.

When investigating alternative tracer gases, two considerations should be evaluated. First, the tracer gas entrains dilution air by aspirating air into the ejector tube. The entrained gas forms a "plume" rising from the ejector, and the volume of the plume is related to the mass flow of the tracer gas. An equivalent tracer gas may require an equivalent volumetric flow in the plume. A lower-molecular-weight gas will form a smaller plume when released at 4.0 Lpm (67 mL/s). Increasing the tracer gas flow rate can provide the same induced flow. However, this brings up the second consideration. The increased tracer gas release rate in the same size plume will result in an increased average concentration of tracer gas in the plume. The higher concentration may warrant a change in the acceptance criteria. For example, if the acceptance criteria are AI 0.10 for sulfur hexafluoride at 4.0 Lpm (67 mL/s) and an equivalent plume is generated with 6 Lpm (100 mL/s) of a new tracer gas, it may be appropriate to change the acceptance criteria to AM 0.15 with 6 Lpm (100 mL/s) of the new tracer gas ( $0.15 = 0.10 \times 6/4$ ).

**A4.2 (Ejector System).** In some instances, it may be appropriate to remotely mount the pressure gage and block valve at the cylinder rather than at the ejector. However, since this will increase the pressure loss through the line, the calibration of the pressure gage and orifice (see Section 4.3.2) should be

conducted with the connecting hose or tube in place. In addition, the required lag time before measurements can be taken may be affected by the remote pressure gage.

The mesh size of the screen influences the plume of gas generated by the ejector. Close adherence to the specification is required.

**A4.3.1 (4.3 Orifice, Subsection 4.3.1).** Other tracer gas flow rates may be achieved by modifying the upstream pressure and/or replacing the orifice plate.

The flow rate of the tracer gas may be measured with a bubble meter. **Note:** Altitude and temperature can affect the actual flow rate.

**A4.4 (Detection Instruments).** In some cases, an alternative method of collection may be used. An air-sampling pump and a gas bag can be used to collect a sample in the breathing zone of the mannequin. The air sample can be analyzed by gas chromatography. This instrument may be used for portions of the standard that require average concentrations to be reported when a comparison between leakage and time is not required. This method determines the average concentration in the breathing zone of the mannequin; however, it does not show the variation in the concentration of the tracer gas, so considerable information may be lost. Moreover, it cannot be used to determine the sash movement effect of the hood.

**A4.5 (Calibration).** The calibration of the detector is critical. Without the detector being adequately calibrated, the results obtained during the testing are of uncertain accuracy, and any conclusions drawn are not supported by reliable data. This is especially important because the test method pushes the instruments to their limits. Although the manufacturers of the instruments provide factory calibrations, these calibrations are not adequate for the purposes of this standard. At a minimum, the detectors should be calibrated before testing begins (at the testing site) and after the end of testing. Because test results collected with improperly calibrated instruments are not valid, frequent calibration during the testing campaign is recommended. This will minimize the amount of data that must be retaken due to inadequate calibration.

**A4.6 (Mannequin).** The standardized mannequin is designed for a standard bench hood. The investigator may use a mannequin that better represents the intended uses of the hood or the requirements of special applications. For example, a handicap hood has different dimensions to accommodate a wheelchair. The mannequin can be modified to simulate a user sitting in a wheelchair at the face of the hood. The torso of the mannequin can be placed in a wheelchair, or the supports can be adjusted to represent the same geometry as would occur with a wheelchair. The critical value would be the height of the centerline of the sensor above the work surface of the hood (22 in. [560 mm]) and the position relative to the hood opening. In a similar way, the mannequin can be modified or adjusted to test walk-in or distillation hoods.

Clothing display mannequins, which are designed primarily to show clothing, may not be capable of being placed in a position typical of a laboratory hood user. In fact, some mannequins cannot be located at the face of the hood as described in Section 8.

**A4.8.1 (Local Generation).** Local smoke generation is intended to trace the airstreams and not to challenge the aerodynamics of the hood. Various means of tracing the flow are available. One means of smoke generation—liquid titanium tetrachloride—can stain the hood and will produce a residue that must be cleaned up. If liquid titanium tetrachloride is used, apply masking tape to surfaces to protect them.

**A4.8.2 (Large-Volume Generation).** There are three generally available methods of generating smoke. First, several manufacturers provide small smoke candles that generate copious smoke. It is important that the smoke generated does not have a large directional component, although in such cases, it is often sufficient to place the candle in a coffee can to dissipate this directional component. In addition, smoke candles can burn the operator or present a potential fire hazard. A second way to generate smoke is with a theatrical smoke generator. A third way is to use dry ice in hot water to generate a visible mist; however, this method does not provide a neutral buoyancy aerosol and so may not be sufficient to demonstrate losses of air from the top of the laboratory hood. (See also Section A6.1.)

**A5.1.3 (Reporting).** The “as used” (AU) test is intended to be conducted within the hood as it is typically used. The exposure to the user at the hood will be dependent on a multitude of factors, including the type of apparatus used in the hood, the use of heat-generating equipment, whether the hood is used as a storage cabinet, and whether the equipment forces the worker to conduct this test too far forward.

**A5.2.1 (Sash Position).** If the hood has a combination sash—that is, a vertically sliding sash with horizontal panels—the hood should be tested in two sash conditions: first, with the vertical sash full closed and the horizontal sashes adjusted to provide a maximum hood opening, and second, with the horizontal panels positioned to the side opposite the hood from the mannequin location or to both sides when the mannequin is located in the center. This will provide the maximum face opening directly in front of the mannequin. In addition, the hood should be tested at the same volumetric flow rate with the vertical sash at the test opening.

When the design documents describe a condition other than a full-open sash, the user may operate the hood with the sash opened beyond the design condition, resulting in a lower face velocity than the design specifies. This could reduce the protection provided by the hood. Thus, in addition to testing the hood at the design opening, the hood may be tested with the sash full open to determine the effect of possible misuse of the hood.

Various sashes and sash positions are shown in Figure A.1.

If a hood is provided with variable-air-volume (VAV) control, the hood should be tested at the appropriate sash position or positions after the VAV control has equilibrated to provide constant volumetric flow. Prior to testing the hood, a velocity profile is required to ensure that the VAV system has adequate capacity to provide the predetermined face velocity.

If the hood has a horizontal sash, the sash should be positioned so as to obtain the maximum face opening of the hood and so that the sash is remote from the section of the hood being tested (left, center, or right). See Figure A.1. If the max-

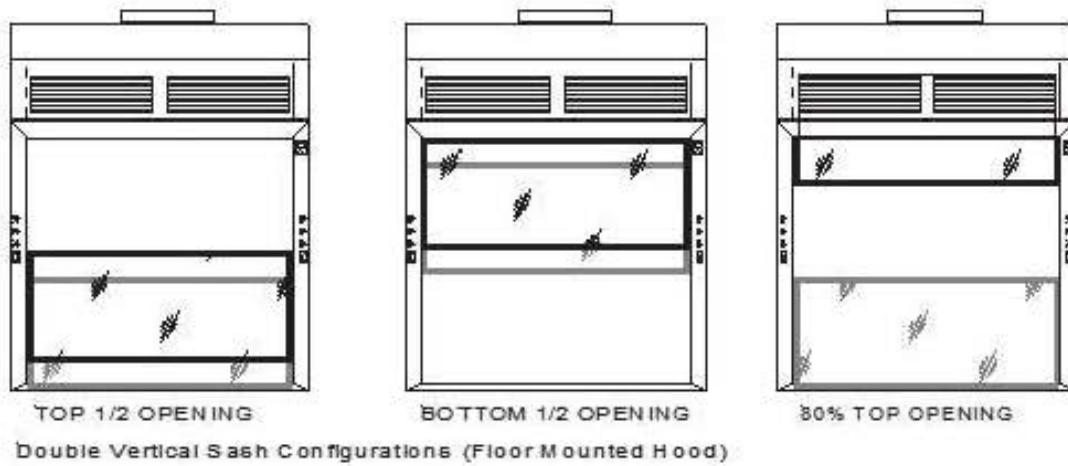
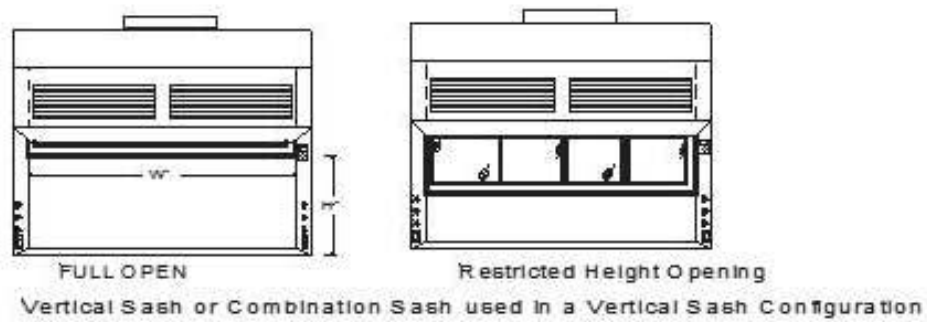

**FIGURE A.1 Sash types and positions.**

imum opening of the horizontal sash hood is 36 in. (900 mm) or less, position the mannequin and ejector in the center of the opening. If the maximum opening is greater than 36 in. (900 mm), position the ejector and mannequin on the right and left sides, 12 in. (300 mm) from the edge of the opening.

**A5.3 (Background Level).** Background levels of contaminants observed by the tracer gas detector can render the test results invalid. To ensure that the test data are valid, background levels should be measured frequently.

**A5.4.2 (5.4 Preliminary Data, Subsection 5.4.2).** The report should include a description of the hood and its contents, including whether the hood is empty or cluttered. If the clutter could affect the test results, the report should specify or describe the clutter.

Adequate data should be taken to allow for future interpretation of the test results. The number of unusual incidences that may occur are too many to be named, but the investigator should be observant and record any unusual situations.

In many instances, the performance of a laboratory hood is affected by both the supply and exhaust systems. Consequently, the tester should be aware of the room airflow, especially the room crosscurrents at or near the hood.

Often it is advisable to include a description of the supply and exhaust systems in the report. This is especially important from a historical perspective. Documenting the ventilation systems can assist in determining the cause of some change in performance. Because cross-drafts can affect the face velocity measurements and hood performance, diagnostic methods of investigating inadequate performance are presented in Informative Appendix B.

In addition to indicating location and type of supply diffusers, attempts should be made to measure the residual velocity in the direction of the hood opening and to document cross-drafts at the face of the hood.

**A5.4.3 (5.4 Preliminary Data, Subsection 5.4.3.1).** Determination of the face opening should include the space between the airfoil and the work surface.

**A5.4.3.2 (5.4 Preliminary Data, Subsection 5.4.3.1).** The location of materials inside the hood, especially in front of the mannequin, may affect the control level.

**A6.1 (Face Velocity Measurement Procedure).** In some hoods, there is considerable variation in the velocity readings at a fixed position. When the variations exceed 15%, the range of variability should be recorded and the average used in the computation of the face velocity. Wide variations could be an indicator of room air currents or poor hood aerodynamic design that may negatively affect hood performance.

The procedure in this standard determines the face velocity of the laboratory hood but does not address the total volumetric flow through the hood or the total volumetric flow requirements at the exhaust fan. Leakage through the bypass, behind the hood sash, and through the hood itself and duct leakage can have significant impacts on the total exhaust flow; however, these factors are not addressed in this test procedure. To determine these values, a volumetric measurement of the kind described in ASHRAE Standard 41.2-1987 (RA 1992)—a Pitot traverse—would be required.

When measuring the face velocity of an auxiliary air hood, the auxiliary airflow changes the face velocity produced by the hood exhaust. ANSI/AIHA Z9.5-2003, *Laboratory Ventilation*, states in Paragraph 5.11.2, “the face velocity of the hood shall be determined with the supply air [auxiliary air] turned off.” When measuring the face velocity of an auxiliary air hood, the condition of the auxiliary air should be noted and recorded.

Some laboratory hoods are designed with a sash plane that is not perpendicular to the flow of the air. If the ventilation measurements are taken as indicated in Section 6.2.1 of this standard, there may be a bias in the readings because many anemometers are sensitive to the direction of airflow. In such a case, it may be necessary to hold the anemometer perpendicular to the airflow rather than to the sash plane. This resulting velocity corresponds to the projected opening of the hood, not the actual opening.

The orientation of the hot wire is critical. The instrument must be held parallel to the opening of the hood. The intent is to measure the velocity of the air perpendicular to the face opening. A small (greater than 15°) misalignment will cause erroneous readings.

**A6.2 (VAV Face Velocity Control Test).** In conducting “as used” (AU) hood evaluation, it may be advisable to determine the external influence of other activities on the performance of the VAV controller. Because the laboratory pressure may influence the performance of the VAV controller, conduct a tracer gas test while opening and closing the door to the laboratory in such a way that the door movement does not cause a fanning action but does allow pressure equalization with the corridor. Observe whether the controller modifies the hood exhaust rate and whether there is a change in hood performance. Likewise, sash movements in hoods connected to the same exhaust system as the laboratory hood being tested could influence the hood performance. By opening and closing sashes on the other hoods while monitoring the VAV controller and the tracer gas concentration, the potential effect can be determined.

The tests described in this section can be used for constant-volume hoods to determine the effect of the bypass on the face velocity. Some specifications require a maximum velocity as the sash is lowered.

**A7.1 (Flow Visualization).** This standard describes a method of observing smoke within a laboratory hood. The method provides a gross evaluation. If the hood fails to contain smoke, the performance is inadequate and the hood fails. However, containment alone does not describe the hood performance. Because the evaluation is subjective, it is not included in the standard. See Informative Appendix B for further discussion.

The influence of a person at the face of the hood can be significant. Smoke tests, both large and small, can show the effect of a person by placing the mannequin at the hood face.

**A7.4 (Large-Volume Visualization Challenge).** If there is visible smoke flow out of the hood, a tracer gas test should not be performed, as hood leakage of this magnitude may result in elevated laboratory background tracer gas concentra-



**FIGURE A.2** Cylinder diffusion of smoke from smoke generator.

tions that may limit the ability to quantify the performance of the hood.

Smoke generation can produce a visible plume in the exhaust duct. If there is a smoke detector in the exhaust, the large smoke challenge may be sufficient to activate the smoke detector. It may be necessary to contact the fire department and possibly the local pollution control authority before discharging large quantities of smoke in the hood.

**Smoke Candles:** Some smoke candles generate a jet of smoke that produces an unacceptably high challenge to the hood. To reduce this directional component, the smoke candle should be placed in a small can. The surface of the can could become warm, so the can should be held by a pair of pliers, tongs, or a similar device.

**Theatrical Fog:** The preferred method is the use of theatrical fog or a smoke-generating machine. Both are capable of generating copious visible particulate with reasonable persistence and nearly neutral buoyancy. Some fogs produce an aerosol that dissipates rapidly, leaving a contaminating residue in the hood. The output of the fogger or smoke generator should be directed into the hood by means of a long hose. This allows the investigator to locate the fog or smoke diffuser at any desired location. Since the fog or smoke may have momentum, creating a situation that could lead to an incorrect observation, a diffuser may be required to slow the fog or smoke. A 4 in. (100 mm) diameter vertical tube with equally spaced holes on each side (see Figure A.2) can be used to challenge the height of the face opening. The cylinder diffuser can be located in the same position as the ejector to provide an indication of the airflow patterns at the ejector.

Another diffuser design entails a cylindrical diffuser located on the work surface horizontally. Be aware that the horizontal diffuser may block airflow on the work surface and the discharge velocity may be uncontrolled, creating an excessive challenge to hood containment.

**Mist from Dry Ice:** Dry ice can be used to visualize hood performance while the hood is being subjected to various challenges, such as room traffic and operations within the

hood. The investigator is encouraged to anticipate the use of specific hoods and the peculiarities of installed locations and devise challenges to test with dry ice. When dry ice is used, careful control of the quantities, size of the dry ice, water temperature, and timing of the observations is critical. In addition, the investigator should recognize that the visible mist is not neutral buoyant and tends to “fall” more than other neutral-buoyant sources of smoke. The Dry Ice Procedure is described as follows.

- a. Prepare for the test by weighing dry ice in a beaker and filling a stainless steel bowl with tempered water. The bowl should have a capacity of approximately 3 quarts (3 L) and a diameter of approximately 8 in. (20 cm). The bowl should contain 1 quart (1 L) of water at 110°F (43°C). A 1 cup (250 mL) beaker should be filled with approximately 0.4 lb (200 g) of dry ice. The texture of the dry ice is important, and pellets should be about 0.25 in. (0.75 cm) in diameter to provide the proper sublimation rate.
- b. The bowl containing tempered water should be placed inside the hood and positioned at the center on the face with the front edge of the bowl 6 in. (150 mm) behind the rear edge of the sash. The sash should be full open.
- c. The dry ice pellets contained in the beaker should be deposited into the bowl and the vapor dispersion should be observed. Containment is best observed from the side of the hood face. A release of vapor from the hood that is steady and visual is an indication of failure. No release of vapor past the face of the hood is considered acceptable.
- d. This test should be repeated while challenging the hood by moving across the front, reaching into the hood, and moving the sash. The bowl should be moved closer to the front of the work surface to determine where leakage is most pronounced. Equipment in the hood such as heating devices and agitators should be operated during a test to determine if they contribute to leakage.

**A8.1.3 (8.1 Tracer Gas Tests, Subsection 8.1.3).** Sash design openings, or multiple design opening configurations, are specified for tests, but in many cases it may be reasonable to test the hood with the sash or sashes full open. Often, users will open the sash beyond the design opening. The containment performance of the hood should be evaluated at the typical use condition.

This test method describes the positioning of the mannequin and tracer gas release position based on the assumption that the hood is a benchtop hood with a vertical sash. Because hoods have different types of sashes, it is important to modify the positioning of the mannequin and the ejector based on the expected use or available sash opening configurations. The following discussion provides some guidance; however, other locations may be appropriate for different situations.

For benchtop hoods more than 8 ft (2.5 m) wide, the test should be conducted in at least four locations. For example, position the mannequin and ejector on the left (12 in. [300 mm] from the left side), left-center (12 in. [300 mm] to the left of the hood center line), right-center (12 in. [300 mm] to the right of the hood centerline), and right (12 in. [300 mm] from the right side).

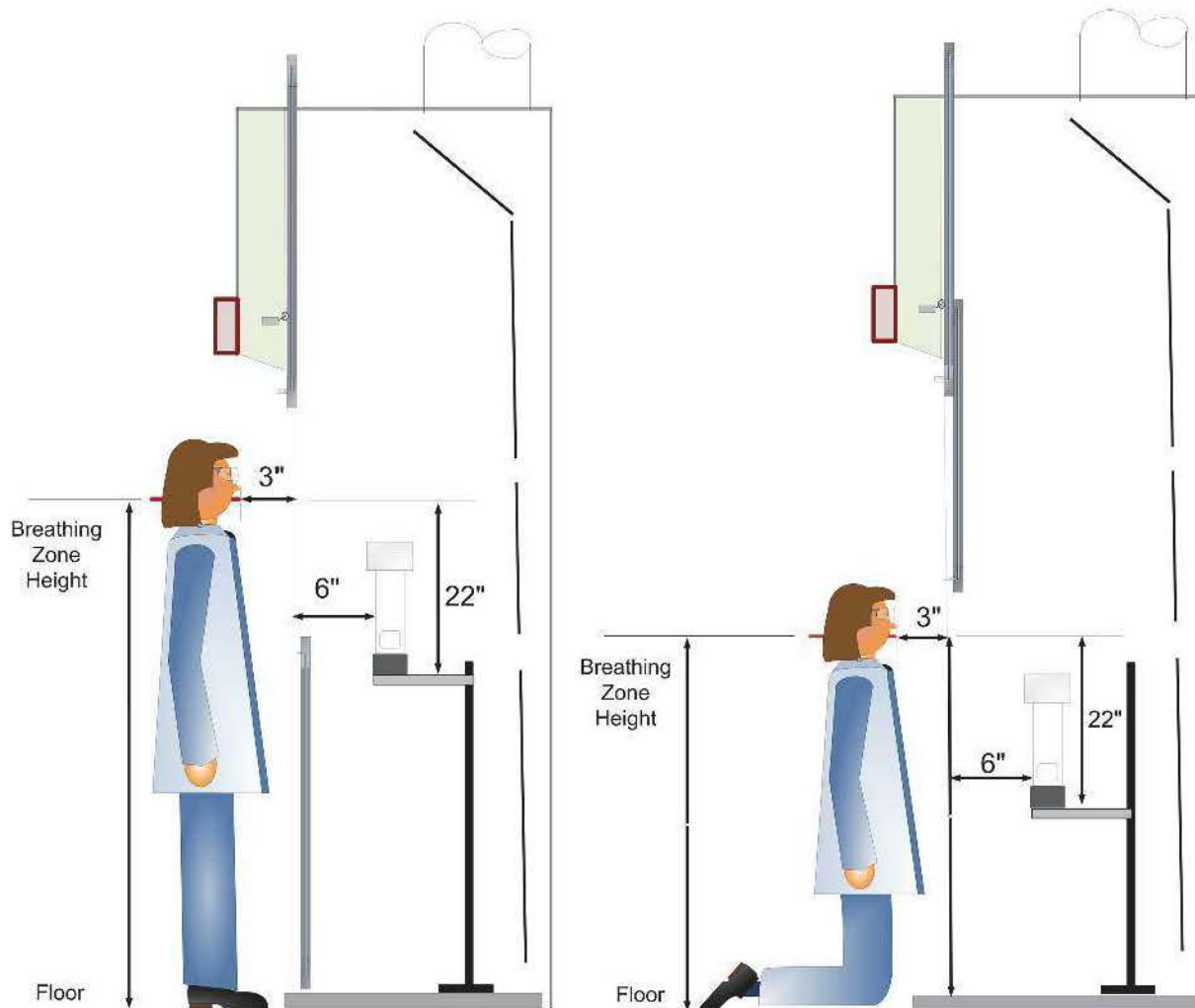

**FIGURE A.3** Positions of mannequin and tracer gas ejector for a floor-mounted fume hood equipped with double vertical sashes.

**Floor-Mounted Hoods:** Floor-mounted hoods are typically equipped with multiple vertical sashes or horizontal sashes. The tests should be conducted with the mannequin and ejector located at two different heights. The ejector should be located on the floor and mounted on a stand with the base of the ejector 36 in. (900 mm) above the floor. The mannequin should be positioned to simulate a person kneeling in front of the opening and standing in front of the opening. See Figure A.3 for test configurations for floor-mounted hoods equipped with double vertical sashes and horizontal sliding sashes. Distillation hoods are tested using the same configurations of mannequin and ejector locations. Table A.1 provides the heights of the mannequin for testing floor-mounted hoods and distillation hoods.

The mannequin and ejector should be located at the left, center, and right test positions as used for a bench hood. All readings are taken with the breathing zone of the mannequin located 3 in. (75 mm) in front of the sash plane. The front of the ejector body should be located 6 in. (150 mm) behind the sash plane.

**A8.1.4 (8.1 Face of the Hood, Subsection 8.1.4).** In the event that the sash is not vertical, the position of the probe and

ejector is to be determined from a vertical plane starting at the bottom of the sash at the operating opening. Some laboratory hoods have a horizontal panel placed in front of the vertical sash that can be placed in front of the chemist as a splash protector. When defining the face of the hood, this horizontal panel should typically be ignored.

**A8.1.5 (8.1 Ejector Test Position, Subsection 8.1.5).** For hoods of unusual dimensions, the location of the ejector may require modifications. Alternative positions are possible and should be clearly identified in the test report. The probe and ejector distances from the sash plane should be as described in Section 8.1.4.

**A8.1.6 (8.1 Detector Probe Positions, Subsection 8.1.6).** If the detector probe design permits, insert the probe through the back of the head of the mannequin so that the air sampled by the probe enters the probe through the approximate breathing zone of the mannequin as shown in Figures 4.7 and 4.8.

The detector probe should be fixed in position and not handheld. An investigator holding the probe could cause, by his/her presence, additional disturbances in airflow that may significantly change the hood performance.

**TABLE A.1 Mannequin Position for Tracer Gas Tests**

Hood Type	Sash Type	Tracer Gas Test <sup>1</sup>	Breathing Zone Height, in. (mm)	AI
Distillation Hood	Multivertical	1	61 (1525 mm)	×
		2	42 (1050 mm)	
Floor-Mounted Hood	Multivertical	1	61 (1525 mm)	×
		2	42 (1050 mm)	
Floor-Mounted Hood	Horizontal	1	61 (1525 mm)	×
		2	42 (1050 mm)	

The test procedure places the probe in the breathing zone of the mannequin. Traversing the face of the hood with the probe or locating the probe, detector, and mannequin independently can obtain additional information on how the hood is performing.

**A8.1.7 (8.1 Tracer Gas Tests, Subsection 8.1.7).** The positioning of the mannequin and the probe height above the work surface can affect the performance of the laboratory hood. A tall mannequin presents a greater blockage to the opening and potentially increased turbulence and eddy formation in front of the mannequin. A shorter mannequin moves the probe closer to the tracer gas plume generated by the ejector. In addition, when the design position for the sash is low, for example, 18 in. (450 mm) above the work surface, the sash can act as a barrier and produce a control level lower than that without the sash. These and other factors may affect the performance tests. Such considerations may warrant additional tests with different mannequin heights and consequently a higher or lower probe position.

**A8.1.8 (8.1 Delayed Beginning, Subsection 8.1.8).** Depending on the assembly of the ejector system and the characteristics of the detector, there is a delay from the start of tracer gas flow until the meter detects any tracer gas present. In addition, the hood may need to reach equilibrium with

the tracer gas challenge; for example, it takes time for the tracer gas to enter the roll within the hood. The standard requires a 30-second delay before collecting tracer gas data. Each test system should be evaluated to ensure that 30 seconds is adequate for the delivery of tracer gas and the instrument response.

**A8.2 (Peripheral Scan).** The peripheral traverse data can be used as a diagnostic tool to determine potential leakage points. There is significant potential for variation in the traverse results due to variation in handheld probe position and speed of traverse.

**A8.3 (Sash Movement Containment Test).** Hood performance may be time dependent due to the lack of steady-state laboratory aerodynamics and thermodynamics. The effect of moving the sash could depend on the state of the system. The result of each test should be recorded. The resulting rating should be clearly distinguished from the hood performance rating since a VAV hood functions as a constant-volume hood most of the time.

The effect of moving the sash is often more pronounced in the center position. However, because of conditions in the laboratory and the design of the supply air system, the appropriate position of the sash movement test may be on the side of the hood.

(This appendix is not part of this standard. It is merely informative and does not contain requirements necessary for conformance to the standard. It has not been processed according to the ANSI requirements for a standard and may contain material that has not been subject to public review or a consensus process. Unresolved objections on informative material are not offered the right to appeal at ASHRAE or ANSI.)

## INFORMATIVE APPENDIX B DIAGNOSTIC USE OF THIS STANDARD

### B1. INTRODUCTION

Although this standard describes a method of testing to evaluate the performance of laboratory hoods, it is not intended as a diagnostic test. However, the test procedure can be used diagnostically to investigate factors that affect hood performance. It is not possible to describe all situations that may occur. The following describes some common causes of (apparent) poor performance and the methods of using the test diagnostically. Because each situation is different, the investigator can extrapolate these methods to investigate other causes of poor performance.

### B2. OPERATIONAL PROBLEMS

**B2.1 Gas Delivery System Leakage.** In the assembly of the ejector system, care is required to ensure that the system is gastight. In spite of reasonable care in assembly and handling, the cylinder or delivery system can develop leaks. These leaks are often discovered when an unacceptable increase in the background level of tracer gas occurs. This elevated background is often observed after the gas is turned off. Consequently, it is often important to observe background levels of tracer gas between tests.

One possible problem is leakage from the tracer gas cylinder. The leaks can occur most frequently at the regulator. Use the detector as a leak indicator. Move the probe toward the regulator, or along the delivery system, and observe any increase in background level. Even a small leak will have a significant effect on background levels compared to typical acceptance criteria for the tracer gas tests. When a leak is found, testing could continue if the cylinder is placed inside a laboratory hood or the leak is controlled by other ventilation equipment to capture the escaping gas.

In a similar manner, when the ejector is moved between hoods, it can release sufficient tracer gas to preclude completing the next test until the background level has reduced sufficiently. The background level should be observed before zeroing the detector.

**B2.2 Reentry.** Occasionally, tracer gas released inside the hood and discharged through the exhaust system enters the supply system through the outdoor air intake. Reentry results in a slow increase in tracer gas levels, which continue to rise or possibly fall very slowly after the tracer gas block valve is closed. Although reentry is undesirable, it is usually not a fault of the laboratory hood.

To verify the existence of reentry, close the hood sash and relocate the detector probe at a supply fixture. If the

tracer gas levels increase after opening the block valve, reentry is a likely cause of the increased tracer gas levels. Further testing of the hood needs to recognize the potential of reentry.

**B2.3 Duct Leakage.** Some ventilation systems have a positive-pressure exhaust duct. Tracer gas can leak out of the duct and raise background levels. The symptoms are similar to delivery system leakage or reentry.

With the tracer gas flowing through the ejector, trace the duct to determine if it is leaking.

### B3. ROOM CONDITIONS THAT AFFECT HOOD PERFORMANCE

**B3.1 Velocity Effects from Room Air Fixtures.** Room air currents near a laboratory hood, referred to as *cross-drafts* or *crosscurrents*, can be detrimental to laboratory hood performance. The source of cross-drafts can be supply air diffusers, exhaust air grilles, adjacent laboratory doors, people walking in front of the hood, and equipment (including cooling fans). Although many published papers describe the problem of cross-drafts, only anecdotal evidence provides general guidance. The usual recommendations are to have the room air currents near the hood less than half, and sometimes less than one-third, of the face velocity.

When hood performance is less than desired, investigation of the room air currents is warranted. The least complex approach is to release smoke around the hood and observe the direction and velocity of the air. Significant problems are easily observable. However, when the room air currents are subtle or fluctuating, smoke may not be conclusive. In addition, the subjective nature of the smoke visualization observations may lead to controversy.

The face velocity measurement techniques of this standard can be modified to measure room air currents. Because the anemometer measures the speed of the air and not the direction, there is often a significant variation in measuring room air currents. If the anemometer is nondirectional, it provides the magnitude of the airflow, and smoke visualization or other methods are used to determine the direction of the airflow. If the probe is directional (not a problem for face velocity since it is assumed the airflow is perpendicular to the face of the hood), orientation of the probe is critical. Often the probe orientation changes to measure the flow perpendicular to the face of the hood, parallel to the face, or in the vertical direction. Even with three measurements, the direction may require smoke visualization (the anemometer does not distinguish between right-to-left movement and left-to-right movement).

Establish a sampling grid exterior to the hood opening that consists of a 3 × 3 ft (1 × 1 m) array. The measurement array should be 1.5 ft (0.5 m) in front of the plane of the sash with measurement points at the left, center, and right locations and the top, middle, and bottom of the maximum sash opening area as depicted in Figure B.1. If the fume hood is adjacent to a wall, then the measurement should be 6 in. (150 mm) from the wall. Both the direction and magnitude of the cross-draft velocities are important to characterizing room air patterns. Perform the following steps to check the velocity effects from air fixtures in the room:

### Cross Draft Grid & Probe Orientation

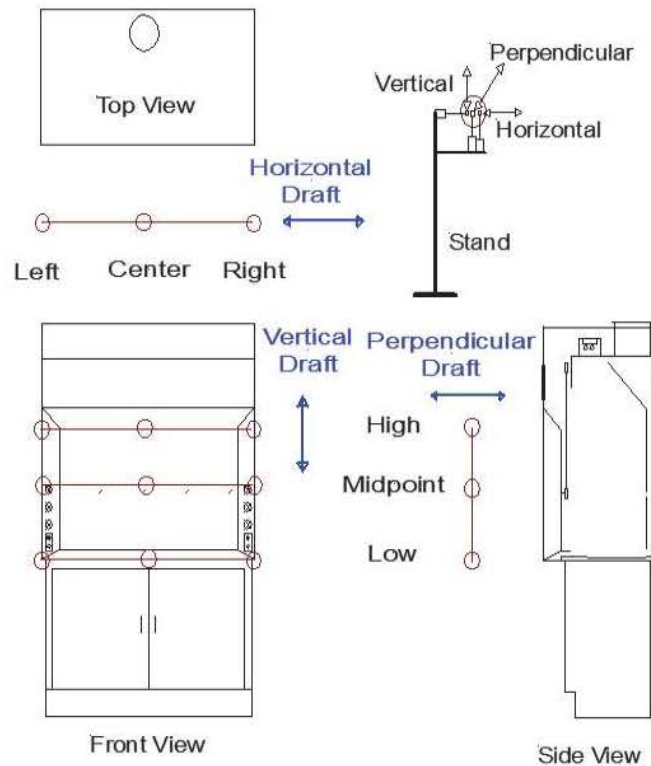

**FIGURE B.1 Cross-draft measurement locations.**

- Close the sash on constant-volume hood systems or open the sash to the design operating height for VAV hood systems.
- Measure the room air currents using a thermal anemometer capable of measuring air velocities over a range of 20 to 200 fpm (0.1 to 1.0 m/s).
- Locate the probe on an adjustable stand at each of the grid locations and measure the vertical, horizontal, and perpendicular cross-draft velocities at each point.
- Using a data logger, record the velocities at a rate of one reading per second for 20 seconds. The best results occur when three anemometers are used to collect the data simultaneously.
- Analyze the data and report the average and maximum room air currents at each location.
- In some cases, smoke visualization can suggest optimum locations for room air current measurements.

**B3.2 Smoke Visualization.** This standard includes smoke visualization tests. In many cases, the use of smoke visualization can explain poor performance in the hood. Lazy flow or reverse flow, even when smoke does not escape from the hood, could show points of weakness or instability at the hood. Turbulence at the bottom edge of the sash or at the header panel may be associated with loss of tracer gas containment.

Smoke visualization with the mannequin located at a test position may show significantly different airflow patterns than that observed without the mannequin. **Note:** When test-

ing with the mannequin, remove the tracer gas detector because the smoke can damage it.

The large smoke system can be used to simulate an ejector. The smoke indicates the airflow patterns of the tracer gas. However, the dynamics of the gas and the smoke are different because the momentum and volume of the release are different. In addition, the smoke dissipates rapidly compared to the tracer gas.

In "as used" (AU) tests, smoke can demonstrate the effect of obstruction to airflow.

(Clearance Time) The clearance time for a hood is defined as the length of time for smoke, released in the upper cavity of the hood with a large smoke challenge, to dissipate so that it no longer is visible. The test is conducted by releasing smoke within the roll for at least 30 seconds, then withdrawing the source. The clearance time is the time it takes for the smoke to dissipate sufficiently that it can no longer be seen.

**B3.3 Exhaust Flow Stability Test.** The stability of exhaust flow can be critical to fume hood containment and is applicable to both constant-volume and VAV hood systems. The following exhaust flow stability test is intended to evaluate the stability of flow under static sash conditions. The exhaust flow stability test uses the same setup as described in the VAV flow response test.

- Open the sashes to design opening area.
- Record flow or slot velocity at a rate of one reading per second using a data logger for five minutes.

- c. Calculate the average, standard deviation, maximum, and minimum of the readings.
- d. Analyze the flow stability:
  - 1. Determine the coefficient of variation (COV) determined from the following equation:

$$\text{COV}\% = 3 \times \text{standard deviation/average}$$

- 2. Determine the relative range:

$$\text{Relative range} = (\text{maximum} - \text{minimum})/\text{average}$$

**B3.4 Heat Effects in the Hood.** Hot equipment such as hot plates and gas burners used in laboratory hoods produce thermal currents that may affect hood performance. Several members of the project committee that developed this standard have conducted preliminary tests. They used hot plates to simulate heat generated within a laboratory hood. The tests used one or two hot plates with a rating up to 5000 Btu/h (1500 W). The preliminary results raised concerns about the effect of higher-heat sources. However, the preliminary data support the following statement.

When moderate individual heat sources producing less than 100 to 150 W/ft<sup>2</sup> (10 to 15 W/m<sup>2</sup>), for example, hot plates or gas burners, are placed in a fume hood, they do not appear to have a significant effect on hood performance. Hoods designated to handle heat sources releasing more than 150 W/ft<sup>2</sup> (15 W/m<sup>2</sup>) should be tested under loaded conditions.

**B3.5 Laboratory Hood Ceiling Enclosures.** In laboratories with lay-in ceiling panels, an architectural skirt is often added to the top of the hood. This skirt may extend into the lay-in ceiling. The pressure (positive or negative) in the plenum above the lay-in ceiling can affect hood performance, especially if there are fluctuations in the pressure. If the plenum space is positive, air can flow into the hood through the bypass or between the sash and the hood structure, reducing the effective face velocity. If the plenum space is negative, potentially contaminated air can flow from the hood into the plenum space.

Releasing smoke between the sash and the header panel can show this airflow. However, if the flow is very slow, using smoke may not be sufficient. Tracer gas can be used to demonstrate whether contamination from inside the hood migrates into the ceiling plenum. The impact of the plenum on the hood enclosure is tested as follows:

- a. Determine possible paths for the airflow into or out of the hood.
- b. Place the probe in these areas.
- c. Turn on the detector.
- d. Release tracer gas into the hood.
- e. Record tracer gas concentrations for 2 minutes to determine if any leakage is occurring. If non-zero readings are observed, calculate maximum and average concentrations.

**B3.6 Equipment in the Hood.** The exposure of the worker at a laboratory hood is dependent on a multitude of factors, including the size, location, and energy (thermal or mechanical) of the equipment inside the hood. To obtain an accurate indication of these factors on hood containment, an “as used”

(AU) test should be run with the actual equipment set up and functional. An alternative would be to mock up equipment of the approximate physical size and location.

To improve airflow at the face of the hood, any large apparatus should be located as far back as possible in the hood (a minimum of 6 in. [150 mm] behind the sash). In addition, placing the apparatus on a 1 to 2 in. (25 to 55 mm) stand to allow the air to pass under the equipment has been beneficial. Finally, heat-generating equipment inside the hood creates an additional challenge.

Smoke visualization and tracer gas testing, in an “as-used” (AU) test, can be used to determine the effect of equipment or heat sources inside the hood. Any arbitrary hood load test that is representative of the actual usage may be used as an indication of the effect on containment.

**B3.7 Side-by-Side Laboratory Hood Installations.** Often laboratory hoods are installed adjacent to each other. If the face velocity is higher for one hood, the airflow can affect the flow patterns on the adjacent hood. In extreme cases, the disturbing flow can affect the hood performance of the hood with lower face velocity. This condition can be investigated by smoke visualization methods or by adjusting the face velocities and then retesting.

**B3.8 Fan Leakage.** All centrifugal exhaust fans leak.<sup>B-1, B-2</sup> The leakage occurs at the shaft penetration to the fan housing, at the connection between the fan and the exhaust duct or stack, and in positively pressurized exhaust duct. Most often, the leakage affects maintenance personnel; however, when a fan is located in the laboratory or the laboratory is negative in pressure relative to the fan room, the leakage could cause exposures to laboratory personnel. When this leakage and migration of tracer gas occurs, it can affect tracer gas measurements.

The methods described in the standard can be used to evaluate fan rooms and explore leakage of positive-pressure ducts in the laboratory. Tracer gas is released in a laboratory hood, and the detector monitors the concentration of tracer gas in the fan room along the positive-pressure ducts or at the penetration to the laboratory.

**B3.9 VAV Airflow Control Devices.** While the majority of laboratory hoods are installed on constant-volume systems, a growing number of laboratories use VAV supply and exhaust systems. These VAV systems can reduce the volume of air exhausted from the laboratory. It is important to ensure that the VAV systems are properly designed, calibrated, and maintained. The VAV systems, just like all other components of the HVAC system, must function correctly to ensure that fume hood performance is not compromised.

If the VAV airflow control device is suspected of contributing to the poor performance of the laboratory hood, several issues can be investigated.

It is important to ensure that the VAV airflow control device is performing properly and in accordance with the manufacturer’s specifications and requirements. The VAV airflow control device should open and close in response to a control signal from a sensor on the laboratory hood, regulating the exhaust flow to maintain a constant face velocity. If the airflow control device does not react sufficiently fast, the

face velocity may not stabilize quickly enough to provide adequate containment. Reasons for a slow response time include inadequate calibration of the controller, sensor, or airflow control device, or that the airflow control device is located too far from the laboratory hood. Section 7.3 describes a test procedure to determine the response time and the stability of VAV controllers. If containment is not adequate when the sash is opened, the speed of response should be investigated as a cause.

Many VAV systems reduce the capital cost of the exhaust and supply system by using a diversity factor. The total capacity of the system, or of a specific segment of the system, is determined by assuming that some of the hoods are operating with the sash closed. When the sash is closed, the volumetric flow is determined by safety considerations rather than face velocity.<sup>B-3, B-4</sup> If more hoods are required to operate than the capacity of the system can meet the demand for, the hood face velocity can be well below the design conditions. This can result in poor fume hood performance.

**B3.10 Sash Opening.** Some designs specify the maximum allowable sash height. Often building ventilation systems provide sufficient face velocity through the reduced opening. Once the laboratory hood sash is opened beyond the design opening, hood performance may degrade. Strict administrative controls are required when a system is designed and operated with diversity or sash limits.

Because operators often open the sash above the sash stop, tests should be conducted with the sash full open.

## **B4. OTHER CONSIDERATIONS**

**B4.1 Walk-By Tests.** Walk-by tests often show the effect caused by the wake of a person walking by the hood. Place a source of smoke inside the hood and observe the effect as people walk by the hood. Although the test is merely informative, it can show that several variables have a significant effect on the results. These variables include the speed of the walker, the distance to the hood, the size and shape of the walker, the face velocity, and the sash configuration. Because the eddy formed as a person walks past the hood is often higher than the face velocity, the effect of an aggressive walk-by can be aspiration of the hood. The test results can often be used as training information to ensure good work practices in the laboratory.

**B4.2 Mechanical Walk-By Tests.** To eliminate or control some of the variables associated with a walk-by test, the test can be automated. The automated mannequin walk-by test is set up in the same manner as a standard tracer gas test, except

that behind the mannequin at the hood, a second mannequin is placed on a rail system. The second mannequin performs constant-speed walk-by challenges in which the mannequin moves back and forth at a fixed geometry and a fixed speed.

The walk-by mannequin's near shoulder is placed 24 in. (610 mm) off the plane of the laboratory hood sash. The walk-by speed is at a rate of 3 ft/s (0.91 m/s). In one test, the walk-by produced measured cross-drafts averaging 26 fpm (0.13 m/s) with peaks as high as 34 fpm (0.17 m/s). These measurements were taken perpendicular to the hood face between the walk-by mannequin and the hood face at both waist and shoulder heights at various points across the face of the hood. The walk-by mannequin does not simulate arm or leg movement.

### **B4.3 Viability of Tracer Gas as a Surrogate for Particles.**

Many laboratory hoods are used in applications where the contaminant of concern is particulate (dust, mist, or fume) rather than a gas or vapor. Since the particulate of concern is often very small (less than 50 micrometers in aerodynamic diameter), the particles have low settling velocities and tend to follow the air streamlines. In limited testing, the performance of an exhaust hood appears to be similar whether the contaminant is a tracer gas or a particulate. However, particulate spills, dribble, and carryout of dust can significantly affect the test results. Because the testing requires laboratory analysis, exterior room contamination is more difficult to determine until the tests are completed, whereas with tracer gas and a continuous monitor, the increase in background levels can be observed during the tests. Although the preliminary (and unpublished) results are interesting, additional investigation is warranted.

## **B5. APPENDIX B REFERENCES**

- B-1 American Industrial Hygiene Association, ANSI/AIHA Z 9.5-2003, American National Standard Laboratory Ventilation, Fairfax, VA, 2003.
- B-2 Hitchings, Dale, "Laboratory fume hood and exhaust fan penthouse exposure risk analysis using the ANSI/ASHRAE 110-1995 and other tracer gas methods," *ASHRAE Transactions* 103(2), 1997.
- B-3 Knutson, G.W., "Potential exposure to airborne contamination in fan penthouses," *ASHRAE Transactions* 103(2), 1997.
- B-4 National Fire Protection Association, NFPA 45-2004, *Standard on Fire Protection for Laboratories Using Chemicals*, Quincy, MA, 2004.

**(This appendix is not part of this standard. It is merely informative and does not contain requirements necessary for conformance to the standard. It has not been processed according to the ANSI requirements for a standard and may contain material that has not been subject to public review or a consensus process. Unresolved objectors on informative material are not offered the right to appeal at ASHRAE or ANSI.)**

## **INFORMATIVE APPENDIX C EXAMPLE REPORT**

The results of hood performance testing can be communicated in many ways. The following outline includes major points that are often incorporated into a report describing performance testing using this standard. The outline is only a suggestion to ensure completeness of the report.

- a. Design criteria (defined by the owner, hood specifications, or test documents)
  1. Sash design position or positions
  2. Average face velocity
  3. Acceptable range of face velocities
  4. Average face velocity for sash at 25% and 50% of the design hood opening
  5. Performance rating
  6. Sash movement effect performance rating
  7. For VAV hoods:
    - i. VAV speed of response time
    - ii. VAV time to steady state
  8. For auxiliary air hoods only: the percentage of auxiliary air supply
- b. General
  1. Test site, owner, reason for testing
  2. Investigator, date, project number or identifier
- c. Hood information
  1. Hood type, including sash type
  2. Hood manufacturer and model
  3. Location (room number) and identification (hood number)
- d. System information
  1. Exhaust system description
  2. Supply air description
- e. Laboratory configuration
  1. Hood location
  2. Supply and exhaust systems
  3. Room activity
- f. Test equipment
  4. Room sketch or reference to drawings
  1. Velocity probes
  2. Smoke visualization methods (local and large-volume smoke generation)
  3. Tracer gas detector
  4. Mannequin
- g. Calibration (methods, frequency, and results)
  1. Detector
  2. Ejector
  3. Velocity instruments
- h. Test conditions
  1. Sash opening heights depths
  2. Clutter in hood
  3. Baffle position (slot size)
  4. Background (zero) testing
- i. Hood monitor
  1. Type
  2. Reading
- j. Test results
  1. Face velocity readings
    - i. Grid description
    - ii. Average face velocity
    - iii. High and low grid readings
    - iv. Face velocity control tests (for VAV systems)
    - v. VAV response tests
      - I. VAV speed of response
      - II. VAV time to steady state
  2. Smoke observation
    - i. Description of methods
    - ii. Observation
      - I. Local visualization challenge
      - II. Large-volume visualization challenge
  3. Tracer gas results
  4. Sash movement effects
  5. Peripheral scan
- k. Factors affecting hood performance (if an explanation of results is indicated)
  1. Cross-drafts
  2. Activities in the room
  3. Thermal effects
- l. Conclusions
  1. Comparison to design criteria
  2. Recommendations
  3. Future testing

**(This appendix is not part of this standard. It is merely informative and does not contain requirements necessary for conformance to the standard. It has not been processed according to the ANSI requirements for a standard and may contain material that has not been subject to public review or a consensus process. Unresolved objectors on informative material are not offered the right to appeal at ASHRAE or ANSI.)**

## **INFORMATIVE APPENDIX D BIBLIOGRAPHY**

- ASHRAE. 2007. Chapter 14, Laboratories, in *ASHRAE handbook—HVAC applications*. Atlanta: ASHRAE.
- Adams, John B., Jr. 1989. Synthesis—Laboratory fume hoods: Easy, reliable performance evaluation and importance of sash design. *Journal of Chemical Education* 66(12):A389–A291.
- ANSI/AIHA Z9.5-2003, Laboratory Ventilation.
- Caplan, K.J., and G.W. Knutson. 1977. The effect of room air challenge on the efficiency of laboratory fume hoods. *ASHRAE Transactions* 83(1):141–56.
- Caplan, K.J., and G.W. Knutson. 1978. Laboratory fume hoods: influence of room air supply. *ASHRAE Transactions* 84(1):552–37.
- Caplan, K.J., and G.W. Knutson. 1978. Laboratory fume hoods: A performance test. *ASHRAE Transactions* 84(1):511–21.



## **POLICY STATEMENT DEFINING ASHRAE'S CONCERN FOR THE ENVIRONMENTAL IMPACT OF ITS ACTIVITIES**

ASHRAE is concerned with the impact of its members' activities on both the indoor and outdoor environment. ASHRAE's members will strive to minimize any possible deleterious effect on the indoor and outdoor environment of the systems and components in their responsibility while maximizing the beneficial effects these systems provide, consistent with accepted Standards and the practical state of the art.

ASHRAE's short-range goal is to ensure that the systems and components within its scope do not impact the indoor and outdoor environment to a greater extent than specified by the Standards and Guidelines as established by itself and other responsible bodies.

As an ongoing goal, ASHRAE will, through its Standards Committee and extensive Technical Committee structure, continue to generate up-to-date Standards and Guidelines where appropriate and adopt, recommend, and promote those new and revised Standards developed by other responsible organizations.

Through its *Handbook*, appropriate chapters will contain up-to-date Standards and design considerations as the material is systematically revised.

ASHRAE will take the lead with respect to dissemination of environmental information of its primary interest and will seek out and disseminate information from other responsible organizations that is pertinent, as guides to updating Standards and Guidelines.

The effects of the design and selection of equipment and systems will be considered within the scope of the system's intended use and expected misuse. The disposal of hazardous materials, if any, will also be considered.

ASHRAE's primary concern for environmental impact will be at the site where equipment within ASHRAE's scope operates. However, energy source selection and the possible environmental impact due to the energy source and energy transportation will be considered where possible. Recommendations concerning energy source selection should be made by its members.

**About ASHRAE**

ASHRAE, founded in 1894, is a global society advancing human well-being through sustainable technology for the built environment. The Society and its members focus on building systems, energy efficiency, indoor air quality, refrigeration, and sustainability. Through research, Standards writing, publishing, certification and continuing education, ASHRAE shapes tomorrow's built environment today.

For more information or to become a member of ASHRAE, visit [www.ashrae.org](http://www.ashrae.org).

To stay current with this and other ASHRAE Standards and Guidelines, visit [www.ashrae.org/standards](http://www.ashrae.org/standards).

**Visit the ASHRAE Bookstore**

ASHRAE offers its Standards and Guidelines in print, as immediately downloadable PDFs, on CD-ROM, and via ASHRAE Digital Collections, which provides online access with automatic updates as well as historical versions of publications. Selected Standards and Guidelines are also offered in redline versions that indicate the changes made between the active Standard or Guideline and its previous version. For more information, visit the Standards and Guidelines section of the ASHRAE Bookstore at [www.ashrae.org/bookstore](http://www.ashrae.org/bookstore).

**IMPORTANT NOTICES ABOUT THIS STANDARD**

**To ensure that you have all of the approved addenda, errata, and interpretations for this Standard, visit [www.ashrae.org/standards](http://www.ashrae.org/standards) to download them free of charge.**

**Addenda, errata, and interpretations for ASHRAE Standards and Guidelines are no longer distributed with copies of the Standards and Guidelines. ASHRAE provides these addenda, errata, and interpretations only in electronic form to promote more sustainable use of resources.**