



# Standard Guide for Selection of Structural Details for Ship Construction<sup>1</sup>

This standard is issued under the fixed designation F 1455; the number immediately following the designation indicates the year of original adoption or, in the case of revision, the year of last revision. A number in parentheses indicates the year of last reapproval. A superscript epsilon ( $\epsilon$ ) indicates an editorial change since the last revision or reapproval.

## INTRODUCTION

The principal aim of this guide is to depict recommended practices related to the design of ship structural details. The importance of structural details is clear:

- 1) Their layout and fabrication represent a sizable fraction of hull construction costs.
- 2) Details are often the source of cracks and other failures which, under certain circumstances, could lead to serious damage to the ship hull girder.
- 3) The trend toward decreasing ship hull scantlings (that is, increasing average hull stresses) has the potential of increasing the damage to details.
- 4) Researchers have largely neglected the analysis of structural details at least in part because the configuration and purpose of these details vary greatly and are not commonly described or discussed in the literature.

Due to lack of analytical and experimental effort devoted to structural details, their determination has been left up to draftsmen and designers, with very little engineering input.

In two comprehensive reviews<sup>2,3</sup> of the performance of structural details, 86 ships were surveyed. These included naval and commercial ship types. The commercial ships included both U.S. and foreign built. The vessels ranged from 428 to 847 feet in length, from 18,000 to 90,000 tons in displacement, and from five to twenty-six years in age. The details obtained were grouped into 12 typical families. Knife Edge Crossings (Family No. 6) and Structural Deck Cutout Details (Family No. 9) are shown but not covered in detail in this guide. The remaining ten detail families were further categorized into 53 groups comprising a total of 611 detail configurations. A number of these configurations are very similar to others in detail geometry and such duplicates have been excluded from this guide. A number of others were eliminated because of relatively infrequent observed use. As a result, a total of 414 details are included herein. However, all 611 details can be found in "Structural Details,"<sup>4</sup> if desired.

In total, 607,584 details were observed with a total of 6,856 failures. Failures were attributed to one or a combination of five categories: design, fabrication, welding, maintenance, and operation (see 4.1 through 4.5). This extensive, well documented research, together with engineering judgement, provides the principal support for this guide.

## 1. Scope

1.1 This guide provides a recommended list of selected ship structure details for use in ship construction.

1.2 Structural details which have failed in service and are not recommended for use in ship construction are included as well.

1.3 This guide is intended to convey the lessons learned on different configurations of ship structure details, not the dimensions, thickness, or construction methods which would result from structural calculations.<sup>4</sup>

## 2. Terminology

### 2.1 Definitions of Terms Specific to This Standard:

#### 2.1.1 Terms:

2.1.2 *beam bracket*—a bracket at the end of framing or stiffening members that is used for increased strength, continuity and end constraint.

<sup>1</sup> This practice is under the jurisdiction of ASTM Committee F25 on Shipbuilding and is the direct responsibility of Subcommittee F25.01 on Structures. Current edition approved Dec. 15, 1992. Published February, 1993.

<sup>2</sup> Jordan, C. R., and Cochran, C. S., "In-service Performance of Structural Details," SSC-272, *Ship Structure Committee Report*, March 1977, available through the National Technical Information Service, Springfield, VA 22161.

<sup>3</sup> Jordan, C. R., and Knight, L. T., "Further Survey of In-service Performance of Structural Details," SSC-294, *Ship Structure Committee Report*, May 1979, available through the National Technical Information Service, Springfield, VA 22161.

<sup>4</sup> Jordan, C. R., and Krumpfen, P., Jr., "Structural Details," *American Welding Society Welding Journal*, Vol 63, No. 1, January 1984.

2.1.2.1 *Discussion*—see Fig. 1.

2.1.3 *clearance cut-outs*—a hole or opening in a pierced member to allow passage of a piercing member.

2.1.3.1 *Discussion*—see Fig. 2.

2.1.4 *gunwale connection*—the connection of the sheer strake to the stringer strake of the uppermost deck of the hull.

2.1.4.1 *Discussion*—see Fig. 3.

2.1.5 *knife edge crossing*—the projected point intersection of members (plate members, stiffeners or bulkheads) on opposite sides of an intervening plate member. An undesirable condition to be avoided.

2.1.5.1 *Discussion*—Included for information only, see 3.1.

2.1.5.2 *Discussion*—see Fig. 4.

2.1.6 *miscellaneous cut-out*—small holes or openings of a variety of sizes and shapes used for access, drainage, ease of fabrication, stress relief, and so forth.

2.1.6.1 *Discussion*—see Fig. 5.

2.1.7 *non-tight collar*—a fitting at the cut-outs in way of the intersection of two continuous members that provides lateral support for the piercing member which does not fully fill the cut-out area of the pierced member. May be a lug.

2.1.7.1 *Discussion*—see Fig. 6.

2.1.8 *panel stiffeners*—intercostal, non-load-carrying members used to reduce the size of plate panels.

2.1.8.1 *Discussion*—see Fig. 7.

2.1.9 *stanchion ends*—structural fittings at the ends (top and bottom) of a stanchion to transfer loads from the supported member to the supporting member.

2.1.9.1 *Discussion*—see Fig. 8.

2.1.10 *stiffener ends*—the configuration of the end of an unbracketed, non-continuous stiffener.

2.1.10.1 *Discussion*—see Fig. 9.

2.1.11 *structural deck cuts*—allow passage through decks for access, tank cleaning, piping, cable, and so forth.

2.1.11.1 *Discussion*—Included for information only, see 3.1.

2.1.11.2 *Discussion*—see Fig. 10.

2.1.12 *tight collar*—as per non-tight collar but the cut-out in the pierced member is fully filled and is air-, oil-, or watertight as required. Tight collars may be lapped or flush fitted.

2.1.12.1 *Discussion*—see Fig. 11.

2.1.13 *tripping bracket*—a bracket or chock that provides lateral support to framing and stiffening members. Support may be provided to either the web or the flange, or to both.

2.1.13.1 *Discussion*—see Fig. 12.

2.2 *Symbols: Symbols:*

2.2.1 Symbols are as indicated in Fig. 13. The detail identification symbol (Fig. 13, 1-J-1 for example) is the same

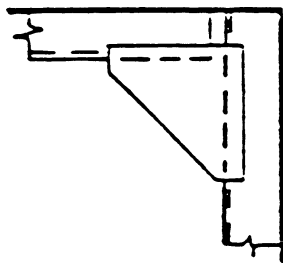

FIG. 1 Beam Brackets (Family No. 1)

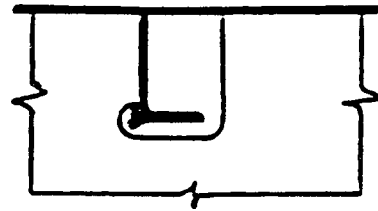

FIG. 2 Clearance Cut-outs (Family No. 8)

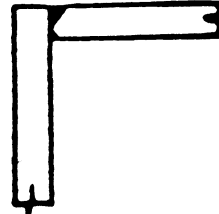

FIG. 3 Gunwale Connections (Family No. 5)

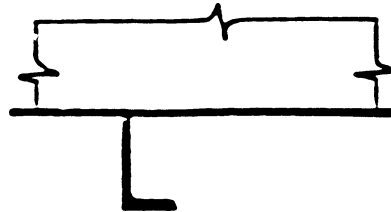

FIG. 4 Knife Edge Crossing (Family No. 6)

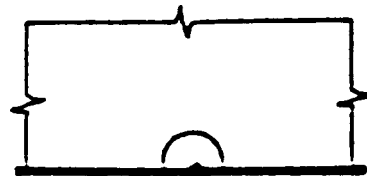

FIG. 5 Miscellaneous Cut-outs (Family No. 7)

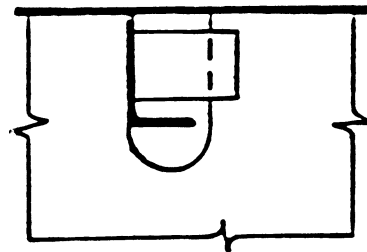

FIG. 6 Non-Tight Collars (Family No. 3)

as that assigned in the original research reports and is retained throughout for all details for ease in referring back to the reports if desired.

3. Summary of Guide

3.1 In this guide, details are shown for the ten families of structural details identified above and as shown in Fig. 1–3, 5–9, 11 and 12. Knife Edge Crossings, Fig. 4, are not discussed further in this guide since none were observed in the research and fortunately so. This detail represents very undesirable structural conditions and is to be avoided. Structural Deck Cuts, Fig. 10, are not discussed in this guide since this detail

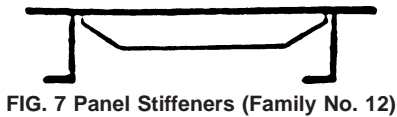

FIG. 7 Panel Stiffeners (Family No. 12)

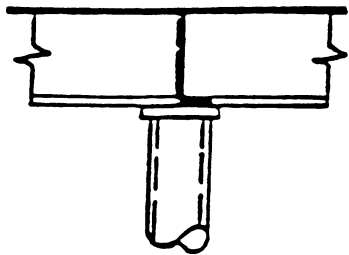

FIG. 8 Stanchion Ends (Family No. 10)

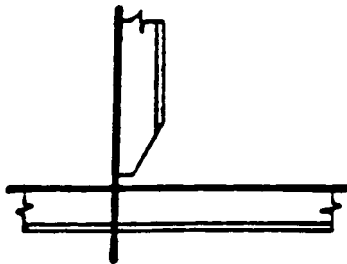

FIG. 9 Stiffener Ends (Family No. 11)

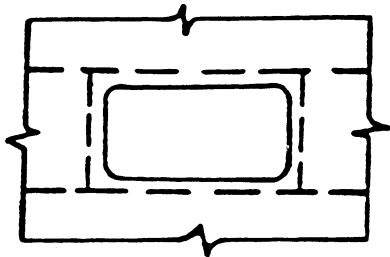

FIG. 10 Structural Deck Cuts (Family No. 9)

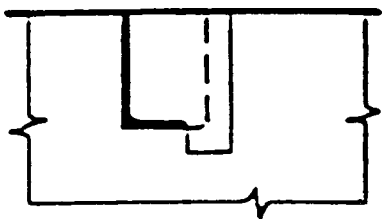

FIG. 11 Tight Collars (Family No. 4)

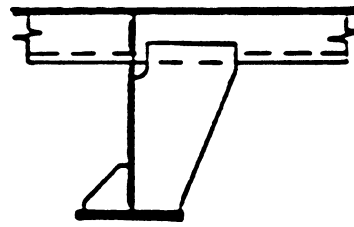

FIG. 12 Tripping Brackets (Family No. 2)

failures within each family group are shown in descending order of numbers observed. Those details with failures are shown in ascending order of failures (percentage are indicated for each). Thus the first detail shown in each family group has the best observed service performance and is most highly recommended while the last has the highest failure rate and therefore least desirable.

3.3 These details, rated as indicated above, provide guidance in the selection of structural detail configurations in future design and repair of such details.

#### 4. Failure Causes

4.1 Failures in the details shown in Figs. 14-28 were attributed to either one or a combination of five categories: design, fabrication, welding, maintenance, and operation.

##### 4.1.1 Design:

4.1.1.1 Design failures generally resulted from the omission of engineering principles and resulted in a buckled plate or flange; the formation of a crack in a plate, flange or web; or the rupture of the bulkhead, deck or shell. Each of the families, with the exception of tight collars, had detail failures attributed to design.

4.1.1.2 Failures directly related to design in structural details and supporting members were the result of being sized without adequate consideration of applied forces and resulting deflections.

4.1.1.3 In the beam bracket configurations of family no. 1 (Fig. 14), 20 % of the surveyed failures attributed to design were caused by instability of the plate bracket edge or by instability of the plate bracket panel. This elastic instability, which resulted from loads that produce critical compressive or shear stresses, or both, in unsupported panels of plating, can be eliminated when properly considered in the design process.

4.1.1.4 The failures of beam brackets by cracking occurred predominately where face plates had been sniped, at the welded connections, at the ends of the brackets, at cutouts in the brackets, and where the brackets were not properly backed up at hatch ends. The sniping of face plates on brackets prevents good transition of stress flow, creates hard spots and produces fatigue cracks due to the normally cyclic stresses of these members. Care must be taken to ensure proper transition with the addition of chocks, back-up structure, reinforcement of hole cuts, and the elimination of notches.

4.1.1.5 To reduce the potential for lamellar tearings and fatigue cracks in decks, bulkheads, and beams, transition brackets should be made continuous through the plating or supported by stiffeners rigid enough to transmit the loads.

4.1.1.6 The greater number of failures in the tripping bracket configurations of family no. 2 (Fig. 18), occurred at

must be considered in relation to the size of the opening and its proximity to primary structures.

3.2 Evaluation of details shown in Figs. 14-28 is based on in-service experience as described in "Design Guide for Structural Details".<sup>5</sup> Data for over 400 details is summarized and rated in the figures by observed relative successful performance. Each of the ten families of details include configurations with no signs of failures. The details without

<sup>5</sup> Jordan, C. R., and Krumpin, R. P., Jr., "Design Guide for Structural Details," SSC 331, *Ship Structure Committee Report*, August 1990, available through the National Technical Information Service, Springfield, VA 22161.

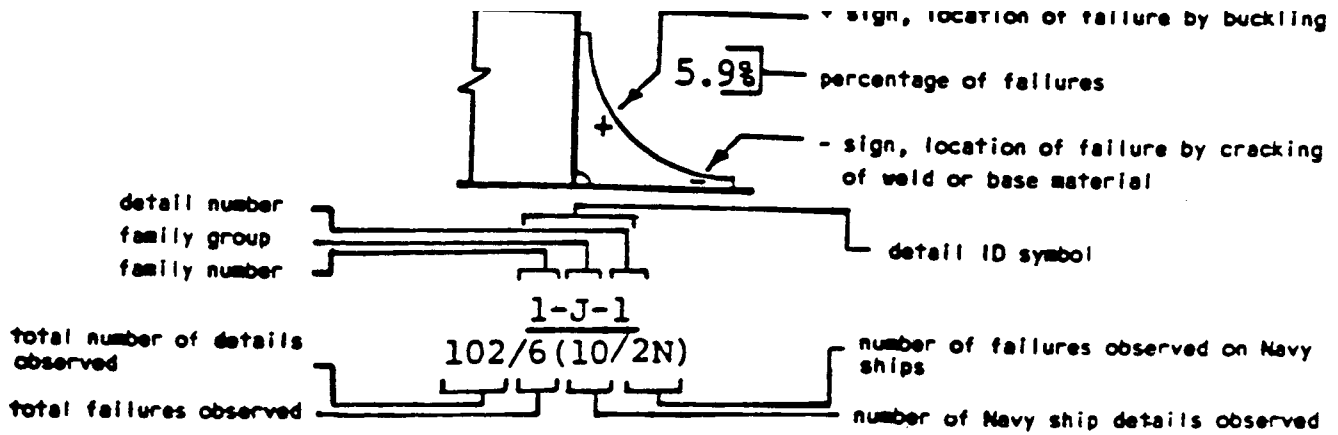

FIG. 13 Symbols

hatch side girders, particularly in containerships. This will be a continuing problem unless the brackets are designed to carry the large lateral loads due to rolling when containers are stacked two to four high on the hatches. The brackets must, in turn, be supported by properly designed backing structure to transmit the loads to the basic ship structure.

4.1.1.7 Tripping brackets supported by panels of plating can be potential problems depending on the plate thickness. Brackets landing on thick plating in relationship to its own thickness may either buckle in the panel of the bracket, produce fatigue cracks along the toe of the weld, or cause lamellar tearing in the supporting plate. Brackets landing on plating with a thickness equal to, or less than its own thickness, may cause either fatigue cracks to develop or buckling of an unsupported panel of plating.

4.1.1.8 The non-tight collar configurations of family no. 3 (Fig. 21) experienced only a few failures. There are considerations, however, that must be used by the designer to ensure the continuation of this trend. The cutouts should be provided with smooth well rounded radii to reduce stress risers. Where collars are cut in high stress areas, suitable replacement material should be provided to eliminate the overstressing of the adjacent web plating. These considerations should reduce the incidents of plate buckling, fatigue cracking, and stress corrosion observed in this family.

4.1.1.9 For detail family no. 7, miscellaneous cutouts, (Fig. 24), the reasons for failure were as varied as the types of cutouts. Potential problems can be eliminated by the designer if, during detail design, proper consideration is given to the following:

- 1) Use generous radii on all cuts.
- 2) Use cuts of sufficient size to provide proper welding clearances.
- 3) Avoid locating holes in high tensile stress areas.
- 4) Avoid square corners and sharp notches.
- 5) Use adequate spacing between cuts.
- 6) Properly reinforce cuts in highly stressed areas.
- 7) Locate cuts on or as near the neutral axis as possible in beam structures.
- 8) Avoid cuts at the head or heel of a stanchion.
- 9) Plug or reinforce structural erection cuts when located in highly stressed areas.

4.1.1.10 The most damaging crack observed during the survey was in the upper box girder of a containership. This structure is part of the longitudinal strength structure of the ship in addition to being subjected to high local stresses due to the container loading in the upper deck. Openings in this structure must be located, reinforced, and analyzed for secondary bending stresses caused by high shear loads.

4.1.1.11 The clearance cutouts of family no. 8 (Fig. 20) are basically non-tight collars without the addition of the collar plate. Suggestions made for non-tight collars and miscellaneous cutouts are applicable for this family.

4.1.1.12 Well rounded corners with radii equivalent to 25 % of the width perpendicular to the primary stress flows should be used. Special reinforcements in the form of tougher or higher strength steel, inserts, coamings, and combinations of the above should be used where fatigue and high stresses are a problem.

4.1.1.13 In general, failures in stanchion ends, family no. 10 (Fig. 25 Fig. 26), were cracks which developed in or at the connection to the attachment structure. The addition of tension brackets, shear chocks, and the elimination of snipes would reduce the incidents of structural failure. All stanchion end connections should be capable of carrying the full load of the stanchion in tension or compression. Stanchions used for container stands or to support such structure as deckhouses on the upper deck should be attached to the deck with long tapered chocks to reduce stress flows from hull induced loads, and in no case should "V" notches be designed into such connections.

4.1.1.14 The stiffener ends in family no. 11 (Fig. 27) with webs or flanges sniped, or a combination of both, or square cut ends sustained failures. In nearly all cases, the failures occurred in the attached bulkhead plating, the web connection when the flange was sniped, or the shear clip used for square cut stiffener ends.

4.1.1.15 Stiffeners that support bulkheads subject to wave slap, such as exposed bulkheads on upper deck, or tank bulkheads, should not be sniped and suitable backing structure should be provided to transmit the end reaction of the stiffeners.

4.1.1.16 While sniping stiffeners ensures easier fabrication, any stiffeners subject to tank pressures or impact type loading

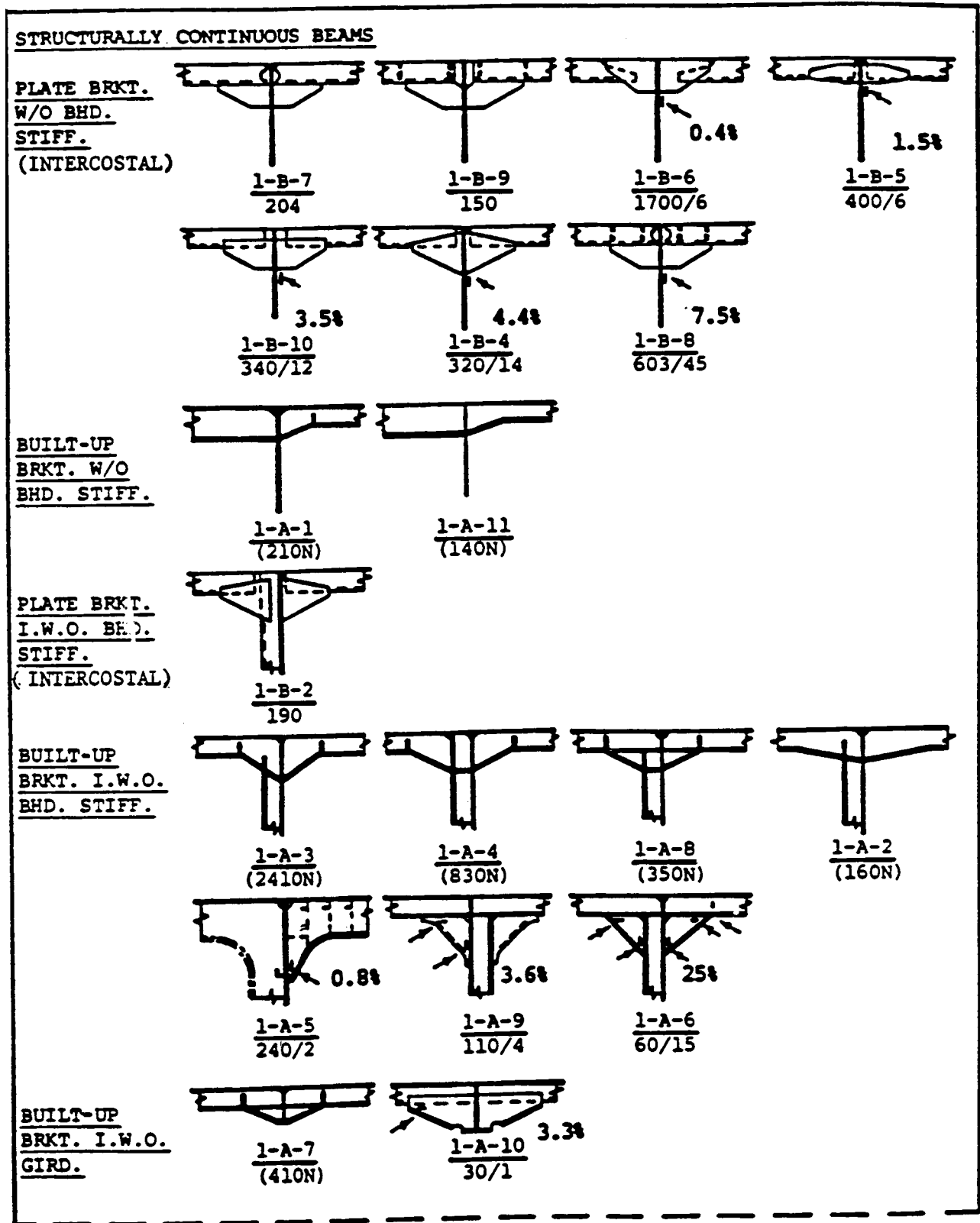

FIG. 14 Performance of Beam Bracket Details (Family No. 1)

should be restrained at the ends and checked for flange stability to prevent lateral instability under load.

4.1.1.17 Panel stiffeners, family no. 12 (Fig. 28) while classified as not being direct load carrying members, should be

designed for the anticipated service load. For instance, panel stiffeners on tank bulkheads, as with any other stiffeners subject to pressure head loads, should be treated the same as other local stiffening.

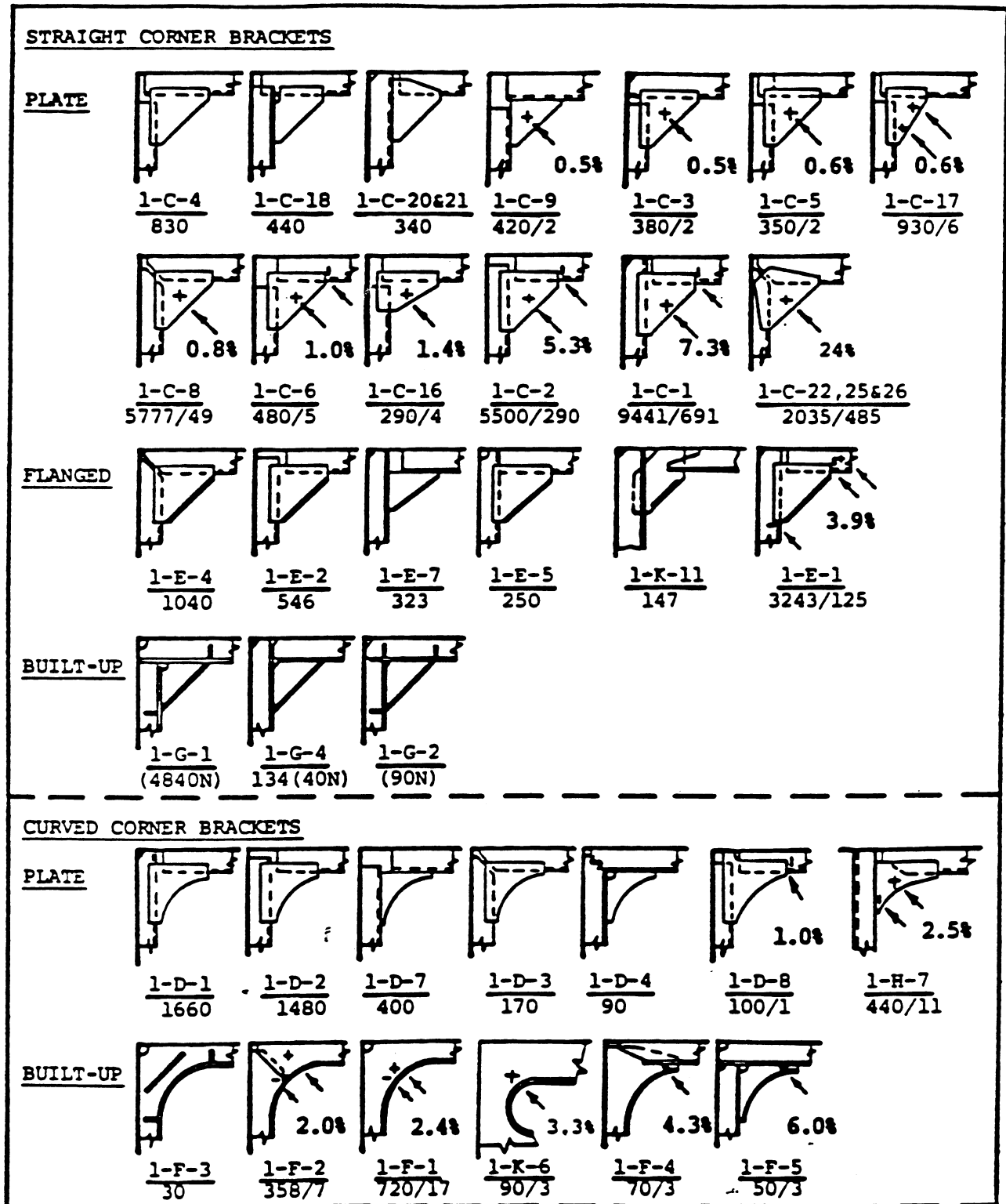

FIG. 15 Performance of Beam Bracket Details (Family No. 1) Cont'd

4.1.1.18 Panel stiffeners used as web stiffeners on deep girders should not be expected to restrain the free flange from buckling in the lateral direction unless they are designed as lateral supports.

4.1.1.19 The design of panel stiffeners should be the same as other local stiffeners with respect to cutouts, notches, and other structural irregularities.

4.1.2 Fabrication:

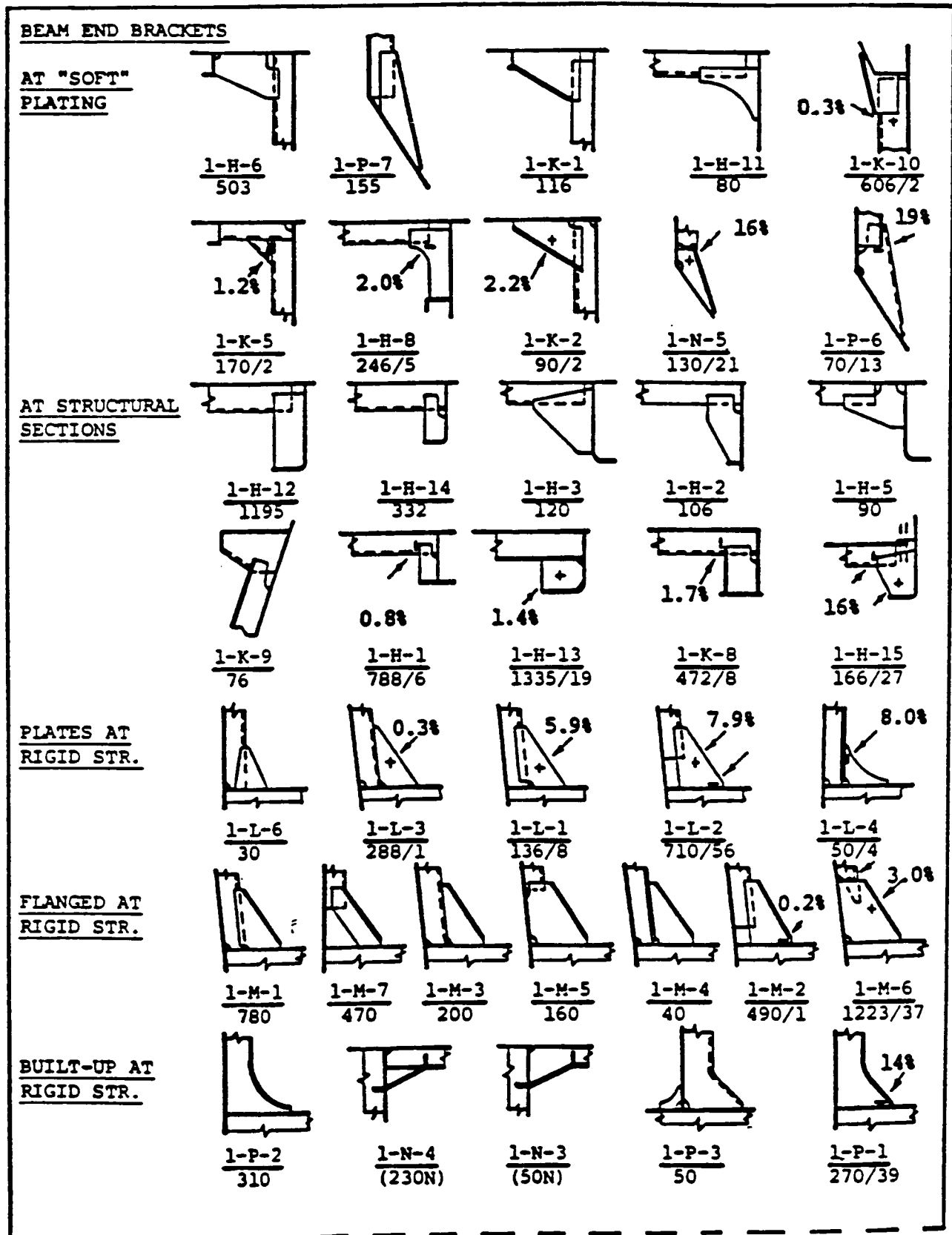

FIG. 16 Performance of Beam Bracket Details (Family No. 1) Cont'd

4.1.2.1 Unexpected stress concentrations produced cracks that initiated from structural cuts, details with poor alignment,

and improperly worked materials. Fabrication techniques that ensure proper continuity of structural parts and eliminate

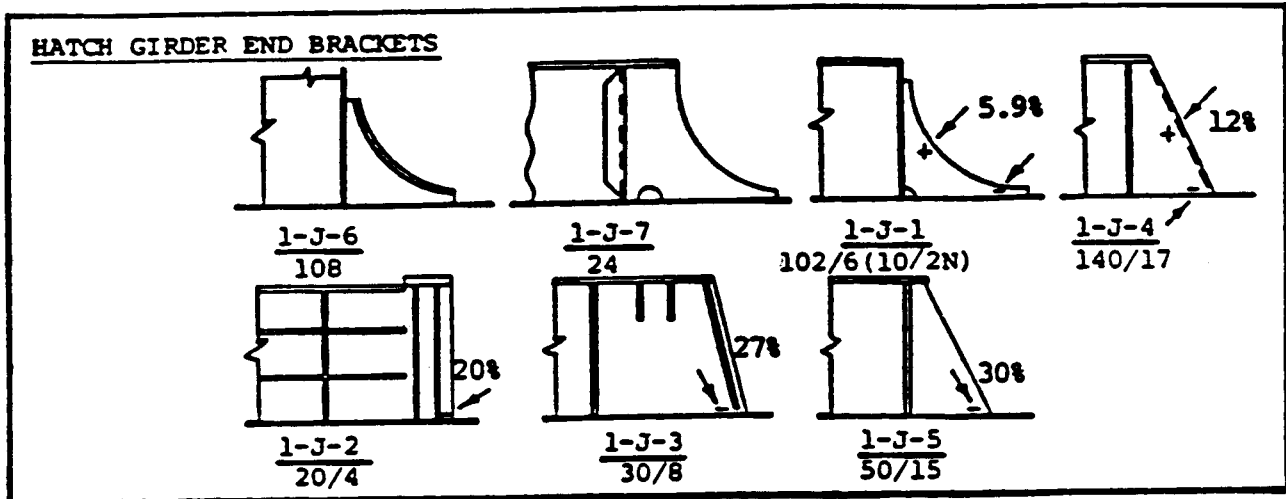

FIG. 17 Performance of Beam Bracket Details (Family No. 1) Cont'd

jagged edges and undercut welds would eliminate such failures. The failures caused by fabrication resulted from:

- 1) Poor cutting techniques (hand cutting or rough cutting with no follow-up dressing).
- 2) Failure to edge prep cutouts and plate edges after flame cutting.
- 3) Improper alignment of intercostal structures.
- 4) High residual stresses due to poor workmanship.

4.1.2.2 The following list should be considered during the fabrication process as an aid to reducing subsequent failures:

- 1) Consult with the designer before deviating from the design details.
- 2) Where hard spots, knife edge crossings, or improper tapers occur, consult with the designer to resolve the problem.
- 3) Avoid misaligned structure.
- 4) Properly dress the edge of all cuts.
- 5) Eliminate notches in any structure whether primary or secondary.
- 6) Only use heat for straightening when approved by design or fabrication documents.
- 7) Only use cold working in areas approved by design or fabrication documents and then only to the minimum extent possible.
- 8) Avoid improper edge distances that must be filled with weld.
- 9) Never leave erection cuts in the structure that are not on the detail plans or approved by the designer.
- 10) Don't use improper or defective materials.
- 11) Avoid leaving weld splatters, gouges or other imperfections.

#### 4.1.3 Welding:

4.1.3.1 Cracks in structural welds developed in the heat affected zones, in the weld metal, and in the base metal where irregular weld configurations caused stress concentrations. Proper design and controlled welding procedures would ensure the quality of structural welds and reduce failures associated with welding.

4.1.3.2 Welding was identified as a cause of failure in many cases. Undersized welds, poor deposits or undercutting at the

weld toe in areas of poor accessibility were the most common causes of weld failures. Other aspects of welding that are not easily recognized by visual inspection, but influence the formation of weld faults are:

- 1) Using the wrong type of electrode (this is especially true in ship structures where different material types are mixed).
- 2) Using the wrong heat input (either too high or too low for the electrode or filler metal being used).
- 3) Using an improper weld sequence that causes excessive distortion.
- 4) Using oversized welds by design, or to make up for poor fabrication.
- 5) Improper weld edge preparation on the plating or stiffener webs.
- 6) Improper weld cleaning before and between weld passes.
- 7) Improper back gouging in full penetration welds.

4.1.3.3 The weld and inspection requirements for primary structure is fully covered by the classification societies and the U.S. Navy. However, the requirements for secondary structure such as tripping stiffeners, panel stiffeners, miscellaneous openings and reinforcements are left to the designer's judgment. Failures in these welds could lead to primary structure failures. Therefore, it is imperative during design and fabrication that requirements for proper welding be given full consideration. Every effort must be made to ensure that sufficient clearances are maintained, that cutouts are sufficiently sized for the welding required, and that all special applications are noted to ensure proper welding controls and weld contours. Access must be provided to allow the welder to reach in corners and behind flanges to ensure good weld contours, and avoid blobs, weld splatters, or weld arc strikes which could become the source of a crack.

4.1.3.4 If a weld is correctly sized, deposited, and inspected, the likelihood of a flaw or crack starting because of the weld is very remote.

#### 4.1.4 Maintenance:

4.1.4.1 Failures were observed on ships that resulted directly from the lack of proper maintenance. Corrosion reduced

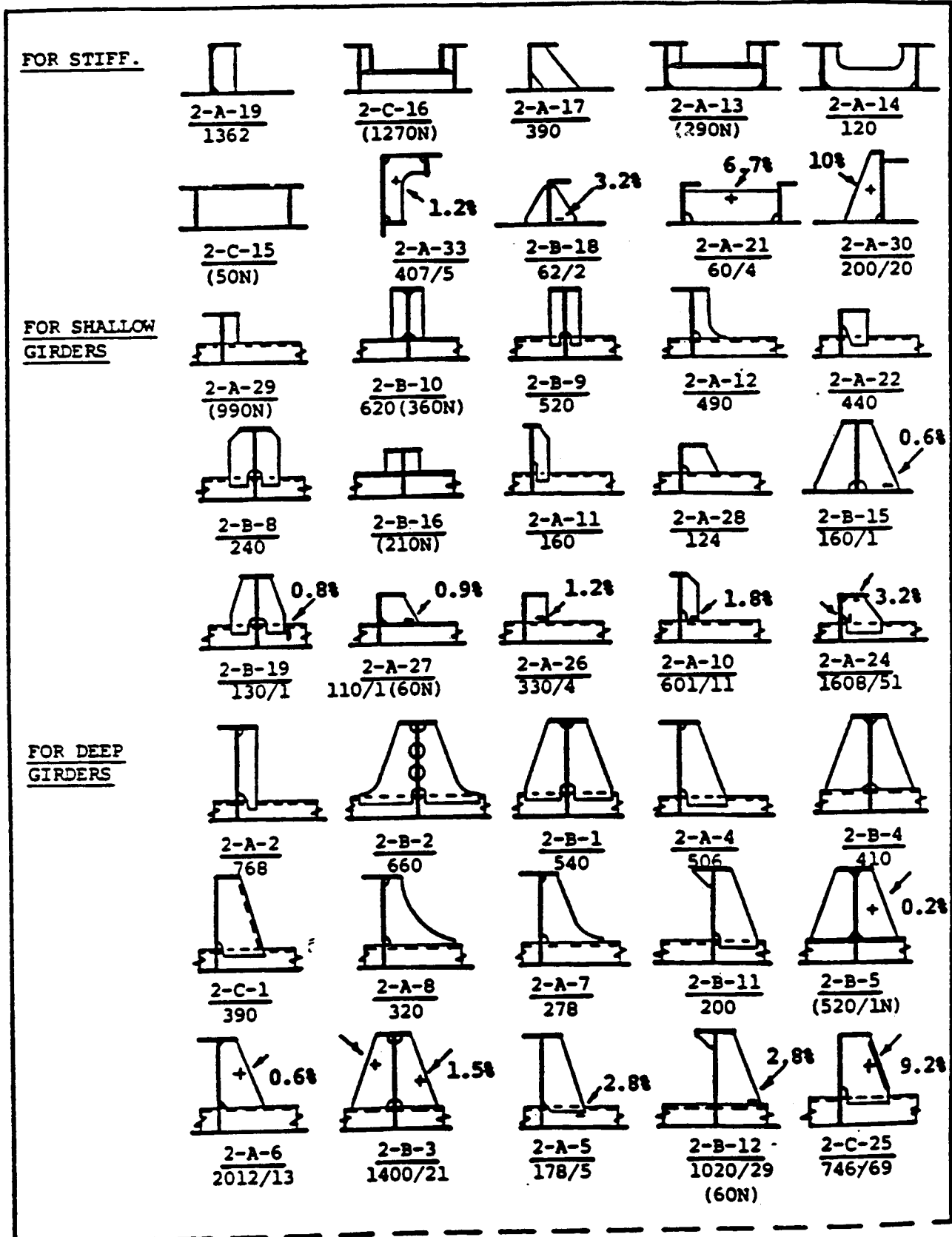

FIG. 18 Performance of Tripping Bracket Details (Family No. 2)

the scantlings of the members below the design allowances with buckles developing from instability and cracks from

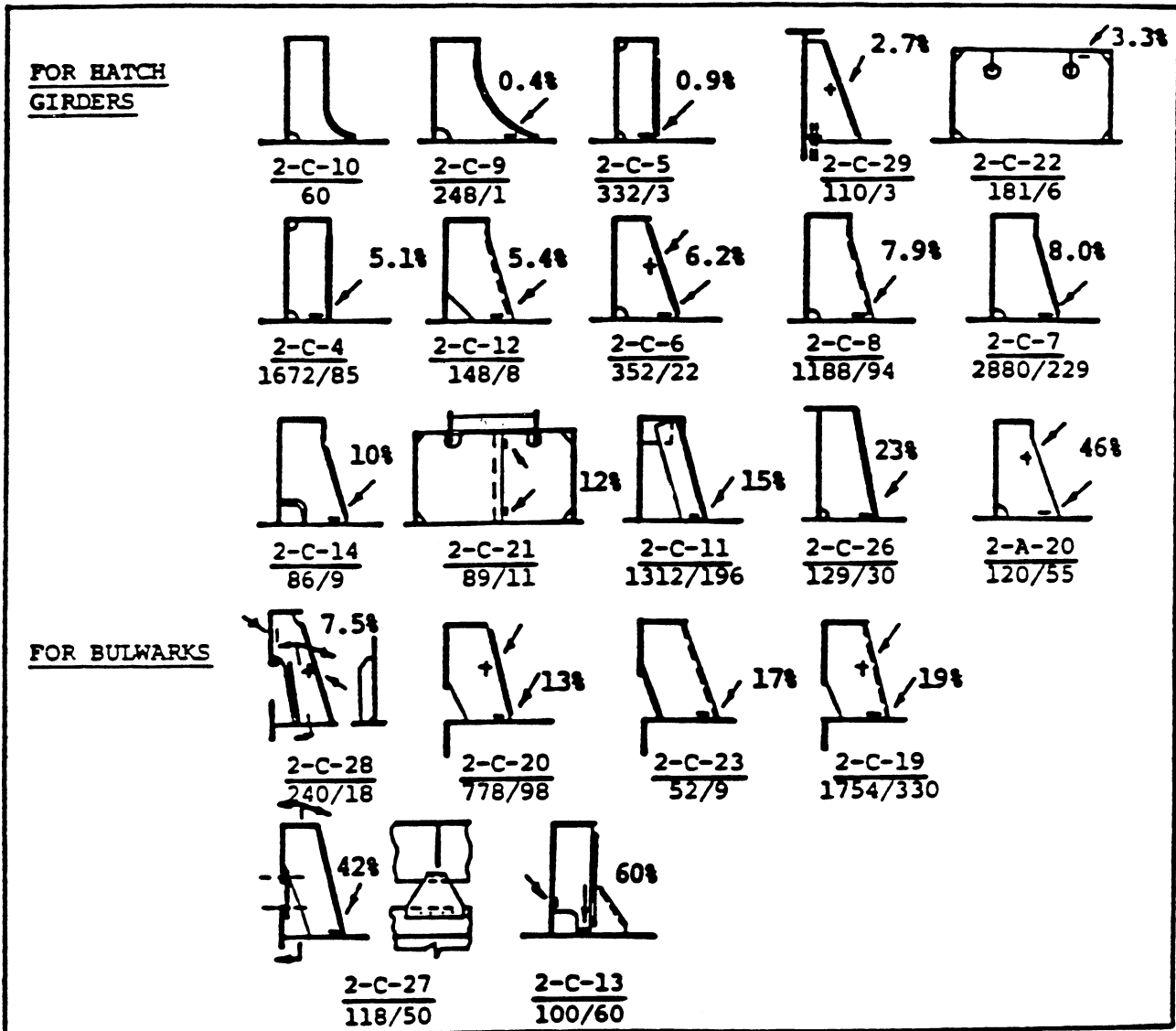

FIG. 19 Performance of Tripping Bracket Details (Family No. 2) Cont'd

excessive stress. Ship owners and operators could eliminate structural failures from such causes if they maintained protective coatings on structures subjected to the corrosive action of the sea.

4.1.4.2 Throughout the design and fabrication process, every effort should be made to eliminate:

- 1) Areas that allow standing water.
- 2) Areas that are inaccessible.
- 3) Areas with ineffective coating materials.
- 4) Areas with improper location of miscellaneous cutouts.
- 5) Areas with high residual stresses.

4.1.4.3 Specific failures were attributed to maintenance. The following are suggested corrective measures for combating the cause of such failures:

- 1) Areas used for water ballast, or subject to casual water and/or salt spray should be coated with anti-corrosive coating.
- 2) Pockets and low spots should have drain holes, air holes and drain pipes to ensure that water does not stand or pocket on decks, behind structure or tanks. At the same time, the location

of these openings should be judiciously considered to eliminate openings in high stress areas where possible and to reinforce those openings when they cannot be located out of those areas. This will reduce the effects of stress corrosion that lead to buckled plates and flanges, and the increase in stress that causes fatigue cracks.

3) Personnel access should be provided to all areas of the ship to afford the opportunity to conduct the necessary inspections and, where required, the preventive maintenance that will reduce costly repairs later.

4) Areas subjected to severe corrosion condition should be designed and fabricated to reduce areas of potential high stress which accelerate corrosion due to stress and fatigue.

4.1.5 Operations:

4.1.5.1 Details in the forward shell and forecabin areas of several ships sustained damage resulting from driving the ship at high speed in heavy weather. With the uncertainty of the slamming loads produced by such conditions, extreme care should be used in the selection, design, fabrication and

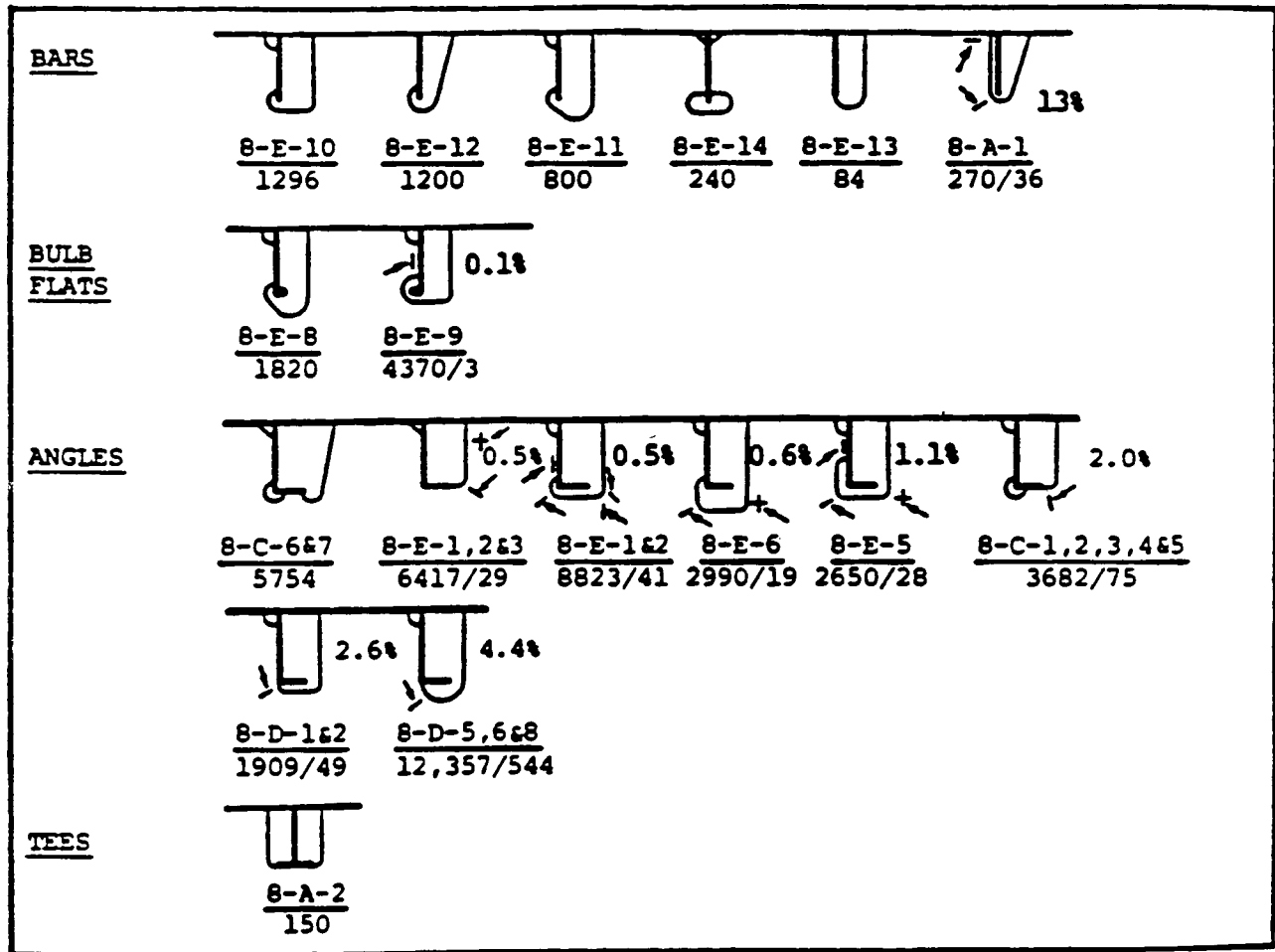

FIG. 20 Performance of Stiffener Clearance Cutout Details (Family No. 8)

maintenance of all structural connections and details used in the forward area of the ship.

4.1.5.2 The majority of these failures were caused by operators trying to maintain a predetermined schedule based on a set course and speed. Other more obvious operations failure causes included cargo handling abuse, docking (drydocking as well as pier side operations), and minor collisions (including other ships, tugs and large floating objects).

4.1.5.3 The most prominent detail failures attributed to operations were to family no. 1 beam brackets, (Fig. 14). Of the beam bracket failures 67 % were attributed to operation (heavy weather). Possible fixes for the beam brackets included the use of face plates or panel stiffeners to increase panel stability, the use of heavier plating to increase the corrosion margin and

increase panel stability, and the elimination of the indiscriminate use of lighting holes and miscellaneous cutout in areas subject to potentially high operational loading.

4.1.5.4 Tripping brackets, detail family no. 2 (Fig. 18) were the source of numerous operational failures especially in the areas of hatch side girders and bulwark brackets. These girders, which carry high concentrated loads from containers stowed two to four high, must be provided with scantlings and tripping brackets to ensure proper support and load transfer during severe weather.

## 5. Keywords

5.1 fabrication details; ship construction; structural details

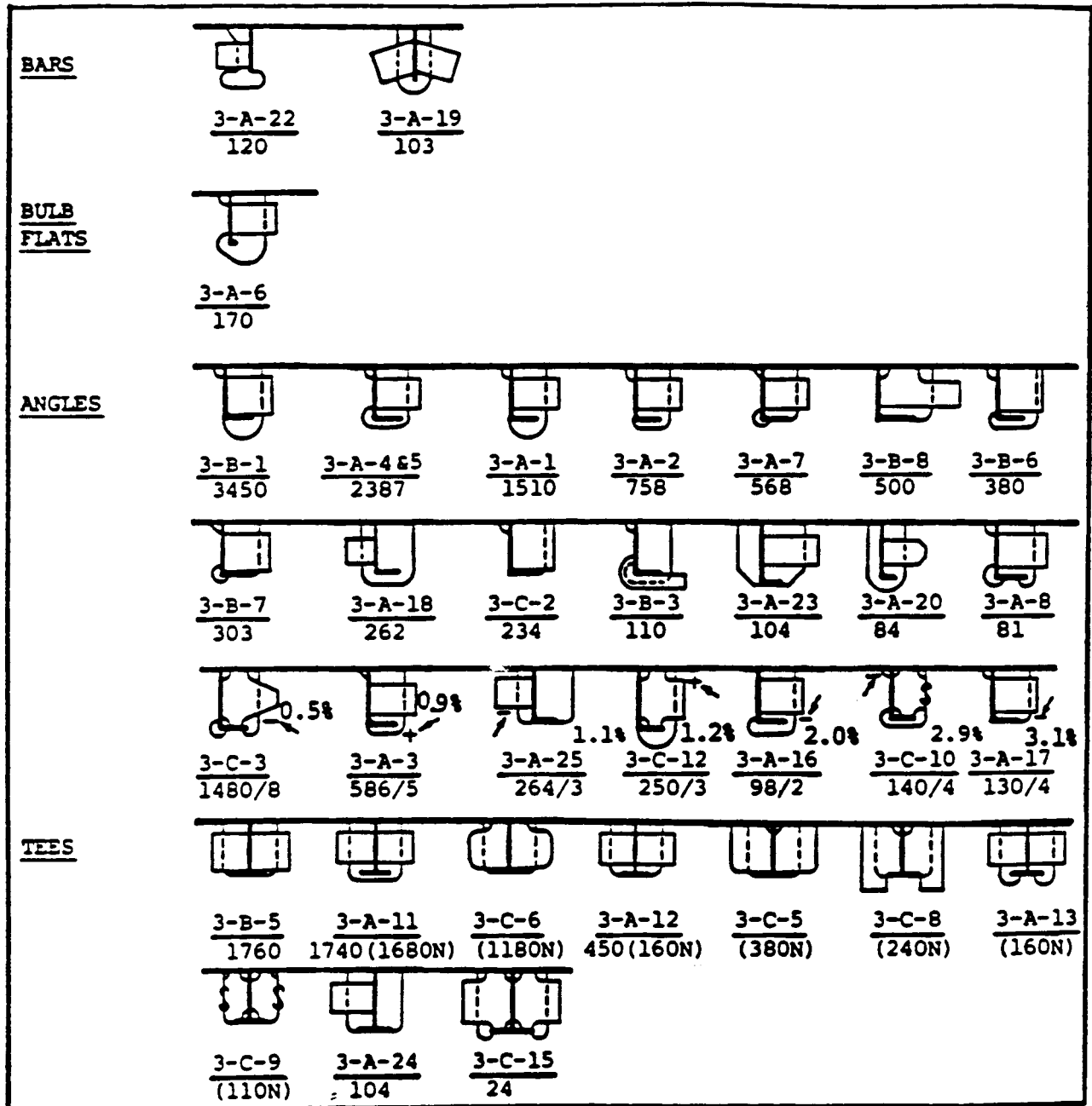

FIG. 21 Performance of Non-Tight Collar Details (Family No. 3)

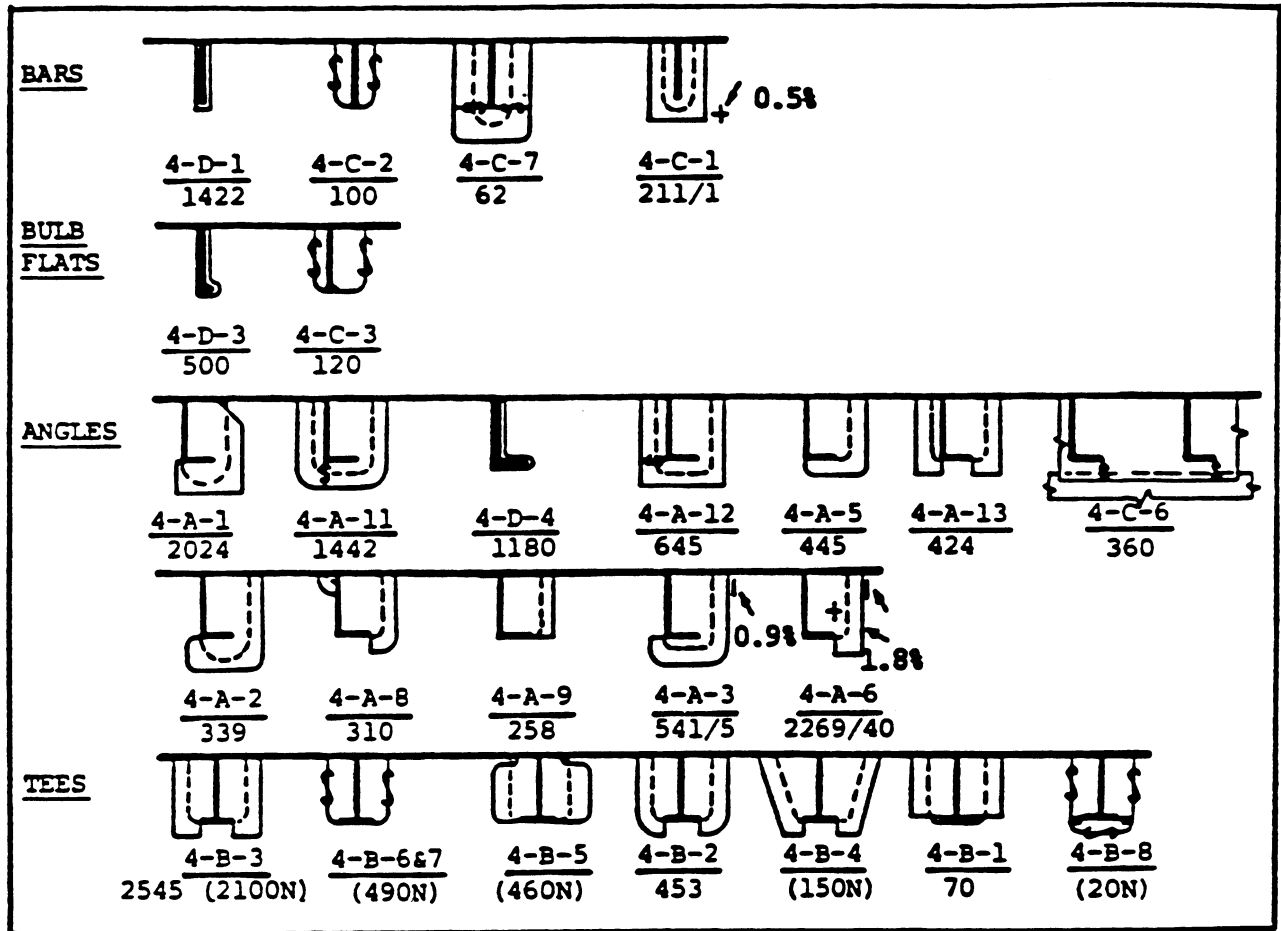

FIG. 22 Performance of Tight Collar Details (Family No. 4)

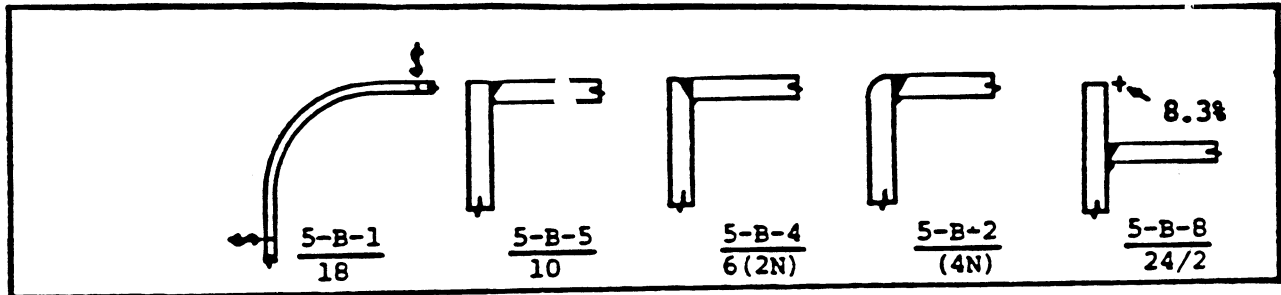

FIG. 23 Performance of Gunwale Connection Details (Family No. 5)

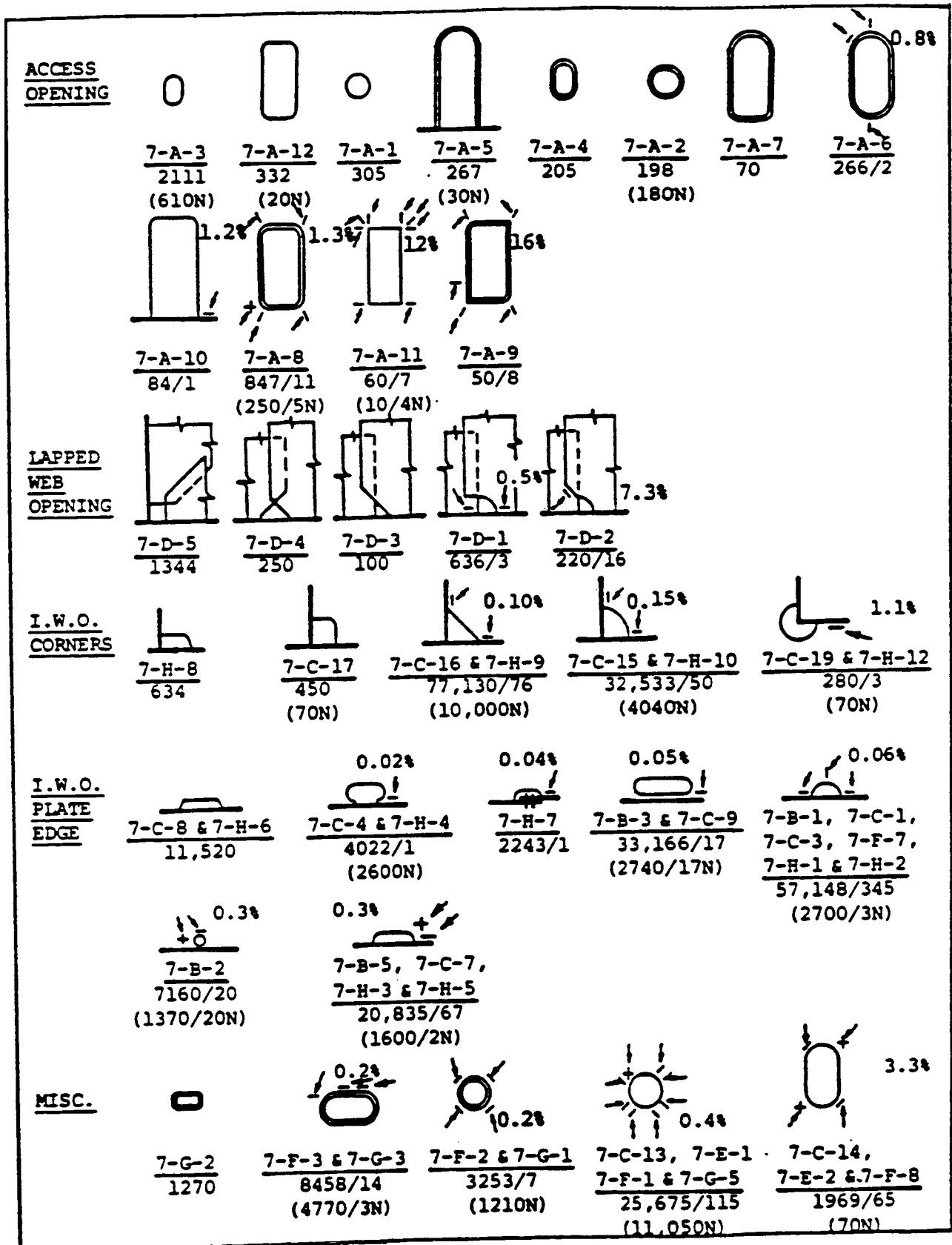

FIG. 24 Performance of Miscellaneous Cutout Details (Family No. 7)

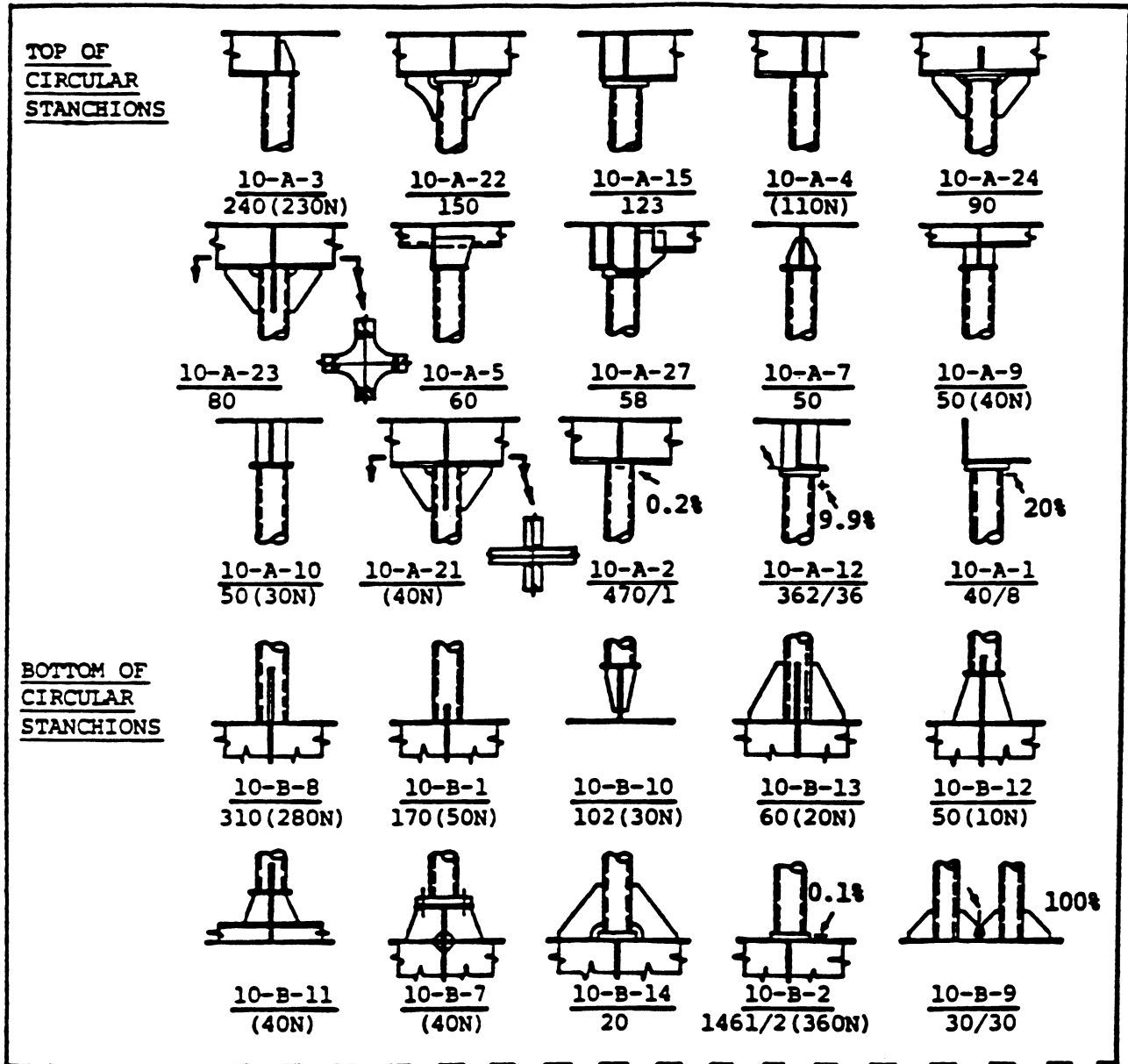

FIG. 25 Performance of Stanchion End Details (Family No. 10)

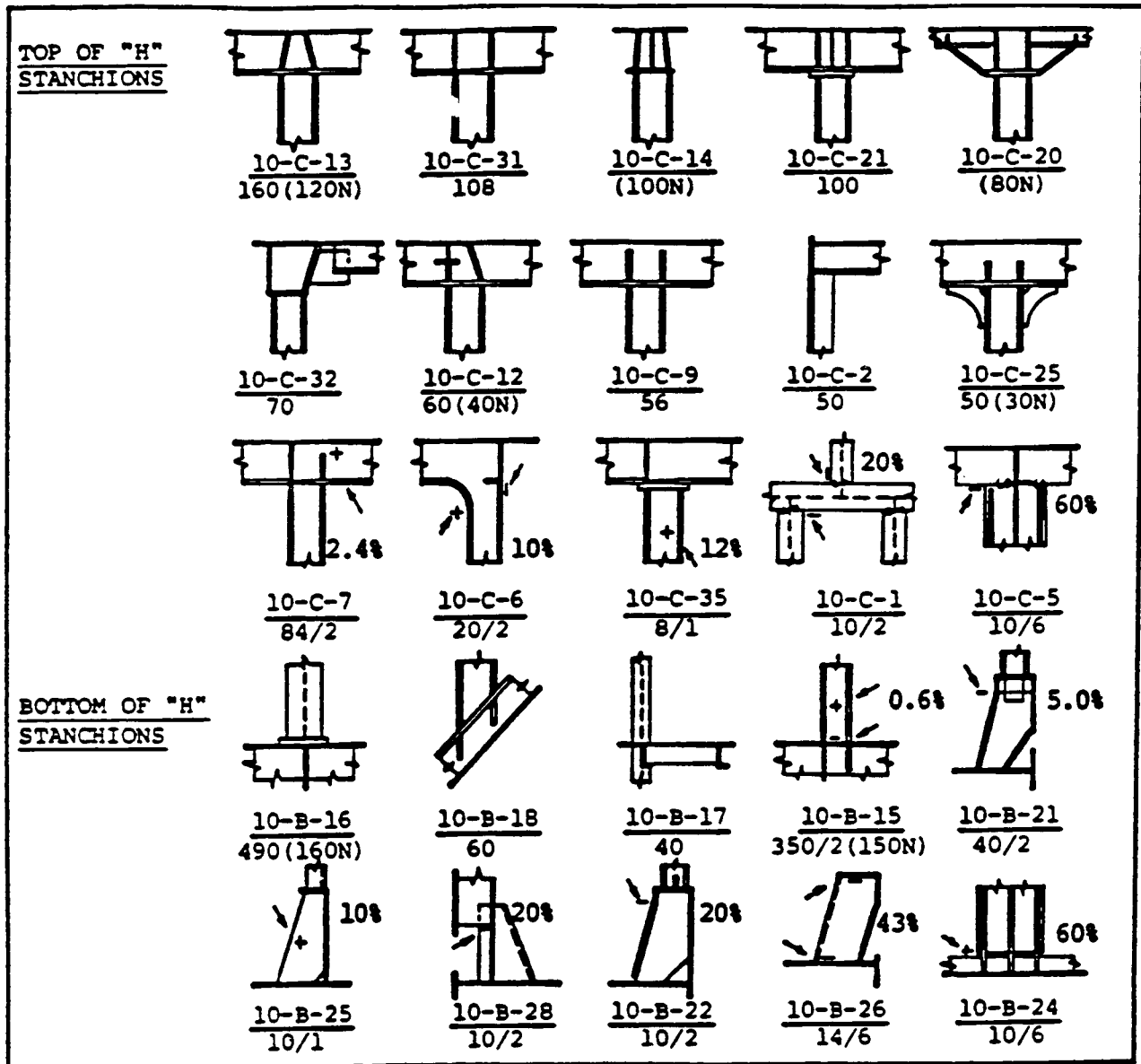

FIG. 26 Performance of Stanchion End Details (Family No. 10) Cont'd

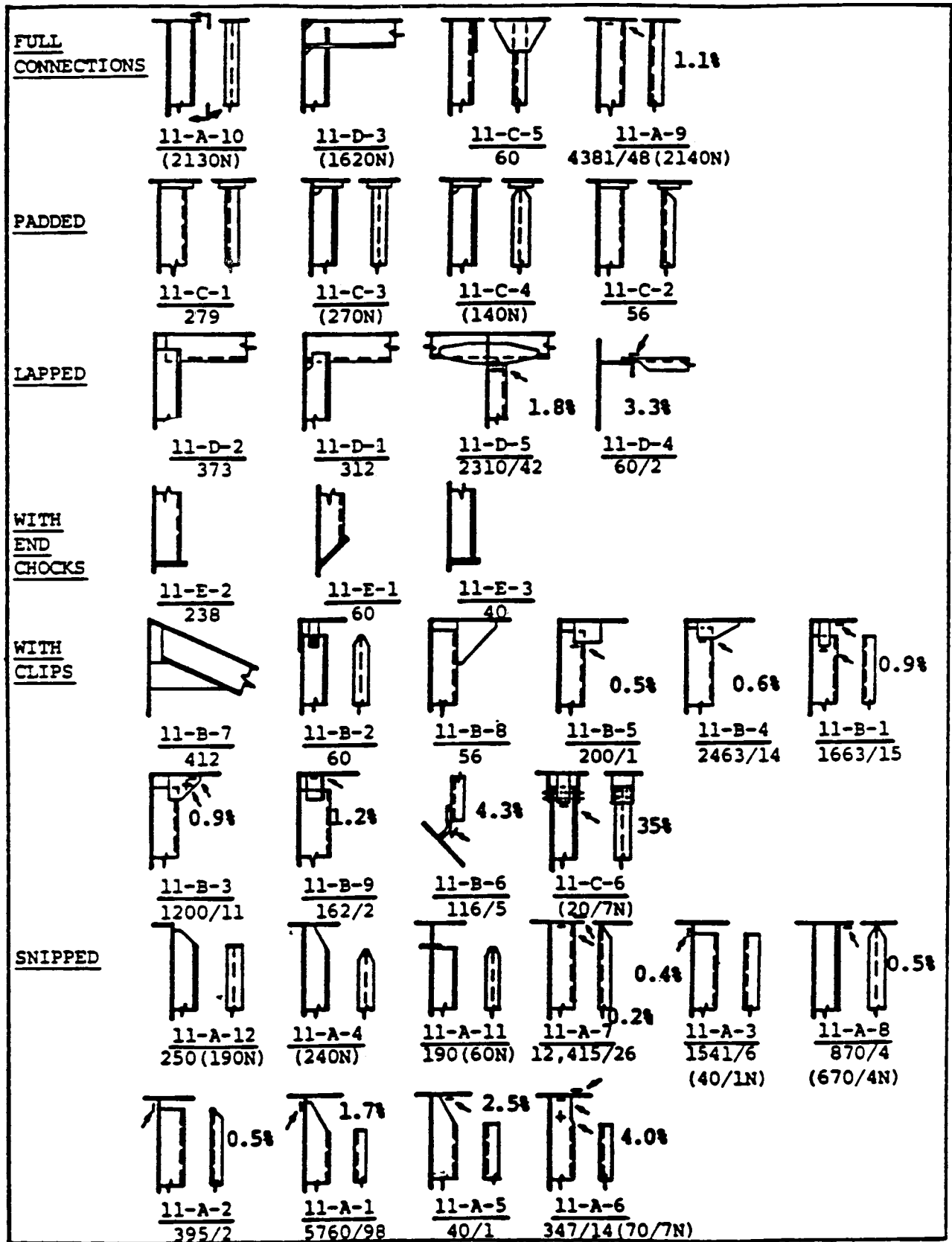

FIG. 27 Performance of Stiffener End Details (Family No. 11)

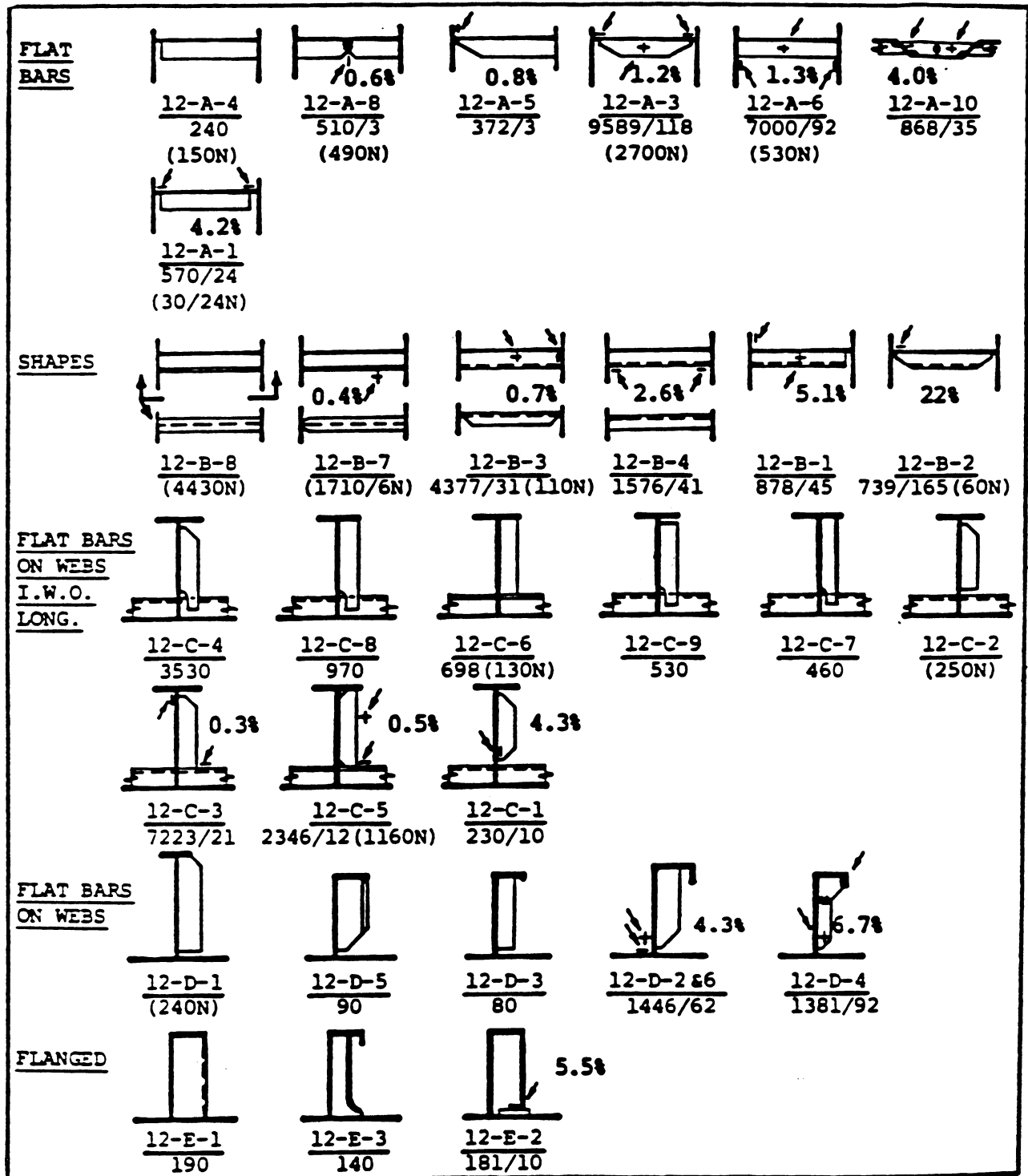



FIG. 28 Performance of Panel Stiffener Details (Family No. 12)

 **F 1455 – 92 (2001)**

*ASTM International takes no position respecting the validity of any patent rights asserted in connection with any item mentioned in this standard. Users of this standard are expressly advised that determination of the validity of any such patent rights, and the risk of infringement of such rights, are entirely their own responsibility.*

*This standard is subject to revision at any time by the responsible technical committee and must be reviewed every five years and if not revised, either reapproved or withdrawn. Your comments are invited either for revision of this standard or for additional standards and should be addressed to ASTM International Headquarters. Your comments will receive careful consideration at a meeting of the responsible technical committee, which you may attend. If you feel that your comments have not received a fair hearing you should make your views known to the ASTM Committee on Standards, at the address shown below.*

*This standard is copyrighted by ASTM International, 100 Barr Harbor Drive, PO Box C700, West Conshohocken, PA 19428-2959, United States. Individual reprints (single or multiple copies) of this standard may be obtained by contacting ASTM at the above address or at 610-832-9585 (phone), 610-832-9555 (fax), or [service@astm.org](mailto:service@astm.org) (e-mail); or through the ASTM website ([www.astm.org](http://www.astm.org)).*