



Standard Specification for Stainless Steel Socket-Set Screws¹

This standard is issued under the fixed designation F 880; the number immediately following the designation indicates the year of original adoption or, in the case of revision, the year of last revision. A number in parentheses indicates the year of last reapproval. A superscript epsilon (ϵ) indicates an editorial change since the last revision or reapproval.

This standard has been approved for use by agencies of the Department of Defense.

1. Scope

1.1 This specification covers the requirements for austenitic grade stainless steel socket-set screws (SSS) sizes 0.060 through 0.500 in., in two conditions, AF and CW.

1.2 The following hazards caveat pertains only to Test Method Section, Section 12 of this specification. *This standard does not purport to address (all of) the safety problems associated with its use. It is the responsibility of the user of this standard to establish appropriate safety and health practices and determine the applicability of regulatory limitations prior to use.*

NOTE 1—A complete metric companion to Specification F 880 has been developed—F 880M; therefore, no metric equivalents are shown in this specification.

2. Referenced Documents

2.1 ASTM Standards:

- A 262 Practices for Detecting Susceptibility to Intergranular Attack in Austenitic Stainless Steels²
- A 342 Test Methods for Permeability of Feebly Magnetic Materials³
- A 380 Practice for Cleaning, Descaling, and Passivation of Stainless Steel Parts, Equipment, and Systems²
- A 555/A 555M Specification for General Requirements for Stainless Steel Wire and Wire Rods²
- A 751 Test Methods, Practices, and Terminology for Chemical Analysis of Steel Products²
- A 967 Specification for Chemical Passivation Treatments for Stainless Steel Parts²
- D 3951 Practice for Commercial Packaging⁴
- E 18 Test Methods for Rockwell Hardness and Rockwell Superficial Hardness of Metallic Materials⁵

F 593 Specification for Stainless Steel Bolts, Hex Cap Screws, and Studs⁶

F 788/F 788M Specification for Surface Discontinuities of Bolts, Screws, and Studs, Inch and Metric Series⁶

F 1470 Guide for Fastener Sampling for Specific Mechanical Properties and Performance Inspection⁶

2.2 ASME Standard:⁷

B 18.3 Socket Cap, Shoulder and Set Screws, Inch Series

3. Classification

3.1 The designation of the alloy group and condition for the two materials and conditions of this specification shall be consistent with the stainless steel designations in Specification F 593.

3.2 The austenitic stainless steel socket set screw shall be designated F 880 Group 1 Condition AF (solution annealed) or F 880 Group 1 Condition CW (cold worked).

4. Ordering Information

4.1 Orders for material under this specification shall include the following information:

4.1.1 Quantity (number of screws);

4.1.2 Dimensions, including nominal thread designation, thread pitch, nominal screw length (inches) and point configuration. A standard part number may be used for this definition;

4.1.3 Name of the screw (SSS);

4.1.4 Condition AF/CW;

4.1.5 Surface finish, if required. If a finish other than passivation is required, it must be specified on the order or product standard;

4.1.6 ASTM specification and year of issue; and

4.1.7 Any special or supplemental requirements.

4.2 *Example*—50 000 pieces 0.250-20 \times 0.375 cone point SSS CW ASTM F 880 – XX.

5. Materials and Manufacture

5.1 The screw may be forged, formed, extruded, machined, or ground to meet the dimensional characteristics and performance requirements.

¹ This specification is under the jurisdiction of ASTM Committee F16 on Fasteners and is the direct responsibility of Subcommittee F16.04 on Nonferrous Fasteners.

Current edition approved April 10, 2002. Published May 2002. Originally published as F 880 - 86. Last previous edition F 880 - 01a.

² *Annual Book of ASTM Standards*, Vol 01.03.

³ *Annual Book of ASTM Standards*, Vol 03.04.

⁴ *Annual Book of ASTM Standards*, Vol 15.09.

⁵ *Annual Book of ASTM Standards*, Vol 03.01.

⁶ *Annual Book of ASTM Standards*, Vol 01.08.

⁷ Available from American National Standards Institute, 11 West 42nd Street, 13th Floor, New York, NY 10036.

5.2 *Heat Treatment*—Austenitic alloys Group 1 Condition AF screw shall be annealed by heating to $1900 \pm 50^\circ\text{F}$ to obtain maximum corrosion resistance and minimum permeability. The screws shall be held for a sufficient time at temperature, then cooled at a rate sufficient to prevent precipitation of the carbide and provide the properties in accordance with Table 1.

5.3 When condition CW is specified, the austenitic alloys shall be annealed as specified in 5.2, generally by the raw material manufacturer, and then cold worked to develop specific properties.

6. Chemical Composition

6.1 The analysis of the screw material shall conform to the chemical composition specified in Table 2.

6.2 Unless otherwise specified in the inquiry and purchase order (see Supplementary Requirement S2), the choice of alloy used shall be that of the fastener manufacturer as determined by his fabrication methods and material availability. The specific alloy used by the manufacturer shall be clearly identified on all certification required in the purchase order and shall have a chemical composition conforming to the limits specified in Table 2.

6.3 When chemical analysis is performed by the purchaser using finished fasteners representing each lot, the chemical contents obtained shall conform to the limits specified in Table 2 for the specific alloy. Chemical composition shall conform to the tolerances specified in Specification A 555/A 555M.

6.3.1 In the event of a discrepancy, a referee analysis of the samples for each lot as specified in 12.1 shall be made in accordance with 11.3.1.

7. Mechanical Properties

7.1 Socket-set screws, when subjected to a torque test in accordance with 12.3.1, shall withstand application of the test tightening torque specified in Table 1 without evidence of the socket reaming or the screw bursting.

7.2 The hardness limits from 70 to 95 HRB (125 to 210 DPH) for Condition AF and 96 HRB to 33 HRC (216 to 327 DPH) for Condition CW shall be met as determined using Test Methods E 18.

8. Corrosion Resistance Requirements

8.1 Carbide Precipitation:

8.1.1 Rod, bar, and wire in the austenitic alloy groups 1, 2, and 3, except the free-machining grades, 303 and 303Se, used to make fasteners in accordance with this specification shall be capable of passing the test for susceptibility to intergranular corrosion as specified in Practice E of Practices A 262.

8.1.2 As stated in Practices A 262, samples may be subjected to the faster and more severe screening test in accordance with Practice A. Failing Practice A, specimens shall be tested to Practice E and be considered satisfactory if passing Practice E.

9. Dimensions

9.1 Unless otherwise specified, the product shall conform to the requirements of ASME B 18.3.

10. Workmanship, Finish, and Appearance

10.1 *Surface Treatment*—Unless otherwise specified, screws shall be cleaned, descaled, and passivated in accordance with Practice A 380 or Specification A 967 at the option of the manufacturer.

10.2 Surface Discontinuities:

10.2.1 The surface discontinuities for these products shall conform to Specification F 788/F 788M and the additional limitations specified herein.

10.2.1.1 Processing cracks that connect the socket to the periphery of the screw are not permissible. Defects originating on the periphery with a traverse indicating a potential to intersect are not permissible. For peripheral discontinuities, the maximum depth may be $0.06 D$.

11. Number of Tests

11.1 The requirements of this specification shall be met in continuous mass production for stock and the manufacturer shall make sample inspections to ensure that the product conforms to the specified requirements. Additional tests of individual shipments of fasteners are not ordinarily necessary. A record of the individual heat of steel in each lot shall be maintained. The containers shall be coded to permit identification of the lot.

TABLE 1 Torsional Strength Requirements

Nominal Screw Size	Shortest Nominal Screw Lengths Subject to Torque Testing			Test Torque, in.-lb, min	
	Cup and Flat Points, mm	Cone and Oval Points	Half Dog Points, mm	AF	CW
0 0.060	0.109	0.125	0.109	0.3	0.6
1 0.073	0.125	0.141	0.125	0.7	1.2
2 0.086	0.125	0.141	0.141	0.7	1.2
3 0.099	0.141	0.156	0.156	1.6	3.3
4 0.112	0.141	0.172	0.156	1.6	3.3
5 0.125	0.188	0.188	0.172	3	5
6 0.138	0.172	0.203	0.188	3	5
8 0.164	0.188	0.219	0.203	9	16
10 0.190	0.188	0.250	0.234	16	26
¼ 0.250	0.250	0.312	0.297	40	67
⅜ 0.312	0.312	0.391	0.359	79	135
½ 0.375	0.375	0.438	0.438	138	237
⅝ 0.437	0.438	0.547	0.484	220	378
¾ 0.500	0.500	0.609	0.547	358	600

TABLE 2 Chemical Requirements

UNS Designation	Alloy	Composition, % maximum except as shown								
		Carbon	Manganese	Phosphorus	Sulfur	Silicon	Chromium	Nickel	Copper	Molybdenum
Austenitic Alloys										
S30300	303	0.15	2.00	0.20	0.15 min	1.00	17.0 to 19.0	8.0 to 10.0		0.60 max ^A
S30323	303Se	0.15	2.00	0.20	0.060	1.00	17.0 to 19.0	8.0 to 10.0		Se 0.15 min
S30400	304	0.08	2.00	0.045	0.030	1.00	18.0 to 20.0	8.0 to 10.5	1.00	...
S30403	304L	0.030	2.00	0.045	0.030	1.00	18.0 to 20.0	8.0 to 12.0	1.00	...
S30500	305	0.12	2.00	0.045	0.030	1.00	17.0 to 19.0	10.5 to 13.0	1.00	...
S38400	384	0.08	2.00	0.045	0.030	1.00	15.0 to 17.0	17.0 to 19.0		...
S20300	XM1	0.08	5.0 to 6.5	0.040	0.18 to 0.35	1.00	16.0 to 18.0	5.0 to 6.5	1.75 to 2.25	0.50 max ^A
S30430	18-9LW	0.10	2.00	0.045	0.030	1.00	17.0 to 19.0	8.0 to 10.0	3.0 to 4.0	...
S30433	302HQ	0.03	2.00	0.045	0.030	1.00	17.0 to 19.0	8.0 to 10.0	3.0 to 4.0	...

^A At the manufacturer's option, determined only when intentionally added.

11.2 When specified in the purchase order, the manufacturer shall furnish a test report of the last complete set of chemical analysis and mechanical tests for each stock size in each shipment.

11.3 When tests of individual shipments are required, Supplementary Requirement S1 must be specified in the inquiry and order.

11.3.1 When the purchaser does not specify the sampling plan and basis of acceptance, the following shall apply.

11.3.1.1 The lot, for purposes of selecting samples, shall consist of all products offered for inspection and testing at one time, that are of the same style, nominal diameter, thread pitch, nominal length, material type, and condition, and surface finish.

11.3.1.2 From each lot, samples shall be selected at random and tested for each requirement in accordance with the following:

Number of Pieces in Lot	Number of Samples
800 and less	1
Over 800 to 8000, incl	2
Over 8000 to 22 000, incl	3
Over 22 000	5

11.3.1.3 Should any sample fail to meet the requirements of a specified test, double the number of samples from the same lot shall be retested for the requirement(s) in which it failed. All of the additional samples shall conform to the specification or the lot shall be rejected.

11.3.1.4 If the failure of a test specimen is due to improper preparation of the specimen or an incorrect testing technique, the specimen shall be discarded and another test specimen submitted.

11.4 Corrosion Resistance Tests:

11.4.1 Unless otherwise specified, inspection for corrosion resistance shall be in accordance with the manufacturer's standard quality control practices. No specific method of inspection is required but the screws shall be produced from suitable raw material and manufactured by properly controlled practices to maintain resistance to corrosion. When corrosion tests are required, Supplementary Requirement S4 must be specified in the inquiry and order except as noted in 11.4.2.

11.4.2 Products that have been hot worked shall be solution annealed and tested to determine freedom from precipitated carbides. Not less than one corrosion test shall be made from each lot. Corrosion tests shall be performed in accordance with

Practices A 262, Practices A or E as applicable.

12. Test Methods

12.1 Chemical Analysis—The chemical composition shall be determined in accordance with Test Methods, Practices, and Terminology A 751.

12.2 The fastener manufacturer may accept the chemical analysis of each heat of raw material purchased and reported on the raw material certification furnished by the raw material producer. The fastener manufacturer is not required to do any further chemical analysis testing, provided that precise heat lot traceability has been maintained throughout the manufacturing process on each lot of fasteners produced and delivered.

12.3 Mechanical Tests:

12.3.1 For socket strength torque test, the test screw shall be assembled into a tapped hole of 5H tolerance class in a steel block (Fig. 1) until the face of the screw is flush with the top surface of the test block and the set screw bears against a firm base, such as a hardened screw installed from the opposite side of the block. The applicable hexagon key bit, in accordance with ASME B 18.3, shall be inserted to the full depth of the set screw socket and the test torque listed in Table 2 applied by means of a torque wrench. The screw shall be disassembled

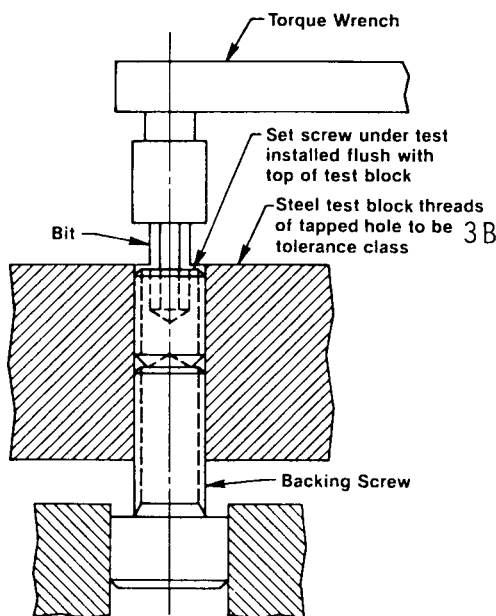

FIG. 1 Typical Torque Test Fixture

from the block and examined for compliance to the requirements of 6.1.

12.4 *Corrosion Resistance*—When specified on the purchase order or inquiry, corrosion tests to determine freedom from precipitated carbides shall be performed in accordance with Practices A 262, Practice A or E as applicable.

13. Inspection

13.1 If the inspection described in 13.2 is required by the purchaser, it shall be specified in the inquiry, order, or contract.

13.2 The inspector representing the purchaser shall have free entry to all parts of the manufacturer's works that concern the manufacture of the material ordered. The manufacturer shall afford the inspector all reasonable facilities to satisfy that the material is being furnished in accordance with this specification. All tests and inspection required by the specification that are requested by the purchaser's representative and purchase order shall be made prior to shipment and shall be so conducted as not to interfere unnecessarily with the operation of the work.

14. Rejection and Rehearing

14.1 Screws that fail to conform to the requirements of this specification may be rejected by the purchaser. Rejection shall be reported to the supplier promptly and in writing. In case of dissatisfaction with the results of tests or inspection authorized by the purchaser, the supplier may make claim for a rehearing.

15. Certification

15.1 *Test Report*—The manufacturer shall maintain on file for a period of 5 years, the original test report, including a copy of the certified chemical analysis of the heat of material used and the results of the required testing for the lot of fasteners.

15.2 *Manufacturer's Certificate of Conformance*—The manufacturer shall maintain on file for a period of 5 years, a certificate indicating that the lot of fasteners was manufactured and tested in accordance with this specification and conforms to all specified requirements.

15.3 When requested by the purchaser, submission of copies of the test report, manufacturer's certificate or an extension of the 5 year document retention period shall be performed as agreed between the manufacturer and the purchaser at the time of the inquiry or order.

16. Packaging and Package Marking

16.1 *Packaging*:

16.1.1 The manufacturer shall employ such methods of packaging the screws as may be reasonably required to ensure their receipt by the purchaser in a satisfactory condition. Unless otherwise specified packaging shall be in accordance with Practice D 3951.

16.1.2 When special packaging requirements are required by the purchaser, they shall be defined at the time of inquiry and order.

16.2 *Package Marking*—Each shipping unit shall include or be plainly marked with the following:

16.2.1 ASTM specification,

16.2.2 Alloy condition,

16.2.3 Alloy number,

16.2.4 Size,

16.2.5 Name and brand or trademark of the manufacturer,

16.2.6 Country of origin,

16.2.7 Number of pieces, and

16.2.8 Purchase order number.

SUPPLEMENTARY REQUIREMENTS

One or more of the following supplementary requirements shall apply only when specified by the purchaser in the inquiry and order (see 4.1.7). Supplementary requirements shall in no way negate any requirement of the specification itself.

S1. Shipment Lot Testing

S1.1 When Supplementary Requirement S1 is specified on the order, the manufacturer shall make sample tests on the individual lots for shipment to ensure that the product conforms to the specified requirements.

S1.2 The manufacturer shall make an analysis of a randomly selected finished fastener from each lot of product to be shipped. Heat or lot control shall be maintained. The analysis of the starting material from which the fasteners have been manufactured may be reported in place of the product analysis.

S1.3 The manufacturer shall perform mechanical property tests in accordance with this specification and Guide F 1470 on the individual lots for shipment.

S1.4 The manufacturer shall furnish a test report for each lot in the shipment showing the actual results of the chemical analysis and mechanical property tests performed in accordance with Supplementary Requirement S1.

S2. Alloy Control

S2.1 When Supplementary Requirement S2 is specified on the inquiry and order, the manufacturer shall supply that stainless steel specified on the customer's order with no group substitutions permitted without written permission by the purchaser.

S3. Permeability

S3.1 When Supplementary Requirement S3 is specified on the inquiry and order, the permeability of screws of Condition AF shall not exceed 1.05 at 100 Oe when determined by Test Methods A 342. Screws in Condition CW may not be capable of meeting permeability and hardness requirements simultaneously.

S4. Corrosion Resistance Tests

S4.1 When Supplementary Requirement S4 is specified on

the inquiry and order, corrosion test(s) shall be performed as agreed between the manufacturer and the purchaser at the time of the inquiry or order.

S5. Passivation

S5.1 When Supplementary Requirement S5 is specified on the inquiry and order, the finished product shall be passivated in accordance with Specification A 380.

ASTM International takes no position respecting the validity of any patent rights asserted in connection with any item mentioned in this standard. Users of this standard are expressly advised that determination of the validity of any such patent rights, and the risk of infringement of such rights, are entirely their own responsibility.

This standard is subject to revision at any time by the responsible technical committee and must be reviewed every five years and if not revised, either reapproved or withdrawn. Your comments are invited either for revision of this standard or for additional standards and should be addressed to ASTM International Headquarters. Your comments will receive careful consideration at a meeting of the responsible technical committee, which you may attend. If you feel that your comments have not received a fair hearing you should make your views known to the ASTM Committee on Standards, at the address shown below.

This standard is copyrighted by ASTM International, 100 Barr Harbor Drive, PO Box C700, West Conshohocken, PA 19428-2959, United States. Individual reprints (single or multiple copies) of this standard may be obtained by contacting ASTM at the above address or at 610-832-9585 (phone), 610-832-9555 (fax), or service@astm.org (e-mail); or through the ASTM website (www.astm.org).