



Designation: E 1820 – 99a01

Standard Test Method for Measurement of Fracture Toughness¹

This standard is issued under the fixed designation E 1820; the number immediately following the designation indicates the year of original adoption or, in the case of revision, the year of last revision. A number in parentheses indicates the year of last reappraisal. A superscript epsilon (ϵ) indicates an editorial change since the last revision or reappraisal.

1. Scope

1.1 This test method covers procedures and guidelines for the determination of fracture toughness of metallic materials using the following parameters: K , J , and CTOD (δ). Toughness can be measured in the R -curve format or as a point value. The fracture toughness determined in accordance with this test method is for the opening mode (Mode I) of loading.

1.2 The recommended specimens are single-edge bend, [SE(B)], compact, [C(T)], and disk-shaped compact, [DC(T)]. All specimens contain notches that are sharpened with fatigue cracks.

1.2.1 Specimen dimensional (size) requirements vary according to the fracture toughness analysis applied. The guidelines are established through consideration of material toughness, material flow strength, and the individual qualification requirements of the toughness value per values sought.

1.3 The values stated in SI units are to be regarded as the standard. The values given in parentheses are for information only.

1.4 *This standard does not purport to address all of the safety concerns, if any, associated with its use. It is the responsibility of the user of this standard to establish appropriate safety and health practices and determine the applicability of regulatory limitations prior to use.*

NOTE 1—Other standard methods for the determination of fracture toughness using the parameters K , J , and CTOD are contained in Test Methods E 399, E 813, E 1152, E 1290, and E 1737. This test method was developed to provide a common method for determining all applicable toughness parameters from a single test.

2. Referenced Documents

2.1 *ASTM Standards:*

¹ This test method is under the jurisdiction of ASTM Committee E-8 E08 on Fatigue and Fracture and is the direct responsibility of Subcommittee E08.08 on Elastic-Plastic Fracture Mechanics Technology.

Current edition approved ~~December~~ June 10, 1999; 2001. Published ~~April 2000~~ August 2001. Originally published as E 1820 - 96. Last previous edition E 1820 - 99a.

- E 4 Practices for Force Verification of Testing Machines²
- E 8 Test Methods for Tension Testing of Metallic Materials²
- E 21 Test Methods for Elevated Temperature Tension Tests of Metallic Materials²
- E 399 Test Method for Plane-Strain Fracture Toughness of Metallic Materials²
- E 813 Test Method for J_{Ic} , A Measure of Fracture Toughness²
- E 1152 Test Method for Determining J - R Curves²
- E 1290 Test Method for Crack-Tip Opening Displacement (CTOD) Fracture Toughness Measurement²
- E 1737 Test Method for J-Integral Characterization of Fracture Toughness²
- E 1823 Terminology Relating to Fatigue and Fracture Testing²
- E 1921 Test Method for Determination of Reference Temperature, T_o , for Ferric Steels in Transition Range²
- E 1942 Guide for Evaluating Data Acquisition Systems Used in Cyclic Fatigue and Fracture Mechanics Testing²

3. Terminology

3.1 Terminology E 1823 is applicable to this test method.

3.2 *Definitions:*

3.2.1 *compliance* [LF^{-1}], n —the ratio of displacement increment to load increment.

3.2.2 *crack displacement* [L], n —the separation vector between two points (on the surfaces of a deformed crack) that were coincident on the surfaces of an ideal crack in the undeformed condition.

3.2.2.1 *Discussion*—In this practice, displacement, v , is the total displacement measured by clip gages or other devices spanning the crack faces.

3.2.3 *crack extension*, Δa [L], n —an increase in crack size.

3.2.4 *crack-extension force*, G [FL^{-1} or FLL^{-2}], n —the elastic energy per unit of new separation area that is made available at the front of an ideal crack in an elastic solid during a virtual increment of forward crack extension.

3.2.5 *crack size*, a [L], n —a lineal measure of a principal planar dimension of a crack. This measure is commonly used in the calculation of quantities descriptive of the stress and displacement fields, and is often also termed crack length or depth.

3.2.5.1 *Discussion*—In practice, the value of a is obtained from procedures for measurement of physical crack size, a_p , original crack size, a_o , and effective crack size, a_e , as appropriate to the situation being considered.

3.2.6 *crack-tip opening displacement (CTOD)*, δ [L], n —the crack displacement due to elastic and plastic deformation at variously defined locations near the original (prior to an application of load) crack tip.

3.2.6.1 *Discussion*—In this test method, CTOD is the displacement of the crack surfaces normal to the original (unloaded) crack plane at the tip of the fatigue precrack, a_o . In this test method, CTOD is calculated at the original crack length, a_o , from observations away from the crack tip.

3.2.6.2 *Discussion*—In CTOD testing, δ_{Ic} [L] is a value of CTOD near the onset of slow stable crack extension, here defined as occurring at $\Delta a_p = 0.2$ mm (0.008 in.) + $0.7\delta_{Ic}$.

3.2.6.3 *Discussion*—In CTOD testing, δ_c [L] is the value of CTOD at the onset of unstable crack extension (see 3.2.17) or pop-in (see 3.2.17) when $\Delta a_p < 0.2$ mm (0.008 in.) + $0.7\delta_c$. The δ_c corresponds to the load P_c and clip-gage displacement v_c . It may be size-dependent and a function of test specimen geometry.

3.2.6.4 *Discussion*—In CTOD testing, δ_u [L] is the value of CTOD at the onset of unstable crack extension (see 3.2.28) or pop-in (see 3.2.17) when the event is preceded by $\Delta a_p > 0.2$ mm (0.008 in.) + $0.7\delta_u$. The δ_u corresponds to the load P_u and the clip gage displacement v_u . It may be size-dependent and a function of test specimen geometry. It can be useful to define limits on ductile fracture behavior.

3.2.6.5 *Discussion*—In CTOD testing, δ_m [L] is the value of CTOD at the first attainment of a maximum load plateau for fully plastic behavior. The δ_m corresponds to the load P_m and the clip gage displacement v_m . It may be size-dependent and a function of test specimen geometry. It can be useful to define limits on ductile fracture behavior.

3.2.6.6 *Discussion*—In CTOD testing, δ_c^* [L] characterizes the CTOD fracture toughness of materials at fracture instability prior to the onset of significant stable tearing crack extension. The value of δ_c^* determined by this test method represents a measure of fracture toughness at instability without significant stable crack extension that is independent of in-plane dimensions. However, there may be a dependence of toughness on thickness (length of crack front).

3.2.7 *effective thickness*, B_e [L], n —for side-grooved specimens $B_e = B - (B - B_N)^2/B$. This is used for the elastic unloading compliance measurement of crack length.

3.2.7.1 *Discussion*—This definition is different from the definition of effective thickness in Test Method E 813.

3.2.8 *effective yield strength*, σ_Y [FL^{-2}], n —an assumed value of uniaxial yield strength that represents the influence of plastic yielding upon fracture test parameters.

3.2.8.1 *Discussion*—It is calculated as the average of the 0.2 % offset yield strength σ_{YS} , and the ultimate tensile strength, σ_{TS} as follows:

$$\sigma_Y = \frac{(\sigma_{YS} + \sigma_{TS})}{2} \quad (1)$$

² Annual Book of ASTM Standards, Vol 03.01.

3.2.8.2 *Discussion*—In estimating σ_y , influences of testing conditions, such as loading rate and temperature, should be considered.

3.2.9 *J-integral, J* [FL^{-1}], n —a mathematical expression, a line or surface integral that encloses the crack front from one crack surface to the other, used to characterize the local stress-strain field around the crack front.

3.2.9.1 *Discussion*—The *J*-integral expression for a two-dimensional crack, in the x - z plane with the crack front parallel to the z -axis, is the line integral as follows:

$$J = \int_{\Gamma} \left(W dy - \bar{T} \cdot \frac{\partial \bar{u}}{\partial x} ds \right) \quad (2)$$

where:

W = loading work per unit volume or, for elastic bodies, strain energy density,

Γ = path of the integral, that encloses (that is, contains) the crack tip,

ds = increment of the contour path,

\bar{T} = outward traction vector on ds ,

\bar{u} = displacement vector at ds ,

x, y, z = rectangular coordinates, and

$\bar{T} \cdot \frac{\partial \bar{u}}{\partial x} ds$ = rate of work input from the stress field into the area enclosed by Γ .

3.2.9.2 *Discussion*—The value of *J* obtained from this equation is taken to be path-independent in test specimens commonly used, but in service components (and perhaps in test specimens) caution is needed to adequately consider loading interior to Γ such as from rapid motion of the crack or the service component, and from residual or thermal stress.

3.2.9.3 *Discussion*—In elastic (linear or nonlinear) solids, the *J*-integral equals the crack-extension force, *G*. (See *crack extension force*.)

3.2.10 J_c [FL^{-1}]—The property J_c determined by this test method characterizes the fracture toughness of materials at fracture instability prior to the onset of significant stable tearing crack extension. The value of J_c determined by this test method represents a measure of fracture toughness at instability without significant stable crack extension that is independent of in-plane dimensions; however, there may be a dependence of toughness on thickness (length of crack front).

3.2.11 J_u [FL^{-1}]—The quantity J_u determined by this test method measures fracture instability after the onset of significant stable tearing crack extension. It may be size-dependent and a function of test specimen geometry. It can be useful to define limits on ductile fracture behavior.

3.2.12 *net thickness, B_N* [L], n —distance between the roots of the side grooves in side-grooved specimens.

3.2.13 *original crack size, a_o* [L], n —the physical crack size at the start of testing.

3.2.13.1 *Discussion*—In this test method, a_{oq} is used to denote original crack size estimated from compliance.

3.2.14 *original remaining ligament, b_o* [L], n —distance from the original crack front to the back edge of the specimen, that is ($b_o = W - a_o$).

3.2.15 *physical crack size, a_p* [L], n —the distance from a reference plane to the observed crack front. This distance may represent an average of several measurements along the crack front. The reference plane depends on the specimen form, and it is normally taken to be either the boundary, or a plane containing either the load line or the centerline of a specimen or plate. The reference plane is defined prior to specimen deformation.

3.2.16 *plane-strain fracture toughness, K_{Ic}* [$FL^{-3/2}$], J_{Ic} [FL^{-1}], K_{JIc} [$FL^{-3/2}$], n —the crack-extension resistance under conditions of crack-tip plane strain.

3.2.16.1 *Discussion*—For example, in Mode I for slow rates of loading and negligible plastic-zone adjustment, plane-strain fracture toughness is the value of the stress-intensity factor designated K_{Ic} [$FL^{-3/2}$] as measured using the operational procedure (and satisfying all of the qualification requirements) specified in this test method, which provides for the measurement of crack-extension resistance at the start of crack extension and provides operational definitions of crack-tip sharpness, start of crack extension, and crack-tip plane-strain.

3.2.16.2 *Discussion*—For example, in Mode I for slow rates of loading and substantial plastic deformation, plane-strain fracture toughness is the value of the *J*-integral designated J_{Ic} [FL^{-1}] as measured using the operational procedure (and satisfying all of the qualification requirements) specified in this test method, that provides for the measurement of crack-extension resistance near the onset of stable crack extension.

3.2.16.3 *Discussion*—For example, in Mode I for slow rates of loading, plane-strain fracture toughness is the value of the stress intensity designated K_{JIc} [$FL^{-3/2}$] calculated from J_{Ic} using the equation (and satisfying all of the qualification requirements) specified in this test method, that provides for the measurement of crack-extension resistance near the onset of stable crack extension under dominant elastic conditions.⁽¹⁾³

3.2.17 *pop-in, n*—a discontinuity in the load versus clip gage displacement record. The record of a pop-in shows a sudden increase in displacement and, generally a decrease in load. Subsequently, the displacement and load increase to above their respective values at pop-in.

³ The boldface numbers in parentheses refer to a list of references at the end of this test method.

3.2.18 *R-curve or J-R curve, n*—a plot of crack extension resistance as a function of stable crack extension, Δa_p or Δa_e .

3.2.18.1 *Discussion*—In this test method, the *J-R* curve is a plot of the far-field *J*-integral versus the physical crack extension, Δa_p . It is recognized that the far-field value of *J* may not represent the stress-strain field local to a growing crack.

3.2.19 *remaining ligament, b [L], n*—distance from the physical crack front to the back edge of the specimen, that is ($b = W - a_p$).

3.2.20 *specimen center of pin hole distance, H* [L], n*—the distance between the center of the pin holes on a pin-loaded specimen.

3.2.21 *specimen gage length, d [L], n*—the distance between the points of displacement measure (for example, clip gage, gage length).

3.2.22 *specimen span, S [L], n*—the distance between specimen supports.

3.2.23 *specimen thickness, B [L], n*—the side-to-side dimension of the specimen being tested.

3.2.24 *specimen width, W [L], n*—a physical dimension on a test specimen measured from a reference position such as the front edge in a bend specimen or the load line in the compact specimen to the back edge of the specimen.

3.2.25 *stable crack extension [L], n*—a displacement-controlled crack extension beyond the stretch-zone width (see 3.2.27). The extension stops when the applied displacement is held constant.

3.2.26 *stress-intensity factor, K, K_I, K_{II}, K_{III}, K_I, K_{II}, K_{III} [FL^{-3/2}], n*—the magnitude of the ideal-crack-tip stress field (stress-field singularity) for a particular mode in a homogeneous, linear-elastic body.

3.2.26.1 *Discussion*—Values of *K* for the Modes 1, 2, and 3 are given by the following equations:

$$K_1 = \lim_{r \rightarrow 0} [\sigma_{yy} (2\pi r)^{1/2}] \quad (3)$$

$$K_2 = \lim_{r \rightarrow 0} [\tau_{xy} (2\pi r)^{1/2}] \quad (4)$$

$$K_3 = \lim_{r \rightarrow 0} [\tau_{yz} (2\pi r)^{1/2}] \quad (5)$$

where *r* = distance directly forward from the crack tip to a location where the significant stress is calculated.

3.2.26.2 *Discussion*—In this test method, Mode 1 or Mode I is assumed. See Terminology E 1823 for definition of mode.

3.2.27 *stretch-zone width, SZW [L], n*—the length of crack extension that occurs during crack-tip blunting, for example, prior to the onset of unstable brittle crack extension, pop-in, or slow stable crack extension. The SZW is in the same plane as the original (unloaded) fatigue precrack and refers to an extension beyond the original crack size.

3.2.28 *unstable crack extension [L], n*—an abrupt crack extension that occurs with or without prior stable crack extension in a standard test specimen under crosshead or clip gage displacement control.

4. Summary of Test Method

4.1 The objective of this test method is to load a fatigue precracked test specimen to induce either or both of the following responses (1) unstable crack extension, including significant pop-in, referred to as “fracture instability” in this test method; (2) stable crack extension, referred to as “stable tearing” in this test method. Fracture instability results in a single point-value of fracture toughness determined at the point of instability. Stable tearing results in a continuous fracture toughness versus crack-extension relationship (*R*-curve) from which significant point-values may be determined. Stable tearing interrupted by fracture instability results in an *R*-curve up to the point of instability.

4.2 This test method requires continuous measurement of load versus load-line displacement and crack mouth opening displacement. If any stable tearing response occurs, then an *R*-curve is developed and the amount of slow-stable crack extension shall be measured.

4.3 Two alternative procedures for measuring crack extension are presented, the basic procedure and the resistance curve procedure. The basic procedure involves physical marking of the crack advance and multiple specimens used to develop a plot from which a single point initiation toughness value can be evaluated. The basic procedure cannot be used to develop an *R*-curve. The resistance curve procedure is an elastic-compliance method where multiple points are determined from a single specimen. In the latter case, high precision of signal resolution is required; however, these data can be used to develop an *R*-curve. Other procedures for measuring crack extension are allowed.

4.4 The commonality of instrumentation and recommended testing procedure contained herein permits the application of data to more than one method of evaluating fracture toughness. Annex A4-Annex A11 define the various data treatment options that are available, and these should be reviewed to optimize data transferability.

4.5 Data that are generated following the procedures and guidelines contained in this test method are labeled qualified data. Data that meet the size criteria in Annex A4-Annex A11 are insensitive to in-plane dimensions.

4.6 Supplementary information about the background of this test method and rationale for many of the technical requirements of this test method are contained in (2). The formulas presented in this test method are applicable over the range of crack length and specimen sizes within the scope of this test method.

5. Significance and Use

5.1 Assuming the presence of a preexisting, sharp, fatigue crack, the material fracture toughness values identified by this test method characterize its resistance to: (1) fracture of a stationary crack, (2) fracture after some stable tearing, (3) stable tearing

onset, and (4) sustained stable tearing. This test method is particularly useful when the material response cannot be anticipated before the test.

5.1.1 These fracture toughness values may serve as a basis for material comparison, selection, and quality assurance. Fracture toughness can be used to rank materials within a similar yield strength range.

5.1.2 These fracture toughness values may serve as a basis for structural flaw tolerance assessment. Awareness of differences that may exist between laboratory test and field conditions is required to make proper flaw tolerance assessment.

5.2 The following cautionary statements are based on some observations.

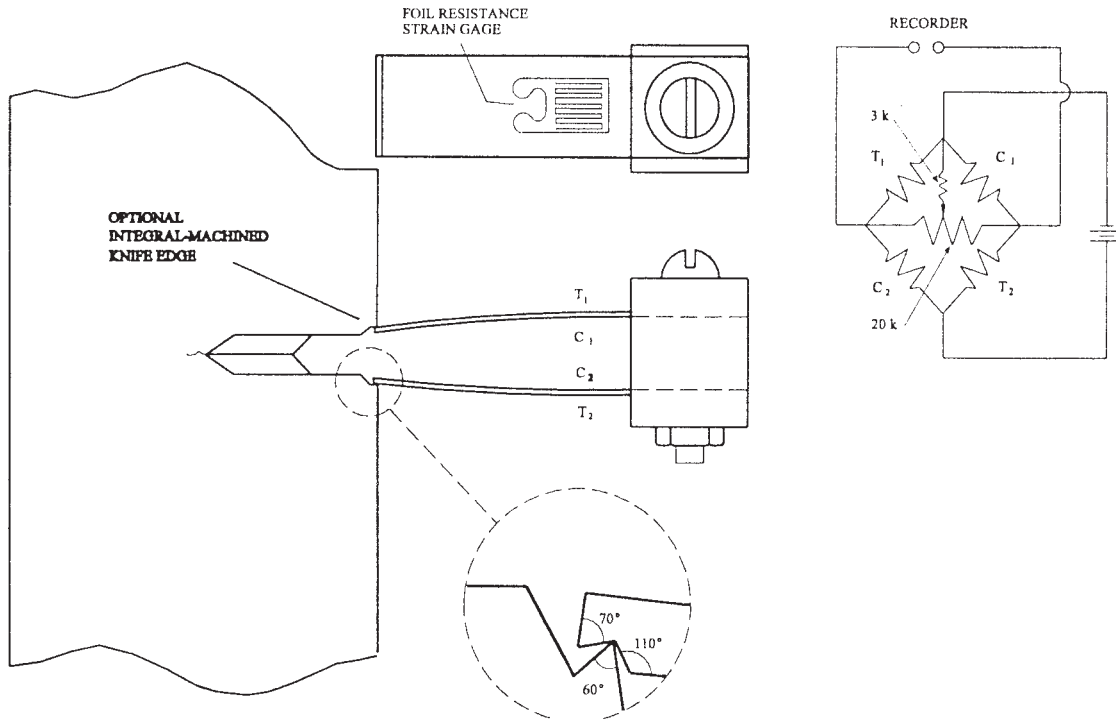

FIG. 1 Double-Cantilever Clip-In Displacement Gage Mounted By Means of Integral Knife Edges

5.2.1 Particular care must be exercised in applying to structural flaw tolerance assessment the fracture toughness value associated with fracture after some stable tearing has occurred. This response is characteristic of ferritic steel in the transition regime. This response is especially sensitive to material inhomogeneity and to constraint variations that may be induced by planar geometry, thickness differences, mode of loading, and structural details.

5.2.2 The J - R curve from bend-type specimens recommended by this test method (SE(B), C(T), and DC(T)) has been observed to be conservative with respect to results from tensile loading configurations.

5.2.3 The values of δ_c , δ_u , δ_m , and J_u may be affected by specimen dimensions.

6. Apparatus

6.1 Apparatus is required for measurement of applied load, load-line displacement, and crack-mouth opening displacement. Load versus load-line displacement and load versus crack-mouth opening displacement may be recorded digitally for processing by computer or autographically with an x - y plotter. Test fixtures for each specimen type are described in the applicable Annex.

6.2 Displacement Gages:

6.2.1 Displacement measurements are needed for the following purposes: to evaluate P_Q in the K_{Ic} evaluation, J from the area under the load versus load-line displacement record, CTOD from the load versus crack-mouth opening displacement record and, for the elastic compliance method, to infer crack extension, Δa_p , from elastic compliance calculations.

6.2.2 The recommended displacement gage has a working range of not more than twice the displacement expected during the test. When the expected displacement is less than 3.75 mm (0.15 in.), the gage recommended in Fig. 1 may be used. When a greater working range is needed, an enlarged gage such as the one shown in Fig. 2 is recommended. Accuracy shall be within $\pm 1\%$ of the full working range. In calibration, the maximum deviation of the individual data points from a fit (linear or curve) to the data shall be less than $\pm 0.2\%$ of the working range of the gage when using the elastic compliance method and $\pm 1\%$ otherwise. Knife edges are required for seating the gage. Parallel alignment of the knife edges shall be maintained to within 1° . Direct methods for load-line displacement are described in Refs (2-5).

6.2.2.1 *Gage Attachment Methods*—The specimen shall be provided with a pair of accurately machined knife edges that support the gage arms and serve as the displacement reference points. These knife edges can be machined integral with the specimen or

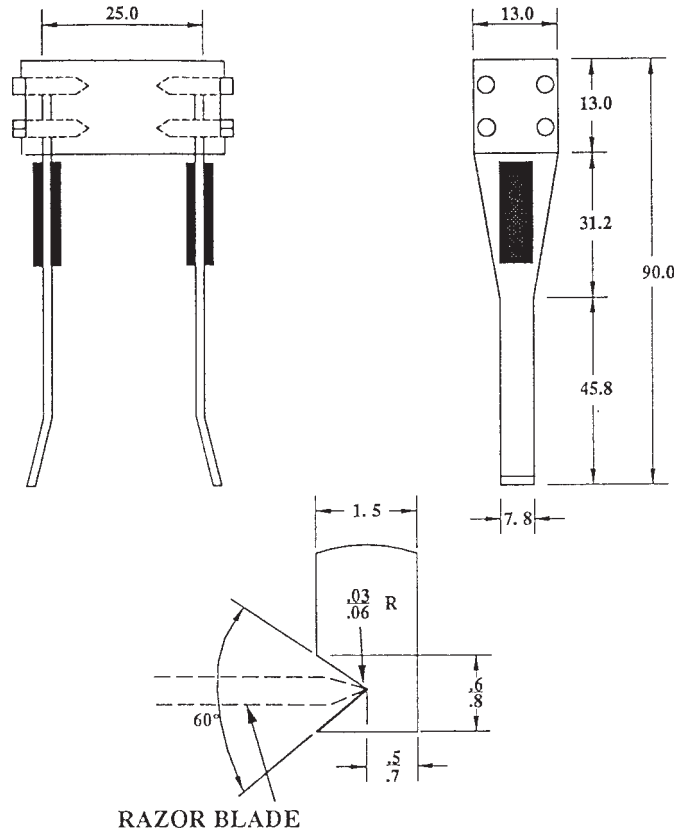

NOTE 1—All dimensions are in millimetres.
FIG. 2 Clip Gage Design for 8.0 mm (0.3 in.) and More Working Range

they may be attached separately. Experience has shown that razor blades serve as effective attachable knife edges. The knife edges shall be positively attached to the specimen to prevent shifting of the knife edges during the test method. Experience has shown that machine screws or spot welds are satisfactory attachment methods.

6.2.3 For the elastic compliance method, the recommended signal resolution for displacement should be at least 1 part in 32 000 of the transducer signal range, and signal stability should be ± 4 parts in 32 000 of the transducer signal range measured over a 10-min period. Signal noise should be less than ± 2 parts in 32 000 of the transducer signal range.

6.2.4 Gages other than those recommended in 6.2 are permissible if the required accuracy and precision can be met or exceeded.

6.3 *Load Transducers:*

6.3.1 Testing is performed in a testing machine conforming to the requirements of Practices E 4. Applied load may be measured by any load transducer capable of being recorded continuously. Accuracy of load measurements shall be within $\pm 1\%$ of the working range. In calibration, the maximum deviation of individual data points from a fit to the data shall be less than $\pm 0.2\%$ of the calibrated range of the transducer when using elastic compliance, and $\pm 1\%$ otherwise.

6.3.2 For the elastic compliance method, the signal resolution on load should be at least 1 part in 4000 of the transducer signal range and signal stability should be ± 4 parts in 4000 of the transducer signal range measured over a 10-min period. Recommended maximum signal noise should be less than ± 2 parts in 4000 of the transducer signal range.

6.4 *System Verification*—It is recommended that the performance of the load and displacement measuring systems should be verified before beginning a series of continuous tests. Calibration accuracy of displacement transducers shall be verified with due consideration for the temperature and environment of the test. Load calibrations shall be conducted periodically and documented in accordance with the latest revision of Practices E 4.

6.5 *Fixtures:*

6.5.1 *Bend-Test Fixture*—The general principles of the bend-test fixture are illustrated in Fig. 3. This fixture is designed to minimize frictional effects by allowing the support rollers to rotate and move apart slightly as the specimen is loaded, thus permitting rolling contact. Thus, the support rollers are allowed limited motion along plane surfaces parallel to the notched side of the specimen, but are initially positively positioned against stops that set the span length and are held in place by low-tension springs (such as rubber bands). Fixtures and rolls shall be made of high hardness (greater than 40 HRC) steels.

6.5.2 *Tension Testing Clevis:*

6.5.2.1 A loading clevis suitable for testing compact specimens is shown in Fig. 4. Both ends of the specimen are held in such a clevis and loaded through pins, in order to allow rotation of the specimen during testing. In order to provide rolling contact

the clevis corners may be cut off sufficiently to accommodate seating of the clip gage in specimens less than 9.5 mm (0.375 in.) thick.

6.5.2.3 Careful attention should be given to achieving good alignment through careful machining of all auxiliary gripping fixtures.

7. Specimen Size, Configuration, and Preparation

7.1 *Specimen Configurations*—The configurations of the standard specimens are shown in Annex A1-Annex A3.

7.2 *Crack Plane Orientation*—The crack plane orientation shall be considered in preparing the test specimen. This is discussed in Terminology E 1823.

7.3 *Alternative Specimens*—In certain cases, it may be desirable to use specimens having W/B ratios other than two. Suggested alternative proportions for the single-edge bend specimen are $1 \leq W/B \leq 4$ and for the compact (and diskshaped compact) specimen are $2 \leq W/B \leq 4$, however, any thickness can be used as long as the qualification requirements are met.

7.4 *Specimen Precracking*—All specimens shall be precracked in fatigue. Experience has shown that it is impractical to obtain a reproducibly sharp, narrow machined notch that will simulate a natural crack well enough to provide a satisfactory fracture toughness test result. The most effective artifice for this purpose is a narrow notch from which extends a comparatively short fatigue crack, called the precrack. (A fatigue precrack is produced by cyclically loading the notched specimen for a number of cycles usually between about 10^4 and 10^6 depending on specimen size, notch preparation, and stress intensity level.) The dimensions of the notch and the precrack, and the sharpness of the precrack shall meet certain conditions that can be readily met with most engineering materials since the fatigue cracking process can be closely controlled when careful attention is given to the known contributory factors. However, there are some materials that are too brittle to be fatigue-cracked since they fracture as soon as the fatigue crack initiates; these are outside the scope of the present test method.

7.4.1 *Fatigue Crack Starter Notch*—Three forms of fatigue crack starter notches are shown in Fig. 5. To facilitate fatigue cracking at low stress intensity levels, the root radius for a straight-through slot terminating in a V-notch should be 0.08 mm (0.003 in.) or less. If a chevron form of notch is used, the root radius may be 0.25 mm (0.010 in.) or less. In the case of a slot tipped with a hole it will be necessary to provide a sharp stress raiser at the end of the hole.

7.4.2 *Fatigue Crack Length*—The crack length (total length of the crack starter configuration plus the fatigue crack) shall be between 0.45 and 0.70 W for J and δ determination, but is restricted to the range from 0.45 to 0.55 for K_{Ic} determination. For a straight-through crack starter terminating in a V-notch (see Fig. 5), the length of the fatigue crack on each surface of the specimen shall not be less than 2.5 % of W or 1.3 mm (0.05 in.) minimum, and for a crack starter tipped with a drilled hole (see Fig. 5), the fatigue crack extension from the stress raiser tipping the hole shall not be less than 0.5 D or 1.3 mm (0.05 in.) minimum on both surfaces of the specimen, where D is the diameter of the hole. For a chevron notch crack starter (see Fig. 5), the fatigue crack shall emerge from the chevron on both surfaces of the specimen.

7.4.3 *Equipment*—The equipment for fatigue cracking should be such that the stress distribution is uniform through the specimen thickness; otherwise the crack will not grow uniformly. The stress distribution should also be symmetrical about the plane of the prospective crack; otherwise the crack may deviate from that plane and the test result can be significantly affected. The K calibration for the specimen, if it is different from the one given in this test method, shall be known with an uncertainty of less than 5 %. Fixtures used for precracking should be machined with the same tolerances as those used for testing.

7.4.4 *Fatigue Loading Requirements*—Allowable fatigue load values are based on the load P_f as defined in Annex A1-Annex A3. The fatigue precracking shall be conducted with the specimen fully heat-treated to the condition in which it is to be tested. No intermediate treatments between precracking and testing are allowed. The combination of starter notch and fatigue precrack shall conform to the requirements shown in Fig. 6. There are several ways of promoting early crack initiation: (1) by providing a very sharp notch tip, (2) by using a chevron notch (Fig. 5), (3) by statically preloading the specimen in such a way that the notch tip is compressed in a direction normal to the intended crack plane (to a load not to exceed P_f), and (4) by using a negative fatigue load ratio; for a given maximum fatigue load, the more negative the load ratio, the earlier crack initiation is likely to occur. The peak compressive load shall not exceed P_f .

7.4.5 *Fatigue Precracking Procedure*—Fatigue precracking can be conducted under either load control or displacement control. If the load cycle is maintained constant, the maximum K and the K range will increase with crack length; if the displacement cycle

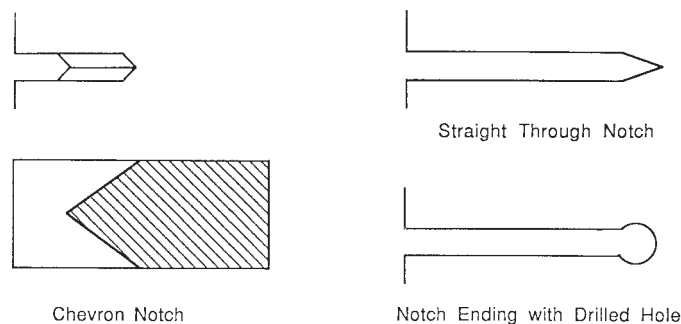
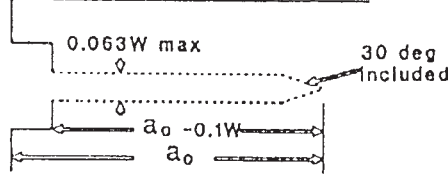

FIG. 5 Fatigue Crack Starter Notch Configurations

NOTCH AND CRACK ENVELOPE:



SUGGESTED NOTCH AND CRACK CONFIGURATIONS

	WIDE NOTCH	NARROW NOTCH
maximum notch thickness	0.063W	0.010W
maximum notch angle	60 deg	as machined
minimum precrack length	0.05 a ₀	0.05 a ₀

ACCEPTABLE NOTCH:

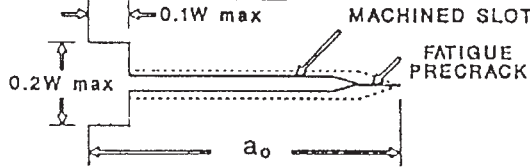

UNACCEPTABLE NOTCH:

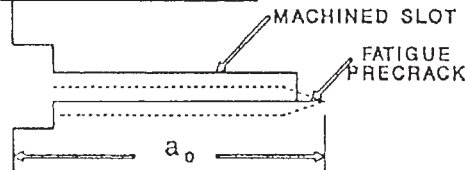

NOTE 1—The crack-starter notch shall be centered between the top and bottom specimen edges within 0.005 W.

FIG. 6 Envelope of Fatigue Crack and Crack Starter Notches

is maintained constant, the reverse will happen. The initial value of the maximum fatigue load should be less than P_f . The specimen shall be accurately located in the loading fixture. Fatigue cycling is then begun, usually with a sinusoidal waveform and near to the highest practical frequency. There is no known marked frequency effect on fatigue precrack formation up to at least 100 Hz in the absence of adverse environments. The specimen should be carefully monitored until crack initiation is observed on one side. If crack initiation is not observed on the other side before appreciable growth is observed on the first, then fatigue cycling should be stopped to try to determine the cause and find a remedy for the unsymmetrical behavior. Sometimes, simply turning the specimen around in relation to the fixture will solve the problem. The length of the fatigue precrack extension from the machined notch shall not be less than 5 % of the total crack size, a_0 , and not less than 1.3 mm (0.05 in.). For the final 50 % of fatigue precrack extension or 1.3 mm (0.05 in.), whichever is less, the maximum load shall be no larger than P_f (defined in Annex A1-Annex A3), a load such that the ratio of maximum stress intensity factor to Young's Modulus is equal to or less than $0.0002 \text{ m}^{1/2}$ (0.001 in.^{1/2}) or 70 % of the maximum load achieved during the test, whichever is less. The accuracy of these maximum load values shall be known within ± 5 %. When precracking is conducted at a temperature T_1 and testing at a different temperature T_2 , the choice of σ_Y shall take into consideration the differences in properties at the two temperatures in order to minimize yielding the specimen during precracking.

7.5 Side Grooves—Side grooves are highly recommended when the compliance method of crack length prediction is used. The specimen may also need side grooves to ensure a straight crack front as specified in Annex A4-Annex A7. The total thickness reduction shall not exceed $0.25 B$. A total reduction of $0.20 B$ has been found to work well for many materials. Any included angle of side groove less than 90° is allowed. Root radius shall be $\leq 0.5 \pm 0.2 \text{ mm}$ ($0.02 \pm 0.01 \text{ in.}$). In order to produce nearly straight fatigue precrack fronts, the precracking should be performed prior to the side-grooving operation. B_N is the minimum thickness measured at the roots of the side grooves. The root of the side groove should be located along the specimen centerline.

8. Procedure

8.1 Objective and Overview:

8.1.1 The overall objective of the test method is to develop a load-displacement record that can be used to evaluate K, J, J_c , or CTOD. Two procedures can be used:—(1) a basic procedure directed toward evaluation of a single K, J, J_c , or CTOD value without the use of crack extension measurement equipment, or—(2) a procedure directed toward evaluation of a complete fracture toughness resistance curve using crack extension measurement equipment. This also includes the evaluation of single-point toughness values.

8.1.2 The basic procedure utilizes a load versus displacement plot and is directed toward obtaining a single fracture toughness value such as K_{Tc}, J_{Tc} , or δ_{Tc} . Optical crack measurements are utilized to obtain both the initial and final physical crack sizes in this procedure. Multiple specimens can be used to evaluate J at the initiation of ductile cracking, J_{Tc} , or δ_{Tc} .

8.1.3 The resistance curve procedure utilizes an elastic unloading procedure or equivalent procedure to obtain a J - J or CTOD-based resistance curve from a single specimen. Crack length is measured from compliance in this procedure and verified by posttest optical crack length measurements. An alternative procedure using the normalization method is presented in Annex A15: Normalization Data Reduction Technique.

8.1.4 Three or more determinations of the fracture toughness parameter are suggested to ascertain the effects of material and test system variability.

8.2 *System and Specimen Preparation:*

8.2.1 *Specimen Measurement*—Measure the dimensions, B_N , B , W , H^* , and a to the nearest 0.050 mm (0.002 in.) or 0.5 %, whichever is larger.

8.2.2 *Specimen Temperature:*

8.2.2.1 The temperature of the specimen shall be stable and uniform during the test. Hold the specimen at test temperature $\pm 3^\circ\text{C}$ for $\frac{1}{2} h/25$ mm of specimen thickness.

8.2.2.2 Measure the temperature of the specimen during the test to an accuracy of $\pm 3^\circ\text{C}$, where the temperature is measured on the specimen surface within $W/4$ from the crack tip. (See Test Methods E 21 for suggestions on temperature measurement.)

8.2.2.3 For the duration of the test, the difference between the indicated temperature and the nominal test temperature shall not exceed $\pm 3^\circ\text{C}$.

8.2.2.4 The term “indicated temperature” means the temperature that is indicated by the temperature measuring device using good-quality pyrometric practice.

NOTE 2—It is recognized that specimen temperature may vary more than the indicated temperature. The permissible indicated temperature variations in 8.2.2.3 are not to be construed as minimizing the importance of good pyrometric practice and precise temperature control. All laboratories should keep both indicated and specimen temperature variations as small as practicable. It is well recognized, in view of the dependency of fracture toughness of materials on temperature, that close temperature control is necessary. The limits prescribed represent ranges that are common practice.

8.3 *Alignment:*

8.3.1 *Bend Testing*—Set up the bend test fixture so that the line of action of the applied load passes midway between the support roll centers within ± 1 % of the distance between the centers. Measure the span to within ± 0.5 % of the nominal length. Locate the specimen so that the crack tip is midway between the rolls to within 1 % of the span and square the roll axes within $\pm 2^\circ$.

8.3.1.1 When the load-line displacement is referenced from the loading jig there is potential for introduction of error from two sources. They are the elastic compression of the fixture as the load increases and indentation of the specimen at the loading points. Direct methods for load-line displacement measurement are described in Refs (3-6). If a remote transducer is used for load-line displacement measurement, take care to exclude the elastic displacement of the load-train measurement and brinelling displacements at the load points (7).

8.3.2 *Compact Testing*—Loading pin friction and eccentricity of loading can lead to errors in fracture toughness determination. The centerline of the upper and lower loading rods should be coincident within 0.25 mm (0.01 in.). Center the specimen with respect to the clevis opening within 0.76 mm (0.03 in.). Seat the displacement gage in the knife edges firmly by wiggling the gage lightly.

8.4 *Basic Procedure*—Load all specimens under displacement gage or machine crosshead or actuator displacement control. If a loading rate that exceeds that specified here is desired, please refer to Annex Annex A14: Special Requirements for Rapid-Load J-Integral Fracture Toughness Testing.

8.4.1 The basic procedure involves loading a specimen to a selected displacement level and determining the amount of crack extension that occurred during loading.

8.4.2 Load specimens at a constant rate such that the time taken to reach the load P_f lies between 0.1 and 10.0 min.

8.4.3 If the test ends by a fracture instability, measure the initial crack length and any ductile crack extension by the procedure in Section 9. Ductile crack extension may be difficult to distinguish but should be defined on one side by the fatigue precrack and on the other by the brittle region. Proceed to Section 9 to evaluate fracture toughness in terms of K , J , J , or CTOD.

8.4.4 If stable tearing occurs, test additional specimens to evaluate an initiation value of the toughness. Use the procedure in 8.5 to evaluate the amount of stable tearing that has occurred and thus determine the displacement levels needed in the additional tests. Five or more points favorably positioned are required to generate an R curve for evaluating an initiation point. See Annex A9 and Annex A11 to see how points shall be positioned for evaluating an initiation toughness value.

8.5 *Optical Crack Length Measurement:*

8.5.1 After unloading the specimen, mark the crack according to one of the following methods. For steels and titanium alloys, heat tinting at about 300°C (570°F) for 30 min works well. For other materials, fatigue cycling can be used. The use of liquid penetrants is not recommended. For both recommended methods, the beginning of stable crack extension is marked by the end of the flat fatigue precracked area. The end of crack extension is marked by the end of heat tint or the beginning of the second flat fatigue area.

8.5.2 Break the specimen to expose the crack, with care taken to minimize additional deformation. Cooling ferritic steel specimens to ensure brittle behavior may be helpful. Cooling nonferritic materials may help to minimize deformation during final fracture.

8.5.3 Along the front of the fatigue crack and the front of the marked region of stable crack extension, measure the size of the

original crack and the final physical crack size at nine equally spaced points centered about the specimen centerline and extending to 0.005 W from the root of the side groove or surface of smooth-sided specimens. Calculate the original crack size, a_o , and the final physical crack size, a_{fp} , as follows: average the two near-surface measurements, combine the result with the remaining seven crack length measurements and determine the average. The measuring instrument shall have an accuracy of 0.025 mm (0.001 in.).

8.5.4 None of the nine measurements of original crack size and final physical crack size may differ by more than 5 % from the average physical crack size defined in 8.5.3.

8.6 Resistance Curve Procedure:

8.6.1 The resistance curve procedure involves using an elastic compliance technique or other technique to obtain the J or CTOD resistance curve from a single specimen test. The elastic compliance technique is described here, while the normalization technique is described in Annex A15.

8.6.2 Load the specimens under the displacement gage or machine crosshead or actuator displacement control. Load the specimens at a rate such that the time taken to reach the load P_{ff} lies between 0.1 and 10.0 min. The time to perform an unload/reload sequence should be as needed to accurately estimate crack length, but not more than 10 min. If a higher loading rate is desired, please refer to Annex Annex A14: Special Requirements for Rapid-Load J-Integral Fracture Toughness Testing.

8.6.3 Take each specimen individually through the following steps:

8.6.3.1 Measure compliance to estimate the original crack length, a_{oa} , using unloading/reloading sequences in a load range from 0.5 to 1.0 times the maximum precracking load. Estimate a provisional initial crack size, a_{oq} , from at least three unloading/reloading sequences. No individual value shall differ from the mean by more than $\pm 0.002 W$.

8.6.3.2 Proceed with the test using unload/reload sequences that produce crack extension measurements at intervals prescribed by the applicable data analysis section of Annex A8 or Annex A10. Note that at least 8 eight data points are required before specimen achieves maximum load. If fracture instability is an expected response, then it may be helpful to load the specimen monotonically over the range $P_f < P < P_{Q-PQ}$. (See Annex A5 for a definition of P_{Q-Q}). If crack length values change negatively by more than $0.005 a_{oq}$ (backup), stop the test and check the alignment of the loading train. Crack length values determined at loads lower than the maximum precracking load should be ignored.

8.6.3.3 For many materials, load relaxation may occur prior to conducting compliance measurements, causing a time-dependent nonlinearity in the unloading slope. One method that may be used to remedy this effect is to hold the specimen for a period of time until the load becomes stable at a constant displacement prior to initiating the unloading.

8.6.3.4 The maximum recommended range of unload/reload for crack extension measurement should not exceed either 50 % of P_{ff} or 50 % of the current load, whichever is smaller.

8.6.3.5 After completing the final unloading cycle, return the load to zero without additional crosshead displacement beyond the then current maximum displacement.

8.6.3.6 After unloading the specimen, use the procedure in 8.5 to optically measure the crack lengths.

8.7 Alternative Methods:

8.7.1 Alternative methods of measuring crack extension, such as the electric potential drop method, are allowed. Methods shall meet the qualification criteria given in 9.1.5.2.

8.7.2 If displacement measurements are made in a plane other than that containing the load line, the ability to infer load-line displacement shall be demonstrated using the test material under similar test temperatures and conditions. Inferred load-line displacement values shall be accurate to within ± 1 %.

9. Analysis of Results

9.1 *Qualification of Data*—The data shall meet the following requirements to be qualified according to this test method. If the data do not pass these requirements, no fracture toughness measures can be determined in accordance with this test method.

NOTE 3—This section contains the requirements for qualification that are common for all tests. Additional qualification requirements are given with each type of test in the Annexes as well as requirements for determining whether the fracture toughness parameter developed is insensitive to in-plane dimensions.

9.1.1 All requirements on the test equipment in Section 6 shall be met.

9.1.2 All requirements on machining tolerance and precracking in Section 7 shall be met.

9.1.3 All requirements on fixture alignment, test rate, and temperature stability and accuracy in Section 8 shall be met.

9.1.4 The following crack size requirements shall be met in all tests.

9.1.4.1 *Original Crack Size*—None of the nine physical measurements of initial crack size defined in 8.5.3 shall differ by more than 5 % from the average, a_o .

9.1.4.2 *Final Crack Size*—None of the nine physical measurements of final physical crack size, a_{fp} , defined in 8.5.3 shall differ by more than 5 % from the average. In subsequent tests, the side-groove configuration may be modified within the requirements of 7.5 to facilitate meeting this requirement.

9.1.5 The following crack size requirements shall be met in the tests using the resistance curve procedure of 8.6.

9.1.5.1 *Crack Extension*—None of the nine physical measurements of crack extension shall be less than 50 % of the average crack extension.

9.1.5.2 *Crack Extension Prediction*—The crack extension predicted from elastic compliance (or other method) at the last

unloading shall be compared with the measured physical crack extension. The difference between these shall not exceed $0.15 \Delta a_p$ for crack extensions less than $0.2 b_o$, and the difference shall not exceed $0.03 b_o$ thereafter.

9.2 *Fracture Instability*—When the test terminates with a fracture instability, evaluate whether the fracture occurred before stable tearing or after stable tearing. The beginning of stable tearing is defined in A6.3 and A7.3. For fracture instability occurring before stable tearing proceed to Annex A5, Annex A6, and Annex A7 to evaluate the toughness values in terms of K , J , or CTOD. For fracture instability occurring after stable tearing, proceed to Annex A5, Annex A6, and Annex A7 to evaluate toughness values and then go to 9.3 to evaluate stable tearing.

9.3 *Stable Tearing*:

9.3.1 *Basic Procedure*—When the basic procedure is used, only an initiation toughness can be evaluated. Proceed to Annex A9 and Annex A11 to evaluate initiation toughness values.

9.3.2 *Resistance Curve Procedure*—When the resistance curve procedure is used, refer to Annex A8 and Annex A10 to develop the R curves. Proceed to Annex A9 and Annex A11 to develop initiation values of toughness.

10. Report

10.1 A recommended table for reporting results is given Fig. 7 and Fig. 8.

10.2 Report the following information for each fracture toughness determination:

10.2.1 Type of test specimen and orientation of test specimen according to Terminology E 1823 identification codes,

10.2.2 Material designation (ASTM, AISI, SAE, and so forth), material product form (plate, forging, casting, and so forth), and material yield and tensile strength (at test temperatures),

10.2.3 Specimen dimensions (8.2.1), Thickness B and B_N , and Width W ,

10.2.4 Test temperature (8.2.2), loading rate (8.4.2 and 8.6.2), and type of loading control,

10.2.5 Fatigue precracking conditions (7.4), K_{\max} , ΔK range, and fatigue precrack length (average),

10.2.6 Load-displacement record and associated calculations (Section 9),

10.2.7 Original measured crack length (8.5), original predicted crack length, a_{og} , final measured crack length, final predicted crack length, a_{fg} , physical crack extension during test, crack front appearance—straightness and planarity, and fracture appearance,

10.2.8 Qualification of fracture toughness measurement (Annex A4-Annex A7 and Annex A8-Annex A11), based on size requirements, and based on crack extension, and

10.2.9 Qualified values of fracture toughness.

Basic Test Information

Loading Rate, time to P_t = [min]
 Test Temperature = [°C]

Crack Length Information

Initial measured crack length, a_0 = [mm]
 Initial predicted crack length, a_{0c} = [mm]
 Final measured crack length, a_f = [mm]
 Final predicted crack length, a_{fc} = [mm]
 Final $\Delta a_{measured}$ = [mm]
 Final $\Delta a_{predicted}$ = [mm]

Analysis of Results

Fracture Type = (Fracture Instability or Stable Tearing)

K Based Fracture

K_{Ic} = [MPa·m^{1/2}]
 K_{IIc} = [MPa·m^{1/2}]

J Based Fracture

J_c = [kJ/m²]
 J_k = [kJ/m²]
 J_n = [kJ/m²]

 δ Based Results

$\hat{\delta}_c$ = [mm]
 δ_c = [mm]
 δ_{0c} = [mm]
 δ_n = [mm]
 δ_m = [mm]

Final $\Delta a/b$ =
 Final J_{max}/σ_{ys} = [mm]

Specimen

Type =
 Identification =
 Orientation =

Basic Dimensions

B = [mm]
 B_N = [mm]
 W = [mm]
 a_0 (Notch Length) = [mm]

Particular Dimensions

C(T) H = [mm]
 SE(B) S = [mm]
 DC(T) D = [mm]

Material

Material Designation=
 Form =

Tensile Properties

E [Young's Modulus] = [MPa]
 ν [Poisson's Ratio] =
 σ_{ys} [Yield Stress] = [MPa]
 σ_{ts} [Ultimate Stress] = [MPa]
 Tensile Test Temperature = [°C]

Precracking

Final P_{max} = [N]
 Final P_{min} = [N]
 P_t = [N]
 Final $\Delta K/E$ = [MPa m^{1/2}]
 Fatigue Temperature = [°C]
 Fatigue Crack Growth Information

FIG. 7 Suggested Data Reporting Format
11. Precision and Bias

11.1 *Bias*—There is no accepted “standard” value for any of the fracture toughness criteria employed in this test method. In the absence of such a true value no meaningful statement can be made concerning bias of data.

11.2 *Precision*—The precision of any of the various fracture toughness determinations cited in this test method is a function of the precision and bias of the various measurements of linear dimensions of the specimen and testing fixtures, the precision of the displacement measurement, the bias of the load measurement as well as the bias of the recording devices used to produce the load-displacement record, and the precision of the constructions made on this record. It is not possible to make meaningful

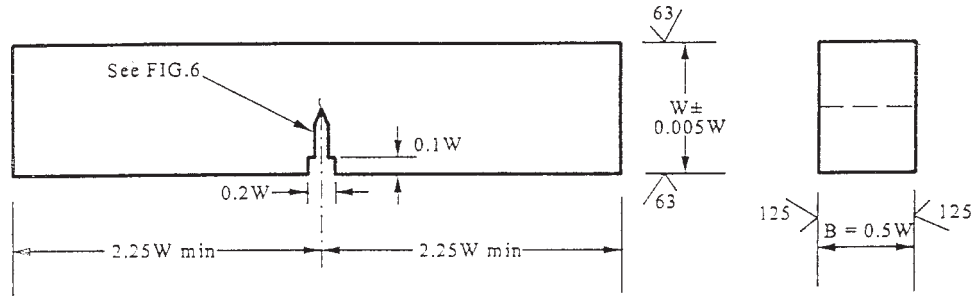

NOTE 1—The two side planes and the two edge planes shall be parallel and perpendicular as applicable to within 0.5°.
 NOTE 2—The machined notch shall be perpendicular to specimen length and thickness to within ±2°.

FIG. A1.1 Recommended Single Edge Bend [SE(B)] Specimen

A1.2 Apparatus

A1.2.1 For generally applicable specifications concerning the bend-test fixture and displacement gage see 6.5.1 and 6.2.

A1.3 Specimen Preparation:

A1.3.1 For generally applicable specifications concerning specimen configuration and preparation see Section 7.

A1.3.2 All specimens shall be precracked in three-point bending fatigue based upon the load P_f , as follows:

$$P_f = \frac{0.5Bb_o^2\sigma_Y}{S} \quad (A1.1)$$

See 7.4.5 for fatigue precracking requirements.

A1.4 Calculation

A1.4.1 Calculation of K —For the bend specimen at a load, $P_{(i)}$, calculate K as follows:

$$K_{(i)} = \left[\frac{P_i S}{(B_N)^{1/2} W^{3/2}} \right] f(a_i/W) \quad (A1.2)$$

where:

$$f(a_i/W) = \frac{3(a_i/W)^{1/2} [1.99 - (a_i/W)(1 - a_i/W) \times (2.15 - 3.93(a_i/W) + 2.7(a_i/W)^2)]}{2(1 + 2a_i/W)(1 - a_i/W)^{3/2}} \quad (A1.3)$$

A1.4.2 Calculation of J :

NOTE A1.2—In the calculation of J for the bend specimen a load-line displacement is required. For evaluating crack length, a crack mouth displacement is used.

For the single edge bend specimen, calculate J as follows:

$$J = J_{el} + J_{pl} \quad (A1.4)$$

where:

J_{el} = elastic component of J , and

J_{pl} = plastic component of J .

A1.4.2.1 J Calculations for the Basic Test Method—At a point corresponding to v and P on the specimen load versus load-line displacement, calculate as follows:

$$J = \frac{K^2 (1 - v^2)}{E} + J_{pl} \quad (A1.5)$$

where K is from A1.4.1 with $a = a_o$, and

$$J_{pl} = \frac{2A_{pl}}{B_N b_o}$$

where:

A_{pl} = area as shown in Fig. A1.2,

B_N = net specimen thickness ($B_N = B$ if no side grooves are present), and

b_o = $W - a_o$.

A1.4.2.2 J Calculations for the Resistance Curve Test Method—At a point corresponding to $a_{(i)}$, $v_{(i)}$, and $P_{(i)}$ on the specimen load versus plastic load-line displacement calculate as follows:

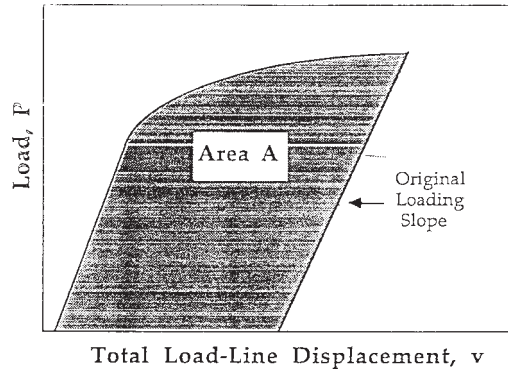

FIG. A1.2 Definition of Area for J Calculation Using the Basic Method

$$J_{(i)} = \frac{(K_{(i)})^2 (1 - v^2)}{E} + J_{pl(i)} \quad (A1.6)$$

where $K_{(i)}$ is from A1.4.1, and

$$J_{pl(i)} = \left[J_{pl(i-1)} + \left(\frac{2}{b_{(i-1)}} \right) \left(\frac{A_{pl(i)} - A_{pl(i-1)}}{B_N} \right) \right] \cdot \left[1 - \frac{a_{(i)} - a_{(i-1)}}{b_{(i-1)}} \right] \quad (A1.7)$$

In Eq A1.7, the quantity $A_{pl(i)} - A_{pl(i-1)}$ is the increment of plastic area under the load versus load-line displacement record between lines of constant displacement at points $i-1$ and i shown in Fig. A1.3. The quantity $J_{pl(i)}$ represents the total crack growth

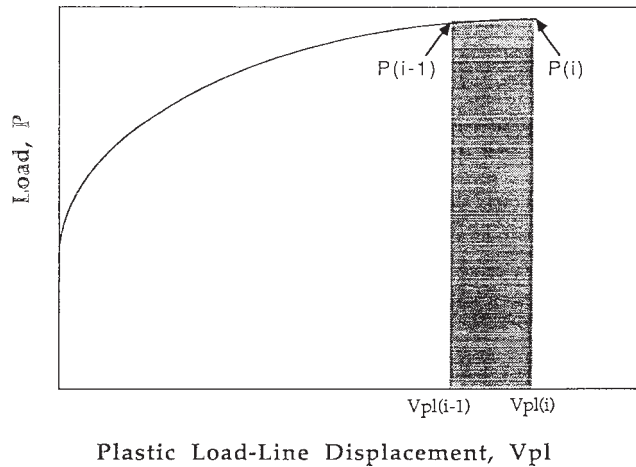

FIG. A1.3 Definition of Plastic Area for Resistance Curve J Calculation

corrected plastic J at point i and is obtained in two steps by first incrementing the existing $J_{pl(i-1)}$ and then by modifying the total accumulated result to account for the crack growth increment. Accurate evaluation of $J_{pl(i)}$ from the Eq A1.7 relationship requires small and uniform crack growth increments consistent with the suggested elastic compliance spacing of Annex A8 and Annex A10. The quantity $A_{pl(i)}$ can be calculated from the following equation:

$$A_{pl(i)} = A_{pl(i-1)} + [P_{(i)} + P_{(i-1)}] [v_{pl(i)} - v_{pl(i-1)}] / 2 \quad (A1.8)$$

where:

$v_{pl(i)}$ = plastic part of the load-line displacement = $v_{(i)} - (P_{(i)} C_{LL(i)})$, and

$C_{LL(i)}$ = slope, $(\Delta v / \Delta P)_{(i)}$, required to give the current crack length, a_i .

$C_{LL(i)}$ can be determined from knowledge of a_i/W using the following equation:

$$C_{LLi} = \frac{1}{E B_e} \left(\frac{S}{W - a_i} \right)^2 [1.193 - 1.98(a_i/W) + 4.478(a_i/W)^2 - 4.443(a_i/W)^3 + 1.739(a_i/W)^4] \quad (A1.9)$$

where:

$B_e = B - (B - B_N)^2 / B$

A1.4.3 *Calculation of Crack Length*—For a resistance curve test method using an elastic compliance technique on single edge bend specimens with crack opening displacements measured at the notched edge, the crack length is given as follows:

$$a/W = [0.999748 - 3.9504u + 2.9821u^2 - 3.21408u^3 + 51.51564u^4 - 113.031u^5] \quad (A1.10)$$

where:

$$u = \frac{1}{\left[\frac{B_e W E C_i}{S/4} \right]^{1/2} + 1} \quad (A1.11)$$

C_i = $(\Delta v_m / \Delta P)$ on an unloading/reloading sequence,
 v_m = crack opening displacement at notched edge,
 B_e = $B - (B - B_N)^2 / B$.

NOTE A1.3—Crack length on a single edge bend specimen is normally determined from crack opening compliance. It can be determined from load-line compliance if the correct calibration is available.

A1.4.4 Other compliance equations are acceptable if the resulting accuracy is equal to or greater than those described and the accuracy has been verified experimentally.

A1.4.5 *Calculation of CTOD*:

A1.4.5.1 *Calculation of CTOD for the Basic Test Method*—For the basic test method, calculations of CTOD for any point on the load-displacement curve are made from the following expression:

$$\delta = \frac{K^2 (1 - \nu^2)}{2\sigma_{YS} E} + \frac{r_p (W - a_o) v_{pl}}{[r_p (W - a_o) + a_o + z]} \quad (A1.12)$$

where:

a_o = original crack length,
 K = stress intensity factor as defined in A1.4.1 with $a = a_o$,
 ν = Poisson's ratio,
 σ_{YS} = yield or 0.2 % offset yield strength at the temperature of interest,
 E = elastic modulus at the test temperature,
 v_{pl} = plastic component of crack mouth opening displacement at the point of evaluation on the load-displacement curve, v_c , v_b , v_u , or v_m ,
 z = distance of knife edge measurement point from the notched edge on the single edge bend specimen, and
 r_p = plastic rotation factor = 0.44.

A1.4.5.2 *Calculations of CTOD for the Resistance Curve Test Method*—For the resistance curve test method, calculations of CTOD for any point on the load-displacement curve are made from the following expression:

$$\delta_{(i)} = \frac{K_{(i)}^2 (1 - \nu^2)}{2\sigma_{YS} E} + \frac{[r_p (W - a_{(i)}) + \Delta a] v_{p(i)}}{[r_p (W - a_{(i)}) + a_{(i)} + z]} \quad (A1.13)$$

where:

$a_{(i)}$ = current crack length,
 Δa = $a_{(i)} - a_o$,
 $K_{(i)}$ = stress intensity factor as defined in A1.4.1 with $a = a_{(i)}$, and the other terms are defined in A1.4.5.1.

A2. SPECIAL REQUIREMENTS FOR TESTING COMPACT SPECIMENS

A2.1 Specimen

A2.1.1 The standard compact specimen, $C(T)$, is a single edge-notched and fatigue cracked plate loaded in tension. Two specimen geometries which have been used successfully for J testing are shown in Fig. A2.1.

A2.1.2 The compact specimen in Fig. A2.2 has generally been used only for K_{Ic} testing; it has no provision for load-line displacement measurement. Do not use this specimen for ductile fracture toughness measurement. Use it only when K_{Ic} behavior is expected.

A2.1.3 Alternative specimens may have $2 \leq W/B \leq 4$ but with no change in other proportions.

A2.2 Apparatus

A2.2.1 For generally applicable specifications concerning the loading clevis and displacement gage, see 6.5.2 and 6.2.

A2.3 Specimen Preparation

A2.3.1 For generally applicable specifications concerning specimen size and preparation see Section 7.

A2.3.2 All specimens shall be precracked in fatigue at a load value based upon the load P_f as follows:

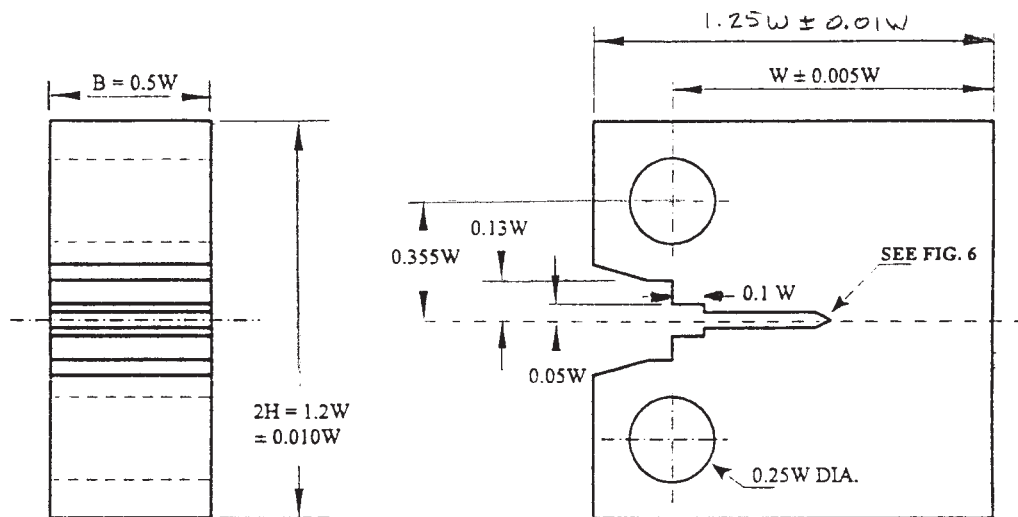

COMPACT TEST SPECIMEN FOR PIN OF 0.24W (+0.000W/-0.005W) DIAMETER

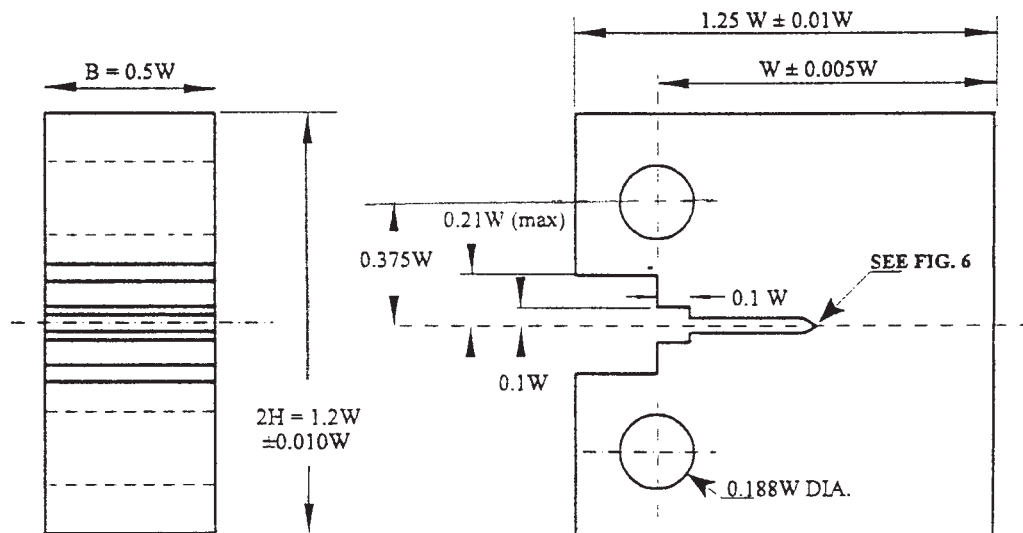

COMPACT TEST SPECIMEN FOR PIN OF 0.1875W(+0.000W/-0.001W)DIAMETER

FIG. A2.1 Two Compact Specimen Designs That Have Been Used Successfully for Fracture Toughness Testing

$$P_f = \frac{0.4Bb_o^2\sigma_Y}{(2W + a_o)} \quad (A2.1)$$

See Section 7 for fatigue precracking requirements.

A2.4 Calculation

A2.4.1 Calculation of K —For the compact specimen at a load $P_{(i)}$, calculate K as follows:

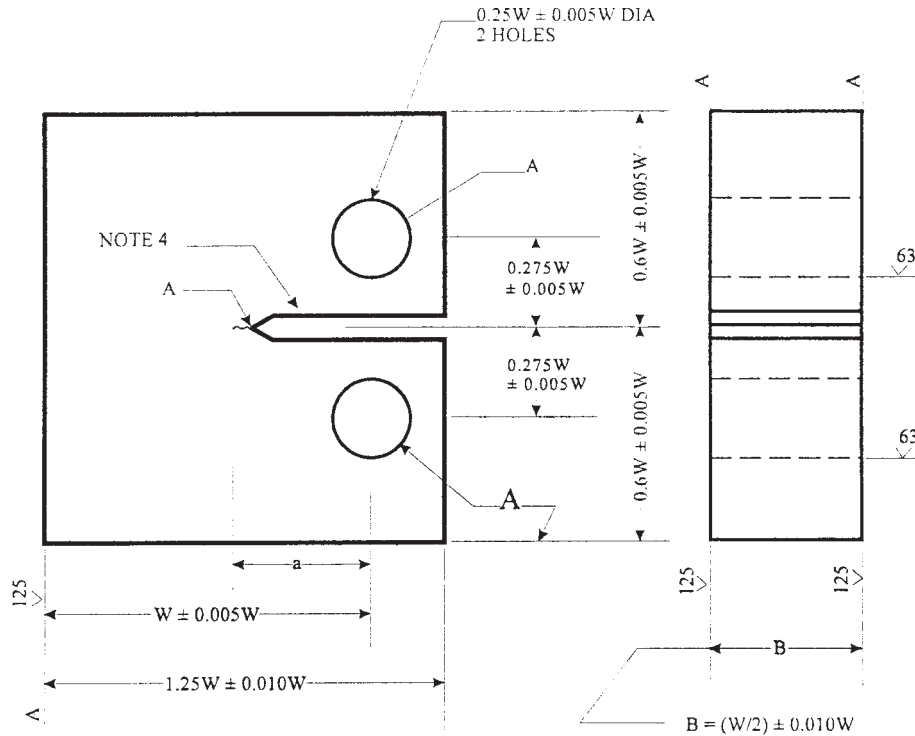

- NOTE 1—A surfaces shall be perpendicular and parallel as applicable to within 0.002 W TIR.
 NOTE 2—The intersection of the crack starter notch tips with the two specimen surfaces shall be equally distant from the top and bottom edges of the specimen within 0.005 W.
 NOTE 3—Integral or attachable knife edges for clip gage attachment to the crack mouth may be used.
 NOTE 4—For starter-notch and fatigue-crack configuration see Fig. 6.

FIG. A2.2 Compact Specimen for K_{Ic} Testing

$$K_{(i)} = \frac{P_i}{(B_N W)^{1/2}} f(a_i/W) \quad (A2.2)$$

with:

$$f(a_i/W) = \frac{[(2 + a_i/W)(0.886 + 4.64(a_i/W) - 13.32(a_i/W)^2 + 14.72(a_i/W)^3 - 5.6(a_i/W)^4)]}{(1 - a_i/W)^{3/2}} \quad (A2.3)$$

A2.4.2 Calculation of J —For the compact specimen calculate J as follows:

$$J = J_{el} + J_{pl} \quad (A2.4)$$

where:

- J_{el} = elastic component of J , and
 J_{pl} = plastic component of J .

A2.4.2.1 J Calculations for the Basic Test Method—For the compact specimen at a point corresponding to v, P on the specimen load versus load-line displacement record calculate as follows:

$$J = \frac{K^2(1 - v^2)}{E} + J_{pl} \quad (A2.5)$$

where:

K is from A2.4.1 with $a = a_o$, and

$$J_{pl} = \frac{\eta A_{pl}}{B_N b_o} \quad (A2.6)$$

where:

- A_{pl} = Area A as shown in Fig. A1.2,
 B_N = net specimen thickness ($B_N = B$ if no side grooves are present),
 b_o = uncracked ligament, ($W - a_o$), and

$$\eta = 2 + 0.522b_0/W.$$

A2.4.2.2 *J Calculation for the Resistance Curve Test Method*—For the $C(T)$ specimen at a point corresponding $a_{(i)}$, $v_{(i)}$, and $P_{(i)}$ on the specimen load versus load-line displacement record calculate as follows:

$$J_{(i)} = \frac{(K_{(i)})^2 (1 - v^2)}{E} + J_{pl(i)} \quad (A2.7)$$

where $K_{(i)}$ is from A2.4.1, and:

$$J_{pl(i)} = \left[J_{pl(i-1)} + \left(\frac{\eta_{(i-1)}}{b_{(i-1)}} \right) \frac{A_{pl(i)} - A_{pl(i-1)}}{B_N} \right] \cdot \left[1 - \gamma_{(i-1)} \frac{a_{(i)} - a_{(i-1)}}{b_{(i-1)}} \right] \quad (A2.8)$$

where:

$$\eta_{(i-1)} = 2.0 + 0.522 b_{(i-1)}/W, \text{ and}$$

$$\gamma_{(i-1)} = 1.0 + 0.76 b_{(i-1)}/W.$$

In Eq A2.8, the quantity $A_{pl(i)} - A_{pl(i-1)}$ is the increment of plastic area under the load versus plastic load-line displacement record between lines of constant displacement at points $i-1$ and i shown in Fig. A1.3. The quantity $J_{pl(i)}$ represents the total crack growth corrected plastic J at point i and is obtained in two steps by first incrementing the existing $J_{pl(i-1)}$ and then by modifying the total accumulated result to account for the crack growth increment. Accurate evaluation of $J_{pl(i)}$ from the above relationship requires small and uniform crack growth increments consistent with the suggested elastic compliance spacing of Annex A8 and Annex A10. The quantity $A_{pl(i)}$ can be calculated from the following equation:

$$A_{pl(i)} = A_{pl(i-1)} + \frac{[P_{(i)} + P_{(i-1)}] [v_{pl(i)} - v_{pl(i-1)}]}{2} \quad (A2.9)$$

where:

$v_{pl(i)}$ = plastic part of the load-line displacement, $v_i - (P_{(i)} C_{LL(i)})$, and

$C_{LL(i)}$ = compliance, $(\Delta v/\Delta P)_i$ required to give the current crack length, a_i .

$C_{LL(i)}$ can be determined from knowledge of a_i/W using the following equation:

$$C_{LL(i)} = \frac{1}{EB_e} \left(\frac{W + a_i}{W - a_i} \right)^2 [2.1630 + 12.219(a_i/W) - 20.065(a_i/W)^2 - 0.9925(a_i/W)^3 + 20.609(a_i/W)^4 - 9.9314(a_i/W)^5] \quad (A2.10)$$

where:

$$B_e = B - \frac{(B - B_N)^2}{B} \quad (A2.11)$$

In an elastic compliance test, the rotation corrected compliance, $C_c(i)$, described in A2.4.4 shall be used instead of $C_{LL(i)}$ in Eq A2.10.

A2.4.3 *Calculation of Crack Length*—For a single specimen test method using an elastic compliance technique on the compact specimen with crack opening displacements measured on the load line, the crack length is given as follows:

$$a_i/W = [1.000196 - 4.06319u + 11.242u^2 - 106.043u^3 + 464.335u^4 - 650.677u^5] \quad (A2.12)$$

where:

$$u = \frac{1}{[B_e E C_{c(i)}]^{1/2} + 1} \quad (A2.13)$$

$C_{c(i)}$ = specimen load-line crack opening elastic compliance $(\Delta v/\Delta P)$ on an unloading/reloading sequence corrected for rotation (see A2.4.4),

$$B_e = B - (B - B_N)^2/B.$$

A2.4.4 To account for crack opening displacement in $C(T)$ specimens, the crack length estimation shall be corrected for rotation. Compliance is corrected as follows:

$$C_{c(i)} = \frac{C_i}{\left[\frac{H^*}{R} \sin\theta_i - \cos\theta_i \right] \left[\frac{D}{R} \sin\theta_i - \cos\theta_i \right]} \quad (A2.14)$$

where (Fig. A2.3):

- C_i = measured specimen elastic compliance (at the load-line),
- H^* = initial half-span of the load points (center of the pin holes),
- R = radius of rotation of the crack centerline, $(W + a)/2$, where a is the updated crack length,
- D = one half of the initial distance between the displacement measurement points,
- θ = angle of rotation of a rigid body element about the unbroken midsection line, or

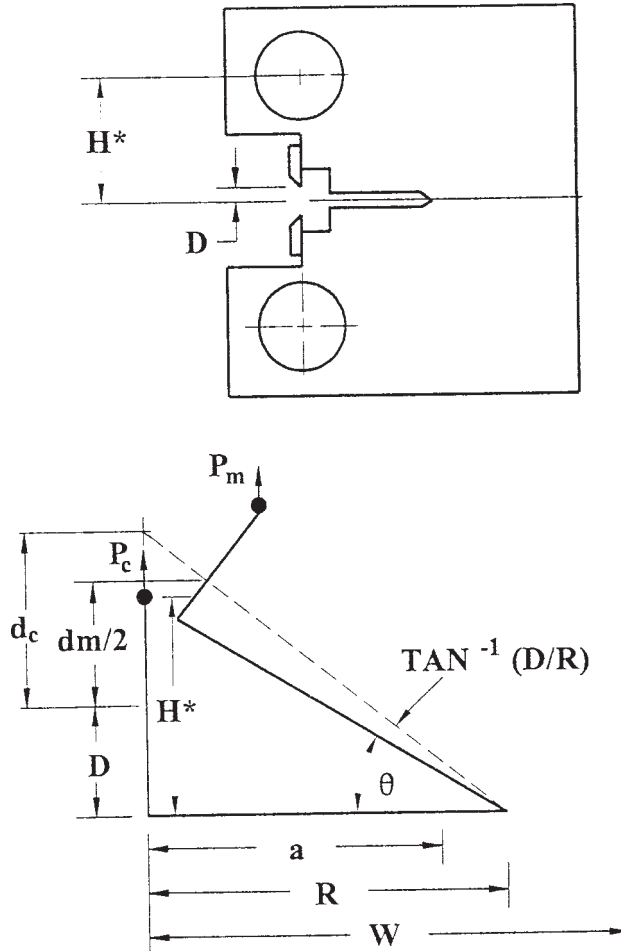

FIG. A2.3 Elastic Compliance Correction for Specimen Rotation

$$\theta = \sin^{-1} \left[\frac{\left(\frac{d_m}{2} + D \right)}{(D^2 + R^2)^{1/2}} \right] - \tan^{-1} \left(\frac{D}{R} \right), \text{ and} \tag{A2.15}$$

d_m = total measured load-line displacement.

A2.4.5 Other compliance equations are acceptable if the resulting accuracy is equal to or greater than those described and the accuracy has been verified experimentally.

A2.4.6 Calculation of CTOD:

A2.4.6.1 Calculation of CTOD for the Basic Test Method—For the basic test method, calculations of CTOD for any point on the load-displacement curve are made from the following expression:

$$\delta_{(i)} = \frac{K_{(i)}^2(1 - \nu^2)}{2\sigma_{YS}E} + \frac{[r_p(W - a_o)] \nu_{pl(i)}}{[r_p(W - a_o) + a_o + z]} \tag{A2.16}$$

where:

- a_o = original crack length,
- K = stress intensity factor as defined in A2.4.1 with $a = a_o$,

ν = Poisson's ratio,
 σ_{YS} = yield or 0.2 % offset yield strength at the temperature of interest,
 E = elastic modulus at the test temperature,
 v_{pl} = plastic component of clip gage opening displacement at the point of evaluation on the load-displacement curve, v_c , v_u ,
 or v_m ,
 z = distance of knife-edge measurement point from the load-line on the $C(T)$ specimen, and
 r_p = plastic rotation factor = 0.4 (1 + α),
 where:

$$\alpha = 2 \left[\left(\frac{a_o}{b_o} \right)^2 + \frac{a_o}{b_o} + \frac{1}{2} \right]^{1/2} - 2 \left(\frac{a_o}{b_o} + \frac{1}{2} \right) \quad (A2.17)$$

A2.4.6.2 Calculation of CTOD for the Resistance Curve Test Method—For the resistance curve test method, calculations of CTOD for any point on the load-displacement curve are made from the following expression:

$$\delta_{(i)} = \frac{K_{(i)}^2(1 - \nu^2)}{2\sigma_{YS}E} + \frac{[r_{p(i)}(W - a_{(i)}) + \Delta a]v_{pl(i)}}{[r_{p(i)}(W - a_{(i)}) + a_{(i)} + z]} \quad (A2.18)$$

where:

Δa = $a_{(i)} - a_o$,
 $K_{(i)}$ = stress intensity factor as defined in A2.4.1, with $a = a_{(i)}$, and
 $r_{p(i)}$ = plastic rotation factor = 0.4 (1 + $\alpha_{(i)}$),
 where

$$\alpha_{(i)} = 2 \left[\left(\frac{a_{(i)}}{b_{(i)}} \right)^2 + \frac{a_{(i)}}{b_{(i)}} + \frac{1}{2} \right]^{1/2} - 2 \left(\frac{a_{(i)}}{b_{(i)}} + \frac{1}{2} \right) \quad (A2.19)$$

and the other terms are defined in A2.4.6.1.

A3. SPECIAL REQUIREMENTS FOR TESTING DISK-SHAPED COMPACT SPECIMENS

A3.1 Specimen

A3.1.1 The standard disk-shaped compact specimen, DC(T), is a single edge-notched and fatigue cracked plate loaded in tension. The specimen geometry which has been used successfully is shown in Fig. A3.1.

A3.1.2 Alternative specimens may have $2 \leq W/B \leq 4$ but with no change in other proportions.

A3.2 Apparatus

A3.2.1 For generally applicable specifications concerning the loading clevis and displacement gage see 6.5.2 and 6.2.

A3.3 Specimen Preparation

A3.3.1 For generally applicable specifications concerning specimen size and preparation, see Section 7.

A3.3.2 All specimens shall be precracked in fatigue at a load value based upon the load P_f as follows:

$$P_f = \frac{0.4Bb_o^2\sigma_Y}{(2W + a_o)} \quad (A3.1)$$

See 7.4 for precracking requirements.

A3.4 Procedure

A3.4.1 *Measurement*—The analysis assumes the specimen was machined from a circular blank, and, therefore, measurements of circularity as well as width, W ; crack length, a ; and thicknesses, B and B_N , shall be made. Measure the dimensions B_N and B to the nearest 0.05 mm (0.002 in.) or 0.5 %, whichever is larger.

A3.4.1.1 The specimen blank shall be checked for circularity before specimen machining. Measure the diameter at eight equally spaced points around the circumference of the specimen blank. One of these measurements shall lie in the intended notch plane. Average these readings to obtain the diameter, D . If any measurement differs from the average diameter, D , by more than 5 %, machine the blank to the required circularity. Otherwise, $D = 1.35 W$.

A3.4.1.2 Measure the width, W , and the crack length, a , from the plane of the centerline of the loading holes (the notched edge is a convenient reference line but the distance from the centerline of the holes to the notched edge must be subtracted to determine W and a). Measure the width, W , to the nearest 0.05 mm (0.002 in.) or 0.5 %, whichever is larger.

A3.5 Calculation

A3.5.1 *Calculation of K* —For the DC(T) specimen at a load $P_{(i)}$, calculate K as follows:

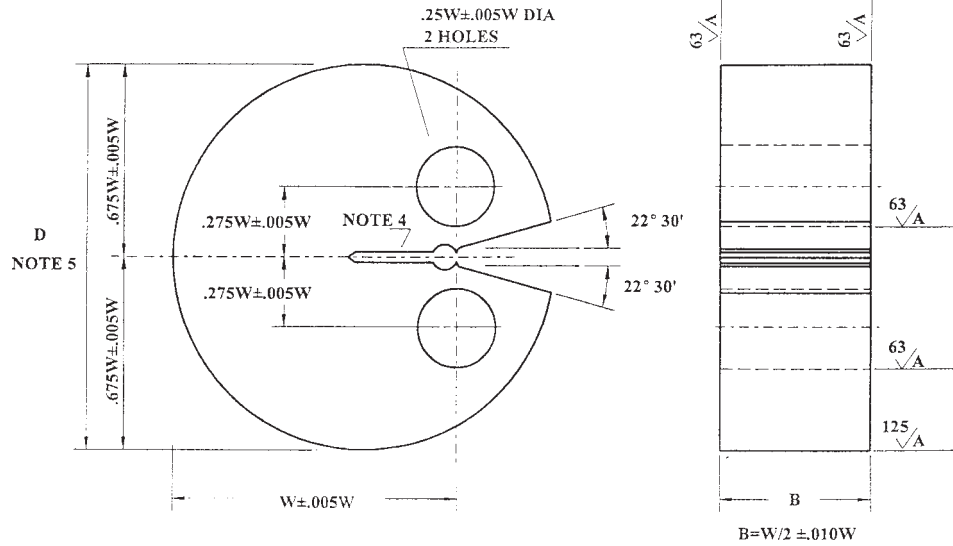

- NOTE 1—All surfaces shall be perpendicular and parallel as applicable within 0.002 W TIR.
 NOTE 2—The intersection of the crack starter notch tips on each surface of the specimen shall be equally distant within 0.005W from the centerline of the loading holes.
 NOTE 3—Integral or attached knife edges for clip gage attachment to the crack mouth may be used.
 NOTE 4—For starter-notch and fatigue-crack configuration see Fig. 6.
 NOTE 5—Required circularity measurements shall be made at eight equally spaced points around the circumference. One of these points shall be the notch plane. Average the readings to obtain the radius. All values shall be within 5 % of the average.

FIG. A3.1 Disk-Shaped Compact Specimen, DC(T), Standard Proportions and Dimensions

$$K_{(i)} = \frac{P_i}{(B B_N W)^{1/2}} f(a_i/W) \quad (A3.2)$$

where:

$$\begin{aligned} & [(2 + a_i/W)(0.76 + 4.8(a_i/W) - 11.58(a_i/W)^2) \\ & f(a_i/W) = \frac{+ 11.43(a_i/W)^3 - 4.08(a_i/W)^4}{(1 - a_i/W)^{3/2}} \end{aligned} \quad (A3.3)$$

A3.5.2 Calculation of J —For the DC(T) specimen, calculate J as follows:

$$J = J_{el} + J_{pl} \quad (A3.4)$$

where:

- J_{el} = elastic component of J , and
- J_{pl} = plastic component of J .

A3.5.2.1 J Calculation for the Basic Test Method—For the DC(T) specimen at a point corresponding to $v_{(i)}$, $P_{(i)}$ on the specimen load versus load-line displacement record calculate as follows:

$$J = \frac{K^2(1 - v^2)}{E} + J_{pl} \quad (A3.5)$$

where K is from A3.5.1 with $a = a_o$, and

$$J_{pl} = \frac{\eta A_{pl}}{B_N b_o} \quad (A3.6)$$

where:

- A_{pl} = Area A as shown in Fig. A1.2,
- B_N = net specimen thickness ($B_N = B$ if no side grooves are present),
- b_o = uncracked ligament, ($W - a_o$), and
- $\eta = 2 + 0.522b_o/W$.

A3.5.2.2 J Calculation for the Resistance Curve Test Method—For the DC(T) specimen at a point corresponding to a_p , v_i , and P_i on the specimen load versus load-line displacement record, calculate as follows:

$$J_{(i)} = \frac{(K_{(i)})^2(1 - v^2)}{E} + J_{pl(i)} \quad (A3.7)$$

where $K_{(i)}$ is from A3.5.1 and:

$$J_{pl(i)} = \left[J_{pl(i-1)} + \left(\frac{\eta_{(i-1)}}{b_{(i-1)}} \right) \frac{A_{pl(i)} - A_{pl(i-1)}}{B_N} \right] \left[1 - \gamma_{(i-1)} \frac{a_{(i)} - a_{(i-1)}}{b_{(i-1)}} \right] \quad (A3.8)$$

where:

$$\eta_{(i-1)} = 2.0 + 0.522 b_{(i-1)}/W, \text{ and}$$

$$\gamma_{(i-1)} = 1.0 + 0.76 b_{(i-1)}/W.$$

In the preceding equation, the quantity $A_{pl(i)} - A_{pl(i-1)}$ is the increment of plastic area under the load versus load-line displacement record between lines of constant displacement at points $i-1$ and i shown in Fig. A1.3. The quantity $J_{pl(i)}$ represents the total crack growth corrected plastic J at Point i and is obtained in two steps by first incrementing the existing $J_{pl(i-1)}$ and then by modifying the total accumulated result to account for the crack growth increment. Accurate evaluation of $J_{pl(i)}$ from the preceding relationship requires small and uniform crack growth increments consistent with the suggested elastic compliance spacing of Annex A8 and Annex A10. The quantity $A_{pl(i)}$ can be calculated from the following equation:

$$A_{pl(i)} = A_{pl(i-1)} + \frac{[P_{(i)} + P_{(i-1)}][v_{pl(i)} - v_{pl(i-1)}]}{2} \quad (A3.9)$$

where:

$$v_{pl(i)} = \text{plastic part of the load-line displacement, } v_i - (P_i C_{LL(i)}), \text{ and}$$

$$C_{LL(i)} = \text{compliance, } (\Delta v/\Delta P)_i \text{ required to give the current crack length, } a_i.$$

For test methods that do not utilize the elastic compliance techniques, $C_{LL(i)}$ can be determined from knowledge of $a_{(i)}/W$ using the following equation:

$$C_{LL(i)} = \frac{1}{EB_e} \left(\frac{1 + a_{(i)}/W}{1 - a_{(i)}/W} \right)^2 [2.0462 + 9.6496(a_{(i)}/W) - 13.7346(a_{(i)}/W)^2 + 6.1748(a_{(i)}/W)^3] \quad (A3.10)$$

where:

$$B_e = B - (B - B_N)^2/B.$$

In an elastic compliance test, the rotation corrected compliance, $C_c(i)$, described in A3.5.4 shall be used instead of $C_{LL(i)}$ given above.

A3.5.3 Calculation of Crack Length—For a single-specimen test method using an elastic compliance technique on DC(T) specimens with crack opening displacements measured at the load-line, the crack length is given as follows:

$$a_{(i)}/W = 0.998193 - 3.88087u + 00.187106u^2 + 20.3714u^3 - 45.2125u^4 + 44.5270u^5 \quad (A3.11)$$

where:

$$u = \frac{1}{[(B_e EC_{c(i)})^{1/2} + 1]} \quad (A3.12)$$

where:

$$C_{c(i)} = \text{specimen crack opening compliance } (\Delta v/\Delta P) \text{ on an unloading/reloading sequence, corrected for rotation (see A3.5.4),}$$

$$B_e = B - (B - B_N)^2/B.$$

A3.5.4 To account for crack opening displacement in DC(T) specimens, the crack size estimation shall be corrected for rotation. Compliance shall be corrected as follows:

$$C_{c(i)} = \frac{C_i}{\left[\frac{H^*}{R} \sin\theta_i - \cos\theta_i \right] \left[\frac{D}{R} \sin\theta_i - \cos\theta_i \right]} \quad (A3.13)$$

where (Fig. A2.3):

C_i = measured specimen elastic compliance (at the load-line),

H^* = initial half-span of the load points (center of the pin holes),

R = radius of rotation of the crack centerline, $(W + a)/2$, where a is the updated crack length,

D = one half of the initial distance between the displacement measurement points,

θ = angle of rotation of a rigid body element about the unbroken midsection line, or

$$\theta = \sin^{-1} \left[\frac{\left(\frac{d_m}{2} + D \right)}{(D^2 + R^2)^{1/2}} \right] - \tan^{-1} \left(\frac{D}{R} \right), \text{ and} \quad (A3.14)$$

d_m = total measured load-line displacement.

A3.5.5 Other compliance equations are acceptable if the resulting accuracy is equal to or greater than those described and the accuracy has been verified experimentally.

A3.5.6 *Calculation of CTOD:*

A3.5.6.1 *Calculation of CTOD for the Basic Test Method*—For the basic test method calculations of CTOD for any point on the load-displacement curve are made from the following expression:

$$\delta_{(i)} = \frac{K_{(i)}^2(1 - \nu^2)}{2\sigma_{YS}E} + \frac{[r_p(W - a_o)]v_{pl(i)}}{[r_p(W - a_o) + a_o + z]} \quad (A3.15)$$

where:

a_o = original crack length,

K = stress intensity factor as defined in A3.5.1 with $a = a_o$,

ν = Poisson's ratio,

σ_{YS} = yield or 0.2 % offset yield strength at the temperature of interest,

E = elastic modulus at the test temperature,

v_{pl} = plastic component of clip gage opening displacement at the point of evaluation on the load-displacement curve, v_c , v_u , or v_m ,

z = distance of knife edge measurement point from the load-line on the C(T) specimen, and

r_p = plastic rotation factor = 0.4 (1 + α),

where:

$$\alpha = 2 \left[\left(\frac{a_o}{b_o} \right)^2 + \frac{a_o}{b_o} + \frac{1}{2} \right]^{1/2} - 2 \left(\frac{a_o}{b_o} + \frac{1}{2} \right) \quad (A3.16)$$

A3.5.6.2 *Calculation of CTOD for the Resistance Curve Test Method*—For the resistance curve test method, calculations of CTOD for any point on the load-displacement curve are made from the following expression:

$$\delta_{(i)} = \frac{K_{(i)}^2(1 - \nu^2)}{2\sigma_{YS}E} + \frac{[r_{p(i)}(W - a_{(i)}) + \Delta a]v_{pl(i)}}{[r_{p(i)}(W - a_{(i)}) + a_{(i)} + z]} \quad (A3.17)$$

where:

$a_{(i)}$ = current crack length,

Δa = $a_{(i)} - a_o$,

$K_{(i)}$ = stress intensity factor as defined in A3.5.1, with $a = a_{(i)}$, and

$r_{p(i)}$ = plastic rotation factor = 0.4 (1 + $\alpha_{(i)}$),

where:

$$\alpha_{(i)} = 2 \left[\left(\frac{a_{(i)}}{b_{(i)}} \right)^2 + \frac{a_{(i)}}{b_{(i)}} + \frac{1}{2} \right]^{1/2} - 2 \left(\frac{a_{(i)}}{b_{(i)}} + \frac{1}{2} \right) \quad (A3.18)$$

and the other terms are defined in A3.5.6.1.

A4. METHODS FOR EVALUATING INSTABILITY AND POP-IN

NOTE A4.1—Annex A4-Annex A7 through cover methods for evaluating toughness for fracture instability.

A4.1 *Pop-In Crack Propagation:*

A4.1.1 If the pop-in is attributed to an arrested fracture instability in the plane of the fatigue precrack, the result is considered to be a characteristic of the material tested. Pop-in can be assessed by a specific change in compliance, and also a posttest examination of the fracture surfaces. Pop-ins are only evaluated when the load rises with increasing displacement after the pop-in.

A4.1.2 The following procedure may be used to assess the significance of small pop-ins when the post-test examination indicates that these are associated with arrested fracture instability in the plane of the fatigue precrack (Refer to Fig. A4.1):

A4.1.2.1 Draw a line, CB , which is parallel to the initial slope OA and that passes through the crack initiation load point of the pop-in under consideration.

A4.1.2.2 Draw a second line, that originates at Point C : Line CF , and that has 5 % reduced slope from Line CB .

A4.1.2.3 Mark the point G , corresponding to the load and displacement at pop-in crack arrest.

A4.1.2.4 When Point G is within the angle BCF , the pop-in is judged to be insignificant. (See Fig. A4.1(b).)

A4.1.2.5 When Point G is outside the angle BCF , the pop-in is significant (see Fig. A4.1(a)). J and δ values determined beyond point G are invalid. Calculate values of fracture toughness corresponding to the point of onset (v_c or v_u).

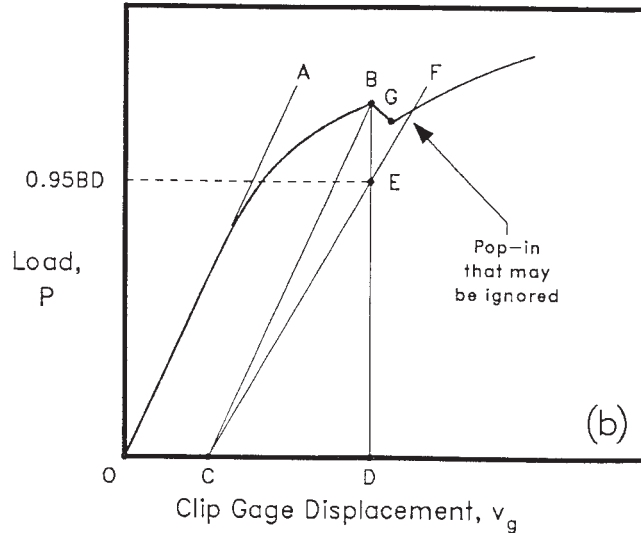
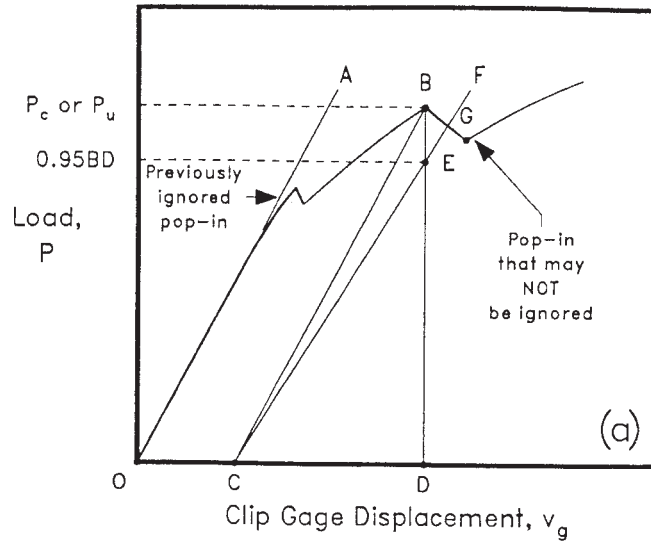

NOTE 1—Slope of Line CF is exaggerated for clarity.

FIG. A4.1 Procedure for Evaluating Significance of Pop-in

A5. METHOD FOR K_{Ic} DETERMINATION

A5.1 This annex describes the methods and calculations required to determine the linear elastic, plane-strain fracture toughness, K_{Ic} , and the associated requirements for qualifying the data according to this test method. Data meeting all of the qualification requirements of 9.1 and those of this annex result in a size-independent K_{Ic} value.

A5.2 *Test Record*—Conduct the test following the procedure in Section 8. Make a test record as shown in Fig. A5.1 with the load along the vertical axis and crack-mouth displacement along the horizontal axis. This record can be generated autographically during the test or after the test from digitally recorded data. If only an autographic record is taken, the initial slope of the linear portion on the plotter shall be between 0.7 and 1.5.

A5.3 *Calculation of Results*—In order to determine K_{Ic} in accordance with this test method, it is necessary first to calculate a conditional result, K_{Ic} , which involves a construction on the test record, and then to determine whether this result is consistent with size and yield strength requirements. The procedure is as follows:

A5.3.1 Construct a secant line as shown on Fig. A5.1 with a slope $(P/v)_5 = 0.95(P/v)_o$ where $(P/v)_o$ is the slope of the tangent

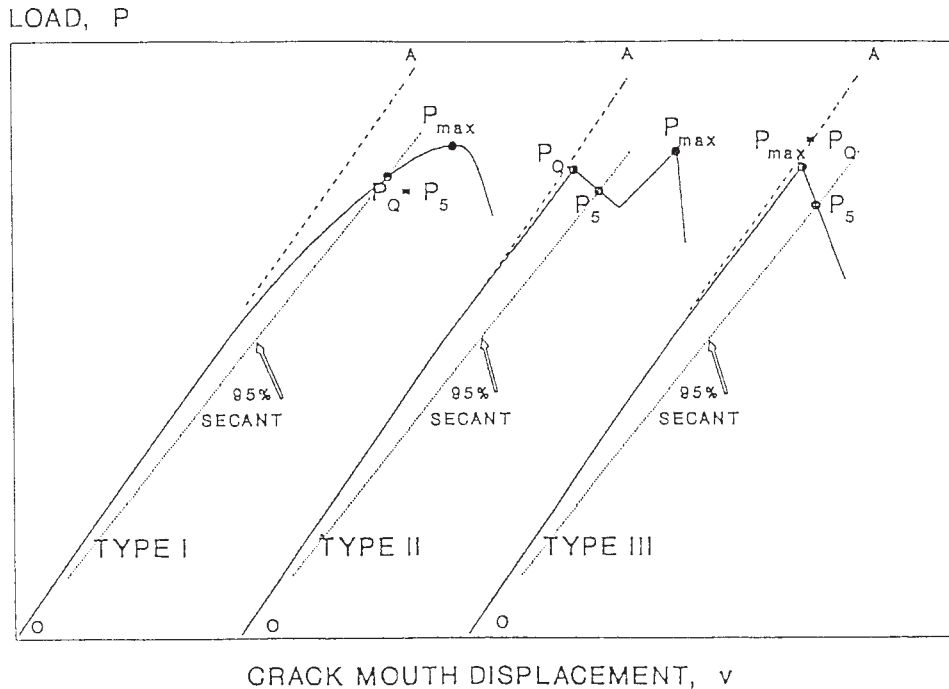

FIG. A5.1 Principle Types of Load-Displacement Records

OA to the initial portion of the data record. This slope can be obtained from a slope calculation using digital data or fit to an autographic record as desired.

NOTE A5.1—Slight nonlinearity often occurs at the very beginning of a record and should be ignored. However, it is important to establish the initial slope of the record with high precision and therefore it is advisable to minimize this nonlinearity by a preliminary loading and unloading with the maximum load not producing a stress intensity level exceeding that used in the final stage of fatigue cracking.

The load P_Q is then defined as follows: if the load at every point on the record that precedes P_5 is lower than P_5 , then P_5 is P_Q (Fig. A5.1, Type I); if, however, there is a maximum load preceding P_5 that exceeds it, then this maximum load is P_Q (Fig. A5.1, Types II and III).

NOTE A5.2—For the Annex A1-Annex A3 specimens over the range $0.45 \leq a/W \leq 0.55$, the 95 % offset criterion corresponds to an increase in elastic compliance equivalent to that caused by a crack extension of approximately 2 % of the original remaining ligament, b_o , or the original crack length, a_o .

A5.4 Qualification of K_Q as K_{Ic} :

A5.4.1 For K_Q to be qualified as a K_{Ic} value it must meet the qualification requirements of 9.1. To be a size-independent K value, it must meet the following requirements:

A5.4.2 Calculate the ratio P_{max}/P_Q , where P_{max} is the maximum load the specimen was able to sustain (see Fig. A5.1). If this ratio does not exceed 1.10, proceed to calculate K_Q as described in Annex A1-Annex A3 using the formula appropriate to the specimen being tested. If P_{max}/P_Q does exceed 1.10, then the test is not a size-independent K_{Ic} test because it is then possible that K_Q bears no relation to K_{Ic} .

A5.4.3 Calculate $2.5 (K_Q/\sigma_{YS})^2$ where σ_{YS} is the 0.2 % offset yield strength in tension (see Test Methods E 8). If this quantity is less than both the specimen thickness, B , and the length of the initial uncracked ligament, b_o , then K_Q is equal to K_{Ic} . Otherwise, the test is not a qualified and size-independent K_{Ic} test. Expressions for calculations of K_Q are given in the Annex A1-Annex A3 appropriate to the specimen being tested.

A5.4.4 If the test result fails to meet the qualification requirements in 9.1 or in A5.4, or both, it will be necessary to use a larger specimen to determine K_{Ic} . The dimensions of the larger specimen can be estimated on the basis of K_Q but generally will be at least 1.5 times those of the specimen that failed to yield a qualified and size-independent K_{Ic} value. The unqualified K_{Ic} test result can be evaluated by the methods of Annex A4-Annex A7 and Annex A8-Annex A11 to determine whether other measures of fracture toughness can be developed from this test method.

A5.5 Significance of K_{Ic} —The property K_{Ic} determined by this test method characterizes the resistance of a material to fracture in a neutral environment in the presence of a sharp crack under severe tensile constraint, such that the state of stress near the crack front approaches tritensile plane strain, and the crack-tip plastic region is small compared to both the crack size and to the specimen dimension in the constraint direction. A K_{Ic} value is believed to represent the lower limiting value of fracture toughness.

A6. FRACTURE INSTABILITY TOUGHNESS DETERMINATION USING J

A6.1 This annex describes the method for characterizing fracture toughness values based on J , J_c , or J_u , for a fracture instability and the associated requirements for qualifying the data according to this test method. Data meeting all of the qualification requirements of 9.1 and those of this annex result in qualified values of J_c or J_u . Data meeting the size requirement result in a value of J_c that is insensitive to the in-plane dimensions of the specimen.

A6.2 *Fracture Instability Before Stable Tearing*—When fracture occurs before stable tearing a single-point toughness value may be obtained labeled J_c .

A6.2.1 J is calculated at the final point, instability, using the J formulas for the basic method. (Note: These formulas must be applied for evaluating J no matter which method was used in the test because a resistance curve was not obtained.) This point is labeled J_{Qc} , a provisional J_c value.

A6.2.2 *Qualification of J_{Qc} as J_c* — $J_{Qc} = J_c$, a measure of fracture toughness at instability without significant stable crack extension that is independent of in-plane dimensions, provided the following two conditions are both met: (1) if the material is a ferritic steel and the measured room temperature yield and tensile strength fall within the box illustrated in Fig. A6.1, $B, b_o \geq 50 J_Q/\sigma_y$, otherwise $B, b_o \geq 100 J_Q/\sigma_y$, and (2) crack extension $\Delta a_p < 0.2 \text{ mm} + J_Q/M\sigma_y$ where $M = 2$, or an alternative value can be determined from the test data, see A9.8. Note that even if these conditions are met, J_c may be dependent on thickness (length of crack front).

A6.3 *Fracture Instability After Stable Tearing*—When fracture occurs after stable tearing crack extension $\Delta a_p > 0.2 \text{ mm}$ (0.008 in.) + $J_Q/M\sigma_y$, a single-point fracture toughness value may be obtained, labeled J_{Qu} . In addition, part of an R curve may be developed or the final point may be used in the evaluation of an initiation toughness value J_{Ic} (these are described in Annex A8-Annex A11).

A6.3.1 J is calculated at the final point where instability occurs using the J formulas for the basic method. These formulas must be used for evaluating a single J value no matter which method was used in the test. This point is a J_u value.

A6.3.2 *Qualification of J_{Qu} as J_u* — $J_{Qu} = J_u$ if crack extension $\Delta a_p \geq 0.2 \text{ mm}$ (0.008 in.) + $J_Q/M\sigma_y$.

A6.4 *Significance of J_c and J_u* —Values of J_{Qc} that meet the size criteria are labeled J_c and are considered to be insensitive to the in-plane dimensions of the specimen. Values of J_{Qc} that do not meet validity remain J_{Qc} and may be size-dependent. J_u is not considered to be a size-insensitive property and therefore is not subject to a size criterion. It is a characteristic of the material and specimen geometry and size. It signifies that at the test temperature the material is not completely ductile and can sustain only limited R -curve behavior.

A7. FRACTURE INSTABILITY TOUGHNESS DETERMINATION USING CTOD (δ)

A7.1 This annex describes the method for characterizing fracture toughness values based on δ , δ_c , δ_u , or δ_m , for a fracture instability and the associated requirements for qualifying the data according to this test method. Data meeting all of the qualification requirements of 9.1 and those in this annex result in qualified values of δ_c , δ_u , or δ_m . Data meeting the size requirement result in a value of δ_c that is insensitive to in-plane dimensions of the specimen.

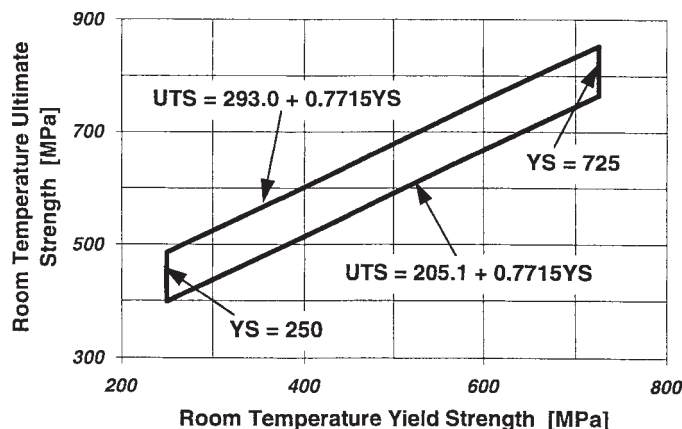

FIG. A6.1 Strength Limits Within Which Use of $M = 50$ is Justified for Ferritic Steels.

A7.2 Fracture Instability Before Stable Tearing—When fracture occurs before stable tearing a single-point toughness value may be obtained labeled δ_c .

A7.2.1 δ is calculated at the final point, instability, using the δ formulas from Annex A1-Annex A3. This point is labeled δ_{Qc} , a provisional δ_c value.

A7.2.2 Qualification of δ_{Qc} as δ_c —A fracture toughness value that is insensitive to the in-plane dimensions of the specimen, if the following two conditions are met: (1) $\delta_{Qc} = \delta_c$ if $B, b_o \geq 300 \delta_{Qc}$, and (2) crack extension $\Delta a_p < 0.2$ mm (0.008 in.) + δ_{Qu}/M_δ where $M_\delta = 1.4$ or an alternative value can be determined from the test data, see A11.3. Data that fail to meet the size criterion based on B or b_o , but still meet the restriction on crack extension, are labeled δ_c .

A7.3 Fracture Instability After Stable Tearing—When fracture occurs after stable tearing, crack extension $\Delta a_p \geq 0.2$ mm (0.008 in.) + $0.7 \delta_{Qu}$, a single-point fracture toughness value may be obtained, labeled δ_u . In addition, part of an R curve may be developed or the final point may be used in the evaluation of an initiation toughness value (these are described in Annex A8-Annex A11).

A7.3.1 δ is calculated at the final point where instability occurs, using the δ formulas for the basic method. These formulas must be used for evaluating a single δ value no matter which apparatus was used in the test. This point is labeled δ_{Qu} , a provisional δ_u value.

A7.3.2 Qualification of δ_{Qu} as δ_u — $\delta_{Qu} = \delta_u$, if crack extension, $\Delta a_p > 0.2$ mm (0.008 in.) + δ_{Qu}/M_δ where $M_\delta = 1.4$ or an alternative value can be determined from the test data, see A11.3.

A7.3.3 Significance of δ_c and δ_u —Values of δ_{Qc} that meet the qualification requirements are labeled δ_c and are considered to be insensitive to the in-plane dimensions of the specimen. Values of δ_{Qu} that do not meet the size requirement are δ_c and may be size-dependent. δ_u is not considered to be a size-insensitive property and, therefore, is not subject to a size criterion. It is a characteristic of the material and specimen geometry and size. It signifies that at the test temperature the material is not completely ductile and can sustain only limited R -curve behavior.

A7.4 Maximum Load δ_m —When no fracture instability occurs up to the first attainment of maximum load, a value of δ_m can be calculated. δ is calculated at the first attainment of maximum load plateau using the formulas for the basic method. These formulas must be used no matter which apparatus was used. δ_m may be size-dependent and a function of test specimen geometry and is not subject to a size criterion. It can be useful to define limits on ductile fracture behavior.

A8. J-R CURVE DETERMINATION

NOTE A8.1—Annex A8-Annex A11 cover methods for evaluating toughness for stable tearing.

A8.1 This method describes a single-specimen technique for determining the J - R curve of metallic materials. The J - R curve consists of a plot of J versus crack extension in the region of J controlled growth. To measure the J - R curve, the resistance curve procedure of 8.6 must be used. The J - R curve is qualified provided that the criteria of 9.1 and A8.3 are satisfied.

A8.2 J Calculation:

A8.2.1 J can be calculated at any point on the load versus load-line displacement record using the equations suggested in the calculation section of Annex A1-Annex A3 for the different specimen geometries.

A8.2.2 The values of crack length are calculated using the compliance equations described in Annex A1-Annex A3 (or an alternative method for measuring crack length). The rotation correction shall be applied to account for geometry changes due to deformation for the compact, C(T) and disk-shaped compact DC(T) specimens.

A8.2.3 The unload/reload sequences should be spaced with the displacement interval not to exceed $0.01 W$, the average being about $0.005 W$. If an initiation value of toughness is being evaluated more unload/reload sequences may be necessary in the early region of the J - R curve.

A8.3 Measurement Capacity of Specimen:

A8.3.1 The maximum J -integral capacity for a specimen is given by the smaller of the following:

$$J_{max} = b\sigma_y/20, \text{ or}$$

$$J_{max} = B\sigma_y/20.$$

A8.3.2 The maximum crack extension capacity for a specimen is given by the following:

$$\Delta a_{max} = 0.25 b_o$$

A8.4 Constructing the J - R Curve:

A8.4.1 The J -integral values and the corresponding crack extension values must be plotted as shown in Fig. A8.1. Shift the J - R curve according to the procedure described in A9.3. The J - R curve is defined as the data in a region bounded by the coordinate

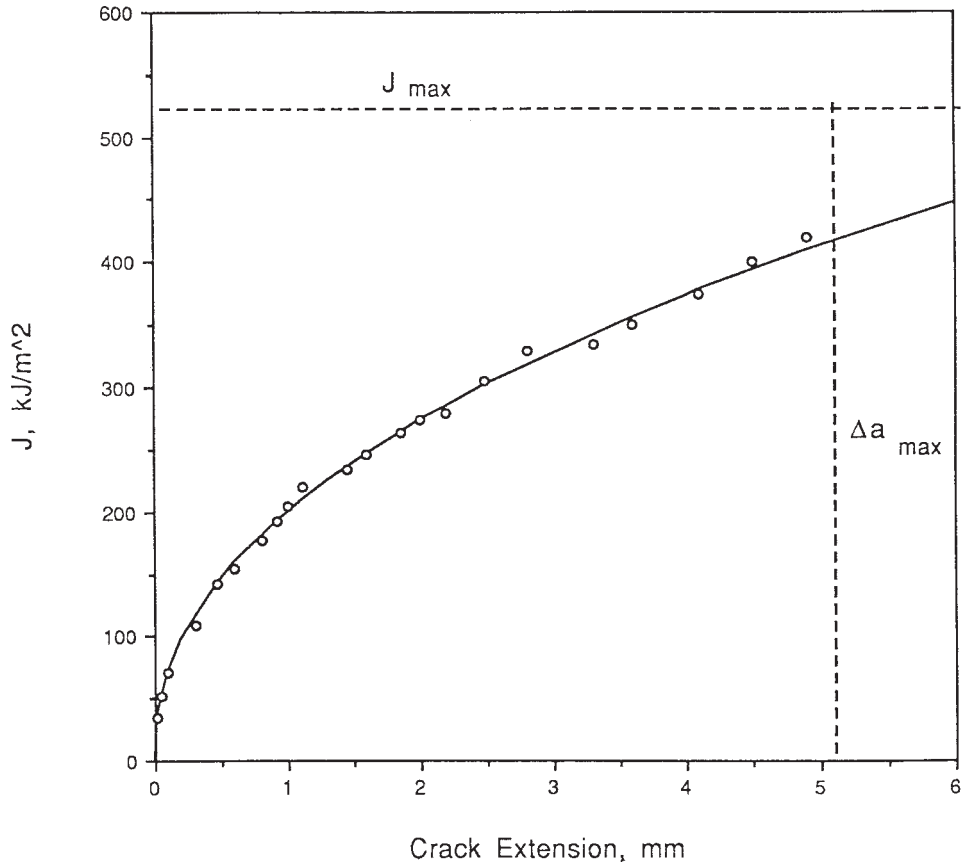

FIG. A8.1 Typical J-R Curve

axes and the J_{max} and Δa_{max} limits given in A8.3.1 and A8.3.2.

A9. J_{Ic} and K_{JIc} EVALUATION

A9.1 *Significance*—The property J_{Ic} determined by this method characterizes the toughness of a material near the onset of crack extension from a preexisting fatigue crack. The J_{Ic} value marks the beginning stage of material crack growth resistance development, the full extent of which is covered in Annex A8. J_{Ic} is qualified provided that the criteria of 9.1 and A9.8 and A9.9 are satisfied.

A9.2 *J Calculation*—Calculations of the J integral are made using the equations in Annex A1-Annex A3.

A9.3 *Corrections and Adjustments to Data:*

A9.3.1 A correction is applied to the estimated Δa_i data values to obtain an improved a_{oq} . This correction is intended to obtain the best value of a_{oq} , based on the initial set of crack length estimates, a_i , data. For data generated using the basic procedure of 8.4, no adjustments to the data are necessary. To evaluate J_{Ic} using data from the basic procedure, proceed to A9.6.

A9.3.2 A modified construction line slope, M , can be calculated from a fit to the initial J_i and a_i data, and used for the calculation of J_{Ic} .

A9.3.3 *Adjustment of a_{oq}* —The value of J_Q is very dependent on the a_{oq} used to calculate the Δa_i quantities. The value obtained for a_{oq} in 8.6.3.1 might not be the correct value and the following adjustment procedure is required.

A9.3.3.1 Identify all J_i and a_i pairs that were determined before the specimen reached the maximum load for the test. Use this data set of points to calculate a revised a_{oq} from the following equation:

$$a = a_{oq} + \frac{J}{2\sigma_y} + BJ^2 + CJ^3 \quad (A9.1)$$

The coefficients of this equation shall be found using a least squares fit procedure. An example BASIC code (see Fig. X1.1) to accomplish this fit is presented in Appendix X1.

A9.3.3.2 If the number of points used in A9.3.3.1 to determine a_{oq} is less than 8 or of these 8 there are less than 3 between 0.4

J_Q and J_Q or the correlation coefficient of this fit is less than 0.96, the data set is not adequate to evaluate any toughness measures in accordance with this test method.

A9.4 If the optically measured crack length, a_o , differs from a_{oq} by more than 0.01W, the data set is not adequate according to this test method.

A9.5 Evaluate the final J_i values using the adjusted a_{oq} of A9.3.3 and the equations of the applicable Annex A1, Annex A2, or Annex A3.

A9.6 Calculation of an Interim J_Q :

A9.6.1 *Basic Procedure*—for each specimen, calculate Δa as follows:

$$\Delta a = a_p - a_o \tag{A9.2}$$

Resistance Curve Procedure—for each a_i value, calculate a corresponding Δa_i as follows:

$$\Delta a_i = a_i - a_{0q} \tag{A9.3}$$

Plot J versus Δa as shown in Fig. A9.1. Determine a construction line in accordance with the following equation:

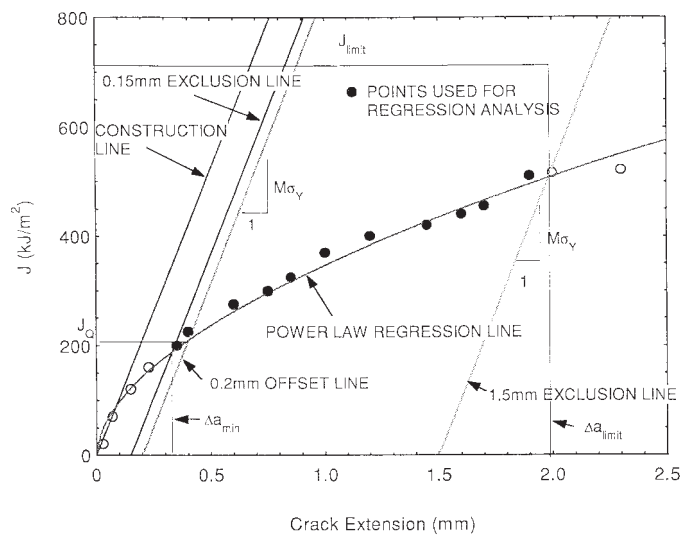

FIG. A9.1 Definition of Construction Lines for Data Qualification

$$J = M\sigma_y\Delta a \tag{A9.4}$$

where $M = 2$ or M can be determined from the test data. In some cases the initial slope of the J - R curve is steeper than $2\sigma_y$, for example with austenitic stainless steels. For these materials, it is recommended that a J_Q value be determined using $M = 2$ such that an experimental M can then be evaluated and verified according to A9.7. An improved J_Q can then be evaluated. Under no circumstances can a value of M less than 2 be used for J_Q evaluation.

A9.6.2 Plot the construction line, then draw an exclusion line parallel to the construction line intersecting the abscissa at 0.15 mm (0.006 in.). Draw a second exclusion line parallel to the construction line intersecting the abscissa at 1.5 mm (0.06 in.). Plot all $J - \Delta a$ data points that fall inside the area enclosed by these two parallel lines and capped by $J_{limit} = b_0\sigma_y/15$.

A9.6.3 Plot a line parallel to the construction and exclusion lines at an offset value of 0.2 mm (0.008 in.).

A9.6.4 At least one $J - \Delta a$ point shall lie between the 0.15-mm (0.006-in.) exclusion line and a parallel line with an offset of 0.5 mm (0.02 in.) from the construction line as shown in Fig. A9.2. At least one $J - \Delta a$ point shall lie between this 0.5-mm offset line and the 1.5-mm (0.06-in.) exclusion line. Acceptable data are shown in Fig. A9.2. The other $J - \Delta a$ pairs can be anywhere inside the exclusion zone.

A9.6.5 Using the method of least squares, determine a linear regression line of the following form:

$$\ln J = \ln C_1 + C_2 \ln \left(\frac{\Delta a}{k} \right) \tag{A9.5}$$

where $k = 1.0$ mm or 0.0394 in. Use only the data which conform to the requirements stated in the previous sections. Draw the regression line as illustrated in Fig. A9.1.

A9.6.6 The intersection of the regression line of A9.6.5 with the 0.2-mm offset line defines J_Q and Δa_Q . To determine this intersection the following procedure is recommended.

A9.6.6.1 As a starting point estimate an interim $J_{Q(1)} = J_{Q(i)}$ value from the data plot of Fig. A9.1.

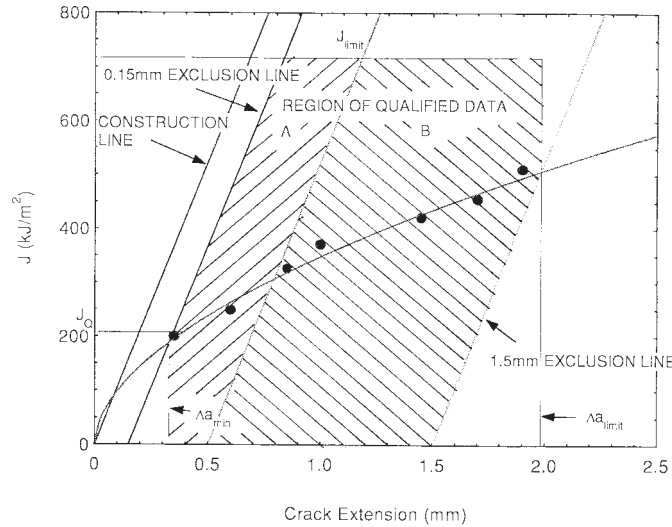

FIG. A9.2 Definition of Regions for Data Qualification

A9.6.6.2 Evaluate $\Delta a_{(i)}$ from the following:

$$\Delta a_{(i)} = \frac{J_{Q(i)}}{M\sigma_Y} + 0.2 \text{ mm (0.008 in.)} \quad (\text{A9.6})$$

A9.6.6.3 Evaluate an interim $J_{Q(i+1)}$ from the following power law relationship:

$$J_{Q(i+1)} = C_1 \left(\frac{\Delta a_{(i)}}{k} \right)^{C_2} \quad (\text{A9.7})$$

where $k = 1.0 \text{ mm}$ or 0.0394 in.

A9.6.6.4 Increment i and return to A9.6.6.2 and A9.6.6.3 to get $\Delta a_{(i)}$ and interim $J_{Q(i+1)}$ until the interim J_Q values converge to within $\pm 2\%$.

A9.6.6.5 Project the intercepts of the power law curve with the 0.15-mm (0.006-in.) and the 1.5-mm (0.06-in.) exclusion lines vertically down to the abscissa. This indicates Δa_{min} and Δa_{limit} , respectively. Eliminate all data points that do not fall between Δa_{min} and Δa_{limit} as shown in Fig. A9.1. Also eliminate all data points which lie above the limiting J capacity where $J_{limit} = b_o \sigma_Y / 15$. The region of qualified data is shown in Fig. A9.2.

A9.6.6.6 At least five data points must remain between Δa_{min} and Δa_{limit} and J_{limit} . Data point spacing must meet the requirements of A9.6.4. If these data points are different from those used in A9.6.6 to evaluate J_Q , obtain a new value of J_Q based only on qualified data.

A9.7 An alternative construction line slope, M , can be calculated by fitting the least squares linear regression line to the initial J - R curve data for data in the region $0.2 J_Q \leq J_i \leq 0.6 J_Q$ as evaluated with $M = 2$. A minimum of 6 data points are required in the evaluation region to allow an experimental value of M . Only values of $M \geq 2$ are allowed by this method. A revised J_Q can now be evaluated using this M by returning to A9.6.1-A9.6.6.

A9.8 *Qualification of Data*—The data shall satisfy the requirements of 9.1 and all of the following requirements to be qualified according to this test method. If the data do not pass these requirements no fracture toughness values can be determined according to this test method.

A9.8.1 The power coefficient C_2 of A9.6.5 shall be less than 1.0.

A9.8.2 For the *Resistance Curve Procedure* the following additional requirements must be satisfied:

~~A9.8.2.1 shall not differ from~~

A9.8.2.1 a_{oq} shall not differ from a_o by more than 0.01 W .

A9.8.2.2 The number of data available to calculate a_{oq} shall be ≥ 8 ; the number of data between $0.4 J_Q$ and J_Q shall be ≥ 3 ; and the correlation coefficient of the least squares fit of A9.3.3.1 shall be greater than 0.96.

A9.8.2.3 If an experimental value of M is determined, at least 6 data points are required in the region $0.2 J_Q \leq J_i \leq 0.6 J_Q$. Only $M \leq 2.0$ can be used in the method.

A9.9 *Qualification of J_Q as J_{Ic}* — $J_Q = J_{Ic}$, a size-independent value of fracture toughness, if:

A9.9.1 Thickness $B > 25 J_Q / \sigma_Y$,

A9.9.2 Initial ligament, $b_o > 25 J_Q / \sigma_Y$,

A9.9.3 *Regression Line Slope*—The slope of the power law regression line, dJ/da , evaluated at Δa_Q is less than σ_Y .

A9.10 Evaluation of $K_{He_{JIC}}$ —Calculate $K_{JIC} = \sqrt{(E'J_{Ic})}$ using $E' = E/(1-\nu^2)$ and the qualified J_{Ic} of A9.9.

A10. METHOD FOR δ -R CURVE DETERMINATION

A10.1 This annex describes a single-specimen technique for determining the δ -R curve of metallic materials. The δ -R curve consists of a plot of δ versus crack extension. To measure the δ -R curve the resistance curve procedure of 8.6 must be used. The δ -R curve is qualified provided that the criteria of 9.1 and A10.3 are satisfied.

A10.2 δ Calculation:

A10.2.1 The δ calculation can be evaluated at any point along the load versus load-line displacement record using the equations suggested in the calculation section of Annex A1-Annex A3 for the different specimen geometries.

A10.2.2 The values of crack length are calculated using the compliance equations described in Annex A1-Annex A3. The rotation correction shall be applied to account for geometry changes due to deformation for the compact, C(T) and disk-shaped compact DC(T) specimens.

A10.2.3 The unload/reload sequences should be spaced with the displacement interval less than 0.01 W, the average being about 0.005 W. If an initiation value of toughness is being evaluated more unload/reload sequences may be necessary in the early region of the δ -R Curve.

A10.3 Measurement Capacity of a Specimen:

A10.3.1 The maximum δ capacity for a specimen is given as follows:

$$\delta_{max} = b_o/20$$

A10.3.2 The maximum crack extension capacity for a specimen is given as follows:

$$\Delta a_{max} = 0.25 b_o.$$

A10.4 Constructing the δ -R Curve:

A10.4.1 The δ values and the corresponding crack extension values must be plotted as shown in Fig. A10.1. A δ -R curve is established by smoothly fitting the data points in the region bounded by the coordinate axes and the δ_{max} and Δa_{max} limits.

A11. METHOD FOR δ_{Ic} DETERMINATION

A11.1 Significance—The value of CTOD, δ_{Ic} , determined by this method characterizes the fracture toughness of materials near the onset of stable crack extension from a preexisting fatigue crack. δ_{Ic} is qualified provided that the criteria of 9.1 and A11.8 and A11.9 are satisfied.

A11.2 δ Calculation—Calculations of δ are made using the equations in Annex A1-Annex A3.

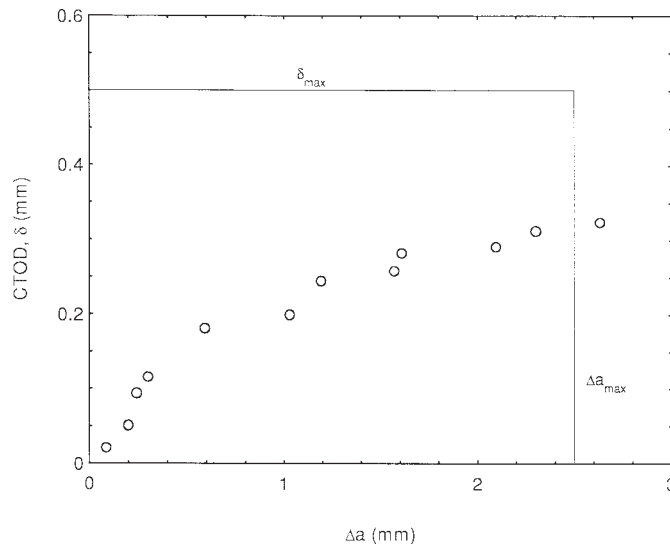

FIG. A10.1 Typical δ -R Curve

A11.6.2 Plot the construction line on suitable graph paper. Draw an exclusion line parallel to the construction line intersecting the abscissa at 0.15 mm (0.006 in.) as shown in Fig. A11.1. Draw a second exclusion line intersecting the abscissa at 1.5-mm (0.06-in.). Plot all δ - Δa_p data points that fall inside the area enclosed by these two parallel lines and capped by $\delta_{limit} = b_o/15$.

A11.6.3 One δ - Δa_p point must lie between the 0.15-mm (0.006-in.) exclusion line and a parallel line with an offset of 0.5 mm (0.02 in.) from the construction line. One δ - Δa_p point must lie between a line parallel to the construction line at an offset of 0.5 mm (0.020 in.) and the 1.5-mm exclusion line. Acceptable data is shown in Fig. A11.2 with one point in Zone A and one point in

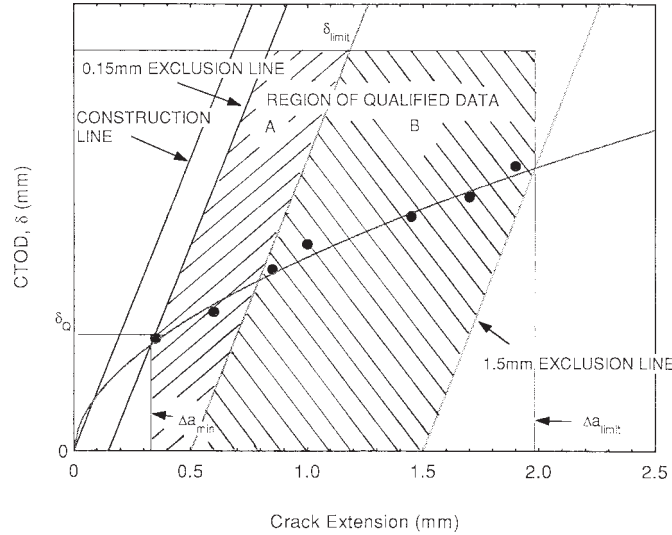

FIG. A11.2 Definition of Regions for Data Qualification

in Zone B. The other δ - Δa_p pairs can be placed anywhere inside the exclusion zone.

A11.6.4 Plot a line parallel to the construction line and exclusion lines at an offset value of 0.2 mm (0.008 in.).

A11.6.5 To establish a crack initiation measurement point under dominant slow-stable crack growth, a power law curve fitting procedure shall be used. This has the following form:

$$\delta_Q = C_1 \left(\frac{\Delta a}{k} \right)^{C_2} \tag{A11.5}$$

where $k = 1$ mm (or 0.0394 in.) depending upon units used. This power law can be determined by using a method of least squares to determine a linear regression line of the following form:

$$\ln \delta = \ln C_1 + C_2 \ln \left(\frac{\Delta a}{k} \right) \tag{A11.6}$$

Use only the data that conform to the criteria stated in the previous sections. Plot the regression line as illustrated in Fig. A11.1.

A11.6.6 The intersection of the regression line of A11.6.4 with the offset line of A11.6.5 defines δ_Q and Δa_Q . To determine this intersection the following procedure is recommended:

A11.6.6.1 Estimate a $\delta_{Q(1)}$ value from the data plot of Fig. A11.1.

A11.6.6.2 Evaluate $\Delta a_{p(1)}$ from the following:

$$\Delta a_{p(1)} = \frac{\delta_{Q(1)}}{M_\delta} + 0.2 \text{ mm (0.008 in.)} \tag{A11.7}$$

A11.6.6.3 Evaluate

$$\delta_{Q(1)} = C_1 \left(\frac{\Delta a_{p(1)}}{k} \right)^{C_2} \tag{A11.8}$$

A11.6.6.4 Return to A11.6.6.2 and A11.6.6.3 to get $\Delta a_{(i)}$ and $\delta_{Q(i+1)}$ until the δ_Q values converge to within 2 %.

A11.6.6.5 Project the intercepts of the power law curve with the 0.15-mm (0.006-in.) and the 1.5-mm (0.06-in.) exclusion lines vertically down to the abscissa. This indicates Δa_{min} and Δa_{limit} , respectively. Eliminate all data points that do not fall between Δa_{min} and Δa_{limit} as shown in Fig. A11.1. Also eliminate all data points which lie above the limiting δ capacity where $\delta_{limit} = b_o/15$. The region of qualified data is shown in Fig. A11.2.

A11.6.6.6 At least five data points must remain between Δa_{min} and Δa_{limit} and δ_{limit} . Data point spacing must meet the requirements of A11.6.3. If these data points are different from those used in A11.6.6 to evaluate δ_Q , obtain a new value of δ_Q based only on qualified data.

A11.7 An alternative construction line slope, M_δ , can be calculated by fitting the least squares linear regression line to the initial J-R curve data for data in the region $0.2\delta_Q \leq \delta_i \leq 0.6\delta_Q$ as evaluated with $M_\delta = 1.4$. A minimum of 6 data points are required in

the evaluation region to allow an experimental value of M_δ . Only values of $M_\delta \geq 1.4$ are allowed by this method. A revised δ_Q can now be evaluated using this M_δ by returning to A11.6.1-A11.6.6.

A11.8 *Qualification of Data*—The data shall satisfy the requirements of 9.1 and all of the following requirements to be qualified according to this method. If the data do not pass these requirements, no fracture toughness values can be determined according to this method.

A11.8.1 The power coefficient C_2 of A11.6.5 shall be less than 1.0.

A11.8.2 For the *Resistance Curve Procedure* the following additional requirements must be satisfied:

A11.8.2.1 a_{oq} shall not differ from a_o by more than 0.01 W .

A11.8.2.2 The number of data available to calculate a_{oq} shall be ≥ 8 ; the number of data between $0.4\delta_Q$ and δ_Q shall be ≥ 3 ; and the correlation coefficient of the least squares fit of A11.6.5 shall be greater than 0.96.

A11.8.2.3 If an experimental value of M_δ is determined, at least 6 data points are required in the region $0.2\delta_Q \leq \delta_i \leq 0.6\delta_Q$. Only $M_\delta \leq 1.4$ can be used by this method.

A11.9 *Qualification of δ_Q as δ_{Ic}* —

$\delta_Q = \delta_{Ic}$, a size-independent value of fracture toughness, if:

A11.9.1 The initial ligament, $b_o \geq 35\delta_Q$.

A11.9.2 The slope of the power law regression line, $d\delta/da$, evaluated at Δa_Q must be less than 1.

A12. COMMON EXPRESSIONS

NOTE A12.1—Annex A12 and Annex A13 cover miscellaneous information.

TABLE A12.1 Parameters for Stress-Intensity Factors

	Specimens		
	SE(B)	C(T)	DC(T)
ξ	$3(S/W) (a/W)^{1/2}$	$2 + a/W$	$2 + a/W$
ζ	$2(1 + 2a/W) (1 - a/W)^{3/2}$	$(1 - a/W)^{3/2}$	$(1 - a/W)^{3/2}$
C_0	1.99	0.886	0.76
C_1	-2.15	4.64	4.8
C_2	6.08	-13.32	-11.58
C_3	-6.63	14.72	11.43
C_4	2.7	-5.6	-4.08
Limits	$0 \leq a/W \leq 1$ $S/W = 4$	$0.2 \leq a/W \leq 1$ $H/W = 0.6$	$0.2 \leq a/W \leq 1$ $D/W = 1.35$
Refs	(10)	(10), (11)	(12)

TABLE A12.2 Parameters for Compliance Expressions

Specimen	SE(B)	C(T)	DC(T)
Location	v_{LL}	v_{LL}	v_{LL}
Y	$\frac{S}{(W-a)}$	$\frac{(W+a)}{(W-a)}$	$\frac{(W+a)}{(W-a)}$
A_0	1.193	2.163	2.0462
A_1	-1.980	12.219	9.6496
A_2	4.478	-20.065	-13.7346
A_3	-4.433	-0.9925	6.1748
A_4	1.739	20.609	0
A_5	0	-9.9314	0
Limits	$0 \leq a/W \leq 1$	$0.2 \leq a/W \leq 0.975$	$0.2 \leq a/W \leq 0.8$
Refs	(13)	(14)	(15)

A12.1 *Stress-Intensity Factor*:

A12.1.1 The elastic stress intensity factor for a specimen is expressed as follows:

$$K = \frac{Pf(a/W)}{(BB_N W)^{1/2}} \quad (\text{A12.1})$$

where:

$$f(a/W) = \left(\frac{\xi}{\xi_0}\right) [C_0 + C_1(a/W) + C_2(a/W)^2 + C_3(a/W)^3 + C_4(a/W)^4]$$

A12.1.2 The parameters for $f(a/W)$ are listed in Table A12.1.

A12.2 Compliance from Crack Length:

A12.2.1 Compliance, C , of a specimen is expressed as a function of crack length as follows:

$$C = \frac{v}{P} = \frac{Y^2}{B_e E'} [A_0 + A_1(a/W) + A_2(a/W)^2 + A_3(a/W)^3 + A_4(a/W)^4 + A_5(a/W)^5] \quad (\text{A12.2})$$

A12.2.2 $B_e = B - (B - B_N)^2/B$ and $E' = E/(1 - \nu^2)$ for all cases and the other parameters for compliance are listed in Table A12.2.

A13. METHOD FOR RAPID LOADING K_{Ic} DETERMINATION

A13.1 This annex describes the determination of plane-strain fracture toughness (K_{Ic}) properties of metallic materials under conditions where the loading rates exceed those for conventional (static) testing [150 000 psi-in.^{1/2}/min (2.75 MPa-m^{1/2}/s)].

A13.2 *Summary of Requirements*—Special requirements are necessary for plane-strain fracture toughness testing at loading rates exceeding those of conventional (static) plane-strain fracture toughness testing. This description of these requirements does not include impact or quasi-impact testing (free-falling or swinging masses). Conventional fracture toughness test specimens are prepared as described in this method, tested under rapid-load conditions, and a fracture toughness value is calculated. Load-deflection, load-time, and deflection-time curves are recorded for each test. The load-deflection curves resulting from these tests are analyzed to ensure that the initial linear portion of the load-displacement record is sufficiently well-defined that P_Q can be determined unambiguously. In addition, a test time (t), restricted to not less than one millisecond is determined. This test time and an optionally calculated average stress intensity factor rate, \dot{K} , characterize the rapid load test. The yield strength of the material must be determined or estimated for the loading time of the fracture test and is used in the analysis of the fracture test data. All of the criteria for static K_{Ic} determination apply to the rapid-load plane-strain fracture toughness test. The toughness property is denoted by $K_{Ic}(\cdot)$ where the time to reach the load corresponding to K_Q in milliseconds is indicated in the parentheses (\cdot).

A13.3 *Significance and Use*—The significance of the conventional (static) K_{Ic} properties applies also to the case of rapid loading. The plane-strain fracture toughness of certain materials is sensitive to the loading rate and substantial decreases in toughness may be noted as the loading rate increases. Generally, such materials also show a pronounced dependence of K_{Ic} on test temperature. For example, the loading rate sensitivity of structural grade steels has required the development of a lower bound K_{IR} curve, given in Appendix G of Division III of the ASME Boiler and Pressure Vessel Code,⁵ for the fracture-safe design of heavy-wall nuclear pressure vessels. Additionally, K_{Ic} values for steels tested at various temperatures and loading rates are required for correlation with small-scale production control tests (such as the Charpy V-notch test) for setting material specifications and fracture-safe design procedures.

A13.4 Apparatus:

A13.4.1 *Loading*—Generally, hydraulic machines with rapid-acting servo controlled valves are used. Depending on the compliance of the loading system and the pump capacity, an accumulator may be required.

A13.4.2 *Fixtures*—The fixtures used for static plane-strain fracture toughness tests are generally suitable for rapid-load tests. However, consideration should be given to the possibility that the toughness of the fixture material may be reduced by rapid loading.

A13.4.3 *Load and Displacement Transducers*—The transducers used for static plane-strain fracture toughness tests are generally suitable for rapid-load tests. However, these transducers must have response characteristics that will ensure that inertial effects will not influence the load and displacement signals.

NOTE A13.1—While not required, the resonant frequencies of these transducers may be determined by suitably exciting them and observing the wave characteristic on an oscilloscope. If ringing (high-frequency oscillation) is observed within the time period required to reach the P_Q load, the stiffness of the transducers should be increased or their mass reduced. Load cells are quite stiff and should provide no problem at the minimum loading time of

⁵ Available from the American Society of Mechanical Engineers, 345 E. 47th Street, New York, NY 10017.

1 ms. The displacement transducer might be cause for concern depending on its design. The cantilever beam displacement gage described in Section 6 has been used successfully at loading times slightly lower than 1 ms. The resonant frequency of this gage when mounted in a specimen in a conventional manner and excited by tapping is about 3300 Hz. The free-arm resonant frequency is about 750 Hz. Other gages of the same type but having different dimensions should operate satisfactorily if their free-arm resonance is at least 750 Hz. The following equation may be used to estimate the free-arm resonant frequency of such a gage:

$$f = RC \left[\frac{B^2 E g}{\rho l^4} \right] \quad (\text{A13.1})$$

where:

RC = 51.7,

f = resonant frequency, Hz,

B = arm thickness, m,

E = elastic modulus of the arms, MPa,

g = gravitational acceleration, 9.804 m/s²,

ρ = density of the arm material, kg/m³, and

l = length of the uniform thickness section of the arms, m.

The coefficient RC becomes 0.162 if inch-pound units are used where B is in inches, E is in pound-force per square inch, g is 386 in./s², ρ is pounds per cubic inch, and l is in inches.

A13.4.4 Signal Conditioners—Amplification or filtering of the transducer signals may be necessary. Such signal conditioning units should have a frequency response from dc to at least 20/ t (kilohertz) where t is the test time in milliseconds as defined in A13.6.3. As described in A13.4.3, conventional mechanical recording devices may not have sufficient frequency response to permit direct plotting of the load versus time and the displacement versus time signals.

A13.5 Procedure:

A13.5.1 Loading Rate—The rate of loading is optional with the investigator, but the time to reach the load corresponding to K_Q shall not be less than 1 ms. Use a preload to eliminate ringing in the load or displacement transducers associated with clearances in the load train being suddenly taken up by the start of rapid loading.

A13.5.2 For each test conducted, a load versus time, a displacement versus time, and a load versus displacement record shall be obtained. The time scale of these records shall be accurately determined since the time is used to characterize the test. Examine the time-dependent records for the presence of ringing before reaching the P_Q load. Such ringing can result from inertial effects as described in Note A13.2. The special record analysis procedure described in A13.6 may be helpful in assessing the magnitude of such effects.

NOTE A13.2—It should be recognized that some materials may exhibit a burst of crack extension at loads less than P_Q that is sufficiently abrupt to produce ringing in the displacement transducer signal. Such an abrupt advance of the crack may be associated with material inhomogeneities local to the fatigue crack tip. If the ringing is severe it may not be possible to unambiguously determine a value for P_Q . The presence of such bursts of crack extension should be recorded for those tests having analyzable load versus displacement records.

NOTE A13.3—The test data may be directly recorded if the recording devices have sufficient frequency response. Generally, it is advantageous to use a storage device that will capture the data and permit playing it out at a sufficiently slow speed that a pen recorder can be used in producing the required records. Such storage devices are commonly available in the form of digital storage oscilloscopes having pen recorder outputs. Separate storage instruments are also available. In general these digital storage devices have performance characteristics that are more than adequate to capture, store, and replay the transducer signals from a 1-ms test. For example, calculations show that for a typical fracture test, the crack-mouth displacement resolution would be about 0.76 mm/sample (0.030 mil/sample) and the load resolution would be about 712 N/sample (160 lbf/sample). It should be possible to obtain at least 1000 simultaneous samples of load and displacement during such a test. A digital storage scope capable of at least this performance would have the following characteristics: maximum digitizing rate of 1 MHz, maximum sensitivity of ± 100 mV, resolution of 0.025 %, and memory of 4096 words by 12 bits. It may be necessary to amplify the output of the clip gage moderately and possibly that of the load cell depending on its capacity in terms of the range required. These values of resolution are based on a total noise figure of about 50 mV.

A13.6 Calculation and Interpretation of Results:

A13.6.1 Special requirements are placed on the analysis of the load versus displacement record. These take into account the fact that experience (17) has shown load versus displacement records from rapid-load fracture toughness tests are not always as smooth in the linear range as those obtained from static tests. The special requirements of this annex are designed to ensure that an unambiguous value of P_Q can be determined. The test time must be determined from the load versus time record.

A13.6.2 The additional analysis of the load versus displacement record is illustrated in Fig. A13.1. The procedure is as follows: Construct the straight line OA best representing the initial portion of the test record that ideally should be linear but may not be smooth. Then construct the line OP_5 as described in Annex A5 and determine P_Q . Draw a vertical line at v_p passing through P_Q and define P_v at the point of intersection of this line with the line OA . Determine 5 % of P_v and construct two lines BC and DE parallel to OA with BC passing through $P_v + 0.05 P_v$ and DE passing through $P_Q (P_v - 0.05 P_v)$. Draw a horizontal line at $P = 0.5 P_Q$. For the test to be valid that recorded load versus displacement curve up to P_Q must lie within the envelope described by these parallel lines for the portion of the record with $P \leq 0.5 P_Q$.

A13.6.3 The test time t in milliseconds is determined from the record of load versus time as indicated in Fig. A13.2. Construct the best straight line OA through the most linear portion of the record. The value t is then determined from the point of intersection

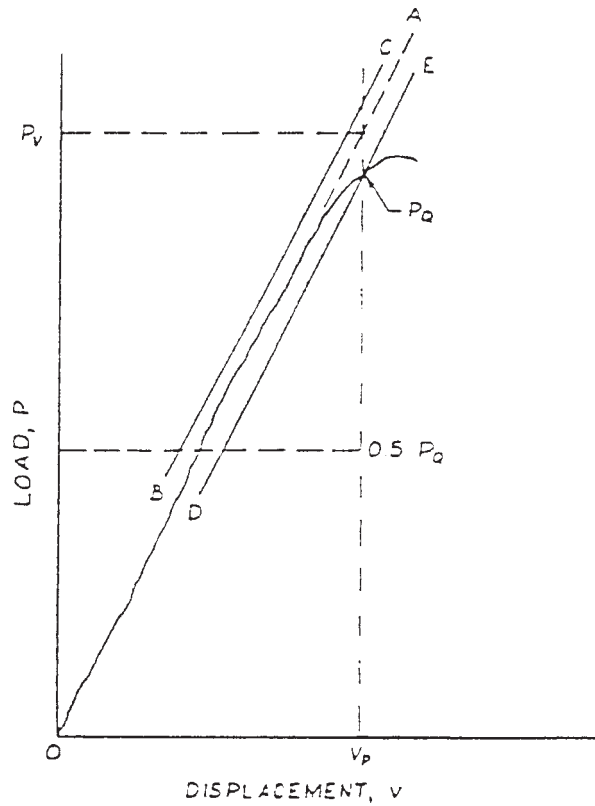

FIG. A13.1 Special Requirements for Analysis of Load Versus Displacement Records (5 % Secant Line Not Shown)

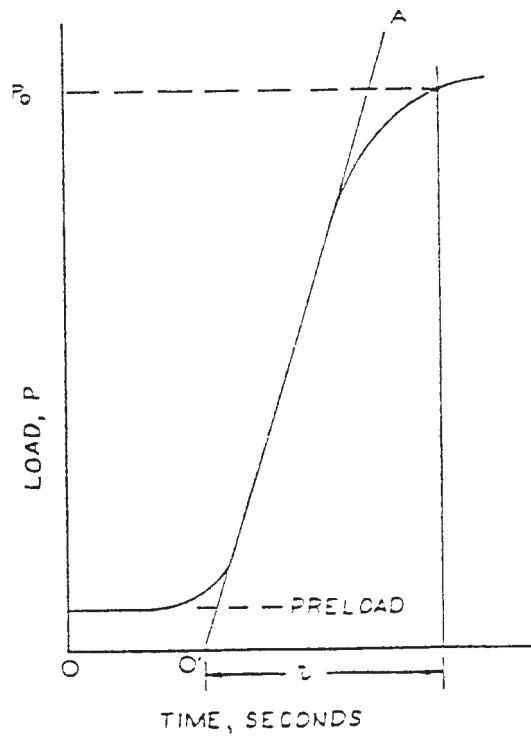

FIG. A13.2 Determination of Test Time from Load Versus Time Record

of this line with the time axis to the time corresponding to P_Q . This time, t is shown in the parentheses () following K_{Ic} . An average stress intensity rate, \dot{K} , may be calculated by dividing K_Q or K_{Ic} by t with the result being expressed in $\text{ksi}\cdot\text{in.}^{1/2}/\text{s}$ or $\text{MPa}\cdot\text{m}^{1/2}/\text{s}$. It should be recognized that minor errors in determining the loading time are not significant because significant changes in the

toughness require a change of several orders of magnitude in loading rate.

A13.6.4 The 0.2 % offset tensile yield strength σ_{YS} is used in determining the specimen size requirements for a valid test as described in Annex A5. If the rapid load value of K_Q is valid using a static yield strength value determined at a temperature at or above that of the rapid-load test, no further yield strength considerations are necessary.

A13.6.5 If the test is invalid using such a yield strength, a tension test should be conducted on the test material at the temperature and loading time of the rapid-load toughness test with the time to reach the yield load in the tension test approximately equal to the time t defined in A13.6.3.

A13.6.6 In the absence of σ_{YS} values as defined in A13.6.5, the dynamic yield strength σ_{YD} of certain steels may be estimated using the following equation:

$$\sigma_{YD} = \sigma_{YS} + \frac{A}{T_x \log_{10}(2 \times 10^7 t)} - B \quad (\text{A13.2})$$

where:

σ_{YS} = 0.2 % offset room temperature static yield strength,

t = loading time, ms, and

T_x = temperature of the rapid-load toughness test.

Units:

If σ_{YS} is in megapascals, then $A = 1\,198\,860$, $B = 187.4$ MPa,

If σ_{YS} is in pound force per square inch, then

$A = 174\,000$, $B = 27.2$ ksi,

If the test temperature T is measured in K , then $T_x = 1.8 T$, and

If the test temperature T is measured in $^{\circ}F$, then $T_x = (T + 460)$.

NOTE A13.4—The equation in A13.6.6 has been found useful only in estimating the low-temperature dynamic yield strength of constructional steels having room temperature yield strengths below 480 MPa (70 ksi).

A14. SPECIAL REQUIREMENTS FOR RAPID-LOAD J -INTEGRAL FRACTURE TOUGHNESS TESTING⁶

A14.1 Scope

A14.1.1 This annex covers the determination of the rate dependent $J_{Ic}(t)$ and the J -integral versus crack growth resistance curve (J - $R(t)$ curve) for metallic materials under conditions where the loading rate exceeds that allowed for conventional (static) testing, see Section 8.4.2.

A14.2 Summary of Requirements

A14.2.1 Special requirements are necessary for J -integral fracture toughness testing of metallic materials at loading rates exceeding those of conventional (static) testing. Standard fracture toughness test specimens are prepared as described in this method, tested under rapid-load or drop weight conditions, and a J - $R(t)$ curve is calculated. From this J - $R(t)$ curve a $J_Q(t)$ can be evaluated using Section 9 of this method. If unstable fracture intervenes, a $J_{Qc}(t)$ can be evaluated at the onset of unstable behavior as in the static case.

A14.2.1.1 Load, load line displacement, and time are recorded for each test. The load versus displacement curve resulting from each test is analyzed to ensure that the initial portion of the curve is sufficiently well defined that an unambiguous curve can be determined from the $J(t)$ versus crack length ($a(t)$) data. In addition a minimum test time is calculated from the specimen stiffness and effective mass that sets a maximum allowed test rate for the material and geometry being tested. At times less than the minimum test time a significant kinetic energy component is present in the specimen relative to the internal energy, and the static J integral equations presented in this method are not accurate. Evaluation of a $J_Q(t)$ or $J_{Qc}(t)$ at a time less than the minimum test time is not allowed by this method.

A14.2.1.2 Evaluation of the J - $R(t)$ curve requires estimation of crack extension as a function of load line displacement or time using the normalization method of Annex A15. An elastic compliance method cannot be used. A multiple specimen method can be used to evaluate $J_Q(t)$ from a series of tests, but the resulting J - $R(t)$ curve is not valid according to this method.

A14.2.1.3 All of the criteria for the static J_{Ic} , J_{cs} , and J - R curve evaluations apply to the rapid load J integral fracture toughness test. The rapid load J integral resistance curve is denoted J - $R(t)$, the stable initiation property $J_{Ic}(t)$, and the unstable initiation property by $J_{Ic}(t)$, where the time to reach the instant corresponding to J_Q in milliseconds is indicated in the brackets.

A14.3. Terminology

A14.3.1 Definitions:

⁶ This test method is an Annex to ASTM E1820. It is under the jurisdiction of ASTM Committee E08 on Fatigue and Fracture and is the direct responsibility of Subcommittee E08.08 on Elastic-Plastic and Fracture Mechanics Technology.

A14.3.1.1 The definitions given in Terminology E 1823 are applicable to this annex.

A14.3.1.2 The definitions given in Section 3 of this method are applicable.

A14.3.1.3 Rapid load—In J integral fracture testing, any loading rate such that the time taken to reach P_f (see 7.4.4) is less than 0.1 minutes.

A14.3.1.4 Minimum test time- $t_w(t)$ —In J integral fracture testing, the minimum time to the rate dependent $J_Q(t)$ or $J_{Qc}(t)$ accepted by this method (18). Test times less than t_w will lead to inaccurate J integral results since large kinetic energy components will be present. In this method:

$$t_w = \frac{2\pi}{\sqrt{k_s/M_{eff}}} \quad (\text{A14.1})$$

where:

k_s = specimen load line stiffness, (N/m),

M_{eff} = effective mass of the specimen, taken here to be half of the specimen mass (kg).

A14.3.1.5 Test time - $t_Q(t)(T)$ —In J integral fracture testing, the observed time to the rate dependent $J_Q(t)$.

A14.3.1.6 $J_c(t)(FL^{-1})$ —In J integral fracture testing, the rate dependent J integral at the onset of fracture instability prior to the onset of significant stable tearing crack extension, see Section 3.2.10, as defined in this annex.

A14.3.1.7 $J_{Qc}(t)(FL^{-1})$ —In J integral fracture testing, the provisional rate dependent J integral at the onset of fracture instability prior to the onset of significant stable tearing crack extension, as defined in this annex.

A14.3.1.8 $J_u(t)(FL^{-1})$ —In J integral testing, the rate dependent J integral at the onset of fracture instability after significant stable tearing crack extension, see Section 3.2.11, as defined in this annex.

A14.3.1.9 $J_{Ic}(t)(FL^{-1})$ —In J integral testing, the rate dependent J integral at the onset of stable crack extension as defined in this annex.

A14.3.1.10 $J_Q(t)(FL^{-1})$ —In J integral fracture toughness testing, the provisional, rate dependent, J integral at the onset of stable crack extension as defined in this annex.

A14.3.1.11 $dJ/dt(FL^{-1}T^{-1})$ —In J integral fracture testing, the rate of change of the J integral per unit time. Two loading rate quantities are defined in this method, $(dJ/dt)_I$ measured before $J_Q(t)$, and $(dJ/dt)_T$ measured after $J_Q(t)$, as defined by this annex.

A14.4 Significance and Use

A14.4.1 The significance of the static J - R curve, J_{Ic} , and J_c properties applies also to the case of rapid loading. The J integral fracture toughness of certain metallic materials is sensitive to the loading rate and to the temperature of test. The J - $R(t)$ curve and $J_{Ic}(t)$ properties are usually elevated by higher test rates while $J_c(t)$ can be dramatically lowered by higher test rates.

A14.5 Apparatus

A14.5.1 Loading—Two types of high rate loading systems are anticipated. Servohydraulic machines with high flow rate servovalves and high capacity accumulators, or alternatively, drop weight impact machines can be used. On-specimen load measurements are recommended for high rate tests. Remote load cells or other transducers can be used for high rate tests if the requirements of this annex are met. Strain gage bridges are recommended for on-specimen load measurement, as shown in Fig. A14.1 and Fig. A14.2. For each specimen type, four gages are connected to construct a four-arm bridge and calibrated statically before the rapid load test (see A14.5.4). Strain gages with grid patterns of approximately 0.25 B are recommended. For SE(B) specimens, gages should be positioned on the specimen mid-plane at the specimen span quarterpoints. For C(T) specimens, the gages should be positioned on the specimen upper and lower surfaces near the specimen mid-plane with the gage edge at least 0.1W behind the initial crack, a_o .

A14.5.2 Servohydraulic Testing Fixtures—The fixtures used for static fracture toughness tests generally require some modification for rapid load tests. Slack grip fixtures are often necessary to reduce the applied load oscillation and to allow the actuator to accelerate before load is applied to the specimen. Soft metal absorbers are generally used in drop tower tests to reduce the inertial shock caused by the impact of the test machine striker on the specimen surface.

Both initial and final crack lengths are required by the normalization method of J - $R(t)$ curve development of Annex A15. The high rate test must be stopped abruptly to obtain a limited specimen deformation and a crack extension increment satisfying the requirement of A15.1.2.1. Rigid stop block fixtures can be used to obtain the abrupt stop. In some cases a ramp and hold or square wave command signal can be used to obtain limited specimen deformation for the specimen test.

A14.5.3 Drop Tower Testing Fixtures—Special fixtures are necessary for drop tower testing according to this standard. Recommended fixtures for SE(B) and C(T) specimens are shown in Figs. A14.3 and A14.4 respectively (19). Stop block fixtures are required to obtain a limited extent of stable crack growth for J - $R(t)$ curve development. Soft metal absorbers are recommended to reduce the initial shock resulting from the impact of the drop tower striker on the specimen surface. A high frequency load line displacement transducer and signal conditioner is required for drop tower tests.

A14.5.4 Load Transducers—If remote load transducers are used, they shall meet the requirements of Practice E 4. Requirements on the measured initial specimen stiffness and on the load and displacement signal smoothness are presented in A14.7.4. Static calibration of the on-specimen strain gage bridge should be done over a load range from 20 to 100 % of the final precracking load. At least five load calibration values shall be used, spaced evenly over this interval, and at least two repeat data

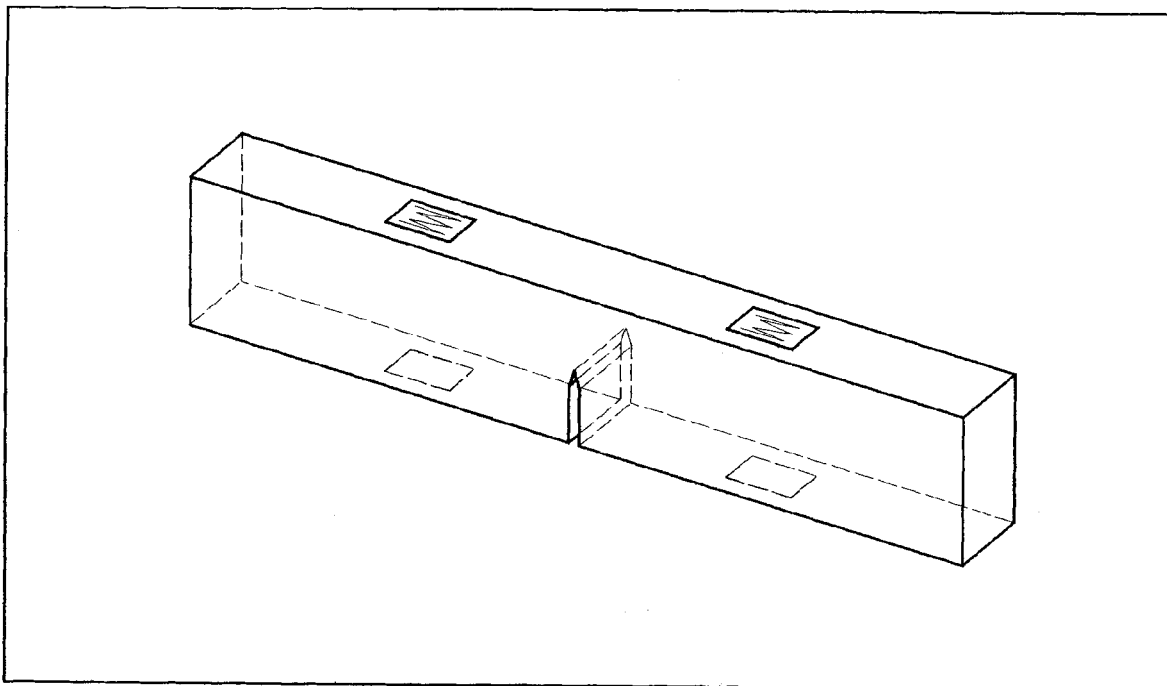

FIG. A14.1 Strain Gages Mounted on SE(B) Specimen for Measurement of Transmitted Load

sets are required. The applied load shall exceed $\frac{1}{4}$ of the calibrated range of the reference load cell used. The on-specimen, transmitted load measuring system shall be accurate to within 2 % of the final precracking load over the calibration range.

A14.5.5 Displacement Transducers—The transducer shall have response characteristics that allow it to follow the motion of the specimen while not introducing excessive mechanical noise into the measured displacement.

A14.5.5.1 Cantilever beam displacement gages such as those used in static fracture toughness testing may be suitable for rapid-load testing, see A13.4.3. The cantilever beam displacement gage described in Annex A1 of Test Method E 399 has been used successfully at loading times (t_Q) slightly less than 1 ms.

A14.5.5.2 Gap measuring transducers that use either capacitance or optical means to measure displacement have also been used successfully in rapid-load testing (19). These transducers have the advantage that they can be rigidly attached to the specimen, and the vibration characteristics of the transducer generally do not affect the measured displacement. The disadvantages are that the output may be non-linear, and the signal conditioners used with these transducers are often the limiting component in frequency response of the displacement measurement system. Capacitive transducers have been designed to fit in the notch of the C(T) specimen as shown in Fig. A14.5. Fiber-optic transducers have been used to measure load line displacement of SE(B) specimens. If the load line displacement is measured relative to the test fixture, care must be taken to account for the effects of fixture compliance and brinnelling on the measured displacement, as discussed in 8.3.1.1.

A14.5.6 Signal Conditioners—The user is referred to Guide E 1942 for a detailed discussion of requirements for data acquisitions systems. The signal conditioner must have sufficient bandwidth to capture the transducer signal without introducing distortion.

A14.5.6.1 Signal conditioners shall have a frequency bandwidth in excess of $10/t_Q$ for the load signal and $2/t_Q$ for the displacement signal(s). The more stringent requirement on the load signal is necessary to obtain an accurate measurement of the elastic component of the J integral near crack initiation. No “phase shifting” of transducer signals is allowed by this method. The bandwidth required to accurately capture a signal of that frequency will depend on the type of low-pass filter in the signal conditioner, and the tolerable error. If a low-pass filter is present in the measurement system it should not introduce more than 0.5 % measurement error, see Guide E 1942.

A14.5.7 Data Sampling—The user is referred to Guide E 1942 for a detailed discussion of requirements for data acquisitions systems. The rate at which an analog signal is sampled to create a digital signal shall be high enough to ensure that the peak value is accurately captured. The rate of data acquisition shall result in the time per data set being less than $t_Q/50$.

A14.6 Procedure

A14.6.1 Follow the procedure of Sections 7 and 8 to prepare and test specimens. The following items are additional steps necessary for high rate testing.

A14.6.2 Calculate t_{wz} , the minimum test time from Eq A14.1. The loading rate is optional but the time to reach $J_Q(t)$ or $J_{Qc}(t)$ shall not be less than t_{wz} .

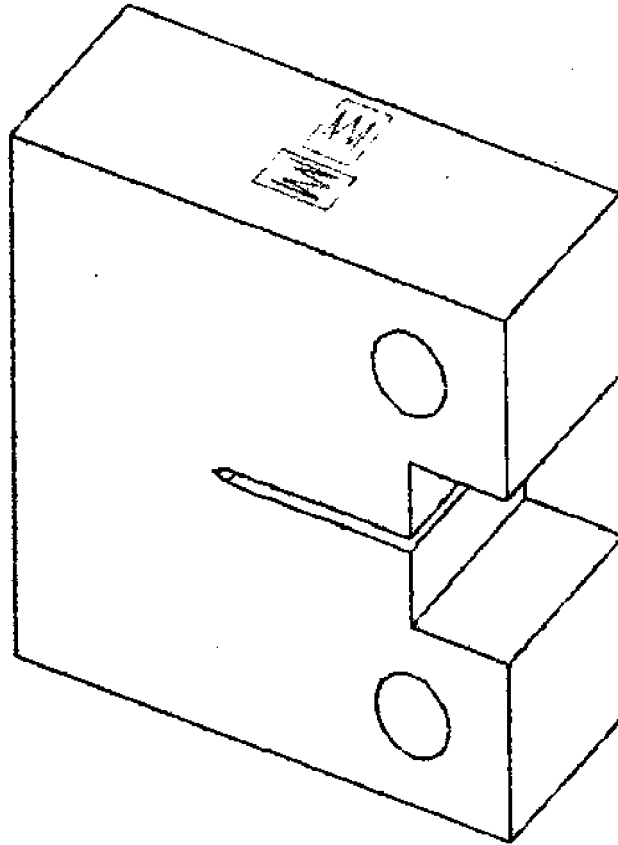

FIG. A14.2 Strain Gages Mounted on C(T) Specimen for Measurement of Transmitted Load

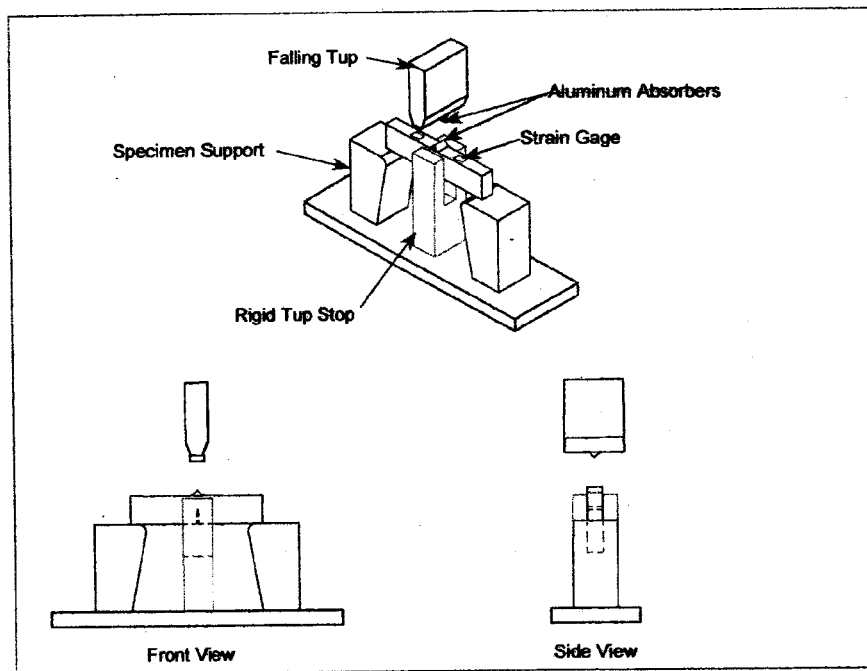

FIG. A14.3 Test Fixture for Drop Tower SE(B) Specimens

A14.6.3 For each test, load and load line displacement are required as functions of time. Additional crack opening displacement data, electric potential data, or both, can be acquired as well if desired.

A14.6.4 Install and align the specimen in the test fixtures, establish the test temperature, conduct the test at the desired test rate,

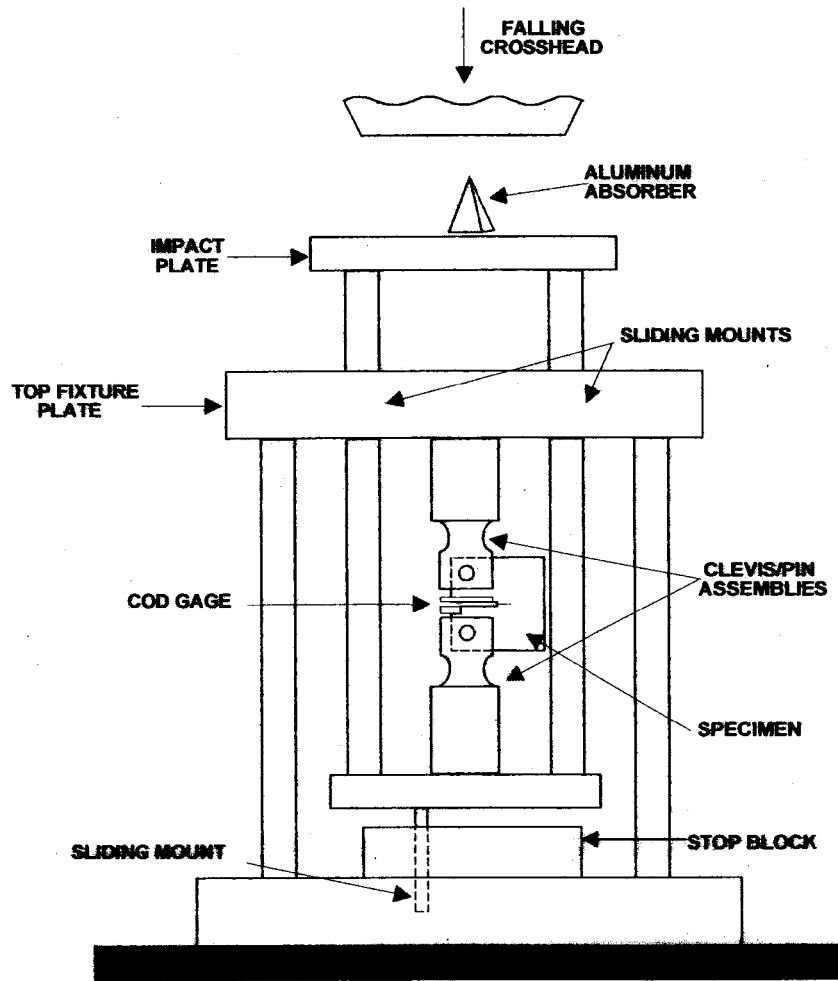

FIG. A14.4 Test Fixtures for Drop Tower C(T) Specimens

collect and store the data required. Remove the test specimen from the fixture and mark the extent of the ductile crack growth according to 8.5.3, break the specimen open according to 8.5.4 to expose the fracture surface, and measure the initial crack length a_o , and the final crack length a_f according to 8.5.5.

A14.6.5 If the specimen is characterized by ductile upper shelf behavior, the normalization method of Annex A15 can be used to develop the J - $R(t)$ curve for the test specimen. Using Section 9, calculate J_Q (the tentative J_{Ic}) and the corresponding load P_Q and time t_Q . If a ductile instability occurs so that the final stable crack length a_f cannot be determined, the normalization method cannot be used to develop the J - $R(t)$ curve or the corresponding J_Q for this test specimen.

A14.6.5.1 If a pop-in is present, refer to Annex A4 to assess its significance. If the pop-in is significant, $J_c(t)$ or $J_u(t)$ values corresponding to the point of onset can be calculated using Annex A6. If fracture instability occurs without significant ductile crack extension, $J_c(t)$ or $J_u(t)$ values corresponding to the point of onset can be calculated as defined in Annex A6. If fracture instability follows significant ductile crack extension, the J - $R(t)$ and $J_{Ic}(t)$ can be determined providing that a_f is distinguishable. The validity of the J - $R(t)$ curve and $J_{Ic}(t)$ are subject to the requirements of Annex A8, Annex A9, and Section 9.

A14.7 Qualification of the Data

A14.7.1 Test equipment, specimen geometries, specimen fixture alignment, and measured data must meet all requirements of Sections 6, 7, 8, and 9, except as specifically replaced in A14.5. Additional requirements specified here are necessary for high rate testing.

A14.7.2 All of the test equipment requirements of A14.5 shall be met.

A14.7.3 Plot the J integral versus the time as shown in Fig. A14.6. If fracture instability occurs, calculate J based on a_o using the basic analysis procedure and plot the data up to and including $J_{Qc}(t)$ or $J_{Qu}(t)$. Use a linear regression analysis to evaluate $(dJ/dt)_I$ as shown in the example of Fig. A14.5 using the data from $0.5J_Q(t)$ to $J_Q(t)$, from $0.5J_{Qc}(t)$ to $J_{Qc}(t)$, or from $0.5J_{Qu}(t)$ to $J_{Qu}(t)$, as the case may be. Extrapolate this line to the abscissa to evaluate the quantity t_Q , as shown in Fig. A14.6.

A14.7.3.1 A second loading rate, $(dJ/dt)_T$, is defined as the slope of the J versus time data beyond maximum load, as shown in Fig. A14.6, over the range from J_Q to $J_Q + 0.5(J_{max} - J_Q)$ or the end of test, if fracture instability occurs.

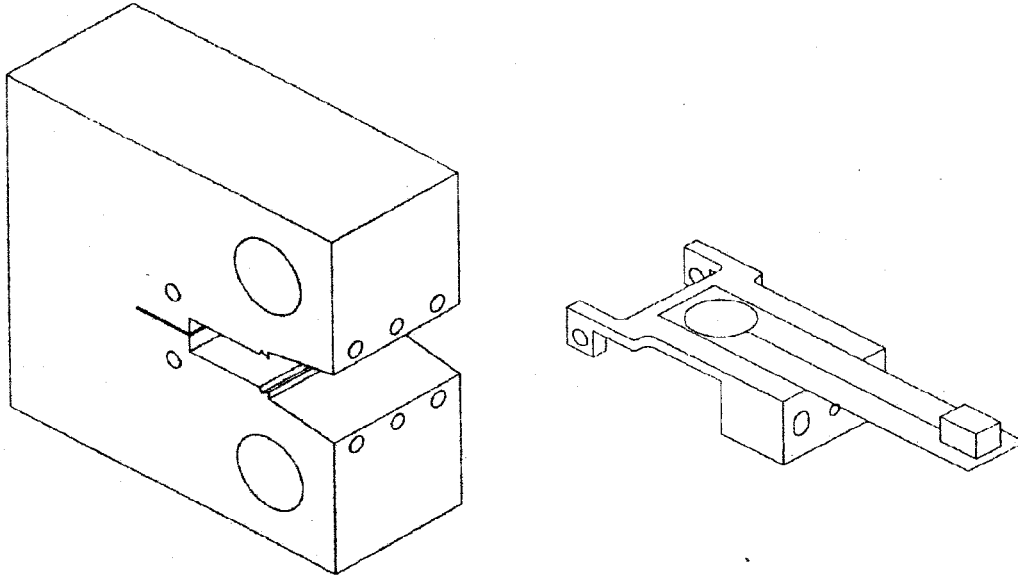

FIG. A14.5 High Rate Capacitance COD gage and C(T) Specimen with Attachment Holes

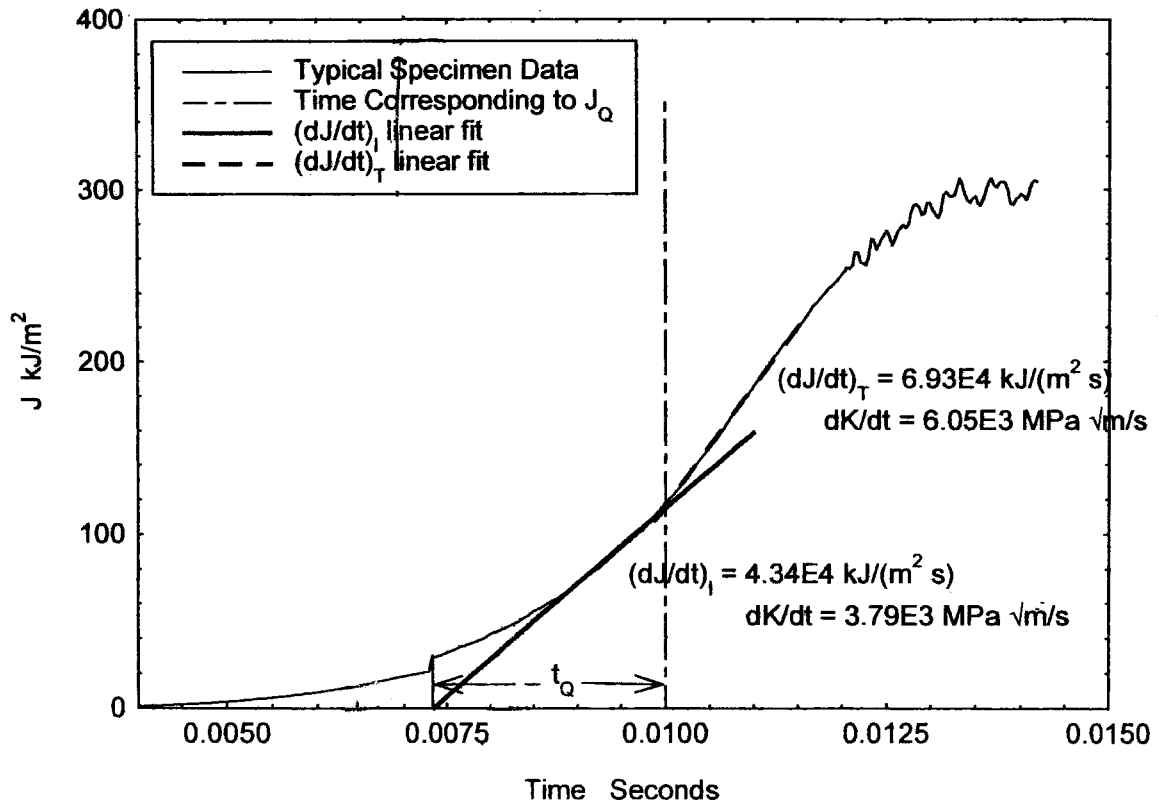

FIG. A14.6 Evaluation of t_Q and the Test Rates $(dJ/dt)_I$ and $(dJ/dt)_T$

A14.7.4 Plot load versus load line displacement for the time interval $0 \leq t \leq t_Q$, as shown schematically in Fig. A14.7. Use a linear regression analysis to evaluate the initial specimen stiffness k_s using data over the range from 20 % to 50 % of the maximum load measured in the test. Plot this best fit line on the figure, and also plot two parallel lines of the same slope with the y-intercept offset by $\pm 10\%$ of P_{max} as shown in Fig. A14.7. Locate the final crossover Δ_{II}^F .

A14.7.4.1 For this data set to be qualified according to this method, the compliance, $1/k_s$, shall agree with the predictions of Eq A2.10 for the C(T) specimen and Eq A1.9 for the SE(B) specimen within $\pm 10\%$. Additionally, the measured load displacement data in the region between $0.3\Delta_{II}^F$ and $0.8\Delta_{II}^F$ should remain within the bounds of the parallel lines constructed on Fig. A14.7.

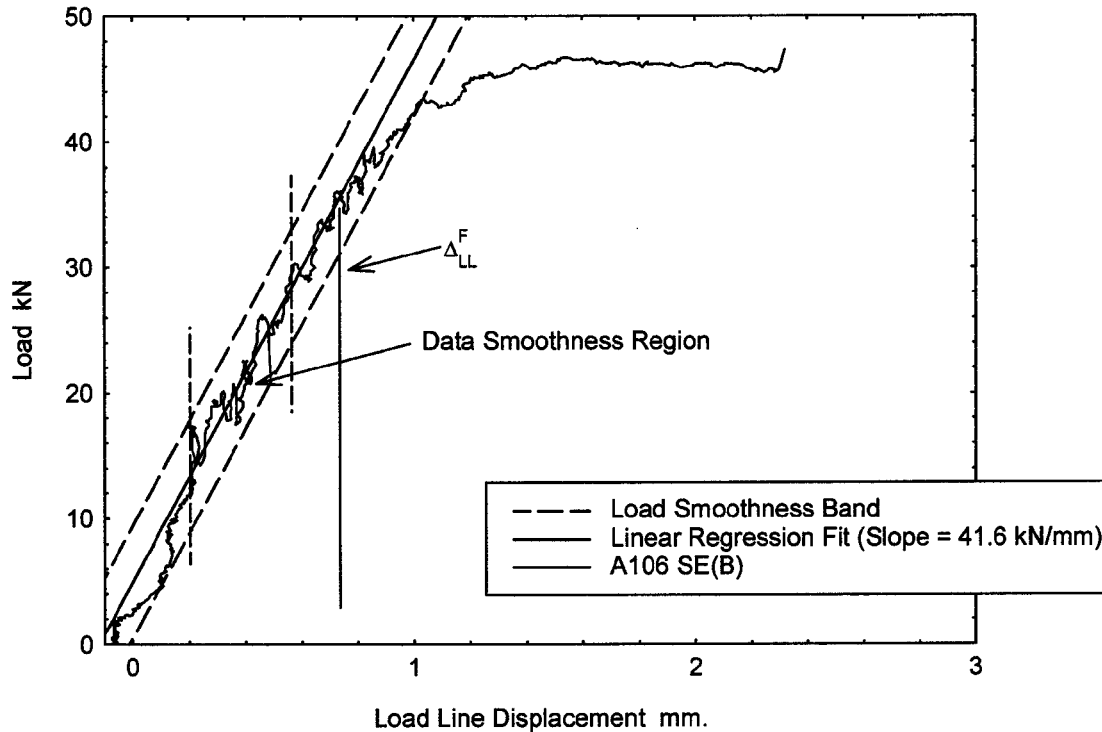

FIG. A14.7 Load Smoothness Verification Schematic

If these requirements are not met, slack grips or impact absorbers must be added or modified or the test rate reduced to obtain a smoother data set that can be qualified according to this method.

A14.7.5 If $t_Q < t_w$, the test data are not qualified according to this method. A slower loading rate must be used, or the specimen geometry changed to decrease t_w for the test to be qualified according to this method.

A14.7.6 If the normalization method of Annex A15 is used to obtain J_{Ic} , the J resistance curve, or both, at least one confirmatory specimen must be tested at the same test rate and under the same test conditions. From the normalization method the load line displacement corresponding to a ductile crack extension of 0.5 mm shall be estimated. The additional specimen shall then be loaded to this load line displacement level, marked, broken open and the ductile crack growth measured. The measured crack extension shall be 0.5 ± 0.25 mm in order for these results to be qualified according to this method.

A14.8 Qualifying the High Rate Results

A14.8.1 All qualification requirements of 9.1, Annex A6, Annex A8, Annex A9, and A14.7 must be met to qualify the J - $R(t)$ curve, $J_Q(t)$ as $J_{Ic}(t)$, or $J_{Qc}(t)$ as $J_c(t)$ according to this method. If the normalization method of Annex A15 is used, the additional requirements of this annex shall also be met.

A14.9 Report

A14.9.1 The report shall include all the items of Section 10 as well as the following:

A14.9.1.1 The minimum test time, t_w , according to A14.6.2.

A14.9.1.2 The P_Q and t_Q corresponding to the calculated $J_Q(t)$ or $J_{Qc}(t)$.

A14.9.1.3 The $(dJ/dt)_I$, $(dJ/dt)_T$ values, or both.

A14.9.1.4 If $J_{Ic}(t)$ is being reported, the final crack extension obtained on the confirmatory specimen of A14.7.6 shall be reported.

A14.10 Precision and Bias

A14.10.1 *Precision*—The precision of J versus crack growth is a function of material variability, the precision of the various measurements of linear dimensions of the specimen and testing fixtures, precision of the displacement measurement, precision of the load measurement, as well as the precision of the recording devices used to produce the load-displacement record used to calculate J and crack length. For the test rates allowed by this annex, if the procedures outlined in this annex are followed, the load and load-line displacement can be measured with a precision comparable with that of the static loading as described in the main body. If the normalization function method of Annex A15 is used, the crack length and crack extension information must be

inferred from initial and final crack length measurements. The requirement for the additional specimen to be tested near to the point of crack initiation has been added to validate the $J_{ic}(t)$ measurement. A round robin used to evaluate the overall test procedures of this method is reported in (20).

A14.10.2 *Bias*—There is no accepted “standard” value for measures of elastic-plastic fracture toughness of any material. In absence of such a true value, any statement concerning bias is not meaningful.

A15. NORMALIZATION DATA REDUCTION TECHNIQUE

A15.1 Scope

A15.1.1 The normalization technique can be used in some cases to obtain a *J-R* curve directly from a load displacement record taken together with initial and final crack length measurements taken from the specimen fracture surface. Additional restrictions are applied (see A14.1.3) which limit the applicability of this method. The normalization technique is described more fully in Herrera and Landes (21) and Landes, et al. (22), Lee (23), and Joyce (20). The normalization technique is most valuable for cases where high loading rates are used, or where high temperatures or aggressive environments are being used. In these, and other situations, unloading compliance methods are impractical. The normalization method can be used for statically loaded specimens if the requirements of this section are met. The normalization method is not applicable for low toughness materials tested in large specimen sizes where large amounts of crack extension can occur without measurable plastic load line displacement.

A15.2 Analysis

A15.2.1 The starting point for this analysis is a load versus load point displacement record like that shown in Fig. A15.1. Also required are initial and final physical crack lengths optically measured from the fracture surface. This procedure is applicable only to Test Method E 1820 standard specimen geometries with $0.45 \leq a_o/W \leq 0.70$ and cannot be used if the final physical crack extension exceeds the lesser of 4 mm or 15 % of the initial uncracked ligament.

A15.2.2 Each load value P_i up to, but not including the maximum load P_{max} , is normalized using:

$$P_{Ni} = \frac{P_i}{WB \left[\frac{W - a_{bi}}{W} \right]^{3/2}} \tag{A15.1}$$

where a_{bi} is the blunting corrected crack length at the *i*th data point given by:

$$a_{bi} = a_o + \frac{J_i}{2 \sigma_y} \tag{A15.2}$$

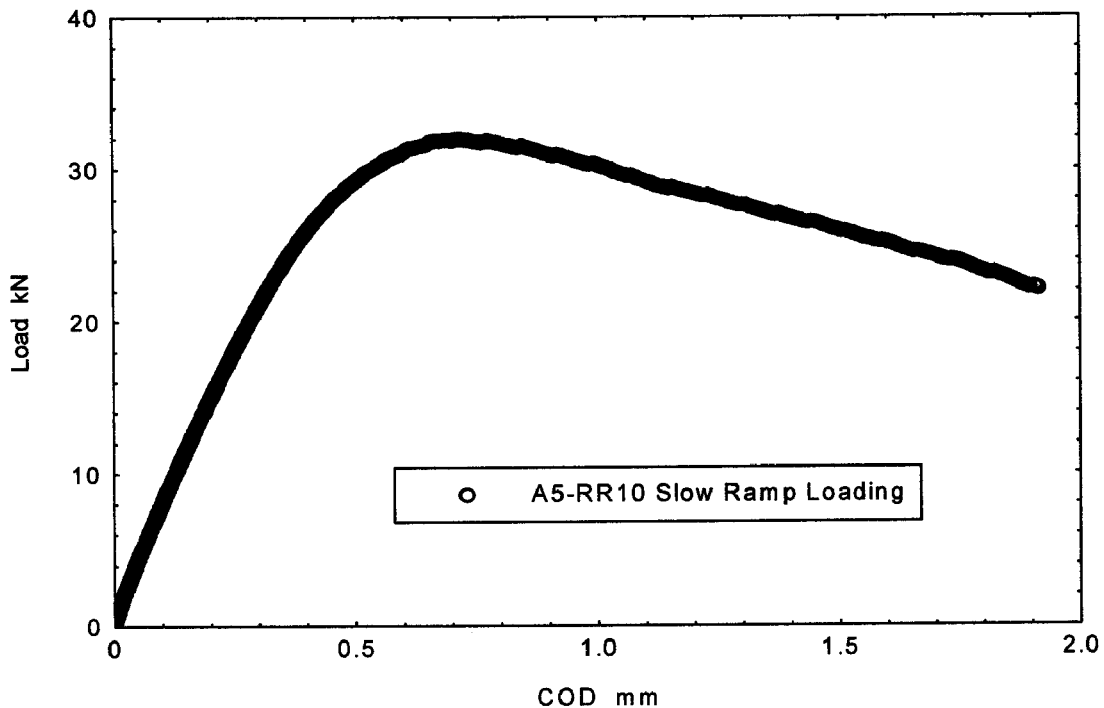

FIG. A15.1 Typical Load Versus Displacement Curve

with J_i calculated from:

$$J_i = \frac{K_i^2 (1 - \nu^2)}{E} + J_{pli} \tag{A15.3}$$

where K_i , η_{pl} , and J_{pli} are calculated as in Annex A1 and Annex A2 for each specimen type using the crack length a_i .
 A15.2.3 Each corresponding load line displacement is normalized to give a normalized plastic displacement:

$$v'_{pli} = \frac{v_{pli}}{W} = \frac{(v_i - P_i C_i)}{W} \tag{A15.4}$$

where C_i is the specimen elastic load line compliance based on the crack length a_{bi} , which can be calculated for each specimen type using the equations of Annex A1 and Annex A2.

A15.2.4 The final measured crack length shall correspond to a crack extension of not more than 4 mm or 15 % of the initial uncracked ligament, whichever is less. If this crack extension is exceeded, this specimen can not be analyzed according to this annex.

A15.2.5 The final load displacement pair shall be normalized using the same equations as above except that the final measured crack length, a_f is used. Typical normalized data are shown in Fig. A15.2.

A15.2.6 A line should be drawn from the final load displacement pair tangent to remaining data as shown in Fig. A15.2. Data to the right of this tangent point shall be excluded from the normalization function fit. Data with $v_{pli}/W \leq 0.001$ shall also be excluded from the normalization function fit.

A15.2.7 If at least ten data pairs conform with A15.2.6, the data of Fig. A15.2 can be fit with the following required analytical normalization function:

$$P_N = \frac{a + b v'_{pl} + c v'_{pl}{}^2}{d + v'_{pl}} \tag{A15.5}$$

where a , b , c , and d are fitting coefficients. This function can be fitted to the data of Fig. A15.1 using standard curve fitting packages available as part of computer spreadsheet programs or separately. An example fit for the data of Fig. A15.2 is shown in Fig. A15.3. The normalization function shall fit all the data pairs described above (including the final pair) with a maximum deviation less than 1 % of the P_N at the final point. Data should be evenly spaced between $v_{pli}/W = 0.001$ and the tangency point. If less than ten data pairs are available for this fit, including the final measured data pair, this method cannot be used.

A15.2.8 An iterative procedure is now used to force all P_{Ni} , v_{pli}/W , a_i data to lie on Equation A15.5. This involves adjusting

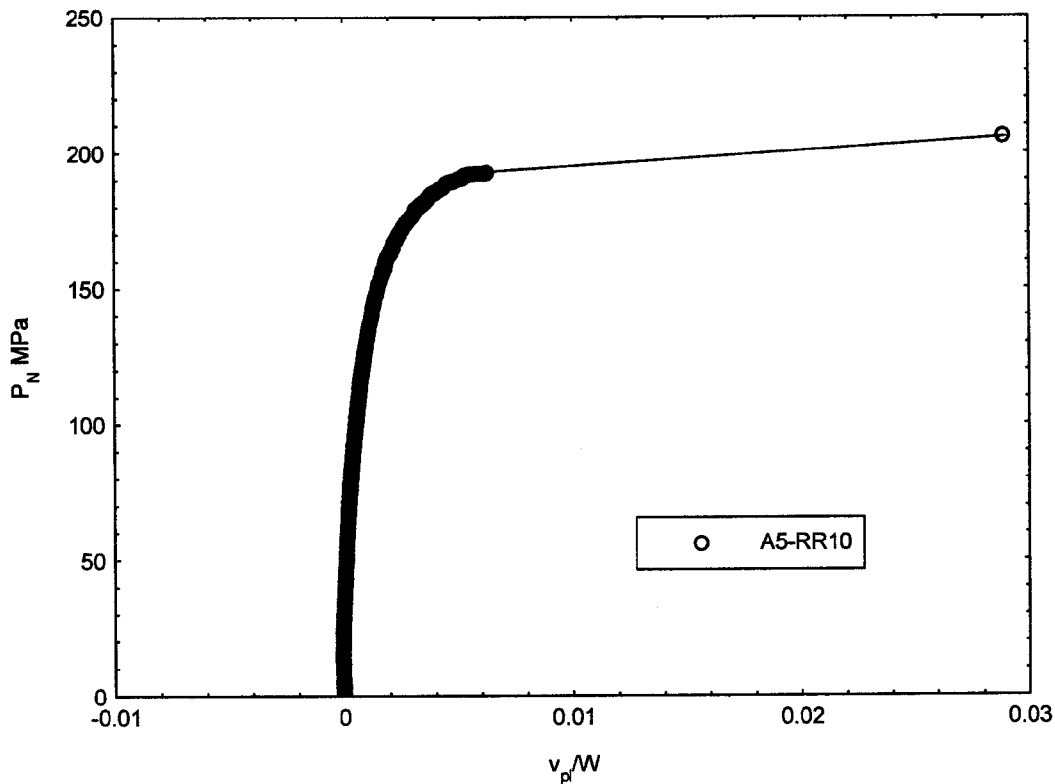

FIG. A15.2 Normalized Load Versus Displacement Curve Showing Points up to Maximum Load and the Final Data Point

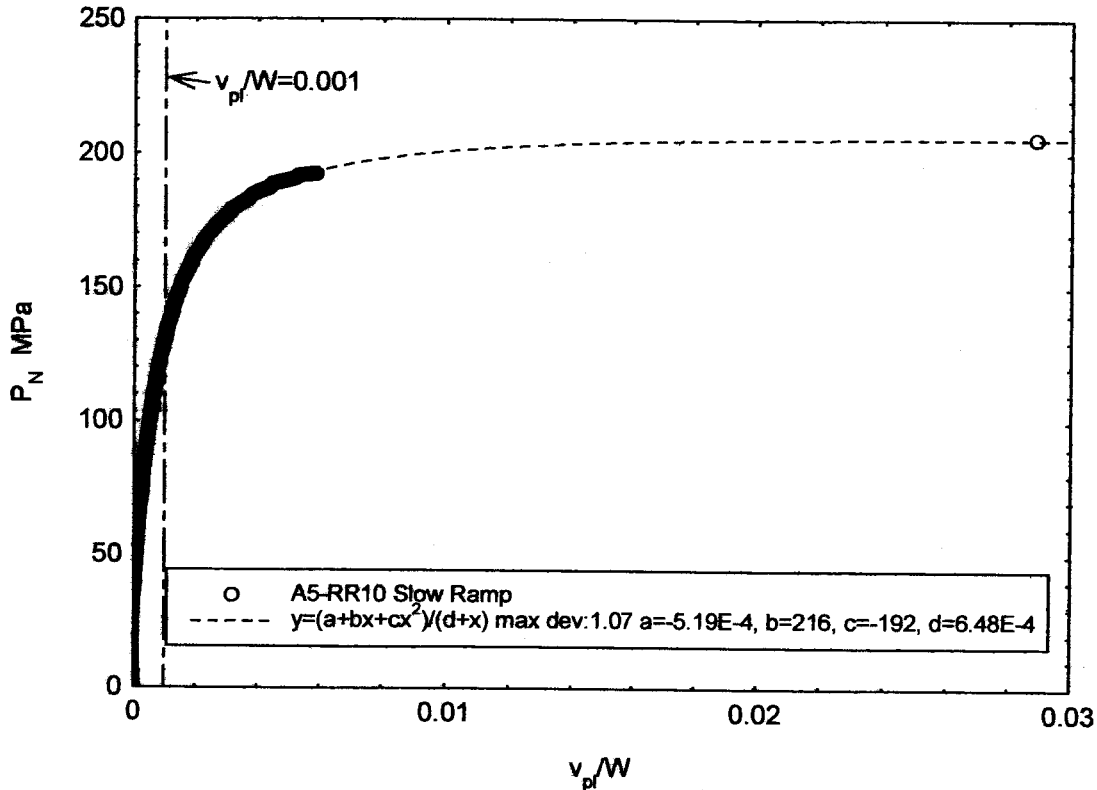

FIG. A15.3 The Normalization Function Shown Fitted to the Normalization Data

the crack size of each data set to get the normalized load and displacement pair defined in A15.2.2 and A15.2.3 to fall on the function defined in Equation A15.5. To do so, start at the first data point with a positive plastic load line displacement, normalize the load and displacement using the initial measured crack size a_o , and compare the normalized load with the result of the normalization function of A15.2.7. Adjust the crack size until the measured P_N and the functional value of P_N are within $\pm 0.1\%$. Each subsequent data set is treated similarly. If each step is started with the crack length resulting from the previous data set, only small, positive adjustments of crack length are necessary, and the process of obtaining the crack lengths corresponding to each data set is relatively rapid.

A15.2.8.1 The data of Fig. A15.1, normalized and adjusted to fit the normalization function of Fig. A15.3 is shown in Fig. A15.4.

A15.2.9 Since load, load line displacement, and crack length estimates are now available at each data point, the standard equations of Annex A1 and Annex A2 are used to evaluate the J integral at each data point, resulting in a J - R curve as shown in Fig. A15.5. A J_{Ic} value can now be evaluated from this J - R curve using the method of Section Annex A9.

A15.3 Additional Requirements

A15.3.1 Requirements presented in 9.1, Annex A8, and Annex A9 shall be met to qualify a J - R curve or a J_{Ic} value obtained by the normalization method. Additional requirements specific to the use of the normalization method are presented below.

A15.3.2 If the normalization method is used to obtain J_{Ic} , at least one additional, confirmatory specimen shall be tested at the same test rate and under the same test conditions. From the normalization method the load line displacement corresponding to a ductile crack extension of 0.5 mm shall be estimated. The additional specimen shall then be loaded to this load line displacement level, marked, broken open and the ductile crack growth measured. The measured crack extension shall be 0.5 ± 0.25 mm in order for these results, and hence the J_{Ic} value, to be qualified according to this method.

A15.4 Report

A15.4.1 Section 10 describes the reporting requirements for this method. If the normalization function method is used the following additional items shall be reported.

A15.4.2 If the normalization function is used the coefficients of the fit shall be reported as well as the maximum deviation of the fit and the number of data used.

A15.4.3 If J_{Ic} is reported, the accuracy of the confirmatory specimen of A15.3.2 shall be reported.

A15.5 Precision and Bias

A15.5.1 Precision—The precision of the J resistance curve is a function of material variability, the precision of the various

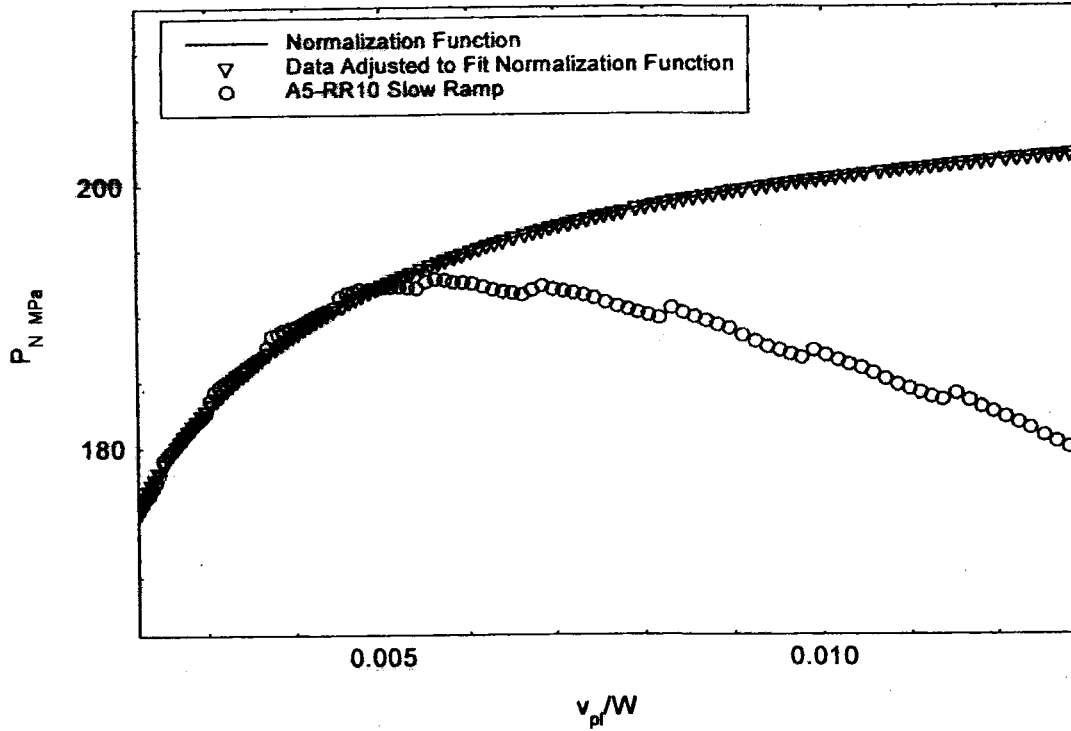

FIG. A15.4 Data is Adjusted, Defining the Crack Length Necessary to Place All Points on the Analytical Normalization Function. (Only a portion of the data is shown for clarity.)

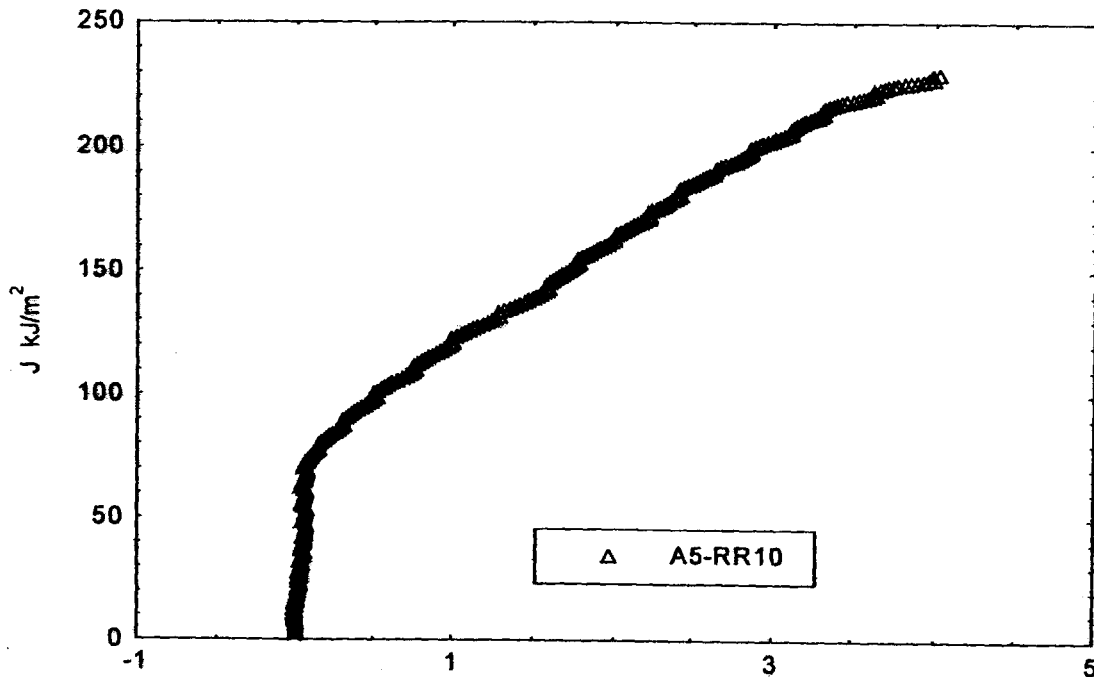

FIG. A15.5 The Resulting J-R Curve for this Specimen

measurements of linear dimensions of the specimen and testing fixtures, precision of the displacement measurement, precision of the load measurement, as well as the precision of the recording devices used to produce the load-displacement record used to calculate J and crack length. For the test rates allowed by this annex, if the procedures outlined in this annex are followed, the crack length throughout the fracture toughness test can be measured with a precision comparable with that of the unloading compliance procedure described in the main body. A round robin describing the use of the normalization procedure on rapidly loaded SE(B)

and C(T) specimens is presented in (20). A requirement for the testing of a confirmatory specimen tested near the point of stable crack initiation is present to validate the J_{Ic} measurement.

A15.5.2 *Bias*—Crack lengths generally vary through the thickness of fracture toughness specimens. A nine point average procedure based on optical measurements obtained from the post-test fracture surface is generally used to give a reportable crack length. Different measurements would be obtained using more or less measurement points. Alternative crack lengths can be estimated using compliance methods, which obtain different average crack length estimates for irregular crack front shapes. Stringent crack front straightness requirements are present in this standard to minimize differences caused by these effects. The normalization method acts to interpolate between optically measured crack average lengths measured at the start and end of the stable resistance curve fracture toughness test. This method has been demonstrated in (20) to give results consistent with those obtained by unloading compliance procedures.

I —

APPENDIX

(Nonmandatory Information)

X1. BASIC CODE EXAMPLE

X1.1 Fig. X1.1 To fit Eq A9.1 to the J_p , a_i data using the method of least squares, the following equation must be set up and solved for a_{oq} , B , and C :

$$\left\{ \begin{array}{l} \Sigma a_i - \frac{\Sigma J_i}{2\sigma_Y} \\ \Sigma a_i J_i^2 - \frac{\Sigma J_i^3}{2\sigma_Y} \\ \Sigma a_i J_i^3 - \frac{\Sigma J_i^4}{2\sigma_Y} \end{array} \right\} = \left[\begin{array}{l} n \Sigma J_i^2 \Sigma J_i^3 \\ \Sigma J_i^2 \Sigma J_i^4 \Sigma J_i^5 \\ \Sigma J_i^3 \Sigma J_i^5 \Sigma J_i^6 \end{array} \right] \left\{ \begin{array}{l} a_{oq} \\ B \\ C \end{array} \right\} \quad (X1)$$

X1.2 This equation can be set up and solved using a standard spreadsheet. The following listing gives a Microsoft QuickBASIC program listing that can also be used to accomplish this process. This algorithm can be easily modified to perform the fit for CTOD calculations required in C4.4.1.

```

SUB JFIT
,
,
SUBROUTINE TO SET UP FUNCTION FOR Aoq EVALUATION
,
USES EQUATION a = Aoq + J/(2*SFLOW) + B J ^ 2 + C J ^ 3
,
,
WRITTEN BY J. A. Joyce USNA, Annapolis, 1993
,
,
INPUT IS RDAT % PAIRS OF a AND J IN VECTOR ARRAYS AM! AND
JM!
,
,
NEED IN MAIN PROGRAM A COMMON SHARED RDAT %, AM!(), JM!(),
XN!(), FF!(), AN!(), SFLOW!
,
,
INITIALIZATION
FOR I % = 1 TO 3
FOR J % = 1 TO 4
AN!(I %,J %) = 0.
NEXT J %
NEXT I %
,
DO SUMMATIONS FOR LEAST SQUARES
AN!(1,1) = RDAT %
JISUM! = 0.

```

FIG. X1.1 BASIC Program



```
FOR I % = 1 TO RDAT %
  JISUM! = JISUM! + JM!(I %)
  AN!(1,2) = AN!(1,2) + JM!(I %) ^ 2
  AN!(2,2) = AN!(2,2) + JM!(I %) ^ 4
  AN!(1,3) = AN!(1,3) + JM!(I %) ^ 3
  AN!(2,3) = AN!(2,3) + JM!(I %) ^ 5
  AN!(3,3) = AN!(3,3) + JM!(I %) ^ 6
  AN!(1,4) = AN!(1,4) + AM!(I %)
  AN!(2,4) = AN!(2,4) + AM!(I %)*JM!(I %) ^ 2
  AN!(3,4) = AN!(3,4) + AM!(I %)*JM!(I %) ^ 3
NEXT I %
AN!(2,1) = AN!(1,2)
AN!(3,1) = AN!(1,3)
AN!(3,2) = AN!(2,3)
AN!(1,4) = AN!(1,4) - JISUM!/(2*SFLOW!)
AN!(2,4) = AN!(2,4) - AN!(1,3)/(2*SFLOW!)
AN!(3,4) = AN!(3,4) - AN!(2,2)/(2*SFLOW!)
NOW SOLVE THESE EQUATIONS USING GAUSS ELIMINATION FOR
  XN!
CALL GAUSS
PRINT "COEFFICIENTS OF INITIALIZATION ARRAY ARE:"
PRINT XN!(1), XN!(2), XN!(3)

CHECK THE FIT
FOR I % = 1 TO RDAT %
  FF!(I %) = XN!(1)+JM!(I %)/(2*SFLOW!)+XN!(2)*JM!(I %) ^ 2+XN!(3)
  *JM!(I %) ^ 3
  PRINT JM!(I %), AM!(I %), FF!(I %)
NEXT I %
CALCULATION OF THE CORRELATION OF THE FIT
YM! = 0.
FOR I % = 1 TO RDAT %
  YM! = YM! + AM!(I %)/RDAT %
NEXT I %
SY2! = 0.
SYX2! = 0.
FOR I % = 1 TO RDAT %
  SY2! = SY2! + (AM!(I %) - YM!) ^ 2/(RDAT %-1)
  SYX2! = SYX2! + (AM!(I %) - FF!(I %)) ^ 2/(RDAT %-2)
NEXT I %
RFIT! = SQR(1.0 - SYX2!/SY2!)
PRINT "CORRELATION OF FIT = ";RFIT!
PRINT #2,"CORRELATION OF FIT = ";RFIT!
END SUB
SUB GAUSS
  INPUT DATA IS IN AN!(3,4) - OUTPUT IS XN!(3)
```

FIG. X1.1 BASIC Program (continued)

```

SUBROUTINE IN BASIC TO DO A GAUSS ELIMINATION SOLUTION
SET NOW FOR 3X3 MATRIX
OUTPUT IS A VECTOR XN
N % = 3
M % = N % + 1
L % = N % - 1
START REDUCTION TO TRIANGULAR FORM
FOR K % = 1 TO L %
  K1 % = K % + 1
  JJ % = K %
  BG! = ABS(AN!(K %,K %))
REM START OF SEARCH FOR LARGEST PIVOT ELEMENT
FOR I % = K1 % TO N %
  AB! = ABS(AN!(I %,K %))
  IF BG! > AB! THEN BG! = AB!: JJ % = I %
NEXT I %
IF JJ % = K % GOTO REDUCE
INTERCHANGES ROWS TO GET MAX PIVOT ELEMENT
FOR J % = K % TO M %
  TE! = AN!(JJ %,J %)
  AN!(JJ %,J %) = AN!(K %,J %)
  AN!(K %,J %) = TE!
NEXT J %
,
DETERMINES REDUCED ELEMENTS OF TRIANGULAR SET
REDUCE:
FOR I % = K1 % TO N %
  Q! = AN!(I %, K %)/AN!(K %, K %)
  FOR J % = K1 % TO M %
    AN!(I %, J %) = AN!(I %, J %) - Q!*AN!(K %, J %)
  NEXT J %
NEXT I %
FOR I % = K1 % TO N %
  AN!(I %,K %) = 0.
NEXT I %
NEXT K %
BACK SUBSTITUTION FOR THE SOLUTIONS
XN!(N %) = AN!(N %,M %)/AN!(N %, N %)
FOR NN % = 1 TO L %
  SU! = 0.
  I % = N % - NN %
  I1 % = I % + 1
  FOR J % = I1 % TO N %
    SU! = SU! + AN!(I %, J %) * XN!(J %)
  NEXT J %
  XN!(I %) = (AN!(I %, M %) - SU!)/AN!(I %,I %)
NEXT NN %
END SUB

```

FIG. X1.1 BASIC Program (continued)

REFERENCES

- (1) Joyce, J. A., and Tregoning, R. L., "Development of Consistent Size Criteria for ASTM Combined Fracture Mechanics Standards," *Fatigue and Fracture Mechanics*, Vol 30, ASTM STP 1360, P. C. Paris, et al, eds., ASTM, West Conshohocken, PA, 1999.
- (2) Joyce, J. A., "Manual on Elastic-Plastic Fracture: Laboratory Test Procedures," ASTM Manual Series MNL 27, 1996.
- (3) Dawes, M. G., "Elastic-Plastic Fracture Toughness Based on the COD and *J*-Integral Concepts," *Elastic-Plastic Fracture ASTM STP 668*, J. D. Landes, J. A. Begley, and G. A. Clarke, eds., ASTM, 1979, pp. 307–333.
- (4) Willoughby, A. A., and Garwood, S. J., "On the Loading Compliance Method of Deriving Single Specimen *R*Curves in Three Point Bending," *Elastic-Plastic Fracture: Second Symposium, Volume II—Fracture Resistance Curves and Engineering Applications*, ASTM STP 803, C. F. Shih and J. P. Gudas, eds., ASTM, 1983, pp. II-372–II-397.
- (5) Hackett, E. M., and Joyce, J. A., "Dynamic *J-R* Curve Testing of a High Strength Steel Using Key Curve and Multi-Specimen Techniques," *Fracture Mechanics*, Seventeenth Volume, ASTM STP 905, ASTM, 1986, pp. 741–774.
- (6) Hellman, D., Rohwerder, G., and Schwalbe, K. H., "Development of a Test Setup for Measuring Deflections of Single Edge Notched Bend (SENB) Specimens," *Journal of Testing and Evaluation*, Vol 12, No. 1, January 1984, pp. 62–64.
- (7) KarisAllen, K. J. and Mathews, J. R., "The Determination of Single Edge-Notched Bend Specimen Load-Line Displacement from Remotely Located Sensors in Elastic-Plastic Fracture Testing," *Journal of Testing and Evaluation*, JTEVA, Vol 22, No. 6, Nov. 1994, pp. 581-583.
- (8) McCabe, D. E., "Evaluation of the Compact Specimen for Plane Strain Fracture Toughness of High Strength Materials," *Journal of Materials*, Vol 7, No. 4, December 1972, p. 449.
- (9) Begley, J. A., Clarke, G. A., and Landes, J. D., "Results of an ASTM Cooperative Test Program on the J_{Ic} Determination of HY-130 Steel," *Journal of Testing and Evaluation*, Vol 8, No. 5, September 1980.

- (10) Gudas, J. P., and Davis, D. A., "Evaluation of the Tentative J - R Curve Testing Procedure by Round Robin Tests of HY-130 Steel," *Journal of Testing and Evaluation*, Vol 10, No. 6, November 1982, pp. 252–262.
- (11) Srawley, J. E., "Wide Range Stress Intensity Factor Expressions for ASTM E399 Standard Fracture Toughness Specimens," *International Journal of Fracture*, Vol 12, June 1976, pp. 475–476.
- (12) Newman, J. C., Jr., "Stress Analysis of the Compact Specimen Including the Effects of Pin Loading," *ASTM STP 560*, 1974, pp. 105–121.
- (13) Newman, J. C., Jr., "Stress Intensity Factors and Crack Opening Displacements for Round Compact Specimens," *International Journal of Fracture*, 17(6), December 1981, pp. 567–578.
- (14) Underwood, J. H., Kapp, J. A., and Baratta, F. I., "More on Compliance of the Three-Point Bend Specimen," *International Journal of Fracture*, Vol 28, 1985, pp. R41–R45.
- (15) Saxena, A., and Hudak, S. J., "Review and Extension of Compliance Information for Common Crack Growth Specimens," *International Journal of Fracture*, Vol 14, October 1978, pp. 453–468.
- (16) Yoon, K. K., Gross, L. B., Wade, C. S., and VanDerSluys, W. A., "Evaluation of Disk-Shaped Specimen for Determining J-R Curves," *Fracture Mechanics: 26th Volume, ASTM STP 1256*, W. G. Reuter, J. H. Underwood, and J. C. Newman, eds., American Society for Testing and Materials, Philadelphia, 1995.
- (17) Shoemaker, A. K., and Seeley, R. R., "Summary Report of Round Robin Testing By ASTM Task Group E24.01.06 on Rapid Loading Plane Strain Fracture Toughness K_{Ic} Testing," *Journal of Testing and Evaluation*, Vol 11, No. 4, July 1983.
- (18) Nakamura, T., Shih, C.F., and Freund, L.B., "Analysis of a Dynamically Loaded Three-Point-Bend Ductile Fracture Specimen," *Engineering Fracture Mechanics*, Vol. 25, No. 3, 1986, pp. 323–339.
- (19) Joyce, J.A., and Hackett, E.M., "An Advanced Procedure for J-R Curve Testing Using a Drop Tower," *Nonlinear Fracture Mechanics: Vol. 1–Time Dependent Fracture*, ASTM STP 995, A. Saxena, J.D. Landes, and J.L. Bassani, Eds., ASTM, Philadelphia, 1989, pp. 298–317.
- (20) Joyce, J.A., "Analysis of the E08.02 High Rate Round Robin," *Journal of Testing and Evaluation*, JTEVA, Vol. 29, No. 4, July 2001, pp. 329–351.
- (21) Herrera, R., and Landes, J.D., "Direct J-R Curve Analysis: A Guide to the Methodology," *Fracture Mechanics: Twenty-First Symposium*, ASTM STP 1074, J.P. Gudas, J.A. Joyce, and E.M. Hackett, Eds., ASTM, Conshohocken, PA, 1990, pp 24–43.
- (22) Landes, J.D., Zhou, Z., Lee, K., and Herrera, R., "Normalization Method for Developing J-R Curves with the LMN Function," *Journal of Testing and Evaluation*, JTEVA, Vol. 19, No. 4, July 1991, pp. 305–311.
- (23) Lee, Kang, "Elastic-Plastic Fracture Toughness Determination Under Some Difficult Conditions," Ph.D Dissertation, The University of Tennessee, Knoxville, August, 1995.

ASTM International takes no position respecting the validity of any patent rights asserted in connection with any item mentioned in this standard. Users of this standard are expressly advised that determination of the validity of any such patent rights, and the risk of infringement of such rights, are entirely their own responsibility.

This standard is subject to revision at any time by the responsible technical committee and must be reviewed every five years and if not revised, either reapproved or withdrawn. Your comments are invited either for revision of this standard or for additional standards and should be addressed to ASTM International Headquarters. Your comments will receive careful consideration at a meeting of the responsible technical committee, which you may attend. If you feel that your comments have not received a fair hearing you should make your views known to the ASTM Committee on Standards, at the address shown below.

This standard is copyrighted by ASTM International, 100 Barr Harbor Drive, PO Box C700, West Conshohocken, PA 19428-2959, United States. Individual reprints (single or multiple copies) of this standard may be obtained by contacting ASTM at the above address or at 610-832-9585 (phone), 610-832-9555 (fax), or service@astm.org (e-mail); or through the ASTM website (www.astm.org).