



Designation: D 4971 – 89 (Reapproved 1998)

Standard Test Method for Determining the In Situ Modulus of Deformation of Rock Using the Diametrically Loaded 76-mm (3-in.) Borehole Jack¹

This standard is issued under the fixed designation D 4971; the number immediately following the designation indicates the year of original adoption or, in the case of revision, the year of last revision. A number in parentheses indicates the year of last reapproval. A superscript epsilon (ϵ) indicates an editorial change since the last revision or reapproval.

1. Scope

1.1 This test method covers the estimation of in situ modulus of a rock mass at various depths and orientations. Information on time-dependent deformation may also be obtained.

1.2 The values stated in SI units are regarded as standard. The inch-pound units in parentheses are for information only.

1.3 *This standard does not purport to address all of the safety concerns, if any, associated with its use. It is the responsibility of the user of this standard to establish appropriate safety and health practices and determine the applicability of regulatory limitations prior to use.*

2. Referenced Documents

2.1 *ASTM Standards:*

D 653 Terminology Relating to Soil, Rock and Contained Fluids²

3. Terminology

3.1 *Definitions of Terms Specific to This Standard:*

3.1.1 *deformation*—change in shape or size, (see Terminology D 653). In this test method deformation is the change in the diameter of the borehole.

3.1.2 *modulus of deformation*—ratio of stress to strain for a material under given loading conditions; numerically equal to the slope of the tangent or the secant of the stress-strain curve. The use of the term modulus of elasticity is recommended for materials that deform in accordance with Hooke's law, and the term modulus of deformation is recommended for materials that deform otherwise, (see Terms D 653). In this test method, the modulus of deformation is calculated from the applied fluid pressure, the relative change in hole diameter, a function of Poisson's ratio, and a constant.

4. Summary of Test Method

4.1 The 76 mm (3.0 in.) jacks, (see Fig. 1 and Fig. 2), induce unidirectional pressure to the walls of a borehole by means of

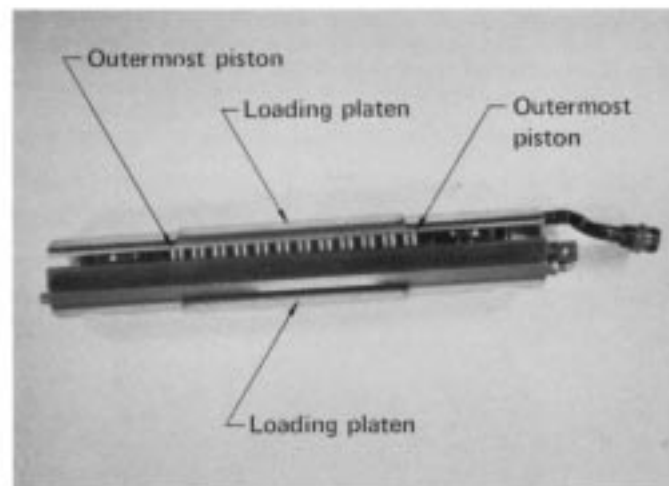

a) Assembled

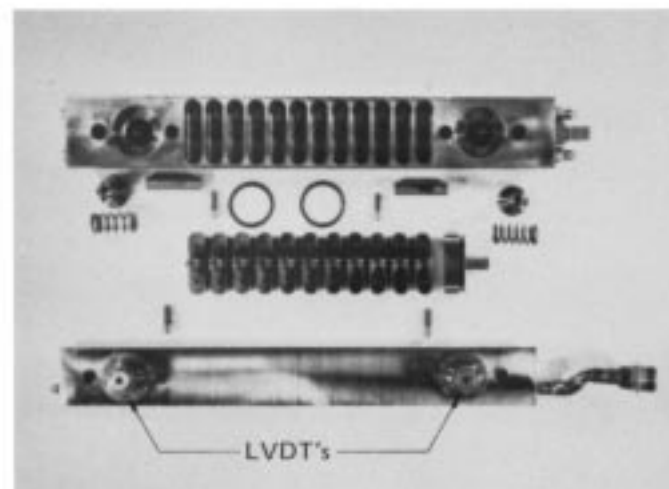

b) Disassembled

FIG. 1 The 76-mm (3-in.) Borehole Jack

¹ This test method is under the jurisdiction of ASTM Committee D-18 on Soil and Rock and is the direct responsibility of Subcommittee D18.12 on Rock Mechanics.

Current edition approved July 28, 1989. Published October 1989.

² *Annual Book of ASTM Standards*, Vol 04.08.

two opposed curved steel platens each covering a 90° sector, over a length of 20.3 cm (8 in.).

4.2 Raw data from a test consist of hydraulic-line pressure,

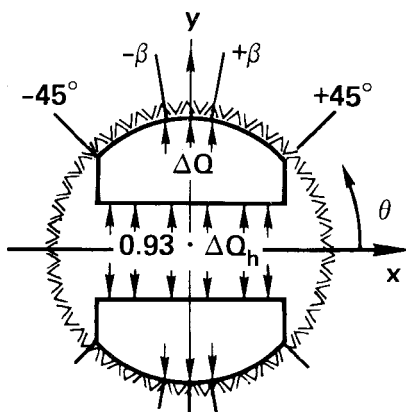

FIG. 2 Schematic of Loading of the Borehole Jack

Q_h , versus readout from linear variable differential transformers (LVDT's) measuring platen movement. Knowing the displacement calibration of the LVDT's, the raw data can be transformed to a test record of hydraulic pressure versus hole diameter, D . For each increment of pressure, ΔQ_h , and hole deformation, ΔD , theoretical data analysis (1),³ assuming rigid jack plates and full 90° contact, give the theoretical rock mass modulus, E ($E_{\text{theoretical}}$) as a function $E = f(\Delta Q_h, \Delta D, T^*)$, where T^* is a coefficient dependent upon Poisson's ratio. If E is measured on a linear segment of the loading curve, common terminology is modulus of deformation. If E is measured on an unloading linear segment, it is referred to as the recovery modulus.

5. Significance and Use

5.1 Results of this test method are used to predict displacements in rock mass caused by loads from a structure or from underground construction. It is one of several tests that should be performed.

5.2 Because the jack can apply directed loads, this test method can be performed to provide an estimate of anisotropy.

5.3 In theory, the analysis of test data is straight forward; the modulus estimate requires a record of applied hydraulic pressure versus borehole diameter change, and a knowledge of the rock's Poisson's ratio. In practice, the above procedure, using the original theoretical formula, frequently has resulted in computing a material modulus that was demonstrably too low.

5.4 For analyzing the test data it is assumed that the rock mass is linearly elastic, isotropic, and homogeneous. Within these assumptions, this test method can provide useful data for rock masses for which equivalent continuous properties can not be found or estimated.

6. Interferences

6.1 It is assumed that the tensile and compressive moduli of the rock are equal and there is not tensile cracking induced in the rock mass because of jack loading. If tensile cracks are created at 90° to the loading direction, it has been shown (1)

that the calculated modulus values can decrease by up to 29%. Therefore, tensile cracking would result in a decrease in the slope of the loading curve and test data in the region of decreased slope should not be used.

6.2 The volume of rock mass involved in the 76 mm (3.0 in.) diameter jack test has been estimated (2) to be about 0.15 m³ (5 ft³). This volume may not include enough discontinuities to be representative of the rock mass on a larger scale.

6.3 Two aspects of jack behavior, discussed in 6.3.1 and 6.3.2, require careful consideration in the analysis of test data and can be compensated for by the procedure outlined in this test method and detailed by Heuze and Amadei (3).

6.3.1 The platen/rock contact may not cover 90° of the borehole circumference, as assumed, because of radius mismatch between the jack and the hole (4, 5).

6.3.2 In rock with modulus of deformation greater than about 7 GPa (10⁶ psi), there is a longitudinal concave outward bending of the jack platens that requires correction. This correction is necessary because the bending gives higher displacements at the ends than at the center of the loading platens and LVDT displacement gages are located near the ends of the platens.

7. Apparatus

7.1 *Borehole Jack*—The borehole jack for which equations and corrections are presented in Section 12 is the so-called "hard rock" jack, that is currently manufactured under patent. The manufacturer's specifications are: range of travel is 13 mm (0.5 in.) from closed at 70 mm (2.75 in.) to fully open at 83 mm (3.25 in.), maximum pressure on borehole wall is 64 MPa (9300 psi), and deformation resolution is 0.025 mm (0.001 in.). The maximum jack pressure is achieved with a hydraulic system pressure of 69 MPa (10 000 psi). Deformation is measured by an LVDT at each end of the loading platens. These are referred to as the near and far LVDT respectively.

7.2 *Pressure Gage*—A hydraulic gage or electronic transducer may be used to measure the hydraulic system pressure. The gage shall have an accuracy of at least 280 kPa (40 psi), including errors introduced by the readout equipment, and a resolution of at least 140 kPa (20 psi).

7.3 *Casing Alignment System*—The borehole jack is attached to 73 mm (2.875 in.) BX drill casing and placed into position in the borehole. To determine the orientation of the jack, an orientation mark is transferred to successive sections of casing as they are added. To avoid introducing a systematic and progressive error into orientation, an alignment device shall be used to transfer the mark from one casing section to another. In vertical boreholes, a plumb line may be sufficient. In inclined or horizontal boreholes, a marking guide such as the one shown on Fig. 3 has been found satisfactory (6).

8. Sampling, Test Specimens, and Test Units

8.1 *Number and Orientation of Boreholes*—The number, spacing, and orientation of boreholes depend on the geometry of the project and the geology of the site.

8.2 Rock Sampling:

8.2.1 Each type of rock should be tested. In addition, areas of low modulus of deformation, such as fracture or alteration

³ The boldface numbers in parentheses refer to a list of references at the end of the standard.

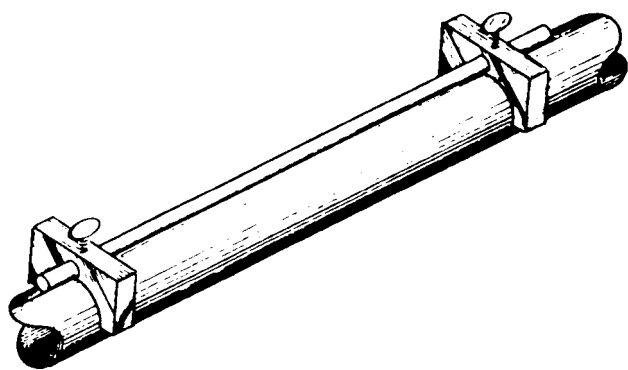

FIG. 3 Marking Guide on Section of Casing

zones within a rock mass, are of particular interest and should be tested.

8.2.2 Tests should be conducted at different orientations to sample the anisotropy of the rock mass, for example, parallel and perpendicular to the long axes of the columns in a basalt flow. Boreholes should generally be orthogonal to each other and either parallel or perpendicular to the structure of the rock formation. At least ten tests in each rock material are recommended.

8.3 *Boreholes Reamed*—It is recommended that a reaming shell with a nominal outside diameter of 76 mm (3 in.) be used. It is further recommended that a bit fabricated to reaming shell gage 76 mm (3 in.) also be used. This will minimize the radius mismatch between the borehole and the jack. Accurate measurement of the diameter of the borehole is important.

8.4 *Boreholes Cored*—The boreholes shall be drilled using diamond core techniques; continuous core should be obtained. Oriented cores are desirable but not mandatory.

8.5 *Core Logged*—The recovered core should be completely logged, with emphasis on fractures and other mechanical inhomogeneities and water pressure. Rock quality designation (RQD) should be calculated for each 1.5 m (5 ft) of hole cored or core run.

8.6 *Test Location*—Within each borehole, locations for each test should be selected based on the core logs. In some cases observation of the borehole with a borescope or borehole camera (film or television) may be useful.

9. Personnel and Equipment Requirements

9.1 *Personnel*—All personnel involved in performing the test, including technicians and test supervisors, should be under the guidance of someone thoroughly familiar with the use of the jack. Sometimes the personnel may be required to be formally pre-qualified under a quality assurance (QA) procedures established as part of the overall testing program.

9.2 *Equipment Performance Verification*—The compliance of all equipment and apparatus with performance specifications of this procedure shall be verified. Performance verification is generally done by calibrating the equipment and measurement systems according to established procedures.

10. Calibration

10.1 The borehole jack shall be calibrated before and at the completion of the program according to manufacturer's or

equivalent directions (7). In addition, the jack shall be calibrated during the test program if the program consists of many tests or if the deformation readings become suspect. This is particularly likely if the difference in the readings of near and far LVDT's exceeds the manufacturer's recommendation of 0.5 mm (0.02 in.), indicating excessive misalignment of the platens.

10.2 Calibration of the boreholes jack must be documented. Personnel using the equipment must be qualified in advance.

11. Procedure

11.1 Test each distinctive rock material in a borehole.

11.2 *Testing Discontinuities*—Locate tests in both intact zones and fractured zones to evaluate the effects of discontinuities. If the two LVDT's give significantly different displacement (≥ 0.5 mm or 0.02 in.), discard the data and relocate the jack.

11.3 *Boreholes*—Boreholes shall be free from dirt and drill cuttings. Wash the borehole with clean water if necessary.

11.4 *Initial Seating Pressure*—When the jack is at the test location and in the desired orientation, raise the hydraulic pressure to 350 kPa (50 psi) to seat the platens against the borehole wall. Use this pressure as the "zero" pressure throughout the remainder of the test.

11.5 *Pressure Level*—Test the rock to a pressure in excess of that required for full platen contact, but not exceeding the pressure or displacement capacity of the jack. Failure of the rock may be recognized by an increase in the rate of deformation without corresponding increase in the rate of pressure.

11.6 *Pressure Cycles*—In at least 25 % of the tests in each rock material, conduct multiple-pressure cycling to progressively higher loads to evaluate permanent deformation and the effects of cycling on modulus. The peak pressure shall be approximately 30, 60, and 100 % of the maximum. During each cycle, vary the pressure in at least five equal increments and five decrements. At the end of each cycle, return the pressure to the initial seating pressure.

11.7 *Test at Various Orientations*—If tests are desired in different orientations, it is preferable to move the jack at least 30.5 cm (12 in.) below or above the previous test location so as to provide an undisturbed site for testing. It is suggested that successive orientations be perpendicular to each other. It is recommended that the first test be conducted at the deepest location, and the following tests be at successively shallower depths to prevent possible borehole damage in a given test from interfering with subsequent testing.

11.8 *Indications of Time-Dependent Effects*—Determine time dependent deformation characteristics during the test by maintaining the maximum test pressure for 15 min and recording deformation at 5 min intervals. When the pressure is reduced to the initial seating pressure, take deformation readings again at 5 min intervals for 15 min. If at least three such determinations are made in a given rock material, and the deformation indicated by either LVDT changing by more than 5 % of the total accumulated deformation up to that stress level over the 15 min intervals in any of the tests, assume that the material exhibits time-dependent behavior at that stress level, and, follow by further investigation.

11.9 *Data Recording Requirements*—Record the data

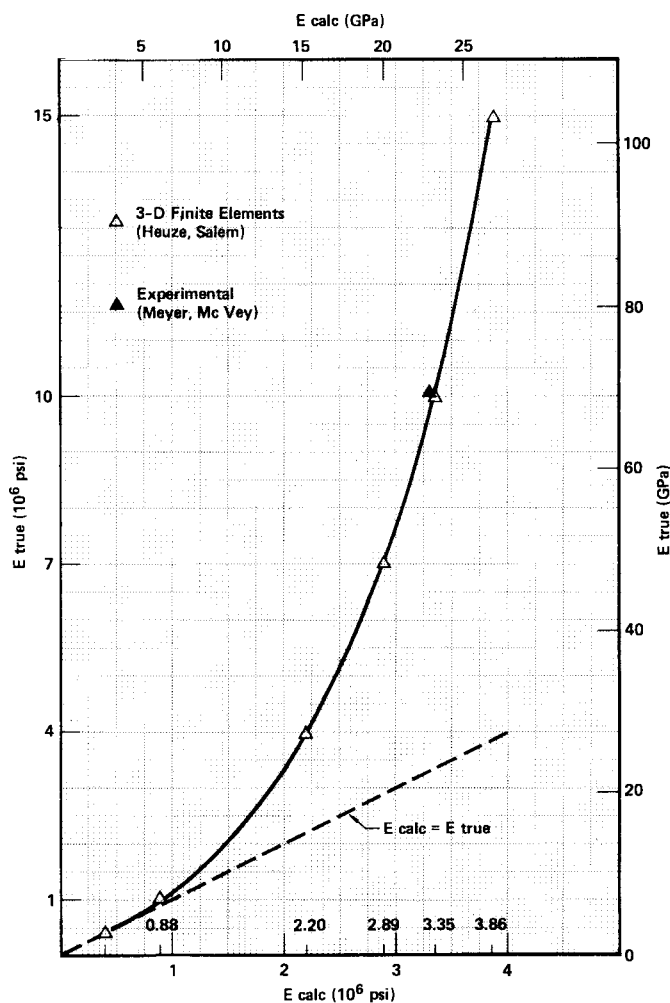

FIG. 5 Curve of $E_{theoretical}$ versus $E_{calc}(9, 10)$

may be added as appropriate, and the order of chapters may be changed as appropriate. Applications of test results are beyond the scope of this procedure, but may be an integral part of some testing programs. In that case an applications section compatible with the format described in this section should be included.

13.2 *Introductory Section*—The introductory section of the report is intended to present the scope and purpose of the testing program and the characteristics of the material tested.

13.2.1 The location and orientation of the test boreholes shall be presented. A graphic presentation is recommended. The reasons for selecting the test locations shall be recorded.

13.2.2 *Limitations of the Testing Program*—Areas of interest not covered by the testing program and the limitations of data within the area of application shall be discussed in general terms.

13.2.3 *Brief Description of Test Site Geology*—The rock type shall be described macroscopically from both field inspection and from the core logs of the test boreholes. Structural features affecting the borehole jack testing shall be discussed as appropriate. Available data on properties of rock cores that may aid in interpreting borehole jacking data shall be presented in the report. It should be indicated whether or not the tests were performed with the jack immersed in water.

13.2.4 *Equipment and Apparatus*—A detailed listing of the equipment actually used for the test shall be included in the report (jack, readout, box, and hydraulic system). The name, model number, serial number, and basic specifications of each major piece shall be listed.

13.2.5 *Procedure*—The procedure actually used for the test shall be listed in detailed steps.

13.2.6 *Variations*—If actual equipment or procedure varied from requirements contained in this test method, each variation and the reasons for it shall be noted. The effect of the variation upon test results shall be estimated.

13.3 Report the theoretical background as follows:

13.3.1 *Data Reduction Equations*—All equations used to reduce the data shall be clearly presented and fully defined. Any assumptions implicit in the equations, limitations in their application, and their effects on the results shall be noted.

13.4 Report site-specific influences as follows:

13.4.1 *Assumptions*—The degree to which actual test site conditions conform to assumptions in the data reduction equations.

13.4.2 *Correction Factors*—Any factors or methods applied to the data to correct for non-ideal situations shall be fully explained.

13.5 Present test results as follows:

13.5.1 *Summary Table*—A summary table shall be presented in which rock materials, the pressure range over which modulus values were calculated, mean modulus values, ranges, and uncertainties are shown.

13.5.2 *Table of Individual Results*—A table listing test number, rock material, structure, α , and average modulus values for each location shall be presented.

13.5.3 *Graphic Presentations*—A typical pressure versus deformation plot for each rock material shall be presented.

13.6 *Other*—The following types of analyses and presentations may be included as appropriate:

13.6.1 Relationship between modulus and applied pressure.

13.6.2 Discussions of modulus dependence on geology.

13.6.3 Histograms of results.

13.6.4 Comparison with laboratory modulus values or the results of other in situ modulus tests.

13.6.5 Comparison of results to other rock types of previous studies.

13.7 *Appended Data (Hole, Depth, Orientation)*—For each test, an appendix shall include a pressure versus deformation plot and a completed Test Data Sheet Form 1, (see Fig. 4).

14. Precision and Bias

14.1 No data comparable to those developed from an interlaboratory test program are available for this in situ test method. The variability of rock in situ and the resultant inability to determine a true reference value prevent development of a valid statement of bias. The subcommittee is seeking pertinent data from users of this test method to assist in estimating its precision.

14.2 Methods for determining inhomogeneity and anisotropy are discussed in Section 8.

14.3 The error associated with a single test can be assessed from data required in 13.5.1 and 13.5.2.

14.4 For each rock material or structure, the mean modulus



of deformation, range, and standard deviation can be determined from 12.1. The uncertainty of the group can be compared dependent upon items discussed in 13.6.

15. Keywords

15.1 anisotropy; borehole drilling; deformation; displacement; jack test; loading tests; modulus of deformation; orientation; pressure testing; rock

REFERENCES

- (1) Goodman, R. E., Van, T. K., and Heuze, F. E., "Measurement of Rock Deformability in Boreholes," *Proceedings of the 10th U.S. Symposium on Rock Mechanics*, University of Texas, Austin, TX, May 1970, pp. 523–555.
- (2) Heuze, F. E., "Scale Effects in the Determination of Rock Mass Strength and Deformability," *Rock Mechanics*, Vol. 12, 1980, pp. 167–192.
- (3) Heuze, F. E., and Amadei, B., "The NX-Borehole Jack: A Lesson in Trials and Errors," *International Journal of Rock Mechanics and Mining Sciences*, Vol. 22, April 1985, pp. 105–112.
- (4) Hustrulid, W. A., "An Analysis of the Goodman Jack," *Proceedings of the 17th U.S. Symposium on Rock Mechanics*, University of Utah, Salt Lake City, UT, 1976, pp. 4 B10-1–4 B10-8.
- (5) Shuri, F. S., "Borehole Diameter as a Factor in Borehole Jack Results," *Proceedings of the 22nd U.S. Symposium on Rock Mechanics*, MIT Press, Cambridge, MA, 1981, pp. 422–427.
- (6) Shuri, F. S., Feves, M. L., Peterson, G. L., Foster, K. M., and Kienle, C. F., *Field and In Situ Rock Mechanics Testing Manual*, ONWI-310. Office of Nuclear Waste Isolation, Battelle Memorial Institute, Columbus, OH, 1981.
- (7) Swolfs, H. S., and Kibler, J. D., "A Note on the Goodman Jack," *Rock Mechanics*, Vol. 15/2, 1982, pp. 57–66.
- (8) Patrick, W. C., Yow, J. L., Jr., and Axelrod, M. C., "Observations of Borehole Deformation Modulus Values Before and After Extensive Heating of a Granite Rock Mass," *Proceedings of the 26th U.S. Symposium on Rock Mechanics*, Balkema, A. A., Rotterdam, 1985, pp. 851–858.
- (9) Heuze, F. E., and Salem, A., "Rock Deformability Measured In Situ Problems and Solutions," *Proceedings International Symposium on Field Measurements in Rock Mechanics*, Zurich, Balkema, A. A., Rotterdam, 1977, pp. 375–387.
- (10) Meyer, T. O., and McVey, J. R., *NX-Borehole Jack Modulus Determinations in Homogenous, Isotropic, Elastic Materials*, U.S. Bureau of Mines, RI 7855. Washington, DC, 1974.

The American Society for Testing and Materials takes no position respecting the validity of any patent rights asserted in connection with any item mentioned in this standard. Users of this standard are expressly advised that determination of the validity of any such patent rights, and the risk of infringement of such rights, are entirely their own responsibility.

This standard is subject to revision at any time by the responsible technical committee and must be reviewed every five years and if not revised, either reapproved or withdrawn. Your comments are invited either for revision of this standard or for additional standards and should be addressed to ASTM Headquarters. Your comments will receive careful consideration at a meeting of the responsible technical committee, which you may attend. If you feel that your comments have not received a fair hearing you should make your views known to the ASTM Committee on Standards, at the address shown below.

This standard is copyrighted by ASTM, 100 Barr Harbor Drive, PO Box C700, West Conshohocken, PA 19428-2959, United States. Individual reprints (single or multiple copies) of this standard may be obtained by contacting ASTM at the above address or at 610-832-9585 (phone), 610-832-9555 (fax), or service@astm.org (e-mail); or through the ASTM website (www.astm.org).