



Standard Test Method for Heating Value of Gases in Natural Gas Range by Stoichiometric Combustion¹

This standard is issued under the fixed designation D 4891; the number immediately following the designation indicates the year of original adoption or, in the case of revision, the year of last revision. A number in parentheses indicates the year of last reapproval. A superscript epsilon (ε) indicates an editorial change since the last revision or reapproval.

^{ε1} NOTE—Section 11 was added editorially in July 1994.

1. Scope

1.1 This test method covers the determination of the heating value of natural gases and similar gaseous mixtures within the range of composition shown in Table 1.

1.2 *This standard involves combustible gases. It is not the purpose of this standard to address the safety concerns, if any, associated with their use. It is the responsibility of the user of this standard to establish appropriate safety and health practices and determine the applicability of regulatory limitations prior to use.*

2. Referenced Documents

2.1 ASTM Standards:

D 1826 Test Method for Calorific Value of Gases in Natural Gas Range by Continuous Recording Calorimeter²

E 691 Practice for Conducting an Interlaboratory Study to Determine the Precision of a Test Method³

3. Terminology

3.1 All of the terms defined in Test Method D 1826 are included by reference.

3.2 Descriptions of Terms:

3.2.1 *combustion ratio*—the ratio of combustion air to gaseous fuel.

3.2.2 *stoichiometric ratio*—the combustion ratio when the quantity of combustion air is just sufficient to convert all of the combustibles in the fuel to water and carbon dioxide.

3.2.3 *burned gas parameter*—a property of the burned gas after combustion which is a function of the combustion ratio.

3.2.4 *critical combustion ratio*—for a specific burned gas parameter, the combustion ratio at which a plot of burned gas parameter versus combustion ratio has either maximum value or maximum slope.

4. Summary of Test Method

4.1 Air is mixed with the gaseous fuel to be tested. The

TABLE 1 Natural Gas Components and Range of Composition Covered

Compound	Concentration Range, mole, %
Helium	0.01 to 5
Nitrogen	0.01 to 20
Carbon dioxide	0.01 to 10
Methane	50 to 100
Ethane	0.01 to 20
Propane	0.01 to 20
<i>n</i> -butane	0.01 to 10
isobutane	0.01 to 10
<i>n</i> -pentane	0.01 to 2
Isopentane	0.01 to 2
Hexanes and heavier	0.01 to 2

mixture is burned and the air-fuel ratio is adjusted so that essentially a stoichiometric proportion of air is present. More exactly, the adjustment is made so that the air-fuel ratio is in a constant proportion to the stoichiometric ratio which is a relative measure of the heating value. To set this ratio, a characteristic property of the burned gas is measured, such as temperature or oxygen concentration.

5. Significance and Use

5.1 This test method provides an accurate and reliable procedure to measure the total heating value of a fuel gas, on a continuous basis, which is used for regulatory compliance, custody transfer, and process control.

5.2 Some instruments which conform to the requirements set forth in this test method can have response times on the order of 1 min or less and can be used for on-line measurement and control.

5.3 The method is sensitive to the presence of oxygen and nonparaffin fuels. For components not listed and composition ranges that fall outside those in Table 1, modifications in the method may be required to obtain correct results.

6. Apparatus

6.1 A suitable apparatus for carrying out the stoichiometric combustion method will have at least the following four components: flow meter or regulator, or both; combustion chamber; burned gas sensor; and electronics. The requirement for each of these components is discussed below. The detailed design of each of these components can vary. Two different

¹ This test method is under the jurisdiction of ASTM Committee D-3 on Gaseous Fuels and is the direct responsibility of Subcommittee D03.03 on Determination of Heating Value and Relative Density of Gaseous Fuels.

Current edition approved Jan. 27, 1989. Published March 1989.

² *Annual Book of ASTM Standards*, Vol 05.05.

³ *Annual Book of ASTM Standards*, Vol 14.02.

apparatus are shown in Fig. 1 and Fig. 2. In each figure the equivalent of the four necessary components are enclosed in dashed lines.

6.2 *Overview*—Air and fuel enter the apparatus and the flow of each is measured. Alternatively, only one gas flow need be measured if the flow of the other is kept the same during measurement and calibration. This is illustrated in Fig. 2. Next there is a combustion chamber in which the air and fuel are mixed and burned. This can be as simple as a bunsen or meeker burner, but precautions should be taken that subsequent measurements of burned gas characteristics are not influenced by ambient conditions. Finally, there is a sensor in the burned gas which measures a property of this gas that is sensitive to the combustion ratio and has a unique feature at the stoichiometric ratio. Two such properties are temperature and oxygen concentrations, and either can be measured.

6.3 *Flow Meter and/or Regulator*—The flow measurement part of the apparatus should have an accuracy and precision of the order of 0.1 %. Likewise, if the flow is to be kept constant, the flow regulator should maintain this constant value within 0.1 %. The meter or regulator for natural gas must maintain this precision and accuracy over the density and viscosity ranges consistent with the composition range in Table 1.

6.4 *Combustion Chamber:*

6.4.1 There are two different types of combustion chambers that may be used. In the first type the air and fuel are mixed and burned in a single burner. The apparatus shown in Fig. 1 has this type of combustion chamber.

6.4.2 In the second type of combustion chamber, the air and fuel are each divided into two streams, and combustion takes place simultaneously in two burners. The division of air flow must be such that the proportion of air going to each burner always remains the same. Likewise the division of fuel flow must always remain the same even through fuel composition changes. Another requirement is that the flow divisions be such that one burner has a mixture with a slightly higher combustion ratio than the other. The apparatus shown in Fig. 2 has this type of combustion chamber.

6.5 *Burned Gas Sensor:*

6.5.1 The burned gas sensor must measure a characteristic of the burned gas which is a function of the combustion ratio and for which there is a critical combustion ratio related to the stoichiometric ratio. A combustion chamber of the first type

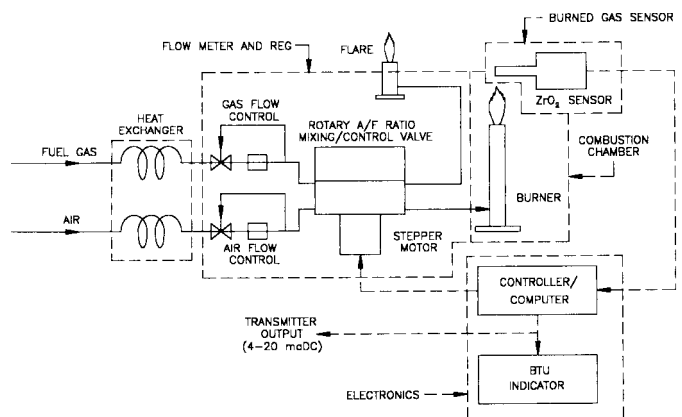

FIG. 1 Gas Btu Transmitter (Functional Overview)

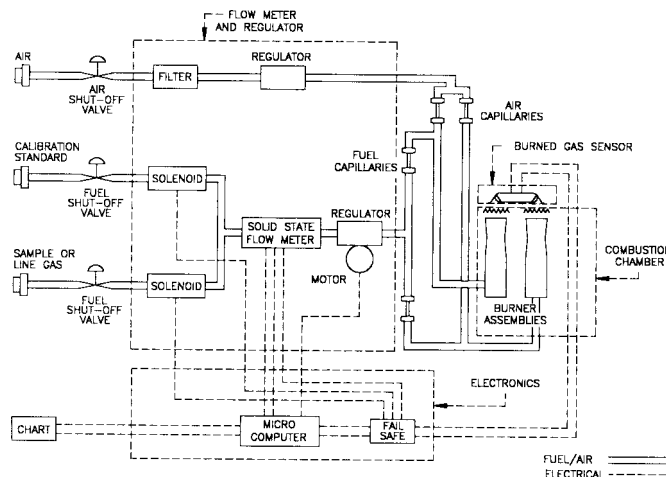

FIG. 2 Stoichiometric Combustion Apparatus

(Fig. 1) would have one sensor in the burned gas and its output signal would constitute the desired measurement. In a combustion chamber of the second type (Fig. 2) there would be a sensor in the burned gas from each burner. The difference between the two output signals would constitute the desired measurement.

6.5.2 There are several properties of the burned gas which are related uniquely to the combustion ratio. A burned gas sensor may be selected which provides a measure of any one of these, for example, either temperature or oxygen partial pressure.

6.6 *Electronics*—Electronics are used to receive the signals from the components described above to control the flow of gases into the combustion chamber in response to the signal from the burned gas sensor and to provide a digital or analog output signal, or both, which is proportional to the heating value of the gaseous fuel.

6.7 *Temperature Stability and Operating Environment*—The method is capable of operating over a range of temperatures limited only by the specific apparatus used to realize the method. It is desirable to equilibrate the air and fuel temperatures before the gases are measured. The electronics should also be stabilized against temperature changes and the burned gas sensor should be insensitive to changes in the ambient conditions.

7. Reagents and Materials

7.1 *Physical Contamination*—The air and gas must be free of dust, liquid, water, liquid hydrocarbons, and other entrained solids. Foreign materials should be removed by a sample line filter. To avoid any problems in the line from any liquid accumulation, pitch the line to a low point and provide a drip leg.

7.2 *Chemical Contamination*—The air must be free of combustible compounds. The oxygen content and the absolute humidity of the air should be the same during measurement as during calibration.

8. Calibration and Standardization

8.1 The calibration factor, F , and the constant, B , in the equation, $C = F \cdot R + B$, are determined through an initial

calibration, in which the critical combustion ratios of at least two standard gases of known but different heating values are measured using the procedure described in 9.1.

8.2 The calibration factor, F , is routinely redetermined at regular intervals under field conditions using a calibration gas of known heating value. The constant, B , is not adjusted in the routine calibrations. The interval between routine calibrations must be determined under the specific operating conditions, and is usually of the order of 24 h. Determination of F establishes the amount of net oxygen per standard volume of combustion air. Variations in net oxygen constant can be caused by several factors, such as changes in absolute humidity or the presence of contaminants in the air supply.

9. Procedure

9.1 Measure the burned gas parameter at different combustion ratios and determine that combustion ratio for which the parameter has a specified characteristic such as a maximum, minimum, or maximum rate of change.

9.1.1 Use an apparatus such as in Fig. 1 or Fig. 2 where the components of the apparatus meet the requirements of Section 6. If the apparatus has two flow meters, the combustion ratio is the ratio of the output of the air flow meter divided by the output of the fuel flow meter. If the apparatus has only one flow meter, then the combustion ratio is set numerically equal to either the output of the air flow meter or the reciprocal of the output of the fuel flow meter. The burned gas parameter is a function of the combustion ratio and is measured at different combustion ratios. The critical combustion ratio, R , is taken as that point where this function has a maximum value, minimum value, or maximum rate of change. The heating value, C , is calculated from the equation

$$C = F \cdot R + B, \quad (1)$$

where the constants B and F are determined as described in 8.1 and 8.2.

9.1.2 This procedure may be automated, for example, by using a microprocessor in the electronics.

9.2 For making laboratory measurements of highest precision, use the following procedure:

9.2.1 First calibrate the instrument as described in 8.2. Then, before measuring the test gases, measure two other standard gases of known heating value. After the test gas measurements, measure the two standard gases again. The known heating values of these standard gases, CAL.VAL.LOW and CAL.VAL.HIGH, should bracket that of the unknown gas. Combine the measured values of the standard gases and the test gases to obtain a best estimate of the heating value of the test gas. Do this using the following calculation procedure.

9.2.1.1 *Step 1*—There are four measured values for the calibration gases, two for the high calorific gas and two for the low calorific gas. Average these four measurements together. The result is represented by the symbol, AV.STD.GASES.

9.2.1.2 *Step 2*—Average the two known heating values of the standard gases together. The result is represented by the symbol, AV.CAL.VAL. Thus, AV.CAL.VAL = [(CAL.VAL.HIGH) + (CAL.VAL.LOW)]/2.

9.2.1.3 *Step 3*—Calculate a correction to the test gas mea-

surements. This correction is represented by the symbol, CORR. The calculation is as follows: CORR = (AV.STD.GASES) – (AV.CAL.VAL).

9.2.1.4 *Step 4*—Subtract the quantity, CORR, that is calculated in Step 3 from each of the test gas measurements to give the corrected value.

9.2.2 *Example 1*—Standard gas low has CAL.VAL.LOW = 1000 Btu/standard cubic foot and measured values after calibration are 1002.0 and 1002.8. (All heating values in Example 1 and Example 2 have units of Btu per standard cubic foot.) Standard gas high has CAL.VAL.HIGH = 1200 and measured values of 1202.0 and 1203.2.

$$\begin{aligned} \text{AV.STD.GASES} &= (1002.0 + 1002.8 + 1202.0 + 1203.2)/4 \\ &= 1102.5. \end{aligned}$$

$$\text{AV.CAL.VAL} = (1000.0 + 1200.0)/2 = 1100.0$$

$$\text{CORR} = 1102.5 - 1100 = 2.5$$

$$\text{TEST GAS MEASUREMENT} = 1080.6$$

$$\text{CORRECTED VALUE} = (1080.6 - 2.5) = 1078.1$$

9.2.3 *Example 2*:

CAL.VAL.LOW = 1000 Btu/standard cubic foot.

Measured values are 998.0 and 998.2.

CAL.VAL.HIGH = 1200

Measured values are 1199.0 and 1199.2

$$\begin{aligned} \text{AV.STD.VAL} &= (998.0 + 998.2 + 1199.0 + 1199.2)/4 = \\ &1098.6 \end{aligned}$$

$$\text{AV.CAL.VAL} = 1100$$

$$\text{CORR} = (1098.6 - 1100) = 1.4$$

$$\text{TEST GAS MEASUREMENT} = 1076.7$$

$$\text{CORRECTED VALUE} = [1076.7 - (-1.4)] = 1078.1$$

10. Precision and Bias

10.1 To determine precision and bias, an interlaboratory study was carried out using two types of commercial instruments that implement the stoichiometric method. For each type of instrument six different laboratories each measured five different reference gases. Cylinders containing these reference gases were transported from laboratory to laboratory. Each laboratory used its own instrument and personnel to measure the heating values of the gases in these cylinders. The same calibration gas was used to calibrate each instrument.

10.2 The heating values of the reference gases were determined prior to the study by the Institute of Gas Technology. These values were established by averaging three recording calorimeter measurements. The values were unknown to the participants in the interlaboratory test program. At the end of the study, the heating values were remeasured at the Institute of Gas Technology to establish that the gas compositions did not change. The statistical analysis of the results was in accordance with the procedures in Practice E 691.

10.2.1 *Repeatability*—The root mean square estimate of the within laboratory component of standard deviation was 0.76 Btu/standard cubic foot. The corresponding 95 % confidence repeatability interval was 2.1 Btu/standard cubic foot.

10.2.2 *Reproducibility*—The root mean square estimate of the between laboratory component of standard deviation was 1.67 Btu/standard cubic foot. The corresponding 95 % confidence reproducibility interval was 5.1 Btu/standard cubic foot.

10.2.3 *Bias*—The average of all measurements agreed with the average reference value within 0.1 %.

11. Keywords

11.1 natural gas range by stoichiometric conversion

The American Society for Testing and Materials takes no position respecting the validity of any patent rights asserted in connection with any item mentioned in this standard. Users of this standard are expressly advised that determination of the validity of any such patent rights, and the risk of infringement of such rights, are entirely their own responsibility.

This standard is subject to revision at any time by the responsible technical committee and must be reviewed every five years and if not revised, either reapproved or withdrawn. Your comments are invited either for revision of this standard or for additional standards and should be addressed to ASTM Headquarters. Your comments will receive careful consideration at a meeting of the responsible technical committee, which you may attend. If you feel that your comments have not received a fair hearing you should make your views known to the ASTM Committee on Standards, 100 Barr Harbor Drive, West Conshohocken, PA 19428.

This standard is copyrighted by ASTM, 100 Barr Harbor Drive, West Conshohocken, PA 19428-2959, United States. Individual reprints (single or multiple copies) of this standard may be obtained by contacting ASTM at the above address or at 610-832-9585 (phone), 610-832-9555 (fax), or service@astm.org (e-mail); or through the ASTM website (<http://www.astm.org>).