



Designation: D 1043 – 9902

An American National Standard

Standard Test Method for Stiffness Properties of Plastics as a Function of Temperature by Means of a Torsion Test¹

This standard is issued under the fixed designation D 1043; the number immediately following the designation indicates the year of original adoption or, in the case of revision, the year of last revision. A number in parentheses indicates the year of last reapproval. A superscript epsilon (ϵ) indicates an editorial change since the last revision or reapproval.

This standard has been approved for use by agencies of the Department of Defense.

1. Scope*

1.1 This test method covers the determination of the stiffness characteristics of plastics over a wide temperature range by direct measurement of the apparent modulus of rigidity.

1.2 The values stated in SI units are to be regarded as the standard. The values given in parentheses are for information only.

1.3 *This standard does not purport to address all of the safety concerns, if any, associated with its use. It is the responsibility of the user of this standard to establish appropriate safety and health practices and determine the applicability of regulatory limitations prior to use.*

NOTE 1—This test method is not equivalent to ISO 458/1:1985 or ISO 458/2:1985 and results cannot be directly compared between the two methods.

2. Referenced Documents

2.1 *ASTM Standards:*

¹ This test method is under the jurisdiction of ASTM Committee D-20 on Plastics and is the direct responsibility of Subcommittee D20.10 on Mechanical Properties. Current edition approved April 10, ~~1999~~, 2002. Published ~~July 1999~~, June 2002. Originally published as D 1043 – 49. Last previous edition D 1043 – 929.

***A Summary of Changes section appears at the end of this standard.**

- D 618 Practice for Conditioning Plastics for Testing²
- D 638 Test Method for Tensile Properties of Plastics²
- D 747 Test Method for Apparent Bending Modulus of Plastics by Means of a Cantilever Beam²
- D 883 Terminology Relating to Plastics²
- D 1053 Test Method for Rubber Property—Stiffening at Low Temperatures: Flexible Polymers and Coated Fabrics³
- D 4000 Classification System for Specifying Plastic Materials⁴
- D 4066 SpecClassification System for Nylon Injection and Extrusion Materials⁴
- D 4805 Terminology of for Plastics Standards⁵

3. Terminology

3.1 *Definitions*—For definitions of the technical terms pertaining to plastics used in this test method, see Terminology D 883 or Terminology D 4805.

4. Significance and Use

4.1 The property measured by this test is the apparent modulus of rigidity, G , sometimes called the apparent *shear* modulus of elasticity. It is important to note that this property is not the same as the modulus of elasticity, E , measured in tension, flexure, or compression. The relationship between these properties is shown in Annex A1.

4.2 The measured modulus of rigidity is termed “apparent” since it is the value obtained by measuring the angular deflection occurring when the specimen is subjected to an applied torque. Since the specimen may be deflected beyond its elastic limit, the calculated value may not represent the true modulus of rigidity within the elastic limit of the material. In addition, the value obtained by this test method will also be affected by the creep characteristics of the material, since the load application time is arbitrarily fixed. For many materials, there may be a specification that requires the use of this test method, but with some procedural modifications that take precedence when adhering to the specification. Therefore, it is advisable to refer to that material specification before using this test method. Table 1 in Classification D 4000 lists the current ASTM materials standards.

4.3 This test method is useful for determining the relative changes in stiffness over a wide range of temperatures.

5. Apparatus

5.1 *Testing Machine*—A machine capable of exerting a torque sufficient to deflect a test specimen in the range of 5 to 100° of arc, depending on the stiffness of the specimen and its span. A schematic diagram of a suitable machine is shown in Fig. 1.

NOTE 2—Two machines of different torque capacities are being used: one covers the range of approximately 0.0113 to 0.113 N·m (0.1 to 1.0 in·lbf) and the other of approximately 0.113 to 1.81 N·m (1.0 to 16 in·lbf) or higher. Some machines also allow varying the span, which is especially important if shearing failures can occur (as in laminates at a span/width of 6).

NOTE 3—The amount of torque may be varied to suit the stiffness of the test specimen, and various weights should be available for this purpose. The actual amount of torque being applied by any given combination of weights, torque wheel radii, and shaft bearings should be determined by calibration. The accuracy of the apparatus can be subject to change, and therefore periodic calibration is necessary to ensure reliable test results. Testing machine calibration procedures are given in Annex A2 and Annex A3.

NOTE 4—For operation at low temperatures the shaft of the machine must be provided with a heated collar next to the lower bearing to prevent the formation of ice.

5.2 Temperature Control:

5.2.1 *Flask*—A Dewar flask of suitable dimensions.

5.2.2 *Thermometer*—A thermometer graduated in 1°C divisions and having the necessary range. The bulb shall be located in close proximity to the test specimen. A digital-readout RTD thermometer having an accuracy of $\pm 1^\circ\text{C}$ or better may be used.

5.2.3 *Timer*, for controlling load application time.

5.2.4 *Heat-Transfer Medium*—For normal laboratory purposes, a substance that is liquid over the desired temperature range shall be used for the heat-transfer medium, provided it has been shown that the liquid does not soften or otherwise affect the test specimen.

NOTE 5—Among the liquids found useful are acetone, ethanol, butanol, methanol, normal hexane, silicone oil, and a mixture of methyl phosphate and water in the ratio of 87 to 13 by volume. For temperatures to -70°C (-94°F), a mixture of 50 parts ethanol, 30 parts ethylene glycol, and 20 parts water may be found useful.

5.2.5 *Refrigeration*—Means shall be provided for cooling the heat-transfer medium. This cooling can be by means of a refrigeration cooling coil built into the instrument and immersed in the Dewar flask of heat transfer fluid or by means of a low temperature chamber in which Dewar flasks of heat transfer liquid are placed to pre-cool before starting the test.

NOTE 6—For time-efficient low-temperature use of the equipment, space for cooling enough containers of the heat-transfer medium for a day’s work is desirable. Depending on the temperature ranges involved, mechanical refrigeration or a dry-ice chest, or both, will be advantageous.

² Annual Book of ASTM Standards, Vol 08.01.

³ Annual Book of ASTM Standards, Vol 09.01.

⁴ Annual Book of ASTM Standards, Vol 08.02.

⁵ Annual Book of ASTM Standards, Vol 08.03.

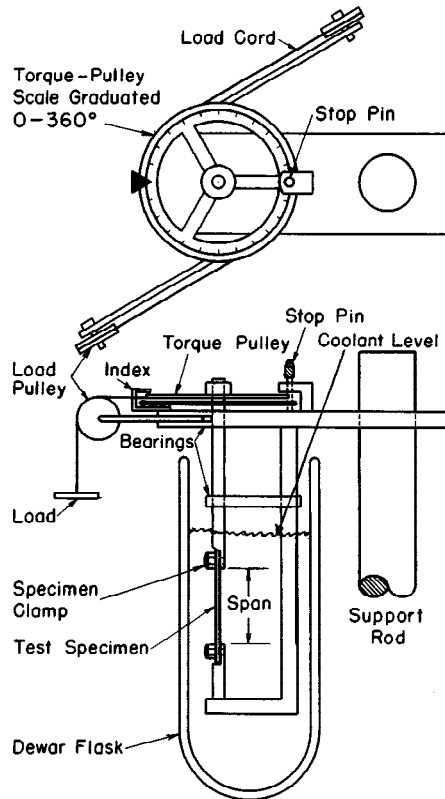

FIG. 1 Torsion Tester

5.2.6 *Heater*—A controlled electric immersion heater in the Dewar flask shall be used in conjunction with an agitator to vary the temperature.

5.3 *Micrometer*—A micrometer accurate to within ± 0.0025 mm (± 0.0001 in.) or better shall be used for measuring specimen thickness and width.

5.4 *Modifications to Testing Equipment*—The modifications described in Annex A4 will increase the accuracy and sensitivity of the testing equipment. The modifications are readily adaptable to several types of test equipment used for testing plastics. Some of the modifications are desirable, but not a necessity, for obtaining meaningful data.

6. Test Specimens

6.1 *Geometry*—Test specimens shall be of the rectangular geometry shown in Fig. 2. They may be cut from compression-molded sheets, extruded sheet, or from parts of uniform thickness having flat parallel surfaces. The specimens may also be injection molded. Care shall be taken to ensure that the test specimens are isotropic. Where the testing machine permits varying the span, the span to width (L/a) ratio should be 6 to 8. It is recommended that spans of 38 to 100 mm (1.5 to 4 in.) be used. The specimen may be used for nonrigid materials on the low-range machine which has a span (L) of 38 mm (1.5 in.).

6.2 *Thickness*—The thickness of the specimen may vary between approximately 1 and 3 mm (0.040 and 0.125 in.). This range normally makes it possible to test materials of widely different stiffnesses.

6.3 Duplicate specimens of each material shall be tested. More replications are often needed, especially for nonhomogeneous materials. If the results from testing the first two specimens differ significantly, test a third specimen and discard the outlier (the value that varies the most from the other two).

7. Conditioning

7.1 *Conditioning*—For those tests where conditioning is required, condition the test specimens at $23 \pm 2^\circ\text{C}$ ($73.4 \pm 3.6^\circ\text{F}$) and $50 \pm 5\%$ relative humidity for not less than 40 h prior to testing in accordance with Procedure A of Practice

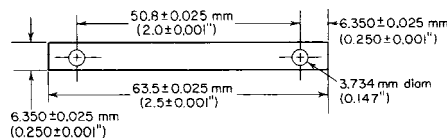

FIG. 2 Test Specimen

~~D 618. In cases of disagreement, D 618 unless otherwise specified by contract or the relevant ASTM material specification. Reference pre-test conditioning, to settle disagreements, shall apply tolerances of $\pm 1^\circ\text{C}$ ($\pm 1.8^\circ\text{F}$) and $\pm 2\%$ relative humidity.~~

~~7.1.1 Note that for some hygroscopic materials, such as nylons,~~

~~7.2 Test Conditions—Conduct the material specifications (for example, Specification D 4066) call for testing “dry as-molded specimens.” Such requirements take precedence over the above routine preconditioning tests at $23 \pm 2^\circ\text{C}$ ($73.4 \pm 3.6^\circ\text{F}$) and $50 \pm 5\%$ relative humidity and require sealing unless otherwise specified by contract or the specimens in water vapor-impermeable containers as soon as molded relevant ASTM material specification. Reference testing conditions, to settle disagreements, shall apply tolerances of $\pm 1^\circ\text{C}$ (1.8°F) and not removing them until ready for testing. $\pm 2\%$ relative humidity.~~

8. Procedure

8.1 Measure the width and thickness of the specimen to three significant digits.

8.2 Carefully mount the specimen in the apparatus. Adjust the clamps so that the specimen is not under compression or tension and is in complete contact with the clamp's internal surfaces.

8.3 Place the thermometer in position with its bulb or sensing tip in close proximity to the test specimen.

8.4 Fill the Dewar flask with the heat-transfer medium. The heat-transfer medium may be precooled to a temperature lower than the lowest desired test temperature.

8.5 Place the flask in position on the instrument, and start the agitator.

8.6 By intermittent use of the immersion heater, bring the bath to the desired test temperature. This heating can be controlled by an automatic temperature controller, if the instrument is so equipped.

8.7 Condition the specimen at the test temperature for a minimum of 3 min.

8.8 Release the torque pulley. After 5 s note the angular deflection of the pulley and return the torque pulley to its initial position. If the reading thus obtained does not fall within the range from 5 to 100° of arc, vary the applied torque in such a way as to produce such a reading. For nonrigid materials, this reading should fall between 10 and 100° . If it necessary to vary the applied torque, wait another 3 min. and repeat the procedure at the same temperature.

NOTE 7—In order to obtain measured values of apparent modulus of rigidity, G , that are comparable to the true value of G , it is desirable that measurements be made within the elastic limit of the material being tested. Therefore, torques shall be chosen that will cause deflections that are as small as practical to measure accurately on the machine being used. It is often desirable to reduce the torque slightly before taking successive readings, particularly in the temperature range where the material is rapidly decreasing in rigidity.

NOTE 8—Better reproducibility is obtained if torques are chosen such that the deflection obtained at a given temperature is similar to or greater than that obtained at the previous lower temperature.

8.9 After each suitable reading is obtained, repeat the steps indicated in 8.6-8.8 for the next desired temperature. The torque may be lowered prior to each reading, if desired (Note 7 and Note 8).

9. Calculation

9.1 Calculate the apparent modulus of rigidity, G , for each temperature as follows:

$$G = 917 TL/ab^3u\phi \quad (1)$$

where:

G = apparent modulus of rigidity, Pa (or psi),

T = applied torque, N·m (or in·lbf),

L = specimen length (span), mm (or in.),

a = specimen width (larger cross-sectional dimension), mm (or in.),

b = specimen thickness (smaller cross-sectional dimension), mm (or in.),

ϕ = angle of deflection of torque pulley, degrees, and

u = value depending on the ratio of a to b . Table 1 gives the values of u for various ratios of a to b . A third column gives thickness if the width is 6.350 mm (0.250 in.). If Table 1 is not adequate, u may be calculated by means of the equation given in Annex A1.

9.2 Plot the apparent modulus of rigidity values, calculated in accordance with 9.1, on a logarithmic scale versus temperature on a linear scale.

9.3 If desired, read from the graph the temperature at which the apparent modulus of rigidity is equal to a specific value, such as 68.95 MPa, 241.3 MPa, 310.3 MPa, or 930.8 MPa (10 000 psi, 35 000 psi, 45 000 psi, or 135 000 psi). The temperature at which the apparent modulus of rigidity is equal to 310 MPa (45 000 psi) has been designated T_F (see Note A1.1).

NOTE 9—If the increments of temperature change used in the test are relatively small (for example about 3°C or 5°F) it may be possible to interpolate between test points to determine the temperature for a specific apparent modulus of rigidity, such as 310.3 MPa or 45 000 psi. However, this interpolation should be done on a semi-log basis to be approximately equivalent to the results of the semi-log plot. That is, the log of the modulus must be used to interpolate between the test temperatures, using the following formula, which is an example for interpolating to determine the T_F (310 MPa or 45 000 psi).

$$T_F = T_1 + \frac{(T_2 - T_1) X (\log G_{T_1} - \log 45000)}{(\log G_{T_1} - \log G_{T_2})} \quad (2)$$

TABLE 1 Values for u^A

Ratio of Width, a , to Thickness, b	u	Thickness when Width is 6.350 mm (0.250 in.)
2.00	3.66	3.175 mm (0.125 in.)
2.25	3.84	2.819 mm (0.111 in.)
2.50	3.99	2.540 mm (0.100 in.)
2.75	4.11	2.311 mm (0.091 in.)
3.00	4.21	2.108 mm (0.083 in.)
3.50	4.37	1.829 mm (0.072 in.)
4.00	4.49	1.600 mm (0.063 in.)
4.50	4.59	1.422 mm (0.056 in.)
5.00	4.66	1.270 mm (0.050 in.)
6.00	4.77	1.067 mm (0.042 in.)
7.00	4.85	0.914 mm (0.036 in.)

^A Taken from Trayer and March, *Report 334*, National Advisory Committee for Aeronautics, 1929.

where:

T_1 = lower of the two test temperatures,

T_2 = higher of the two test temperatures,

G_{T1} = apparent modulus of rigidity at temperature T_1 , psi, and

G_{T2} = apparent modulus of rigidity at temperature T_2 , psi.

10. Report

10.1 Report the following information:

10.1.1 Complete identification of the material, including name, stock or code number, date made, form, etc.,

10.1.2 Dimensions of the test specimen,

10.1.3 Details of conditioning the specimen prior to testing,

10.1.4 Identification of the heat transfer medium used,

10.1.5 Table of data and results,

10.1.6 Plot of logarithm of apparent modulus of rigidity *versus* temperature,

10.1.7 The temperature at the specified apparent modulus of rigidity values, if desired (see 9.3), and

10.1.8 Date of test.

11. Precision and Bias

11.1 Limited precision information is available from one laboratory testing a flexible vinyl material (plasticized PVC) to determine the temperature at which the apparent modulus of rigidity, G , is equal to 241.3 MPa (35 000 psi). Based on this data, the repeatability r is approximately $\pm 2^\circ\text{C}$ for a material with a mean value of -35.7°C ($r = 2.83 X$ standard deviation, see Practice E 177).

12. Keywords

12.1 Clash-Berg; modulus of rigidity; plastics; shear; torsion

ANNEXES

A1. CALCULATIONS

A1.1 Calculation of Factor u

A1.1.1 The factor u may be calculated by the following equation:

$$u = 5.33 - [(3.36 b/a)(1 - (b^4/12a^4))] \quad (\text{A1.1})$$

where:

u = factor depending on the ratio of a to b ,

a = specimen width, mm (or in.), and

b = specimen thickness, mm (or in.).

A1.2 Calculation of Apparent Modulus of Elasticity

A1.2.1 The relationship between modulus of rigidity, G , and modulus of elasticity, E , is expressed by the following equation (λ = Poisson's ratio):

$$E = 2G(1 + \lambda) \tag{A1.2}$$

A1.2.2 It has been shown for some highly extensible plastics that the value for E calculated from the above equation agrees well with experimental values obtained by Test Method D 747, when Poisson’s ratio is assumed to be 0.5, a suitable value for soft rubber at room temperature. It must be emphasized, however, that this is an experimental correlation only.

NOTE A1.1—Because of the correlation between E obtained from this test method and stiffness from Test Method D 747, values in the literature have frequently been given in terms of E when this test method has been used. In this case, where Poisson’s ratio is assumed to be 0.5, T_F indicates that temperature at which the material exhibits a modulus of elasticity, E , of 930.65 MPa (135 000 psi). The term T_4 has been used to indicate the temperature at which the modulus of elasticity is 68.95 MPa (10 000 psi).

A1.2.3 In general, the calculation of modulus of elasticity from data obtained in this test method is *not* recommended since there is evidence that suggests that Poisson’s ratio varies from material to material and may vary from temperature to temperature for the same material. In addition, data from the test may be obtained at deflections outside of the elastic limit of the material and thus would give misleading values of E . A value of modulus of elasticity may be obtained in tension as described in Test Method D 638.

A2. SETUP AND CALIBRATION PROCEDURE OF TORSIONAL-STIFFNESS APPARATUS BY COMPARING THE MEASURED TORQUE APPLIED AGAINST A CALIBRATED WIRE STANDARD

A2.1 *Apparatus*—Analytical balance, calipers, accurate to 0.1 mm (or equivalent measuring device), stop watch, and standard torsion wire. Construct a standard torsion wire by cutting a piece of tempered spring wire 45 mm (1.75 in.) long. This wire should be similar in dimensions and stiffness to the 2.0 gf·cm per degree of twist wire described in Test Method D 1053. Flatten slightly approximately 2 mm (0.062 in.) of each end of the wire and insert in the end holes of two brass mounting lugs so that exactly 38.1 mm (1.50 in.) of wire is exposed between the lugs (see Fig. A2.1). Squeeze the brass lugs with a hydraulic press so that they grip the wire firmly. The lugs shall be made of brass 6.4 by 12.7 by 3.2 mm (0.25 by 0.50 by 0.13 in.) with a 3.73-mm (0.147-in.) diameter hole in the middle of the lugs and a hole centered in one end slightly larger than the diameter of the spring wire.

A2.2 *Procedure*—Determine the following (see Fig. 1):

A2.2.1 The mass (to the nearest 0.1 mg) of each of the loads used to apply the torques,

A2.2.2 The diameter of the torque pulley of the apparatus to the nearest 0.1 mm (0.004 in.); if the grooves are cut in the pulley for the load cords, measure the diameter in the grooves,

A2.2.3 The diameter of the load cord used to the nearest 0.1 mm (0.004 in.), and

A2.2.4 The exact torques in N·m (in·lbf) for each of the applied torques 0.012 to 0.12 N·m (0.1 to 1 in·lbf) from the following equations:

A2.2.4.1 $R = (\text{diameter of the torque pulley} + \text{diameter of the load cord}) \div 2$, and

A2.2.4.2 Exact torques in N·m (in·lbf):

$$\begin{aligned} T_{0.0113} &= R \Sigma W_{0.0113} \\ T_{0.0226} &= R \Sigma W_{0.0226} \\ T_{0.113} &= R \Sigma W_{0.113} \end{aligned} \tag{A2.1}$$

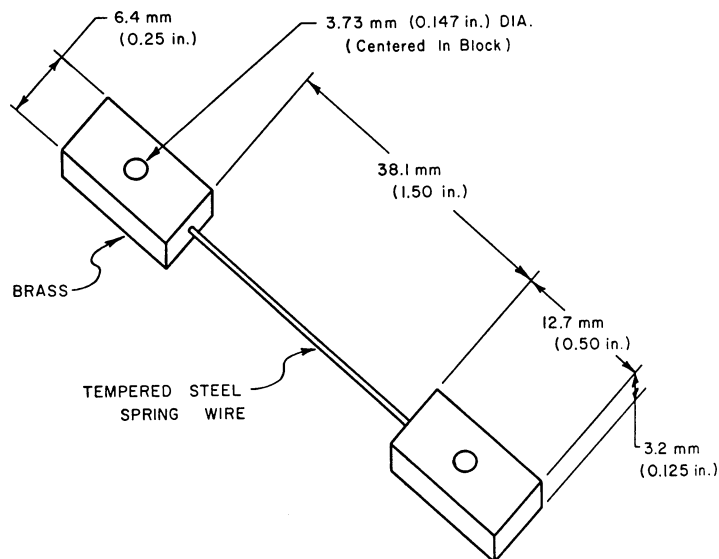

FIG. A2.1 Standard Wire

where:

- R = effective radius, mm (in.),
- $\Sigma W_{0.0113}$ = sum of weights in kg (lb) used to apply a torque of 0.0113 N·m (0.1 in.·lbf), and
- $\Sigma W_{0.0226}$ = sum of the weights in kg (lb) used to apply a torque of 0.0226 N·m (0.2 in.·lbf), etc. through $\Sigma W_{0.0113}$ N·m (1.0 in.·lbf),
- $\text{N}\cdot\text{m} \div 0.1129848$ = in.·lbf, and
- $\text{in.}\cdot\text{lbf} \times 0.1129848$ = N·m.

A2.2.5 Calibrate the torsion wire in accordance with the following procedure of Test Method D 1053.

A2.2.5.1 Insert one end of the torsion wire in a vertical position into a fixed clamp and attach the lower end of the wire at the exact longitudinal center of a rod of known dimensions and weight. It is suggested that the rod be 200 to 250 mm (8 to 10 in.) long and about 6 mm (0.25 in.) in diameter (see Fig. A2.2 for recommended dimensions to use for standardization purposes). The rod should be twisted (not more than 90°) and then released. The rod should be allowed to oscillate freely in a horizontal plane and the time required for 20 oscillations noted in seconds. (An oscillation includes the swing from one extreme to the other and return.)

A2.2.5.2 Calculate the mass moment of inertia, as follows:

$$I = mL^2/12 \text{-----} \text{(A2.2)}$$

where:

- I = moment of inertia, g·cm²,
- m = mass, g, and
- L = length, cm.

A2.2.5.3 Calculate the torsional constant as follows:

$$\lambda = 4\pi^2 I/T^2 \text{-----} \text{(A2.3)}$$

where:

- λ = torque exerted by the wire, N·m per radian of twist,
- T = period of one oscillation, s, and
- I = moment of inertia of the rod, g·cm².

A2.2.6 Mount the standard wire, in the equipment to be tested, in such a manner that the degrees of twist at zero load is zero. Apply 0.0113 N·m (0.1 in.·lbf) torque and release the torque pulley slowly. Record the dial reading in degrees. Move the torque pulley slightly above the reading and release. Record reading again. Move the torque pulley slightly below the reading and release. Record reading again. The dial readings recorded should agree to within 0.5° (Note A2.1). Record the average of the readings (θ) of degrees of twist at 0.0113 N·m (0.1 in.·lbf) torque.

NOTE A2.1—If the torque pulley does not oscillate freely and reproduce readings, the condition of the bearings and alignment of the pulley should be checked to eliminate any friction. The ball bearings can be cleaned with carbon tetrachloride, dried completely and lubricated with a few drops of a 1:10 mixture of light lubricating oil dissolved in carbon tetrachloride. Another alternative is to check Annex A4 on modifications to reduce friction in the system.

A2.2.7 Calculate the N·m (in.·lbf) torque from the product of the torsional constant (K') and the degrees of twist (θ) as shown in Table A2.1. This value should equal the actual load to within less than 0.5 %. Table A2.1 shows the results obtained on three instruments.

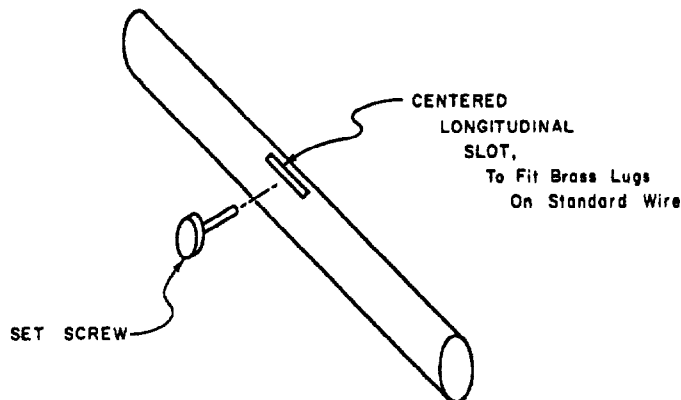

6.35 mm (0.25 in.) Diameter by 200 mm (7.875 in.) LG Brass Rod

FIG. A2.2 Calibration Rod

TABLE A2.1 Example of Calibration of Three Clash-Berg Type Instruments

	Instrument No.		
	I	II	III
Applied torques, lbf-in.	0.1	0.1	0.1
Actual torque <i>T</i> 0.1 lbf-in.	0.09916	0.09603	0.1294
Torsional constant of wire <i>K'</i> (lbf-in.) = 0.002532			
Degrees twist (θ)	39	38	51
Calculated torque ($K' \times \theta$)	0.09877	0.09624	0.1292
Percent error ^A	0.39	0.21	0.20

^A $[(\text{Actual torque} - \text{Calculated torque}) / \text{Applied torque}] \times 100.$

A3. SETUP AND CALIBRATION PROCEDURE OF TORSIONAL-STIFFNESS APPARATUS WHERE THE USE OF ANY MECHANICAL SYSTEMS OTHER THAN THOSE NECESSARY TO THE NORMAL FUNCTION- OF- THE- APPARATUS- DURING- USE- IS- ELIMINATED

NOTE A3.1—This calibration procedure applies to a Clash-Berg type apparatus as shown in Fig. A3.1.

A3.1 This is accomplished by having the weights on the two load pans act as opposing forces on the main torque pulley. With this arrangement, one of the loads would function as input (applied load) while the other would act as output (calibration load). Calibration, therefore, would be dependent only upon structural-design characteristics inherent in the test apparatus.

A3.2 To have the loads act as opposing forces, it is necessary to remove the left load pulley and shaft from the rear of the stirrer motor-housing frame and remount it on the front left frame so that the load-pan supporting cord can have an unobstructed path to the main torque pulley. To do this, a hole, the proper diameter of the pulley-shaft, is drilled at the same height and parallel to the existing pulley-shaft hole. When the left load pulley and shaft are mounted in the front position, the load-pan supporting cord is wound around the main torque pulley in such a manner that an applied force would oppose that of the right load pan. It is also necessary to cut away a small portion of the cast aluminum housing shelf to prevent contact between the shelf and the load-pan supporting cord. A descriptive photo of this is shown in Fig. A3.2.

A3.3 The apparatus used for calibrating the torsion stiffness tester is as follows:

A3.3.1 *Analytical Balance*, accurate to 0.0001 g.

A3.3.2 *Aluminum Pans*, to hold lead shot.

A3.3.3 *Lead Shots*, to be used as weights (approximately 3.20 mm in diameter).

A3.4 The calibration procedure is as follows:

A3.4.1 Position the aluminum pans in place of the weight hangers and place a known load (including pan weight) on the left load pan (calibration load W_c).

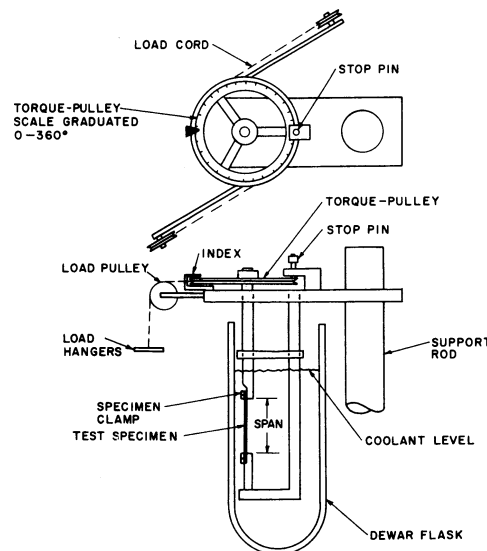

FIG. A3.1 Torsion Tester

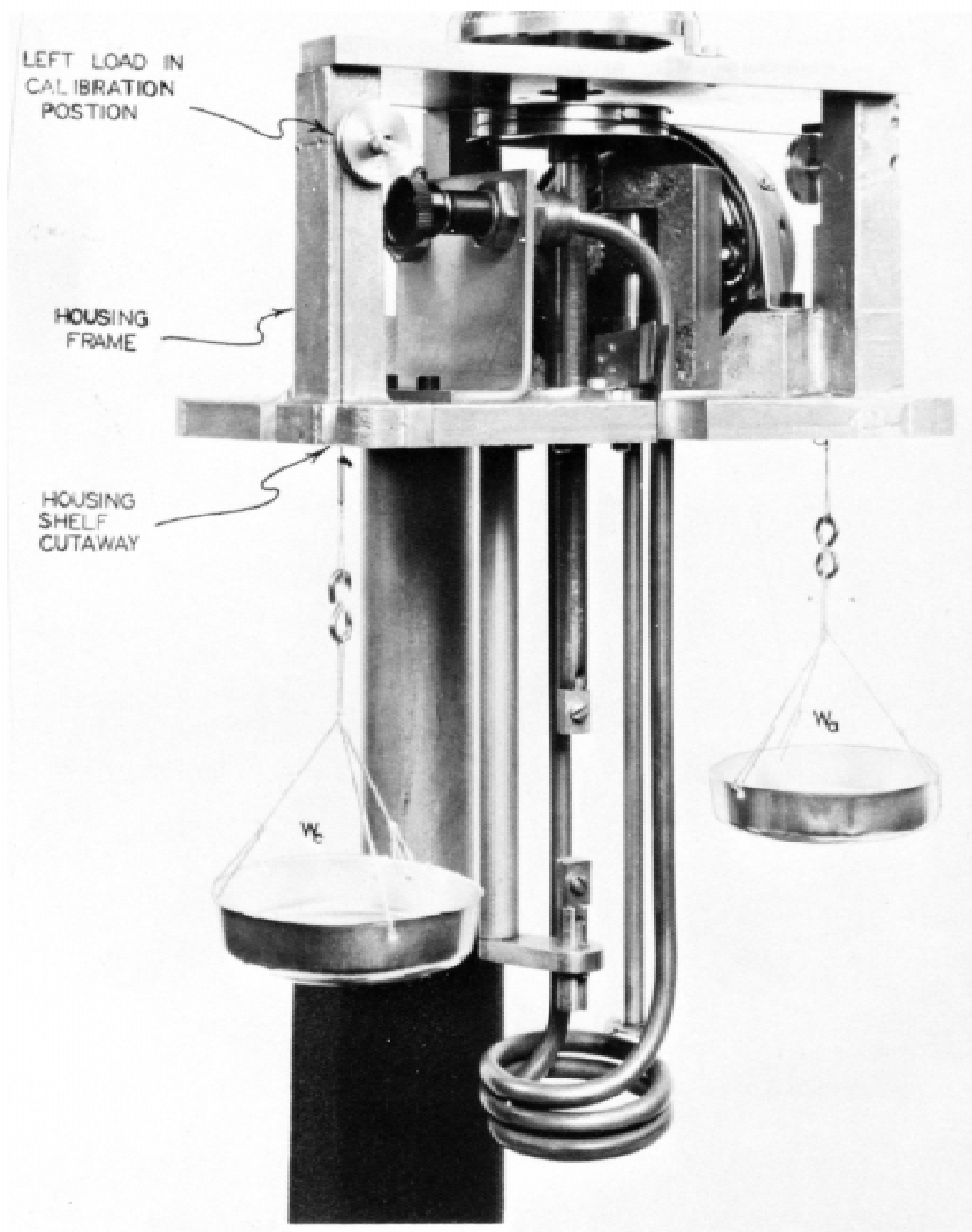

FIG. A3.2 New Calibration Setup for Tinius Olsen Torsion Stiffness Tester

A3.4.2 Turn the stirrer motor on and add sufficient weight to the right pan (applied load W_a) to cause a very slow descent.

A3.4.3 Record both weight loads (including pan weight).

A3.4.4 Repeat steps A3.4.1-A3.4.3 several times using different calibration loads to cover the weight range frequently used.

A3.5 Calculate the output torque for each of the applied loads using the following formula:

$$T_{w_a} = W_c r \quad (A3.1)$$

where:

T_{w_a} = output torque, Newton-metres, for a given applied load (W_a), kg,

W_c = calibration load, kg, and

r = radius of main torque pulley, mm (28.575 mm).

A3.6 Table A3.1 shows calibration data for a modified stiffness tester along with theoretical output values for the applied loads used, assuming no energy losses incurred through friction or other means.

TABLE A3.1 Calibration Data for a Modified Stiffness Tester

Method	Applied Load, W_a (kg)	Calibration Load, W_c (kg)	Radius of Main Torque Pulley (mm)	Output Torque (N-m)
Calibration	0.02927	0.02681	28.575	0.0075
	0.14653	0.14130	28.575	0.040
	0.37117	0.36409	28.575	0.1021
Theoretical ^A	0.02927	0.02927	28.575	0.0082
	0.14653	0.14653	28.575	0.0411
	0.37117	0.37117	28.575	0.1040

^AAssuming no energy losses incurred through friction or other means.

A3.7 Fig. A3.3 shows a slope plot of the theoretical values and that of the alternate calibration method which are very similar. This indicates high instrument efficiency with minimal energy losses.

A4. MODIFICATIONS OF EQUIPMENT OF TORSIONAL STIFFNESS APPARATUS TO EASE THE OPERATION AND INCREASE THE OPERATION AND INCREASE THE ACCURACY AND SENSITIVITY OF THE ACCURACY AND SENSITIVITY OF THE APPARATUS

A4.1 Bearings on Load Pulleys:

A4.1.1 The load pulleys originally supplied with some of the Clash-Berg Torsion-Stiffness Testers were made of brass and mounted on a steel shaft as shown in Fig. A4.1, and when a free spin was imparted to the pulley manually, binding and friction were evident.

A4.1.2 To overcome binding and friction as mentioned above, modify the load pulleys and shaft to accept a press-fit, dust-free, miniature precision ball-bearing as shown in Fig. A4.2. These modifications will eliminate the binding and provide a free-spinning pulley system.

NOTE A4.1—On some of the early models of Clash-Berg type equipment, the weights themselves have been compensated to correct for friction loss. It is suggested that the original weights supplied with the equipment be weighed for accuracy if miniature precision ball bearings, as shown in Fig. A4.2, have been added to the equipment.

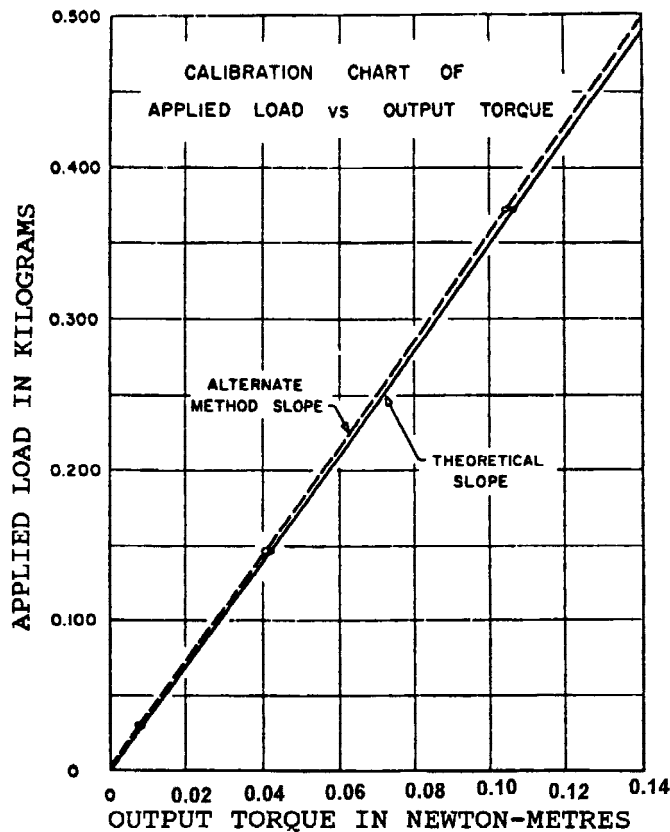

FIG. A3.3 Calibration Chart of Applied Load Versus Output Torque

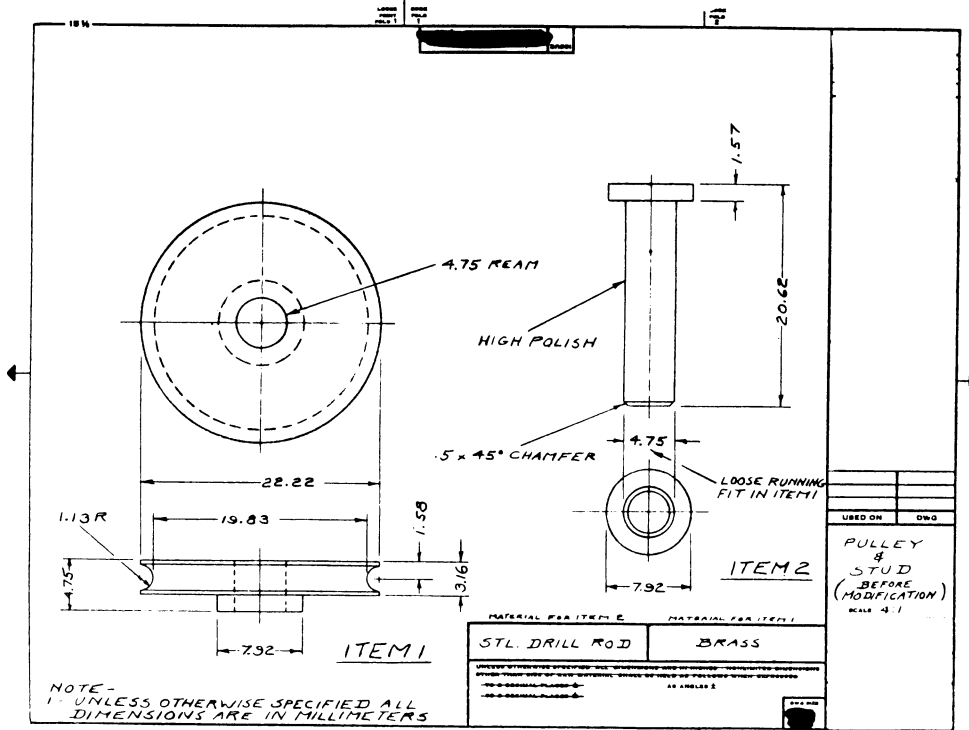

FIG. A4.1 Pulley and Stud (Before Modification)

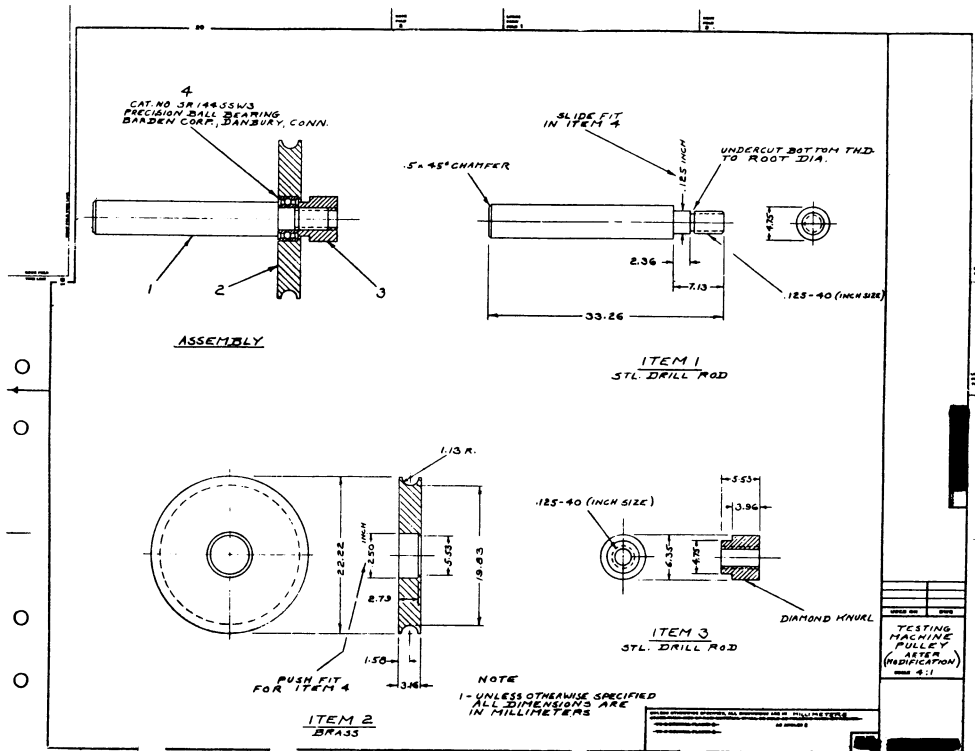

FIG. A4.2 Testing Machine Pulley (After Modification)

A4.2 Modified Lower Clamp:

A4.2.1 When heated over a wide temperature range, plastic specimens will expand and buckle, and when the torque is applied, erroneous readings are obtained.

A4.2.2 To overcome the buckling, modification of the torsional-stiffness apparatus as shown in Fig. A4.3 is necessary. This is done by making a keyway in the lower clamp to allow free vertical movement of the clamp.

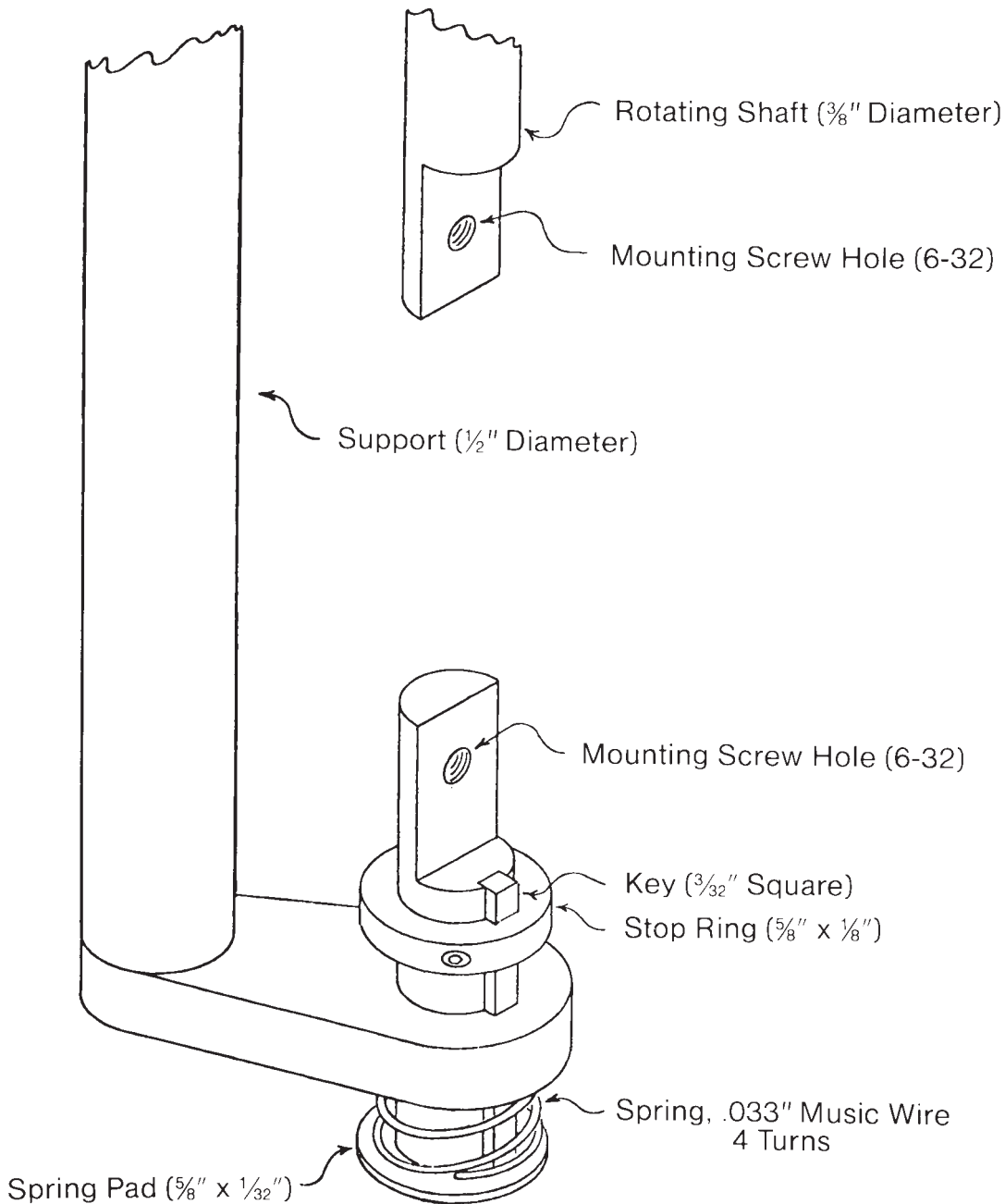

FIG. A4.3 Modification of Clash-Berg Torsional Tester

A4.2.3 Optionally, a light weight compression spring may be used to take up the slack in the specimen when heated. If this is done, care must be taken to insure that the tension applied by the spring does not effect the results of the test.

A4.3 Timer and Stop Mechanisms for Torque Pulley:

A4.3.1 This modification to torsional-stiffness equipment is desirable but not necessary for obtaining meaningful data and can be done by a commercially available timer and electrically-operated brake on the dial. An example of one such device is shown in Fig. A4.4. When modified, the equipment automatically releases the pulley after the 3-min temperature period and then applies a brake after the 5-s loading time.

A4.3.2 Another stop mechanism can be easily designed for the torque pulley to prevent giving the specimen a reverse twist when returning to steady-state position during a series of tests. Again, this is desirable, but not a necessity, for obtaining meaningful data.

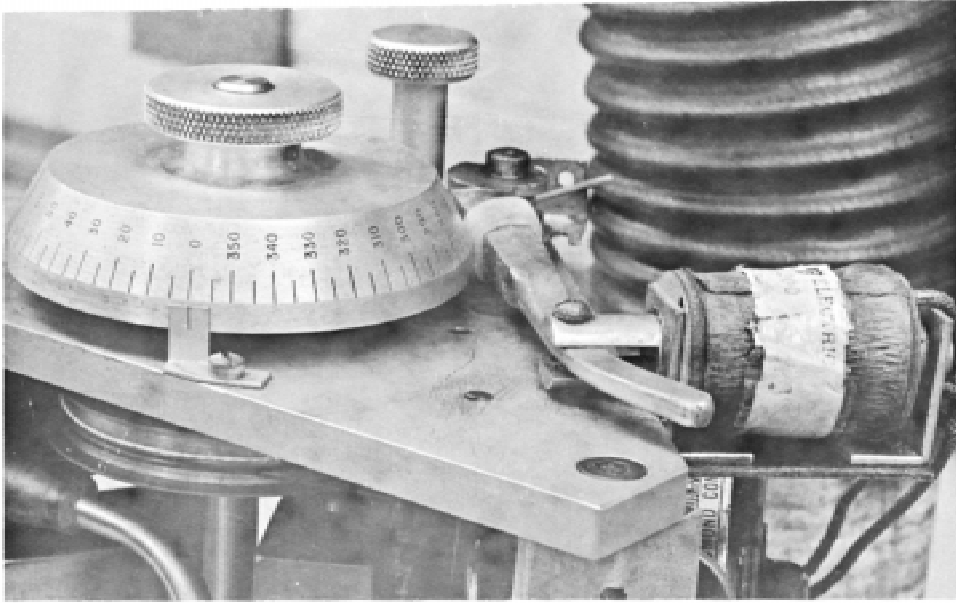

FIG. A4.4 Timer and Solenoid-Operated Brake on Torque Pulley

SUMMARY OF CHANGES

This section identifies the location of selected changes to this test method. For the convenience of the user, Committee D-20 has highlighted those changes that may impact the use of this test method. This section may also include descriptions of the changes or reasons for the changes, or both.

D 1043 – 99 02:

(1) Revised 7.1 and 7.2.

D 1043 – 99:

(1) Several instances of conversion errors were found and corrected, in the method and annex. These errors in conversion from the historical U.S. Customary units of in.·lbf to SI units of N·m were corrected using the conversion factor of 0.11298848 from publication IEEE/ASTM SI 10-1997. This also necessitated some changes in designations in Annex A2.

(2) The requirement to run the test at standard laboratory conditions of $23 \pm 2^\circ\text{C}$ ($73.4 \pm 3.6^\circ\text{F}$) and $50 \pm 5\%$ relative humidity was removed, because the test specimen is held in a sub-ambient temperature test chamber during the test.

(3) Changes were made in the Apparatus and Procedure sections to allow for the use of modernized test equipment, including digital-readout RTD thermometers and automatically controlled refrigeration/heating systems for controlling the temperature of the heat transfer liquid in the Dewar flask.

(4) Section 6.1 was changed to allow other types of specimens to be used, in addition to those cut from compression-molded sheet.

(5) Section 6.3 was changed to suggest when an additional test specimen should be tested.

(6) Section 8.7 was changed to specify a minimum of 3 minutes of conditioning time at the test temperature rather than the much more restrictive limits of 3 min +15 s, -0 s. This change was made because there was no data to show that longer conditioning times have any adverse effect on the results, and there was some question if a 3-min conditioning time was always adequate to fully condition the specimen to the test temperature.

(7) Section 9.3 was changed to allow determination from the graph of the temperature at which the apparent modulus of rigidity equals other standard values, in addition to at other T_F where the modulus is equal to 310.3 MPa (45 000 psi).

(8) Precision data was added to the Precision and Bias section, based on limited testing in one laboratory of one flexible vinyl (plasticized PVC) material.

ASTM International takes no position respecting the validity of any patent rights asserted in connection with any item mentioned in this standard. Users of this standard are expressly advised that determination of the validity of any such patent rights, and the risk of infringement of such rights, are entirely their own responsibility.

This standard is subject to revision at any time by the responsible technical committee and must be reviewed every five years and if not revised, either reapproved or withdrawn. Your comments are invited either for revision of this standard or for additional standards and should be addressed to ASTM International Headquarters. Your comments will receive careful consideration at a meeting of the responsible technical committee, which you may attend. If you feel that your comments have not received a fair hearing you should make your views known to the ASTM Committee on Standards, at the address shown below.

This standard is copyrighted by ASTM International, 100 Barr Harbor Drive, PO Box C700, West Conshohocken, PA 19428-2959, United States. Individual reprints (single or multiple copies) of this standard may be obtained by contacting ASTM at the above address or at 610-832-9585 (phone), 610-832-9555 (fax), or service@astm.org (e-mail); or through the ASTM website (www.astm.org).