



Designation: **D 3275 – 9700**

An American National Standard

Standard Specification Classification for E-CTFE-Fluoroplastic Molding, Extrusion, and Coating Materials¹

This standard is issued under the fixed designation D 3275; the number immediately following the designation indicates the year of original adoption or, in the case of revision, the year of last revision. A number in parentheses indicates the year of last reapproval. A superscript epsilon (ϵ) indicates an editorial change since the last revision or reapproval.

This standard has been approved for use by agencies of the Department of Defense.

1. Scope*

1.1 This ~~spec~~ classification covers melt processible molding, extrusion, and coating materials of ethylene-chlorotrifluoroethylene (E-CTFE) fluoroplastics. The resin is a copolymer of ethylene and chlorotrifluoroethylene containing approximately 80 weight % of chlorotrifluoroethylene.

1.2 The values stated in SI units, as detailed in ~~Practice E 380~~, IEEE/ASTM SI 10, are to be regarded as the standard.

1.3 The following precautionary statement pertains only to the test methods portion, Section 11 of this specification. *This standard does not purport to address all of the safety concerns, if any, associated with its use. It is the responsibility of the user of this standard to establish appropriate safety and health practices and determine the applicability of regulatory limitations prior to use.*

NOTE 1—Although this specification and ISO 12086-1 (1994⁵) and ISO 12086-2 (1994⁵) differ in approach or detail, data obtained using either are technically equivalent.

2. Referenced Documents

2.1 ASTM Standards:

D 150 Test Methods for A-C Loss Characteristics and Permittivity (Dielectric Constant) of Solid Electrical Insulating Materials²

¹ This specification is under the jurisdiction of ASTM Committee D-20 on Plastics and is the direct responsibility of Subcommittee D20.15 on Thermoplastic Materials (Section 20.15.12).

Current edition approved ~~April Dec. 10, 1997~~, 2000. Published ~~April 1998~~, March 2001. Originally published as D 3275 – 73. Last previous edition D 3275 – 94~~a~~7.

***A Summary of Changes section appears at the end of this standard.**

			Specification
01	1	Low melt flow rate	1
	2	Medium melt flow rate	1
	3	High melt flow rate	1
	0	Other	0
02	1	Low melt flow rate	1
	2	Medium melt flow rate	1
	3	High melt flow rate	1
	0	Other	0
Example:		Other	1
Specification			
		D 3275-97,	
00	0	Other	0

For this example, the line callout would be Specification D 3275 and would specify a low melt flow rate extrusion and molding grade

^A See 11.2 for test method for above parameters.

^B See 11.4 for test method for above parameters.

^C See 11.5 for test method for above parameters.

^D At 23 ± 2°C (73.4 ± 3.6°F).

^E See 11.5 for test method for above parameters.

^F See 11.3 for test method for above parameters.

^G See 11.7 for test method for above parameters.

^H See 11.6 for test method for above parameters.

^I See 11.6 for test method for above parameters.

4.1.1 To facilitate incorporation of E-CTFE that has all of future material, the properties listed other category for that Type in the appropriate tables, or both, in the specification identified. A comma is used as the separator between the Standard Number Group (00), Class (0) and the Type-Grade (0) are shown in Table E-CTFE.

5. Ordering Information

5.1 The purchase order or inquiry for these materials shall state the specification number and type classification callout. For example, ~~D 3275 Type I~~, D 3275 ECTFE 01 1 2.

5.2 Further definition, as may be required for the following, shall be on the basis of agreement between the seller and the purchaser:

5.2.1 Nominal Melt-Flow Rate.

6. General Requirements

6.1 The material covered by this specification shall conform to the requirements prescribed in Table 1 and Table 2 E-CTFE when tested by the procedures specified ~~herein~~. Table 2 lists those tests requiring a specimen molded as described in 10.1.1. herein.

7. Detail Requirements

7.1 Test specimens prepared in accordance with Section 10 shall conform to the requirements prescribed for the particular ~~type and grade in Table 1 and Table 2~~, class.

8. Sampling

~~8.1 Unless otherwise agreed upon between the purchaser and the seller, the materials shall~~

8.1 Sampling must be sampled in accordance with statistically adequate to satisfy the procedure described in Sections 1 and 12, as applicable, in Practice D 1898. Adequate statistical sampling shall be considered an acceptable alternative requirements of 12.4.

9. Number of Tests

9.1 One set of test specimens as prescribed in Section 11 shall be considered sufficient for testing each sample. The average

result of the specimens tested shall conform to the requirements of this specification.

10. Specimen Preparation

10.1 Test Specimens:

10.1.1 Prepare test moldings 3.18 ± 0.3 mm (0.125 ± 0.012 in.) thick between two 0.38 to 0.51 mm (0.015 to 0.020 in.) thick chromium-plated ferrotype plates. Use a “picture frame” type compression molding chase with inner dimensions of 178 by 178 mm (7 by 7 in.) and having a thickness suitable to produce the required molded sheet. Use a charge of resin sufficient to provide the thickness sheet specified.

10.1.2 Place the mold chase on top of a chromium-plated ferrotype plate. Charge a quantity of resin sufficient to produce a 3.18 ± 0.30 -mm (0.125 ± 0.012 -in.) sheet in a diagonal pattern from corner to corner forming an “x” “X” pattern. Place the other chromium-plated ferrotype plate on top of the resin charge and place the assembly in a compression molding press which has been heated to $264 \pm 3^\circ\text{C}$ ($507 \pm 5.4^\circ\text{F}$). Apply a pressure of 0.34 MPa (50 psi) and hold for 4 min. Increase pressure to 1.72 MPa (250 psi) and hold for 1 min followed by increasing the pressure to not less than 2.24 MPa (325 psi) and holding for 5 min. Remove the chase assembly from the press and immediately quench it in an ice-water bath, vigorously agitating the chase. Remove the ferrotype plates, keeping the chase and molded sheet in the ice water bath until quenching is complete.

11. Test Methods

11.1 Conditioning:

11.1.1 For tests of specific gravity, tensile properties, oxygen index, and electrical properties, condition the molded test specimens in accordance with Procedure A of Practice D 618, with the exception that only 4-h conditioning is required.

11.1.2 Conduct tests at the standard laboratory temperatures of $23 \pm 2^\circ\text{C}$ ($73.4 \pm 3.6^\circ\text{F}$) for determination of specific gravity, tensile properties, and electrical properties. Since the resin does not absorb water, the maintenance of constant humidity during testing is not necessary. Conduct tests for melt flow rate, oxygen index, and melting endotherm under ordinary laboratory conditions.

11.2 *Melt Flow Rate*—Determine the melt flow rate in accordance with Test Method D 1238 modified by use of corrosion-resistant alloy for the barrel lining, orifice, and piston tip.

11.3 *Melting Endotherm Peak*—Determine the melting endotherm peak in accordance with Test Method D 4591. For instruments capable of digital data processing of the melting endotherm curve, the peak maximum, as determined by the point on the curve for which the tangent has zero slope, may be reported as the melting point. Additionally, the heat of fusion and recrystallization may be reported directly from the display of the data processing equipment provided that the instrument has been calibrated with a standard material as defined in Test Method D 4591.

11.3.1 Other thermal techniques, such as differential thermal analysis; (DTA), capable of measuring the melting endotherm peak and giving equivalent results, may be ~~used~~ used.

11.4 *Specific Gravity*—Cut two specimens from the compression molded sheet and test in accordance with Test Methods ~~D 792~~ or D 1505. If the latter is used, the tube shall have a linear gradient over the specific gravity range of approximately 1.63 to 1.73. ~~D 792.~~

11.5 *Tensile Properties*—Determine the tensile properties in accordance with Test Method D 638 and test specimen of Fig. 1 in this specification, except that the initial jaw separation shall be 22.2 ± 0.13 mm (0.875 ± 0.005 in.), and the speed of testing shall be 51 mm/min (2 in./min). Clamp the specimens with essentially equal lengths in each jaw. Determine the elongation from the chart, expressing it as a percentage of the initial jaw separation. The test specimen and die identified in Test Method D 1708 may also be used.

~~11.5.1 Precision and Bias—The precision and bias of this test method are to be determined.~~

11.6 *Dielectric Constant and Dissipation Factor*—Determine the dielectric constant and dissipation factor on three specimens, each 50.8 mm (2 in.) in diameter in accordance with Test Methods D 150. Testing shall be at 60 Hz and 10^6 Hz.

11.7 *Oxygen Index*—Determine the oxygen index in accordance with Test Method D 2863.

12. Inspection and Certification

12.1 Inspection and certification of the material supplied with reference to a specification based on this classification system shall be for conformance to the requirements specified herein.

12.2 Lot-acceptance shall be the basis on which acceptance or rejection of the lot is made. The lot-acceptance inspection shall consist of melt flow rate determination.

12.3 Periodic check inspection with reference to a specification based on this classification system shall consist of the tests for all requirements of the material under the specification. Inspection frequency shall be adequate to insure the material is certifiable in accordance with 12.4.

12.4 Certification shall be that the material was manufactured by a process in statistical control, sampled, tested, and inspected in accordance with this classification system, and that the average values for the lot meet the requirements of the specification (line callout).

12.5 A report of test results shall be furnished when requested. The report shall consist of results of the lot-acceptance inspection for the shipment and the results of the most recent periodic-check inspection.

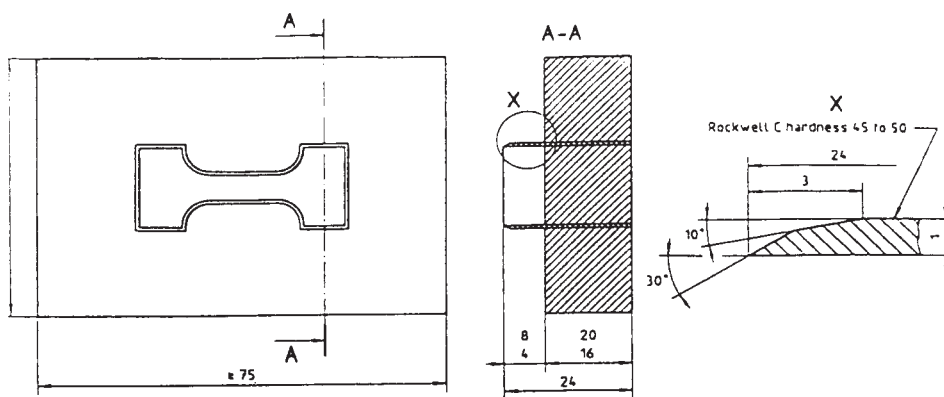

Steel-rule die
(inside dimensions for die are the same as test specimen)
Die to be sharpened on outside edge only (as shown in A-A)

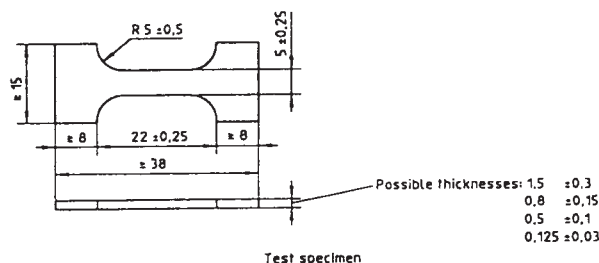

Test specimen

FIG. 1 Test Specimen and Die

13. Packaging and Package Marking

123.1 *Packaging*—The material shall be packaged in standard commercial containers so constructed as to ensure acceptance by common or other carriers for safe transportation to the point of delivery unless otherwise specified in the contract or order.

123.2 *Marking*—Shipping containers shall be marked with the name of the material, type, or melt index, and quantity therein.

123.3 All packing, packaging, and marking provisions of Practice D 3892 shall apply to this specification.

134. Keywords

134.1 chlorotrifluoroethylene copolymers; chlorotrifluoro- ethylene-ethylene copolymers; E-CTFE; extrusion material; fluoropolymer; fluoropolymers; melt flow; melt-processible fluoropolymer; molding material; powder coating; roto-molding; roto-molding

APPENDIX

(Nonmandatory Information)

X1. CLASSIFICATION

INTRODUCTION

This information is included to enable an easy comparison of the previous classification system (D 3275–97) and the current Classification D 4000 format system. This appendix will be deleted as part of the next revision.

X1.1 This specification covers three types of E-CTFE-fluoroplastic supplied in pellet or powder forms for molding, extrusion, and coatings:

X1.1.1 *Type I*—Low melt flow rate.

X1.1.2 *Type II*—Medium melt flow rate.

X1.1.3 *Type III*—High melt flow rate.

X1.2 A one-line system may be used to specify materials covered by this specification. The system uses predefined cells to refer to specific aspects of this specification, as illustrated below.

Standard Number	Specification	Type
Block	:	:
:	:	:
:	:	:
Example: Specification D 3275 – 97,	:	I

For this example, the line callout would be Specification D 3275 and would specify a low melt flow rate extrusion and molding grade of E-CTFE that has all of the properties listed for that Type in the appropriate tables, or both, in the specification identified. A comma is used as the separator between the Standard Number and the Type.

TABLE X1.2 Detail Requirements for Molded Test Specimens of Types I, II, and III Resins

Specific gravity, 23/23°C (73.4/73.4°F):	
min	1.65
max	1.71
Ultimate Tensile strength, 23°C (73.4°F), min:	
MPa	41.4
psi	6000
Ultimate Elongation, 23°C (73.4°F), min, %:	200
Oxygen index, min, %:	52
Dielectric constant, max:	
106 Hz	2.6
Dissipation factor, max:	
10 ⁶ Hz	0.015

SUMMARY OF CHANGES

Committee D-20 has identified

This section identifies the location of selected changes to this specification since classification. For the last issue convenience of the user, Committee D20 has highlighted those changes that may impact the use of this specification. This section may also include descriptions of the changes or reasons for the changes, or both.

D 3275 – 9700:

- (1) Wording is added in Section 1 Changed title from “Standard Specification” to state equivalency of this specification with ISO 12086: “Standard Classification.”
- (2) The callout example has been changed in Deleted Practice D 1898 from Section 4. An example based on this specification is used for better clarification. 2.
- (3) A maximum value for melt flow index for Type III Material is added to Table 1. In the previous edition the maximum melt flow index for Type III was open ended. Replaced Practice E 380 with IEEE/ASTM SI 10 in 1.2 and Section 2.
- (4) A footnote is added to Table 1 to the minimum melting point specification. The footnote provides an alternative minimum melting point of 239°C when DSC digital software is used to identify melting endotherm peaks. Software that identifies the peak as the point on the curve where the tangent has zero slope may give results 1°C lower than the method described in Deleted Test Method D 4591. D 1505 from Section 2 due to cancer causing nature of solvents employed.

TABLE X1.1 Detail Requirements for Test on Molding Materials

	Type I	Type II	Type III
Melt flow rate, g/10 min:			
min	0.05	0.85	4.1
max	0.84	4.0	25
Melting endotherm peak, min, °C	240 ^A	240 ^A	240 ^A

^A If the melting peak endotherm is determined by a digital method that calculates the peak by determining when the tangent has zero slope, as described in 11.3, the result can be lower than when the method defined in Test Method D 4591 is used. For this reason, the minimum melting point specification must be reduced to 239°C when the former approach is used.

- (5) ~~Eliminated wording in Section 11 that further defined the use of Test Method D 1238~~ Added new definition for use with E-CTFE. Melt flow rate for E-CTFE is fully defined by Test Method D 1238 in this specification. *lot* (3.1.1).
- (6) ~~Eliminated 11.3.1 through 11.3.3 that defined the method for determining melting endotherm peak. This specification now references Test Method D 4591 to define the procedure to measure melting endotherm peak. Wording is added in 11.3 to give an alternate method of determining transition temperatures as defined in Test Method D 4591. the alternate method takes into account the more common peak determination method used in most computer based differential scanning calorimeter (DSC) software programs. Added abbreviations section (3.2).~~
- (7) ~~Deleted all references to Table 2 from document.~~
- (8) ~~In Section 4, classification system changed to D 4000 format and test specimen defined old system put in Test Method D 1708 is included in 11.5 Appendix X1 for use reference for less than or equal to determine tensile properties. This is added because E-CTFE plaques can be difficult five years.~~
- (9) ~~Changed melt flow rates from 0.05–0.84, 0.85–4.0, and 4.1–25 to cut 0.05–1.5, 1.51–6.0, and the die specified in Test Method D 1708 is sturdier. 6.1–25 for low, medium, and high melt flow materials.~~
- (10) ~~Changed oxygen index from 52 min to 60 min.~~
- (11) ~~Added new Section 12, Inspection and Certification.~~

ASTM International takes no position respecting the validity of any patent rights asserted in connection with any item mentioned in this standard. Users of this standard are expressly advised that determination of the validity of any such patent rights, and the risk of infringement of such rights, are entirely their own responsibility.

This standard is subject to revision at any time by the responsible technical committee and must be reviewed every five years and if not revised, either reapproved or withdrawn. Your comments are invited either for revision of this standard or for additional standards and should be addressed to ASTM International Headquarters. Your comments will receive careful consideration at a meeting of the responsible technical committee, which you may attend. If you feel that your comments have not received a fair hearing you should make your views known to the ASTM Committee on Standards, at the address shown below.

This standard is copyrighted by ASTM International, 100 Barr Harbor Drive, PO Box C700, West Conshohocken, PA 19428-2959, United States. Individual reprints (single or multiple copies) of this standard may be obtained by contacting ASTM at the above address or at 610-832-9585 (phone), 610-832-9555 (fax), or service@astm.org (e-mail); or through the ASTM website (www.astm.org).