



# Standard Test Methods for Solid Filling and Treating Compounds Used for Electrical Insulation<sup>1</sup>

This standard is issued under the fixed designation D 176; the number immediately following the designation indicates the year of original adoption or, in the case of revision, the year of last revision. A number in parentheses indicates the year of last reapproval. A superscript epsilon ( $\epsilon$ ) indicates an editorial change since the last revision or reapproval.

## 1. Scope

1.1 These test methods cover physical and electrical tests for solid filling and treating compounds used for electrical insulation which are fusible to a liquid without significant chemical reaction. Compounds that are converted to the solid state by polymerization, condensation, or other chemical reaction are not included in these test methods.

1.2 These test methods are designed primarily for asphaltic or bituminous compounds, waxes, and fusible resins, or mixtures thereof, although some of these methods are applicable to semisolid types such as petrolatums. Special methods more suitable for hydrocarbon waxes are contained in Test Methods D 1168.

1.3 Adequate ventilation must be provided when these tests involve heating.

1.4 The test methods appear in the following sections:

Test Method	Sections
<i>Electrical Tests:</i>	42-54
A-C Loss Characteristics and Permittivity (Dielectric Constant)	51-54
Dielectric Strength	42-45
Volume Resistivity-Temperature Characteristics	46-49
<i>Physical Tests:</i>	5-41
Coefficient of Expansion or Contraction	22-41
Flash and Fire Points	9 and 10
Loss on Heating	11 and 12
Melting Point	5 and 6
Penetration	15 and 16
Softening Point	7 and 8
Specific Gravity	17-21
Viscosity	13 and 14

1.5 The values stated in SI units are to be regarded as the standard. The values given in parentheses are for information only.

1.6 *This standard does not purport to address all of the safety concerns, if any, associated with its use. It is the responsibility of the user of this standard to establish appropriate safety and health practices and determine the applicability of regulatory limitations prior to use.* For specific hazard statements, see Note 3 and Note 6.

## 2. Referenced Documents

### 2.1 ASTM Standards:

- D 5 Test Method for Penetration of Bituminous Materials<sup>2</sup>
- D 6 Test Method for Loss on Heating of Oil and Asphaltic Compounds<sup>3</sup>
- D 70 Test Method for Specific Gravity of Semi-Solid Bituminous Materials<sup>2</sup>
- D 71 Test Method for Relative Density of Solid Pitch and Asphalt (Displacement Method)<sup>4</sup>
- D 88 Test Method for Saybolt Viscosity<sup>3</sup>
- D 92 Test Method for Flash and Fire Points by Cleveland Open Cup<sup>4</sup>
- D 127 Test Method for Drop Melting Point of Petroleum Wax, Including Petrolatum<sup>4</sup>
- D 149 Test Method for Dielectric Breakdown Voltage and Dielectric Strength of Solid Electrical Insulating Materials at Commercial Power Frequencies<sup>5</sup>
- D 150 Test Methods for AC Loss Characteristics and Permittivity (Dielectric Constant) of Solid Electrical Insulating Materials<sup>5</sup>
- D 257 Test Methods for D-C Resistance or Conductance of Insulating Materials<sup>5</sup>
- D 937 Test Method for Cone Penetration of Petrolatum<sup>4</sup>
- D 1168 Test Methods for Hydrocarbon Waxes Used for Electrical Insulation<sup>5</sup>
- E 28 Test Method for Softening Point by Ring-and-Ball Apparatus<sup>6</sup>
- E 102 Test Method for Saybolt Furol Viscosity of Bituminous Materials at High Temperatures<sup>3</sup>

## 3. Terminology

### 3.1 Definitions:

3.1.1 *dielectric strength, n*—the voltage gradient at which dielectric failure of the insulating material occurs under specific conditions of test.

### 3.2 Definitions of Terms Specific to This Standard:

3.2.1 *loss on heating, n*— of filling or treating compound, the change in weight of a compound when heated under

<sup>1</sup> These methods of testing are under the jurisdiction of ASTM Committee D-9 on Electrical and Electronic Insulating Materials and are the direct responsibility of Subcommittee D09.01 on Electrical Insulating Varnishes, Powders, and Encapsulating Compounds.

Current edition approved March 10, 1996. Published May 1996. Originally published as D 176 – 23 T. Last previous edition D 176 – 91.

<sup>2</sup> Annual Book of ASTM Standards, Vol 04.03.

<sup>3</sup> Annual Book of ASTM Standards, Vol 04.04.

<sup>4</sup> Annual Book of ASTM Standards, Vol 05.01.

<sup>5</sup> Annual Book of ASTM Standards, Vol 10.01.

<sup>6</sup> Annual Book of ASTM Standards, Vol 06.03.

prescribed conditions at a standard temperature for a specified time.

3.2.2 *melting point, n— of filling or treating compound*, the temperature at which the compound becomes sufficiently fluid to drop from the thermometer used in making the determination under prescribed conditions.

3.2.3 *penetration, n— of filling or treating compound*, the distance traveled by a standard needle (or cone) as it pierces a specimen under specified conditions of load, time and temperature.

3.2.4 *softening point, n— of filling or treating compound*, the temperature at which the central portion of a disk of the compound held within a horizontal ring of specified dimensions has sagged or flowed downward a distance of 25.4 mm (1 in.) under the weight of a 9.5-mm ( $\frac{3}{8}$ -in.) diameter steel ball as the sample is heated at a prescribed rate in a water or glycerin bath.

#### 4. Sampling and Conditioning

4.1 Due to the diverse nature of the compounds and the various forms and packages commercially available, no standard methods of sampling have been established. When the sample is in the form of cakes or ingots, a representative sample may usually be secured by breaking or cutting a transverse section from the middle of the cake or ingot. When

the material is shipped in pails or drums, a sample may be removed with a clean knife, hatchet, auger or other cutting tool, discarding the top 50 or 75 mm (2 or 3 in.) of the compound. Melting of the compound should be avoided unless it can be poured directly into the testing container. A melting and pouring temperature of 50°C (90°F) above the softening point is recommended for filling testing containers with asphaltic compounds. Take care not to overheat the compound nor to entrap air.

4.2 With certain materials that tend to entrap gasses due to high viscosity at pouring temperatures, or to froth on heating, it may be necessary to degas the material prior to testing in order that consistent results may be secured (unless the particular test includes such procedure). If degassing is required, it shall be performed by heating the material in a vacuum oven. The temperature and vacuum shall be high enough, and the time long enough to ensure driving off the mechanically entrapped gasses, but should tend to decompose as little as possible. A temperature 50°C (90°F) higher than the softening point of the compound, an absolute pressure of 6.9 to 20.7 kPa (1 to 3 psi), and a time of 30 to 45 min are recommended for asphaltic compounds. The sample shall then be poured into the testing container.

### PHYSICAL TESTS

#### MELTING POINT

##### 5. Significance and Use

5.1 The melting point is useful in selecting a filling or treating compound that will not flow at the operating temperature of the device in which it will be used. It is also essential that it shall not be so high as to injure the insulation at the time of pouring. This test method may be used for specification, classification, and for control of product uniformity.

##### 6. Procedure

6.1 Determine the melting point of petrolatums, waxes, and similar compounds of a relatively sharp melting point by Test Method D 127.

NOTE 1—This method should not be used for asphalts and other types with a prolonged melting range.

#### SOFTENING POINT

##### 7. Significance and Use

7.1 The softening point is useful in selecting a filling or treating compound that will not flow at the operating temperature of the device in which it is used. It is also an indication of the pouring temperature, which should not be so high as to injure the insulation of a device. This test method is used, when the compound has no definite melting point, for purposes of specification, classification, and control of product uniformity.

##### 8. Procedure

8.1 Determine the softening point in accordance with Test Method E 28.

#### FLASH AND FIRE POINTS

##### 9. Significance and Use

9.1 The flash and fire points must be high enough so that the possibility of an explosion or fire is at a minimum when the compounds are being heated and poured. A flash point at least 35°C (63°F) above the pouring temperature is usually considered necessary for safe operations. An unusually low flash point for a given compound indicates a mixture or contamination with a volatile material. This test method is useful for purposes of specification, classification, and control of product uniformity.

##### 10. Procedure

10.1 Determine the flash and fire points of all compounds in accordance with Test Method D 92.

10.2 In the case of certain compounds containing chlorine, the flash may be indefinite and no fire point may exist. Report this fact.

#### LOSS ON HEATING

##### 11. Significance and Use

11.1 Loss on heating includes loss of moisture and volatile constituents less any weight gain due to oxidization. It is useful for control of product uniformity and as an indication of pot or tank life if the test is performed at the appropriate temperature. This test method shall not be used to compare compounds of different basic chemical compositions.

## 12. Procedure

12.1 Determine the loss on heating of asphaltic and certain other types of compounds by Test Method D 6.

NOTE 2—The reproducibility of this test method may be poor due to insufficient control of the air circulation over the specimens and to weight gain from oxidation of some compounds. With certain compounds it may be desirable to conduct the test at a lower temperature than the specified temperature of 163°C (325.4°F).

NOTE 3—**Caution:** When compounds of low flash point and high volatility are tested, the oven shall have low-temperature heating elements and a safety door latch to relieve pressure in case of an explosion.

## VISCOSITY

### 13. Significance and Use

13.1 The Saybolt viscosity is nearly proportional to the kinematic viscosity of filling and treating compounds and hence, it is an indication of whether or not the material will flow readily under its own weight at a prescribed temperature. It is also satisfactory for control of product uniformity and for specification purposes.

### 14. Procedure

14.1 For waxes, petrolatums, and other low-viscosity-type compounds determine the viscosity as Saybolt Universal viscosity by Test Method D 88. The standard temperatures for testing are: 21, 38, 54, or 99°C (70, 100, 130, or 210°F).

14.2 For asphaltic and other high-viscosity compounds, determine the Saybolt Furol viscosity. The standard temperatures for testing Furol viscosity are: 25, 38, 50, 60, 82, and 99°C (77, 100, 122, 140, 180, 210°F).

14.3 For higher temperatures, special techniques and thermometers are required. The standard temperatures are 121, 149, 177, 204, and 232°C (250, 300, 350, 400, 450°F). In these cases determine the viscosity by Test Method E 102.

NOTE 4—For testing waxes and petrolatums, the standard temperature for comparison purposes is 99°C (210°F), and Saybolt Universal viscosity is used. For estimation of the properties of asphaltic and other compounds of high viscosity, it is desirable to measure the viscosity at a number of standard temperatures above the softening point. A curve may be plotted on log-log paper and the temperature at which the Saybolt Furol viscosity is 470 s may be determined. This viscosity corresponds approximately to a kinematic viscosity of 1000 centistokes, and is a viscosity at which the compound may conveniently be poured from the container. With potting compounds, it is also desirable to know the temperature at which the Saybolt Furol viscosity is 100 s, since this viscosity is low enough for production potting operations.

## PENETRATION

### 15. Significance and Use

15.1 Penetration is an indication of the softness or indentability of a compound. Penetration values are used as a basis for classification, specification, and control of product uniformity.

### 16. Procedure

16.1 Determine penetration in accordance with Test Method D 5. This test method is applicable to all compounds except very soft materials and petrolatums. Unless specified otherwise, the standard conditions of test are:

	Weight, g	Time, s
At 25°C (77°F)	100	5

Other standard conditions are:

	Weight, g	Time, s
At 0°C (32°F)	200	60
At 46°C (115°F)	50	5

16.2 For very soft materials, such as petrolatums, use Test Method D 937.

## SPECIFIC GRAVITY

### 17. Significance and Use

17.1 Specific gravity is useful for indicating product uniformity and for calculating the weight of a given volume of material. In some instances it is useful in estimating the amount of mineral fillers in a compound. If specific gravity is known at several temperatures, the coefficient of expansion may be calculated. If the specific gravity of a compound is determined before and after degassing, the volume of entrapped gases may be calculated.

17.2 Displacement tests are used to determine the specific gravity of both untreated and degassed compounds. Conventional methods are used for the solid state, and plummet displacement for the liquid state. The values obtained may then be used to compute the approximate coefficient of cubical expansion by Test Method C (see Sections 34-36).

## WATER DISPLACEMENT METHODS

### 18. Procedure

18.1 Determine the specific gravity by Test Method D 71 or Test Method D 70.

## PLUMMET DISPLACEMENT METHOD

### 19. Scope

19.1 The specific gravity of the material at the desired temperature is calculated from the weight of the compound displaced by a calibrated aluminum plummet.

### 20. Apparatus

20.1 *Balance*—An analytical balance equipped with pan straddle.

20.2 *Plummet*—An aluminum plummet of suitable shape weighing 5 to 10 g.

20.3 *Beaker*—A 400-mL heat-resistant glass beaker wrapped with a suitable thermal insulation.

20.4 *Thermometer*—A thermometer of suitable range.

20.5 *Wire*—Two pieces of fine copper wire.

### 21. Procedure

21.1 *Calibration of Plummet*—Make the following weight determinations of the plummet to the nearest 1 mg as follows:

$$a - b = \text{weight of water displacement in grams at } 25^{\circ}\text{C (77}^{\circ}\text{F)} \quad (1)$$

where:

$a$  = weight in air, g, and

$b$  = weight suspended in water, g, at 25°C (77°F).

21.2 Correct the value of the plummet displacement ( $D_p$ ) in terms of grams of water at 25°C (77°F) to the pouring temperature,  $t_p$ , in degrees Celsius, by means of the following equation

$$D_p = 0.000076(t_p - 25)(a - b) + (a - b) \quad (2)$$

NOTE 5—The factor 0.000076 is the coefficient of cubical expansion per degree Celsius.

21.3 *Testing of the Sample*—Carefully melt the sample in the beaker and raise the temperature to approximately 15°C (27°F) above the desired test temperature. Place the beaker on the straddle and suspend the plummet in the compound by the fine copper wire. (The weight of the wire should be tared.)

21.4 Balance the scales approximately and at the same time stir the sample slowly, using the thermometer as a stirring rod. When the sample has cooled to the desired temperature, rapidly complete the weighing.

21.5 *Calculation of Specific Gravity,  $t_p/25$  C*—Calculate the specific gravity as follows:

$$\text{Sp gr, } t_p/25 \text{ C} = (W_a - W_c)/D_p \quad (3)$$

where:

$W_a$  = weight of plummet in air, g, and

$W_c$  = weight of plummet in compound, g.

## COEFFICIENT OF EXPANSION OR CONTRACTION

### 22. Scope

22.1 The following four test methods are included:

22.1.1 *Test Methods A and B*—Methods A and B for true coefficient of expansion are intended for use only where the uniformity of the material under test justifies a high degree of precision. Test Method A is suitable for testing low-viscosity types such as waxes and petrolatums. Test Method B is suitable for testing asphalts and high-viscosity materials, also for opaque materials that may give difficulty in reading the glass scale of Test Method A.

22.1.2 *Test Methods C and E*—Test Methods C and E are intended for faster testing where high precision may not be justified. These test methods may be used for determining either true or effective coefficient of expansion but are not used as referee test methods.

### 23. Significance and Use

23.1 Coefficient of expansion is useful in computing the amount of void space that will remain in a device filled with compound after the compound has cooled to the ambient temperature. It also is one indication of the thermal shock resistance of a compound.

23.2 The effective coefficient of expansion is determined on materials that have not been degassed just prior to test. It is important for many purposes to know the effective coefficient of the material as received or after heating to the maximum temperature of application. Consistent results, however, may only be obtained with gas-free compounds.

## TEST METHOD A—USING GLASS FLASK

### 24. Apparatus

24.1 *Flask*—A glass flask<sup>7</sup> holding approximately 250 mL to the zero mark, and graduated for 25 mL in 0.1-mL divisions, the neck of the flask being 10 mm in internal diameter.

24.2 *Oil Bath*—For heating the sample, a cylindrical oil bath approximately 25.4 cm (10-in.) inside diameter and 50 cm (20 in.) in inside depth with a false bottom 2.5 cm (1 in.) from the bottom and provision for circulating and heating the oil.

24.3 *Metal Collar*—Lead or iron collars for use on the neck of the flask during test to prevent oil currents of the bath from moving the flask.

### 25. Calibration

25.1 The capacity of the flask at the zero point and several points on the scale, shall be determined by filling the flask with distilled water at a known temperature and weighing.

### 26. Procedure

26.1 Maintain the flask under a vacuum of 635 mm (25 in.) Hg at a temperature 50°C (90°F) higher than the softening point (ring and ball method, as determined in accordance with Section 8) while filling, and for approximately 30 min after filling is completed. Fill flask to within the last millilitre marked on the neck when held at the maximum test temperature and slowly cooled to room temperature (10 to 12 h). Before starting the test, examine the flask for the presence of cavities or irregular contraction of the compound. Some compounds, after cooling below the liquid state, tend to stick to the sides of the neck of the flask. In such cases, it is necessary to gradually warm the neck and flow the compound to meet the rest, after which the flask shall be placed in the bath for several hours to ensure temperature equilibrium.

26.2 With the compound satisfactorily placed in the flask at the lowest temperature, read the height of the column in the neck and then slowly heat the bath. Take readings at 5°C (9°F) intervals, holding the bath as constant as possible at each point until no more expansion occurs at that point. Repeat the procedure for each point until maximum temperature is reached.

26.3 *Precautions*—During the test, take temperature readings at top and bottom of the bath to detect any variation. Make readings of the expansion of the compound at intervals long enough to ensure uniform temperature distribution and complete movement of the compound. Until complete liquefaction, the interval shall be 3 to 4 h; after liquefaction, it may be reduced to 30 min.

### 27. Calculation

27.1 After securing the readings over the temperature range desired, plot a curve from the temperature and expansion readings from which the coefficient of expansion shall be calculated, as follows:

$$E = [(V_1 - V)/(T_1 - T)V] + C \quad (4)$$

<sup>7</sup> A Pyrex or quartz glass flask is satisfactory for this purpose.

where:

- $E$  = coefficient of expansion ( $1/T$ ) of the compound,  
 $V$  = original volume occupied by the compound,  $L$ ,  
 $V_1$  = volume at higher temperature occupied by the compound,  $L$ ,  
 $T$  = original temperature,  
 $T_1$  = higher temperature, and  
 $C$  = coefficient of cubical expansion of the glass container. This may be taken as three times the linear coefficient of expansion.

27.2 The coefficient of expansion shall be calculated for three temperature ranges, as follows:

27.2.1 From the minimum temperature at which the measurement was made to 10°C (18°F) below the softening point. This is intended to give the average coefficient for the solid condition.

27.2.2 From 5°C (9°F) above the softening point to 50°C (90°F) above the softening point. This is intended to give the average coefficient for the liquid condition.

27.2.3 From the minimum temperature at which a measurement was made to 50°C (90°F) above the softening point.

## 28. Report

28.1 Report the following information:

28.2 Type of cell used, copy of the volume-temperature curve, temperature ranges as defined in 27.2, and

28.3 Coefficient of expansion corresponding to each of the three temperature ranges.

### TEST METHOD B—USING METALLIC CELL

## 29. Apparatus

29.1 *Metal Cell*—A cell made of steel, consisting of four parts: a cylinder about 63.5 mm (2.5 in.) in internal diameter having a rigid bottom, a metallic gasket, and a cover to which a steel capillary tube is attached. The cell shall have an internal volume of approximately 250 mL. A metallic cell that has been found suitable is described in Annex A1.

29.2 *Oil Bath*—An oil bath as described in 24.2, Test Method A, with the exception that provision shall be made for supporting the metal cell.

## 30. Calibration

30.1 The cell shall be calibrated to determine its volume at various temperatures as follows:

30.1.1 Weigh the assembled cell to determine its tare weight.

30.1.2 Fill the cell with mercury until replacing the cover causes some to extrude through the capillary tubing. Record the weight of the cell and the mercury and note the temperature.

30.1.3 Place the cell in the oil bath in an inverted position. The capillary tubing should extend over the side of the oil bath in such a way that the extruded mercury may be caught in a beaker. The oil bath, which is several degrees above room temperature, will cause some of the mercury to be extruded from the capillary tube. When all expansion has taken place, weigh the mercury collected.

30.1.4 Adjust the oil bath for other test temperatures and note the amounts of mercury extruded. The weight of the

mercury in the cell at any temperature is thus determined, and the volume may be calculated.

## 31. Procedure

31.1 While filling the cell, place it in an oil bath and maintain at a temperature 50°C (90°F) higher than the softening point of the compound (ring and ball method, as determined in accordance with Section 8). When the cell has been filled to within 6.3 mm (¼ in.) of the cover, place it in a vacuum oven and maintain at a vacuum of 635 mm (25 in.) Hg and a temperature 50°C (90°F) higher than the softening point of the compound for a period of not less than 30 min nor more than 45 min. At the end of this period slowly cool the cell to room temperature, and remove any irregularities in the surface of the compound.

31.2 Screw on the cover and re-weigh the cell and compound.

31.3 Pour sufficient mercury into the cell so that some is extruded when the cover is screwed down. Then weigh the cell again.

31.4 Invert the cell and place in the oil bath, and repeat the procedure prescribed in 30.1.3 and 30.1.4 for 5°C (9°F) intervals.

31.5 *Precautions*—Only clean, distilled mercury shall be used. During the test, take temperature readings at top and bottom of the bath to detect any variation. Readings of the expansion of the compound should be made at time intervals long enough to ensure uniform temperature distribution and complete movement of the compound. Until complete liquefaction of the compound the interval should be 3 to 4 h; after liquefaction, it may be reduced to 30 min.

NOTE 6—**Caution:** Mercury metal vapor poisoning has long been recognized as a hazard in industry. The maximum exposure limits are set by the American Conference of Governmental Industrial Hygienists.<sup>8</sup> The concentration of mercury vapor resulting from use of the above procedure can easily exceed these exposure limits. Mercury, being a liquid and quite heavy, will disintegrate into small droplets and seep into cracks and crevices in the floor if it is spilled. The increased area of exposure adds significantly to the mercury vapor concentration in the air. Mercury vapor concentration is easily monitored using commercially available sniffers. Spot checks shall be made periodically around operations where mercury is exposed to the atmosphere. Thorough checks shall be made after spills. Emergency spill kits are available should the airborne concentration exceed the exposure limits. In addition, exercise care to keep the mercury from the hands. The use of rubber gloves is recommended for handling specimens in the above manner.

## 32. Calculation

32.1 After volumetric determinations have been made over the desired temperature range, plot a curve between volume and temperature readings from which the coefficient of expansion shall be calculated, as follows:

$$E = (V_1 - V)/(t_1 - T)V \quad (5)$$

where:

$E$  = coefficient of expansion ( $1/T$ ) of the compound,

<sup>8</sup> American Conference of Governmental Hygienists, Building D-7, 6500 Glenway Drive, Cincinnati, OH 45211.

$V$  = original volume occupied by the compound,  $L$ ,  
 $V_1$  = volume at higher temperature occupied by the compound,  $L$ ,  
 $T$  = original temperature, and  
 $T_1$  = higher temperature.

32.2 Calculate the coefficient of expansion for the same three ranges as prescribed in Test Method A.

### 33. Report

33.1 Report the following information:

- 33.1.1 Type of cell used,
- 33.1.2 Copy of the volume-temperature curve,
- 33.1.3 Temperature ranges as defined in 27.2, and
- 33.1.4 Coefficient of expansion corresponding to each of the three temperature ranges.

### TEST METHOD C—SPECIFIC GRAVITY METHOD

#### 34. Procedure

34.1 Determine the specific gravity of untreated or degassed compounds at two test temperatures by one or more of the procedures specified in Sections 17-21 applying to the state of the materials at the temperatures between which measurements are desired.

NOTE 7—When the temperature range includes the range over which the material changes from solid to liquid, a true coefficient of expansion cannot be calculated, although for practical purposes this may be done.

#### 35. Calculation

35.1 From the temperature and specific gravity readings, calculate the coefficient of expansion as follows:

$$E = \text{sp gr at } T - \text{sp gr at } T_1 / (T_1 - T) \text{ sp gr at } T_1 \quad (6)$$

where:

$E$  = coefficient of expansion ( $1/T$ ) of the compound,  
 $T$  = initial temperature, and  
 $T_1$  = higher temperature.

#### 36. Report

- 36.1 Report the following information:
  - 36.1.1 Method used,
  - 36.1.2 Temperature ranges used, and
  - 36.1.3 Coefficient of expansion over temperature ranges used.

### TEST METHOD D PYCNOMETER EXPANSION

#### 37. Scope

37.1 This test method is another modification of the specific gravity method (Test Method C) and may also be applied to either untreated or degassed materials. This test method is applicable up to temperatures at which the extruded compound

flows down the side of the flask and cannot be removed with sufficient precision for weighing.

#### 38. Apparatus

38.1 *Flask and Pycnometer*—A 100-mL volumetric heat-resistant glass flask having the zero mark as near as possible to the bulb of the flask and having the neck of the flask cut off at the 100-mL point and ground square. A metal pycnometer may be used provided its coefficient of expansion is known and is applied in the calculation (Section 40).

38.2 *Oil Bath*—An oil bath which may consist of a tall-form heat-resistant glass beaker of sufficient size so that when the flask is supported about 1 in. from the bottom the oil level will reach at least to the zero mark of the flask.

38.3 *Metal Collar*—Lead or iron collars for use on the neck of the flask during heating to prevent oil currents of the bath from moving the flask.

#### 39. Procedure

39.1 Allow the pycnometer to cool slowly to the lowest test temperature. During the cooling period keep the flask filled by adding more compound, and after equilibrium is reached, remove the excess material by passing a sharp, flat blade over the rim. Remove the flask from the bath and quickly weigh. Knowing the tare weight and volume of the flask, the specific gravity may be determined. For successively higher temperatures, it is only necessary to weigh the extruded portion. It is recommended that the extruded compound be cut off by tared single-edge razor blades which can be transferred directly to the balance pan. About 1½ h will generally be required to establish temperature equilibrium.

#### 40. Calculation

40.1 From the temperature and weight readings calculate the coefficient of expansion as follows:

$$E = [(W - W_1)/W_1(T_1 - T)] - (WC/W_1) \quad (7)$$

where:

$E$  = coefficient of expansion ( $1/T$ ),  
 $W$  = initial weight of the compound in the flask, g,  
 $W_1$  = weight of the compound in the flask at higher temperature, g,  
 $T$  = initial temperature,  
 $T_1$  = higher temperature, and  
 $C$  = coefficient of cubical expansion of the flask.

#### 41. Report

- 41.1 Report the following information:
  - 41.1.1 Method used,
  - 41.1.2 Temperature ranges used, and
  - 41.1.3 Coefficient of expansion over temperature ranges used.

## ELECTRICAL TESTS

## DIELECTRIC STRENGTH

**42. Significance and Use**

42.1 Dielectric strength is of importance as a measure of the ability of a compound to withstand electrical stress. It serves to indicate the presence of contaminating materials, such as water, dirt, or conducting particles. It is of value for purposes of comparison or as an indication of the condition of a compound, but it is not a direct measure of the dielectric strength of a compound when subjected to electric stresses in service.

NOTE 8—Should the maximum voltage of the testing equipment be insufficient to produce breakdown under the specified conditions of test, the gap may be set to 1.27 mm (0.05 in.) The dielectric strength with the reduced gap will not be directly comparable with the values determined with the standard gap, and must always be accompanied by a statement of the gap length.

**43. Test Specimens and Electrodes**

43.1 The compound shall be tested between polished hemispherical electrodes 12.7 mm ( $\frac{1}{2}$  in.) in diameter separated by a gap of 2.54 mm (0.100 in.).

NOTE 9—A form of apparatus for holding the electrodes and compound is described in Annex A2.

**44. Procedure**

44.1 Take a representative sample of the material from the original package, melt, and pour directly into the testing container, taking care not to overheat the compound nor to entrap air in it. A melting and pouring temperature of approximately 50°C (90°F) above the softening point is recommended for asphaltic compounds. Thoroughly dry the paperboard test receptacles by heating before using.

44.2 Determine the short-time dielectric strength in accordance with Test Method D 149. Test five specimens at  $25 \pm 5^\circ\text{C}$  and take the average value of the voltage gradient as the short-time dielectric strength of the compound at that temperature. Apply voltage to the test specimens at a uniform rate of increase of 1000 V/s, from zero to breakdown.

**45. Report**

45.1 The report shall be in accordance with Test Method D 149.

**VOLUME RESISTIVITY-TEMPERATURE CHARACTERISTICS****46. Significance and Use**

46.1 The volume resistivity of a compound is a measure of its electrical insulating properties under conditions comparable to those pertaining during the test. High resistivity reflects low content of free ions and ion-forming particles, and normally indicates a low concentration of conductive contaminants.

46.2 The volume resistivity of compounds varies with the temperature, generally decreasing rapidly with increase of temperature. A sufficient number of tests should be made at different temperatures to establish the volume resistivity-

temperature curve. The curve should include tests up to the highest service temperatures. At room temperature and below, the volume resistivity of practically all compounds is so high that it cannot be measured conveniently. The volume resistivity at a specific temperature is useful to detect contamination of the compound in manufacture or use.

**47. Test Specimens and Electrodes**

47.1 A suitable test cell consisting of parallel planes, concentric cylinders, or coaxial cones shall be used in determining the volume resistivity of the compound (see Test Methods D 257). This distance between electrodes shall be not less than 0.75 mm (0.03 in.) nor more than 5 mm (0.2 in.). The area of the electrode shall be sufficiently large so that the current can be measured, with the apparatus available, to an accuracy within 5 %. Electrode areas of 50 to 500 cm<sup>2</sup> (7.7 to 77.5 in.<sup>2</sup>) should prove suitable. Because of possible catalytic or corrosive effects of some compounds on certain metals, the electrodes should be brass-plated nickel, gold, or platinum. The insulating material used to support the electrodes shall be capable of withstanding the wide temperature range to which the cell is subjected, and preferably shall be of an inorganic material such as a ceramic material or suitable glass. A test cell that has been found suitable is described in Annex A3.

**48. Procedure**

48.1 Measure the volume resistivity at each temperature in accordance with Test Methods D 257. Test at 500 volts. The voltage gradient shall not be greater than 1200 V/mm (30 V/mil). Take readings at each test temperature at an electrification time of 1 min. Make a test run with the empty cell over the desired temperature range. If the measured resistance is 100 or more times that obtained subsequently with the filled cell, any error introduced by the cell will be less than 1 % and inconsequential.

48.2 Take a representative sample from the original package, melt, and pour directly into the test cell, taking care not to overheat the compound nor to entrap air in it. A melting and pouring temperature of approximately 50°C (90°F) above the softening point is recommended for asphalts. The quantity of the sample depends upon the capacity of the test cell used, but in any case it shall be sufficient to permit three separate determinations. Before filling, heat the test cell to slightly above the pouring temperature of the compound. A suggested procedure in filling the cell, especially in the case of the higher melting compounds, is to determine the quantity of compound necessary just to fill the cell with the electrodes in position. In the case of coaxial cones or concentric cylinders, first pour the proper quantity of the heated compound slowly into the outer cone or cylinder. Remove any bubbles which may form on the surface of the compound by a quick application of a flame from a bunsen burner. Immediately lower the inner electrode into the compound and place a thermometer in the well.

48.3 Place the test cell, after filling, in an oil or air bath having suitable temperature, control, and allow sufficient time to bring the bath and cell to temperature equilibrium at each test temperature. Determine the temperature of the cell by two

mercury thermometers placed in contact with the electrodes. Determine the temperature of the bath by a mercury thermometer placed near the cell. The temperature of the bath shall be within 1°C (1.8°F) of the sample temperature when readings are taken. Take the temperature of the compound as the average of the readings of the thermometers measuring the temperatures of the inner and outer electrodes when concentric cylinders are used. The temperatures of the cell thermometers shall agree within 0.5°C (0.9°F). In the case of parallel-plane electrodes, when heat can flow to the compound from both sides, an average of the electrode temperatures does not give the true compound temperature unless the electrode temperatures have been constant for a period. Fifteen minutes will be sufficient for a 5-mm layer of most compounds to assume equilibrium when the electrode temperatures differ by 0.5°C (0.9°F) or less.

#### 49. Report

49.1 Report the following information:

- 49.1.1 Type of test cell used,
- 49.1.2 Distance between guarded and unguarded electrodes,
- 49.1.3 Area of the guarded electrode,
- 49.1.4 Applied voltage and time of electrification, and
- 49.1.5 These values are plotted as the logarithm of resistivity as a function of the reciprocal of temperature.

### A-C LOSS CHARACTERISTICS AND PERMITTIVITY (DIELECTRIC CONSTANT)

#### 50. Significance and Use

50.1 The permittivity of a compound indicates the increase in capacitance to be expected when a device is filled with the compound.

50.2 The loss index is a measure of the energy loss in a compound when it is subjected to an alternating electric field.

50.3 When compounds have approximately the same permittivity the dissipation factor is useful for comparison of the relative power loss. Permittivity and dissipation factor are useful in the control of product uniformity. When the compound is used to surround conductors, the loss index should generally be as low as possible, but when it is used in capacitor manufacture a high permittivity and a low dissipation factor are desirable.

50.4 The dielectric properties of solid filling and treating compounds may vary widely with the temperature and frequency of the test. Compounds should be tested at the operating frequency and over a range of temperatures representative of service conditions. Some materials display maxima or minima in a curve of dielectric properties against temperatures. A sufficient number of test temperatures must be used to portray accurately the functional relation.

#### 51. Test Specimens and Electrodes

51.1 For materials tested at low frequencies the same cell used for resistivity tests is applicable and convenient. For materials tested at high frequencies and over a temperature range in which they are always in the solid state, it is preferable

to cast or press a disk or square of the material. Foil electrodes may then be applied to the specimen as described for solid specimens in Test Methods D 150. See Annex A3.

51.2 For measurements at frequencies up to 1 MHz, the test cell shall have a capacitance of not less than 100 pF when filled with the material under test.

#### 52. Procedure

52.1 Determine the permittivity dissipation factor, and loss index in accordance with Test Methods D 150, selecting suitable apparatus for the frequency range of the measurement.

52.2 Take a representative sample from the original package, heat to a temperature approximately 50°C (90°F) above the softening point, and pour it into the preheated cell or mold. A sufficient quantity of sample shall be taken to permit making at least three determinations.

52.3 The voltage gradient shall not exceed 1200 V/mm (30 V/mil). Provide an air or oil bath for the test cell or an air bath for the cast test specimen. Determine the temperatures of the inner and outer electrodes in the case of the cell, or of the upper and lower electrodes in the case of the cast specimen, by thermometers or thermocouples. When using the cell, assume the specimen temperature to be the average of the two electrode temperatures when they agree within 0.5°C (0.9°F) and are substantially constant during a 5-min period, or alternatively during the readings. In the case of parallel plane electrodes when heat can flow to the compound from both sides, an average of the electrode temperatures does not give the true compound temperature unless the electrode temperatures have been constant for a period. Fifteen minutes will be sufficient for a 5-mm layer of most compounds to assume equilibrium when the electrode temperatures differ by 0.5°C (0.9°F) or less.

#### 53. Report

53.1 Report the following information:

- 53.1.1 Type of cell or cast specimen used and the pertinent dimensions,
- 53.1.2 Method and type of apparatus used and the frequency at which the measurements were made,
- 53.1.3 Voltage applied to the specimen during test, and
- 53.1.4 Permittivity dissipation factor and loss index of the specimen at each test temperature.

#### 54. Precision and Bias

54.1 The precision and bias of the methods included herein are not known due to the age of these test methods and the lack of current data.

#### 55. Keywords

55.1 AC loss characteristics; asphaltic compounds; bituminous compounds; coefficient of expansion or contraction; dielectric strength; fire point; flash point; fusible resins; loss on heating; melting point; penetration; permittivity (dielectric constant); softening point; solid filling compounds; solid treating compounds; specific gravity; viscosity; volume resistivity-temperature characteristics; waxes

(Mandatory Information)

**A1. CELL FOR DETERMINING COEFFICIENT OF EXPANSION**

A1.1 Fig. A1.1 shows the metallic cell for coefficient of expansion determinations of solid filling and treating compounds. The cell consists of four principal parts: a steel cylinder, a metallic gasket, a steel cover, and a dummy or auxiliary cover for filling. The gasket must be of a metal which does not amalgamate with mercury.

A1.2 The cylinder is about 63.5 mm (2.5 in.) in internal diameter, and approximately 76 mm (3 in.) in internal depth. The top of the cylinder is threaded to receive the steel cover and has a machined shoulder to seat a 0.076 mm (0.003 in.) thick metallic gasket. The cylinder may be of one-piece construction or fitted with a cap at the bottom similar to the top end.

A1.3 The steel cover is carefully rounded on the under side to avoid air pockets. It is threaded into the top of the cylinder and seats on the metallic gasket. The center of the cover is threaded to receive a steel capillary tube of 0.457 mm (0.018 in.) in internal diameter.

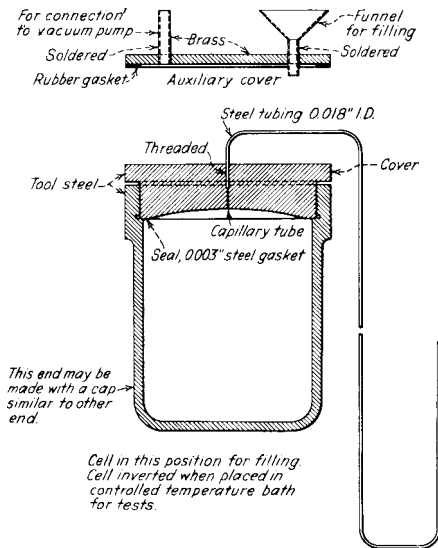

**FIG. A1.1 Metallic Cell for Coefficient of Expansion Determinations**

**A2. DEVICE FOR DETERMINING DIELECTRIC STRENGTH**

A2.1 Because of the great difficulty in removing most solid filling and treating compounds from the container, it is desirable to use a test assembly having an inexpensive container which can be thrown away after a test. A device of this sort is illustrated in Fig. A2.1.

A2.2 The test assembly consists of a framework made from suitable plastic laminate, large enough to hold loosely a box of heavy paper of 2.5 by 3.2 by 4.5-cm (1 by 1/4 by 1 3/4-in.) inside dimensions, with brass bushings centrally inserted in each end piece to hold the electrode rods. The electrodes, which are separable by means of screw joints, are inserted through small holes in the ends of the paper box and clamped to make a compound-tight joint. For the electrodes, a metal is selected that will give minimum gap changes with temperature. Steel has been found quite satisfactory. The proper electrode spacing may be obtained by means of an adjusting screw on the right-hand end.

A2.3 After use, the electrode-supporting screws are backed off; the paper-based container, holding part of the electrodes, is then easily withdrawn. The electrode parts are salvaged by melting the compound, and discarding the used paperboard container.

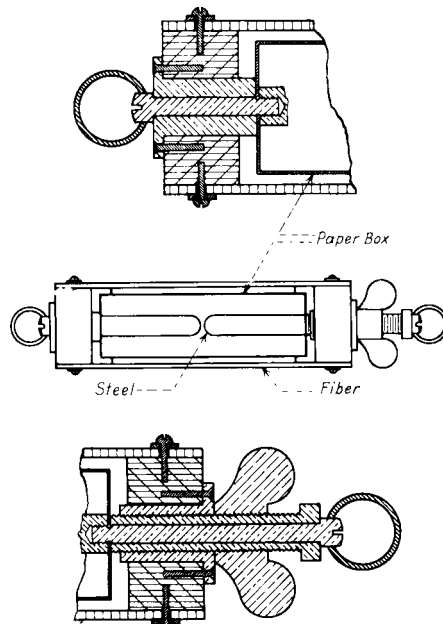

**FIG. A2.1 Container for Dielectric Strength Test Showing Electrodes in Place**

**A3. MEASURING CELL FOR RESISTIVITY, DISSIPATION FACTOR, AND PERMITTIVITY MEASUREMENTS**

A3.1 A conductivity cell that has been developed for the purpose of measuring the volume resistivity as well as other electrical constants of solid filling and treating compounds is shown in Fig. A3.1 The concentric cylinder type of cell was chosen after experimenting with various types for the following points of simplicity and efficiency:

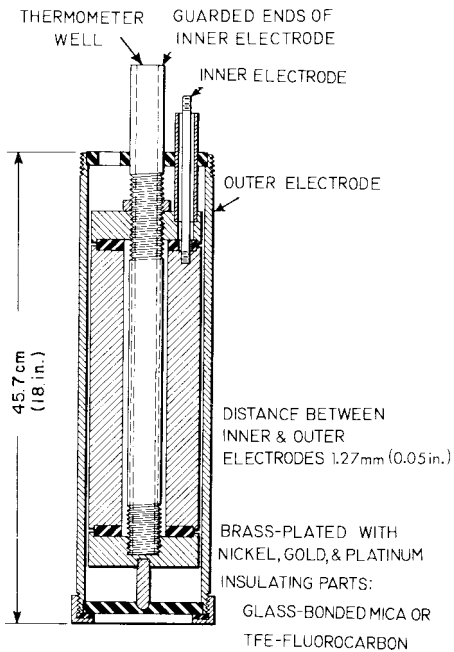

**FIG. A3.1 Measuring Cell for Resistivity, Dissipation Factor, and Dielectric Constant Determinations**

A3.1.1 Ease of insulating electrodes.

A3.1.2 Large area of electrodes in compact form, the outer one of which also serves as container for the compound. This outer electrode is also exposed directly to the heating medium and aids in rapid changes from one temperature to another and also promotes uniform temperature distribution in the comparatively thin layer of compound in contact with it.

A3.1.3 Comparative ease in assembling, disassembling, and cleaning the cell.

A3.2 This type of cell permits the use of a very small amount of insulating material to insulate the electrodes. Glass-bonded mica has been found to be a satisfactory material for this purpose, due to the fact that it can be machined to size and has good insulation-resistance characteristics over the temperature range at which these compounds are normally tested. Also, it apparently is unaffected by the solvents used in the cleaning operation.

A3.3 A suggested method of cleaning the cell is to remove the bottom retaining ring and to hang the cell in an oven by a hook fastened through a hole drilled in the protruding stem. Upon heating, the outer cylinder will slide away from the inner electrode and both parts will drain fairly clean of the compound. In order to speed up this cleaning, the flame of a Bunsen burner may be applied directly to the cell after removing the cap and suspending the cell by the protruding stem. Further application of the flame to the cylinder and inner electrode after they separate will rapidly remove most of the compound, and the final cleaning of each part can be accomplished by suitable solvents.

*The American Society for Testing and Materials takes no position respecting the validity of any patent rights asserted in connection with any item mentioned in this standard. Users of this standard are expressly advised that determination of the validity of any such patent rights, and the risk of infringement of such rights, are entirely their own responsibility.*

*This standard is subject to revision at any time by the responsible technical committee and must be reviewed every five years and if not revised, either reapproved or withdrawn. Your comments are invited either for revision of this standard or for additional standards and should be addressed to ASTM Headquarters. Your comments will receive careful consideration at a meeting of the responsible technical committee, which you may attend. If you feel that your comments have not received a fair hearing you should make your views known to the ASTM Committee on Standards, at the address shown below.*

*This standard is copyrighted by ASTM, 100 Barr Harbor Drive, PO Box C700, West Conshohocken, PA 19428-2959, United States. Individual reprints (single or multiple copies) of this standard may be obtained by contacting ASTM at the above address or at 610-832-9585 (phone), 610-832-9555 (fax), or service@astm.org (e-mail); or through the ASTM website (www.astm.org).*