



Standard Test Method for Thermal Endurance of Flexible Sheet Materials Used for Electrical Insulation by the Curved Electrode Method¹

This standard is issued under the fixed designation D 1830; the number immediately following the designation indicates the year of original adoption or, in the case of revision, the year of last revision. A number in parentheses indicates the year of last reapproval. A superscript epsilon (ϵ) indicates an editorial change since the last revision or reapproval.

This standard has been approved for use by agencies of the Department of Defense.

1. Scope

1.1 This test method provides a procedure for evaluating thermal endurance of flexible sheet materials by determining dielectric breakdown voltage at room temperature after aging in air at selected elevated temperatures. Thermal endurance is expressed in terms of a temperature index.

1.2 This test method is applicable to such solid electrical insulating materials as coated fabrics, dielectric films, composite laminates, and other materials where retention of flexibility after heat aging is of major importance (see Note 4).

1.3 This test method is not intended for the evaluation of rigid laminate materials nor for the determination of thermal endurance of those materials which are not expected or required to retain flexibility in actual service.

1.4 The values stated in acceptable metric units are to be regarded as the standard. The values in parentheses are for information only.

1.5 *This standard does not purport to address all of the safety concerns, if any, associated with its use. It is the responsibility of the user of this standard to establish appropriate safety and health practices and determine the applicability of regulatory limitations prior to use.* For a specific hazard statement, see 10.1.

2. Referenced Documents

2.1 ASTM Standards:

D 149 Test Method for Dielectric Breakdown Voltage and Dielectric Strength of Electrical Insulating Materials at Commercial Power Frequencies²

D 374 Test Methods for Thickness of Solid Electrical Insulation²

D 5423 Specification for Forced-Convection Laboratory Ovens for Evaluation of Electrical Insulation.³

2.2 *Institute of Electrical and Electronics Engineers Publications:*⁴

IEEE No. 1 General Principles for Temperature Limits in the Rating of Electrical Equipment

IEEE No. 101A Guide for the Statistical Analysis of Thermal Life Test Data (including Appendix A)

2.3 *IEC Publications:*

IEC 216 Guide for the Determination of Thermal Endurance Properties of Electrical Insulating Materials (Parts 1 and 2)⁵

3. Terminology

3.1 Definitions:

3.1.1 *temperature index, n*—a number which permits comparison of the temperature/time characteristics of an electrical insulating material, or a simple combination of materials, based on the temperature in degrees Celsius which is obtained by extrapolating the Arrhenius plot of life versus temperature to a specified time, usually 20 000 h.

3.1.2 *thermal life, n*—the time necessary for a specific property of a material, or simple combination of materials, to degrade to a defined end point when aged at a specific temperature.

3.1.3 *thermal life curve, n*—a graphical representation of thermal life at a specified aging temperature in which the value of a property of a material, or a simple combination of materials, is measured at room temperature and the values plotted as a function of time.

3.2 *Definitions of Terms Specific to This Standard:*

¹ This test method is under the jurisdiction of ASTM Committee D-9 on Electrical and Electronic Insulating Materials and is the direct responsibility of Subcommittee D09.07 on Flexible and Rigid Insulating Materials

Current edition approved Oct. 10, 1999. Published November 1999. Originally published as D 1830 – 61T. Last previous edition D 1830 – 94.

² *Annual Book of ASTM Standards*, Vol 10.01.

³ *Annual Book of ASTM Standards*, Vol 10.02.

⁴ Available from the Institute of Electrical and Electronics Engineers, 345 E. 47th St., New York, NY 10017.

⁵ Available from American National Standards Institute, 11 West 42nd St., 13th Floor, New York, NY 10036.

3.2.1 *thermal endurance graph*—a straight-line plot of the logarithm of thermal life in hours versus the reciprocal of the absolute aging temperature in kelvins (also known as the Arrhenius plot).

4. Summary of Test Method

4.1 Specimens are aged in air at a minimum of three temperatures above the expected use temperature of the material. Dielectric breakdown voltage tests in air at room temperature are periodically made to determine the time of aging at each test temperature required to reduce the breakdown voltage to a value of 12 kV/mm (300 V/mil) of original thickness. These thermal life values are used to construct a thermal endurance graph by means of which temperature indices may be estimated corresponding to a thermal life as specified in the material specification or as agreed upon between the user and the supplier.

NOTE 1—This test method is not applicable to materials having an initial dielectric breakdown voltage of less than 12 kV/mm (300 V/mil) of original thickness unless lower endpoint values are agreed upon or indicated in the applicable material specifications.

5. Significance and Use

5.1 A major factor affecting the life of insulating materials is thermal degradation. Other factors, such as moisture and vibration, may cause failures after the material has been weakened by thermal degradation.

5.2 Electrical insulation is effective in electrical equipment only as long as it retains its physical and electrical integrity. Thermal degradation may be characterized by weight change, porosity, crazing, and generally a reduction in flexibility, and is usually accompanied by an ultimate reduction in dielectric breakdown voltage.

6. Apparatus

6.1 *Electrode Test Fixture*—The fixture shall be in accordance with the dimensions shown in Fig. 1 and Fig. 2. Electrodes shall be of polished brass, with the upper electrode having a mass of 1.8 ± 0.05 kg (4.0 ± 0.1 lb).

6.2 *Dielectric Breakdown Test Set*—The set shall meet the requirements of Test Method D 149.

6.3 *Ovens*—Ovens shall meet the requirements of Specification D 5423 Type II.

6.4 *Micrometer*—The micrometer shall be of the dead-weight type specified in Methods C or D of Test Methods D 374, having a pressor foot 6.35 ± 0.03 mm (0.25 ± 0.001 in.) in diameter and an anvil of at least 50 mm (2 in.) in diameter and shall exert a pressure of 0.17 ± 0.01 MPa (25 ± 2 psi) on the anvil.

7. Test Specimens

7.1 Test specimens shall be at least 250 mm (9.84 in.) long by 130 mm (5.12 in.) wide, with the machine direction parallel to the longer direction.

7.2 A set of test specimens consists of five specimens. Prepare one set for initial (unaged) tests and five sets for each aging temperature chosen (15 sets for three temperatures).

7.3 In the case of coated glass fabrics, make tests on 0.18-mm (0.007-in.) material having 0.08-mm (0.003-in.) or 0.10-mm (0.004-in.) base cloth, or on 0.25-mm (0.010-in.) or 0.30-mm (0.012-in.) material having respectively 0.10-mm (0.004-in.) or 0.13-mm (0.005-in.) base cloth.

NOTE 2—Experience has shown that unrealistically extended life data usually result when the base fabrics of glass exceed the thicknesses specified previously for the corresponding coated thicknesses. Similar data are not available for other types of coated fabrics, and the user of this

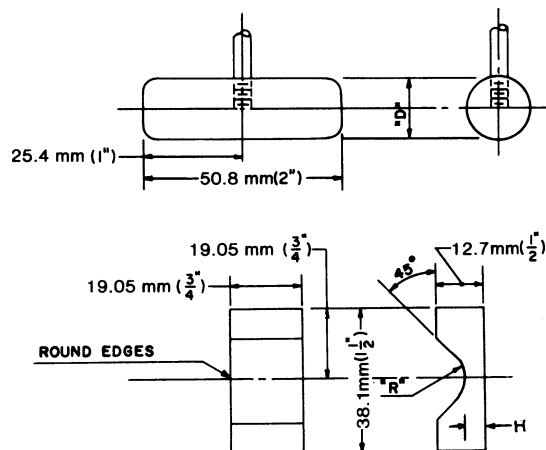

Insulation Thickness		Dimension R		Dimension H		Dimension D	
mm	in.	mm	in.	mm	in.	mm	in.
0.18	0.007	4.55	0.179	8.15	0.321	8.71	0.344
0.25	0.010	6.48	0.255	6.22	0.245	2.45	0.490
0.30	0.012	7.77	0.306	4.93	0.194	4.94	0.588

Tolerance for R and D = ± 0.03 mm (0.001 in.)
 Tolerance for H = ± 0.05 mm (0.002 in.)

FIG. 1 Curved Electrode Details

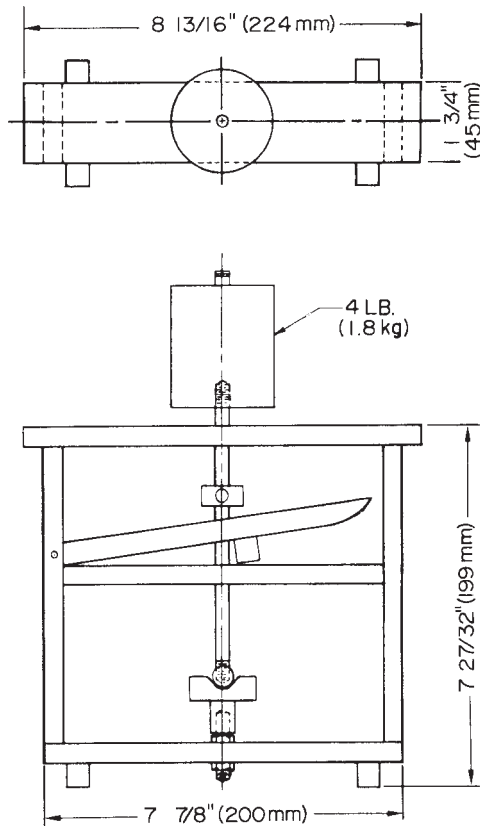

FIG. 2 Curved Electrode and Holder

test method is urged to investigate this relationship to determine similar limitations, if any.

8. Test Specimen Selection

8.1 Select test specimens from the sample in such manner that they are randomly distributed among the sets.

NOTE 3—This can be conveniently accomplished by the following procedure, as an example: In the case of full-width material in rolls or sheets, select an area sufficient to provide a panel about 1 m (3.28 ft) wide by 3 m (9.84 ft) long. Using a suitable marking device, construct a grid of 7 lines spaced 130 mm (5.12 in.) across and 12 lines spaced 250 mm (9.84 in.) down, with an edge margin of about 50 mm (1.97 in.) on each side. This will provide 84 boxes, each delineating a test specimen. Number the boxes consecutively across and down the grid. Using a set of random numbers, obtain a selection of 16 sets of test specimens. In the case of slit material in rolls, number specimens as removed from the roll and obtain a random selection of test sets as in 8.1.

9. Selection of Test Temperatures

9.1 Expose the material at not less than three temperatures. Any temperature that gives a thermal life of less than 100 h is considered too high to be used in this evaluation. Choose the lowest temperature such that (1) a thermal life of at least 5000 h is obtained and (2) it shall not be more than 25°C higher than the estimated temperature index. Exposure temperatures shall differ by at least 20°C.

9.2 Select exposure temperatures in accordance with those shown in Table 1 as indicated by the anticipated temperature index of the material under test. It is recommended that exploratory tests be first made at the highest temperature to obtain data establishing the validity of the 100 h minimum life requirement (see 9.1), and that this be used as a guide for the selection of the lower test temperatures.

10. Procedure

10.1 **WARNING**—Lethal voltages are a potential hazard during the performance of this test. It is essential that the test apparatus, and all associated equipment electrically connected to it, be properly designed and installed for safe operation. Solidly ground all electrically conductive parts which it is possible for a person to contact during the test. Provide means for use at the completion of any test to ground any parts which were at high voltage during the test or have the potential for acquiring an induced charge during the test or retaining a charge even after disconnection of the voltage source. Thoroughly instruct all operators as to the correct procedures for performing tests safely. When making high voltage tests, particularly in compressed gas or in oil, it is possible for the energy released at breakdown to be sufficient to result in fire, explosion, or rupture of the test chamber. Design test equipment, test chambers and test specimens so as to minimize the possibility of such occurrences and to eliminate the possibility of personal injury. If the potential for fire exists, have fire suppression equipment available.

10.2 *Thickness Measurement*—Make 16 thickness measurements before aging, using one specimen from each set prepared. Determine the thickness in accordance with Methods C or D of Test Methods D 374, holding the pressor foot on the specimen for 2 s before taking a reading. Compute the average thickness in millimetres or inches.

10.3 *Dielectric Breakdown Voltage (Unaged)*—Condition one set of specimens for at least 48 h at 23 ± 1°C and 50 ± 2 % relative humidity. Determine the dielectric breakdown

TABLE 1 Suggested Exposure Temperatures and Cycle Durations^A

Cycle Duration, days	Temperatures Corresponding to the Estimated Temperature Index Range, °C													
	Class 105 ^B		Class 130		Class 155		Class 180		Class 200		—			
	100–109	110–119	120–129	130–139	140–149	150–159	160–169	170–179	180–189	190–199	200–209	210–219	220–229	230–239
1	170	180	190	200	210	220	230	240	250	260	270	280	290	300
2	160	170	180	190	200	210	220	230	240	250	260	270	280	290
4	150	160	170	180	190	200	210	220	230	240	250	260	270	280
7	140	150	160	170	180	190	200	210	220	230	240	250	260	270
14	130	140	150	160	170	180	190	200	210	220	230	240	250	260
28	120	130	140	150	160	170	180	190	200	210	220	230	240	250
49	110	120	130	140	150	160	170	180	190	200	210	220	230	240

^A Taken from IEC Publication 216-1.

^B Classes shown correspond to those described in IEEE 1. Materials representative of these classes include: 105-organic varnished cotton cloth, 130-organic varnished glass cloth, 155-polyester coated glass cloth, 180/200-silicone resin and rubber coated glass cloth.

voltage in air at room temperature by the short-time test of Test Method D 149, using a rate of voltage rise of 500 V/s. Make one measurement on each specimen and compute the average dielectric breakdown voltage for the set.

10.4 *Aging of Specimens*—Tag five sets of specimens by any reliably permanent means and expose the sets in the oven at the highest temperature. Position the sets so that free movement of air exists across both sides of the specimens.

NOTE 4—For materials that tend to warp appreciably in heat, specimens may be weighted (in cases where the oven is designed for vertical air movement) or mounted on restraining frames. In either case, the method of restraint shall allow for normal shrinkage during aging and not induce elongation or stress in the specimens. In cases where the specimens become warped, the operator shall endeavor to select portions of the specimens for dielectric breakdown voltage tests so that the electrodes do not prematurely damage the specimens by distortion.

10.5 *Testing of Specimens:*

10.5.1 Remove one set of specimens after completion of the cycle shown in Table 1. Condition the set for 4 h at $23 \pm 1^\circ\text{C}$ and $50 \pm 2\%$ relative humidity.

10.5.2 Immediately make one dielectric breakdown voltage measurement in air at room temperature on each specimen of the set and compute the average breakdown voltage. Return the set to the aging oven.

10.5.3 Remove the same set at the end of the next aging period, condition as prescribed in 10.5.1 and again measure the breakdown voltage on each specimen. Compute the average breakdown voltage for the set, this time discarding the set.

10.5.4 Using this procedure, test the remaining sets until all sets have been tested twice, giving a total of ten average breakdown voltage measurements.

NOTE 5—Normally, the life end point will be reached in ten or less tests if the cycle durations of Table 1 are observed. However, if it appears that ten tests are not sufficient, as indicated by the thermal life curve, arrange to make any further tests in triplicate on each remaining set, thereby extending the aging time.

NOTE 6—Because of the inherent variability of this test, it is prudent to continue testing until the breakdown voltage averages approach 8 kV/mm (200 V/mil) of original thickness.

10.5.5 Using this procedure, repeat testing the remaining sets of specimens at the lower test temperatures.

11. Calculation

11.1 Establish for each temperature the thermal life curve best fitting the plot of average dielectric breakdown voltage in kilovolts versus the exposure time in hours. Determine from this curve the number of hours corresponding to an end point of 12 kV/mm (300 V/mil) of original thickness. End points other than 12 kV (300 V) may be used as specified or as agreed upon.

11.2 Where the experimental points are scattered, making accurate fitting difficult, mathematical fitting, as for example by the method of averaging or the method of least squares, may be helpful. Caution is suggested, however, since some materials exhibit maxima in the breakdown voltage curve due to further curing during aging and erroneous results may be obtained using analytical methods unless there is a knowledgeable preselection of data points to be used. Since interest lies mainly in the later part of the thermal life curve which includes

the end point, selection of experimental data in this vicinity may make possible the use of simple mathematical expressions available in most treatises on empirical curve fitting. On the other hand, if there is a serious scatter of data, it may be prudent to repeat the test.

NOTE 7—Significant curvature in the thermal endurance graph indicates the possibility of deterioration due to other than a single chemical reaction mechanism. Confirm curvature by tests at one or more additional exposure temperatures.

11.3 Plot the thermal life at each exposure temperature on graph paper having as the ordinate a logarithmic time scale and as an abscissa a scale arranged according to the reciprocal of the absolute temperature. In the absence of significant curvature of the data, draw a straight line best fitting the plotted data, continuing this line by extrapolation through the abscissa corresponding to a time limit as specified or as agreed upon. Alternatively, construct a line using the regression analysis technique outlined in IEEE No. 101A.

11.4 Using IEEE No. 101A, compute the 95 % lower confidence limit at the time ordinate specified or agreed upon, expressing this limit in degrees Celsius.

11.5 Determine the temperature index as the temperature in degrees Celsius at which the extrapolated line crosses the time ordinate specified or agreed upon.

12. Report

12.1 Report the following information:

12.1.1 Description of the material, such as type of fabric and coating, nature of composite elements, type of film, nature of adhesives, and average thickness in millimetres or inches,

12.1.2 End point in kV/mm or V/mil of original thickness, if other than that specified in 11.1,

12.1.3 A thermal life curve for each temperature, including the results of dielectric breakdown voltage tests for the unaged set of specimens,

12.1.4 A graph of thermal life on a logarithmic scale as a function of the reciprocal of the absolute temperature (Arrhenius plot),

12.1.5 The temperature index of the material in degrees Celsius corresponding to a life of 20 000 h or as otherwise agreed upon, and

12.1.6 The lower 95 % confidence limit in degrees Celsius corresponding to the life as specified or as agreed upon.

13. Precision and Bias

13.1 This test method has been used for many years, but no information has been presented to ASTM upon which to base a statement of precision. No activity has been planned to develop such information.

13.2 This test method has no bias because the value for thermal endurance is determined solely in terms of this test method itself.

14. Keywords

14.1 curved electrode; dielectric breakdown voltage; flexible sheets; temperature index; thermal endurance; thermal endurance graph; thermal life; thermal life curve

The American Society for Testing and Materials takes no position respecting the validity of any patent rights asserted in connection with any item mentioned in this standard. Users of this standard are expressly advised that determination of the validity of any such patent rights, and the risk of infringement of such rights, are entirely their own responsibility.

This standard is subject to revision at any time by the responsible technical committee and must be reviewed every five years and if not revised, either reapproved or withdrawn. Your comments are invited either for revision of this standard or for additional standards and should be addressed to ASTM Headquarters. Your comments will receive careful consideration at a meeting of the responsible technical committee, which you may attend. If you feel that your comments have not received a fair hearing you should make your views known to the ASTM Committee on Standards, at the address shown below.

This standard is copyrighted by ASTM, 100 Barr Harbor Drive, PO Box C700, West Conshohocken, PA 19428-2959, United States. Individual reprints (single or multiple copies) of this standard may be obtained by contacting ASTM at the above address or at 610-832-9585 (phone), 610-832-9555 (fax), or service@astm.org (e-mail); or through the ASTM website (www.astm.org).