



# Standard Test Methods for Rigid Sheet and Plate Materials Used for Electrical Insulation<sup>1</sup>

This standard is issued under the fixed designation D 229; the number immediately following the designation indicates the year of original adoption or, in the case of revision, the year of last revision. A number in parentheses indicates the year of last reapproval. A superscript epsilon (ε) indicates an editorial change since the last revision or reapproval.

*This standard has been approved for use by agencies of the Department of Defense.*

## 1. Scope

1.1 These test methods cover procedures for testing rigid electrical insulation normally manufactured in flat sheet or plate form. They are generally used as terminal boards, spacers, voltage barriers, and circuit boards.

NOTE 1—For tests applying to vulcanized fibre reference should be made to Test Methods D 619.

NOTE 2—This standard resembles IEC 60893-2, Specification for Rigid Industrial Laminated Sheets Based On Thermosetting Resins for Electrical Purpose, Methods of Tests.

1.2 The test methods appear in the following sections:

Test	Sections	ASTM Test Method
Acetone extractable matter	83 to 84	D 494
Arc resistance	47	D 495
Ash	56 to 60	...
Bonding strength	49 to 54	...
Burning rate and flame resistance	61 to 75	...
Compressive strength	25	D 695
Conditioning	—4	D 618
Conditioning	4	D 6054
Dissipation factor	34 to 40	D 669
Dielectric strength	28 to 33	D 149
Expansion (linear thermal)	76	D 696
Flexural properties	12 to 24	D 790
Hardness (Rockwell)	55	D 785
Insulation resistance and resistivity	41 to 46	D 257
Permittivity	34 to 40	D 150
Resistance to impact	26	D 256
Tensile properties	7 to 11	D 638
Thickness	5 to 6	D 374
Tracking resistance	48	D 2132
Warp or twist	77 to 82	...
Water absorption	27	D 570

1.3 The values stated in inch-pound units are to be regarded as the standard. The metric equivalents of inch-pound units given in these test methods may be approximate.

1.4 This is a fire-test-response standard. See Sections 61 through 75, which are the procedures for burning rate and flame resistance.

1.5 *This standard does not purport to address all of the safety concerns, if any, associated with its use. It is the responsibility of the user of this standard to establish appropriate safety and health practices and determine the applicability of regulatory limitations prior to use.* Specific precautionary statements are given in ~~Note 5~~ 31.1 and 61.5.

## 2. Referenced Documents

2.1 *ASTM Standards:*

<sup>1</sup> These test methods are under the jurisdiction of ASTM Committee ~~D-9~~ D09 on Electrical and Electronic Insulating Materials and are the direct responsibility of Subcommittee D09.07 on Flexible and Rigid Insulating Materials.

Current edition approved ~~March~~ November 10, 1996; 2001. Published ~~May~~ January 2002. Originally published as D 229 – 25 T. Last previous edition D 229 – 946.

- D 149 Test Method for Dielectric Breakdown Voltage and Dielectric Strength of Solid Electrical Insulating Materials at Commercial Power Frequencies<sup>2</sup>
- D 150 Test Methods for ~~A-C~~ AC Loss Characteristics and Permittivity (Dielectric Constant) of Solid Electrical ~~Insulating Materials Insulation~~<sup>2</sup>
- D 256 Test Methods for Determining the Izod Pendulum Impact Resistance of ~~Notched Specimens~~ of Plastics<sup>3</sup>
- D 257 Test Methods for ~~D-C~~ DC Resistance or Conductance of Insulating Materials<sup>2</sup>
- D 374 Test Methods for Thickness of Solid Electrical Insulation<sup>2</sup>
- D 494 Test Method for Acetone Extraction of Phenolic Molded or Laminated Products<sup>4</sup>
- D 495 Test Method for High-Voltage, Low-Current, Dry Arc Resistance of Solid Electrical Insulation<sup>2</sup>
- D 570 Test Method for Water Absorption of Plastics<sup>3</sup>
- D 617 Test Method for Punching Quality of Phenolic Laminated Sheets<sup>2</sup>
- ~~D 618 Practice for Conditioning Plastics and Electrical Insulating Materials for Testing~~<sup>3</sup>
- ~~D 619 Test~~ 619 Test Methods for Vulcanized Fibre Used for Electrical Insulation<sup>2</sup>
- D 638 Test Method for Tensile Properties of Plastics<sup>3</sup>
- D 669 Test Method for Dissipation Factor and Permittivity Parallel with Laminations of Laminated Sheet and Plate Materials<sup>2</sup>
- D 695 Test Method for Compressive Properties of Rigid Plastics<sup>3</sup>
- D 696 Test Method for Coefficient of Linear Thermal Expansion of Plastics Between -30°C and 30°C With a Vitreous Silica Dilatometer<sup>3</sup>
- D 785 Test Method for Rockwell Hardness of Plastics and Electrical Insulating Materials<sup>3</sup>
- D 790 Test Methods for Flexural Properties of Unreinforced and Reinforced Plastics and Electrical Insulating Materials<sup>3</sup>
- D 792 Test Methods for Density and Specific Gravity (Relative Density) of Plastics by Displacement<sup>3</sup>
- D 883 Terminology Relating to Plastics<sup>3</sup>
- D 1674 Methods of Testing Polymerizable Embedding Compounds Used for Electrical Insulation<sup>4</sup>
- D 1711 Terminology Relating to Electrical Insulation<sup>2</sup>
- D 1825 Practice for Etching and Cleaning Copper-Clad Electrical Insulating Materials and Thermosetting Laminates for Electrical Testing<sup>2</sup>
- D 2132 Test Method for Dust-and-Fog Tracking and Erosion Resistance of Electrical Insulating Materials<sup>2</sup>
- D 2303 Test Methods for Liquid-Contaminant, Inclined-Plane Tracking and Erosion of Insulating Materials<sup>2</sup>
- D 3487 Specification for Mineral Insulating Oil Used in Electrical Apparatus<sup>5</sup>
- D 5032 Practice for Maintaining Constant Relative Humidity by Means of Aqueous Glycerin Solutions<sup>6</sup>
- D 6054 Practice for Conditioning Electrical Insulating Materials for Testing<sup>6</sup>
- E 197 Specification for Enclosures and Servicing Units for Tests Above and Below Room Temperature<sup>7</sup>

### 2.2 IEC Standard:

IEC 60893-2 Specification for Rigid Industrial Laminated Sheets Based on Thermosetting Resins for Electrical Purpose, Methods of Tests<sup>8</sup>

## 3. Terminology

3.1 *Definitions*—Rigid electrical insulating materials are defined in these test methods in accordance with Terminology D 883. The terminology applied to materials in these test methods shall be in accordance with the terms appearing in Terminologies D 883 and D 1711.

### 3.2 *Definitions of Terms Specific to This Standard:*

3.2.1 In referring to the cutting, application, and loading of the specimens, the following terms apply:

3.2.1.1 *crosswise (CW), adj*—in the direction of the sheet at 90° to the lengthwise direction. This is normally the weakest direction in flexure. For some materials, including the raw materials used for manufacture of materials considered herein, this direction may be designated as the cross-machine direction or the weft direction.

3.2.1.2 *edgewise loading, n*—mechanical force applied in the plane of the original sheet or plate.

3.2.1.3 *flatwise loading, n*—mechanical force applied normal to the surfaces of the original sheet or plate.

3.2.1.4 *lengthwise (LW), adj*—in the direction of the sheet which is strongest in flexure. For some materials, including the raw materials used for the manufacture of materials considered herein, this direction may be designated as the machine direction or the warp direction.

<sup>2</sup> Annual Book of ASTM Standards, Vol 10.01.

<sup>3</sup> Annual Book of ASTM Standards, Vol 08.01.

<sup>4</sup> Discontinued; see 1991 Annual Book of ASTM Standards, Vol 10.01.

<sup>5</sup> Annual Book of ASTM Standards, Vol 10.03.

<sup>6</sup> Annual Book of ASTM Standards, Vol 10.02.

<sup>7</sup> Discontinued; see 1979 Annual Book of ASTM Standards, Part 40.

<sup>8</sup> For information on tapered pins, see *Kent's Mechanical Engineers' Handbook*, 12th edition, *Design and Production Volume*, Section 15, p. 14.

<sup>8</sup> Available from American National Standards Institute, 25 W. 43rd St., 4th Floor, New York, NY 10036.

3.2.2 In referring to bonding strength, the following term applies:

3.2.2.1 *bonding strength, n*—the force required to split a prescribed specimen under the test conditions specified herein.

#### 4. Conditioning

4.1 The properties of the materials described in these test methods are affected by the temperature and moisture exposure of the materials to a greater or lesser extent, depending on the particular material and the specific property. Control of temperature and humidity exposure is undertaken to: (1) obtain satisfactory test precision, or (2) study the behavior of the material as influenced by specific temperature and humidity conditions.

4.2 Unless otherwise specified in these test methods or by a specific ASTM material specification, or unless material behavior at a specific exposure is desired, condition test specimens in accordance with Procedure A of Practice ~~D 618~~ D 6054 and test in the Standard Laboratory Atmosphere ( $23 \pm 1.1^\circ\text{C}$ ,  $50 \pm 2\%$  relative humidity).

### THICKNESS

#### 5. Apparatus and Procedure

5.1 Measure thickness in accordance with Test Methods D 374.

5.2 On test specimens, the use of a machinist's micrometer as specified in Method B is satisfactory for the determination of thickness for all of the test methods that follow. Where it is convenient, the deadweight dial micrometer, Method C, may be used.

5.3 On large sheets, use Method B. Choose a micrometer with a yoke of sufficient size and rigidity to permit accurate measurements in the center of the sheet.

#### 6. Precision and Bias

6.1 Results of comparative tests in several factories, measuring 36-in. (914-mm) square sheets by a variety of such devices, indicate that the trade is able to measure sheets  $\frac{1}{32}$  and  $\frac{1}{8}$  in. (1 and 3 mm) in thickness to bias accuracy of 0.0015 in. (0.0381 mm). (In the tests,  $\sigma$ , ~~or root mean square deviations~~, of 0.0005 in. (0.0127 mm) ~~were~~ was obtained.)

6.2 This test method has no bias because the value for breaking strength is determined solely in terms of this test method itself.

### TENSILE PROPERTIES

#### 7. Test Specimens

7.1 Machine the test specimens from sample material to conform to the dimensions of sheet and plate materials in Fig. 1.

7.2 Prepare four LW and four CW specimens.

#### 8. Rate of Loading

8.1 The materials covered by these test methods generally exhibit high elastic modulus. Use any crosshead speed provided that the load and strain indicators are capable of accurate measurement at the speed used, except use 0.05 in./min (1 mm/min) in matters of dispute.

#### 9. Procedure

9.1 Measure the tensile strength and elastic modulus in accordance with Test Method D 638 except as modified in the following paragraphs.

9.2 Measure the width and thickness of the specimen to the nearest 0.001 in. (0.025 mm) at several points along the length of the flat section, which is indicated as Dimension F in Fig. 1. Record the minimum values of cross-sectional area so determined.

9.3 Place the specimen in the grips of the testing machine, taking care to align the long axis of the specimen and the grips with an imaginary line joining the points of attachment of the grips to the machine. Allow 0.25 in. (6.3 mm) between the ends of the gripping surfaces and the shoulders of the fillet of the flat test specimen; thus, the ends of the gripping surfaces should be the indicated distance apart, as shown in Fig. 1, at the start of the test. Tighten the grips evenly and firmly to the degree necessary to prevent slippage of the specimen during the test, but not to the point where the specimen would be crushed.

9.4 *Tensile Strength*—Set the rate of loading. Load the specimen at the indicated rate until the specimen ruptures. Record the maximum load (usually the load at rupture).

9.5 *Elastic Modulus*—When elastic modulus is desired, use a load-extension recorder with appropriate extension transmitter and proceed as in 9.3. Attach the extension transmitter, and proceed as in 9.4.

#### 10. Report

10.1 Report the following information:

10.1.1 Complete identification of the material tested,

10.1.2 Type of test specimen (I or II),

10.1.3 Conditioning if other than specified,

10.1.4 Speed of testing,

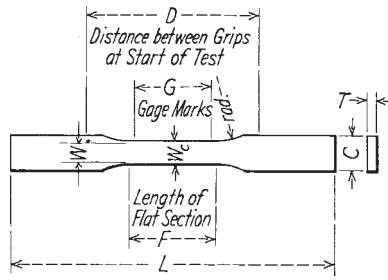

Dimension	Nominal Thickness, <i>T</i>										Tolerance	
	¼ in. (6 mm) or Under				Over ¼ in. (6 mm) to ½ in. (13 mm), incl				Over ½ in. (13 mm) to 1 in. (25 mm), incl <sup>A</sup>			
	Type I		Type II <sup>B</sup>		Type I		Type II <sup>B</sup>		Type I			
	mm	in.	mm	in.	mm	in.	mm	in.	mm	in.	mm	in.
C—Width over-all	19.05	0.750	19.05	0.750	28.57	1.125	28.57	1.125	38.10	1.500	±0.40	+ 0.016
W—Width of flat section	12.70	0.500	6.35	0.250	19.05	0.750	9.52	0.375	25.40	1.000	+ 0.12	+ 0.005
F—Length of flat section	57.1	2.25	57.1	2.250	57.1	2.25	57.1	2.25	57.1	2.25	±0.40	±0.016
G—Gage length <sup>C</sup>	50.8	2.00	50.8	2.00	50.8	2.00	50.8	2.00	50.8	2.00	±0.40	±0.016
D—Distance between grips	114	4½	133	5¼	114	4½	133	5¼	133	5¼	±3	±½
L—Length over-all	216	8½	238	9¾	248	9¾	257	10¼	305	12	min	min
Rad.—Radius of fillet	76	3	76	3	76	3	76	3	76	3	min	min

<sup>A</sup> For sheets of a nominal thickness over 1 in. (25.4 mm) machine the specimens to 1 in. (25.4 mm) ± 0.010 in. (0.25 mm) in thickness. For thickness between 1 in. (25.4 mm) and 2 in. (51 mm), machine approximately equal amounts from each surface. For thicker sheets, machine both surfaces and note the location of the specimen with reference to the original thickness.

<sup>B</sup> Use the type II specimen for material from which the Type I specimen does not give satisfactory failures in the gage length, such as for resin-impregnated compressed laminated wood.

<sup>C</sup> Test marks only.

FIG. 1 Tension Test Specimen for Sheet and Plate Insulating Materials

10.1.5 Calculated tensile strength, average, maximum, and minimum in lb/in.<sup>2</sup> (MPa), for LW and CW specimens, respectively,

10.1.6 Calculated elastic modulus when applicable, average, maximum, and minimum in lb/in.<sup>2</sup> (MPa), for LW and CW specimens, respectively, and

10.1.7 Any other tensile property calculated from the measurements obtained.

## 11. Precision and Bias

11.1 This test method has been in use for many years, but no statement for precision has been made and no activity is planned to develop such a statement.

11.2 ~~This test method has no bias is not being made due to because the lack of a standard reference material value for breaking strength is determined solely in terms of this property: test method itself.~~ See Test Method D 638 for a discussion of precision and bias for tensile testing of plastics.

## FLEXURAL PROPERTIES

### 12. Test Specimens

12.1 Test four LW and four CW specimens machined from sample material in accordance with Test Methods D 790.

NOTE 23—Conventional flexure tests in a flatwise direction are not recommended for materials thinner than ½ in. (1 mm) nor in the edgewise direction for materials thinner than ¼ in. (6 mm).

### 13. Rate of Loading

13.1 The materials covered by these test methods generally rupture during flexural testing at small deflections. Therefore, Procedure A (strain rate of 0.01/min) is specified whenever it is desired to obtain the modulus of elasticity. Any crosshead speed that produces failure in no less than 1 min may be used when flexural strength only is desired, provided that the load indicator is capable of accurately indicating the load at the speed used, and except that in all matters of dispute, a crosshead speed that produces the strain rate specified in Procedure A shall be considered to be the referee speed.

### 14. Procedure

14.1 Measure the flexural strength and modulus of elasticity in accordance with Procedure A of Test Methods D 790, except that where modulus of elasticity is desired use a load-deflection recorder with appropriate deflection transmitter.

## 15. Report

- 15.1 Report the following information:
- 15.1.1 Complete identification of the material tested,
  - 15.1.2 Conditioning if other than specified,
  - 15.1.3 Speed of testing if other than Procedure A speed,
  - 15.1.4 Calculated flexural strength, average, maximum, and minimum in lb/in.<sup>2</sup> (MPa), for LW and CW specimens, respectively,
  - 15.1.5 Calculated tangent modulus of elasticity when applicable, average, maximum, and minimum, for LW and CW specimens, respectively, and
  - 15.1.6 Any other flexural property calculated from the measurements obtained.

## 16. Precision and Bias

16.1 This test method has been in use for many years, but no statement for precision has been made and no activity is planned to develop such a statement. ~~A~~

~~16.2 This test method has no bias is not available because of the lack of a standard reference material value for breaking strength is determined solely in terms of this property. test method itself.~~ See Test Methods D 790 for a discussion of precision and bias for testing of flexural properties of plastics.

## FLEXURAL PROPERTIES AT ELEVATED TEMPERATURE

## 17. Scope

17.1 This test method covers the determination of flexural properties at elevated temperature, and as a function of time of exposure to elevated temperature.

## 18. Significance and Use

18.1 This test method provides useful engineering information for evaluating the mechanical behavior of rigid electrical insulation at elevated temperature. When the proper exposure and test temperatures are chosen, depending on the material and end-use operating temperature, the test method may be used as one means of indicating relative thermal degradation of rigid insulating materials.

## 19. Apparatus

19.1 *Testing Machine*—A universal testing machine and accessory equipment in accordance with Test Methods D 790. Apparatus that is exposed to elevated temperature during the test shall be adjusted to function normally at the elevated temperature and, where necessary, accuracy shall be verified by calibration at the test temperature.

19.2 *Test Enclosure*—A test enclosure conforming to the Type I, Grade B, temperature requirements of Specification E 197. The test enclosure may rest on the testing machine table, in which case the top shall have a hole of sufficient size so that adequate clearance is provided for the loading nose, or the test enclosure may rest on a dolly and contain a cradle which is supported by the loading members of the machine.

19.3 *Heat Aging Oven*—A heat aging oven for conditioning specimens at the test temperature for periods of more than 1 h. The oven shall conform to the requirements for Type I, Grade A, units of Specification E 197, except with respect to the time constant.

19.4 *Specimen Transfer Device*—A means of transferring the test specimens from the heat-aging oven to the test enclosure when testing specimens exposed to elevated temperature for periods of more than 1 h. The specimens may be transferred without cooling either in a small mobile transfer oven or wrapped in previously heated ~~asbestos cloth~~ thick pad of heat resistant material.

19.5 *Thermocouple*—Thermocouple made with No. 30 or 28 B & S gage thermocouple calibration wires to determine the temperature of the specimen. Any suitable indicating or recording device shall be used that provides an overall (junction and instrument) accuracy of  $\pm 2^{\circ}\text{C}$ .

## 20. Test Specimen

- 20.1 Test the specimen flatwise and lengthwise and machine from sample material in accordance with Section 12.
- 20.2 Where it is desired to evaluate relative thermal degradation, specimens shall be  $\frac{1}{8}$  in. (3 mm) in nominal thickness.
- 20.3 Fit at least one specimen of each thickness for each sample material with a hole drilled into an edge that rests outside the support to a depth of at least  $\frac{1}{2}$  in. (13 mm). Insert the thermocouple junction in this hole and cement. Use this specimen to determine the temperature of the specimen on the support and the time required to reach the specified temperature for specimens that are tested after 15-min exposure or less.
- 20.4 Test five specimens at each temperature.

## 21. Conditioning

21.1 No special conditioning is required for specimens that are to be tested after more than 1-h exposure at elevated temperature.

## 22. Procedure

22.1 Adjust the rate of loading in accordance with Section 13 and test the specimen in accordance with Section 14.

22.2 Age in the flexural test enclosure the specimens that are to be tested 1 h or less after exposure to elevated temperature.

22.3 Exposures at elevated temperature for 15 min or less shall not include the time (previously determined from the specimen with the thermocouple) that is required for the specimen to reach the specified temperature. Rather, begin exposures for intervals of 15 min or less when the specimen reaches the specified temperature and end when the specified exposure period has expired.

22.4 Age in the heat-aging oven the specimens that are exposed to elevated temperature for more than 1 h. Do not allow the specimens to cool when removed from the heat-aging oven, but rather transfer them in the mobile-transfer oven or wrap them in ~~previously-hatched asbestos cloth~~ heated thick pad of heat resistant material. Place them in the flexural test chamber which has been previously heated to the specified temperature.

22.5 Consider the flexural test enclosure and accessory equipment inside at equilibrium when a dummy specimen fitted with an internal thermocouple, and placed on the supports, has reached the specified temperature, as determined by the thermocouple measurement. Place test specimens in the flexural test enclosure only after equilibrium has been established.

### **23. Report**

23.1 Report all applicable information plus the following:

23.1.1 Temperature at which the specimens were exposed and tested,

23.1.2 Time of exposure, and

23.1.3 Where sufficient measurements are made, a plot of flexural strength as ordinate and time at elevated temperature as abscissa, for each temperature chosen.

### **24. Precision and Bias**

24.1 This test method has been in use for many years, but no statement for precision has been made and no activity is planned to develop such a statement.

24.2 A statement of bias is not available because of the lack of a standard reference material for this property.

## **COMPRESSIVE STRENGTH**

### **25. Procedure**

25.1 Determine the compressive strength in accordance with Test Method D 695, except test four specimens.

## **RESISTANCE TO IMPACT**

### **26. Procedure**

26.1 Determine the resistance to impact in accordance with Test Methods D 256, using Method A or C, whichever is applicable, except test four specimens conditioned in accordance with 4.2 of these test methods.

## **WATER ABSORPTION**

### **27. Procedure**

27.1 Determine the water absorption in accordance with Test Method D 570, except test all sample material for water-soluble matter unless it has been previously demonstrated by test that there is negligible water-soluble matter in the sample. Test four specimens.

## **DIELECTRIC STRENGTH**

### **28. Surrounding Medium**

28.1 Except as noted below, perform tests in a surrounding medium of transformer oil meeting all of the requirements for Type I mineral oil of Specification D 3487. Test at room temperature, unless otherwise specified.

**NOTE 34**—A liquid medium is specified to obtain breakdown of a reasonable size test specimen rather than flashover in the medium. Testing in a liquid medium limits the likelihood of flashover but may not always prevent it, especially with the tapered-pin method.

Transverse tests performed in an air medium will generally result in lower breakdown values than transverse tests performed in the liquid medium. This is particularly true when porous materials are tested. Tests performed in the liquid medium on specimens that have been thermally aged may produce misleading conclusions when change in dielectric strength is utilized as a criterion of thermal degradation.

Transverse tests in air for porous materials and thermally aged materials are encouraged. Various schemes may be utilized for potting or gasketing the electrodes to prevent flashover. Apparatus is being evaluated for use in a standard method for transverse tests in air. See the Surrounding Medium section of Test Method D 149.

28.2 In the special case of material tests on parallel-tapered-pin configuration where breakdown voltages exceed 50 kV special attention must be given to the cleanliness, dryness, and temperature of the surrounding medium. The substitution of dibutyl phthalate for transformer oil has been found to be satisfactory.

**NOTE 45**—Breakdown of the oil above the specified value for the material under test is not necessarily proof that actual specimen breakdown occurred during a parallel-tapered-pin test, since the specimen surface structure and its permittivity will influence the breakdown voltage of a given oil between the tapered pins with specimen in place.

## 29. Electrodes and Test Specimens

29.1 *Transverse Test*—Use ~~two-inch~~ 2-in. (51-mm) diameter electrodes (Type 1 of Test Method D 149) for voltage stress applied perpendicular to the flat side of the specimen. The test specimen shall be of such size that flashover in the oil medium does not occur before specimen breakdown. In general, a 4-in. (102-mm) square will be satisfactory.

29.2 *Parallel Test, Point-Plane Method*—The test specimens shall be  $\frac{1}{2}$  in. (13 mm) in width by 1 in. (25 mm) in length by the thickness of the material. Minimum thickness of the material shall be  $\frac{1}{8}$  in. (3 mm). Using a twist drill with a point angle of 60 to 90°, drill a hole in the approximate center of the 1-in. (25-mm) length in a direction parallel with the flat sides, to a depth of  $\frac{7}{16}$  in. (11 mm), leaving a thickness of  $\frac{1}{16}$  in. (1.6 mm) to be tested. Insert a snug-fitting metal pin electrode, with the end ground to conform with the shape of the drill used in the hole. Place the specimen on a flat metal plate that is at least  $1\frac{1}{2}$  in. (38 mm) in diameter. This plate serves as the lower electrode. Thus, in effect, the material is tested parallel with the flat sides in a point-plane dielectric gap. The diameter of the hole shall be as shown in the following table:

Nominal Thickness of Sheets of Sheets	Nominal Thickness of Sheets	Nominal Hole Diameter for Pin Electrode	Nominal Hole Diameter for Pin Electrode
$\frac{1}{8}$ to $\frac{1}{4}$ in. (3 to 6 mm)		$\frac{1}{16}$ in. (1.6 mm)	
$>\frac{1}{4}$ in. (6 mm)		$\frac{1}{8}$ in. (3 mm)	

### 29.3 *Parallel Test, Tapered-Pin Method:*

29.3.1 *Significance*—Sheet and plate insulation, particularly laminated sheets, are frequently used in service in a manner such that the full thickness of the insulation is exposed to a voltage stress parallel to the flat sides between pin-type inserts. This method (employing tapered-pin electrodes) is recommended, rather than the method in 29.2, when it is desired to simulate the service condition described and when the need for obtaining quantitative dielectric breakdown data is secondary to acceptance and quality control needs.

29.3.2 *Nature of Test*—The tapered-pin electrodes extend beyond the test specimen on both flat sides. Therefore, oil-medium flashover or oil-specimen interface failure may obscure specimen volume dielectric breakdown. This method is suited, consequently, for use primarily as a proof-type test, that is, to determine only that a material will withstand without failure a specified minimum electric stress applied in a prescribed manner under specified conditions. In some limited cases, however, (for example, specimens conditioned in water) it may be possible to employ the tapered-pin method to obtain quantitative specimen dielectric breakdown data. When numerous tests are made, it may prove difficult to maintain the oil-medium in such a condition as to obviate flashover (with specimen in place between pins spaced 1 in. (25 mm) apart) at voltage magnitude above 50 kV. The practical limit, therefore, when using an oil-medium is 50 kV. This limit can be increased to 80 kV by the use of dibutyl phthalate.

29.3.3 *Test Specimens and Electrodes*—The test specimen shall be 2 by 3 in. (50 by 75 mm) by the thickness of the sheet. The electrodes shall be USA Standard tapered pins (such as Morse, Brown & Sharpe, or Pratt & Whitney) having a taper of  $\frac{1}{4}$  in./ft (20 mm/m). For specimen thicknesses up to and including  $\frac{1}{2}$  in. (13 mm), use No. 3 USA Standard tapered pins<sup>9</sup> 3 in. (76 mm) long and having a diameter of  $\frac{7}{32}$  in. (5.6 mm) at the large end. For specimen thicknesses over  $\frac{1}{2}$  in. (13 mm) up to and including 2 in. (51 mm), use No. 4 USA Standard Pins<sup>8-4</sup> 4 in. (102 mm) long having a diameter at the large end of  $\frac{1}{4}$  in. (6 mm). Drill two  $\frac{3}{16}$ -in. (5-mm) diameter holes, centrally located, 1 in. (25 mm) apart, center to center, and perpendicular to the faces of the specimen. Ream the holes to a sufficient depth to allow the pins to extend approximately 1 in. (25 mm) from the small ends of the holes. Insert the electrodes from opposite sides of the specimen, after the conditioning period. Metal spheres of  $\frac{1}{2}$  in. (13-mm) diameter placed on the extremities of the tapered pins may sometimes decrease the tendency to flashover in the oil.

## 30. Conditioning

30.1 Condition five specimens in accordance with Section 4. In the case of the Parallel Test, Tapered Pin Method, tests are usually performed on unconditioned specimens. However, in determining the effects of exposure to moisture or water using this test, Procedure E of Practice ~~D-618~~ D 6054 is recommended.

## 31. Procedure Note 5—Warning: Lethal

31.1 **Warning: Lethal** voltages may be present during this test. It is essential that the test apparatus, and all associated equipment that may be electrically connected to it, be properly designed and installed for safe operation. Solidly ground all electrically conductive parts that any person might come into contact with during the test. Provide means for use at the completion of any test to ground any parts which: were at high voltage during the test; may have acquired an induced charge during the test; may retain a charge even after disconnection of the voltage source. Thoroughly instruct all operators in the proper way to conduct tests safely. When making high voltage tests, particularly in compressed gas or in oil, the energy released at breakdown may be sufficient to result in fire, explosion, or rupture of the test chamber. Design test equipment, test chambers, and test specimens so as to minimize the possibility of such occurrences and to eliminate the possibility of personal injury.

<sup>9</sup> For information on tapered pins, see *Kent's Mechanical Engineers' Handbook*, 12th edition, *Design and Production Volume*, Section 15, p. 14.

31.12 Determine the dielectric strength, dielectric breakdown voltage, and dielectric proof-type test in accordance with Test Method D 149, except as follows: Make the tests perpendicular to or parallel with the flat sides, or both, depending upon whether the stress on the material when in use is to be perpendicular to or parallel with the flat sides, or both.

31.23 Make the tests by either the short-time method, the step-by-step method, or the slow-rate-of-rise method as follows:

31.23.1 *Short-Time Method*—Increase the voltage at the rate of 0.5 kV/s.

31.23.2 *Step-by-Step Method*—Apply the voltage at each step for 1 min and increase it in the following increments:

Breakdown Voltage by Short-Time Method, kV	Increment of Increase of Test Voltage, kV
25 or less	1.0
Over 25 to 50, incl	2.0
Over 50 to 100, incl	5.0
Over 100	10.0

31.23.3 *Slow-Rate-of-Rise Method*—Increase the voltage as follows:

Breakdown Voltage by Short-Time Method, kV	Rate of Test Voltage Rise, V/s
25 or less	17
Over 25 to 50, incl	33
Over 50 to 100, incl	83
Over 100	167

31.34 *Proof-Type Test*—Make the tests by either the step-by-step or the slow-rate-of-rise method as follows:

31.34.1 *Step-by-Step Method*—Starting at the prescribed percentage of the minimum failure voltage as specified in the appropriate material specification, increase the test voltage in 1-min steps. Use test voltage increments of 1.0 kV for starting voltages of 12.5 kV or less, 2.0 kV for starting voltages over 12.5 to 25 kV, inclusive, and 5.0 kV for starting voltages over 25 kV. Hold the test voltage for 1 min at the specified minimum failure voltage.

31.34.2 *Slow-Rate-of-Rise Method*—Starting at the prescribed percentage of the minimum failure voltages specified in the appropriate material specification, increase the test voltage at a uniform rate as indicated until the specified minimum failure voltage is reached. Calculate the slow rate-of-rise, in volts per second, as follows:

$$\text{Slow rate-of-rise, V/s} = (V_f - V_s)/(n \times 60) \quad (1)$$

where:

$V_f$  = specified minimum failure voltage,

$V_s$  = starting voltage, and

$n$  = total number of 1-min steps that would be obtained using the step-by-step method of 31.34.1.

## 32. Report

32.1 Report the following information:

32.1.1 Material identification,

32.1.2 Method used (from Section 29),

32.1.3 Nature of surrounding medium,

32.1.4 Temperature of the solid specimen before applying voltage,

32.1.5 Method of voltage application (from Section 31),

32.1.6 Thickness of the test specimen,

32.1.7 Individual and average dielectric strength values in volts per mil (kilovolts per millimetre) for the Transverse Test and the Parallel Test, Point Plane Method, and

32.1.8 Individual and average dielectric breakdown voltages in kilovolts for the Parallel Test, Tapered Pin Method.

## 33. Precision and Bias

33.1 This test method has been in use for many years, but no statement for precision has been made and no activity is planned to develop such a statement.

33.2 A statement of bias is not available because of the lack of a standard reference material for this property.

## PERMITTIVITY AND DISSIPATION FACTOR

### 34. Apparatus

34.1 *Specimen Holder*—A well-designed specimen holder to support and shield the specimen and provide for connection of the electrodes to the terminals of the measuring apparatus is recommended. Two-terminal and three-terminal holders are described in Test Methods D 150. A specimen holder for use at elevated temperatures is described in Methods D 1674.

34.2 *Measuring Apparatus*—Use a suitable bridge or resonant-circuit apparatus conforming to the requirements of Test Methods D 150. The choice of equipment will depend upon the frequency at which measurements are to be made, and in certain cases upon the applied voltage gradients when such are specified.

### 35. Electrodes (see Note 6)

35.1 Apply electrodes to the specimens. Most of the electrode materials described in Test Methods D 150 are suitable except fired-on silver. Metal foil and conducting silver paint are generally recommended, but only the latter should be used for measurements at elevated temperatures. For laminated thermosetting materials to be tested at 1 MHz, use either metal foil attached by a thin film of petrolatum or conducting silver paint, and the electrodes shall completely cover both sides of the specimen. For testing ultra-thin, that is, up to a thickness of about 0.03 in. (0.75 mm), glass-base laminated thermosetting materials, use only conducting silver paint electrodes. When the same specimen is used for Condition A and for tests after immersion in water, always remove metal foil electrodes and clean off the petrolatum with a suitable solvent before immersion. Silver paint electrodes, on the other hand, are not removed prior to immersion of specimens in water.

NOTE 6—It has been found that satisfactory permittivity and dissipation factor measurements can be made on many sheet materials, particularly at radio frequencies, by the non-contacting electrode techniques (air-gap, liquid displacement, and two-fluid displacement) described in Test Methods D 150 when appropriate test cells and liquids are available. Such methods are permissible when agreed upon by the parties concerned. No electrodes of any kind are then applied directly to the test specimens.

### 36. Test Conditions

36.1 Unless otherwise specified, test two specimens of each material.

36.2 The thickness of the specimens is usually the manufactured thickness of the sheet, but it may be necessary and is permissible to machine very thick specimens down to a usable thickness. Determine the thickness in accordance with Section 5, except in the cases of ultra-thin thermosetting glass-base laminates, calculate the mean effective thicknesses from the mass in grams and density in grams per cubic centimetre of accurately die-cut disks 2.00 in. (50.8 mm) in diameter, as follows:

$$\begin{aligned} \text{thickness} &= (0.01942 \times \text{mass/density}) \text{ in.} \\ &= (0.04933 \times \text{mass/density}) \text{ mm} \end{aligned} \quad (2)$$

Determine the densities of the 2.00-in. disks in accordance with Test Methods D 792.

36.3 Generally, specimens shall be of such size as is practicable with the apparatus used. For measurements at frequencies up to about 1 MHz, it is recommended that the specimens be of such size that the measured capacitances will be in the approximate range from 50 to 150 picofarads (pF). At higher frequencies, smaller specimens giving capacitances of 10 to 30 pF, approximately, will be required.

36.3.1 For laminated thermosetting materials, except as specified in 36.3.2, saw standard rectangular specimens from sheets to the following dimensions for measurements at 1 MHz:

Thickness of Sheet	Thickness of Sheet	Size of Specimen
Up to $\frac{3}{64}$ in. (1.2 mm), incl		2 by 2 in. (50 by 50 mm)
Over $\frac{3}{64}$ in. (1.2 mm) to $\frac{3}{32}$ in. (2.4 mm)		3 by 3 in. (75 by 75 mm)
Over $\frac{3}{32}$ in. (2.4 mm) to $\frac{1}{4}$ in. (6.4 mm)		4 by 4 in. (100 by 100 mm)
Over $\frac{1}{4}$ in. (6.4 mm) to 2 in. (50 mm)		4 by 8 in. (100 by 200 mm)

36.3.2 For ultra-thin thermosetting laminates, particularly of the glass-base type, the specimens for measurements at 1 MHz shall be small disks accurately die-cut from larger 2-in. (50-mm) disks that have been coated previously on both sides with conducting silver paint first air-dried at room temperature, then heated in a circulating-air oven at 50°C for about 30 min, and finally cooled in a desiccator. The recommended specimen diameters are as follows:

Thickness of Sheet	Thickness of Sheet	Diameter of Specimen	Diameter of Specimen
Up to 0.003 in. (0.07 mm), approximately		0.50 in. (12.5 mm)	
Over 0.003 in. (0.07 mm) to 0.010 in. (0.25 mm)		0.75 in. (19.0 mm)	
Over 0.010 in. (0.25 mm) to 0.030 in. (0.75 mm)		1.00 in. (25.4 mm)	

36.4 Unless otherwise specified, clean specimens in accordance with the manufacturer's recommendation prior to application of electrodes and conditioning.

### 37. Conditioning

37.1 The permittivity and loss characteristics, especially at the lower frequencies, of the materials covered by these test methods are significantly affected by conditioning.

37.2 Unless otherwise specified, condition specimens for at least 40 h at 50 % relative humidity, 23°C, immediately prior to performance of the electrical tests.

37.3 When water immersion conditions are specified, at the end of the conditioning period remove each specimen separately, wipe or blot with lint-free absorbent paper towels, and test within approximately 2 or 3 min after removal from the water.

### 38. Procedure

38.1 Measure the permittivity and dissipation factor in accordance with Test Methods D 150, in the Standard Laboratory Atmosphere of  $50 \pm 2\%$  relative humidity,  $23 \pm 1^\circ\text{C}$ . Other temperatures and humidities may be used to meet special requirements. Follow instructions given in manuals provided by manufacturers of testing apparatus employed.

38.2 In the case of the small disk specimens of ultra-thin laminates at 1 MHz, support the specimen directly on the high-voltage terminal of the apparatus and connect the specimen to the low-voltage or ground terminal by means of a small spring bronze clip attached to a banana plug. Place a coin or similar metal disk, smaller than the specimen, between the free end of the clip and the low voltage or ground electrode to improve contact and avoid damage to the specimen. In calculations of the permittivities of these small disk specimens, neglect the correction for edge capacitance.

38.3 When measurements are made at commercial power frequencies, relatively high voltages may have to be used to obtain adequate sensitivity or to meet a requirement that tests be made at a specified voltage gradient on the specimen. The applied voltage shall not exceed the limitations of the instrument used, and must be below the corona starting voltage of the specimen-electrode system.

### 39. Report

39.1 Report the following information:

39.1.1 Description of the material tested, including the thickness,

39.1.2 Specimen size and type of electrodes employed,

39.1.3 Temperature and relative humidity during test,

39.1.4 Permittivity and dissipation factor of each specimen, and the averages, for each test frequency and testing condition, and

39.1.5 Voltage applied to specimen during test.

### 40. Precision and Bias

40.1 This test method has been in use for many years, but no statement for precision has been made and no activity is planned to develop such a statement.

40.2 A statement of bias is not being made due to available because of the lack of a standard reference material for this property.

## INSULATION RESISTANCE AND RESISTIVITY

### 41. Electrodes

41.1 *Electrodes for Volume and Surface Resistance*—Apply air drying or baking conductive silver paint to the test specimen, approximately centered, in accordance with Fig. 2 of Test Methods D 257, with the following dimensions:

$$D_1 = 2 \text{ in. (51 mm)}$$

$$D_2 = 2\frac{1}{2} \text{ in. (63.5 mm)}$$

$$D_3 = 3 \text{ in. (76 mm)}$$

NOTE 7—Some materials may be metal clad. It may be desirable to utilize the metal foil clad to the insulating material for electrodes. In this event, specifications applicable to the specific material should be followed for etching the clad foil into a suitable electrode pattern.

41.2 *Electrodes for Insulation Resistance*—Metal electrodes in accordance with Fig. 3 of Test Methods D 257 for materials  $\frac{1}{32}$  in. (1 mm) or more in thickness, and in accordance with Fig. 1 of Test Methods D 257 for thinner materials, shall be used.

### 42. Test Specimen

42.1 The surface resistance, and therefore also insulation resistance, may be affected by the manner in which the specimen is prepared, cleaned, and handled. Before insertion or application of the electrode, clean each specimen to remove release agents or other surface contaminants that can influence the measurement of resistance. Take care that the cleaning procedure does not have a solvent or swelling action on the material itself. Handle specimens by touching the edges only. Nylon, rayon, or surgical rubber gloves are recommended as a precaution against possible contamination of the specimens.

42.2 *Specimen for Volume and Surface Resistance Test*—The specimen shall be a  $3\frac{1}{2}$ -in. (89-mm) square or disk.

42.3 *Specimen for Insulation Resistance Test*—The specimen shall be a 3 by 2-in. (76 by 51-mm) rectangle for material  $\frac{1}{32}$  in. (1 mm) or more in thickness. For thinner materials, a  $2\frac{1}{2}$ -in. (63.5-mm) wide strip, rectangular in shape, shall be used.

42.4 Test four specimens.

### 43. Conditioning Enclosure

43.1 Use a conditioning enclosure to provide the specified conditions, to support the specimens, and facilitate electrical connections for resistance measurements without introducing shunting resistances that interfere with the measurements.

43.2 *Humidity Test Enclosure*—The specified relative humidity at the specified temperature may be obtained by the use of solutions in accordance with Practice D 5032. Fit the chamber containing the solution with holders to support the specimen and make electrical connection for the resistance measurement. Thermally insulate the chamber to prevent sudden temperature changes that can cause precipitation inside the chamber. Fit the chamber with a small blower or propeller to circulate the air inside. Place the thermally insulated chamber inside an oven maintained at the specified temperature. Fig. 4 illustrates a suitable humidity test enclosure.

43.3 *Constant-Temperature Oven*—The oven used for elevated temperature resistance measurements shall conform to the Grade B requirements of Specification E 197, except for the time constant. Fit the oven with holders to support the specimen and make

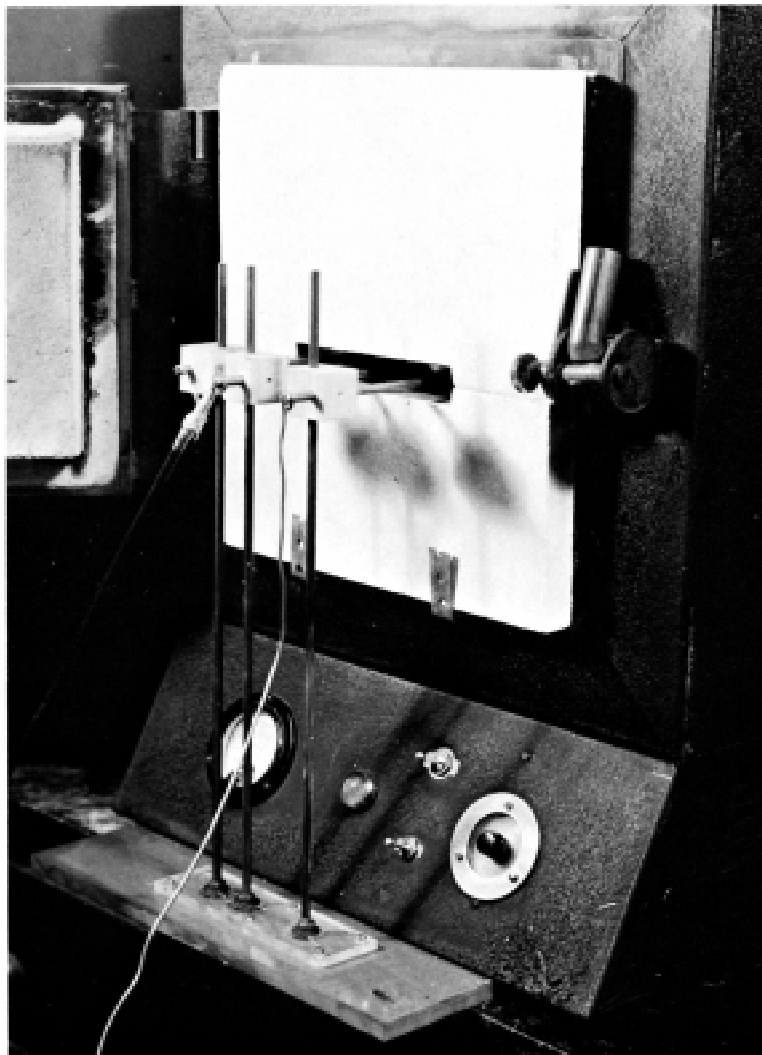

FIG. 2 Insulation Resistance and Resistivity Specimen Holder Brought Through a Split-Type Removable Oven Door

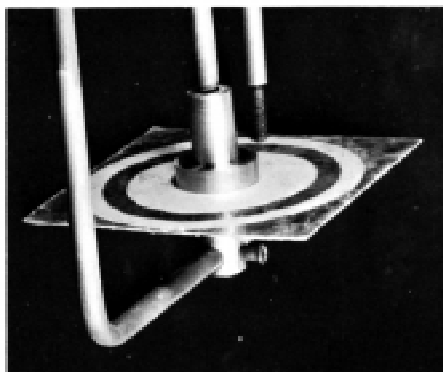

FIG. 3 Test Specimen for Insulation Resistance and Resistivity Tests Mounted in Specimen Holder

electrical connection for the resistance measurements without introducing shunting resistances that interfere with the measurements. Fig. 2 and Fig. 3 illustrate a suitable arrangement.

#### 44. Conditioning

44.1 Resistance properties of materials covered by these test methods are very sensitive to moisture and temperature conditions. Controlled conditioning is required.

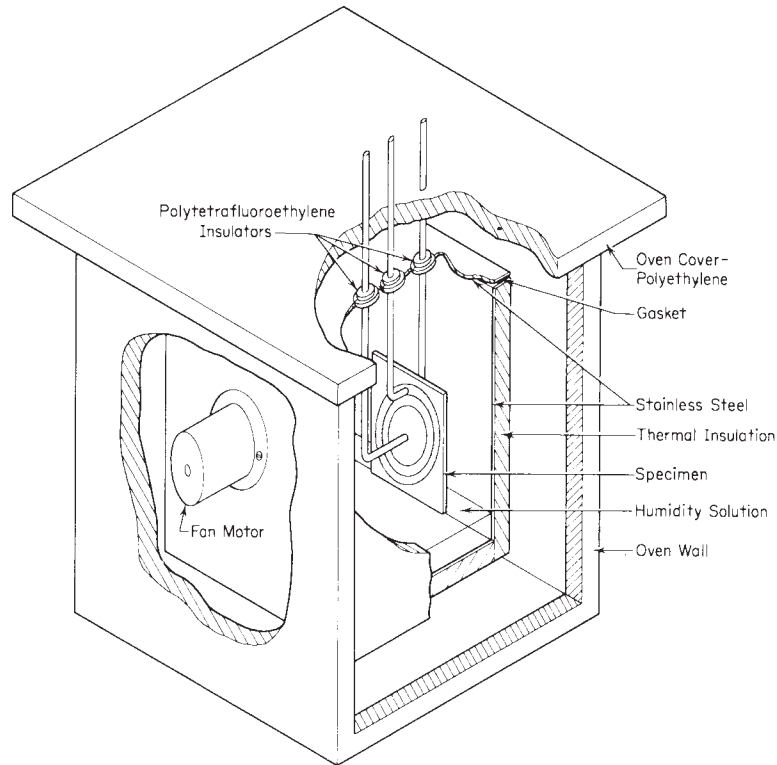

FIG. 4 Humidity Test Enclosure for Insulation Resistance and Resistivity Tests

44.2 Use any controlled condition to obtain the resistance information required. The resistance properties of the materials covered by these test methods are generally so high at fairly dry and room temperature conditions that the resistance values have little, if any, practical engineering significance other than to establish quickly that they are high. The standard conditions recommended for obtaining useful engineering information are as follows:

44.2.1 Procedure C of Practice ~~D 618~~, D 6054, resistance to be measured while the specimen is in the conditioning atmosphere, and the conditioning to be accomplished in a forced-air circulated medium.

44.2.2 Measure the volume resistance of the specimen at the hottest-spot temperature at which the specimen is expected to be used, and 15 min after the specimen has reached and been maintained at this temperature, as determined by means of a thermocouple in the specimen so placed as to measure the temperature of the specimen without interfering with the resistance measurement.

#### 45. Procedure

45.1 Determine the insulation resistance, volume resistance and resistivity, and surface resistance and resistivity in accordance with Test Methods D 257 and as further provided in the following paragraphs.

45.2 At the end of the conditioning period, determine the presence of shunting resistances. If these cannot be effectively eliminated by guarding with the instrumentation used, make proper correction by calculation.

45.3 Measure the resistance of the specimen after applying 500 V of d-c potential difference for 1 min.

#### 46. Precision and Bias

46.1 This test method has been in use for many years, but no statement for precision has been made and no activity is planned to develop such a statement.

46.2 A statement of bias is not available because of the lack of a standard reference material for this property.

### ARC RESISTANCE

#### 47. Procedure

47.1 Determine the arc resistance in accordance with Test Method D 495.

### TRACKING RESISTANCE

#### 48. Procedure

48.1 Determine the dust-and-fog tracking resistance in accordance with Test Method D 2132.

48.2 Determine inclined-plane tracking resistance in accordance with Test Method D 2303 using the variable voltage method.

## **BONDING STRENGTH**

### **49. Significance and Use**

49.1 The bonding strength is a measure of the adhesive strength of a heterogeneous material of the type covered by these test methods. It is useful as a manufacturing control or acceptance test. It may serve to indicate whether or not a thermosetting laminated plastic is properly cured.

### **50. Apparatus**

50.1 Any universal testing machine may be used, provided it is accurate to 1 % of the lowest load to be applied. The machine shall be fitted with a head containing a 10-mm diameter steel ball.

### **51. Test Specimen**

51.1 Any specimen  $\frac{3}{16}$  in. (5 mm) or thicker may be tested. The bonding strength is dependent on specimen thickness, however, and therefore only specimens of the same thickness should be compared.

51.2 The standard specimen shall be  $0.500 \pm 0.005$  in. ( $12.7 \pm 0.127$  mm) thick and 1 in. (25.4 mm) square. Two parallel edges shall be smooth within  $\pm 0.001$  in. ( $\pm 0.025$  mm).

51.3 Test four specimens.

### **52. Procedure**

52.1 Place the specimen with smooth edge on the testing machine table or a flat steel plate that rests on the testing machine table. Accurately center the steel ball between the edges and ends of the specimen.

52.2 Load the specimen through the steel ball, using a crosshead speed not exceeding 0.050 in./min (1.3 mm/min) until the specimen splits. Record the maximum load sustained before or prior to failure.

52.3 Record as the bonding strength the maximum force obtained.

### **53. Report**

53.1 Report the following information:

53.1.1 The thickness of the material, and

53.1.2 The load, expressed in pounds or kilograms, required to split the specimen.

### **54. Precision and Bias**

54.1 This test method has been in use for many years, but no statement for precision has been made and no activity is planned to develop such a statement. ~~This test method has no statement.~~

54.2 ~~A statement of bias is not available because of the value for bonding strength is determined solely in terms lack of a standard reference material for this test method.~~ property.

## **ROCKWELL HARDNESS**

### **55. Procedure**

55.1 Determine the cold Rockwell hardness in accordance with Test Method D 785, except that under Method A use the M scale provided that the total indentation does not exceed the limits of the testing machine. If the total indentation exceeds the limits, use the L scale. Test four specimens.

55.2 Determine the hot Rockwell hardness in accordance with Test Method D 785 and Test Method D 617. Test four specimens.

## **ASH**

### **56. Significance and Use**

56.1 The nature and amount of ash may be of use in determining the continuity of quality and in the interpretation of results of tests for the purposes of design.

### **57. Test Specimen**

57.1 The test specimen shall consist of 2 to 5 g of finely divided particles, such as millings or filings, of the material.

### **58. Procedure**

58.1 Dry the test specimen for 2 h at 105 to 110°C, weigh, then ignite to constant weight in a crucible, and weigh. Calculate the percentage of ash, based on the weight of the dried specimen.

## 59. Report

59.1 Report the following information:

- 59.1.1 The identification of the sample tested, and
- 59.1.2 The percentage ash based on the dry weight of the specimen.

## 60. Precision and Bias

60.1 This test method has been in use for many years, but no statement for precision has been made and no activity is planned to develop such a statement. ~~This test method has no statement.~~

60.2 ~~A statement of bias is not available because of the value for ash content is determined solely in terms lack of a standard reference material for this test method. property.~~

## BURNING RATE AND FLAME RESISTANCE

### 61. Significance and Use

61.1 Rigid electrical insulation is sometimes exposed to temperature sufficiently high to indicate a danger of ignition. This may occur due to malfunction of the apparatus of which the insulation is a part, due to failure of associated equipment in the system, or due to failure of the insulation to resist ignition in normal-usage exposure to electric arcs. It is therefore desirable to provide test methods that allow the relative comparison of the ignition resistance of materials and the extent of burning if ignition does occur.

61.2 Two methods are provided: Burning Rate, Method I, is a relatively simple test that requires inexpensive apparatus. It is intended primarily as a control test and for screening quickly materials that are flame resistant from a population of various types. This method should be used to establish relative burning characteristics of plastic material and should not be used as a fire hazard test. The equipment specified in Method II, which is relatively complex, allows more precise control of test conditions than Method I.

61.3 Neither method will directly produce information from which the performance of the insulating material in service can be quantitatively predicted, since the conditions of use in electrical apparatus are likely to be different than the test conditions. Correlation with flammability under actual use conditions is not implied. The methods do, however, provide means of comparing materials under controlled laboratory conditions.

61.4 Both methods provide for the measurement of resistance to ignition and resistance to continued burning. Method I simply distinguishes between specimens that will ignite (under conditions of the test) from those that will not. Resistance to burning is determined by the time the specimen burns. In Method II, materials may be directly compared for resistance to ignition by determination of ignition time and for burning by the burning time. The comparison of burning, or the tendency of the material to contribute to the spread of fire, requires interpretation regardless of which method is used. Some materials may continue to burn for relatively long periods of time without the dissipation of much heat energy. Other materials, which may burn for relatively shorter periods, may do so with potentially damaging intensity. The determination of weight loss can aid in an interpretation of burning time test results on some materials and may be required by agreement between producer and consumer.

61.5 *This standard should be used to measure and describe the properties of materials, products, or assemblies in response to heat and flame under controlled laboratory conditions and should not be used to describe or appraise the fire hazard or fire risk of materials, products, or assemblies under actual fire conditions. However, results of this test may be used as elements of a fire risk assessment which takes into account all of the factors which are pertinent to an assessment of the fire hazard of a particular end use.*

### *Method— I Burning Rate*

### 62. Apparatus

62.1 *Flame Cabinet*—A draft-free enclosure, test chamber, or hood equipped with an exhaust fan which is controlled by a readily-accessible switch.

62.2 *Supports*—A ring stand with a clamping device for holding test specimens.

62.3 *Burner*—A Tirrill burner having a tube length of 4 in. (100 mm) and an inside diameter of 3/8 in. (9.5 mm). The tube shall have no end attachments such as a flame stabilizer.

62.4 *Gas Supply*—A methane or natural gas supply having a heat content of approximately 1000 Btu/ft<sup>3</sup> (30 kJ/m<sup>3</sup>) and a suitable flow regulator.

62.5 *Timer*—A timepiece or stop watch measuring seconds.

62.6 *Oven*—A forced-ventilation oven maintained at 70 ± 1°C (158 ± 1.8°F).

62.7 *Desiccator*—A desiccator containing anhydrous calcium chloride or equivalent desiccant.

### 63. Test Specimens

63.1 Dimensions of test specimens shall be 5 ± 1/16 in. (12.7 ± 1.6 mm) long by 0.5 ± 0.02 in. (12.7 ± 0.51 mm) wide by the thickness of the sheet. The cut edges of the specimens shall be smooth and free of projecting fibres.

63.2 Cut a total of 20 test specimens without regard to grain direction (unless this is a variable being studied) and divide into two sets of 10 specimens each.

63.3 Test copper-clad specimens with the copper removed by etching in accordance with Practice D 1825.

#### 64. Conditioning

64.1 Condition one set of 10 test specimens for at least 48 h at  $23 \pm 2^\circ\text{C}$  and  $50 \pm 5\%$  relative humidity.

64.2 Condition the other set of 10 specimens for 168 h in an oven at  $70 \pm 1^\circ\text{C}$  and then allow to cool for at least 4 h in a desiccator.

#### 65. Procedure

65.1 Support the test specimen with its 5-in. (128-mm) dimensional axis vertical and clamped within  $\frac{1}{4}$  in. (6.3 mm) of the top at a height such that the lower free end is  $\frac{3}{8}$  in. (9.5 mm) above the top of the burner tube.

65.2 With the burner removed from the specimen, ignite the gas and adjust the flame until it is  $\frac{3}{4}$  in. (19.1 mm) high with a blue color and no yellow tip.

65.3 For each conditioning procedure (see Section 64), test one set of five specimens with the second set of five specimens held in reserve for retesting, if necessary (see 65.6).

65.4 Position the burner centrally below each specimen in the first set selected for each condition, allow to remain for 10 s and then remove. Record the duration of flaming. When flaming ceases immediately replace the burner flame under the specimen for another 10-s interval and then remove. Again record the duration of flaming and of flaming plus glowing.

65.5 Note if the specimen burns completely in either of the two flame applications. (A rating cannot be assigned to the material in this case.)

65.6 If any one specimen in either set of five specimens for each condition fails to comply with the requirements given in Table 1, test a second set of five specimens for that condition. With respect to the total number of seconds of flaming, test an additional set of five specimens if the total is in the range from 51 to 55 s for Class 0 material or in the range from 251 to 255 s for Class 1 material.

#### 66. Report

66.1 Report the following information:

66.1.1 Description of material tested, including thickness and whether the sample was copper-clad, and

66.1.2 The laminate shall be classed as Class 0 or Class 1 if the specimens for both conditioning procedures of Section 64 meet the requirements of Table 1.

### *Method II—Flame Resistance*

#### 67. Terminology

67.1 *Definitions of Terms Specific to This Standard:*

67.1.1 In referring to flame resistance, the following terms apply:

67.1.2 *ignition time (I)*—The elapsed time in seconds required to produce ignition under conditions of this test method.

67.1.3 *burning time (B)*—the elapsed time that the specimen burns after removal of the ignition heat source under conditions of this test method.

#### 68. Apparatus

68.1 *Flame Cabinet*—A metal cabinet with heater coil, spark gaps, specimen holder, access door, and forced-air ventilation as illustrated in Fig. 5, or equipment that gives equivalent results.

68.2 *Control Cabinet*—A control assembly that provides adjustable, regulated power to the heater coils, ignition voltage to the spark gaps, and a timer or timers to indicate the required time intervals as illustrated in Fig. 6.

68.3 *Pyrometer*—An optical pyrometer calibrated to read directly for the emission of Nichrome V, or an optical pyrometer calibrated for black-body emission to which  $6^\circ\text{C}$  is added to the pyrometer reading to obtain the true temperature of the Nichrome

**TABLE 1 Laminate Classes**

	Class 0	Class 1
<i>First application of flame:</i>		
Flaming time for single specimen, s	10	30
<i>Second application of flame:</i>		
Maximum flaming time for a single specimen, s	10	30
Maximum flaming plus glowing time for a single specimen, s	30	60
<i>Both applications of flame:</i>		
Maximum total time of flaming combustion for five specimens in each flame application, s	50	250

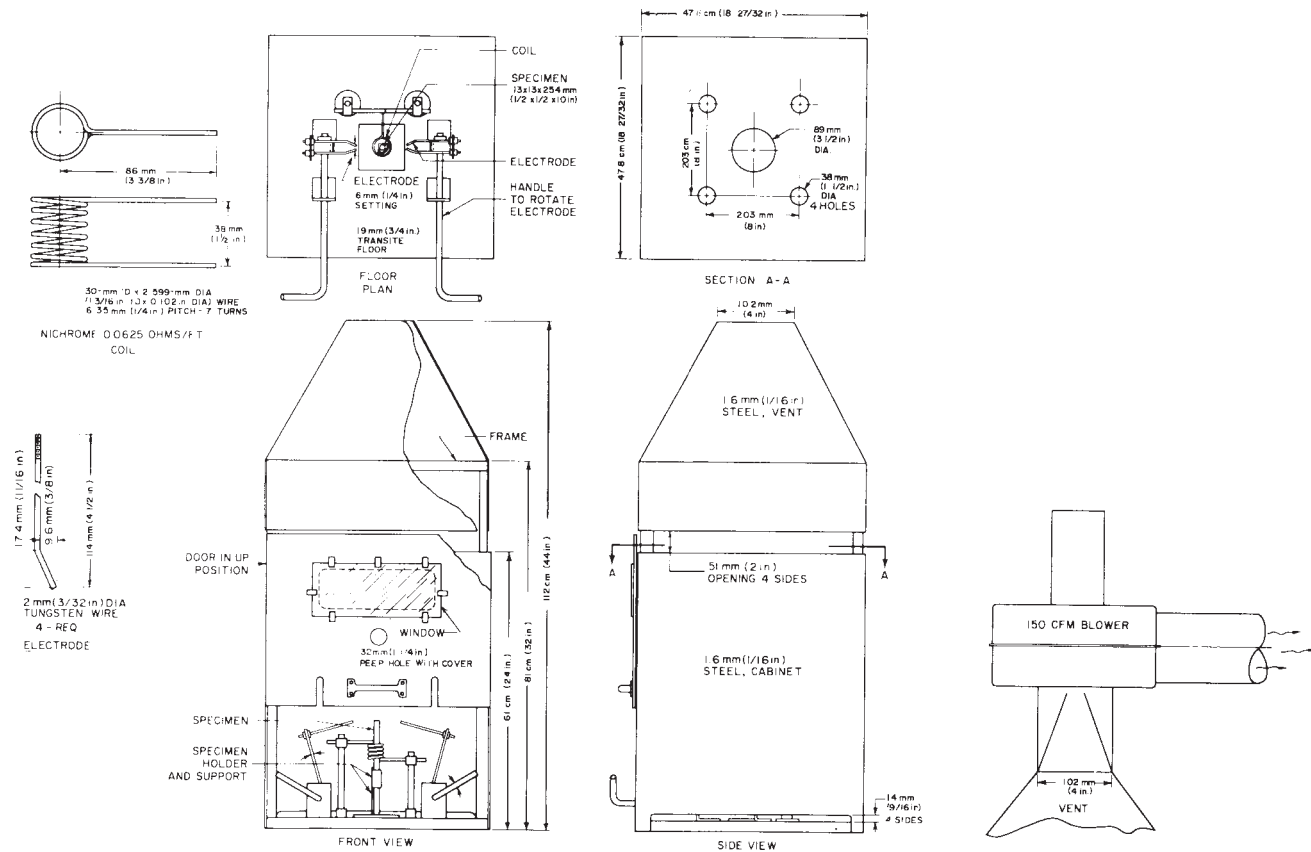

FIG. 5 Flame Cabinet

V coil. The pyrometer shall include a scale for measurement of temperature near 860°C.

68.4 *Coil Form*—A grooved mandrel on which the Nichrome V resistance wire is wound into a heater coil as illustrated in Fig. 7(a).

68.5 *Coil Spacing Gage*—A spacing gage constructed of a sector of a coil form, as illustrated in Fig. 7(b) to check the coil turn-spacing.

### 69. Test Specimen

69.1 The specimen shall be  $\frac{1}{2} \pm 0.036$  in. ( $13 \pm 0.8$  mm) thick or nominal unmachined tolerance by  $\frac{1}{2} \pm 0.01$  in. ( $13 \pm 0.25$  mm) in width by  $10 \pm \frac{1}{16}$  in. ( $254 \pm 1.6$  mm) in length. In cases of molded products, the length of the specimen may be shorter.

69.2 Machine the specimens in a manner that produces a cut surface that is free of projecting fibers and ridges.

69.3 The test sample consists of five test specimens.

### 70. Calibration

70.1 Place a dummy specimen in the holder.

70.2 Adjust the heater coil so that the bottom turn is  $1\frac{1}{2}$  in. (38 mm) above the top of the specimen holder, the coil is symmetrical about the specimen, and the coil height is  $1\frac{1}{2}$  in. (38 mm). Use the coil spacing gage to adjust, if necessary, the individual coil turns for proper spacing.

70.3 Adjust the spark gap to  $\frac{3}{16} \pm \frac{1}{16}$  in. ( $5 \pm 1.6$  mm) and determine that the arc is in an approximate horizontal plane. The total (in both electrodes) arc-current should be  $20 \pm 5$  mA. The electrode tips should be approximately  $\frac{1}{8}$  in. (3 mm) in a horizontal plane from the specimen and  $\frac{1}{2}$  in. (13 mm) above the top turn of the heating coil.

70.4 Remove the dummy specimen. Close the door and energize the ventilating blower. Energize the heating coil and adjust the heater current to approximately 55 A. Allow the coil to come to equilibrium temperature (approximately 120 s). If a new coil is being used, reduce the current to 50 A and allow to remain energized for 24 h to produce a stable oxide coating.

70.5 Open the peep-hole in the door; sight the optical pyrometer on the outside of the middle turn and adjust the heater current to obtain an equilibrium temperature of  $860 \pm 5^\circ\text{C}$ . Keep the peep-hole closed during test.

NOTE 8—After the current has been adjusted, the variable-ratio autotransformer setting must not be disturbed during the test. In order to maintain the temperature within  $\pm 5^\circ\text{C}$ , it is necessary that the average rms voltage across the heater remain constant within  $\pm 1.0\%$ .

### 71. Conditioning

71.1 Condition specimens for 168 h in the Standard Laboratory Atmosphere ( $23^\circ\text{C}$ , 50 % relative humidity) except that when

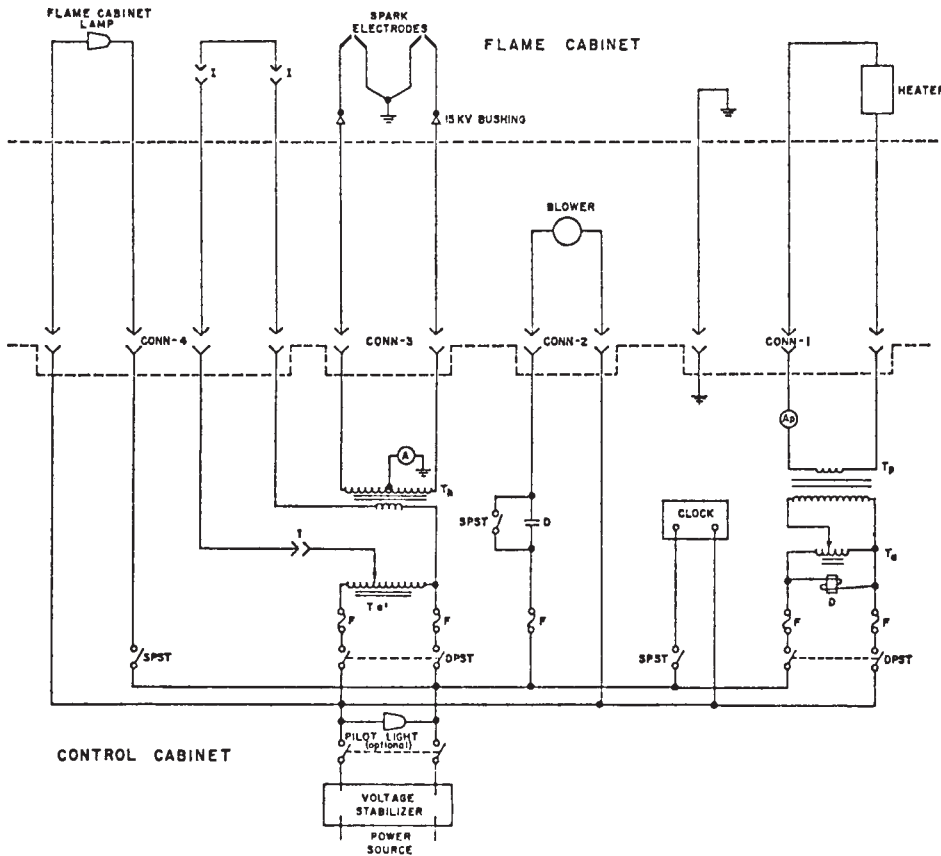

LEGEND:

- A Ammeter, 0-50ma
- Ap Ammeter, 0-100ma
- Ta Variable ratio auto-transformer, 15a
- Te Variable ratio auto-transformer, 500va
- Th HV Transformer, 12/6 kv - 250 va - See note 1
- Tp LV Transformer, 12v - 1.0kva
- D Voltage relay - SPST, NO
- CONN-1 60a - 3pole
- CONN-2 2 Pole
- CONN-3 15kv - 2 pole or use polystyrene board
- CONN-4 4 Pole
- I Mechanical interlock mounted on Flame Cabinet door and Control Cabinet door
- F All fuses slow blow - See note 2

Note 1:  
Alternatively, two 6kv-125va transformers may be used; or a single 6kv-250 va transformer, or 12kv-250 va transformer may be used. In any event, proper circuit connections should be made to obtain 20 ma arc-current, and the ammeter (A) should always be connected to ground.

Note 2:  
Current rating of fuses and CONN-4 is determined by voltage rating of primary power source.

FIG. 6 Electrical Diagram for Control Cabinet

2.8 mm (7/64 in.) GROOVE,  
6.35 mm (1/4 in.) PITCH,  
30 mm (1 3/16 in.) MINOR  
DIAMETER.

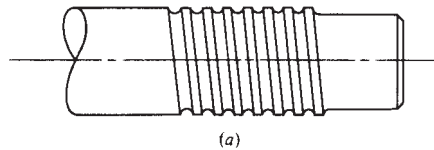

(a)

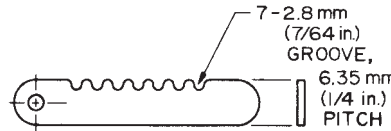

(b)

FIG. 7 Mandrel for Coil (a) and Coil Spacing Gage (b)

it is demonstrated that test results for the specific type material are not significantly affected by conditioning, unconditioned specimens may be used.

71.2 Conduct tests in a room that is controlled at the Standard Laboratory Atmosphere (Note 10) 9) and is free of spurious drafts (Note 10) 9).

NOTE 9—It is a well-established fact that the combustion process is influenced by the moisture content of the oxygen-providing atmosphere.

NOTE 10—Drafts, except those of unusual velocity, are not likely to disturb test conditions when the test is performed with properly constructed apparatus. However, changing drafts are likely to disturb the thermal equilibrium condition so that the heater coil temperature may change from the specified temperature even though constant input power is supplied.

## 72. Procedure

- 72.1 After calibration is completed, use an air jet to cool the coil to room temperature.
- 72.2 Insert the specimen in the holder with the cut side facing the spark gaps. (When testing laminates, make the plane of laminations parallel to the plane of the front of the apparatus.) Close the peep-hole.
- 72.3 Move the arc electrodes to the horizontal position. Energize the ventilating blower.
- 72.4 Simultaneously energize the heater coil, arc gap, and timer circuit.
- 72.5 Record the elapsed time in seconds when the test specimen ignites as ignition time,  $I$ . (Gases released from the specimen may ignite before the specimen commences burning. Ignition time is determined from the instant that the specimen flames rather than from the instant of gas ignition).
- 72.6 De-energize the heater and spark gaps 30 s after the specimen ignites; move the arc electrodes away from the specimen.
- 72.7 De-energize the timer circuit when the specimen ceases to burn (all flame has disappeared), and record the total elapsed,  $T$ , in seconds.
- 72.8 Before beginning the next test, cool the coil with an air jet, brush soot and contamination from the heater coil and arc gaps, and blow any debris from the test enclosure.

## 73. Calculation

- 73.1 *Burning Time*—Calculate the burning time,  $B$ , in seconds, as follows:

$$B = T - I - 30 \quad (3)$$

where:

$T$  = total elapsed time, and

$I$  = ignition time.

Calculate the burning time by arranging the five values of burning time in increasing order of magnitude, as  $T_1, T_2, T_3, T_4$ , and  $T_5$ . Compute the following ratios:

$$(T_2 - T_1)/(T_5 - T_1)$$

and

$$(T_5 - T_4)/(T_5 - T_1)$$

If either of these ratios exceeds 0.642 then  $T_1$  or  $T_5$  is judged to be abnormal and is eliminated. Report the burning time as the average of the remaining four values.

- 73.2 *Average Ignition Time*—Calculate the average ignition time as the arithmetic mean of the five specimens.

## 74. Report

- 74.1 Report the following information:
- 74.1.1 Nominal thickness of the test specimen,
- 74.1.2 Average and individual burning times and ignition times, and
- 74.1.3 Description of how the specimen burns with particular attention to the intensity of the flame.

## 75. Precision and Bias

75.1 This test method has been in use for many years, but no statement for precision has been made and no activity is planned to develop such a statement.

- 75.2 A statement of bias is not available because of the lack of a standard reference material for ~~these properties.~~ this property.

## COEFFICIENT OF LINEAR THERMAL EXPANSION

### 76. Procedure

- 76.1 Test a minimum of two specimens in accordance with Test Method D 696.

### WARP OR TWIST

### 77. Significance and Use

77.1 Warp and twist are expressions of deviation from flatness of a material. The extent of deviation is of interest primarily when it is intended to fabricate the sheet or plate material, but may also affect the ability to use the full-size sheet in an assembly.

### 78. Conditioning

78.1 It is generally not necessary to condition the material. Where conditions of storage may cause warp or twist, condition the material in a manner agreed to by the purchaser and the supplier.

### 79. Procedure

- 79.1 Determine the warp or twist on the sheet in the as-received condition by holding a straightedge along the dimension to be

measured. Place the concave side of the sheet adjacent to the straightedge. Measure the greatest deviation of the concave surface from the straightedge by a metal scale.

79.2 *Warp*—Measure the warp by suspending the sheet freely from the center of one edge in a vertical position against a horizontal straightedge, then in succession by the other edges until the point of maximum warp is obtained.

79.3 *Twist*—Measure the twist by suspending the sheet in a vertical position from adjacent corners, singly and in succession, and then measuring the deviation along the diagonal from the straightedge connecting the corners opposite from the vertical. Report the maximum twist.

## 80. Calculation

80.1 Calculate the percentage warp or twist based on a 36-in. (914-mm) length as follows:

$$W_{914} = (914D/L^2) \times 100 \quad (4)$$

or

$$W_{36} = (36D/L^2) \times 100 \quad (5)$$

where:

$W_{914}$  = percentage warp or twist calculated to a 914-mm length, or

$W_{36}$  = percentage warp or twist calculated to a 36-in. length,

$D$  = maximum deviation in millimetres or inches of the sheet from the straight-edge, and

$L$  = length in millimetres or inches of the dimension along which the warp or twist is measured.

80.2 When it is desired to compare the actual deviation for any length with the permissible deviation for that length, the following equation may be used:

$$D_x/D_{914} = L_x^2/(914)^2 \quad (6)$$

or

$$D_x/D_{36} = L_x^2/(36)^2 \quad (7)$$

where:

$D_x$  = permissible deviation from straight-edge in millimetres or inches for the given length,

$D_{914}$  = permissible deviation in millimetres for 914-mm length, or

$D_{36}$  = permissible deviation in inches for 36-in. length, and

$L_x$  = given length in millimetres or inches.

NOTE 11—These requirements do not apply to cut pieces, but only to sheet sizes as manufactured.

## 81. Report

81.1 Report the following information:

81.1.1 The identification of the sample tested, and

81.1.2 The percent warp or twist based on a 36-in. (914-mm) length.

## 82. Precision and Bias

82.1 This test method has been in use for many years, but no statement for precision has been made and no activity is planned to develop such a statement.

82.2 A statement of bias is not available because of the lack of a standard reference material for this property.

## ACETONE EXTRACTABLE MATTER

### 83. Procedure

83.1 Determine the acetone extractable matter in accordance with Test Method D 494.

### 84. Precision and Bias

84.1 Duplicate determination by different operators should not differ by more than  $\pm 0.5$  % extractable matter for values under 5.0 % and  $\pm 1.0$  % for values 5.0 to 12.0 %.

84.2 This test method has no bias because the value for acetone extractable matter is determined solely in terms of this test method.

### 85. Keywords

85.1 a-c breakdown voltage; arc resistance; ash content; bond strength; compressive strength; dissipation factor; elastic modulus; flame resistance; flexural strength; hard rubber; ~~insulation resistance~~; impact resistance; insulation resistance; permittivity; printed wiring boards; resistivity; rigid plates; rigid sheets; Rockwell hardness; solvent extractible; spacers; surface

resistance; surface resistivity; tensile strength; terminal boards; thermal expansion; thermosetting laminate; thickness; tracking resistance; twist; voltage barriers; volume resistivity; warp; water absorption

*ASTM International takes no position respecting the validity of any patent rights asserted in connection with any item mentioned in this standard. Users of this standard are expressly advised that determination of the validity of any such patent rights, and the risk of infringement of such rights, are entirely their own responsibility.*

*This standard is subject to revision at any time by the responsible technical committee and must be reviewed every five years and if not revised, either reapproved or withdrawn. Your comments are invited either for revision of this standard or for additional standards and should be addressed to ASTM International Headquarters. Your comments will receive careful consideration at a meeting of the responsible technical committee, which you may attend. If you feel that your comments have not received a fair hearing you should make your views known to the ASTM Committee on Standards, at the address shown below.*

*This standard is copyrighted by ASTM International, 100 Barr Harbor Drive, PO Box C700, West Conshohocken, PA 19428-2959, United States. Individual reprints (single or multiple copies) of this standard may be obtained by contacting ASTM at the above address or at 610-832-9585 (phone), 610-832-9555 (fax), or [service@astm.org](mailto:service@astm.org) (e-mail); or through the ASTM website ([www.astm.org](http://www.astm.org)).*