



Standard Classification for Natural Muscovite Block Mica and Thins Based on Visual Quality¹

This standard is issued under the fixed designation D 351; the number immediately following the designation indicates the year of original adoption or, in the case of revision, the year of last revision. A number in parentheses indicates the year of last reapproval. A superscript epsilon (ϵ) indicates an editorial change since the last revision or reapproval.

This standard has been approved for use by agencies of the Department of Defense.

1. Scope

1.1 This classification covers the determination of commercially available natural muscovite block mica and is intended to be independent of the basic color of the mica or its source.

1.2 Muscovite mica is characterized by having an optical axial angle between 50 and 75° (see Appendix X1); and has a weight loss when heated for 5 min at 600°C not exceeding 0.2 % (based on the weight after drying at 120°C).

1.3 The visual system of classifying the quality of natural muscovite mica covered by this specification is based upon relative amounts of visible foreign inclusions such as air bubbles, stains, and spots in combination with relative amounts and types of waviness, as well as other physical properties. In this system, a perfectly clear, transparent, flat specimen of mica is the visual standard of perfection. Increasing amounts of visual defects lower the visual quality, and a total of 13 levels of visual quality are covered by this standard. This method of classification, generally known as the Bengal India System, is purely qualitative and is entirely dependent on personal opinion and judgment.

1.4 The standards for visual quality classification that are covered in this classification are the best commercially available concept of the various qualities and their relative positions. Variations in the methods of using and applying these standards from those herein defined may be specified by the purchaser, or defined by agreement between the supplier and the purchaser.

1.5 Standard size classifications are defined, based upon available usable rectangular areas and the minimum dimensions of the rectangles that the pieces will yield. Precautions to be taken in making thickness measurements are also described.

1.6 This standard covers the following two definite forms of commercial preparation:

1.6.1 *Form 1*—Full-trimmed natural block mica, 0.007 in. (0.178 mm) minimum thickness.

1.6.2 *Form 2*—Partially-trimmed natural block mica, 0.007

in. minimum thickness.

1.7 The basic color of mica, such as white, ruby, light green, dark green, brownish green, and rum, as well as other colors, and the method of controlling the color and other problems associated with the basic color, are not a part of this classification.

1.8 The values stated in inch-pound units are to be regarded as the standard. The values given in parentheses are for information only.

1.9 Section 5 is technically identical to procedures specified in ISO 67.

1.10 Section 6 differs somewhat in procedure from ISO 5972, but data obtained by either should be identical.

1.11 Section 7 is technically identical to procedures specified in ISO 2185.

2. Referenced Documents

2.1 ASTM Standards:

D 374 Test Methods for Thickness of Solid Electrical Insulation²

D 1711 Terminology Relating to Electrical Insulation²

2.2 ISO Publications:

ISO 67-1981 Muscovite Mica Blocks, Thins, and Films—Grading by Size³

ISO 2185-1972 Muscovite Mica Blocks, Thins, and Films—Visual Classification³

ISO 5972-1978 Mica Blocks, Thins, Films, and Splittings—Measurement of Thickness³

3. Terminology

3.1 For definitions of terms relating to mica refer to Terminology D 1711, Part III.

3.2 Terms Specific to This Standard:

3.2.1 “A”—a series of rulings or striations intersecting at an angle of about 60°.

3.2.2 *blocks*—mica thickness of 0.007 in. (0.178 mm) minimum thickness, full-trimmed, unless otherwise designated.

¹ This classification is under the jurisdiction of ASTM Committee D09 on Electrical and Electronic Insulating Materials and is the direct responsibility of Subcommittee D09.19 on Dielectric Sheet and Roll Products.

Current edition approved Sept. 10, 1997. Published February 1998. Originally published as D 351 – 32. Last previous edition D 351 – 85 (1994) ^{ϵ 1}.

² *Annual Book of ASTM Standards*, Vol 10.01.

³ Available from American National Standards Institute, 11 W. 42nd St., 13th Floor, New York, NY 10036.



3.2.3 *buckle*—one or more large depression(s) and elevation(s).

3.2.4 *cracks*—irregular fractures within the crystal that may be natural or may arise from blasting, rough handling, etc.

3.2.5 *full-trimmed mica*—mica trimmed on all sides with all cracks, reeves, and cross-grains removed.

3.2.6 *haircracks or hairline cracks*—minute, irregular cracks that are barely noticeable until mica is split into films, resulting in production of torn films.

3.2.7 *reeves or cross grains*—tangled laminations giving imperfect cleavage, that results in tears or breaks during splitting.

3.2.8 *ribboned or rules mica*—mica that breaks into narrow strips because of parallel fractures.

3.2.9 *ribs or ridges*—crenulations in the form of steps.

3.2.10 *ripple*—multiple short waves.

3.2.11 *stains*—stains arise from foreign materials, resulting in a partial or total loss of transparency. They may be in the form of specks or patches of appreciable area for example, slight stain, “vegetable” stain, clay stain, black stain, red stain, black speckled, light dot or spot, black, red or green dot or spot, etc. (see “inclusions” in Terminology D 1711).

3.2.12 *stones and stone holes*—small embedded crystals or holes resulting from them.

3.2.13 *thins*—knife-dressed mica, 0.002 in. (0.05 mm) to less than 0.007 in. (0.18 mm) in thickness. They may be classified as follows:

3.2.13.1 Thins, 0.002 to 0.004 in. (0.05 to 0.10 mm), and

3.2.13.2 Thick-thins, 0.004 to 0.007 in. (0.10 to 0.18 mm).

3.2.14 *unmanufactured mica*—commercial form of mica known as blocks, thins, films, and splittings, as described.

3.2.15 *waves*—alternate elevations and depressions that may be classified as slight, medium, or heavy.

4. Significance and Use

4.1 The properties included in this standard are those required to control the visual quality, usable area, thickness, hardness, and stiffness.

5. Grading for Size

5.1 *Full-Trimmed*—All full-trimmed mica blocks and thins shall be fully trimmed to remove all cracks, holes, reeves, and cross-grains according to the quality desired. As far as possible, all marginal cracks should be removed by recutting. The average area of the pieces for Grade 4 and larger shall be not more than 1.54 times the average area of the largest usable rectangles. This would constitute a minimum yield of 65 %. For Grades 5 and smaller, the average area of the pieces shall be not more than two times the average area of the largest usable rectangles. This would constitute a yield of 50 %.

5.2 *Half-Trimmed*—For half-trimmed mica, follow the grading described in 5.1 for trimmed sides with no cracks extending from the trimmed sides, except for sizes 6 and 5½ on which only side must be trimmed free of cracks. On the untrimmed sides, no defects of the designated quality are acceptable within the minimum rectangle of the designated grade.

5.3 *Natural Block and Thins*—Natural block and thins, muscovite mica shall be graded for size according to the area

of the rectangle (maximum rectangle for full-trimmed, maximum rectangle of designated quality for half-trimmed) having at least the minimum dimension of one side for the specified grade. The area within such a rectangle shall meet the requirements of the quality specified by the purchaser as listed in Table 1.

5.4 *Method of Grading for Size*—The Standard ASTM Chart shown in Fig. 1 shall be used for grading natural block and thins, muscovite mica according to size. In grading natural block mica and thins for size, all dimensions apply to the smaller surface measured from the foot of the bevel-trimmed edge. The specimen to be graded shall be laid upon the chart so that it covers point O and has its maximum and minimum dimensions extending along and covering lines OA and OB, respectively. The specimen shall be shifted until the usable area completely covers the largest rectangle, determined by a diagonal extending from point O to or beyond a point on any of the curves. The number of the curve at the greatest distance from O cut by the diagonal of the rectangle designates the grade of the specimen.

6. Thickness of Block Mica

6.1 Measure the thickness with a micrometer as specified in Test Methods D 374. In determining thickness of mica that must be kept within small permissible variations, or where two or more specimens are to be measured at once, use Method A of Test Methods D 374. Where the maximum accuracy is not required, Method B may be used.

6.2 Because of the abrasive nature of mica, test the micrometer frequently for conformity to the requirements specified in Test Methods D 374. Clean the anvil and spindle as frequently as necessary to prevent the accumulation of mica dust on the surfaces and to preserve the accuracy of the measurements. To clean, close the micrometer lightly on a clean sheet of bond paper and move the paper between the surfaces.

6.3 Be careful, when moving from one measurement location to another, to maintain the surfaces of the anvil and spindle parallel to the surfaces of the specimen at all times, so as to avoid scratching the mica and accumulating mica dust under the micrometer surfaces, thereby causing false readings.

TABLE 1 ASTM Grade Sizes of Muscovite Uncut Mica Block and Thins

ASTM Grade Sizes	Area of Minimum Rectangle		Minimum Dimension of One Side	
	in. ²	Equivalent, cm ²	in.	Equivalent, mm
OEE Special	100	650	4	100
OEE Special	80	520	4	100
EE Special	60	390	4	100
E Special	48	310	4	100
A-1 (Special)	36	235	3½	89
No. 1	24	155	3	76
No. 2	15	97	2	51
No. 3	10	65	2	51
No. 4	6	40	1½	38
No. 5	3	20	1	25
No. 5½	2¼	15	¾	22
No. 6	1	6.5	¾	19

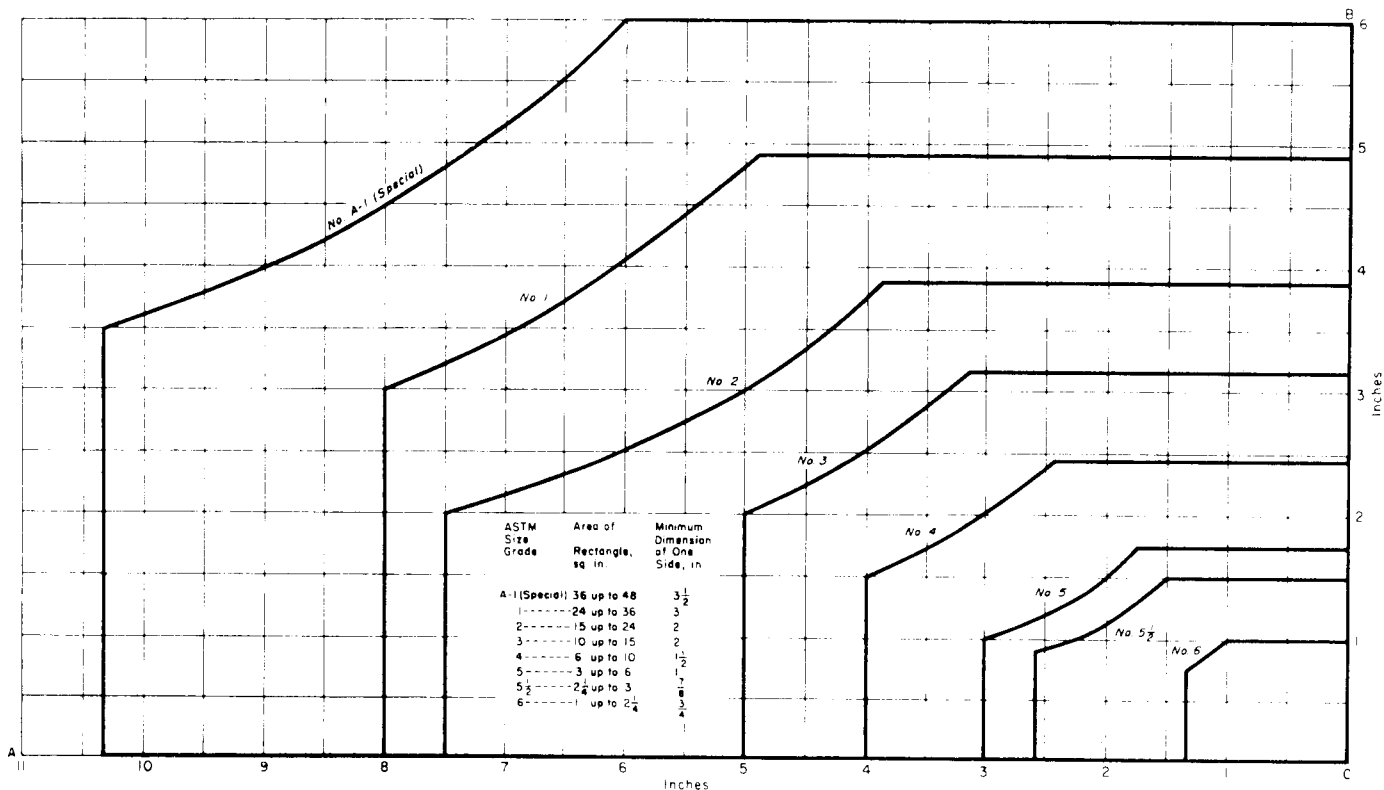

NOTE 1—This chart may be readily extended for Grades OOOE Special, OEE Special, EE Special, and E Special, using the information given in Table 1 of ASTM Specification D 351.

FIG. 1 ASTM Chart for Grading Natural Muscovite Block and Film Mica

7. Classification of Visual Quality of Block Mica

7.1 The classification of the visual quality of muscovite blocks and thins shall fall into the following thirteen categories:

- 7.1.1 V-1 Clear
- 7.1.2 V-2 Clear and Slightly Stained
- 7.1.3 V-3 Fair Stained
- 7.1.4 V-4 Good Stained
- 7.1.5 V-5 Stained A Quality
- 7.1.6 V-5.1 Stained A1 Quality
- 7.1.7 V-6 Stained B Quality
- 7.1.8 V-7 Heavy Stained
- 7.1.9 V-8 Densely Stained

- 7.1.10 V-9 Black Dotted
- 7.1.11 V-10 Black Spotted
- 7.1.12 V-11 Black Stained
- 7.1.13 V-12 Black/Red Stained

7.2 The classification of the visual quality of block mica shall be judged in accordance with the requirements specified in Table 2 using the visual descriptions given.

8. Keywords

8.1 Bengal India System; block; classification; foreign inclusions; form; grading; muscovite mica; size; thins; visual quality



mineral stains not exceeding two specks within the usable area and the entire area may have air inclusions if not heavily concentrated over more than area equivalent to ¼ in. square (6.4 mm square) for grade 5 and up and over more than an area equivalent to ⅙ in.² (3.2 mm²) for grade 5½ and below. Crystallographic discoloration is permitted.

V-6 Stained B Quality—Hard, free of cracks, and other similar defects and foreign inclusions, except may be wavy and slightly buckled and may contain heavy air inclusions, medium vegetable, clay and mineral stains. Crystallographic discoloration is permitted.

V-7 Heavy Stained—Hard, free of cracks and other similar defects and foreign inclusions, except may be wavy and buckled and may contain heavy air inclusions, heavy vegetable and medium mineral stains. Crystallographic discoloration is permitted.

V-8 Densely Stained—May be soft and may contain heavy stains and inclusions, waves, cracks, buckles and other defects. Crystallographic discoloration is permitted.

V-9 Black Dotted—Hard, free of cracks and other similar defects, but may be medium wavy and may contain heavy air inclusions, vegetable stains and dispersed black dots. Crystallographic discoloration is permitted.

V-10 Black Spotted—Hard, free of cracks and similar defects and foreign inclusions, except may be medium wavy and contain slight buckles and vegetable stains, black spotted or red dotted mineral stains, and heavy air inclusions. Crystallographic discoloration is permitted.

V-11 Black Stained—Hard, may contain medium waves, heavy air inclusions, smokey stains, black stains and red dots (mineral), green stains (vegetable type), and sand blast, medium black stains (mineral), slight red stains (mineral) and clay stains. Crystallographic discoloration is permitted.

V-12 Black/Red Stained—V-11 Quality but may be soft and have black lines, or short red bars, or both, or connected stains.

APPENDIX

(Nonmandatory Information)

X1. METHOD OF MEASURING THE OPTICAL AXIAL ANGLE OF MICA

X1.1 Muscovite mica is a monoclinic mineral and can be readily distinguished from phlogopite or biotite by the difference in optical axial angle. When viewed between crossed polarized light, two sets of colored concentric circles crossed by a black cross become visible. The arms of the cross correspond to the vibration directions of the light emitted by the polaroid screens and the rings and zones of equal interference for all rays of light entering at various angles. This is shown diagrammatically in Fig. X1.1(a). If the mineral is rotated, the circles remain constant and the black cross opens out into two hyperbolic curves called “brushes,” as shown in Fig. X1.1(b).

X1.2 The apparatus shown in Fig. X1.2 is capable of measuring the angle between the optic axes by ascertaining the angle of rotation between the “brushes” as defined in X1.1. It is inexpensive to construct and is rapid in operation. The dial mounted on the rotating stage, A, is calibrated in degrees and should be capable of being read to the nearest degree. The upright plate, B, serves to hold a second rotating stage, C, equipped with spring clips to keep the specimen of mica in position. When the specimen is viewed, a series of colored bands will be seen, and these may be made to cross the field parallel to the vertical plane when stage C is rotated. Rotate stage A until a pair of “eyes,” as shown in Fig. X1.1(a), is

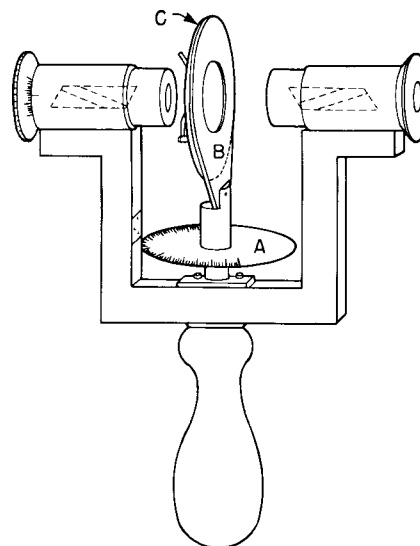

FIG. X1.2 Polariscope for Measuring Optical Axial Angle of Mica

located. The optic axial figure and the bands will now be a series of circles with one of the hyperbolic “brushes” passing through the center of the innermost circle. Arrange this black line so that it stands vertically in the center of the field. Record the reading of the dial on stage A. Rotate stage A until the second brush is in the center of the field and again record the reading of the dial. The difference between the two settings gives the angle between the optic axes. The thicker the sheet of mica, the more numerous are the circles in each eye and the more distinct the “brush.”

X1.3 Monochromatic light is generally more suitable for making these determinations, but daylight will produce results which are accurate enough for the purposes of this specification.

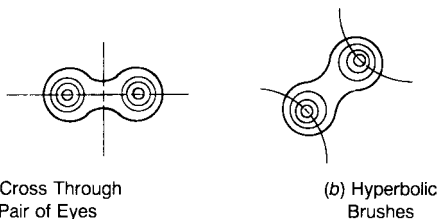

FIG. X1.1 Diagrams in Measuring Optical Axial Angle of Mica

**NOTICE: This standard has either been superceded and replaced by a new version or discontinued.
Contact ASTM International (www.astm.org) for the latest information.**



ASTM International takes no position respecting the validity of any patent rights asserted in connection with any item mentioned in this standard. Users of this standard are expressly advised that determination of the validity of any such patent rights, and the risk of infringement of such rights, are entirely their own responsibility.

This standard is subject to revision at any time by the responsible technical committee and must be reviewed every five years and if not revised, either reapproved or withdrawn. Your comments are invited either for revision of this standard or for additional standards and should be addressed to ASTM International Headquarters. Your comments will receive careful consideration at a meeting of the responsible technical committee, which you may attend. If you feel that your comments have not received a fair hearing you should make your views known to the ASTM Committee on Standards, at the address shown below.

This standard is copyrighted by ASTM International, 100 Barr Harbor Drive, PO Box C700, West Conshohocken, PA 19428-2959, United States. Individual reprints (single or multiple copies) of this standard may be obtained by contacting ASTM at the above address or at 610-832-9585 (phone), 610-832-9555 (fax), or service@astm.org (e-mail); or through the ASTM website (www.astm.org).