



Designation: D 3874 – 9703

An American National Standard

Standard Test Method for Ignition of Materials by Hot Wire Sources¹

This standard is issued under the fixed designation D 3874; the number immediately following the designation indicates the year of original adoption or, in the case of revision, the year of last revision. A number in parentheses indicates the year of last reapproval. A superscript epsilon (ϵ) indicates an editorial change since the last revision or reapproval.

1. Scope

1.1 This test method is intended to differentiate, in a preliminary fashion, among materials with respect to their resistance to

¹ This test method is under the jurisdiction of ASTM Committee D09 on Electrical and Electronic Insulating Materials and is the direct responsibility of Subcommittee D09.212 on Fire Performance Standards—Electrical Tests.

Current edition approved ~~Sept. 10, 1997~~; Oct. 1, 2003. Published November ~~1997~~; 2003. Originally approved in 1988. Last previous edition approved in 1990₇ as D 3874 – 90_{a7}.

ignition because of their proximity to electrically-heated wires and other heat sources.²

1.2 This test method applies to molded or sheet materials available in thicknesses ranging from 0.25 to 6.4 mm (0.010 to 0.25 in.).

1.3 This test method applies to materials that are rigid at normal room temperatures. That is, it applies to materials for which the specimen does not deform during preparation, ~~including~~ especially during the wire-wrapping step described in ~~9~~ 10.1. Examples of deformation that render this test method inapplicable include:

1.3.1 Bowing, in either a transverse or a longitudinal direction, or twisting of the specimen, during the wire-wrapping step, to a degree visible to the eye.

1.3.2 Visible indentation of the wrapped wire into the specimen.

1.4 The values stated in SI units are to be regarded as the standard. The inch-pound units given in parentheses are for information only. (See IEEE/ASTM SI-10 for further details.)

1.5 This test method measures and describes the response of materials, products, or assemblies to heat and flame under controlled conditions, but does not by itself incorporate all factors required for fire hazard or fire risk assessment of the materials, products, or assemblies under actual fire conditions.

1.6 *This standard does not purport to address all of the safety concerns, if any, associated with its use. It is the responsibility of the user of this standard to establish appropriate safety and health practices and determine the applicability of regulatory limitations prior to use.*

1.7 Fire testing of products and materials is inherently hazardous, and adequate safeguards for personnel and property shall be employed in conducting these tests. Fire testing involves hazardous materials, operations, and equipment.

NOTE 1—Although this test method and IEC 60695-2-20, differ in approach and in detail, data obtained using either are technically equivalent.

2. Referenced Documents

2.1 ASTM Standards:³

D 1711 Terminology Relating to Electrical Insulation

E 176 Terminology of Fire Standards

IEEE/ASTM SI-10 International System of Units (SI) The Modernized Metric System

2.2 IEC Standards:

~~IEC 60695-2-120 Fire Hazard Testing—Part 2: Testing—Section 20: Glowing/Hot-wire Based Test Methods, Section 20: Hot-Wire Hot-wire Coil Ignitability Test on Materials~~

~~ISO/IEC Guide 52: Glossary of⁴~~

~~IEC 60695-4 Fire Hazard Testing—Part 4: Terminology Concerning Fire Terms and Definitions⁵ Tests⁴~~

2.3 ISO Standards

ISO 13943 Fire Safety—Vocabulary⁵

3. Terminology

3.1 Definitions:

3.1.1 Use Terminology E 176 and ~~ISO/IEC Guide 52~~ ISO 13943 and IEC 60695-4 for definitions of terms used in this test method and associated with fire issues. Where differences exist in definitions, those contained in Terminology E 176 shall be used. Use Terminology D 1711 for definitions of terms used in this test method and associated with electrical insulation materials.

3.2 Definitions of Terms Specific to This Standard:

3.2.1 *ignition, n*—initiation of flaming produced by combustion in the gaseous phase that is accompanied by the emission of light.

4. Significance and Use

~~4.1 Under certain conditions, Summary of operation, or when malfunctions occur, it is possible that Test Method 4.1 In this test method, the electrical equipment including, but not limited to, wires, resistors, or other conductors, become abnormally hot. When this happens, a possible result being tested is ignition of the insulation material.~~

~~4.2 This wrapped in a test method assesses wire and the relative resistance circuit is energized until one of electrical insulating materials to ignition by the effect of hot wire sources.~~

~~4.3 This test method determines following happens: (a) the average time, in seconds, required for material specimens to ignite under test ignites, (b) the conditions of test.~~

² K. N. Mathes, Chapter 4, “Surface Failure Measurements”, *Engineering Dielectrics, Vol. IIB, Electrical Properties of Solid Insulating Materials, Measurement Techniques*, R. Bartnikas, Editor, ASTM STP 926, ASTM, Philadelphia, 1987.

³ For referenced ASTM standards, visit the ASTM website, www.astm.org, or contact ASTM Customer Service at service@astm.org. For Annual Book of ASTM Standards, Vol 10.01, volume information, refer to the standard’s Document Summary page on the ASTM website. ~~Annual Book of ASTM Standards, Vol 04.07.~~

⁴ Available from International Electrotechnical Commission (IEC), 3 Rue de Varembe, Geneva, Switzerland.

⁵ Available from International Electrotechnical Commission (IEC), 3 Rue de Varembe, Case postale 56, CH-1211, Geneva 20, Switzerland.

~~4.4 Subject to limitations in precision and bias, this material under test method can be used to categorize materials. Melts, (c) 120 s of exposure have gone by without ignition or melting.~~

5. Significance and Use

~~5.1 During operation of electrical equipment, including wires, resistors, and other conductors, it is possible for overheating to occur, under certain conditions of operation, or when malfunctions occur. When this happens, a possible result is ignition of the insulation material.~~

~~5.2 This test method assesses the relative resistance of electrical insulating materials to ignition by the effect of hot wire sources.~~

~~5.3 This test method determines the average time, in seconds, required for material specimens to ignite under the specified conditions of test.~~

~~5.4 This method is suitable, subject to the appropriate limitations of an expected precision of $\pm 15\%$, to categorize materials.~~

~~5.5 In this procedure the specimens are subjected to one or more specific sets of laboratory conditions. If different test conditions are substituted or the end-use conditions are changed, it is not always possible by or from this test to predict changes in the fire-test-response characteristics measured. Therefore, the results are valid only for the fire test exposure conditions described in this procedure.~~

6. Apparatus

~~56.1 Heater Wire—The heater wire shall be a No. 24 AWG, Nichrome (Nickel-Chrome) wire, that is iron-free having free, with the following nominal properties: the wire has a wire composition of 20 % chromium-80 % nickel, measures a diameter of 0.05 mm (0.020 in.) in diameter, has in., a nominal cold resistance of 5.28 Ω /m (1.61 Ω /ft), and has a length-to-mass ratio of 580 m/kg (864 ft/lb).~~

~~5.2 Due to normal variations in composition, processing, sizing, and metallurgy between wire lots, it is necessary that~~

~~6.2 Calibrate each spool of test wire be calibrated for energized resistance, in accordance with the method outlined in Annex A1. Such calibration is necessary due to the typical variability of wire lots in composition, processing, sizing, and metallurgy.~~

~~56.3 Supply Circuit—A—The supply circuit, which is a means for electrically energizing the heater wire, shall comply with 6.3.1-6.3.4.~~

~~6.3.1 The supply circuit shall have the following capabilities:~~

~~5.3.1 Sufficient capacity shall be sufficient to maintain a continuous linear 50 to 60 Hz power density of at least 0.31 W/mm (8.0 W/in.) over the length of the heater wire at or near unity power factor. Conditions The power density of the supply circuit at 60 A and 1.5 V should result in power density approximating shall approximate 0.3 W/mm.~~

~~56.3.2 AThe supply circuit shall have a means for adjustment of voltage adjustment to achieve the desired current as determined from Annex A1. Such means for of voltage adjustment shall provide a smooth and continuous adjustment of the power level.~~

~~56.3.3 AThe supply circuit shall have a means of voltage adjustment of measuring the power to within $\pm 2\%$.~~

~~56.3.4 The test circuit shall be provided with an easily actuated on-off switch for the test power, and with timers to record the duration of the application of test power.~~

~~56.4 Test Chamber—A—Use as a test chamber a draft-free closed chamber having a volume of at least 0.3 m³ (10.5 ft³). The ratio between any two transverse dimensions of the chamber shall not exceed 2.5. The test chamber shall be positively vented to the outside of the test facility before and after the test, but it must be shall remain closed and unvented during the test. The chamber shall be equipped with an observation window.~~

~~56.5 Test Fixture—Two supporting posts shall be positioned 70 mm (2³/₄ in.) apart to support the specimen in a horizontal position, at a height of 60 mm (2³/₈ in.) above the bottom of the test chamber, in the approximate center of the test chamber.~~

~~56.6 Specimen-Winding Fixture—A fixture that will shall be provided to uniformly position the wire, with a spacing of 6.35 \pm 0.05 mm (0.250 \pm 0.002 in.) between turns and with a winding tension of 5.4 \pm 0.02 N (1.21 \pm 0.0045 lbf).~~

6. Safety Precautions

~~6.1 It is possible that fumes and products of incomplete combustion are liberated from the specimen when conducting this test. Avoid the inhalation of such fumes and products of combustion and exhaust them from the test chamber after each run.~~

~~6.2 Take precautions to safeguard the health of personnel against the risk of explosion or fire, the inhalation of smoke, or other products of combustion, or the exposure to the residues potentially remaining on the specimen after testing.~~

7. Safety Precautions

~~7.1 It is possible that fumes and products of incomplete combustion are liberated from the specimen when conducting this test. Avoid the inhalation of such fumes and products of combustion and exhaust them from the test chamber after each run.~~

~~7.2 Take precautions to safeguard the health of personnel against the risk of explosion or fire, the inhalation of smoke, or other products of combustion, or the exposure to the residues potentially remaining on the specimen after testing.~~

8. Test Specimens

~~78.1 The test specimen shall consist of a bar measuring 12.5 \pm 0.2 by 125 \pm 5 mm (1/2 by 5 in.) and of the thickness to be tested.~~

89. Conditioning

~~89.1 Condition the specimens and heater wire as follows:~~

89.1.1 Sample Conditioning—Prior to testing, maintain the samples in a dry condition. If this is not practical, dry the samples in an air-circulating oven at $70 \pm 2^\circ\text{C}$ ($158 \pm 3.5^\circ\text{F}$) for seven days and cool over a desiccant, such as silica gel, for a minimum of 4 h. Prior to testing, condition the dry samples for at least 40 h at $23 \pm 2^\circ\text{C}$ ($73 \pm 3.5^\circ\text{F}$) and $50 \pm 5\%$ relative humidity. Maintain the test facilities at $50 \pm 5\%$ relative humidity and 23°C .

89.1.2 Heater Wire Conditioning and Calibration—For each test, use a length of previously calibrated wire measuring approximately 250 mm (10 in.). Prior to testing, anneal each straight length by energizing the wire to dissipate 0.26 W/mm of length (6.5 W/in. of length) for 8 to 12 s to relieve the internal stresses within the wire. Calibrate the wire in accordance with Annex A1 to determine the correct current level.

910. Procedure

910.1 Wrap the center portion of the test specimen with a test wire, conditioned in accordance with 89.1.2, using the winding fixture as specified in 4.6.6 and a winding force of $5.4 \pm 0.02\text{ N}$ ($1.21 \pm 0.0045\text{ lbf}$). Apply five complete turns spaced $6.35 \pm 0.05\text{ mm}$ ($1/4\text{ in.}$) between turns.

910.2 Position the specimen on the test fixture such that the length and width are horizontal. Securely connect the free ends of the wire to the test circuit. The connection is to be capable of transmitting the test power without significant losses, and insofar as possible, not mechanically affect the specimen during the test.

910.3 Start the test by energizing the circuit to dissipate 0.26 W/mm (6.5 W/in.) through the nickel-chrome wire. The 0.26 W/mm shall be maintained during the test.

910.4 Continue heating until the test specimen ignites (see 3.2.1). When ignition occurs, shut off the power and record the time to ignition. Discontinue the test if ignition does not occur within 120 s. For specimens that melt through the wire without ignition, discontinue the test when the specimen is no longer in intimate contact with all five turns of the heater wire.

910.5 Note the following observations:

910.5.1 The time to ignition of each specimen, and

910.5.2 The time for each specimen to melt through the wire if appropriate.

10. Report

10.1 Report the following information:

~~10.1.1 Complete identification of the material tested including type, source, and manufacturer's code number,~~

~~10.1.2 Testing room conditions,~~

~~10.1.3 Number of specimens tested,~~

~~10.1.4 Thickness of specimens tested,~~

~~10.1.5 Time to ignition for each specimen or the time at which the wire turns no longer contact the specimen,~~

~~10.1.6 Calculation and record of the average time for ignition,~~

~~10.1.7 Calibrated test current, and~~

~~10.1.8 Geometry of test chamber.~~

11. PReport

11.1 Report the following information:

~~11.1.1 Complete identification of the material tested including type, source, and Bias~~

~~11.1 It is likely that, when care is taken manufacturer's code number,~~

~~11.1.2 Testing room conditions,~~

~~11.1.3 Number of specimens tested,~~

~~11.1.4 Thickness of specimens tested,~~

~~11.1.5 Time to adhere to this test method; ignition for each specimen or the average determined will fall within $\pm 15\%$ of time at which the value obtained by an interlaboratory evaluation.~~

~~11.2 A statement wire turns no longer contact the specimen,~~

~~11.1.6 Calculation and record of bias the average time for this ignition,~~

~~11.1.7 Calibrated test method is not practicable since there is no standard reference material available with a known characteristic current, and~~

~~11.1.8 Geometry of true resistance to ignition. test chamber.~~

12. Precision and Bias

~~12.1 It is likely that, when care is taken to adhere to this test method, the average determined will fall within $\pm 15\%$ of the value obtained by an interlaboratory evaluation.~~

~~12.2 A statement of bias for this test method is not practicable since there is no standard reference material available with a known characteristic of true resistance to ignition.~~

13. Keywords

~~123.1 hot wire; ignition; resistance to ignition~~

ANNEX

(Mandatory Information)

A1. TEST WIRE CALIBRATION

A1.1 General

A1.1.1 Due to normal variations in metals, it is essential that each spool of test wire be calibrated with respect to energized resistance according to the following procedure. A mathematical relationship is developed between current and power dissipation, based on performance under the calibration experiment. Essentially, the voltage over a carefully measured length of wire, and the current through the wire are measured over a range of values to establish the power-current relationship. It has been found that the variation of electrical resistance of the test wire within the spool is not significant.

A1.2 Apparatus and Equipment

A1.2.1 Position approximately 250 mm (10 in.) of test wire as a horizontal open loop connected to the supply contacts of the hot wire ignition equipment (see Fig. A1.1). Place an ammeter in the circuit. Fit a voltmeter with small voltage-measuring probes for measuring voltage across a measured length of the wire.

A1.3 Procedure

A1.3.1 Position the voltmeter probes near the ends of the test wire prior to connecting the wire, with the wire in a horizontal straight position. Carefully measure and record the length of the wire between the contact points of the clips. Connect the wire to the test apparatus and energize to current levels, from 1 to 8 A in increments of 1 A. Record current and voltage at each level.

A1.4 Calculation

A1.4.1 For each measurement, calculate the linear power density as follows:

$$W = \frac{EI}{L}$$

where:

- W = linear power density, W/mm (or W/in.),
- E = measured voltage, V,
- I = measured current, A, and
- L = measured length between voltage clips, mm (or in.).

A1.4.2 Construct a calibration curve of current as a function of linear power density. The desired calibrated current for the given spool of test wire is then obtained from a calibration curve as that current corresponding to 0.26 W/mm (6.5 W/in.) (see Fig. A1.2.).

A1.4.3 Since the calibration curve must pass through the zero point (current equal 0, power equal 0), and since it is known that the ideal functional relationship is of the form $I = c\sqrt{W}$, then it is possible to mathematically compute the value of c to yield the best least squares approximation to the calibration data by square root regression. Calculate the value of c as follows:

$$c = \frac{1}{r} = \frac{n\epsilon\sqrt{W_i I_i} - \epsilon\sqrt{W_i} \epsilon I}{n\epsilon W_i - \epsilon\sqrt{W_i}^2}$$

where: I_i and W_i are the individual values of the calibration experiment. Calculate the calibration current, I_c , as follows:

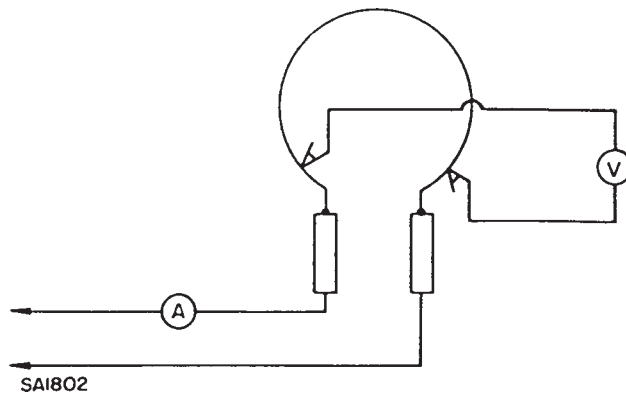

FIG. A1.1 Test Apparatus

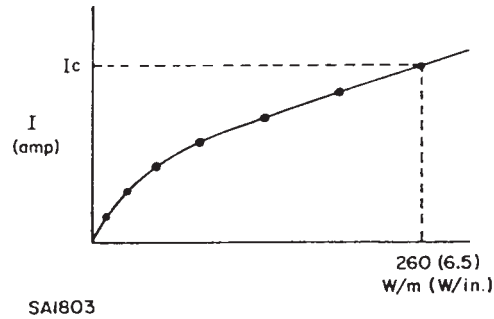

FIG. A1.2 Calibration Curve

$$I_c = c\sqrt{6.5} = 2.55 c$$

ASTM International takes no position respecting the validity of any patent rights asserted in connection with any item mentioned in this standard. Users of this standard are expressly advised that determination of the validity of any such patent rights, and the risk of infringement of such rights, are entirely their own responsibility.

This standard is subject to revision at any time by the responsible technical committee and must be reviewed every five years and if not revised, either reapproved or withdrawn. Your comments are invited either for revision of this standard or for additional standards and should be addressed to ASTM International Headquarters. Your comments will receive careful consideration at a meeting of the responsible technical committee, which you may attend. If you feel that your comments have not received a fair hearing you should make your views known to the ASTM Committee on Standards, at the address shown below.

This standard is copyrighted by ASTM International, 100 Barr Harbor Drive, PO Box C700, West Conshohocken, PA 19428-2959, United States. Individual reprints (single or multiple copies) of this standard may be obtained by contacting ASTM at the above address or at 610-832-9585 (phone), 610-832-9555 (fax), or service@astm.org (e-mail); or through the ASTM website (www.astm.org).