



Designation: F 951 – 01

## Standard Test Method for Determination of Radial Interstitial Oxygen Variation in Silicon Wafers<sup>1</sup>

This standard is issued under the fixed designation F 951; the number immediately following the designation indicates the year of original adoption or, in the case of revision, the year of last revision. A number in parentheses indicates the year of last reapproval. A superscript epsilon ( $\epsilon$ ) indicates an editorial change since the last revision or reapproval.

### 1. Scope

1.1 This test method covers test sight selection and data reduction procedures for radial variation of the interstitial oxygen concentration in silicon slices typically used in the manufacture of microelectronic semiconductor devices.

1.2 This test method is intended as both a referee and production test through selection of an appropriate test position plan.

1.3 The interstitial oxygen content may be measured in accordance with Test Methods F 1188, F 1366 or F 1619, DIN 50438/1, JEITA 61, or any other procedure agreed upon by the parties to the test.

1.4 Acceptable sample surface finishes are specified in the applicable test methods. This test method is suitable for use on chemically etched, single-side polished and double-side polished silicon slices with no surface defects that could adversely change infrared radiation transmission through the slice, provided that appropriate test methods for oxygen content are selected.

1.5 *This standard does not purport to address all of the safety concerns, if any, associated with its use. It is the responsibility of the user of this standard to establish appropriate safety and health practices and determine the applicability of regulatory limitations prior to use.*

### 2. Referenced Documents

#### 2.1 ASTM Standards:

F 533 Test Method for Thickness and Thickness Variation of Silicon Wafers<sup>2</sup>

F 1188 Test Method for Interstitial Atomic Oxygen Content of Silicon by Infrared Absorption<sup>2</sup>

F 1366 Test Method for Measuring Oxygen Concentration in Heavily Doped Silicon Substrates by Secondary Ion Mass Spectrometry<sup>2</sup>

F 1619 Test Method for Measurement of Interstitial Oxygen Content of Silicon Wafers by Infrared Absorption Spec-

troscopy with p-Polarized Radiation Incident at the Brewster Angle<sup>2</sup>

#### 2.2 DIN Standard:

DIN 50438/1 Test of Materials for Semiconductor Technology; Determination of Impurity Content in Silicon by Infrared Absorption; Oxygen<sup>3</sup>

#### 2.3 JEITA Standard:

JEITA 61 Standard Test Method for Interstitial Atomic Oxygen Content of Silicon by Infrared Absorption<sup>4</sup>

#### 2.4 ANSI Standard:

ANSI/ASQC 21.4<sup>5</sup>

### 3. Summary of Test Method

3.1 Instruments are selected and qualified according to the test procedure chosen.

3.2 Measurements are made at the specified test locations and a relative oxygen variation is calculated by one of four available plans.

### 4. Significance and Use

4.1 The presence of oxygen can be beneficial to certain manufacturing operations by preventing the formation of process-induced defects. To the extent that this is true, it becomes important that the oxygen be uniformly distributed over the entire slice.

4.2 Multiple test plans are included to satisfy a variety of requirements. The characteristic shape and magnitude of oxygen concentration distributions in crystals are functions of the crystal growth process. Although the specified test plans are intended to cover oxygen concentration distributions which are typically found, other distributions may occur. In such cases, it may be necessary to use test positions other than those specified in order to adequately describe the distribution pattern.

4.3 This test method may be used for process control,

<sup>3</sup> DIN 50438/1 is the responsibility of DIN Committee NMP 221, with which ASTM F-1 maintains close liaison. DIN 50438/1 is available from Beuth Verlag GmbH, Burggrafenstrasse 4-10, D-1000, Berlin 30, Germany.

<sup>4</sup> JEITA 61 is the responsibility of the JEITA Silicon Wafer Committee, with which ASTM F01 maintains close liaison. JEITA 61 is available from the Japan Electronics and Information Technology Industries Association, Kikai-Shinko-Kaikan, 3-5-8 Shiba koen, Minato-ku, Tokyo 105-0011, Japan.

<sup>5</sup> Available from American Society for Quality Control (ASQC), P.O. Box 3005 Milwaukee, WI 53201-9404.

<sup>1</sup> This test method is under the jurisdiction of ASTM Committee F01 on Electronics and is the direct responsibility of Subcommittee F01.06 on Silicon Materials and Process Control.

Current edition approved Oct. 10, 2001. Published December 2001. Originally published as F 951 – 85. Last previous edition F 951 – 96.

<sup>2</sup> Annual Book of ASTM Standards, Vol 10.05.

research and development, and materials acceptance purposes. In the absence of an interlaboratory evaluation of the precision of this test method, its use for materials acceptance is not recommended unless the parties involved establish the degree of correlation which can be expected (see Section 11).

## 5. Interferences

5.1 Variations of optical thickness can be caused by thickness or surface finish variations, or both.

5.2 Beam size differences from instrument to instrument can cause errors when the beam area is smaller than the aperture used in this test method.

## 6. Apparatus

6.1 *Infrared Spectrophotometer*, as required by the test method for interstitial oxygen measurement.

6.2 *Thickness Measurement Equipment*, as required by the test method.

6.3 *Fixturing*, capable of positioning test slices to the tolerances required in each plan, including a fixed  $7.0 \pm 0.5$ -mm circular aperture centered on the infrared beam.

## 7. Sampling

7.1 Sampling plans must be agreed upon by the participants.

7.2 For acceptance testing, ANSI/ASQC 21.4, normal level, must be used unless other agreements have been made.

## 8. Procedure

8.1 Place test slice in the fixture apparatus and position in accordance with the test plan to be used (See Annexes, Fig. A1.1, Fig. A2.1, Fig. A3.1, and Fig. A4.1).

8.1.1 The spectrophotometer infrared beam is directed through the 7-mm aperture which is located adjacent to the test slice. The test slice is moved, relative to the stationary beam and aperture to the test sites of the appropriate plan.

8.1.2 Slice thickness must be known for each position to  $\pm 0.5$  % of the nominal slice thickness or measured at each position in accordance with Test Method F 533.

8.1.3 For referee situations mark the side of the test slice facing the spectrophotometer infrared source in a noninterfering manner.

8.2 Measure and record oxygen content at each position.

8.2.1 Keep all controllable instrument parameters constant during a test sequence (number of scans, temperature, reference slice, resolution, etc.).

8.3 For referee testing applications, repeat the test plan sequence four additional times.

## 9. Calculations

9.1 Calculate the radial oxygen variation (ROV) for the sample plan selected:

9.1.1 *Plan A—Two Positions* (Fig. A1.1):

$$ROV = \frac{(\text{Edge} - \text{Center})}{\text{Center}} \times 100 \quad (1)$$

9.1.2 *Plan B—Three Positions* (Center and Two Edges, Fig. A2.1):

$$ROV = \frac{(\text{Avg of Edge Values}) - \text{Center}}{\text{Center}} \times 100 \quad (2)$$

9.1.3 *Plan B-1—Five Positions* (Fig. A2.1): ROV is the larger of the values found from the equation in 9.1.2 and the following:

$$ROV = \frac{(\text{Avg of R/2 Values}) - \text{Center}}{\text{Center}} \times 100 \quad (3)$$

9.1.4 *Plan C—Five Positions* (Fig. A3.1):

$$ROV = \frac{(\text{Avg of Edge Values}) - \text{Center}}{\text{Center}} \times 100 \quad (4)$$

9.1.5 *Plan D—Multiple Positions* (Fig. A4.1):

$$ROV = \frac{(\text{Individual High} - \text{Individual Low})}{\text{Center}} \times 100 \quad (5)$$

NOTE 1—All edge positions are located from the center of the IR beam to the slice edge. All other non-center positions are located such that the center of the IR beam is located as given by the dimensions in Fig. A1.1, Fig. A2.1, Fig. A3.1, and Fig. A4.1.

9.2 For referee tests, calculate and include the average ROV, as follows:

$$ROV = (ROV1 + ROV2 + ROV3 + ROV4 + ROV5)/5 \quad (6)$$

## 10. Report

10.1 Report the following information:

10.1.1 Date, operator, and affiliation,

10.1.2 Description of test method used,

10.1.3 Number of slices and their identification,

10.1.4 Sample descriptions including nominal resistivity, thickness, diameter, and surface finishes,

10.1.5 Sample plan used,

10.1.6 Instrument factors,

10.1.6.1 Manufacturer/model,

10.1.6.2 Resolution,

10.1.6.3 Apertured beam size,

10.1.6.4 Differential or air reference method,

10.1.6.5 Measurement wavelength region,

10.1.7 ROV results, and

10.1.8 Any unusual relevant conditions.

## 11. Precision

11.1 The test method precision is directly dependent on the precision of the individual oxygen measurements. If the only sources of precision errors are the individual measurements, the radial oxygen variation precision can be computed for each sampling plan.

## 12. Bias

12.1 No reference standards are available for oxygen variation, so it is impossible to determine bias except for that of the individual measurements. Bias of the individual measurements should be determined in accordance with the procedures of the test methods utilized.

## 13. Keywords

13.1 infrared transmission; interstitial oxygen; oxygen; radial variation; silicon; uniformity; variation

ANNEXES

(Mandatory Information)

A1. PLAN A

A1.1 Position of edge measurement sites are determined by the distance from the sample periphery to the center of the aperture.

A1.2 The edge position shall be  $10.0 \pm 1$  mm from the sample periphery on one of the diameters parallel with or perpendicular to the major flat. The position Annex A1 on the diameter perpendicular to the major flat and at the side of the wafer opposite the major flat is preferred (see Fig. A1.1).

Positions Annex A2 and Annex A3 on the diameter parallel with the major flat may be selected to replace position Annex A1 if agreed to by both customer and supplier. Specify Plan Annex A1, Annex A2, or Annex A3 depending on the position selected.

A1.3 When an interfering minor flat is present, locate the edge position as though the minor flat were not present.

A1.4 Center position shall be within 3 mm of the intersection of any two diameters which are at least  $45^\circ$  apart.

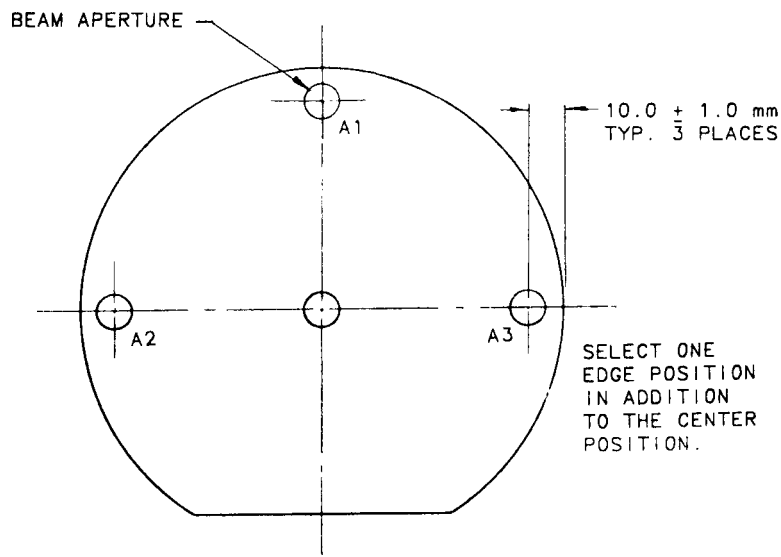

FIG. A1.1 PLAN A

A2. PLAN B

A2.1 All positions are on the diameter parallel to the major flat (see Fig. A2.1).

A2.2 Edge positions shall be  $10.0 \pm 1$  mm from the sample periphery. The center position is the same as Plan A, A1.4.

A2.3 Two additional measurements are made at the half radius [ $(R/2) \pm 1$  mm] positions. These two measurements are

optional, but if made must be in addition to measurements at the center and two edge positions. Customer and supplier must agree on the use of measurements at  $R/2$  positions. Specify Plan B-1 when using all five positions.

A2.4 When an interfering minor flat is present, locate the edge position as though the minor flat were not present.

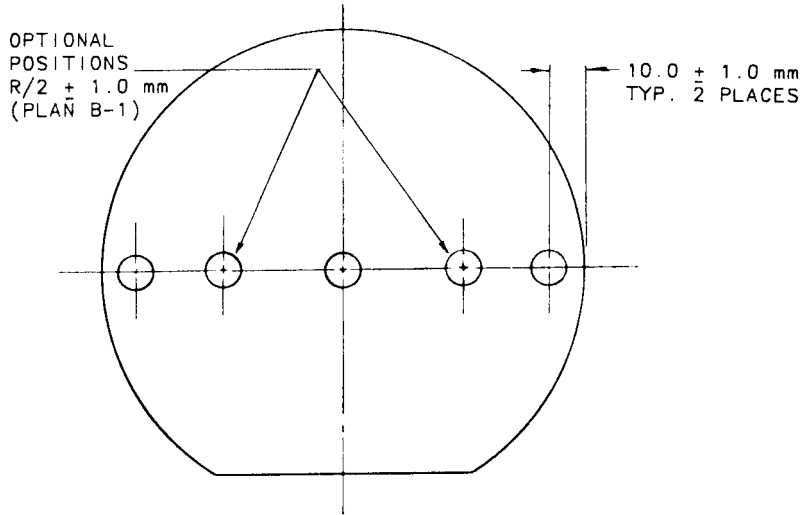

FIG. A2.1 PLAN B

A3. PLAN C

A3.1 All four edge positions coincide with Test Method F 81, Plan B.

A3.2 Edge position tolerances are  $\pm 1$  mm; center position shall be within 3 mm of the intersection of any two diameters which are at least  $45^\circ$  apart (see Fig. A3.1).

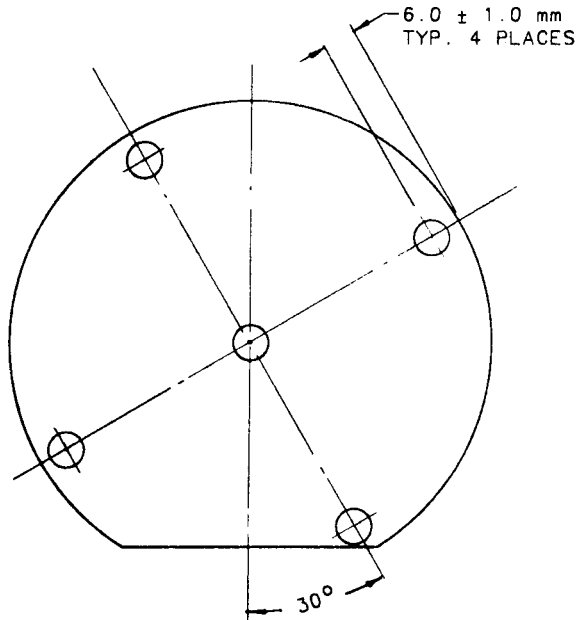

FIG. A3.1 Plan C

A4. PLAN D

A4.1 All measurement positions are on the radius parallel to the major flat (see Fig. A4.1).

A4.2 The first position, nearest sample periphery, shall be located in the same manner as A1.1 and A1.2 of Plan A.

A4.3 Position spacing shall be in 1-cm steps, center to

center, continuing to within 0.5 cm of the sample center.

A4.4 Position numbering begins at the edge (1) and is sequenced toward the center position.

A4.5 If a minor flat is located near Position 1, begin sequencing at the opposite edge.

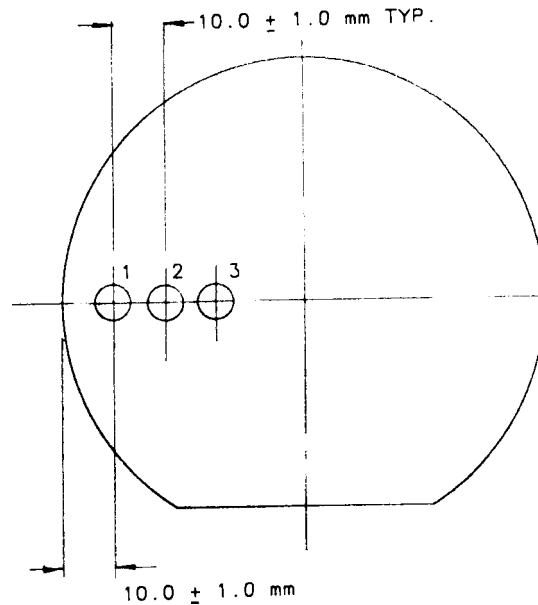

FIG. A4.1 Plan D

ASTM International takes no position respecting the validity of any patent rights asserted in connection with any item mentioned in this standard. Users of this standard are expressly advised that determination of the validity of any such patent rights, and the risk of infringement of such rights, are entirely their own responsibility.

This standard is subject to revision at any time by the responsible technical committee and must be reviewed every five years and if not revised, either reapproved or withdrawn. Your comments are invited either for revision of this standard or for additional standards and should be addressed to ASTM International Headquarters. Your comments will receive careful consideration at a meeting of the responsible technical committee, which you may attend. If you feel that your comments have not received a fair hearing you should make your views known to the ASTM Committee on Standards, at the address shown below.

This standard is copyrighted by ASTM International, 100 Barr Harbor Drive, PO Box C700, West Conshohocken, PA 19428-2959, United States. Individual reprints (single or multiple copies) of this standard may be obtained by contacting ASTM at the above address or at 610-832-9585 (phone), 610-832-9555 (fax), or service@astm.org (e-mail); or through the ASTM website (www.astm.org).