



Designation: D 5743 – 97

Standard Practice for Sampling Single or Multilayered Liquids, With or Without Solids, in Drums or Similar Containers¹

This standard is issued under the fixed designation D 5743; the number immediately following the designation indicates the year of original adoption or, in the case of revision, the year of last revision. A number in parentheses indicates the year of last reapproval. A superscript epsilon (ϵ) indicates an editorial change since the last revision or reapproval.

1. Scope

1.1 This practice covers typical equipment and methods for collecting samples of single or multilayered liquids, with or without solids, in drums or similar containers. These methods are adapted specifically for sampling drums having a volume of 110 gal (416 L) or less. These methods are applicable to hazardous material, product, or waste. Specific sample collection and handling requirements should be described in the site-specific work plan.

1.2 The values stated in inch-pound units are to be regarded as the standard. The values given in parentheses are for information only.

1.3 *This standard does not purport to address all of the safety concerns, if any, associated with its use. It is the responsibility of the user of this standard to establish appropriate safety and health practices and determine the applicability of regulatory limitations prior to use.* Specific precautionary statements are given in 7.2.7.1 and Notes 1 and 2.

2. Referenced Documents

2.1 ASTM Standards:

- D 4687 Guide for General Planning of Waste Sampling²
- D 5088 Practice for the Decontamination of Field Equipment Used at Non-Radioactive Waste Sites³
- D 5283 Practice for Generation of Environmental Data Related to Waste Management Activities: Quality Assurance and Quality Control Planning and Implementation²
- D 5495 Practice for Sampling with a Composite Liquid Waste Sampler (COLIWASA)²

2.2 Other Documents:

Drum Handling Practices at Hazardous Waste Sites, EPA/600/2-86/013, PB 165362, January 1986⁴

Accident Prevention Manual for Industrial Operations, 1992⁵

Occupational Safety and Health Guidance Manual for Hazardous Waste Site Activities, No. 85-115, October 1985⁴

3. Terminology

3.1 Definitions:

3.1.1 *bonding*—touching the sampling equipment to the drum to form an electrically conductive path to minimize potential electrical differences between the sampling equipment and drum, reducing the buildup of static electricity.

3.1.2 *bung*—usually a 2-in. (5.1-cm) or 3/4-in. (1.3-cm) diameter threaded plug designed specifically to close a bung hole.

3.1.3 *bung hole*—an opening in a barrel or drum through which it can be filled, emptied, or vented.

3.1.4 *deheading*—removal of the lid of a closed-head drum; it is usually accomplished with a drum deheader.

3.1.5 *drum*—implicitly any drum, barrel, or non-bulk container of 5 to 110-gal (19 to 416-L) capacity.

3.1.6 *pail*—a small container, usually of 5-gal (19-L) capacity. Pails typically have bungs or spouts, or the entire lid can be removed.

3.1.7 *paperwork*—all required site documentation, which may include the manifests, waste profiles, material safety data sheets (MSDS), site forms, sample labels, seals, and chain of custody forms.

3.1.8 *sludge*—any mixture of solids that settles out of solution. Sludges contain liquids that are not apparent as free liquids.

3.1.9 *work plan*—a plan specific to a particular site; it is for conducting activities specified in the plan.

4. Summary of Practice

4.1 The drum and its contents are inspected, and appropriate sampling equipment is selected. A clean sampling device is lowered slowly into the liquid to be sampled. After the material has entered the device, it is removed from the drum. The contents of the device are discharged into a sample container.

¹ This practice is under the jurisdiction of ASTM Committee D34 on Waste Management and is the direct responsibility of Subcommittee D34.01.02 on Sampling Techniques.

Current edition approved Oct. 10, 1997. Published March 1998. Originally published as D 5743 – 95. Last previous edition D 5743 – 95.

² *Annual Book of ASTM Standards*, Vol 11.04.

³ *Annual Book of ASTM Standards*, Vol 04.09.

⁴ Available from National Technical Information Service, 5285 Port Royal Road, Springfield, VA 22161.

⁵ Available from National Safety Council, P.O. Box 558, Hasca, IL 60143-0558.



The sampling device is then either disposed of or cleaned and decontaminated.

5. Significance and Use

5.1 This practice is intended for use in collecting samples of single and multilayered liquids, with or without solids, from drums or similar containers, including those that are unstable, ruptured, or otherwise compromised. Special handling procedures (for example, remote drum opening, overpressurized drum opening, drum deheading, etc.) are described in *Drum Handling Practices at Hazardous Waste Sites*.

6. Interferences

6.1 The condition of the materials to be sampled, and the condition and accessibility of the drums, will have a significant impact on the selection of sampling equipment.

7. Pre-Sampling

7.1 General Principles and Precautions:

7.1.1 Samples should be collected in accordance with an appropriate work plan (Practice D 5283 and Guide D 4687). This plan must include a worker health and safety section because there are potential hazards associated with opening drums as well as potentially hazardous contents. See the *Occupational Safety and Health Guidance Manual for Hazardous Waste Site Activities* for information on health and safety at hazardous waste sites.

7.1.2 Correct sampling procedures must be applied to conditions as they are encountered. It is impossible to specify rigid rules describing the precise manner of sample collection because of unknowns associated with each liquid sampling situation. It is essential that the samples be collected by a trained and experienced sampler because of the various conditions under which drummed liquids must be sampled.

7.1.3 To be able to make probability or confidence statements concerning the properties of a sampled lot, the sampling procedure must allow for some element of randomness in selection because of possible variations in the material. The sampler should always be on the alert for possible biases arising from the use of a particular sampling device or from unexpected segregation within the material.

7.1.4 The sampling equipment, sample preparation equipment, sample containers, etc. must be clean, dry, and inert to the material being sampled. All equipment, including sample containers, must be inspected before use to ensure that they are clear of obvious dirt and contamination and are in good working condition. Visible contamination must be removed, and the equipment must be decontaminated with the appropriate rinse materials. Decontaminated sampling equipment should be protected from contamination. This may include, but not be limited to, storage in aluminum foil, plastic bags, polytetrafluoroethylene (PTFE) film, or other means of protection that will not impact the sample quality or intended analysis.

7.2 Basic Pre-Sampling Practices:

7.2.1 Review all paperwork.

7.2.2 Select the sampling equipment and sample containers appropriate for the material in the drum, as detailed in the work plan.

7.2.3 Enter the work zone.

7.2.4 Inspect all drums to be sampled visually. Note any abnormal conditions (for example, rust marks, stains, bulges, or other signs of pressurization or leaks) that may require special handling. The work plan should clearly define the limiting conditions under which special handling procedures shall be initiated. See *Drum Handling Practices at Hazardous Waste Sites* for information on opening overpressurized drums and the use of remotely operated drum opening equipment.

7.2.5 Stage the drums to be sampled in a designated work area if they cannot be sampled in their current location. See *Drum Handling Practices at Hazardous Waste Sites* for further information on staging drums.

7.2.5.1 Move the drums to upright stable positions if necessary. Sufficient space shall be left between drums to prevent movement hazards.

7.2.5.2 Allow adequate time for the drum contents to stabilize if movement of a drum is required. The settling time is dependent on the type of material expected.

7.2.5.3 Number or identify uniquely all drums to be sampled.

7.2.6 Perform a detailed inspection of individual drums.

7.2.6.1 Record all relevant information from drum labels, markings, data sheets, and so forth, in the field log book or on forms specified in the work plan.

7.2.6.2 Verify that there are no discrepancies with existing paperwork.

7.2.6.3 Any discovered inconsistency from the paperwork (such as evidence of crystals on the drum exterior) should be noted in the field log book.

7.2.7 Slowly remove the bung or loosen the ring that secures the lid, allowing any pressure or vacuum to equalize.

7.2.7.1 Precautionary Notes:

(1) If the drum or pail appears to be under positive or negative pressure (that is, a slight bulge or dimple in the lid), control the release of pressure until it has equalized. For example, if the drum or pail is equipped with bungs, loosen the smaller bung first since doing so will make it easier to control the release of pressure.

(2) Pails equipped with snap-on lids may be difficult to open. Care must be exercised when opening to minimize the potential of splashing of the contents.

(3) If the top of the drum is dished inward (dimpled), it may “pop” when equalizing pressure, spraying the sampler with any material that is sitting on top of the drum.

(4) If there is evidence of a chemical reaction or sudden pressure buildup, the sampler should leave the area immediately and evaluate whether remote drum opening equipment should be used.

(5) For flammable or explosive materials, the drum and sampling equipment should be grounded if the generation of static electricity while opening or sampling the drum is a possibility. The drum and sampling equipment should be grounded to a ground stake or to an existing ground (building ground, grounded water pipes, etc.). New glass, plastic thieves, or composite liquid waste samplers (COLIWASAs) may have some residual static electrical charge due to the materials in which they are packed and shipped. The work plan should

specify whether grounding is required. See the *Accident Prevention Manual for Industrial Operations* for information on grounding and bonding.

7.2.7.2 Drums should be opened, sampled, and closed individually to minimize the risk of volatilization and exposure.

7.2.7.3 *Drums (or Pails) with Bungs*—When using a manual bung wrench, cover it with a wipe or cloth to control potential liquid spray. Use non-sparking tools.

7.2.7.4 *Drums with Removable Lids*—Loosen the ring slowly with a manual wrench or air impact wrench. Use non-sparking tools.

7.2.7.5 *Pails with Removable Lids (Side-Lever Lock Ring)*—Release the lever slowly.

7.2.7.6 *Pails with Removable Lids (Snap-On)*—Pry the lid loose slowly with a pail lid opener.

7.2.8 Manual or remote puncturing or deheading will be required if the drum has a stuck bung or the lid cannot be removed. See *Drum Handling Practices at Hazardous Waste Sites* for further information on manual or remote drum opening.

7.2.9 If required, insert a measuring rod (graduated in litres or gallons) into the drum to measure the liquid volume and determine the presence of solids at the bottom and estimate their percentage. (If minimal disturbance of the contents is required, the measuring rod can be inserted in the vent bung hole when working with a bung-top-drum.) The rod can be graduated in litres or gallons for a specific size drum, or it can be graduated in linear units (inches, centimetres, and so forth), with the liquid depth converted to volume using an appropriate volume conversion. The measuring rod should be nonreactive to the waste being contacted.

NOTE 1—Caution: Before inserting the measuring rod into the drum, touch the rim gently with the rod (bonding) opposite from the bung to equalize any static charge that the drum may exhibit. The work plan should specify whether bonding is required.

7.2.9.1 For many liquids, the sampling equipment can serve as a substitute measuring device. This can be accomplished by measuring the length of the liquid column as it is being held over the drum and applying an appropriate volume conversion (for example, 1 in. (2.54 cm) equals 1.7 gal (6.43 L) in a 55-gal (208-L) drum).

NOTE 2—Caution: The sampling equipment or measuring rod should be at or near the temperature of the drummed liquid to minimize any reaction caused by temperature differences.

7.3 *Sampling Equipment, Selection*— Table 1 summarizes

TABLE 1 Selection Criteria for Equipment

Equipment	ASTM Standard	One Liquid Layer	Two or More Liquid Layers	Liquid and Solid (Sludge) Layers
Drum thief		X ^A	X	X
COLIWASA	D 5495	X	X	N ^B
Syringe-type sampler		N	N	X
Coring-type sludge sampler		— ^C	—	X
Piston-Type Sampler		X	X	N

^A X = equipment may usually be used in or with this type of waste.

^B N = not the equipment of choice, but it may be used.

^C — = equipment is probably unsuitable.

selection criteria for equipment by the material to be sampled.

7.4 *Sampling Equipment, Materials of Construction*—Each of the sampling devices listed should be constructed from materials that are inert to any materials that may be encountered at a specific site. These devices are usually made of glass, stainless steel, aluminum, brass, or plastic. Devices with permanent coatings or liners of an inert nonreactive material, such as PTFE, may be substituted, if approved by the work plan.

7.5 *Generic Equipment List:*

7.5.1 A list of equipment generally required for sampling liquids follows:

7.5.1.1 Sample containers, lids, and liners;

7.5.1.2 Sample labels;

7.5.1.3 COLIWASAs, drum thieves, sludge samplers, or equivalent devices;

7.5.1.4 Measuring rods;

7.5.1.5 Chain of custody forms;

7.5.1.6 Field log books;

7.5.1.7 Sample cooler;

7.5.1.8 Wipes or cloths, or both;

7.5.1.9 Ice or gel ice;

7.5.1.10 Grounding cables with alligator clips and emery cloth; and

7.5.1.11 Portable monitoring equipment (combustible gas indicator, organic vapor detectors, radiation survey meter, etc.).

7.5.2 Equipment needed to open drums should be non-sparking (brass or beryllium copper) and include, but not be limited to, the following:

7.5.2.1 Bung wrenches (one straight and one bent),

7.5.2.2 Flathead screwdriver,

7.5.2.3 Breaker bar (½ in. (13 mm)),

7.5.2.4 Ratchet (½ in. (13 mm)),

7.5.2.5 Speed handle (½ in. (13 mm)),

7.5.2.6 Adjustable wrenches (10 and 12 in. (25 and 30 cm)),

7.5.2.7 Air impact wrench and sockets, and

7.5.2.8 Pail lid opener.

8. Sample Collection

8.1 *Basic Sampling Practice:*

8.1.1 Bond the sampling equipment to the drum, if specified in the work plan.

8.1.2 Collect a sample from the drum. Whenever possible, do not sample where the measuring rod has been inserted; however, bung-type drums might not permit avoidance of the disturbed region.

8.1.3 Note the physical characteristics, including any discrepancies (such as solidified contents or crystalline material).

8.1.4 Place the collected material in a sample container.

8.1.5 Close the sample container.

8.1.6 Wipe the outside of the sample container. Dispose of the wipe cloth properly.

8.1.7 Record in the field log book all of the relevant conditions and physical characteristics associated with the sample.

8.1.8 Fill out all of the required paperwork for each sample, as required by the work plan.

8.1.9 Complete and attach a label to the side of the sample container before or after sampling, as directed by the work

plan. The sample label should include the following:

- (1) Sample ID number,
- (2) Name of sampler,
- (3) Sampler's initials or signature,
- (4) Date and time of sampling, and
- (5) Sample location.

The sample label can also include the following:

- (1) Sampling information (for example, grab or composite),
- (2) Preservative or preservation required,
- (3) Special instructions, and
- (4) Analysis request.

8.2 Sampling with a Drum Thief:

8.2.1 *General Description*—A tube of small diameter, which yields a vertical representation of the contents of a drum when lowered and sealed (see Fig. 1).

NOTE 3—When sampling liquids of high specific gravity, it may be difficult to retain the entire sample in the drum thief. A smaller-diameter drum thief may overcome this problem. The use of a COLIWASA or similar device may be necessary if the problem persists.

8.2.2 *Operation and Use*—Slowly insert the tube vertically until it reaches either the bottom of the drum or the liquid layer to be sampled. The sampling device should be lowered at a rate that permits the liquid level inside and outside the tube to be approximately the same.

NOTE 4—Multiple sample increments are usually necessary to provide enough sample volume for analysis and quality control (QC). Drum contents will become increasingly disturbed with each successive insertion of the drum thief.

8.2.2.1 Cover the top of the tube with the thumb or a rubber stopper to form a seal. Use gloves or a stopper, as described in the work plan.

8.2.2.2 Withdraw the tube carefully.

8.2.2.3 Use a clean cloth or paper towel to wipe the tube as it is being extracted from the liquid, to prevent unnecessary dripping.

8.2.2.4 Note the proportions of any layers or solids.

8.2.2.5 Place the bottom end of the tube into the sample container, and release the contents slowly.

8.3 Sampling with a COLIWASA:

8.3.1 *General Description*—A glass, plastic, or metal tube with an end closure that can be opened while the tube is

immersed in the waste to be sampled (see Practice D 5495). The COLIWASA will yield a vertical representation of a drum's contents when immersed in the open position into a drum (see Fig. 2).

NOTE 5—Multiple sample increments are usually necessary to provide enough sample volume for analysis and QC. Drum contents will become increasingly disturbed with each successive insertion of the COLIWASA.

8.4 Sampling with a Syringe-Type Sampler:

8.4.1 *General Description*—A tube with a manually operated piston that can be used as a syringe for high-viscosity liquids or as a coring device for sludge (see Fig. 3).

8.4.2 *Operation and Use*—(1) For high-viscosity liquids, the tube is lowered to the sampling point and the piston is pulled out to collect the sample. (2) For sludge, the tube is lowered to the surface of the sludge. The sampler body is pushed into the sludge while allowing the piston to move up within the sampler body.

8.4.2.1 Assemble with the piston at the lower end of the sampler body. Attach the bottom valve (for high-viscosity liquids) or the coring tip (for sludge).

(1) For high-viscosity liquids, lower to the sampling point and withdraw the piston to collect the sample. Close the bottom valve by pushing against the side or bottom of the container with the sampler body.

(2) For sludge, lower to the surface of the material to be sampled. Push the sampler body into the material while allowing the piston to move up within the sampler body.

8.4.2.2 Use a clean cloth or paper towel to wipe the sampler body as it is being extracted from the liquid or sludge, to prevent unnecessary dripping.

8.4.2.3 Transfer the sample into the sample container by opening the bottom valve, if fitted, and pushing the piston down.

8.5 Sampling with a Coring-Type Sampler:

8.5.1 *General Description*—A coring-type sampler consists of a cylinder, a coring tip (or auger tip) with a retaining device,

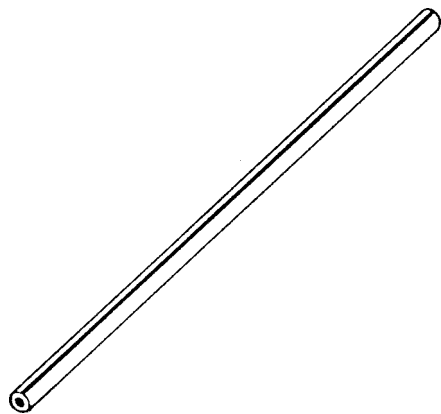

FIG. 1 Drum Thief

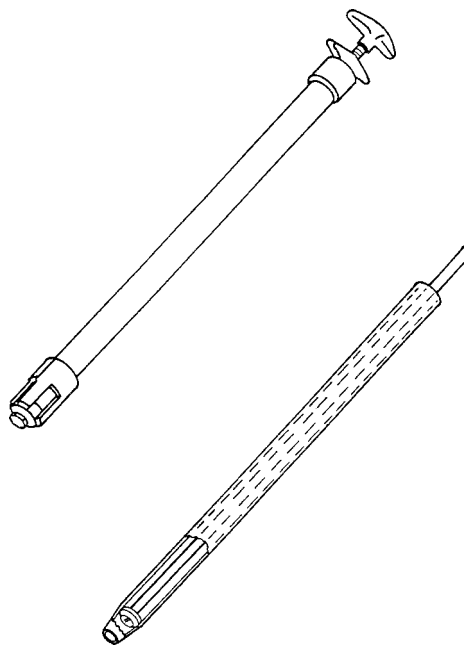

FIG. 2 COLIWASAs (Typical)

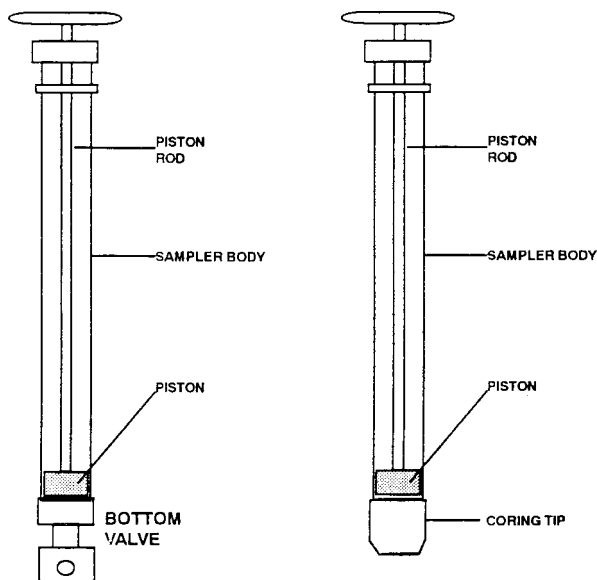

FIG. 3 Syringe-Type Sampler (Typical)

a top cap, and an extension with a cross handle (see Fig. 4). A thin-walled internal sleeve may be used to contain the sample.

8.5.2 Operation and Use—The coring-type sampler is pushed (pushed and rotated with an auger tip) into the sludge to collect the sample and removed. The retaining device allows the sludge to enter the cylinder when pushing the sampler. The retaining device closes to hold the sludge in the cylinder while removing the sampler.

8.5.3 Remove the top cap and transfer the sample from the cylinder into a sample container. If equipped with an internal sleeve, remove the top cap and place an end cap on the internal sleeve. Invert, remove the internal sleeve from the cylinder, and place an end cap on the open end of the sleeve.

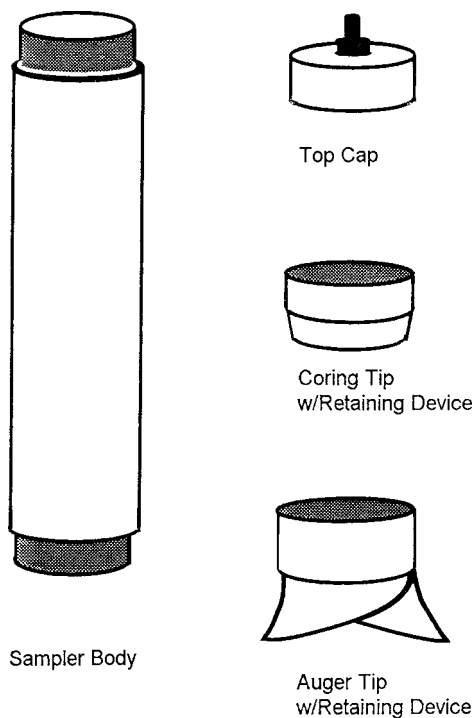

FIG. 4 Corer-Type Sampler (Typical)

8.6 Sampling with a Plunger-Type Sampler:

8.6.1 General Description—A liquid sampling device that consists of a sample tube, sample line or rod, headsection, and plunger (see Fig. 5). The sample jar is connected to the headsection and the sample tube is lowered into the material to be sampled. After insertion the plunger is engaged into the sample tube lifting the sampled materials directly into a sample jar.

8.6.2 Operation and Use—Slowly insert the sampler vertically into the material to be sampled. Lower the sampler at a controlled rate to allow for representative sample collection. When the sampler reaches the bottom, or desired depth, the plunger mechanism is engaged. This secures the sample within the sample tube.

8.6.3 Without removing the sampler from the container and with the plunger lodged inside the sample tube, apply a constant and continual upward force on the sample line or rod. Retract the plunger at a rate that allows for a controlled delivery of the material into the sample jar. Continue to retract the plunger until the unit is seated into the headsection. Prior to removing the sample jar from the headsection, allow sufficient time for residual materials to drain.

9. Post-Sampling

9.1 Remove all sampling equipment from the work zone.

9.2 Transfer all reusable sampling equipment that was in contact with the waste to a predesignated decontamination area. Decontaminate the equipment according to the protocol established in the work plan (Practice D 5088). Decontaminated sampling equipment should be protected from contamination. This may include, but not be limited to, storage in aluminum foil, plastic bags, PTFE film, or other means of protection that will not impact the sample quality or intended analysis.

9.3 Dispose properly of all used (disposable) contacting equipment.

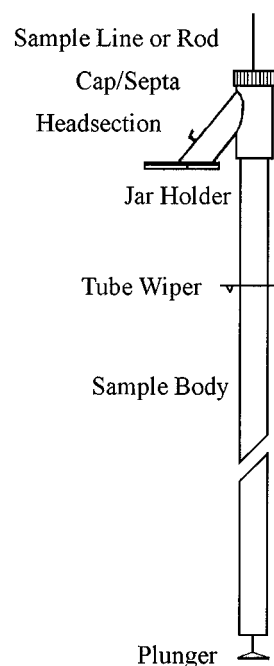

FIG. 5 Plunger-Type Sampler (Typical)



10. Data Quality Objectives

10.1 The objectives for sampling and testing of liquids and sludges should be specified in the work plan.

11. Quality Control

11.1 Quality Control (QC) samples (for example, equipment blanks, trip blanks, and duplicates) must be collected as

required by the work plan. These QC samples must be evaluated to provide a determination of the quality of the sampling and reliability of the resulting analytical data.

12. Keywords

12.1 COLIWASA; drum; drum thief; liquid; pail; sampling; sludge sampler; waste

ASTM International takes no position respecting the validity of any patent rights asserted in connection with any item mentioned in this standard. Users of this standard are expressly advised that determination of the validity of any such patent rights, and the risk of infringement of such rights, are entirely their own responsibility.

This standard is subject to revision at any time by the responsible technical committee and must be reviewed every five years and if not revised, either reapproved or withdrawn. Your comments are invited either for revision of this standard or for additional standards and should be addressed to ASTM International Headquarters. Your comments will receive careful consideration at a meeting of the responsible technical committee, which you may attend. If you feel that your comments have not received a fair hearing you should make your views known to the ASTM Committee on Standards, at the address shown below.

This standard is copyrighted by ASTM International, 100 Barr Harbor Drive, PO Box C700, West Conshohocken, PA 19428-2959, United States. Individual reprints (single or multiple copies) of this standard may be obtained by contacting ASTM at the above address or at 610-832-9585 (phone), 610-832-9555 (fax), or service@astm.org (e-mail); or through the ASTM website (www.astm.org).