



Designation: D 6418 – 03<sup>4</sup>

## Standard Practice for Using the Disposable En Core Sampler for Sampling and Storing Soil for Volatile Organic Analysis<sup>1</sup>

This standard is issued under the fixed designation D 6418; the number immediately following the designation indicates the year of original adoption or, in the case of revision, the year of last revision. A number in parentheses indicates the year of last reapproval. A superscript epsilon (ε) indicates an editorial change since the last revision or reapproval.

### 1. Scope

1.1 This practice is intended for application to soils that may contain volatile waste constituents.

---

<sup>1</sup> This practice is under the jurisdiction of ASTM Committee D34 on Waste Management and is the direct responsibility of Subcommittee D34.01.03 on Sampling Equipment.

Current edition approved ~~March 10, 2003~~; Feb. 1, 2004. Published ~~May 2003~~; April 2004. Originally approved in 1999 as D 6418 – 99. Last previous edition approved in 200~~4~~<sup>3</sup> as D 6418 – 0~~3~~<sup>4</sup>.

1.2 This practice provides a procedure for using the disposable En Core<sup>2</sup> sampler to collect and store a soil sample for volatile organic analysis.

1.3 It is recommended that this standard be used in conjunction with ~~Practice~~ Guide D 4547 and Guide D 4687.

1.4 *This standard does not purport to address all of the safety concerns, if any, associated with its use. It is the responsibility of the user of this standard to establish appropriate safety and health practices and determine the applicability of regulatory limitations prior to use.*

NOTE 1—ASTM takes no position respecting the validity of any patent rights asserted in connection with any item mentioned in this standard. Users of this standard are expressly advised that determination of the validity of any such patent rights, and the risk of infringement of such rights, are entirely their own responsibility.

## 2. Referenced Documents

### 2.1 ASTM Standards:<sup>3</sup>

D 2777 Practice for Determination of Precision and Bias of Applicable Methods of Committee D-19 on Water

~~D 4547 Practice~~ 4547 Guide for Sampling Waste and Soils for Volatile Organics

D 4687 Guide for General Planning of Waste Sampling

D 5792 Practice for Generation of Environmental Data Related to Waste Management Activities: Development of Data Quality Objectives

## 3. Summary of Practice

3.1 This practice provides a procedure for using the disposable En Core sampler to collect and store a soil sample of approximately 5 or 25 g for volatile organic analysis. The En Core sampler, which consists of a coring body/storage chamber, O-ring sealed plunger, and O-ring sealed cap, is designed to collect and hold a soil sample during shipment to the laboratory for analysis.

3.2 After the sample is collected in the En Core sampler, the coring body/storage chamber is sealed with a slide-on cap and immediately becomes a sample storage chamber. To minimize loss of volatile compounds due to volatilization, or biodegradation, or both, from the time of collection until analysis or chemical preservation in the laboratory (see ~~Practice~~ Guide D 4547), sample storage options are specified at  $4 \pm 2^\circ\text{C}$  for up to 48 h; at  $-12 \pm 2^\circ\text{C}$   $-7$  to  $-21^\circ\text{C}$  for up to 14 days; or at  $4 \pm 2^\circ\text{C}$  for up to 48 h followed by storage at  $-12 \pm 2^\circ\text{C}$   $-7$  to  $-21^\circ\text{C}$  for up to five days (see Appendix X1 and reports referenced in footnotes 4, 5, and 6 for information on the performance of the En Core sampler under these storage conditions).<sup>4,5,6</sup> Storage of samples in the En Core sampler at  $4 \pm 2^\circ\text{C}$  or  $-12 \pm 2^\circ\text{C}$   $-7$  to  $-21^\circ\text{C}$  for longer holding times than those listed above is an option, provided it can be shown that the longer storage time used does not influence the concentrations of the volatile organic compounds (VOCs) of interest in the samples, or that the data generated by analysis of the samples meet the data quality objectives (DQOs); (see Practice D 5792). This practice does not use methanol preservation or other chemical preservatives in the field.

## 4. Significance and Use

4.1 This practice is for use in collecting and storing 5- or 25-g soil samples for volatile organic analysis in a manner that minimizes loss of contaminants due to volatilization, or biodegradation, or both. The En Core sampler serves as both the sampling device and sample storage chamber.

4.2 In performing the practice, the integrity of the soil sample structure is maintained during sample collection, storage, and transfer in the laboratory for analysis or preservation.

4.3 During sample collection, storage, and transfer, there is very limited exposure of the sample to the atmosphere.

4.4 Laboratory subsampling is not required when performing this practice. The sample is expelled directly from the coring body/storage chamber into the appropriate container for analysis or preservation without disrupting the integrity of the sample. Subsampling from the En Core device should not be performed to obtain smaller sample sizes for analysis.

4.5 This practice specifies sample storage in the En Core sampler at  $4 \pm 2^\circ\text{C}$  for up to 48 h; at  $-12 \pm 2^\circ\text{C}$   $-7$  to  $-21^\circ\text{C}$  for up to 14 days; or at  $4 \pm 2^\circ\text{C}$  for up to 48 h followed by storage at  $-12 \pm 2^\circ\text{C}$   $-7$  to  $-21^\circ\text{C}$  for up to five days (see Appendix X1 and reports referenced in footnotes 4, 5, and 6 for information on the performance of the En Core sampler under these storage

<sup>2</sup> En Core is a registered trademark of En Novative Technologies, Inc., Green Bay, WI. The En Core sampler is covered by a patent. Interested parties are invited to submit information regarding the identification of an alternative(s) to this patented item to the ASTM Headquarters. Your comments will receive careful consideration at a meeting of the responsible technical committee, which you may attend.

<sup>3</sup> For referenced ASTM standards, visit the ASTM website, [www.astm.org](http://www.astm.org), or contact ASTM Customer Service at [service@astm.org](mailto:service@astm.org). For *Annual Book of ASTM Standards*, Vol 11.01, volume information, refer to the standard's Document Summary page on the ASTM website.

*Annual Book*

<sup>4</sup> Hewitt, A. D., Frozen Storage of ASTM Soil Samples for Volatile Organic Compound Analysis, *Environmental Testing and Analysis*, Vol 11.04, 8, No. 5, 1999, pp. 18–25.

<sup>5</sup> Hewitt, A. D., Frozen Storage

<sup>5</sup> A copy of Soil Samples for Volatile Organic Compound Analysis, *Environmental Testing and Analysis*, Vol 8, No. 5, 1999, pp. 18–25; the research report describing the study performed to evaluate the precision of the En Core sampler to store low VOC concentrations is available from ASTM Headquarters. Request RR: D34–1014.

<sup>6</sup> A copy of the research report describing the study performed to evaluate the precision performance of the En Core sampler to store low VOC concentrations at  $-7 \pm 1^\circ\text{C}$  and  $-21 \pm 2^\circ\text{C}$  is available from ASTM Headquarters. Request RR: D34–10145.

conditions).<sup>4,5,6</sup> Storage of samples in the En Core sampler at  $4 \pm 2^\circ\text{C}$  or  $-12 \pm 2^\circ\text{C}$   $-7$  to  $-21^\circ\text{C}$  for longer holding times than those listed above is an option, provided it can be shown that the longer storage time used does not influence the concentrations of the VOCs of interest in the samples, or that the data generated by analysis of the samples meet the DQOs (see Practice D 5792).

4.6 This practice does not use methanol preservation or other chemical preservatives in the field. As a result, there are no problems associated with flammability hazards, shipping restrictions, or dilution of samples containing low volatile concentrations due to solvents being added to samples in the field.

4.7 The En Core sampler is a single-use device. It should not be cleaned, or reused, or both.

4.8 This practice cannot be used for sampling cemented material, consolidated material, or material having fragments coarse enough to interfere with proper coring techniques.

## 5. Apparatus

5.1 *En Core Sampler*— The En Core sampler has three components: the coring body/storage chamber, which is volumetrically designed to collect and store a soil sample of approximately 5 or 25 g; an O-ring sealed plunger for nondisruptive extrusion of the sample into an appropriate container for analysis or preservation; and, a slide-on cap having an O-ring seal and locking arm mechanism (see Fig. 1). The coring body/storage chamber of the 5-g sampler has a volume of  $3\text{ cm}^3$  to give a sample size of approximately 5 g, assuming a soil density of  $1.7\text{ g/cm}^3$ . The coring body/storage chamber of the 25-g sampler has a volume of  $14.5\text{ cm}^3$  to give a sample size of approximately 25 g, assuming a soil density of  $1.7\text{ g/cm}^3$ . The seals of the sampler are provided by three polytetrafluoroethylene-coated fluoroelastomer O-rings (see Fig. 1). The coring body/storage chamber, plunger, and cap of the En Core sampler are constructed of an inert composite polymer. The En Core sampler is certified as clean and should not be reused. There are two stainless steel reusable attachments that are used with the En Core sampler. These are a T-handle, which is used to push the sampler into the soil for sample collection; and an extrusion tool, which attaches to the plunger for extrusion of the sample from the coring body/storage chamber (see Fig. 2). Each En Core sampler is supplied with a protective moisture-proof bag for shipment to the laboratory.

5.2 Cooler with ice or cold packs, or refrigerated compartment regulated at  $4 \pm 2^\circ\text{C}$  and/or a freezer compartment regulated at a temperature within the range of  $-7$  to  $-21^\circ\text{C}$ .

5.3 Minimum/Maximum Thermometer Temperature Monitor—This is any thermometer device that registers the minimum and maximum temperatures reached during any a given period of time in  $^\circ\text{C}$  and has a range that includes the specified storage temperature in divisions of  $1^\circ\text{C}$ , such as a minimum/maximum thermometer or temperature data logger.

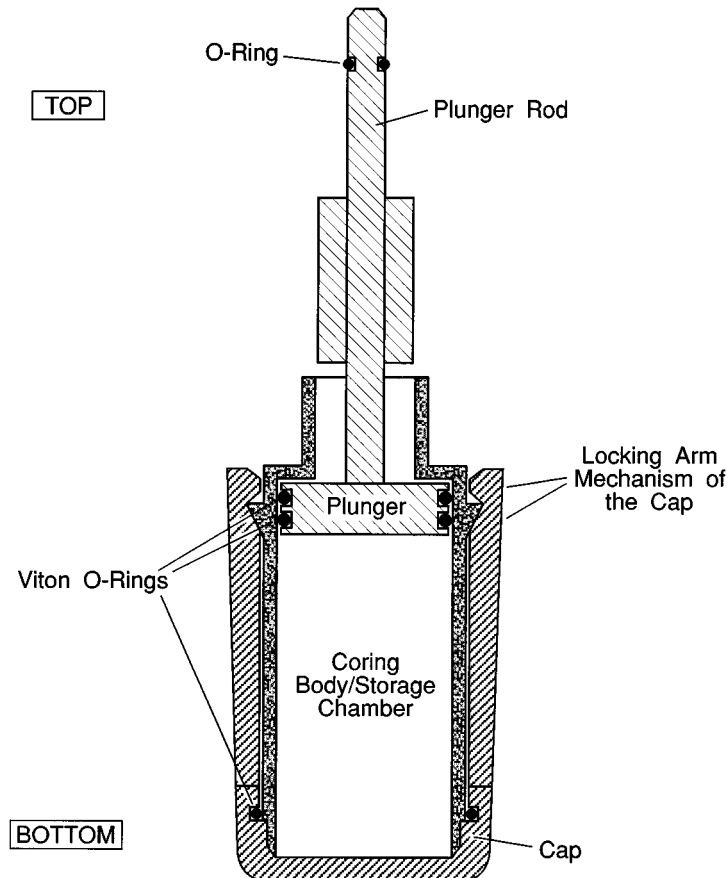

FIG. 1 Components of the En Core Sampler

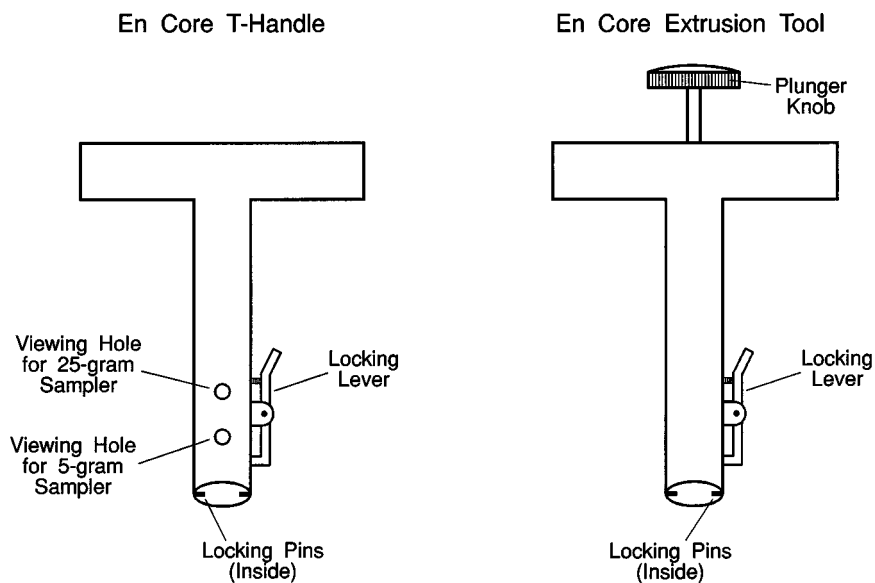

FIG. 2 Reusable Attachments to the En Core Sampler

## 6. Procedure

6.1 The size of the En Core sampler used is determined by the size of the sample required by the laboratory procedure that will be used to analyze the sample. If a sample size of approximately 5 g is required for analysis, the 5-g En Core sampler, and not the 25-g device, should be used to collect and store the sample. Subsampling from the En Core devices should not be performed to obtain smaller sample sizes for analysis.

6.2 If volatile contaminant levels in the soil being sampled are not known, it is recommended that three samples be collected at each sampling location using three En Core samplers. If determination of moisture content is required for reporting sample results on a dry weight basis, a fourth sample should be collected from each sampling location using a suitable container. The proper sample preparation method for low-level or high-level volatile analysis<sup>7,8</sup> can be determined by screening one of the three samples collected in the En Core samplers for high or low concentrations of VOCs. If a high concentration is present, one of the remaining samples in the En Core devices can be extruded into methanol for high-level analysis; if a low concentration is present, the two remaining samples in the En Core devices can be extruded into two appropriate vials for low-level analysis giving an additional low-level sample for analysis, if needed. For guidance on sample collection, sample handling, and sample preparation methods for volatile organic analysis, see Practice Guide D 4547. For quality assurance considerations related to field sampling, see Guide D 4687.

6.3 As stated in 4.8, the En Core device cannot be used for sampling cemented material, consolidated material, or material having fragments coarse enough to interfere with proper coring techniques.

6.4 *Sample Collection*—The manufacturer’s specific instructions for operating the En Core sampler and T-handle to collect a soil sample should be followed. The steps involved in sample collection using the En Core sampler are given below.

6.4.1 Before collecting a sample in the En Core sampler, the plunger rod (see Fig. 1) should be positioned so that the plunger can be moved freely from the top to the bottom of the coring body/storage chamber. For sample collection, the T-handle (see Fig. 2) should be attached to the sampler, and the plunger should be positioned so that the bottom of the plunger is flush with the bottom of the coring body/storage chamber. This prevents air from being trapped in the device during sample collection. When inserting a coring device into a surface for sample collection, air should not be trapped behind the sample. If this occurs, air can pass through the soil causing VOCs to be lost, or it can cause the sample to be prematurely pushed from the coring device.

6.4.2 Sample collection should be performed as quickly as possible. Using the T-handle, push the En Core sampler into the soil until the coring body/storage chamber is completely full. It can be verified that the coring body/storage chamber is full by looking into the appropriate viewing hole (either 5 or 25-g) in the T-handle (see Fig. 2). The coring body/storage chamber is completely full if the small O-ring on the plunger rod (see Fig. 1) is centered in the T-handle viewing hole. If possible, look at the viewing hole while the device is in the soil to check if the coring body/storage chamber is completely full. If it is not possible to view the hole when the device is in the soil, remove the sampler from the soil to view the hole. If the coring body/storage chamber is not completely full, quickly insert the device back into the same sampling spot and push harder to fill the coring body/storage chamber.

<sup>7</sup> U.S. EPA, 1996, Method 5035: Closed-System Purge-and-Trap and Extraction for Volatile Organics in Soil and Waste Samples. *Test Methods for Evaluating Solid Waste: Physical/Chemical Methods (SW-846)*, Vol 1B, Final Update III.

<sup>8</sup> U.S. EPA, 1996, Method 5021: Volatile Organic Compounds in Soils and Other Solid Matrices Using Equilibrium Headspace Analysis. *Test Methods for Evaluating Solid Waste: Physical/Chemical Methods (SW-846)*, Vol 1B, Final Update III.

When the coring body/storage chamber is completely full, scrape a spatula across the bottom of the coring body/storage chamber so the surface of the soil in the sampler is flush with the opening of the coring body/storage chamber (see Note 2). Quickly wipe the external surface of the coring body/storage chamber with a clean tissue or cloth. After ensuring that the sealing surfaces are clean, cap the coring body/storage chamber while it is still on the T-handle. This is done by gently sliding the cap onto the coring body/storage chamber with a twisting motion. The cap is locked into position when the grooves on the locking arms seat over the ridge on the coring body/storage chamber (see Fig. 1). If the cap of the En Core sampler is difficult to lock into position, the O-ring in the cap (see Fig. 1) may be bent out of position, and a new cap should be used to seal the device. A bent O-ring in the cap may result in loss of VOCs from the stored sample (see 8.2.2). After the cap is locked into position, the T-handle is removed from the sampler, and the plunger is locked into position by rotating the plunger rod (see manufacturer's specific operating instructions).

NOTE 2—For drier soils that are difficult to compact in the sampler, scraping a spatula across the surface of the soil to make it flush with the opening of the coring body/storage chamber may loosen particles of the soil in the coring body/storage chamber. These particles may scatter when the device is capped and may affect the seal between the cap and coring body/storage chamber (see 8.2.2). Caution should be used when working with these types of soils to prevent this from happening.

6.4.3 A sample label showing the sample number is attached to the cap of the En Core sampler, and the sampler is placed in its protective moisture-proof shipping bag (provided with each En Core sampler). This bag has a label attached for recording sample name, date collected, comments, and sample number.

6.5 *Sample Storage*— The capped coring body immediately becomes a sealed sample storage chamber. A sample can be stored in the sealed coring body/storage chamber at  $4 \pm 2^\circ\text{C}$  for up to 48 h; at  $-12 \pm 2^\circ\text{C}$   $-7$  to  $-21^\circ\text{C}$  for up to 14 days; or at  $4 \pm 2^\circ\text{C}$  for up to 48 h followed by storage at  $-12 \pm 2^\circ\text{C}$   $-7$  to  $-21^\circ\text{C}$  for up to five days (see Appendix X1 and reports referenced in footnotes 4, 5, and 6 for information on the performance of the En Core sampler under these storage conditions).<sup>4,5,6</sup> Storage of samples in the En Core sampler at  $4 \pm 2^\circ\text{C}$  or  $-12 \pm 2^\circ\text{C}$   $-7$  to  $-21^\circ\text{C}$  for longer holding times than those listed above is an option, provided it can be shown that the longer storage time used does not influence the concentrations of the VOCs of interest in the samples, or that the data generated by analysis of the samples meet the DQOs (see Practice D 5792). Data showing performance of the En Core sampler as a storage chamber for samples of ~~three different soil types~~ stored under a variety of conditions, including  $4 \pm 2^\circ\text{C}$  for 48 h;  $4$   $-7 \pm 2^\circ\text{C}$   $1^\circ\text{C}$  for ~~seven~~ 14 days;  $4$   $-12 \pm 2^\circ\text{C}$  for 14 days;  $-12$   $-21 \pm 2^\circ\text{C}$  for ~~seven~~ 14 days;  $-12$   $4 \pm 2^\circ\text{C}$  for ~~14~~ 48 h followed by storage at  $-7 \pm 1^\circ\text{C}$  for five days;  $4 \pm 2^\circ\text{C}$  for 48 h followed by storage at  $-12 \pm 2^\circ\text{C}$  for five days; and  $4 \pm 2^\circ\text{C}$  for 48 h followed by storage at  $-12$   $-21 \pm 2^\circ\text{C}$  for ~~twelve days~~ five days, are given in Appendix X1.

6.5.1 Storage of samples at  $4 \pm 2^\circ\text{C}$  can be achieved by placing the protective shipping bag, in which the En Core sampler has been placed, in a cooler with ice; or cold packs, or in a refrigerated compartment regulated at  $4 \pm 2^\circ\text{C}$ . For storage at  $-12 \pm 2^\circ\text{C}$ ,  $-7$  to  $-21^\circ\text{C}$ , the En Core sampler should be stored in a freezer compartment regulated at  $-12 \pm 2^\circ\text{C}$ ; a temperature within the range of  $-7$  to  $-21^\circ\text{C}$ . A minimum/maximum temperature monitor, such as a minimum/maximum thermometer or temperature data logger should be placed with the samples during storage to verify that the temperature requirement is maintained.

6.6 Arrangements with the receiving laboratory for sample log in, sample handling, required storage conditions, and analysis should be made.

6.7 *Extrusion of the Soil Sample from the En Core Sampler*—The manufacturer's specific instructions for operating the En Core sampler and extrusion tool to extrude the soil sample from the coring body/storage chamber should be followed. The steps involved in sample extrusion from the En Core sampler are outlined in 6.7.1.

6.7.1 At the laboratory, the soil is transferred into the appropriate container without disturbing the integrity of the sample by removing the cap from the coring body/storage chamber and using the plunger to expel the soil into the receiving container (see Note 3). This is done by performing the following steps in accordance with the manufacturer's specific operating instructions: attach the extrusion tool (see Fig. 2) to the En Core sampler; rotate the extrusion tool plunger knob into position for sample extrusion; unlock the locking arms of the cap; carefully remove the cap from the sampler; and, push down on the plunger knob of the extrusion tool (see Fig. 2) to expel the sample from the coring body/storage chamber directly into the appropriate container for analysis or preservation (see Practice Guide D 4547). After the sample is expelled from the En Core sampler, the O-ring in the sampler cap should be inspected to make sure that the O-ring was not bent when the cap was placed on the coring body/storage chamber. A bent O-ring in the sampler cap can result in loss of VOCs from the stored sample and should be documented (see 8.2.2).

NOTE 3—Samples that have been stored at  $-12 \pm 2^\circ\text{C}$   $-7$  to  $-21^\circ\text{C}$  should be allowed to sit at room temperature for 2 to 3 min before extrusion from the En Core sampler, which will facilitate extrusion of the frozen sample from the device.

## 7. Report

7.1 For guidance on information that should be recorded for a sampling activity, see Guide D 4687.

## 8. Precision and Bias

8.1 *Precision*—The estimated percent relative standard deviations of low-level ( $<200 \mu\text{g}/\text{Kg}$ ) concentrations of methylene chloride ( $\text{MeCl}_2$ ), methyl tert-butyl ether (MTBE), 1,1-dichloroethane, cis-1,2-dichloroethylene (CDCE), chloroform, benzene, trichloroethylene (TCE), toluene, tetrachloroethylene (PCE), ethyl benzene, and o-xylene due to storage of spiked samples of two different soils in the 5-g and 25-g En Core samplers have been shown to range from 0 to 10 % for the following conditions:  $4 \pm 2^\circ\text{C}$  for 48 h;  $4 \pm 2^\circ\text{C}$  for seven days;  $-12 \pm 2^\circ\text{C}$  for seven days;  $-12 \pm 2^\circ\text{C}$  for 14 days;  $4 \pm 2^\circ\text{C}$  for 48 h followed by  $-12 \pm 2^\circ\text{C}$

2°C for five days; and 4 ± 2°C for 48 h followed by -12 ± 2°C for twelve days. For storage of samples at 4 ± 2°C for 14 days, these values range from 0 to 14 % for the compounds listed above. For vinyl chloride, the values range from 0 to 14 % for all of the storage conditions.<sup>5</sup>

8.2 *Bias*—No information can be given on the bias of the sampling/storage procedure described in this practice because there is no standard reference material for sampling soil for VOCs in the field.

8.2.1 Data have been generated to provide information on the performance of the En Core sampler for storage of soil samples spiked with VOCs at low-level concentrations of approximately 100 µg/Kg. Performance of the device for storage of the spiked soil at 4 ± 2°C for 48 h, at 4 ± 2°C for seven days, at 4 ± 2°C for 14 days, at -12 -7 ± 1°C for 14 days, at 4 ± 2°C for 48 h followed by storage at -7 ± 1°C for five days, at -12 ± 2°C for seven days, at -12 ± 2°C for 14 days, at 4 ± 2°C for 48 h followed by storage at -12 ± 2°C for five days, and at 4 ± 2°C for 48 h followed by storage at -12 -12 ± 2°C for 12 days, at -21 ± 2°C for 14 days, and at 4 ± 2°C for 48 h followed by storage at -21 ± 2°C for five days was has been evaluated. The data from this study these evaluations are shown in Appendix X1.<sup>6,9</sup> :

8.2.2 A study involving storage of soil samples spiked with VOCs at high-level concentrations of approximately 2,500 µg/Kg has also been conducted. The data and findings from this study are discussed in research report RR: D34-1012<sup>10</sup>.

8.2.3 Data showing the performance of the 25-g disposable En Core sampler to store soil samples spiked with EPA Method 1311<sup>11</sup> volatile organic analytes are shown in Appendix X2.<sup>9</sup> Storage conditions used were 14 days at 4 ± 2°C, 14 days at -12 -12 ± 2°C, and 48 h at 4 ± 2°C followed by 12 days at -12 -12 ± 2°C.

## 9. Keywords

9.1 En Core sampler; soil sampling; storage of soil samples; volatile organic compounds (VOCs); VOC analysis

<sup>9</sup> A copy

<sup>9</sup> Copies of the research reports on the studies described in Appendix X1 and Appendix X2 is are available from ASTM Headquarters. Request RR: D34-1013 and RR: D34-1015. RR: D34-1013 also gives information on the study described in Appendix X2.

<sup>10</sup> A copy of the research report on the study described in 8.2.2 is available from ASTM Headquarters. Request RR:D34-1012.

<sup>11</sup> U.S. EPA, 1992, Method 1311, Toxicity Characteristic Leaching Procedure. *Test Methods for Evaluating Solid Waste: Physical/Chemical Methods (SW-846)*, Vol: 1C.

## APPENDICES

### (Nonmandatory Information)

#### X1. PERFORMANCE OF THE EN CORE SAMPLER TO STORE LOW-LEVEL VOC-SPIKED SOIL SAMPLES

X1.1 A study was conducted to evaluate the performance of the 5- and 25-g En Core samplers to store three different soil types spiked with an aqueous solution containing eleven volatile organic compounds (VOCs). The En Core samplers used in this study were manufactured at the end of 1999 and in 2000. The 5-g devices that were used represent lot numbers K119333, K110073, K110167, and K110259. The 25-g devices that were used represent lot numbers K119349, K110053, and K110154. The manufacturer can be contacted for information on these lot numbers.

X1.1.1 The soils used in the study are representative of different environments and contained native microbial populations. They are a river bank soil having 49 % sand, 26 % silt, 24 % clay, 5.3 % organic material, approximately 14 % moisture, and a dehydrogenase (microbial) activity of 22 mg total product formed (TPF)/g/24 h; a mountain soil having 75 % sand, 13 % silt, 12 % clay, 4.3 % organic material, approximately 12 % moisture, and a dehydrogenase activity of 11 mg TPF/g/24 h; and, a prairie soil having 67 % sand, 17 % silt, 16 % clay, 1.5 % organic material, approximately 8 % moisture, and a dehydrogenase activity of 17 mg TPF/g/24 h.

X1.1.2 The VOCs used in the study are methylene chloride (MeCl<sub>2</sub>), methyl tert-butyl ether (MTBE), 1,1-dichloroethane, *cis*-1,2-dichloroethylene (CDCE), chloroform, benzene, trichloroethylene (TCE), toluene, tetrachloroethylene, (PCE), ethyl benzene, and *o*-xylene. These compounds were selected as the analytes of interest because they are representative of halogenated and aromatic compounds that are of environmental concern.

X1.1.3 In the study, soil samples were collected in the En Core samplers from a large container of loose soil and then spiked with an aqueous solution containing the compounds listed in X1.1.2. The spiking solution was prepared by adding 250 µL of gasoline to approximately 80 mL of VOC-free water in a 100-mL volumetric flask and diluting to volume. The mixture was stirred for 24 h, and then the gasoline was separated from the water using a separatory funnel. The resulting gasoline-saturated water was added to a 40-mL VOA vial, and a methanol solution containing the compounds of interest, except for benzene and toluene, was injected into the gasoline-saturated water. The benzene and toluene present in the spiking solution came totally from the gasoline-saturated water. The 5-g samples were spiked with 100 µL of spiking solution, and the 25-g samples were spiked with 0.5 mL of the spiking solution to give an approximate concentration of 100 µg/Kg of each analyte of interest in the samples, with the exception of benzene, toluene, and *o*-xylene. Because of their presence in the gasoline-saturated water, the concentrations of

**TABLE X1.1 Storage Conditions for Low-Level Testing of the Disposable En Core Samplers**

Storage Times and Conditions	Number of Samples
No Storage (Time-zero)	5 samples
48 h in a cooler at 4 ± 2°C	5 samples
48 h in a cooler at 4 ± 2°C, then 5 days at 4 ± 2°C in a refrigerator	5 samples
48 h in a cooler at 4 ± 2°C, then 5 days at -12 ± 2°C in a freezer	5 samples
48 h in a cooler at 4 ± 2°C, then 5 days at -12 ± 2°C in a freezer	5 samples
7 days at -12 ± 2°C in a freezer	5 samples
7 days at -12 ± 2°C in a freezer	5 samples
48 h in a cooler at 4 ± 2°C, then 12 days at 4 ± 2°C in a refrigerator	5 samples
48 h in a cooler at 4 ± 2°C, then 12 days at -12 ± 2°C in a freezer	5 samples
48 h in a cooler at 4 ± 2°C, then 12 days at -12 ± 2°C in a freezer	5 samples
14 days at -12 ± 2°C in a freezer	5 samples
14 days at -12 ± 2°C in a freezer	5 samples

**TABLE X1.2 Average Percent Recoveries of Low-Level<sup>A</sup> VOCs from Samples of River Bank Soil<sup>B</sup> Stored in 5-g En Core Samplers**

Storage Conditions:	4 ± 2°C/ 48 h	4 ± 2°C/ 7 Days	4 ± 2°C/ 14 Days	-12 ± 2°C/ 7 Days	-12 ± 2°C/ 14 Days	4 ± 2°C 48 h/ -12 ± 2°C 5 Days	4 ± 2°C 48 h/ -12 ± 2°C 12 Days
VOCs							
MeCl <sub>2</sub>	103 <sup>C</sup> (15) <sup>D</sup>	60 (16)	48 (44)	99 (4)	60 (32)	103 (4)	92 (22)
MTBE	105 (3)	109 (8)	81 (18)	104 (3)	84 (9)	93 (5)	90 (12)
1,1-Dichloroethane	107 (3)	99 (6)	78 (24)	102 (3)	96 (10)	92 (5)	98 (5)
CDCE	104 (3)	97 (3)	80 (14)	101 (7)	95 (8)	91 (7)	94 (12)
Chloroform	99 (7)	104 (6)	83 (15)	96 (6)	93 (6)	94 (7)	94 (12)
Benzene	104 (5)	92 (4)	77 (13)	104 (7)	97 (6)	90 (4)	94 (12)
TCE	105 (6)	98 (3)	85 (8)	102 (8)	98 (3)	97 (7)	99 (4)
Toluene	92 (7)	95 (5)	74 (8)	108 (7)	102 (2)	93 (8)	97 (10)
PCE	97 (10)	100 (4)	85 (6)	99 (5)	96 (5)	100 (10)	96 (7)
Ethyl benzene	96 (8)	95 (7)	85 (6)	105 (7)	94 (4)	99 (8)	101 (10)
o-Xylene	99 (7)	94 (6)	79 (6)	103 (7)	97 (3)	98 (7)	100 (8)

<sup>A</sup> Concentrations of the VOCs in the samples were ~100 µg/Kg, except for benzene concentrations ranging from ~70 to ~300 µg/Kg, toluene concentrations ranging from ~300 to ~900 µg/Kg, and o-xylene concentrations at ~200 µg/Kg.

<sup>B</sup> The river bank soil is 49 % sand, 26 % silt, 24 % clay, 5.3 % organic material, and ~14 % moisture.

<sup>C</sup> Average percent recovery is based on mean concentration values determined for five time-zero samples and five stored samples minus outlier data points.

<sup>D</sup> The value in parentheses is the percent relative standard deviation of the concentration values in the stored samples. The percent relative standard deviation of the concentration values in the time-zero samples ranged from 2 to 11 %, except for methylene chloride for which values ranged from 5 to 19 %.

benzene ranged from approximately 70 to 300 µg/Kg and the concentrations of toluene ranged from approximately 300 to 900 µg/Kg in the spiked soil samples. Additional o-xylene and ethyl benzene were also added to the spiking solution by the gasoline-saturated water. This resulted in o-xylene and ethyl benzene concentrations in the spiked soil samples at approximately 200 µg/Kg and approximately 100 µg/Kg, respectively.

X1.1.4 After all samples were spiked and capped, five random samples for each soil type were extruded from each size of En Core sampler into methanol for analysis to give time-zero concentrations of the analytes of interest. The remaining samples were stored under the storage conditions shown in Table X1.1. Storage temperatures were monitored to make sure they were at the specified temperature. The temperatures in the coolers and refrigerator used to store the samples at 4°C and in the freezer used to store the samples at -12°C were monitored using minimum/maximum thermometers. After the samples were held for the appropriate times, they were extruded into methanol for extraction and analysis. The methanol extracts of the samples were

**TABLE X1.3 Average Percent Recoveries of Low-Level<sup>A</sup> VOCs from Samples of River Bank Soil<sup>B</sup> Stored in 25-g En Core Samplers**

Storage Conditions:	4 ± 2°C/ 48 h	4 ± 2°C/ 7 Days	4 ± 2°C/ 14 Days	-12 ± 2°C/ 7 Days	-12 ± 2°C/ 14 Days	4 ± 2°C 48 h/ -12 ± 2°C 5 Days	4 ± 2°C 48 h/ -12 ± 2°C 12 Days
VOCs							
MeCl <sub>2</sub>	96 <sup>C</sup> (5) <sup>D</sup>	94 (8)	88 (8)	94 (2)	93 (5)	105 (6)	72 (17)
MTBE	97 (6)	108 (6)	102 (5)	104 (10)	83 (2)	108 (4)	74 (12)
1,1-Dichloroethane	98 (3)	102 (6)	95 (3)	103 (3)	104 (2)	102 (3)	83 (10)
CDCE	98 (2)	97 (5)	84 (5)	101 (4)	100 (3)	100 (3)	80 (12)
Chloroform	98 (1)	102 (6)	96 (6)	102 (1)	102 (3)	102 (3)	77 (10)
Benzene	97 (2)	97 (7)	88 (4)	95 (3)	107 (5)	98 (1)	86 (11)
TCE	100 (3)	106 (9)	97 (1)	98 (3)	103 (4)	102 (3)	90 (11)
Toluene	98 (4)	102 (5)	92 (5)	99 (5)	103 (4)	105 (1)	81 (11)
PCE	100 (3)	105 (4)	97 (6)	101 (5)	110 (6)	100 (4)	90 (4)
Ethyl benzene	98 (4)	96 (7)	88 (1)	101 (1)	99 (4)	96 (4)	93 (10)
o-Xylene	99 (2)	96 (7)	92 (3)	101 (1)	99 (4)	98 (3)	88 (11)

<sup>A</sup> Concentrations of the VOCs in the samples were ~100 µg/Kg, except for benzene concentrations ranging from ~70 to ~300 µg/Kg, toluene concentrations ranging from ~300 to ~900 µg/Kg, and o-xylene concentrations at ~200 µg/Kg.

<sup>B</sup> The river bank soil is 49 % sand, 26 % silt, 24 % clay, 5.3 % organic material, and ~14 % moisture.

<sup>C</sup> Average percent recovery is based on mean concentration values determined for five time-zero samples and five stored samples minus outlier data points.

<sup>D</sup> The value in parentheses is the percent relative standard deviation of the concentration values in the stored samples. The percent relative standard deviation of the concentration values in the time-zero samples ranged from 1 to 15 % for all of the tests using the river bank soil in the 25-g devices.

analyzed using EPA Method 8260B<sup>12</sup> and 5030B<sup>13</sup> :

X1.1.5 To evaluate the data, the mean concentrations of the analytes of interest in the stored samples were compared to their mean concentrations in the time-zero samples by calculating average percent recovery. Before average percent recovery was calculated, the data sets were evaluated for outlier data points as described in Practice D 2777 and Grubbs.<sup>14</sup>

X1.1.6 The data generated by this testing are specific to the experimental design of the study. The data give information on the performance of the En Core samplers for storing soil samples collected from loose soil, spiked with a gasoline-saturated water solution containing selected analytes of interest, and then stored under specific storage conditions. The data generated by this testing also are specific to the soils used in the study, the analytes of interest, the analyte concentrations, and the storage conditions that were evaluated. For other soil types, analytes, analyte concentrations, and storage conditions, these data may not apply.

X1.1.7 The average percent recoveries of the VOCs of interest from samples of the river bank soil stored in the 5-g En Core samplers are shown in Table X1.2; and the average percent recoveries of the VOCs of interest from samples of the river bank soil stored in the 25-g En Core samplers are shown in Table X1.3. In each of these tables, the percent relative standard deviation of the concentration values in the stored samples is given in parentheses next to the corresponding average percent recovery value. The percent relative standard deviation of the concentration values in the time-zero samples is given in a footnote to each of the tables.

X1.1.7.1 As shown in Table X1.2 for the 5-g sampler, all of the VOCs of interest in this study have average percent recovery values of 90 % or greater for storage of the spiked river bank soil samples at 4 ± 2°C for 48 h, for storage at -12 ± 2°C for seven days, for storage at 4 ± 2°C for 48 h followed by storage at -12 ± 2°C for five days, and for storage at 4 ± 2°C for 48 h followed by storage at -12 ± 2°C for 12 days. The mean of the 44 average percent recovery values listed in Table X1.2 for the analytes of interest for these four storage conditions is 99 % recovery with a standard deviation of 5 % and a percent relative standard deviation of 5 %. For storage at 4 ± 2°C for seven days and at -12 ± 2°C for 14 days, average percent recovery values for all of the VOCs of interest are greater than 90 %, except for MeCl<sub>2</sub>, which has an average percent recovery of 60 % for both storage conditions, and MTBE, which has an average percent recovery of 84 % for storage at -12 ± 2°C for 14 days. For storage at 4 ± 2°C for 14 days, average percent recovery values for the compounds of interest range from 74 % to 85 %, except for MeCl<sub>2</sub>, which has an average percent recovery value of 48 %.

X1.1.7.2 As shown in Table X1.3, for the 25-g sampler, all of the VOCs of interest have average percent recovery values greater than 90 % for storage of the spiked river bank soil samples at 4 ± 2°C for 48 h, for storage at 4 ± 2°C for seven days, for storage at -12 ± 2°C for seven days, and for storage at 4 ± 2°C for 48 h followed by storage at -12 ± 2°C for five days. The mean of the 44 average percent recovery values listed in Table X1.3 for the analytes of interest for these four storage conditions is 100 % recovery with a standard deviation of 4 % and a percent relative standard deviation of 4 %. For storage at -12 ± 2°C for 14 days, the average percent recovery values for all of the analytes are greater than 90 %, except for MTBE, which has an average percent recovery value of 83 %. For storage at 4 ± 2°C for 14 days, the average percent recovery values for all of the

<sup>12</sup> This practice is under the jurisdiction of ASTM Committee D34 on Waste Management and is the direct responsibility of Subcommittee D34.01.03 on Sampling Equipment.

Current edition approved Feb. 1, 2004. Published April 2004. Originally approved in 1999 as D 6418 – 99. Last previous edition approved in 2003 as D 6418 – 03.

<sup>13</sup> U.S. EPA, 1996, Method 5030B:Purge-and-Trap for Aqueous Samples. *Test Methods for Evaluating Solid Waste: Physical/Chemical Methods (SW-846)*, Vol 1B, Final Update III.

<sup>14</sup> Grubbs, F. E., "Sample Criteria for Testing Outlying Observations," *Annals of Mathematical Statistics*, Vol 21, March 1950, pp. 27-58.

analytes are greater than 80 %. As shown in Table X1.3, for storage at  $4 \pm 2^\circ\text{C}$  for 48 h followed by storage at  $-12 \pm 2^\circ\text{C}$  for 12 days, the average percent recovery values for the analytes of interest are also greater than 80 %, except for  $\text{MeCl}_2$  at 72 % recovery, MTBE at 74 % recovery, and chloroform at 77 % recovery.

X1.1.8 The average percent recoveries of the VOCs of interest from samples of the mountain soil stored in the 5-g En Core samplers are shown in Table X1.4; and the average percent recoveries of the VOCs of interest from samples of the mountain soil stored in the 25-g En Core samplers are shown in Table X1.5. In each of these tables, the percent relative standard deviation of the concentration values in the stored samples is given in parentheses next to the corresponding average percent recovery value. The percent relative standard deviation of the concentration values in the time-zero samples is given in a footnote to each of the tables.

X1.1.8.1 As shown in Table X1.4 for the En Core sampler, all of the VOCs of interest in this study have average percent recovery values greater than 90 % for storage of the spiked mountain soil samples at  $-12 \pm 2^\circ\text{C}$  for seven days and for storage at  $4 \pm 2^\circ\text{C}$  for 48 h followed by storage at  $-12 \pm 2^\circ\text{C}$  for five days. In addition, for storage at  $4 \pm 2^\circ\text{C}$  for 48 h, all of the analytes of interest have average percent recovery values of 90 % or greater, except for CDCE and chloroform, which have average percent recovery values of 87 %. The mean of the 33 average percent recovery values listed in Table X1.4 for the analytes of interest for the three storage conditions discussed above is 98 % recovery with a standard deviation of 6 % and a percent relative standard deviation of 6 %. For storage at  $-12 \pm 2^\circ\text{C}$  for 14 days and at  $4 \pm 2^\circ\text{C}$  for 48 h followed by storage at  $-12 \pm 2^\circ\text{C}$  for 12 days, average percent recovery values are also greater than 90 %, except for  $\text{MeCl}_2$ , which has an average percent recovery of 82 % for storage at  $-12 \pm 2^\circ\text{C}$  for 14 days and 74 % for storage at  $4 \pm 2^\circ\text{C}$  for 48 h followed by storage at  $-12 \pm 2^\circ\text{C}$  for 12 days. For storage at  $4 \pm 2^\circ\text{C}$  for seven days, the analytes of interest have average percent recovery values greater than 80 %, except for CDCE at 75 % and toluene at 74 %. Lastly, for storage at  $4 \pm 2^\circ\text{C}$  for 14 days, average percent recovery values are 100 % for MTBE; 88 % for 1,1-dichloroethane, TCE, and PCE; 76 % to 84 % for chloroform, benzene, toluene, CDCE, ethyl benzene, and o-xylene; and 71 % for  $\text{MeCl}_2$ .

X1.1.8.2 As shown in Table X1.5 for the 25-g En Core sampler, all of the VOCs of interest have average percent recovery values greater than 90 % for storage of the spiked mountain soil samples under all of the storage conditions used in this study. The only exceptions are  $\text{MeCl}_2$  at 88 % recovery and CDCE at 89 % recovery for storage at  $4 \pm 2^\circ\text{C}$  for seven days, and benzene at 90 % recovery and toluene at 87 % recovery for storage at  $4 \pm 2^\circ\text{C}$  for 14 days. The mean of the 77 average percent recovery values listed in Table X1.5 for the seven storage conditions is 99 % recovery with a standard deviation of 4 % and a percent relative standard deviation of 4 %.

X1.1.9 The average percent recoveries of the VOCs of interest from samples of the prairie soil stored in the 5-g En Core samplers are shown in Table X1.6; and the average percent recoveries of the VOCs of interest from samples of the prairie soil stored in the 25-g En Core samplers are shown in Table X1.7. In each of these tables, the percent relative standard deviation of the concentration values in the stored samples is given in parentheses next to the corresponding average percent recovery value. The percent relative standard deviation of the concentration values in the time-zero samples is given in a footnote to each of the tables.

#### X1.1.9.1 As

X1.1.8.2 As shown in Table X1.6 and Table X1.7, vinyl chloride was added to the list of analytes of interest X1.5 for the testing involving the prairie soil. This was done because in previous testing involving the prairie soil (see 8.2.2), the seals of some of the En 25-g En Core samplers were affected by particles of this dry, loose soil, which scattered during capping of the devices. Because

**TABLE X1.4 Average Percent Recoveries of Low-Level<sup>A</sup> VOCs from Samples of Mountain Soil<sup>B</sup> Stored in 5-g En Core Samplers**

Storage Conditions:	$4 \pm 2^\circ\text{C}/$ 48 h	$4 \pm 2^\circ\text{C}/$ 7 Days	$4 \pm 2^\circ\text{C}/$ 14 Days	$-12 \pm 2^\circ\text{C}/$ 7 Days	$-12 \pm 2^\circ\text{C}/$ 14 Days	$4 \pm 2^\circ\text{C}$ 48 h/ $-12 \pm 2^\circ\text{C}$ 5 Days	$4 \pm 2^\circ\text{C}$ 48 h/ $-12 \pm 2^\circ\text{C}$ 12 Days
VOCs							
$\text{MeCl}_2$	108 <sup>C</sup> (4) <sup>D</sup>	86 (2)	71 (13)	110 (6)	82 (13)	108 (10)	74 (10)
MTBE	105 (6)	98 (9)	100 (1)	103 (1)	100 (2)	101 (1)	100 (2)
1,1-Dichloroethane	90 (8)	86 (11)	88 (2)	99 (7)	100 (8)	99 (6)	96 (6)
CDCE	87 (6)	75 (3)	77 (3)	97 (5)	99 (8)	92 (6)	91 (7)
Chloroform	87 (5)	85 (2)	76 (0.3)	107 (1)	103 (7)	102 (3)	105 (6)
Benzene	92 (6)	81 (10)	76 (7)	94 (6)	94 (7)	93 (4)	92 (2)
TCE	97 (6)	90 (10)	88 (6)	98 (7)	100 (7)	103 (4)	103 (5)
Toluene	91 (6)	74 (4)	76 (6)	96 (4)	100 (4)	92 (3)	97 (3)
PCE	98 (7)	92 (9)	88 (8)	94 (2)	99 (6)	102 (4)	104 (4)
Ethyl benzene	97 (6)	83 (3)	82 (4)	100 (3)	98 (5)	98 (3)	98 (3)
o-Xylene	98 (4)	92 (11)	84 (3)	102 (3)	102 (6)	103 (3)	99 (3)

<sup>A</sup> Concentrations of the VOCs in the samples were ~100 µg/Kg, except for benzene concentrations ranging from ~70 to ~300 µg/Kg, toluene concentrations ranging from ~300 to ~900 µg/Kg, and o-xylene concentrations at ~200 µg/Kg.

<sup>B</sup> The mountain soil is 75 % sand, 13 % silt, 12 % clay, 4.3 % organic material, and ~12 % moisture.

<sup>C</sup> Average percent recovery is based on mean concentration values determined for five time-zero samples and five stored samples minus outlier data points. Testing was performed 5/2000 through 6/2000.

<sup>D</sup> The value in parentheses is the percent relative standard deviation of the concentration values in the stored samples. The percent relative standard deviation of the concentration values in the time-zero samples ranged from 1 to 9 %, except for methylene chloride, for which the percent relative standard deviation value was 21 % for storage conditions of  $4 \pm 2^\circ\text{C}/48$  h,  $4 \pm 2^\circ\text{C}/7$  days,  $4 \pm 2^\circ\text{C}$  48 h/ $-12 \pm 2^\circ\text{C}$  5 days, and  $-12 \pm 2^\circ\text{C}/7$  days; and 8 % for the other storage conditions.

**TABLE X1.5 Average Percent Recoveries of Low-Level<sup>A</sup> VOCs from Samples of Mountain Soil<sup>B</sup> Stored in 25-g En Core Samplers**

Storage Conditions:	4 ± 2°C/ 48 h	4 ± 2°C/ 7 Days	4 ± 2°C/ 14 Days	-12 ± 2°C/ 7 Days	-12 ± 2°C/ 14 Days	4 ± 2°C 48 h/ -12 ± 2°C 5 Days	4 ± 2°C 48 h/ -12 ± 2°C 12 Days
VOCs							
MeCl <sub>2</sub>	97 <sup>C</sup> (5) <sup>D</sup>	88 (5)	91 (4)	102 (4)	98 (5)	104 (5)	97 (7)
MTBE	103 (3)	101 (0)	103 (4)	101 (2)	100 (3)	102 (3)	100 (4)
1,1-Dichloroethane	98 (2)	94 (2)	98 (3)	100 (1)	100 (3)	99 (2)	99 (4)
CDCE	97 (1)	89 (3)	91 (5)	99 (1)	100 (2)	98 (1)	98 (7)
Chloroform	98 (4)	91 (1)	102 (2)	99 (2)	104 (3)	96 (1)	101 (3)
Benzene	99 (2)	91 (3)	90 (2)	102 (2)	103 (3)	98 (1)	101 (4)
TCE	100 (2)	100 (1)	97 (3)	101 (2)	99 (3)	100 (2)	102 (3)
Toluene	100 (4)	93 (2)	87 (4)	100 (3)	99 (4)	98 (3)	98 (4)
PCE	101 (1)	100 (1)	100 (3)	98 (2)	101 (4)	99 (2)	102 (4)
Ethyl benzene	103 (1)	98 (1)	92 (2)	99 (4)	98 (5)	101 (5)	100 (3)
o-Xylene	101 (2)	103 (1)	98 (3)	100 (1)	102 (3)	102 (3)	97 (3)

<sup>A</sup> Concentrations of the VOCs in the samples were ~100 µg/Kg, except for benzene concentrations ranging from ~70 to ~300 µg/Kg, toluene concentrations ranging from ~300 to ~900 µg/Kg, and o-xylene concentrations at ~200 µg/Kg.

<sup>B</sup> The mountain soil is 75 % sand, 13 % silt, 12 % clay, 4.3 % organic material, and ~12 % moisture.

<sup>C</sup> Average percent recovery is based on mean concentration values determined for five time-zero samples and five stored samples minus outlier data points. Testing was performed 6/2000 through 7/2000.

<sup>D</sup> The value in parentheses is the percent relative standard deviation of the concentration values in the stored samples. The percent relative standard deviation of the concentration values in the time-zero samples ranged from 1 to 7 % for the tests using the mountain soil in the 25-g devices.

**TABLE X1.6 Average Percent Recoveries of Low-Level<sup>A</sup> VOCs from Samples of Prairie Soil<sup>B</sup> Stored in 5-g En Core Samplers**

Storage Conditions:	4 ± 2°C/ 48 h	4 ± 2°C/ 7 Days	4 ± 2°C/ 14 Days	-12 ± 2°C/ 7 Days	-12 ± 2°C/ 14 Days	4 ± 2°C 48 h/ -12 ± 2°C 5 Days	4 ± 2°C 48 h/ -12 ± 2°C 12 Days
VOCs							
Vinyl Chloride	87 <sup>C</sup> (2) <sup>D</sup>	93 (9)	76 (10)	103 (10)	91 (9)	103 (3)	87 (16)
MeCl <sub>2</sub>	87 (3)	88 (8)	76 (13)	95 (3)	95 (8)	102 (1)	89 (9)
MTBE	94 (2)	101 (7)	99 (4)	102 (5)	103 (4)	101 (5)	103 (6)
1,1-Dichloroethane	91 (4)	85 (9)	73 (9)	100 (4)	95 (8)	97 (2)	89 (8)
CDCE	87 (2)	75 (9)	62 (15)	94 (9)	88 (6)	89 (1)	81 (11)
Chloroform	90 (1)	87 (7)	77 (8)	95 (1)	94 (6)	96 (3)	92 (9)
Benzene	89 (4)	71 (10)	53 (10)	98 (5)	95 (5)	91 (2)	85 (9)
TCE	90 (5)	73 (7)	63 (12)	97 (6)	97 (6)	93 (3)	91 (9)
Toluene	80 (5)	57 (15)	32 (13)	93 (2)	90 (8)	85 (2)	74 (13)
PCE	90 (5)	72 (10)	56 (13)	96 (5)	100 (5)	91 (5)	93 (10)
Ethyl benzene	87 (5)	65 (15)	36 (12)	98 (11)	99 (4)	89 (3)	86 (8)
o-Xylene	85 (6)	58 (15)	37 (12)	96 (4)	98 (4)	84 (6)	84 (8)

<sup>A</sup> Concentrations of the VOCs in the samples were ~100 µg/Kg, except for benzene concentrations ranging from ~70 to ~300 µg/Kg, toluene concentrations ranging from ~300 to ~900 µg/Kg, and o-xylene concentrations at ~200 µg/Kg.

<sup>B</sup> The prairie soil is 67 % sand, 17 % silt, 16 % clay, 1.5 % organic material, and ~8 % moisture.

<sup>C</sup> Average percent recovery is based on mean concentration values determined for five time-zero samples and five stored samples minus outlier data points.

<sup>D</sup> The value in parentheses is the percent relative standard deviation of the concentration values in the stored samples. The percent relative standard deviation of the concentration values in the time-zero samples ranged from 1 to 14 % for all of the tests using the prairie soil in the 5-g devices.

vinyl chloride is a very volatile compound, average percent recovery values for this analyte serve as a good indicator of loss from the samplers by volatilization due to compromised seals. In this study, to reduce the possibility of particles scattering, the surface of the prairie soil samples in the En Core devices were patted down prior to capping.

X1.1.9.2 As shown in Table X1.6 for the 5-g En Core sampler, all of the VOCs of interest have average percent recovery values equal to or greater than 90 % for storage of the spiked prairie mountain soil samples at -12 ± 2°C for seven days, and for storage at -12 ± 2°C for 14 days, except for CDCE, which has an average percent recovery of 88 % for storage at -12 ± 2°C for 14 days. The mean of the 24 average percent recovery values listed in Table X1.6 for the analytes of interest for these two storage conditions is 96 % recovery with a standard deviation of 4 % and a percent relative standard deviation of 4 %. In addition, under all of the VOCs of interest have average percent recovery values of 80 % or greater for storage of the spiked prairie soil samples at 4 ± 2°C for 48 h, for storage at 4 ± 2°C for 48 h followed by storage at -12 ± 2°C for five days, and for storage at 4 ± 2°C for 48 h followed by storage at -12 ± 2°C for 12 days, except for toluene, which has an average percent recovery of 74 % for storage at 4 ± 2°C for 48 h followed by storage at -12 ± 2°C for 12 days. The mean of the 36 average percent recovery values listed in Table X1.6 for the analytes of interest for these three storage conditions is 90 % recovery with a standard deviation of 6 % and a percent relative standard deviation of 7 %. For storage of the spiked prairie soil used in the 5-g En Core sampler at 4 ± 2°C for seven days, average percent recovery values for vinyl chloride and MTBE are 93 % and 101 %, respectively. In addition, for this storage condition, average percent recovery values range from 85 % to 88 % for 1,1-dichloroethane, chloroform, and study. The only exceptions are MeCl<sub>2</sub>; from 71 % to 75 % at 88 % recovery and CDCE at 89 % recovery for benzene, PCE, TCE, storage at 4 ± 2°C for seven days, and CDCE; benzene at 90 % recovery and toluene at 87 % recovery for storage at 4 ± 2°C for 14 days. The

**TABLE X1.7 Average Percent Recoveries of Low-Level<sup>A</sup> VOCs from Samples of Prairie Soil<sup>B</sup> Stored in 25-g En Core Samplers**

Storage Conditions:	4 ± 2°C/ 48 h	4 ± 2°C/ 7 Days	4 ± 2°C/ 14 Days	-12 ± 2°C/ 7 Days	-12 ± 2°C/ 14 Days	4 ± 2°C 48 h/ -12 ± 2°C 5 Days	4 ± 2°C 48 h/ -12 ± 2°C 12 Days
VOCs							
Vinyl Chloride	95 <sup>C</sup> (8) <sup>D</sup>	92 (9)	87 (3)	105 (3)	88 (22)	93 (32)	92 (9)
MeCl <sub>2</sub>	93 (8)	73 (11)	72 (8)	82 (12)	86 (7)	82 (10)	89 (5)
MTBE	97 (8)	99 (9)	94 (4)	102 (2)	100 (6)	102 (3)	99 (2)
1,1-Dichloroethane	94 (5)	89 (6)	83 (4)	99 (6)	98 (6)	99 (8)	95 (3)
CDCE	94 (5)	82 (2)	75 (7)	95 (7)	95 (5)	95 (9)	91 (3)
Chloroform	97 (4)	89 (3)	89 (3)	96 (6)	102 (3)	98 (7)	100 (4)
Benzene	91 (5)	83 (4)	71 (5)	101 (5)	97 (4)	101 (7)	92 (3)
TCE	95 (3)	80 (4)	75 (6)	100 (1)	97 (6)	97 (7)	94 (2)
Toluene	88 (1)	67 (4)	54 (12)	100 (4)	98 (4)	97 (6)	92 (13)
PCE	96 (3)	84 (4)	71 (6)	101 (5)	99 (3)	102 (6)	97 (3)
Ethyl benzene	95 (3)	71 (5)	60 (10)	97 (3)	97 (5)	95 (4)	93 (0)
o-Xylene	95 (2)	64 (1)	57 (10)	98 (1)	100 (4)	94 (5)	93 (4)

<sup>A</sup> Concentrations of the VOCs in the samples were ~100 µg/Kg, except for benzene concentrations ranging from ~70 to ~300 µg/Kg, toluene concentrations ranging from ~300 to ~900 µg/Kg, and o-xylene concentrations at ~200 µg/Kg.

<sup>B</sup> The prairie soil is 67 % sand, 17 % silt, 16 % clay, 1.5 % organic material, and ~8 % moisture.

<sup>C</sup> Average percent recovery is based on mean concentration values determined for five time-zero samples and five stored samples minus outlier data points.

<sup>D</sup> The value in parentheses is the percent relative standard deviation of the concentration values in the stored samples. The percent relative standard deviation of the concentration values in the time-zero samples ranged from 2 to 10 % for all of the tests using the prairie soil in the 25-g devices.

mean of the 77 average percent recovery values listed in Table X1.5 for the seven storage conditions is 99 % recovery with a standard deviation of 4 % and a percent relative standard deviation of 4 %.

X1.1.9 The average percent recoveries of the VOCs of interest from 57 % samples of the prairie soil stored in the 5-g En Core samplers are shown in Table X1.6; and the average percent recoveries of the VOCs of interest from samples of the prairie soil stored in the 25-g En Core samplers are shown in Table X1.7. In each of these tables, the percent relative standard deviation of the concentration values in the stored samples is given in parentheses next to the corresponding average percent recovery value. The percent relative standard deviation of the concentration values in the time-zero samples is given in a footnote to each of the tables.

X1.1.9.1 As shown in Table X1.6 and Table X1.7, vinyl chloride was added to the list of analytes of interest for the testing involving the prairie soil. This was done because in previous testing involving the prairie soil (see 8.2.2), the seals of some of the En Core samplers were affected by particles of this dry, loose soil, which scattered during capping of the devices. Because vinyl chloride is a very volatile compound, average percent recovery values for this analyte serve as a good indicator of loss from the samplers by volatilization due to compromised seals. In this study, to reduce the possibility of particles scattering, the surface of the prairie soil samples in the En Core devices were patted down prior to capping.

**TABLE X1.8 Average Percent Recoveries of Low-Level<sup>A</sup> VOCs from Samples of Mountain Soil<sup>B</sup> Stored in 5-g En Core Samplers at -7 ± 1°C and -21 ± 2°C**

Storage Conditions:	-7 ± 1°C 14 days	48 h/4 ± 2°C 5 days/-7 ± 1°C	-21 ± 2°C 14 days	48 h/4 ± 2°C 5 days/-21 ± 2°C
VOCs				
MeCl <sub>2</sub>	88 <sup>C</sup> (3) <sup>D</sup>	96(7)	89(4)	95(9)
MTBE	93(3)	93(8)	101(2)	98(5)
1,1-Dichloroethane	98(3)	101(7)	89(4)	98(7)
CDCE	97(4)	95(7)	89(6)	97(12)
Chloroform	96(3)	104(5)	92(2)	98(8)
Benzene	92(7)	94(7)	85(2)	92(8)
TCE	95(6)	97(5)	88(3)	95(8)
Toluene	99(5)	100(5)	88(1)	97(6)
PCE	98(5)	102(4)	90(5)	97(6)
Ethyl benzene	96(5)	102(4)	91(2)	96(7)
o-Xylene	102(5)	104(5)	89(0.4)	96(6)

<sup>A</sup> Concentrations of the VOCs in the samples were ~100 µg/Kg, except for benzene concentrations at ~200 µg/Kg to ~400 µg/Kg, toluene concentrations at ~650 µg/Kg to ~900 µg/Kg, ethyl benzene concentrations at ~200 µg/Kg, and o-xylene concentrations at ~300 µg/Kg.

<sup>B</sup> The mountain soil is 75 % sand, 13 % silt, 12 % clay, 4.3 % organic material, and ~12 % moisture.

<sup>C</sup> Average percent recovery is based on mean concentration values determined for 5 time-zero samples and 5 stored samples minus outlier data points.

<sup>D</sup> The value in parentheses is the percent relative standard deviation of the concentration values in the stored samples. The percent relative standard deviation of the concentration values in the time-zero samples ranged from 2 to 10 %.

**TABLE X1.9 Average Percent Recoveries of Low-Level<sup>A</sup> VOCs  
from Samples of Mountain Soil<sup>B</sup> Stored in 25-g En Core  
Samplers at  $-7 \pm 1^\circ\text{C}$  and  $-21 \pm 2^\circ\text{C}$**

Storage Conditions:	$-7 \pm 1^\circ\text{C}$ 14 days	48 h/4 $\pm 2^\circ\text{C}$ 5 days/ $-7 \pm 1^\circ\text{C}$	$-21 \pm 2^\circ\text{C}$ 14 days	48 h/4 $\pm 2^\circ\text{C}$ 5 days/ $-21 \pm 2^\circ\text{C}$
VOCs				
MeCl <sub>2</sub>	94 <sup>C</sup> (3) <sup>D</sup>	98(2)	98(5)	96(3)
MTBE	105(4)	104(3)	94(1)	100(7)
1,1-Dichloroethane	96(2)	99(3)	98(5)	95(3)
CDCE	96(2)	97(2)	99(5)	96(3)
Chloroform	100(3)	99(2)	99(5)	97(2)
Benzene	93(4)	96(1)	99(3)	99(5)
TCE	98(3)	99(4)	96(3)	98(4)
Toluene	98(2)	100(2)	101(0.5)	97(3)
PCE	97(4)	101(2)	103(4)	102(3)
Ethyl benzene	97(3)	93(2)	98(0.4)	100(3)
o-Xylene	94(3)	96(3)	100(0.5)	100(2)

<sup>A</sup> Concentrations of the VOCs in the samples were ~100 µg/Kg, except for benzene concentrations at ~200 µg/Kg to ~400 µg/Kg, toluene concentrations at ~650 µg/Kg to ~900 µg/Kg, ethyl benzene concentrations at ~200 µg/Kg, and o-xylene concentrations at ~300 µg/Kg.

<sup>B</sup> The mountain soil is 75 % sand, 13 % silt, 12 % clay, 4.3 % organic material, and ~12 % moisture.

<sup>C</sup> Average percent recovery is based on mean concentration values determined for 5 time-zero samples and 5 stored samples minus outlier data points.

<sup>D</sup> The value in parentheses is the percent relative standard deviation of the concentration values in the stored samples. The percent relative standard deviation of the concentration values in the time-zero samples ranged from 4 to 6 %.

X1.1.9.2 As shown in Table X1.6 for the 5-g En Core sampler, all of the VOCs of interest have average percent recovery values equal to or greater than 90 % for storage of the spiked prairie soil samples at  $-12 \pm 2^\circ\text{C}$  for seven days, and ethyl benzene. For for storage at  $-12 \pm 2^\circ\text{C}$  for 14 days, except for CDCE, which has an average percent recovery of 88 % for storage at  $-12 \pm 2^\circ\text{C}$  for 14 days. The mean of the 24 average percent recovery values listed in Table X1.6 for the analytes of interest for these two storage conditions is 96 % recovery with a standard deviation of 4 % and a percent relative standard deviation of 4 %. In addition, all of the VOCs of interest have average percent recovery values of 80 % or greater for storage of the spiked prairie soil samples at  $4 \pm 2^\circ\text{C}$  for 48 h, for storage at  $4 \pm 2^\circ\text{C}$  for 48 h followed by storage at  $-12 \pm 2^\circ\text{C}$  for five days, and for storage at  $4 \pm 2^\circ\text{C}$  for 48 h followed by storage at  $-12 \pm 2^\circ\text{C}$  for 12 days, except for toluene, which has an average percent recovery of 74 % for storage at  $4 \pm 2^\circ\text{C}$  for 48 h followed by storage at  $-12 \pm 2^\circ\text{C}$  for 12 days. The mean of the 36 average percent recovery values listed in Table X1.6 for MTBE the analytes of interest for these three storage conditions is 990 %; recovery with a standard deviation of 6 % and a percent relative standard deviation of 7 %. For storage of the spiked prairie soil in the 5-g En Core sampler at  $4 \pm 2^\circ\text{C}$  for seven days, average percent recovery values for vinyl chloride and MTBE are 93 % and 101 %, respectively. In addition, for this storage condition, average percent recovery values range from 85 % to 88 % for 1,1-dichloroethane, chloroform, and MeCl<sub>2</sub>; from 71 % to 75 % for benzene, PCE, TCE, and CDCE; and from 57 % to 65 % for toluene, o-xylene, and ethyl benzene. For storage of the prairie soil samples at  $4 \pm 2^\circ\text{C}$  for 14 days, the average percent recovery value for MTBE is 99 %, while average percent recovery values for 1,1-dichloroethane, MeCl<sub>2</sub>, vinyl chloride, and chloroform range from 73 % to 77 %; average percent recovery values for benzene, PCE, CDCE, and TCE range from 53 % to 63 %; and average percent recovery values for toluene, ethyl benzene, and o-xylene range from 32 % to 37 %.

X1.1.9.3 As shown in Table X1.7 for the 25-g En Core sampler, all of the VOCs of interest have average percent recovery values greater than 90 % for storage of the spiked prairie soil samples at  $4 \pm 2^\circ\text{C}$  for 48 h, for storage at  $-12 \pm 2^\circ\text{C}$  for seven days, for storage at  $-12 \pm 2^\circ\text{C}$  for 14 days, for storage at  $4 \pm 2^\circ\text{C}$  for 48 h followed by storage at  $-12 \pm 2^\circ\text{C}$  for five days, and for storage at  $4 \pm 2^\circ\text{C}$  for 48 h followed by storage at  $-12 \pm 2^\circ\text{C}$  for 12 days. The only exceptions are toluene at 88 % recovery for storage at  $4 \pm 2^\circ\text{C}$  for 48 h, MeCl<sub>2</sub> ranging from 82 % to 89 % recovery for the last four storage conditions, and vinyl chloride at 88 % recovery for storage at  $-12 \pm 2^\circ\text{C}$  for 14 days. The mean of the 60 average percent recovery values listed in Table X1.7 for the analytes of interest for the five storage conditions discussed above is 96 % recovery with a standard deviation of 5 % and a percent relative standard deviation of 5 %. For storage at  $4 \pm 2^\circ\text{C}$  for seven days, the VOCs of interest have average percent recovery values that are greater than 80 %, except for o-xylene, toluene, ethyl benzene, and MeCl<sub>2</sub>, which have average percent recovery values ranging from 64 % to 73 %. For storage of the spiked prairie soil in the 25-g En Core sampler at  $4 \pm 2^\circ\text{C}$  for 14 days, the average percent recovery for MTBE is 94 %. In addition, for this storage condition, average percent recovery values range from 83 % to 89 % for 1,1-dichloroethane, vinyl chloride, and chloroform; from 71 % to 75 % for PCE, benzene, MeCl<sub>2</sub>, TCE, and CDCE; and from 54 % to 60 % for toluene, o-xylene, and ethyl benzene.

X1.1.9.4 As discussed in X1.1.9.1, in previous testing, lower average percent recovery values for the prairie soil were due to scattered particles compromising the seals of the En Core caps. The average percent recovery values for vinyl chloride from the spiked prairie soil samples in this study range from 76 % to 103 % for the 5-g 5-g sampler and 87 % to 105 % for the 25-g sampler for up to 14 days of storage (Table X1.6 and Table X1.7). These average percent recovery values show that the seals of the samplers

**TABLE X1.10 Summary of Average Percent Recoveries of Low-Level VOCs from Soil Samples Stored in the Disposable En Core Samplers**

Soil Type/ Sample Size	Average Percent Recovery	Storage Condition	Analytes of Interest		
River Bank, 5-g	90 % or Greater	4 ± 2°C for 48 h	All <sup>A</sup>		
		-12 ± 2°C for 7 days	All		
		4 ± 2°C for 48 h/-12 ± 2°C for 5 days	All		
	80 % or Greater	4 ± 2°C for 48 h/-12 ± 2°C for 12 days	All		
		4 ± 2°C for 7 days	All except MeCl <sub>2</sub> at 60 %		
		-12 ± 2°C for 14 days	All except MeCl <sub>2</sub> at 60 %		
River Bank, 25-g	90 % or Greater	4 ± 2°C for 48 h	All		
		4 ± 2°C for 7 days	All		
		-12 ± 2°C for 7 days	All		
	80 % or Greater	4 ± 2°C for 48 h/-12 ± 2°C for 5 days	All		
		4 ± 2°C for 14 days	All		
		4 ± 2°C for 48 h/-12 ± 2°C for 12 days	All except MeCl <sub>2</sub> at 72 %; MTBE at 74 %; chloroform at 77 %		
Mountain, 5-g	90 % or Greater	4 ± 2°C for 48 h/-7 ± 1°C for 5 days	All		
		4 ± 2°C for 48 h/-12 ± 2°C for 5 days	All		
		4 ± 2°C for 48 h/-21 ± 2°C for 5 days	All		
		-12 ± 2°C for 7 days	All		
		4 ± 2°C for 48 h/-12 ± 2°C for 12 days	All except MeCl <sub>2</sub> at 74 %		
		4 ± 2°C for 48 h	All <sup>A</sup>		
	80 % or Greater	-7 ± 1°C for 14 days	All		
		-12 ± 2°C for 14 days	All		
		-21 ± 2°C for 14 days	All		
		4 ± 2°C for 7 days	All except CDCE at 75 % and toluene at 74 %		
		Mountain, 25-g	90 % or Greater	4 ± 2°C for 48 h	All
				4 ± 2°C for 48 h/-7 ± 1°C for 5 days	All
4 ± 2°C for 48 h/-12 ± 2°C for 5 days	All				
4 ± 2°C for 48 h/-12 ± 2°C for 12 days	All				
4 ± 2°C for 48 h/-21 ± 2°C for 5 days	All				
-12 ± 2°C for 7 days	All				
80 % or Greater	4 ± 2°C for 7 days	-7 ± 1°C for 14 days	All		
		-12 ± 2°C for 14 days	All		
		-21 ± 2°C for 14 days	All		
		Prairie, 5-g	90 % or Greater	-12 ± 2°C for 7 days	All <sup>A,B</sup>
				4 ± 2°C for 48 h	All
			80 % or Greater	-12 ± 2°C for 14 days	All
4 ± 2°C for 48 h/-12 ± 2°C for 5 days	All				
4 ± 2°C for 48 h/-12 ± 2°C for 12 days	All except toluene at 74 %				
4 ± 2°C for 7 days	All				

**TABLE X1.10** *Continued*

Soil Type/ Sample Size	Average Percent Recovery	Storage Condition	Analytes of Interest
Prairie, 25-g	80 % or Greater	4 ± 2°C for 48 h	All <sup>A,B</sup>
		-12 ± 2°C for 7 days	All
		-12 ± 2°C for 14 days	All
		4 ± 2°C for 48 h/-12 ± 2°C for 5 days	All
		4 ± 2°C for 48 h/-12 ± 2°C for 12 days	All

<sup>A</sup> The analytes of interest are MeCl<sub>2</sub>, MTBE, 1,1-dichloroethane, CDCE, chloroform, benzene, TCE, toluene, PCE, ethyl benzene, and o-xylene.

<sup>B</sup> Vinyl chloride is an additional analyte of interest for testing using the prairie soil.

**TABLE X1.11 Summary of Average Percent Recoveries of Low-Level VOCs<sup>A</sup> from Mountain Soil<sup>B</sup> Stored in the Disposable En Core Samplers**

Sample Size	Average % Recovery	Storage Condition
5-g	90 % or Greater	4 ± 2°C for 48 h/-7 ± 1°C for 5 days
		4 ± 2°C for 48 h/-12 ± 2°C for 5 days
		4 ± 2°C for 48 h/-21 ± 2°C for 5 days
		-12 ± 2°C for 7 days
		-7 ± 1°C for 14 days
5-g	80 % or Greater	4 ± 2°C for 48 h
		-7 ± 1°C for 14 days
		-12 ± 2°C for 14 days
		-21 ± 2°C for 14 days
25-g	90 % or Greater	4 ± 2°C for 48 h
		4 ± 2°C for 48 h/-7 ± 1°C for 5 days
		4 ± 2°C for 48 h/-12 ± 2°C for 5 days
		4 ± 2°C for 48 h/-21 ± 2°C for 5 days
		4 ± 2°C for 48 h/-12 ± 2°C for 12 days
		-12 ± 2°C for 7 days
		-7 ± 1°C for 14 days
		-12 ± 2°C for 14 days
25-g	80 % or Greater	4 ± 2°C for 7 days
		4 ± 2°C for 14 days

<sup>A</sup> VOCs are MeCl<sub>2</sub>, MTBE, 1,1-dichloroethane, CDCE, chloroform, benzene, TCE, toluene, PCE, ethyl benzene, and o-xylene.

<sup>B</sup> The mountain soil is 75 % sand, 13 % silt, 12 % clay, 4.3 % organic material, and ~12 % moisture.

in this study were not compromised. If volatilization losses occurred because of compromised seals, these values would be expected to be much lower due to the volatility of vinyl chloride.

X1.1.10 A summary of the information obtained from this study is presented in Table X1.8. This table shows the storage conditions for which all or most of the analytes of interest have 90 % or greater or 80 % or greater average percent recovery for storage of the spiked soils in the 5-g and 25-g disposable En Core samplers.

X1.1.10.1 For the river bank and mountain soil samples stored in the 5-g En Core samplers, storage at 4 ± 2°C for 14 days is not listed in Table X1.8, because this storage condition gave average percent recovery values for 4 to 5 of the analytes of interest for both soils that are between 70 % and 80 % (Table X1.2 and Table X1.4). The exception to this is MeCl<sub>2</sub> in the 5-g river bank soil samples, which has an average percent recovery of 48 % for storage at 4 ± 2°C for 14 days. As discussed in X1.1.7.1, average percent recovery values for MeCl<sub>2</sub> in the 5-g river bank soil samples stored at 4 ± 2°C for seven days and at -12 ± 2°C for 14 days are also lower at 60 % recovery. In addition, it should also be noted that for the longer storage times, the 5-g samples of mountain and prairie soils and 25-g samples of river bank and prairie soils have average percent recovery values of approximately 70 % for MeCl<sub>2</sub>.

X1.1.10.2 For the prairie soil samples stored in the 5-g and 25-g En Core samplers, storage at 4 ± 2°C for seven days and 14 days is not listed in Table X1.8, because these storage conditions gave several average percent recovery values that are less than 80 % (Table X1.6 and Table X1.7). The lower average percent recovery values of approximately 30 % to 65 % observed for the prairie soil are not believed to be due to volatilization. As shown in Table X1.6 and Table X1.7, average percent recovery values for vinyl chloride are 92 % and 87 % for storage at 4 ± 2°C for seven days and 14 days, respectively, for the 25-g sampler; and 93 % and 76 % for storage at 4 ± 2°C for seven days and 14 days, respectively, for the 5-g sampler. If loss by volatilization was

occurring, these values would be expected to be much lower. chloride. Biodegradation also does not seem to be an explanation for the lower average percent recovery values for the prairie soil samples stored for 7 and 14 days at  $4 \pm 2^\circ\text{C}$ , because some of the compounds having lower average percent recovery values are chlorinated, and chlorinated compounds are resistant to biodegradation. In addition, the microbial activity of the river bank soil is slightly higher than that of the prairie soil (see X1.1.1), so if biodegradation is occurring, a similar trend would be expected for the river bank soil average percent recovery values. It appears that some sort of reaction between some of the analytes of interest (such as CDCE, benzene, TCE, toluene, PCE, ethyl benzene, and o-xylene) and the prairie soil may be occurring at  $4 \pm 2^\circ\text{C}$  that is hindered by the lower freezing temperature. The prairie soil has undergone additional characterizations; however, no information has been obtained to further explain the data.

X1.2 A second study was performed to evaluate the performance of the 5- and 25-g En Core samplers to store the mountain soil (see X1.1.1) used in the study described in X1.1 at temperatures of  $-7 \pm 1^\circ\text{C}$  and  $-21 \pm 2^\circ\text{C}$ . The 5-g devices used in this study were from lot number K113224, and the 25-g devices were from lot number K113206. The VOCs used in the study are the same as those listed in X1.1.2, and the storage conditions used in the study are  $-7 \pm 1^\circ\text{C}$  for 14 days,  $-21 \pm 2^\circ\text{C}$  for 14 days,  $4 \pm 2^\circ\text{C}$  for 48 h followed by storage for 5 days at  $-7 \pm 1^\circ\text{C}$ , and  $4 \pm 2^\circ\text{C}$  for 48 h followed by storage for 5 days at  $-21 \pm 2^\circ\text{C}$ .

X1.2.1 This second study was performed as described in sections X1.1.3 through X1.1.5. As in the previous study, the samples were spiked to give an approximate concentration of  $100 \mu\text{g}/\text{Kg}$  of each analyte of interest in the samples, with the exception of benzene, toluene, ethyl benzene, and o-xylene. Because of their presence in the gasoline-saturated water, the concentrations of benzene were approximately  $200 \mu\text{g}/\text{Kg}$  to approximately  $400 \mu\text{g}/\text{Kg}$ , and the concentrations of toluene were approximately  $650 \mu\text{g}/\text{Kg}$  to approximately  $900 \mu\text{g}/\text{Kg}$ . Additional o-xylene and ethyl benzene were also added to the spiking solution by the gasoline-saturated water. This resulted in o-xylene and ethyl benzene concentrations in the spiked soil samples at approximately  $300 \mu\text{g}/\text{Kg}$  and approximately  $200 \mu\text{g}/\text{Kg}$ , respectively.

X1.2.2 The temperatures in the freezers used to store the samples at  $-7$  and  $-21^\circ\text{C}$  were monitored using mini temperature data loggers.

X1.2.3 As for the data generated in the study described in X1.1, the data generated by this testing are specific to the experimental design of the study. They give information on the performance of the En Core samplers for storing soil samples collected from loose soil, spiked with a gasoline-saturated water solution containing selected analytes of interest, and then stored under specific storage conditions. The data generated by this testing are specific to the soil used in the study, the analytes of interest, the analyte concentrations, and the storage conditions that were evaluated. For other soil types, analytes, analyte concentrations, and storage conditions, these data may not apply.

X1.2.4 The average percent recoveries of the VOCs of interest from samples of the mountain soil stored in the 5-g En Core samplers are shown in Table X1.8; and the average percent recoveries of the VOCs of interest from the samples of the mountain soil stored in the 25-g En Core samplers are shown in Table X1.9. In each of these tables, the percent relative standard deviation of the concentration values in the stored samples is given in parentheses next to the corresponding average percent recovery value. The percent relative standard deviation of the concentration values in the time-zero samples is given in a footnote to each of the tables.

X1.2.4.1 As shown in Table X1.8 for the 5-g sampler, all of the VOCs of interest have average percent recovery values that are greater than 90 % for storage at  $4 \pm 2^\circ\text{C}$  for 48 h followed by storage at  $-7 \pm 1^\circ\text{C}$  for 5 days and for storage at  $4 \pm 2^\circ\text{C}$  for 48 h followed by storage at  $-21 \pm 2^\circ\text{C}$  for 5 days. For storage at  $-7 \pm 1^\circ\text{C}$  for 14 days and for storage at  $-21 \pm 2^\circ\text{C}$  for 14 days, the average percent recovery values for all of the analytes of interest are greater than 80 %.

X1.2.4.2 As shown in Table X1.9 for the 25-g sampler, all of the VOCs of interest have average percent recovery values that are greater than 90 % for storage at  $4 \pm 2^\circ\text{C}$  for 48 h followed by storage at  $-7 \pm 1^\circ\text{C}$  for 5 days, for storage at  $-7 \pm 1^\circ\text{C}$  for 14 days, for storage at  $4 \pm 2^\circ\text{C}$  for 48 h followed by storage at  $-21 \pm 2^\circ\text{C}$  for 5 days, and for storage at  $-21 \pm 2^\circ\text{C}$  for 14 days.

X1.3 A summary of the information obtained from the studies described in X1.1 and X1.2 is presented in Table X1.10. This table shows the storage conditions for which all or most of the analytes of interest have 90 % or greater or 80 % or greater average percent recovery for storage of the spiked soil in the 5-g and 25-g disposable En Core samplers. In addition, the data generated in the studies described in X1.1 and X1.2 for the mountain soil can be summarized as shown in Table X1.11. This table shows the storage conditions for the spiked mountain soil samples for which the average percent recovery values are 90 % or greater or 80 % or greater for the analytes of interest.

## X2. PERFORMANCE OF THE 25-GRAM EN CORE SAMPLER TO STORE SOIL SAMPLES FOR VOC CHARACTERIZATION USING EPA METHOD 1311

X2.1 A study was conducted to evaluate the performance of the 25-g En Core sampler to store a soil spiked with EPA Method 1311 volatile analytes for subsequent characterization using EPA Method 1311. The En Core samplers used in this study were manufactured in July 2000. The 25-g devices that were used represent lot number K110187. The manufacturer can be contacted for information on this lot number.

X2.1.1 The soil used in the study was collected from a mountainous region in southeastern Wyoming. The soil contains 75 % sand, 13 % silt, 12 % clay, 4.3 % organic material, and approximately 12 % moisture, and has a dehydrogenase (microbial) activity of 11 mg total product formed (TPF)/g/24 h.

X2.1.2 In the study, data were generated for 22 of the 25 Method 1311 volatile analytes. Data could not be generated for methanol because it is the extraction solvent that was used for VOC analysis (see X2.1.3). In addition, data could not be generated for isobutanol and n-butanol because of the difficulty in purging these compounds from the methanol-water mixture during analysis and because of the type of trap used for the purge-and-trap technique. The VOCs for which data were generated in the study are listed in Table X2.1.

X2.1.3 In this study, soil samples were collected in the 25-g En Core samplers from a large container of loose soil and then spiked with one of the spiking solutions described in X2.1.4. The spiking solution was injected into the middle of the soil plug in the sampler, and the sampler was immediately capped. After all samples were spiked and capped, five random samples for each spiking solution were extruded into methanol for analysis to give time-zero concentrations of the analytes of interest. The remaining samples were stored under the storage conditions shown in Table X2.2. As shown in this table, freezing at  $-12 \pm 2^\circ\text{C}$  was evaluated as a storage condition. A frozen sample would not be appropriate for extraction in the zero-headspace extractor as specified in Method 1311. However, if the option that is given in Method 1311 for total analysis of the sample is performed, freezing may be a means of sample preservation during storage (see 3.2). For each spiking solution, five samples were stored under each storage condition. Storage temperatures were monitored to make sure they were at the specified temperature. After the samples were held for the appropriate times, they were extruded into methanol for extraction and analysis. The methanol extracts of the samples were analyzed using EPA Methods 8260B and 5030B.

X2.1.4 A single spiking solution containing all 22 compounds listed in Table X2.1 could act as a preservative. Therefore, the compounds were divided into three spiking solutions containing a smaller number of analytes. The first spiking solution contained vinyl chloride, carbon disulfide, chlorobenzene, 1,2-dichloroethane, 1,1-dichloroethylene, PCE, carbon tetrachloride, and chloroform. The second spiking solution contained trichlorofluoromethane, Freon 113, 1,1,1-trichloroethane, ethyl benzene, TCE, total xylenes, ethyl ether, and methylene chloride. The third spiking solution contained acetone, ethyl acetate, MEK, and MIBK. Benzene and toluene were present in all three spiking solutions. The spiking solutions were prepared by injecting a methanol solution containing a mixture of the specific analytes into gasoline-saturated water. Benzene and toluene were not present in the methanol solution, but came totally from the gasoline used to prepare the gasoline-saturated water. Spiking the soil samples in the 25-g En Core devices with 0.5 mL of the first or second spiking solution gave an approximate concentration of 100  $\mu\text{g}/\text{Kg}$  of each analyte in the soil, except for benzene, toluene, and total xylenes. The spiked soil samples contained approximately 300  $\mu\text{g}/\text{Kg}$  of

**TABLE X2.1 VOCs Used in the Study to Evaluate Performance of the 25-g En Core Sampler to Store Samples for EPA Method 1311**

Acetone
Benzene
Carbon disulfide
Carbon tetrachloride
Chlorobenzene
Chloroform
1,2-Dichloroethane
1,1-Dichloroethylene
Ethyl acetate
Ethyl benzene
Ethyl ether
Methylene chloride
Methyl ethyl ketone (MEK)
Methyl isobutyl ketone (MIBK)
Tetrachloroethylene (PCE)
Toluene
1,1,1-Trichloroethane
Trichloroethylene (TCE)
Trichlorofluoromethane
1,1,2-Trichloro-1,2,2-trifluoroethane (Freon 113)
Vinyl chloride
Total Xylenes

**TABLE X2.2 Storage Conditions for Testing the 25-g En Core Sampler to Store Samples for EPA Method 1311**

Storage Times/ Conditions	No Storage	48 h at 4 ± 2°C in a cooler/ 12 Days at 4 ± 2°C in a refrigerator	14 days in a freezer at -12 ± 2°C	48 h at 4 ± 2°C in a cooler/ 12 days at -12 ± 2°C in a freezer
Storage Times/ Conditions	No Storage	48 h at 4 ± 2°C in a cooler/ 12 Days at 4 ± 2°C in a refrigerator	14 days in a freezer at -12 ± 2°C	48 h at 4 ± 2°C in a cooler/ 12 days at -12 ± 2°C in a freezer
Time-zero	5 samples			
14 days		5 samples		
14 days			5 samples	
14 days				5 samples

benzene and approximately 1,000 µg/Kg of toluene. Additional xylene and ethyl benzene were added to the second spiking solution by the gasoline-saturated water. This resulted in xylene and ethyl benzene concentrations in the spiked soil at approximately 500 µg/Kg and approximately 100 µg/Kg, respectively. The third spiking solution was prepared as described above; however, because of the difficulty in purging acetone, ethyl acetate, MEK, and MIBK from the water-methanol mixture during analysis of the methanol extract of the soil, the spiking solution was prepared and the samples were spiked to give higher concentrations of these analytes in the soil. Their concentrations in the spiked soil were as follows: acetone at approximately 2,000 µg/Kg, MEK at approximately 4,000 µg/Kg, ethyl acetate at approximately 1,000 µg/Kg, and MIBK at approximately 4,000 µg/Kg.

X2.1.5 To evaluate the data, the mean concentrations of the analytes in the stored samples were compared to their mean concentrations in the time-zero samples by calculating average percent recovery. Before average percent recovery was calculated, the data sets were evaluated for outlier data points as described in Practice D 2777.

X2.1.6 The data generated by this testing are specific to the experimental design of the study. The data give information on the performance of the 25-g En Core sampler for storing soil samples collected from loose soil, spiked with a gasoline-saturated water solution containing EPA Method 1311 volatile organic analytes, and then stored under various storage conditions for 14 days. The data generated by this testing are also specific to the soil used in the study, the analytes used, the analyte concentrations, and the storage conditions that were evaluated. For other matrices and soil types, analytes, analyte concentrations, and storage conditions, these data may not apply.

X2.1.7 The average percent recoveries of Method 1311 volatile analytes from the spiked mountain soil samples stored in the 25-g disposable En Core samplers are shown in Table X2.3. In this table, the percent relative standard deviation of the concentration values in the stored samples is given in parentheses next to the corresponding average percent recovery value. The percent relative standard deviation of the concentration values in the time-zero samples is given in a footnote to the table.

X2.1.7.1 As shown in Table X2.3, carbon disulfide and ethyl acetate have very low recoveries from the stored samples for all three storage conditions. Based on the data for the other compounds listed in Table X2.3, it can be assumed that this is not due

**TABLE X2.3 Average Percent Recoveries of Method 1311 Volatile Analytes from Mountain Soil Samples Stored in 25-g Disposable En Core Samplers**

Storage Conditions:	48 h at 4 ± 2°C in cooler/ 12 days at 4 ± 2°C in refrigerator	48 h at 4 ± 2°C in cooler/ 12 days at -12 ± 2°C in freezer	14 days in freezer at -12 ± 2°C
<b>VOCs</b>			
Acetone	101 <sup>A</sup> (8) <sup>B</sup>	98 (3)	99 (9)
Benzene	98 (3)	103 (3)	103 (5)
Benzene in duplicate sample	100 (2)	101 (0.5)	102 (4)
Carbon disulfide	8 (10)	29 (17)	55 (7)
Carbon tetrachloride	97 (2)	98 (4)	102 (5)
Chlorobenzene	96 (2)	99 (2)	97 (3)
Chloroform	94 (1)	102 (3)	100 (2)
1,2-Dichloroethane	75 (2)	99 (3)	100 (4)
1,1-Dichloroethylene	71 (13)	88 (4)	95 (6)
Ethyl acetate	< 27	< 27	< 27
Ethyl benzene	102 (2)	99 (2)	100 (3)
Ethyl ether	97 (6)	98 (1)	93 (4)
Methylene chloride	98 (5)	100 (2)	104 (8)
MEK	96 (9)	95 (4)	95 (8)
MIBK	103 (3)	99 (2)	99 (7)
PCE	98 (3)	99 (1)	103 (1)
Toluene	94 (2)	99 (4)	99 (3)
Toluene in duplicate sample	95 (2)	99 (2)	99 (3)
1,1,1-Trichloroethane	94 (5)	96 (2)	97 (2)
TCE	101 (2)	101 (1)	105 (5)
Trichlorofluoromethane	87 (5)	87 (3)	91 (7)
Freon 113	85 (7)	87 (5)	93 (3)
Vinyl chloride	83 (16)	85 (8)	92 (13)
Total Xylenes	100 (1)	100 (2)	101 (3)

<sup>A</sup>Average percent recovery is based on mean concentration values determined for five time-zero samples and five stored samples minus outlier data points.

<sup>B</sup>The value in parentheses is the percent relative standard deviation of the concentration values in the stored samples. The percent relative standard deviation of the concentration values in the time-zero samples ranged from 1 % to 6 % for all of the analytes, except for ethyl ether at 11 % and ethyl acetate at 37 %.

to loss of these compounds from the samples, but most likely due to a reaction with the soil matrix.

X2.1.7.2 Average percent recovery values for the compounds listed in Table X2.3, excluding carbon disulfide and ethyl acetate, range from 83 % to 103 % for storage at  $4 \pm 2^\circ\text{C}$  for 14 days, except for 1,2-dichloroethane at 75 % recovery and 1,1-dichloroethylene at 71 % recovery; average percent recovery values for the compounds listed in Table X2.3, excluding carbon disulfide and ethyl acetate, for storage at  $4 \pm 2^\circ\text{C}$  for 48 h and then 12 days at  $-12 \pm 2^\circ\text{C}$  range from 85 % to 103 %; and average percent recovery values for the compounds listed in Table X2.3, excluding carbon disulfide and ethyl acetate, range from 91 % to 105 % for storage at  $-12 \pm 2^\circ\text{C}$  for 14 days. Percent recovery values for benzene and toluene in the samples spiked with the first and second spiking solutions (see X2.1.4) are listed in Table X2.3 (benzene, benzene in duplicate sample, toluene, toluene in duplicate sample). As shown, there is close agreement between average percent recovery values for the duplicates for the three storage conditions.

X2.1.7.3 For most of the compounds listed in Table X2.3, percent relative standard deviations of the concentration values in the stored samples (values in parentheses) are less than 10 %, showing good precision of the performance of the En Core samplers to store the spiked soil samples.

*ASTM International takes no position respecting the validity of any patent rights asserted in connection with any item mentioned in this standard. Users of this standard are expressly advised that determination of the validity of any such patent rights, and the risk of infringement of such rights, are entirely their own responsibility.*

*This standard is subject to revision at any time by the responsible technical committee and must be reviewed every five years and if not revised, either reapproved or withdrawn. Your comments are invited either for revision of this standard or for additional standards and should be addressed to ASTM International Headquarters. Your comments will receive careful consideration at a meeting of the responsible technical committee, which you may attend. If you feel that your comments have not received a fair hearing you should make your views known to the ASTM Committee on Standards, at the address shown below.*

*This standard is copyrighted by ASTM International, 100 Barr Harbor Drive, PO Box C700, West Conshohocken, PA 19428-2959, United States. Individual reprints (single or multiple copies) of this standard may be obtained by contacting ASTM at the above address or at 610-832-9585 (phone), 610-832-9555 (fax), or service@astm.org (e-mail); or through the ASTM website (www.astm.org).*