



Designation: **F 2033 – 00a**

Standard Specification for Total Hip Joint Prosthesis and Hip Endoprosthesis Bearing Surfaces Made of Metallic, Ceramic, and Polymeric Materials¹

This standard is issued under the fixed designation F 2033; the number immediately following the designation indicates the year of original adoption or, in the case of revision, the year of last revision. A number in parentheses indicates the year of last reapproval. A superscript epsilon (ϵ) indicates an editorial change since the last revision or reapproval.

1. Scope

1.1 This specification covers the requirements for the mating bearing surfaces of total hip prostheses and hip endoprostheses. More specifically, this specification covers hip joint replacement of the ball-and-socket configuration. This specification does not address the tolerance match between the mating bearing surfaces.

1.2 This specification covers the sphericity, surface finish requirements, and dimensional tolerances for the spherical articulating metallic or ceramic femoral heads of total hip joint prostheses.

1.3 This specification covers the sphericity, surface finish requirements, and dimensional tolerances for the spherical concave mating surface of metallic and ceramic acetabular components, including the inner polymeric bearing surface of bipolar heads, and the surface finish requirements and dimensional tolerances for the spherical concave mating surface of polymeric acetabular components.

1.4 This specification covers the sphericity and surface finish requirements for the spherical metallic or ceramic femoral heads of hip endoprostheses, and the outer bearing surface of bipolar heads.

1.5 The values stated in SI units are to be regarded as the standard.

1.6 This specification is intended for standard practice regarding the design of total hip joint bearing surfaces. Additionally, the tolerances imposed on the polymeric portion of the bearing surface are intentionally large due to temperature-induced size changes and other manufacturing concerns. Some manufacturing methods or designs may intentionally reduce the diameter of the polymeric bearing to more closely mate with the diameter of the head.

2. Referenced Documents

2.1 *ASTM Standards:*

¹ This specification is under the jurisdiction of ASTM Committee F~~04~~ F04 on Medical and Surgical Materials and Devices and is the direct responsibility of Subcommittee F04.22 on Arthroplasty.

Current edition approved ~~May~~ Nov. 10, 2000. Published ~~A~~ January 2001.

Originally published as F2033-00. Last previous edition F2033-00.

F 370 Specification for Proximal Femoral Endoprotheses²

2.2 *ISO Documents:*

ISO 468 Surface Roughness-Parameters, Their Values, and General Rules for Specifying Requirements³

ISO 4287/1 Surface Roughness - Terminology³

ISO 4291 Methods for the Assessment of Departure from Roundness, Measurement of Variations, and Radius³

ISO 5436 Surface Texture of Products – Calibration Specimens for Stylus Instruments³

ISO 6318-1985 Measurement of Roundness—Terms, Definitions, and Parameters of Roundness (Equivalent to BS 3730 Part 1: 1987)³

ISO 7206-1 Implants for Surgery—Partial and Total Hip Joint Prosthesis—Part I: Classification, Designation of Dimensions, and Requirements³

ISO 7206-2 Implants for Surgery—Partial and Total Hip Joint Prosthesis—Part II: Bearing Surfaces Made of Metallic and Plastics Materials³

2.3 *ANSI/ASME Document:*

ANSI/ASME B46.1-1995 Surface Texture³

3. Dimensions and Characteristics

3.1 *Definition:*

3.1.1 *Pole of the Articulating Surface*—The pole of an articulating surface is defined by a point at the intercept of the revolution axis of the component and the spherical articulation surface.

3.1.2 *Equator of the Articulating Surface*—The equator of the articulating surface is the circle normal to the revolution axis of the component, the center of which is the center of the spherical articulating surface.

3.1.3 *Cutoff Length*—The cutoff length defines the maximal value of the mean twist of profile irregularities that shall be considered in the roughness measurement, that is, with a cutoff length of 0.8 mm, the profile irregularities with a mean twist higher than 0.8 mm shall not be considered.

3.1.3.1 Precise definitions of roughness parameters, cutoff length, and roundness are given in ISO 4287/1, ISO 5436, ISO 4291, and ISO 6318:1985.

3.1.4 *Stylus Tip*—The stylus tip is the tip of the measuring device (diamond or Focodyn) which measures the surface roughness. A stylus has a pseudoconical shape with a hemispherical tip. Typical sizes for the tip are 2, 5, or 10 μm . The selection of the stylus tip is dependent on the range of the roughness measured.

3.2 *Total Hip Joint Prosthesis:*

3.2.1 *Femoral Head:*

3.2.1.1 When inspected visually under 5-diopter magnification, the bearing surface shall be free from particles, scratches, and score marks other than those arising from the finishing process.

3.2.1.2 *Sphericity*—The metal or ceramic spherical bearing surface of a femoral hip component shall have a departure from roundness of not greater than 10 μm (390 $\mu\text{in.}$) This shall be measured as ΔZ_z in accordance with the Minimum Zone Center Method in ISO 4291 measuring the roundness in more than two planes, or by the method in Appendix X2. For metallic femoral heads used in conjunction with metallic acetabular components and ceramic femoral heads used in conjunction with ceramic acetabular components, the departure from roundness values shall not be greater than 5 μm (200 $\mu\text{in.}$).

3.2.1.3 *Surface Finish*—When measured in accordance with ISO 468 or ANSI/ASME B46.1, the spherical bearing surface of a femoral component shall have a R_a value not greater than 0.05 μm (2 $\mu\text{in.}$). The measurements shall be taken at the location of the pole and 30° from the pole.

3.2.1.4 *Dimensional Tolerances*—The spherical bearing surface shall have a diameter equal to the nominal diameter with a tolerance of +0.0, -0.2 mm (+0.000, -0.008 in.)

3.2.1.5 For metallic femoral heads used in conjunction with metallic acetabular components, or ceramic femoral heads used in conjunction with ceramic acetabular components, the manufacturer should report the diameters and tolerances of the heads, if different from the tolerance values in 3.2.1.4.

3.2.2 *Polymeric Acetabular Components:*

3.2.2.1 When inspected visually under 5-diopter magnification, the bearing surface shall be free from particles, scratches, and score marks other than those arising from the finishing process.

3.2.2.2 *Surface Finish*—When measured in accordance ISO 468 or ANSI/ASME B46.1, the spherical bearing surface of the acetabular component shall have a R_a value not greater than 2 μm (80 $\mu\text{in.}$)

3.2.2.3 *Dimensional Tolerances*—The spherical socket shall have a diameter equal to the nominal diameter within a tolerance of +0.3, -0.0 mm (+0.012, -0.0 in) at a temperature of 20 \pm 2°C (68 \pm 4°F). The socket should be oversized to the nominal within the given tolerance range.

3.2.3 *Metallic Acetabular Components:*

² Annual Book of ASTM Standards, Vol 13.01.

³ Available from American National Standards Institute, 11 W. 42nd St., 13th Floor, New York, NY 10036.

3.2.3.1 When inspected visually under 5-diopter magnification, the bearing surface shall be free from particles, scratches, and score marks other than those arising from the finishing process.

3.2.3.2 *Sphericity*—The spherical bearing surface of the metal acetabular component shall have a departure from roundness of not greater than 5 μm (200 $\mu\text{in.}$). This shall be measured as ΔZ_z in accordance with the Minimum Zone Center Method in ISO 4291 measuring the roundness in more than two places, or as determined by the method in Appendix X2.

3.2.3.3 *Surface Finish*—When measured in accordance with ISO 468 or ANSI/ASME B46.1, the spherical bearing surface of the acetabular component shall have a R_a value of not greater than 0.05 μm (2 $\mu\text{in.}$).

3.2.3.4 Under maximum material condition (MMC), the articulating part of the socket and metallic head, there should be clearance and both components never produce an interference fit.

3.2.3.5 Metallic heads and sockets from different manufacturers should not be mated because the combinations of tolerances within the family, surface finish, and configuration for the different manufacturers may not have been validated through appropriate testing.

3.2.4 *Ceramic Acetabular Components:*

3.2.4.1 When inspected visually under 5-diopter magnification, the bearing surface shall be free from particles, scratches, and score marks other than those arising from the finishing process.

3.2.4.2 *Sphericity*—The ceramic spherical bearing surface of a acetabular component shall have a departure from roundness of not greater than 5 μm (200 $\mu\text{in.}$). This shall be measured as ΔZ_z in accordance with the Minimum Zone Center Method in ISO 4291 measuring the roundness in more than two planes, or as determined by the method in Appendix X2.

3.2.4.3 *Surface Finish*—When measured in accordance with ISO 468 or ANSI/ASME B46.1, the spherical bearing surface of the acetabular component shall have a R_a value of not greater than 0.05 μm (2 $\mu\text{in.}$).

3.2.4.4 Under MMC, the articulating part of the socket and ceramic head, there should be clearance and both components never produce an interference fit.

3.2.4.5 Ceramic heads and sockets from different manufacturers should not be mated because the combinations of tolerances within the family, surface finish, and configuration for the different manufacturers may not have been validated through appropriate testing.

3.3 *Hip Endoprostheses*, in accordance with Specification F 370:

3.3.1 *Sphericity*—The metal or ceramic spherical bearing surface of a femoral hip component shall have a departure from roundness of not greater than 100 μm (3940 $\mu\text{in.}$). This shall be measured as ΔZ_z in accordance with the Minimum Zone Center Method in ISO 4291 measuring the roundness in more than two planes, or as determined by the method in Appendix X2.

3.3.2 *Surface Finish*—When measured in accordance with ISO 468 or ANSI/ASME B46.1, the spherical bearing surface of femoral endoprostheses components shall have a R_a value not greater than 0.5 μm (20 $\mu\text{in.}$).

3.4 *Bipolar Heads:*

3.4.1 *Inner Surface*—The inner surface of bipolar heads shall comply with the specification in 3.1.2.

3.4.2 *Outer Surface*—The outer surface of bipolar heads shall comply with the specifications in 3.2.

4. Report

4.1 When reporting results of tests to evaluate total hip joint and hip endoprosthesis components for conformance to this specification, deviations from the specified stylus tip radius, cutoff length of the measuring instrument, and locations of the measurements shall be included.

5. Keywords

5.1 acetabular cup; arthroplasty; femoral head; roundness

APPENDIXES

(Nonmandatory Information)

X1. RATIONALE

NOTE X1.1—Individual designs may vary from this if there is good engineering rationale supporting the design modifications.

X1.1 The primary reasons for this specification are:

X1.1.1 To define common parameters for characterization of the roundness and surface finish requirements, and establish dimensional relationships for articulating metallic and ceramic femoral heads of total hip joint prosthesis.

X1.1.2 To characterize the surface finish requirements and dimensional relationships for the spherical concave mating surfaces of articulating components, such that the concave surfaces are always oversized compared to the mating femoral head.

X1.1.3 To characterize the roundness and surface finish requirements for the spherical femoral heads of hip endoprosthesis, the tolerance requirements being specified in Specification F 370

X1.1.4 To provide for interchangeability of femoral heads and acetabular cups.
 X1.1.5 To provide for minimum dimensions based on acceptable clinical usage.

X1.2 This specification is based in ISO 7206-2.

X1.3 Tolerance mismatches between mating articulating surfaces are part of the design of the device. These mismatches tend to vary with design concepts and manufacturing philosophies. Consequently, they are not addressed in this specification.

X1.4 The specification of standardized nominal dimensions for femoral head diameters or acetabular cup inside diameters is beyond the scope of this specification.

X1.5 Roundness measured in more than one plane provides a measure of sphericity. The MZC method of measuring roundness is much more precise than the appended method of measuring sphericity. The MZC method of measuring roundness takes a large number of points around a section of the sphere and determines the roundness of that circle. By checking two or more nonparallel sections, sphericity can be assumed to be the maximum out-of-roundness. Where the appended method only uses 25 points over the whole surface and is allowed to ignore the pole as long as it is a negative feature. The appended method is not a preferred method to determine the sphericity of a femoral head and should only be used if no other method is available to measure roundness.

X1.6 The specification of standardized dimensions for femoral head diameters or acetabular socket diameters is beyond the scope of this specification.

X2. DETERMINATION OF THE GEOMETRIC PROPERTIES OF THE FEMORAL HEAD AND ACETABULAR COMPONENTS

X2.1 Femoral Head:

X2.1.1 Using a three-dimensional measuring machine, with a measuring stylus in accordance with the device to be tested, 25 points situated as shown in Fig. X2.1 shall be measured. The 25 points shall consist of 8 points spaced equally about the circumference of the planes AA, BB, and CC, and a measurement at the pole. If the articulating surface extends below the equator, then AA shall be coincident with the equator of the femoral ball. Otherwise, AA shall be a diametral plane, located within 1 mm of the border or the articulating surface. The angles a, b, and c are measured relative to the neck axis and shall be as follows:

$$c = a/3$$

$$b = 2a/3$$

NOTE X2.1—If AA is coincident with the equator, a = 90°, b = 60°, and c = 30°.

X2.1.2 Determine the average diameter by the least squares method as well as the coordinates of the center O of the sphere of average diameter.

X2.1.3 Determine the departure from roundness as the difference between the smaller and the larger measured distances from this O center.

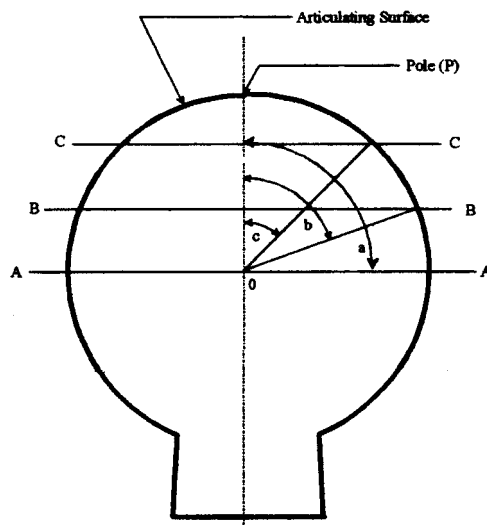

FIG. X2.1 Locations of Measurement Points on the Surface of the Femoral Head

X2.1.4 Determine the measured imprecision due to both the machine and the method. Imprecision on the average diameter shall include the factor departure from roundness.

X2.1.5 The same measures may be repeated on 24 points, excluding the polar point, in order to determine whether the polar point is in a depression (and thus does not significantly affect function) or is projecting.

X2.2 Acetabular Component:

X2.2.1 Using a three-dimensional measuring machine, with a measuring stylus in accordance with the device to be tested, 25 points situated as shown in Fig. X2.2 shall be measured. The 25 points shall consist of 8 points spaced equally about the circumference of the planes AA, BB, and CC, and a measurement at the pole. If the articulating surface extends below the equator, then AA shall be coincident with the equator of the femoral ball. Otherwise, AA shall be a diametral plane, located within 1 mm of border or the articulating surface. The angles a, b, and c are measured relative to the neck axis and shall be as follows:

$$c = a/3$$

$$b = 2a/3$$

See Note X2.1.

X2.2.2 Determine the average diameter by the least squares method as well as the coordinates of the center O of the sphere of average diameter.

X2.2.3 Determine the departure from roundness as the difference between the smaller and the larger measured distances from this O center.

X2.2.4 Determine the measured imprecision due to both the machine and the method. Imprecision on the average diameter shall include the factor departure from roundness.

X3. ROUGHNESS MEASURES

X3.1 The roughness measurement R_a is used in this specification because it is a widely recognized parameter of roughness; it has a long history of use in literature regarding prosthetic joints; and it is specified in ISO 7606-2 (Rev 1996). A number of other surface roughness parameters may be calculated such as R_z , R_p , R_{max} , R_{mv} , R_p , R_{pm} , and others. However, the complex, three-dimensional topography of the surface of a femoral ball cannot be completely described by any single numerical parameter, and the relative influence of these roughness parameters on the friction and wear of the bearing surfaces has not yet been established. For this reason, it is recommended that a full characterization of the roughness characteristics of a given ball include several roughness parameters, as well as qualitative imaging, such as scanning electron microscopy.

ASTM International takes no position respecting the validity of any patent rights asserted in connection with any item mentioned in this standard. Users of this standard are expressly advised that determination of the validity of any such patent rights, and the risk of infringement of such rights, are entirely their own responsibility.

This standard is subject to revision at any time by the responsible technical committee and must be reviewed every five years and if not revised, either reapproved or withdrawn. Your comments are invited either for revision of this standard or for additional standards and should be addressed to ASTM International Headquarters. Your comments will receive careful consideration at a meeting of the responsible technical committee, which you may attend. If you feel that your comments have not received a fair hearing you should make your views known to the ASTM Committee on Standards, at the address shown below.

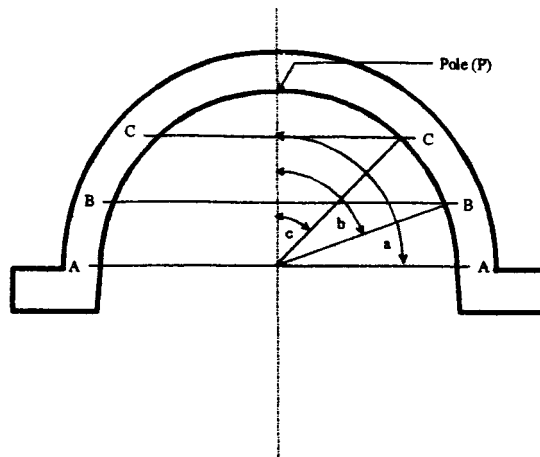

FIG. X2.2 Location of Measurement Points on the Acetabulum

This standard is copyrighted by ASTM International, 100 Barr Harbor Drive, PO Box C700, West Conshohocken, PA 19428-2959, United States. Individual reprints (single or multiple copies) of this standard may be obtained by contacting ASTM at the above address or at 610-832-9585 (phone), 610-832-9555 (fax), or service@astm.org (e-mail); or through the ASTM website (www.astm.org).