



Standard Specification for ASTM Liquid-in-Glass Thermometers¹

This standard is issued under the fixed designation E 1; the number immediately following the designation indicates the year of original adoption or, in the case of revision, the year of last revision. A number in parentheses indicates the year of last reappraisal. A superscript epsilon (ϵ) indicates an editorial change since the last revision or reappraisal.

This standard has been approved for use by agencies of the Department of Defense.

1. Scope

1.1 This specification covers liquid-in-glass thermometers graduated in degrees Celsius (~~centigrade~~) or ~~Fahrenheit~~ degrees ~~which Fahrenheit that~~ are frequently ~~specified~~ identified and used in methods under the jurisdiction of the various technical committees within ASTM. The various thermometers ~~covered~~ specified are listed in Table 1. The ~~designation~~ inclusion of an IP number in Table 1 indicates, where appearing, that the thermometer specification has been jointly agreed upon by the British Institute of Petroleum (IP) and ASTM.

1.2 This specification also covers adjustable-range enclosed-scale thermometers, graduated in ~~Celsius (centigrade) degrees,~~ degrees Celsius, which are ~~specified used in methods of ASTM.~~ ASTM methods.

1.3 The enclosed-scale thermometers are commonly called Beckmann thermometers. They are suitable for measuring small temperature differences not exceeding 6 °C within a larger range of temperature. The thermometers are unsuitable for measuring Celsius- or kelvin-scale temperatures unless they have been compared with standard instruments immediately before use.

1.4 An alphabetic list of the ASTM Thermometers included in this standard is given in Table 2.

1.5 A list of ASTM Thermometers is given in Table 3 to facilitate selection according to temperature range, immersion, and scale-error requirements.

NOTE 1—For a listing of thermometers recommended for general laboratory use, the Scientific Apparatus Makers Association: Specifications for

¹ This specification is under the jurisdiction of ASTM Committee E20 on Temperature Measurement and is the direct responsibility of Subcommittee E20.05 on Liquid-in-Glass Thermometers and Hydrometers.

Current edition approved ~~May 10,~~ Nov. 1, 2003. Published ~~June~~ December 2003. Originally approved in 1939. Last previous edition approved in 2003³ as E 1–04³.

General Purpose Glass Laboratory Thermometers may be consulted.²

NOTE 2—It has been found by experience that these ASTM Thermometers, although developed in general for specific tests, may also be found suitable for other applications, thus precluding the need for new thermometer specifications differing in only minor features. However, it is suggested that technical committees contact Subcommittee E20.05 before choosing a currently specified thermometer for a new method to be sure the thermometer will be suitable for the intended application.

1.6 This standard does not purport to address all of the safety concerns, if any, associated with its use. It is the responsibility of the user of this standard to establish appropriate safety and health practices and determine the applicability of regulatory limitations prior to use.

2. Referenced Documents

2.1 ASTM Standards:³

E 77 Test Method for Inspection and Verification of Thermometers

E 344 Terminology Relating to Thermometry and Hydrometry

E 563 Practice for Preparation and Use of an Ice-Point Bath as a Reference Temperature

E 2251 Specification for Liquid-in-Glass ASTM Thermometers with Low-Hazard Precision Liquids

3. Terminology

3.1 *Definitions*—The definitions given in Terminology E 344 apply.

3.2 *Definitions of Terms Specific to This Standard:*

3.2.1 *adjusting device, n*—a section of the instrument used to adjust the amount of mercury in the bulb and main capillary to that needed for the intended temperature interval.

3.2.2 *bulb length, n*—the distance from the bottom of the bulb to the junction of the bulb and the stem tubing.

3.2.3 *contraction chamber, n*—an enlargement of the capillary, that will appear below the main scale or between the main scale and the auxiliary scale, which serves to reduce its length or to prevent contraction of the liquid column into the bulb.

3.2.4 *diameter, n*—the largest outside dimension of the glass as measured with a ring gage.

3.2.5 *expansion chamber, n*—an enlargement at the top of the capillary to provide protection against breakage caused by excessive gas pressure.

3.2.6 *interval error, n*—the deviation of the nominal value of a temperature interval from its true value; either for the total range (total interval) or for a part of the range (partial interval).

3.2.7 *saddle, n*—the bottom support of the enclosed scale.

3.2.8 *setting temperature, n*—the temperature that yields a reading of zero on the main scale for a given adjustment of the amount of mercury in the bulb and main capillary.

3.2.9 *thermometric liquid, n*—the liquid in a liquid-in-glass thermometer that indicates the value of temperature.

3.2.10 *top of the thermometer, n*—the top of the finished instrument.

3.2.10.1 *total length, n*—the distance from the bottom of the bulb to the top of the finished thermometer, including any special finish at the top.

3.2.1+2 Other descriptions of terms shall be in accordance with the Terminology section of Test Method E 77.

Part A—Solid-Stem Thermometers

4. Specifications

4.1 The individual thermometers shall conform to the detailed specifications given in Table 1 and to the general requirements specified in Sections ~~5-13~~.

NOTE 3—~~Such thermometers 5-15.~~

4.2 ~~Thermometers manufactured prior to the adoption of previous revisions of this specification shall retain the same official ASTM status as those meeting current specifications.~~ NOTE 4—~~Encapsulating~~

4.3 ~~The encapsulation (jacketing) of the glass of liquid-in-glass thermometers with polyfluorinated hydrocarbons will change their performance and physical characteristics, including, but not limited to, response time, accuracy, and physical dimensions. Therefore, under no circumstances should an encapsulated or otherwise modified ASTM thermometer be used in performing tests that specify the use of an ASTM thermometer.~~

5. Type

5.1 ~~Eac~~The thermometers, as specified in Table 1, shall be filled with one of the ~~mercury-in-glass type, unless otherwise specified in Table 1.~~ The following liquids:

² Available from SAMA Group of Assocs., 225 Reinekers, Ste. 625, Alexandria, VA 23314.

³ For referenced ASTM standards, visit the ASTM website, www.astm.org, or contact ASTM Customer Service at service@astm.org. For *Annual Book of ASTM Standards*, Vol 14.03, volume information, refer to the standard's Document Summary page on the ASTM website.

- 5.1.1 Mercury,
- 5.1.2 Mercury thallium eutectic alloy, or
- 5.1.3 Toluene or other suitable liquid colored with a permanent red dye.
- 5.2 The filling above the liquid shall be nitrogen or other suitable inert gas.

6. Stem

6.1 *Stem*—The stem shall be made of suitable thermometer tubing and shall have a plain front and enamel back, unless otherwise specified in Table 1.

6.2 *Top Finish*— The top of all thermometers specified in Table 1 shall have a plain rounded finish, except the following which shall have the top finish indicated below (unless indicated as optional):

6.2.1 *Glass Button Finish*:

Thermometers 23C, 24C, and 25C

6.2.2 *Special Finish*:

6.2.2.1 Suitable for assembly in a standard 304.8-mm (12-in.) non-sparking metal armor with open face; in a cup case assembly; or in a flushing case assembly:

Thermometers 58C, 58F, 59C, 59F, 60C, 60F, 97C, 97F, 98C, 98F, 130C, and 130F

6.2.2.2 Suitable for assembly in a 12-in. non-sparking metal armor with open face:

Thermometer 99F

6.2.3 *Ring Top* (optional only)—Thermometers 11C and 11F.

7. Bulb

7.1 The bulb shall be made of glass having a viscosity of at least $10^{14.6}$ poises at 490 °C (914 °F) and at least $10^{13.4}$ poises at 520 °C (968 °F). ~~NOTE 5—Thermometers~~

7.2 ~~Thermometers made with bulb glasses having properties close to these~~ not meeting the minimum requirements should properties in 7.1 shall not be subjected to temperatures above 405 °C (760 °F) or be continuously exposed to temperatures above 370 °C (700 °F).

8. Capillary Clearances

8.1 The following distances between graduations and the bulb, and between graduations and enlargements in the capillary, shall be minimum limits for thermometers in this specification.

~~NOTE 3—In order that for a thermometer scale to be usable over its entire graduated range, graduation marks must should not be placed too close to any enlargement in the capillary. Insufficient immersion of the mercury thermometric liquid in the main bulb or capillary enlargement, graduation marks placed over parts of the capillary that have been changed by manufacturing operations, or graduations so close to the top of the thermometer that excessive gas pressure results when the mercury thermometric liquid is raised to this level, may lead to appreciable errors. The following distances between graduations and the bulb and between graduations and enlargements in the bore are considered as minimum limits for thermometers acceptable for certification.~~

~~8.1.1 Due to a change in the method used for scale placement, it is possible to manufacture thermometers that comply with the specifications given in Table 1, but do not meet the requirements for capillary clearances given below. In any case, the distances given in this section are the governing factor. Under no circumstances should the scales on thermometers be placed closer than these minimum distances:~~

~~8.1.2 A errors.~~

~~8.1.1 A 13-mm length of unchanged capillary between the bulb and the immersion line or lowest graduation, if the graduation is not above 100 °C (212 °F); a 30-mm length if the graduation is above 100 °C (212 °F).~~

~~8.1.32 A 5-mm length of unchanged capillary between an enlargement and the graduation next below, except at the top of the thermometer.~~

~~8.1.43 A 10-mm length of unchanged capillary between an enlargement, other than the bulb, and the immersion line or the graduation next above, if the graduation is not above 100 °C (212 °F); a 30-mm length if the graduation is above 100 °C (212 °F).~~

~~8.1.54 A 10-mm length of unchanged capillary above the highest graduation, if there is an expansion chamber at the top of the thermometer; a 30-mm length if there is no expansion chamber. For the purposes of this requirement, “an expansion chamber” is interpreted as an enlargement at the top end of the capillary bore which shall have a capacity equivalent to not less than 20 mm of unchanged capillary.~~

8.2 It is possible to manufacture thermometers that comply with the specifications given in Table 1, but do not meet the requirements for capillary clearances given above. In any case, the distances given in this section shall be the governing factor. Under no circumstances shall the scales on thermometers be placed closer than these minimum distances.

9. Graduations and Inscriptions

9.1 All graduation lines, immersion lines, figures, and letters shall be clearly defined, suitably colored, and permanent. The

width and the sharpness of the graduation lines shall be in accordance with 9.2. The middle of the graduation line shall be determinable.

9.1.1 A suitably etched thermometer with the etched lines and figures filled with a pigment shall be considered permanently marked provided it passes the test for permanency of pigment in Test Method E 77.

9.1.2 A thermometer marked by other means shall also be considered permanently marked, provided it passes the test for permanency of pigment in Test Method E 77.

9.2 *Graduation Lines*—All graduation lines shall be straight, of uniform width, and perpendicular to the axis of the thermometer. The width of the graduation lines shall be as follows:

9.2.1 *Group 1*—Maximum line width 0.10 mm; for thermometers that may read to fractions of a division, often with magnifying aids:

—Thermometers 14C, 14F, 26C, 28C, 28F, 29C, 29F, 30F, 33C, 33F, 34C, 34F, 35C, 35F, 44C, 44F, 45C, 45F, 46C, 46F, 47C, 47F, 48C, 48F, 50F, 51F, 52C, 56C, 56F, 62C, 62F, 63C, 63F, 64C, 64F, 65C, 65F, 66C, 66F, 67C, 67F, 68C, 68F, 69C, 69F, 70C, 70F, 72C, 72F, 73C, 73F, 74C, 74F, 89C, 90C, 91C, 92C, 93C, 94C, 95C, 96C, 100C, 101C, 110C, 110F, 111C, 112C, 113C, 113F, 116C, 117C, 118C, 118F, 119C, 119F, 120C, 121C, 126C, 126F, 127C, 128C, 128F, 129C, 129F, 132C, and 133C.

Thermometers 14C, 14F, 26C, 28C, 28F, 29C, 29F, 30F, 33C, 33F, 34C, 34F, 35C, 35F, 44C, 44F, 45C, 45F, 46C, 46F, 47C, 47F, 48C, 48F, 50F, 51F, 52C, 56C, 56F, 62C, 62F, 63C, 63F, 64C, 64F, 65C, 65F, 66C, 66F, 67C, 67F, 68C, 68F, 69C, 69F, 70C, 70F, 72C, 72F, 73C, 73F, 74C, 74F, 89C, 90C, 91C, 92C, 93C, 94C, 95C, 96C, 100C, 101C, 110C, 110F, 111C, 112C, 113C, 113F, 116C, 117C, 118C, 118F, 119C, 119F, 120C, 121C, 126C, 126F, 127C, 128C, 128F, 129C, 129F, 132C, 133C, and 137C.

9.2.2 *Group 2*—Maximum line width 0.15 mm; for thermometers that may be read to the nearest half division or where the congestion of scale dictates the use of a scale with moderate fineness:

—Thermometers 1C, 1F, 2C, 2F, 3C, 3F, 5C, 5F, 6C, 6F, 7C, 7F, 8C, 8F, 9C, 9F, 10C, 10F, 11C, 11F, 12C, 12F, 13C, 15C, 15F, 16C, 16F, 17C, 17F, 18C, 18F, 19C, 19F, 20C, 20F, 21C, 21F, 22C, 22F, 23C, 24C, 25C, 36C, 37C, 38C, 39C, 40C, 41C, 42C, 43C, 43F, 49C, 54C, 54F, 61C, 61F, 71C, 71F, 82C, 82F, 83C, 83F, 84C, 84F, 85C, 85F, 86C, 86F, 87C, 87F, 99C, 99F, 102C, 103C, 104C, 105C, 106C, 107C, 108F, 109F, 114C, 122C, 123C, 124C, and 125C.

Thermometers 1C, 1F, 2C, 2F, 3C, 3F, 5C, 5F, 6C, 6F, 7C, 7F, 8C, 8F, 9C, 9F, 10C, 10F, 11C, 11F, 12C, 12F, 13C, 15C, 15F, 16C, 16F, 17C, 17F, 18C, 18F, 19C, 19F, 20C, 20F, 21C, 21F, 22C, 22F, 23C, 24C, 25C, 36C, 37C, 38C, 39C, 40C, 41C, 42C, 43C, 43F, 49C, 54C, 54F, 61C, 61F, 71C, 71F, 82C, 82F, 83C, 83F, 84C, 84F, 85C, 85F, 86C, 86F, 87C, 87F, 99C, 99F, 102C, 103C, 104C, 105C, 106C, 107C, 108F, 109F, 114C, 122C, 123C, 124C, 125C, 134C, 135C, 135F, 136C, and 136F.

9.2.3 *Group 3*—Maximum line width 0.20 mm; for thermometers with more open scales, usually read to the nearest division, often times under adverse conditions where a bold graduation is therefore desired:

Thermometers 27C, 57C, 57F, 58C, 58F, 59C, 59F, 60C, 60F, 75F, 76F, 77F, 78F, 79F, 80F, 81F, 88C, 88F, 97C, 97F, 98C, 98F, 130C, and 130F.

NOTE 6—A maximum line width of 0.10 mm is recommended for thermometers that may be read to fractions of a division, many times with magnifying aids; 0.15 mm for thermometers that may be read to the nearest half division or where the congestion of the scale dictates the use of a scale of moderate fineness; and finally 0.20 mm maximum for thermometers with more open scales usually read to the nearest division, often times under adverse conditions, where a bold graduation is therefore desired.

9.3 *Immersion Line*—On partial immersion thermometers an immersion line shall be permanently marked on the front of the thermometer at the distance above the bottom of the bulb as specified in Table 1 within a tolerance of ± 0.5 mm, except for Thermometers 82F to 87F, which shall have no immersion line. The immersion inscription shall be written in capital letters and abbreviated (for example, 76 mm immersion shall be written 76 MM IMM).

9.4 *Terminal Numbers*—The terminal number shall be in full when there are one or more numbered graduations between it and the next last full number, for example on Thermometer 12C, before the terminal numbers would be 100, 1, 102 °C; number. This rule need not necessarily be followed for:

9.4.1 *Saybolt Viscosity Thermometers* :

—17C, 17F, 18C, 18F, 19C, 19F, 20C, 20F, 21C, 21F, 22C, 22F, 77F, 78F, 79F, 80F, and 81F
17C, 17F, 19C, 19F, 20C, 20F, 21C, 21F, 77F, 78F, 79F, 80F, and 81F

9.4.2 *Kinematic Viscosity Thermometers* :

28F, 29F, 30F, 44F, 45F, 46F, 47F, 48F, 72F, 73F, 74F, 110F, 118F, 126F, 128F, and 129F

9.4.3 *Engler Viscosity Thermometers :*

23C, 24C, and 25C

9.4.4 *Precision Thermometers:*

65F, 66F, 67C, 67F, and 68C

9.4.5 *Tank Thermometer:*

97F

9.4.6 *Solidification Point Thermometers :*

100C and 101C

9.4.7 *Reid Vapor Pressure:*

18C and 18F

9.4.8 *Oxidation Stability:*

22C and 22F

9.5 *Scale Below Zero*—When a scale extends both above and below 0 °C or 0 °F, the two parts of the scale shall be differentiated by some means. Examples of suitable means are:

- 9.5.1 Different pigment colors for the two parts of the scale,
- 9.5.2 Different style of numerical characters for the two parts of the scale, and
- 9.5.3 Use of minus signs before appropriate numbers below 0 °C or 0 °F.

10. Special Inscription

10.1 The special inscription specified in Table 1 shall be marked on the thermometer in capital letters and ~~a~~ Arabic numbers without the use of periods. In addition to the special inscription prescribed in Table 1, each thermometer shall be permanently marked with a unique serial number and the manufacturer’s tradename or mark. ~~NOTE 7—Include year of current revision in ASTM Designation (for example, ASTM 1C-99).~~

10.2 *Engraving Revision Date on ASTM Thermometers*—~~If a thermometer’s specification was changed, the~~ Include year that it was changed is engraved on the back of the thermometer after the current revision in ASTM designation. ~~F~~ (for example, “12C-98.” ASTM 1C-99).

11. Permanency of Pigment

11.1 The test for permanency of pigment shall be performed on any convenient portion of the scale section of the thermometer. The pigment shall not chalk, burn out, or loosen as a result of this test (see Test Method E 77).

12. Bulb Stability

12.1 The test for bulb stability shall be made for the following thermometers in the temperature range specified below for 24 h. The scale error indications after the test shall be within the maximum scale error specified in Table 1. Observations of a reference point before and after the test to give a measure of the degree of bulb stability achieved in manufacture. The bulb is considered stable if the change in indications of the thermometer in the test is no more than 0.7 (7/10) of the maximum scale error found in Table 1. Reference should be made to Test Method E 77.

ASTM Thermometer Number	Test Temperature Range
3C, 8C, 10C, 11C, 70C	360 to 370°C
3F, 8F, 10F, 11F, 70F	680 to 700°F
2C, 7C, 69C, 107C	280 to 290°C
2F, 7F, 69F	540 to 560 °F

~~The change in bulb volume in this test shall not exceed 0.7 of the allowable scale error.~~

13. Scale Error

13.1 Thermometers shall be verified and calibrated at the temperatures specified in Table 4:

~~13.1.1 Scale errors must. Partial immersion thermometers shall be within calibrated for the stated tolerances at emergent stem temperatures specified in Table 4.~~

13.1.1 At the time of purchase, the scale errors shall be within the maximum scale error found in Table 1. The indications of many high temperature and fractionally graduated thermometers may change with time and continued use; due to minute changes in bulb volume. Periodic re verification of these thermometers, either over the entire scale or reverification at a reference temperature (ice point or steam point), in accordance with procedures set forth in Test Method E 77, is recommended.

13.2 Due to the application requirements for range and construction of the following thermometers, it is not practical to include reference points such as the ice and steam points.

13C, 14C, 14F, 17C, 17F, 18C, 18F, 19C, 19F, 20C, 20F, 21C, 21F, 23C, 24C, 26C, 27C, 38C, 49C, 50F, 51F, 56C, 56F, 76F, 77F, 78F, 79F, 80F, 81F, 83C, 83F, 84C, 84F, 87C, 87F, 91C, 92C, 93C, 96C, 98C, 98F, 100C, 101C, 102C, 103C, 104C, 105C, 106C, 107C, 108F, 109F, 111C, 116C, 117C, 122C, 123C, and 124C

14. Case

14.1 Each thermometer shall be supplied in a suitable case on which shall appear the following marking (except when a transparent case is used): the letters “ASTM,” the thermometer number (33C, 33F, etc.), and the temperature range.

15. Methods of Verification and Calibration

15.1 Thermometers shall be verified and calibrated at the specified immersion in accordance with Test Method E 77.

15.2 For partial immersion thermometers, careful consideration of emergent stem temperatures shall be observed.

15.2.1 During the manufacture of partial immersion thermometers, the manufacturer shall calibrate the thermometers so the indicated temperatures are within the maximum permissible errors found in Table 1 when the emergent stem temperatures found in Table 4 are applied to the readings.

NOTE 4—To achieve the requirements in 15.2.1, the manufacturer may have to measure emergent stem temperatures above its bath, calculate correction factors, and offset its calibrations accordingly. See Test Method E 77 for the procedure to correct for emergent stem temperatures.

TABLE 1 Specification for ASTM Thermometers

All dimensions are in millimeters.
See Table 4 for Verification and Calibration Temperatures.

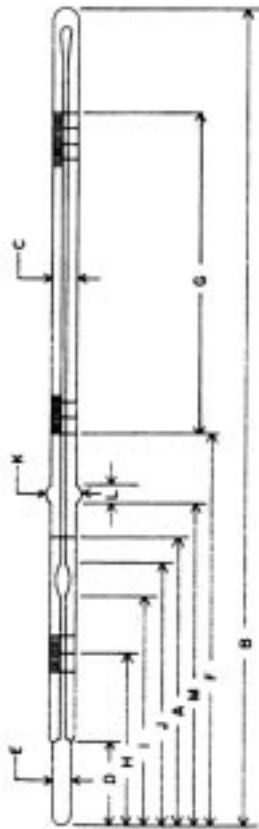
Explanatory Notes:

- ^A An expansion chamber is provided for relief of gas pressure to avoid distortion of the bulb at higher temperatures. It is not for the purpose of joining mercury separations and under no circumstances should the thermometer be heated above the highest temperature reading.
- ^B Toluene or other suitable liquid colored red with a permanent dye shall be used as the actuating liquid.
- ^C Under certain test conditions, the bulb of the thermometer may be 28 °C (50 °F) above the temperature indicated by the thermometer, and at an indicated temperature of 374 °C (700 °F) the temperature of the bulb is approaching a critical range in the glass. It is therefore not desirable to use this thermometer under such conditions at indicated temperatures above 371 °C (700 °F) without checking the ice point.
- ^D Longest graduation lines at 155 °C, 160 °C, 162 °C, 164 °C, 165 °C, and 170 °C, with arrows at 162 °C and 164 °C.
- ^E The length of the enlargement, and the distance from the bottom of the enlargement to the bottom of the bulb shall be measured with the test gage shown in Fig. 1.
- ^F Long, narrow shape.
- ^G The test temperature shall be indicated by an arrow whether the graduation corresponding to that point is numbered or not.
- ^H Long, narrow shape; mercury shall be in the chamber at 0 °C (32 °F).
- ^I The thermometer shall be made to be mounted in a brass ferrule consisting of a tubular bushing 8.0 mm in outside diameter with a flanged head approximately 12 mm in diameter so that the upper extremity of the 8.0 mm diameter is located 90 mm from the bottom of the bulb.
- ^J To be marked on the glass stem at least 90 mm from the bottom of the bulb.
- ^K Glass button finish, see 6.2.1.
- ^L Long, narrow shape; mercury shall be near bottom of the chamber at 0 °C.
- ^M For kinematic viscosity thermometers, the ice-point reading shall be taken within 1 h after being at the test temperature for not less than 3 minutes. The ice-point reading shall be expressed to the nearest 0.01 °C or 0.02 °F and applied as explained in Test Method E 77, Section 13.
- ^N Thermometers made to these specifications conform also with the requirements for the titer test thermometer of the American Oil Chemists Society and the Association of Official Agricultural Chemists, except for the special inscription.
- ^O Capillary clearances must conform to Section 8.
- ^P Mercury shall be near middle of chamber at 0 °C.
- ^Q The stem may be either the plain front or lens front type. If the thermometer is of the lens front type, the cross section of the stem shall be such that it will pass through an 8-mm ring gage but will not enter a 5-mm slot gage.
- ^R A suitable mercury-thallium alloy shall be used as the actuating liquid.
- ^S The expansion chamber shall be of the long narrow type 10 to 20 mm in length. The length of unchanged capillary between the nearest graduation mark and the expansion chamber shall be not less than 10 mm.
- ^T Mercury shall be near the bottom of the chamber at 0 °C.
- ^U The length of unchanged capillary between the nearest graduation mark and contraction chamber shall be not less than 10 mm.
- ^V Change in correction over any 5 °F interval shall not exceed 0.10 °F.
- ^W Expansion chamber shall be of the long narrow type and there shall be not less than 10 mm of unchanged capillary between the base of the chamber and the top graduation.
- ^X Mercury shall be in the chamber at 32 °F.
- ^Y Over any interval of 2 °C the change in correction shall not exceed 0.02 °C.
- ^Z Over any interval of 4 °F the change in correction shall not exceed 0.05 °F.
- ^{AA} Special finish, see 6.2.2.
- ^{BB} The bulb diameter shall not be more than 0.5 mm greater than the stem.
- ^{CC} The stem shall be of the lens front type. The cross section of the stem shall be such that it will pass through a 8.0-mm ring gage but will not enter a 5.0-mm slot gage. A minor diameter of 4 mm is permissible provided that the major diameter is not less than 7 mm.
- ^{DD} Bulb bottom shall be essentially hemispherical.

- EE* Immersion line shall be omitted.
- FF* For Fahrenheit thermometers, dimension G (length of graduated portion) shall be measured as the length of graduated portion corresponding to the nominal Celsius range.
- GG* The immersion line shall be visible in the case opening after assembly. The immersion shall be measured from the bottom of the bulb rather than from the bottom of the armor. See 6.2.2.
- HH* The stem shall be either the round or lens-front type.
- I* Contraction chamber to be long narrow type.
- JJ* Over any interval of 1 °C the change in correction shall not exceed 0.01 °C. The correction at the lowest temperature of the nominal range shall not change by more than 0.02 °C immediately after the thermometer has been heated for 15 min at a temperature 30 °C higher, and allowed to cool naturally in air.
- KK* The capillary bore shall be large enough in relation to the bulb to ensure that (without tapping) jumping of the meniscus does not exceed one half of the smallest scale division, when the temperature is rising at a uniform rate not exceeding 0.05 °C/min.
- LL* The thermometer is to be calibrated for 100-mm immersion for the main scale, the ice point is to be calibrated for total immersion.
- MM* Bulb shape ellipsoidal (see Fig. 2).
- NN* This thermometer may be furnished with an optional ring top. See 6.2.3. Addition of a ring top will increase the total length by an amount equal to the outside diameter of the ring.
- OO* The stem shall be of the lens front type. The cross section of the stem shall be such that it will pass through a 7.0 mm ring gage.

TABLE 1 Continued

ASTM No.	1C-99	1F-99 ^{FF}	2C-99	2F-99 ^{FF}	3C-99	3F-99 ^{FF}
IP No.			62C	73C		
Name						
Reference Fig. No.						
Range	-20 to +150°C	0 to 302°F	-5 to +300°C	20 to 580°F	-5 to +400°C ^C	20 to 760°F ^C
For test at						
A Immersion, mm		3		3		3
Graduations:		76		76		76
Subdivisions	1°C	2°F	1°C	2°F	1°C	2°F
Long lines at each	5°C	10°F	5°C	10°F	5°C	10°F
Numbers at each	10°C	20°F	10°C	20°F	10°C	20°F
Scale error, max	0.5°C	1°F	1°C	2°F	1°C to 301°C	2°F to 574°F
					1.5°C above	3°F above
					301°C	574°F
Special inscription		ASTM 1C-99 or 1F-99 76 MM IMM		ASTM 2C-99 or 2F-99 76 MM IMM	ASTM 3C-99 or 3F-99 76 MM IMM	
Expansion chamber:						
Permit heating to		200°C				
B Total length, mm		317 to 327		385 to 395		410 to 420
C Stem OD, mm		6.0 to 7.0		6.0 to 7.0		6.0 to 7.5
D Bulb length, mm		19 to 25		10 to 15		10 to 15
E Bulb OD, mm		5.0 to 6.0		5.0 to 6.0		5.0 to 6.0
Scale location:						
Bottom of bulb to line at	0°C	32°F	0°C	32°F	0°C	32°F
F Distance, mm		111 to 118		100 to 110		100 to 110
G Length of graduated portion, mm		170 to 200 ^O		225 to 265 ^O		250 to 290 ^O
Ice-point scale:						
Range						
H Bottom of bulb to ice-point, mm						
Contraction chamber:						
I Distance to bottom, min, mm						
J Distance to top, max, mm						
Stem enlargement:						
K OD, mm						
L Length, mm						
M Distance to bottom, mm						

^A An expansion chamber is provided for relief of gas pressure to avoid distortion of the bulb at higher temperatures. It is not for the purpose of joining mercury separations and under no circumstances should the thermometer be heated above the highest temperature reading.

^B Under certain test conditions, the bulb of the thermometer may be 28°C (50°F) above the temperature indicated by the thermometer, and at an indicated temperature of 371°C (700°F) the temperature of the bulb is approaching a critical range in the glass. It is therefore not desirable to use this thermometer under such conditions at indicated temperatures above 371°C (700°F) without checking the ice point.

^O Capillary clearances shall conform to Section 8.

^{FF} For Fahrenheit thermometers, dimension G (length of graduated portion) shall be measured as the length of graduated portion corresponding to the nominal Celsius range.

TABLE 1 Continued

ASTM No.	5C-86	5F-86 ^{FF}	6C-86	6F-86 ^{FF}	7C-86	7F-86 ^{FF}
IP No.	1C	2C	3C	4C	5C	6C
Name	Cloud and Pour	Low Cloud and Pour ^B	Low Distillation			
Reference Fig. No.	3	3	4			
Range	-38 to +50°C	-80 to +20°C	-112 to +70°F	-2 to +300°C	30 to 580°F	
For test at						
A Immersion, mm	108	76				
Graduations:						
Subdivisions	1°C	1°C	2°F	1°C	2°F	
Long lines at each	5°C	5°C	10°F	5°C	10°F	
Numbers at each	10°C	10°C	20°F	10°C	20°F	
Scale error, max	0.5°C	1°C to -33°C	2°F to -28°F	0.5°C to 150°C	1°F to 300°F	
Special inscription	ASTM 5C-86 or 5F-86 108 MM IMM	2°C below -33°C	4°F below -28°F	1°C above 150°C	2°F above 300°F	ASTM
Expansion chamber:			ASTM	ASTM	ASTM	
Permit heating to			6C-86 or 6F-86	6C-86 or 7F-86	7C-86 or 7F-86	
B Total length, mm	100°C	60°C	76 MM IMM			
C Stem OD, mm						
D Bulb length, mm						
E Bulb OD, mm						
Scale location:						
Bottom of bulb to line at						
F Distance, mm						
G Length of graduated portion, mm						
Ice-point scale:						
Range						
H Bottom of bulb to ice-point, mm						
Contraction chamber:						
I Distance to bottom, min, mm						
J Distance to top, max, mm						
Stem enlargement:						
K OD, mm						
L Length, mm						
M Distance to bottom, mm						

^A An expansion chamber is provided for relief of gas pressure to avoid distortion of the bulb at higher temperatures. It is not for the purpose of joining mercury separations and under no circumstances should the thermometer be heated above the highest temperature reading.

^B Toluene or other suitable liquid colored red with a permanent dye shall be used as the actuating liquid.

^C Capillary clearances shall conform to Section 8.

^{FF} For Fahrenheit thermometers, dimension G (length of graduated portion) shall be measured as the length of graduated portion corresponding to the nominal Celsius range.

TABLE 1 Continued

ASTM No.	8C-86	8F-86 ^{FF}	9C-86	9F-86 ^{FF}	10C-86	10F-86 ^{FF}
IP No.	6C	15C	16C			
Name		High Distillation		Low-Pensky-Martens		High-Pensky-Martens
Reference Fig. No.		4		5		5
Range	-2 to + 400°C ^C	30 to 760°F ^C	-5 to + 110°C	20 to 230°F	90 to 370°C	200 to 700°F
For test at		total				
A Immersion, mm				57		57
Graduations:						
Subdivisions	1°C	2°F	0.5°C	1°F	2°C	5°F
Long lines at each	5°C	10°F	1°C and 5°C	5°F	10°C	25°F
Numbers at each	10°C	20°F	5°C	10°F	20°C	50°F
Scale error, max	1°C to 300°C	2°F to 570°F	0.5°C	1°F	1°C to 260°C	2.5°F to 500°F
Special inscription	1.5°C above 300°C	3°F above 570°F			2°C above 260°C	3.5°F above 500°F
		ASTM		ASTM		ASTM
		8C-86 or 8F-86		9C-86 or 9F-86		10C-86 or 10F-86
				57 MM IMM		57 MM IMM
Expansion chamber:						
Permit heating to						
B Total length, mm		160°C		320°F		
C Stem OD, mm						
D Bulb length, mm						
E Bulb OD, mm						
Scale location:						
Bottom of bulb to line at	0°C				90°C	200°F
F Distance, mm						80 to 90
G Length of graduated portion, mm						145 to 180 ^D
Ice-point scale:						
Range						
H Bottom of bulb to ice-point, mm						
Contraction chamber:						
I Distance to bottom, min, mm						
J Distance to top, max, mm						
Stem enlargement						
K OD, mm						7.5 to 8.5
L Length, mm						2.5 to 5.0 ^E
M Distance to bottom, mm						64 to 66

^A An expansion chamber is provided for relief of gas pressure to avoid distortion of the bulb at higher temperatures. It is not for the purpose of joining mercury separations and under no circumstances should the thermometer be heated above the highest temperature reading.

^C Under certain test conditions, the bulb of the thermometer may be 28°C (50°F) above the temperature indicated by the thermometer, and at an indicated temperature of 371°C (700°F) the temperature of the bulb is approaching a critical range in the glass. It is therefore not desirable to use this thermometer under such conditions at indicated temperatures above 374°C (700°F) without checking the ice point.

^E The length of the enlargement, and the distance from the bottom of the bulb shall be measured with the test gage shown in Fig. 1.

^D Capillary clearances shall conform to Section 8.

^{FF} For Fahrenheit thermometers, dimension G (length of graduated portion) shall be measured as the length of graduated portion corresponding to the nominal Celsius range.

TABLE 1 Continued

ASTM No.	11C-86	11F-86 ^{FF}	12C-86	12F-86 ^{FF}	13C-86
IP No.	28C		64C	64F	47C
Name		Cleveland Open Flash		Density-Wide Range	Loss on Heat
Reference Fig. No.		3		4	9
Range	-6 to + 400°C ^C	20 to 760°F ^C	-20 to + 102°C	-5 to + 215°F	155 to 170°C
For test at		25		total	total
A Immersion, mm					0.5°C
Graduations:					1°C ^D
Subdivisions	2°C	5°F	0.2°C	0.5°F	155°C, 160°C, 165°C,
Long lines at each	10°C	10°F	1°C	1°F	170°C
Numbers at each	20°C	20°F	2°C	5°F	0.5°C
Scale error, max	2°C to 260°C	5°F to 500°F	0.15°C	0.25°F	ASTM
Special inscription	4°C above 260°C	7°F above 500°F			13C-86
Expansion chamber:		ASTM			
Permit heating to		11C-86 or 11F-86			
Total length, mm		25 MM IMM			
Stem OD, mm		^A	150°C		200°C
Bulb length, mm		305 to 315 ^{MM}			150 to 160
Bulb OD, mm		6.0 to 8.0			5.5 to 7.0
Scale location:		7 to 10			10 to 15
Bottom of bulb to line at	0°C	32°F	-20°C		155°C
Distance, mm		45 to 55			50 to 60
Length of graduated portion, mm		210 to 240 ^O			40 to 60 ^O
Ice-point scale:					
Range					
Bottom of bulb to ice-point, mm					
Contraction chamber:					
Distance to bottom, min, mm					
Distance to top, max, mm					
Stem enlargement:					
OD, mm					
Length, mm					
Distance to bottom, mm					
					30°F

^A An expansion chamber is provided for relief of gas pressure to avoid distortion of the bulb at higher temperatures. It is not for the purpose of joining mercury separations, and under no circumstances should the thermometer be heated above the highest temperature reading.

^C Under certain test conditions, the bulb of the thermometer may be 28°C (50°F) above the temperature indicated by the thermometer, and at an indicated temperature of 371°C (700°F) the temperature of the bulb is approaching a critical range in the glass. It is therefore not desirable to use this thermometer under such conditions at indicated temperatures above 371°C (700°F) without checking the ice point.

^D Longest graduation lines at 155°C, 160°C, 162°C, 164°C, 165°C, and 170°C, with arrows at 162°C and 164°C.

^F Long, narrow shape.

^O Capillary clearances shall conform to Section 8.

^{FF} For Fahrenheit thermometers, dimension G (length of graduated portion) shall be measured as the length of graduated portion corresponding to the nominal Celsius range.

^{MM} This thermometer may be furnished with an optional ring top. See 6.2.3. Addition of a ring top will increase the total length by an amount equal to the outside diameter of the ring.

TABLE 1 Continued

ASTM No.	14C-86	14F-86 ^{FF}	60C	15C-86	15F-86 ^{FF}	16C-86	16F-86 ^{FF}
IP No.	17C					61C	
Name	Wax Melting Point					High Softening Point	
Reference Fig. No.	7	100 to 180°F	-2 to + 80°C		30 to 180°F	30 to 200°C	85 to 392°F
Range	38 to 82°C				4	4	
For test at					total	total	
A	Immersion, mm						
	Graduations:						
	Long lines at each	0.2°F	0.2°C		0.5°F	0.5°C	1°F
	Numbers at each	1°F	1°C		1°F	1°C	5°F
	Scale error, max	2°F	2°C		5°F	5°C	10°F
	Special inscription	0.2°F	0.2°C		0.4°F	0.3°C	0.5°F
		ASTM			ASTM	ASTM	
		14C-86 or 14F-86			15C-86 or 15F-86	16C-86 or 16F-86	
		79 MM IMM					
Expansion chamber:							
B	Permit heating to						
C	Total length, mm	370 to 380	130°C		270°F	250°C	482°F
D	Stem OD, mm	6.0 to 8.0			390 to 400		390 to 400
E	Bulb length, mm	18 to 28			6.0 to 8.0		6.0 to 8.0
	Bulb OD, mm	5.0 to 6.0			9 to 14		9 to 14
	Scale location:				4.5 to 5.5		4.5 to 5.5
F	Bottom of bulb to line at						
G	Distance, mm	115 to 125	0°C		32°F	30°C	86°F
	Length of graduated portion, mm	210 to 240 ^o			75 to 90		75 to 90
	Ice-point scale:				245 to 285 ^o		245 to 280 ^o
H	Range						
	Bottom of bulb to ice-point, mm						
I	Contraction chamber:						
J	Distance to bottom, min, mm						
	Distance to top, max, mm						
K	Stem enlargement:						
L	OD, mm						
M	Length, mm						
	Distance to bottom, mm						

^o Capillary clearances shall conform to Section 8.

^{FF} For Fahrenheit thermometers, dimension G (length of graduated portion) shall be measured as the length of graduated portion corresponding to the nominal Celsius range.

TABLE 1 Continued

IP No.	ASTM No.	17C-86	17F-86 ^{FF}	18C-86	18F-86 ^{FF}	19C-86	19F-86 ^{FF}
Name				23C			
Reference Fig. No.							
Range							
For test at							
A		17C-86	17F-86 ^{FF}	18C-86	18F-86 ^{FF}	19C-86	19F-86 ^{FF}
Immersion, mm		19 to 27°C	66 to 80°F	34 to 42°C	94 to 108°F	49 to 57°C	120 to 134°F
Graduations:		21.1 and 25°C ^G	70 and 77°F ^G	37.8°C ^G	100°F ^G	50 and 54.4°C ^G	122 and 130°F ^G
Subdivisions						total	total
Long lines at each		0.1°C	0.2°F	0.1°C	0.2°F	0.1°C	0.2°F
Numbers at each		0.5°C	1°F	0.5°C	1°F	0.5°C	1°F
Scale error, max		1°C, except 21	2°F	1°C	2°F	1°C, except 54	2°F
Special inscription		0.1°C	0.2°F	0.1°C	0.2°F	0.1°C	0.2°F
		ASTM	ASTM	ASTM	ASTM	ASTM	ASTM
		17C-86 or 17F-86		18C-86 or 18F-86		19C-86 or 19F-86	
Expansion chamber:							
Permit heating to							
B		100°C	212°F	100°C	212°F	115°C	240°F
Total length, mm							
C		270 to 280		270 to 280		270 to 280	
Stem OD, mm		6.0 to 7.0		6.0 to 7.0		6.0 to 7.0	
D		25 to 35		25 to 35		25 to 35	
Bulb length, mm		←5.0 and →stem		→stem		←5.0 and →stem	
E							
Bulb OD, mm							
Scale location:							
Bottom of bulb to line at							
F		19°C	66°F	34°C	94°F	49°C	120°F
Distance, mm							
G		135 to 150		130 to 150		135 to 150	
Length of graduated portion, mm		67 to 101 ^O		60 to 90 ^O		67 to 101 ^O	
Ice-point scale:							
Range							
H							
Bottom of bulb to ice-point, mm							
Contraction chamber:							
I							
Distance to bottom, min, mm							
J							
Distance to top, max, mm							
K							
Stem enlargement:							
OD, mm							
L		8.0 to 10.0		8.0 to 10.0		8.0 to 10.0	
Length, mm		4.0 to 7.0		4.0 to 7.0		4.0 to 7.0	
M		112 to 116		112 to 116		112 to 116	
Distance to bottom, mm							

^G The test temperatures shall be indicated by an arrow whether the graduation corresponding to that point is numbered or not.

^H Long, narrow shape; mercury shall be in the chamber at 0°C (32°F).

^O Capillary clearances shall conform to Section 8.

^{FF} For Fahrenheit thermometers, dimension G (length of graduated portion) shall be measured as the length of graduated portion corresponding to the nominal Celsius range.

TABLE 1 Continued

ASTM No.	20C-86	20F-86 ^{FF}	21C-86	21F-86 ^{FF}	22C-86	22F-86 ^{FF}
IP No.						
Name						
Reference Fig. No.						
Range						
For test at						
A	Immerision, mm	134 to 148°F ^G	79 to 87°C	174 to 188°F	95 to 103°C	204 to 218°F
	Graduations:	60°C ^G	82.2°C ^G	180°F ^G	98.9 and 100°C ^G	210°F ^G
	Subdivisions					
	Long lines at each	0.1°C	0.1°C	0.2°F	0.1°C	0.2°F
	Numbers at each	0.5°C	0.5°C	1°F	0.5°C	1°F
	Scale error, max	1°C	1°C, except 82	2°F	1°C	2°F
	Special inscription	0.1°C	0.1°C	0.2°F	0.1°C	0.2°F
		ASTM	ASTM	ASTM	ASTM	ASTM
	Expansion chamber:	20C-86 or 20F-86	21C-86 or 21F-86	22C-86 or 22F-86		
	Permit heating to					
B	Total length, mm	115°C	140°C	285°F	155°C	310°F
C	Stem OD, mm	270 to 280	270 to 280		270 to 280	
D	Bulb length, mm	6.0 to 7.0	6.0 to 7.0		6.0 to 8.0	
E	Bulb OD, mm	25 to 35	25 to 35		25 to 35	
	Scale location:	<5.0 and >stem	<5.0 and >stem		<5.0 and >stem	
F	Bottom of bulb to line at	57°C	79°C	174°F	95°C	204°F
	Distance, mm					
G	Length of graduated portion, mm	135 to 150	135 to 150		135 to 150	
	Ice-point scale:	67 to 101 ^o	67 to 101 ^o		70 to 100 ^o	
	Range					
H	Bottom of bulb to ice-point, mm					
	Contraction chamber:					
I	Distance to bottom, min, mm					
J	Distance to top, max, mm					
K	Stem enlargement:					
	OD, mm	8.0 to 10.0	8.0 to 10.0		8.0 to 10.0	
L	Length, mm	4.0 to 7.0	4.0 to 7.0		4.0 to 7.0	
M	Distance to bottom, mm	112 to 116	112 to 116		112 to 116	

^G The test temperatures shall be indicated by an arrow whether the graduation corresponding to that point is numbered or not.

^H Long, narrow shape; mercury shall be in the chamber at 0°C (32°F).

^o Capillary clearances shall conform to Section 8.

^{FF} For Fahrenheit thermometers, dimension G (length of graduated portion) shall be measured as the length of graduated portion corresponding to the nominal Celsius range.

TABLE 1 Continued

	ASTM No.	23C-86	24C-86	25C-86
IP No.				
Name				
Reference Fig. No.				
Range				
For test at				
A Immersion, mm				
Graduations:				
Subdivisions				
Long lines at each				
Numbers at each				
Scale error, max				
Special inscription				
Expansion chamber:				
Permit heating to				
B Total length, mm				
C Stem OD, mm				
D Bulb length, mm				
E Bulb OD, mm				
Scale location:				
Bottom of bulb to line at				
F Distance, mm				
G Length of graduated portion, mm				
Ice-point scale:				
Range				
Bottom of bulb to ice-point, mm				
H Contraction chamber:				
Distance to bottom, min, mm				
Distance to top, max, mm				
I Stem enlargement:				
OD, mm				
L Length, mm				
M Distance to bottom, mm				
Engler Viscosity ⁷				
7 ^k				
18 to 28°C				
25°C				
90				
0.2°C				
1°C				
2°C full figures at 25				
0.1°C at 25°C				
ASTM				
23C-86				
90 MM IMM ⁷				
100°C				
207 to 217				
5.5 to 6.5				
13 to 19				
5.5 to 6.5				
18°C				
108 to 118				
42 to 69 ^o				
0.2°C				
1°C				
2°C full figures at 40 and 50				
0.1°C at 40 and 50°C				
ASTM				
24C-86				
90 MM IMM ⁷				
105°C				
232 to 242				
5.5 to 6.5				
13 to 19				
5.5 to 6.5				
39°C				
108 to 118				
67 to 94 ^o				
0.2°C				
1°C				
2°C full figures at 100				
0.1°C at 100°C				
ASTM				
25C-86				
90 MM IMM ⁷				
155°C				
207 to 217				
5.5 to 6.5				
13 to 19				
5.5 to 6.5				
95°C				
108 to 118				
42 to 69 ^o				
Engler Viscosity ⁷				
7 ^k				
39 to 54°C				
40 and 50°C				
90				
0.2°C				
1°C				
2°C full figures at 40 and 50				
0.1°C at 40 and 50°C				
ASTM				
24C-86				
90 MM IMM ⁷				
105°C				
232 to 242				
5.5 to 6.5				
13 to 19				
5.5 to 6.5				
39°C				
108 to 118				
67 to 94 ^o				
0.2°C				
1°C				
2°C full figures at 100				
0.1°C at 100°C				
ASTM				
25C-86				
90 MM IMM ⁷				
155°C				
207 to 217				
5.5 to 6.5				
13 to 19				
5.5 to 6.5				
95°C				
108 to 118				
42 to 69 ^o				

⁷ The thermometer shall be made to be mounted in a brass ferrule consisting of a tubular bushing 8.0 mm in outside diameter with a flanged head approximately 12 mm in diameter so that the upper extremity of the 8.0 mm diameter is located 90 mm from the bottom of the bulb.

^J To be marked on the glass stem at least 90 mm from the bottom of the bulb.

^K Glass button finish, see 6.2.1.

^L Long, narrow shape; mercury shall be near bottom of the chamber at 0°C.

^O Capillary clearances shall conform to Section 8.

TABLE 1 Continued

ASTM No.	26C-86	27C-86	28C-86	28F-86 ^{FF}
IP No.				
Name	Stability Test of Soluble Nitrocellulose	Turpentine Distillation	Kinematic Viscosity ^M	
Reference Fig. No.	9	7	6	
Range	130 to 140°C	147 to 182°C	36.6 to 39.4°C	97.5 to 102.5°F
For test at	134.5°C		37.8°C	100°F
A	total	76	total	
Immersion, mm				
Graduations:				
Subdivisions	0.1°C	0.5°C	0.05°C	0.1°F
Long lines at each	0.5°C	1°C	0.1 and 0.5°C	0.5 and 1°F
Numbers at each	1°C and in full at 130, 135, 140	2°C from 148	1°C	1°F
Scale error, max	0.2°C	0.5°C	0.1°C	0.2°F
Special inscription	ASTM 26C-86	ASTM 27C-86 76 MM IMM	ASTM 28C-86 or 28F-86	
Expansion chamber:				
Permit heating to	175°C	230°C	105°C	220°F
B Total length, mm	458 to 468	296 to 306		
C Stem OD, mm	6.5 to 8.0	6.0 to 7.0		
D Bulb length, mm	54 to 67	10 to 15		
E Bulb OD, mm	6.0 to 7.0	4.0 to 5.5		
Scale location:				
Bottom of bulb to line at	134.5°C	147°C	36.6°C	97.5°F
F Distance, mm	320 to 340	100 to 115	145 to 165	
G Length of graduated portion, mm	112 to 145 ^O	131 to 166 ^O	40 to 90 ^O	
Ice-point scale:				
Range			-0.3 to +0.3°C ^O	31.5 to 32.5°F ^O
H Bottom of bulb to ice-point, mm				
Contraction chamber:				
I Distance to bottom, min, mm				100
J Distance to top, max, mm	100 ^I	40 ^I		125
Stem enlargement:				
K OD, mm				
L Length, mm				
M Distance to bottom, mm				

^I Long, narrow shape; mercury shall be near bottom of the chamber at 0°C.

^M For kinematic viscosity thermometers, the ice-point reading shall be taken within 1 h after being at the test temperature for not less than 3 minutes. The ice-point reading shall be expressed to the nearest 0.01°C or 0.02°F and applied as explained in Test Method E 77, Section 13.

^O Capillary clearances shall conform to Section 8.

^{FF} For Fahrenheit thermometers, dimension G (length of graduated portion) shall be measured as the length of graduated portion corresponding to the nominal Celsius range.

TABLE 1 Continued

ASTM No.	29C-86	29F-86 ^{FF}	30F-86 ^{FF}	33C-86	33F-86 ^{FF}
IP No.	29C-86	29F-86 ^{FF}	30F-86 ^{FF}	33C-86	33F-86 ^{FF}
Name	34C			20C	
Reference Fig. No.					Low Aniline Point
Range	52.6 to 55.4°C	127.5 to 132.5°F	207.5 to 212.5°F	-38 to +42°C	-36.5 to +107.5°F
For test at	54.4°C	130°F	210°F		
A Immersion, mm		total	total		50
Graduations:					
Subdivisions	0.05°C	0.1°F	0.1°F	0.2°C	0.5°F
Long lines at each	0.1 and 0.5°C	0.5 and 1°F	0.5 and 1°F	1°C	1°F
Numbers at each	1°C	1°F	1°F	2°C	5°F
Scale error, max	0.1°C	0.2°F	0.2°F	0.2°C	0.5°F
Special inscription		ASTM	ASTM		ASTM
		29C-86 or 29F-86	30F-86		33C-86 or 33F-86
					50 MM IMM
Expansion chamber:					
Permit heating to					
B Total length, mm	105°C	220°F	266°F	100°C	212°F
C Stem OD, mm		300 to 310	300 to 310		415 to 425
D Bulb length, mm		6.0 to 8.0	6.0 to 8.0		6.0 to 7.5
E Bulb OD, mm		45 to 55	45 to 55		10 to 20
Scale location:		→stem	→stem		←5.0 and →stem
Bottom of bulb to line at					
F Distance, mm	52.6°C	127.5°F	207.5°F	-35°C	-31°F
G Length of graduated portion, mm		145 to 165	145 to 165		100 to 125
Ice-point scale:		40 to 90°	40 to 90°		240 to 280°
Range	-0.3 to +0.3°C	31.5 to 32.5°F	31.5 to 32.5°F		
H Bottom of bulb to ice-point, mm					
Contraction chamber:					
I Distance to bottom, min, mm		100	100		
J Distance to top, max, mm		125	125		
Stem enlargement:					
K OD, mm					
L Length, mm					
M Distance to bottom, mm					

^M For kinematic viscosity thermometers, the ice-point reading shall be taken within 1 h after being at the test temperature for not less than 3 minutes. The ice-point reading shall be expressed to the nearest 0.01°C or 0.02°F and applied as explained in Test Method E 77, Section 13.

^O Capillary clearances shall conform to Section 8.

^{FF} For Fahrenheit thermometers, dimension G (length of graduated portion) shall be measured as the length of graduated portion corresponding to the nominal Celsius range.

TABLE 1 Continued

ASTM No.	34C-86	34F-86 ^{FF}	35C-86	35F-86 ^{FF}	36C-86
IP No.	21C		59C		
Name		Medium Aniline Point		High Aniline Point	
Reference Fig. No.		3		7	
Range	25 to 105°C	77 to 221°F	90 to 170°C	194 to 338°F	
For test at					Titer Test ^N
A Immersion, mm		50		50	3 -2 to +68°C
Graduations:					45
Subdivisions		0.5°F	0.2°C	0.5°F	0.2°C
Long lines at each	0.2°C	1°F	1°C	1°F	1°C
Numbers at each	1°C	5°F	2°C	5°F	2°C
Scale error, max	2°C	0.5°F	0.4°C	1.0°F	0.2°C
Special inscription	0.2°C	ASTM			ASTM
		34C-86 or 34F-86			36C-86
		50 MM IMM			45 MM IMM
Expansion chamber:					
Permit heating to					
B Total length, mm	150°C	302°F	220°C	428°F	85°C ^o
C Stem OD, mm					400 to 410
D Bulb length, mm					6.0 to 7.5 ^o
E Bulb OD, mm					10 to 20
Scale location:					15 to 25
Bottom of bulb to line at					≤5.5 and ≥stem
F Distance, mm		77°F	90°C	194°F	-2°C
G Length of graduated portion, mm					50 to 60
Ice-point scale:					290 to 320 ^o
Range					
H Bottom of bulb to ice-point, mm					
Contraction chamber:					
I Distance to bottom, min, mm					
J Distance to top, max, mm					
Stem enlargement:					
K OD, mm					
L Length, mm					
M Distance to bottom, mm					
					35 ^P

^N Thermometers made to these specifications conform also with the requirements for the titer thermometer of the American Oil Chemists Society and the Association of Official Agricultural Chemists, except for the special inscription.

^o Capillary clearances shall conform to Section 8.

^P Mercury shall be near middle of chamber at 0°C.

^o The stem may be either the plain front or lens front type. If the thermometer is of the lens front type, the cross section of the stem shall be such that it will pass through an 8-mm ring gage but will not enter a 5-mm slot gage.

^{FF} For Fahrenheit thermometers, dimension G (length of graduated portion) shall be measured as the length of graduated portion corresponding to the nominal Celsius range.

TABLE 1 Continued

	37C-86	38C-86	39C-86
IP No.	77C	78C	79C
Name	Solvents Distillation	Solvents Distillation	Solvents Distillation
Reference Fig. No.	3	3	7
Range	-2 to +52°C	24 to 78°C	48 to 102°C
For test at			
A Immersion, mm	100	100	100
Graduations:			
Subdivisions	0.2°C	0.2°C	0.2°C
Long lines at each	1°C	1°C	1°C
Numbers at each	2°C	2°C	2°C
Scale error, max	0.2°C	0.2°C	0.2°C
Special inscription	ASTM	ASTM	ASTM
	37C-86	38C-86	39C-86
	100 MM IMM	100 MM IMM	100 MM IMM
Expansion chamber:			
Permit heating to	80°C	105°C	130°C
B Total length, mm	390 to 400	390 to 400	390 to 400
C Stem OD, mm	6.0 to 8.0	6.0 to 8.0	6.0 to 8.0
D Bulb length, mm	15 to 20	15 to 20	15 to 20
E Bulb OD, mm	↗stem	↗stem	↗stem
Scale location:			
Bottom of bulb to line at	-2°C	24°C	48°C
F Distance, mm	125 to 145	125 to 145	125 to 145
G Length of graduated portion, mm	190 to 235 ^o	190 to 235 ^o	190 to 235 ^o
Ice-point scale:			
Range			
H Bottom of bulb to ice-point, mm			
Contraction chamber:			
I Distance to bottom, min, mm			
J Distance to top, max, mm			
Stem enlargement:			
K OD, mm			
L Length, mm			
M Distance to bottom, mm			35 [†]

^o Capillary clearances shall conform to Section 8.

[†] Mercury shall be near the bottom of the chamber at 0°C.

TABLE 1 Continued

ASTM No.	40C-86	41C-86	42C-86
IP No.	80C	81C	82C
Name	Solvents Distillation	Solvents Distillation	Solvents Distillation
Reference Fig. No.	7	7	7
Range	72 to 126°C	98 to 152°C	95 to 255°C
For test at			
A Immersion, mm	100	100	100
Graduations:			
Subdivisions	0.2°C	0.2°C	0.5°C
Long lines at each	1°C	1°C	1°C
Numbers at each	2°C	2°C	5°C
Scale error, max	0.2°C	0.3°C	1°C
Special inscription	ASTM 40C-86	ASTM 41C-86	ASTM 42C-86
Expansion chamber:	100 MM IMM	100 MM IMM	100 MM IMM
Permit heating to	150°C	180°C	280°C
B Total length, mm	390 to 400	390 to 400	390 to 400
C Stem OD, mm	6.0 to 8.0	6.0 to 8.0	6.0 to 8.0
D Bulb length, mm	15 to 20	15 to 20	15 to 20
E Bulb OD, mm	>stem	>stem	>stem
Scale location:			
Bottom of bulb to line at			
F Distance, mm	72°C	98°C	95°C
G Length of graduated portion, mm	125 to 145 190 to 235 ^o	125 to 145 190 to 235 ^o	125 to 145 190 to 235 ^o
Ice-point scale:			
Range			
H Bottom of bulb to ice-point, mm			
Contraction chamber:			
I Distance to bottom, min, mm			
J Distance to top, max, mm			
Stem enlargement:			
K OD, mm	35 ^T	35 ^T	35 ^T
L Length, mm			
M Distance to bottom, mm			

^o Capillary clearances shall conform to Section 8.

^T Mercury shall be near the bottom of the chamber at 0°C.

TABLE 1 Continued

ASTM No.	43C-86	43F-86 ^{FF}	44C-86	44F-86 ^{FF}	45C-86	45F-86 ^{FF}
IP No.	65C		29C		30C	
Name	Kinematic Viscosity ^{M,R}		Kinematic Viscosity ^M		Kinematic Viscosity ^M	
Reference Fig. No.						
Range	-51.6 to -34°C	-61 to -29°F	18.6 to 21.4°C	66.5 to 71.5°F	23.6 to 26.4°C	74.5 to 79.5°F
For test at			20°C	68 and 70°F	25°C	77°F
A Immersion, mm						
Graduations:						
Subdivisions	0.1°C	0.2°F	0.05°C	0.1°F	0.05°C	0.1°F
Long lines at each	0.5 and 1°C	1°F	0.1 and 0.5°C	0.5 and 1°F	0.1 and 0.5°C	0.5 and 1°F
Numbers at each	1°C starting at -51°C	2°F starting at -60°F	1°C	1°F	1°C	1°F
Scale error, max	0.1°C	0.2°F	0.1°C	0.2°F	0.1°C	0.2°F
Special inscription	ASTM 43C-86 or 43F-86 MERC-THAL		ASTM 44C-86 or 44F-86		ASTM 45C-86 or 45F-86	
Expansion chamber:						
Permit heating to		220°F ^S		220°F		220°F
B Total length, mm	105°C ^S		105°C		105°C	
C Stem OD, mm	410 to 425		300 to 310		300 to 310	
D Bulb length, mm	7.0 to 8.0		6.0 to 8.0		6.0 to 8.0	
E Bulb OD, mm	30 to 40		45 to 55		45 to 55	
Scale location:	6.0 to 7.0		>stem		>stem	
F Bottom of bulb to line at		-61°F				
G Distance, mm	-51.6°C		18.6°C		23.6°C	74.5°F
G Length of graduated portion, mm	60 to 90		145 to 165		145 to 165	
Ice-Point scale:	140 to 225 ^O		40 to 90 ^O		40 to 90 ^O	
Range	-0.6 to +0.6°C ^O	31 to 33°F ^O	-0.3 to +0.3°C ^O	31.5 to 32.5°F ^O	-0.3 to +0.3°C ^O	31.5 to 32.5°F ^O
H Bottom of bulb to ice-point, mm						
Contraction chamber:						
I Distance to bottom, min, mm		290 ^U		100		100
J Distance to top, max, mm		310 ^U		125		125
K Stem enlargement:						
L OD, mm						
L Length, mm						
M Distance to bottom, mm						

^M For kinematic viscosity thermometers, the ice-point reading shall be taken within 1 h after being at the test temperature for not less than 3 minutes. The ice-point reading shall be expressed to the nearest 0.01°C or 0.02°F and applied as explained in Test Method E 77, Section 13.

^O Capillary clearances shall conform to Section 8.

^R A suitable mercury-thallium alloy shall be used as the actuating liquid.

^S The expansion chamber shall be of the long narrow type 10 to 20 mm in length. The length of unchanged capillary between the nearest graduation mark and the expansion chamber shall be not less than 10 mm.

^U The length of unchanged capillary between the nearest graduation mark and contraction chamber shall be not less than 10 mm.

^{FF} For Fahrenheit thermometers, dimension G (length of graduated portion) shall be measured as the length of graduated portion corresponding to the nominal Celsius range.

TABLE 1 Continued

ASTM No.	46F-86 ^{FF}	47C-86	47F-86 ^{FF}	48C-86	48F-86 ^{FF}
IP No.	66C	35C	90C		
Name	Kinematic Viscosity ^M	Kinematic Viscosity ^M	Kinematic Viscosity ^M	Kinematic Viscosity ^M	Kinematic Viscosity ^M
Reference Fig. No.	6	6	6	6	6
Range	48.6 to 51.4°C 50°C	58.6 to 61.4°C 60°C	137.5 to 142.5°F 140°F	80.6 to 83.4°C 82.2°C	177.5 to 182.5°F 180°F
For test at	119.5 to 124.5°F 122°F	119.5 to 124.5°F 122°F	137.5 to 142.5°F 140°F	80.6 to 83.4°C 82.2°C	177.5 to 182.5°F 180°F
A Immersion, mm	total	total	total	total	total
Graduations:					
Subdivisions	0.05°C	0.05°C	0.1°F	0.05°C	0.1°F
Long lines at each	0.1 and 0.5°C	0.1 and 0.5°C	0.5 and 1°F	0.1 and 0.5°C	0.5 and 1°F
Numbers at each	1°C	1°C	1°F	1°C	1°F
Scale error, max	0.1°C	0.1°C	0.2°F	0.1°C	0.2°F
Special inscription	ASTM 46C-86 or 46F-86	ASTM 47C-86 or 47F-86	ASTM 47C-86 or 47F-86	ASTM 48C-86 or 48F-86	ASTM 48C-86 or 48F-86
Expansion chamber:					
Permit heating to	105°C	105°C	220°F	105°C	220°F
B Total length, mm	300 to 310	300 to 310	300 to 310	300 to 310	300 to 310
C Stem OD, mm	6.0 to 8.0	6.0 to 8.0	6.0 to 8.0	6.0 to 8.0	6.0 to 8.0
D Bulb length, mm	45 to 55	45 to 55	45 to 55	45 to 55	45 to 55
E Bulb OD, mm	>stem	>stem	>stem	>stem	>stem
Scale location:					
Bottom of bulb to line at	48.6°C	58.6°C	119.5°F	80.6°C	177.5°F
F Distance, mm	145 to 165	145 to 165	145 to 165	145 to 165	145 to 165
G Length of graduated portion, mm	40 to 90 ^o	40 to 90 ^o	40 to 90 ^o	40 to 90 ^o	40 to 90 ^o
Ice-point scale:					
Range	-0.3 to +0.3°C ^o	-0.3 to +0.3°C ^o	31.5 to 32.5°F ^o	-0.3 to +0.3°C ^o	31.5 to 32.5°F ^o
H Bottom of bulb to ice-point, mm					
Contraction chamber:					
I Distance to bottom, min, mm	100	100	100	100	100
J Distance to top, max, mm	125	125	125	125	125
K Stem enlargement:					
L OD, mm					
M Length, mm					
N Distance to bottom, mm					

^M For kinematic viscosity thermometers, the ice-point reading shall be taken within 1 h after being at the test temperature for not less than 3 minutes. The ice-point reading shall be expressed to the nearest 0.01°C or 0.02°F and applied as explained in Test Method E 77, Section 13.

^o Capillary clearances shall conform to Section 8.

^{FF} For Fahrenheit thermometers, dimension G (length of graduated portion) shall be measured as the length of graduated portion corresponding to the nominal Celsius range.

TABLE 1 Continued

IP No.	ASTM No.	49C-86	50F-86 ^{FF}	51F-86 ^{FF}
Name				
Reference Fig. No.				
Range				
For test at				
A Immersion, mm				
Graduations:				
Subdivisions				
Long lines at each				
Numbers at each				
Scale error, max				
Special inscription				
Expansion chamber:				
Permit heating to				
B Total length, mm				
C Stem OD, mm				
D Bulb length, mm				
E Bulb OD, mm				
Scale location:				
Bottom of bulb to line at				
F Distance, mm				
G Length of graduated portion, mm				
Ice-point scale:				
Range				
H Bottom of bulb to ice-point, mm				
Contraction chamber:				
I Distance to bottom, min, mm				
J Distance to top, max, mm				
Stem enlargement:				
K OD, mm				
L Length, mm				
M Distance to bottom, mm				
Stormer Viscosity				
7				
20 to 70°C				
65				
0.2°C				
1°C				
2°C				
0.2°C				
ASTM				
49C-86				
65 MM IMM				
100°C				
300 to 310				
5.5 to 6.0				
15 to 30				
←5.0 and →stem				
20°C				
70 to 80				
165 to 200 ^O				
Gas Calorimeter Inlet				
9				
54 to 101°F				
total				
0.1°F				
0.5°F				
1°F				
0.2°F ^V				
ASTM				
50F-86				
150°F				
463 to 473				
6.0 to 7.0				
25 to 30				
6.5 to 7.0				
54°F				
100 to 120				
292 to 338 ^O				
43 ^X				
Gas Calorimeter Outlet				
9				
69 to 116°F				
total				
0.1°F				
0.5°F				
1°F				
0.2°F ^V				
ASTM				
51F-86				
212°F				
463 to 473				
6.0 to 7.0				
25 to 30				
6.5 to 7.0				
69°F				
100 to 120				
292 to 338 ^O				
43 ^X				

^O Capillary clearances shall conform to Section 8.

^P Mercury shall be near middle of chamber at 0°C.

^V Change in correction over any 5°F interval shall not exceed 0.10°F.

^X Mercury shall be in the chamber at 32°F.

^{FF} For Fahrenheit thermometers, dimension G (length of graduated portion) shall be measured as the length of graduated portion corresponding to the nominal Celsius range.

TABLE 1 Continued

ASTM No.	52C-86	54C-86	54F-86 ^{FF}	56C-86	56F-86 ^{FF}
IP No.		18C			
Name	Butadiene Boiling Point Range		Congealing Point		Bomb Calorimeter
Reference Fig. No.	4		4		9
Range	-10 to +5°C	20 to 100.6°C	68 to 213°F	19 to 35°C	66 to 95°F
For test at	total	total	total		total
A Immersion, mm	0.1°C	0.2°C	0.5°F	0.02°C	0.05°F
Graduations:	0.5°C	1°C	1°F	0.1°C	0.1 and 0.5°F
Long lines at each	1°C	2°C	5°F	0.2°C	1°F
Numbers at each	0.1°C	0.2°C	0.5°F	0.10°C ^Y	0.20°F ^Z
Scale error, max	ASTM	ASTM	ASTM		ASTM
Special inscription	52C-86	54C-86 or 54F-86		56C-86 or 56F-86	
Expansion chamber:					
Permit heating to	100°C ^W	110°C	230°F	66°C	150°F
B Total length, mm	157 to 167				570 to 600
C Stem OD, mm	6.0 to 6.5				7.0 to 8.0
D Bulb length, mm	9 to 13				35 to 55
E Bulb OD, mm	5.5 to \rightarrow stem				7.0 to 8.0 ^{BB}
Scale location:					
Bottom of bulb to line at	-10°C	20°C	68°F	19°C	66°F
F Distance, mm	28 to 36				165 to 187
G Length of graduated portion, mm	70 to 100 ^O				323 to 385 ^O
Ice-point scale:					
Range					
H Bottom of bulb to ice-point, mm					
Contraction chamber:					
I Distance to bottom, min, mm					
J Distance to top, max, mm					
Stem enlargement:					
K OD, mm					
L Length, mm					
M Distance to bottom, mm					76

^O Capillary clearances shall conform to Section 8.

^W Expansion chamber shall be of the long narrow type and there shall be not less than 10 mm of unchanged capillary between the base of the chamber and the top graduation.

^Y Over any interval of 2°C the change in correction shall not exceed 0.02°C.

^Z Over any interval of 4°F the change in correction shall not exceed 0.05°F.

^{BB} The bulb diameter shall not be more than 0.5 mm greater than the stem.

^{FF} For Fahrenheit thermometers, dimension G (length of graduated portion) shall be measured as the length of graduated portion corresponding to the nominal Celsius range.

^{MM} Bulb shape ellipsoidal (see Fig. 2).

TABLE 1 Continued

IP	ASTM No.	66C-86	66F-86 ^{FF}	67C-86	67F-86 ^{FF}	68C-86	68F-86 ^{FF}
Name							
Reference Fig. No.							
Range							
For test at							
A Immersion, mm		75 to 105°C	167 to 221°F	95 to 155°C	203 to 311°F	145 to 205°C	293 to 401°F
Graduations:							
Subdivisions		0.1°C	0.2°F	0.2°C	0.5°F	0.2°C	0.5°F
Long lines at each		0.5°C	1°F	1°C	1°F	1°C	1°F
Numbers at each		1°C	2°F	2°C	5°F	2°C	5°F
Scale error, max		0.1°C	0.2°F	0.2°C	0.5°F	0.2°C	0.5°F
Special inscription		ASTM 66C-86 or 66F-86		ASTM 67C-86 or 67F-86		ASTM 68C-86 or 68F-86	
Expansion chamber:							
Permit heating to							
B Total length, mm		155°C	310°F	180°C	355°F	230°C	445°F
C Stem OD, mm							
D Bulb length, mm							
E Bulb OD, mm							
Scale location:							
Bottom of bulb to line at		75°C	167°F	95°C	203°F	145°C	293°F
F Distance, mm							
G Length of graduated portion, mm							
Ice-point scale:							
Range		-0.5 to +0.5°C ^o	31 to 33°F ^o	-1 to +1°C ^o	30 to 34°F ^o	-1 to +1°C ^o	30 to 34°F ^o
H Bottom of bulb to ice-point, mm							
Contraction chamber:							
I Distance to bottom, min, mm							
J Distance to top, max, mm							
Stem enlargement:							
K OD, mm							
L Length, mm							
M Distance to bottom, mm							
Precision							
6							
total							
ASTM							
66C-86 or 66F-86							
67C-86 or 67F-86							
68C-86 or 68F-86							

^o Capillary clearances shall conform to Section 8.

^{FF} For Fahrenheit thermometers, dimension G (length of graduated portion) shall be measured as the length of graduated portion corresponding to the nominal Celsius range.

TABLE 1 Continued

IP No.	ASTM No.	69C-86	69F-86 ^{FF}	70C-86	70F-86 ^{FF}	71C-86	71F-86 ^{FF}
Name						72C	
Reference Fig. No.							Oil in Wax 3
Range							-35 to +70°F
For test at							
A		195 to 305°C	383 to 581°F	295 to 405°C ^C	563 to 761°F ^C	-37 to +21°C	
Immersion, mm				total			76
Graduations:							
Subdivisions		0.5°C	1°F	0.5°C	1°F	0.5°C	1°F
Long lines at each		1°C	5°F	1°C	5°F	1°C	5°F
Numbers at each		5°C	10°F	5°C	10°F	5°C	10°F
Scale error, max		0.5°C	1°F	0.5°C	1°F	0.2°C	0.5°F
Special inscription				ASTM			ASTM
		69C-86 or 69F-86		70C-86 or 70F-86		71C-86 or 71F-86	76 MM IMM
Expansion chamber:							
Permit heating to							
B		330°C	625°F			105°C	220°F
Total length, mm							
C							350 to 360
Stem OD, mm							6.0 to 8.0
Bulb length, mm							15 to 20
D							6.0 to 7.0
Bulb OD, mm							
E							
Scale location:							
Bottom of bulb to line at							
F		195°C	383°F	295°C	563°F	-37°C	-35°F
Distance, mm							
G							170 to 185
Length of graduated portion, mm							105 to 140 ^O
Ice-point scale:							
Range		-2 to +2°C ^O	27 to 37°F ^O	-2 to +2°C ^O	27 to 37°F ^O		
H							
Bottom of bulb to ice-point, mm							
Contraction chamber:							
I							
Distance to bottom, min, mm							
J							
Distance to top, max, mm							
K							
Stem enlargement:							
OD, mm							
L							
Length, mm							
M							
Distance to bottom, mm							

^A An expansion chamber is provided for relief of gas pressure to avoid distortion of the bulb at higher temperatures. It is not for the purpose of joining mercury separations and under no circumstances should the thermometer be heated above the highest temperature reading.

^C Under certain test conditions, the bulb of the thermometer may be 28°C (50°F) above the temperature indicated by the thermometer, and at an indicated temperature of 371°C (700°F) the temperature of the bulb is approaching a critical range in the glass. It is therefore not desirable to use this thermometer under such conditions at indicated temperatures above 371°C (700°F) without checking the ice point.

^O Capillary clearances shall conform to Section 8.

^{FF} For Fahrenheit thermometers, dimension G (length of graduated portion) shall be measured as the length of graduated portion corresponding to the nominal Celsius range.

TABLE 1 Continued

ASTM No.	72C-86	72F-86 ^{FF}	73C-86	73F-86 ^{FF}	74C-86	74F-86 ^{FF}
IP No.	67C	67C	68C	68C	69C	69C
Name	Kinematic Viscosity ^M	Kinematic Viscosity ^{M,R}	Kinematic Viscosity ^{M,R}	Kinematic Viscosity ^{M,R}	Kinematic Viscosity ^{M,R}	Kinematic Viscosity ^{M,R}
Reference Fig. No.	10	10	10	10	10	10
Range	-19.4 to -16.6°C -17.8°C	-2.5 to +2.5°F 0°F	-41.4 to -38.6°C -40°C	-42.5 to -37.5°F -40°F	-55.4 to -52.6°C -53.9°C	-67.5 to -62.5°F -65°F
For test at						
A Immersion, mm	0.05°C	0.1°F	0.05°C	0.1°F	0.05°C	0.1°F
Graduations:					total	total
Long lines at each	0.1 and 0.5°C	0.5 and 1°F	0.1 and 0.5°C	0.5 and 1°F	0.1 and 0.5°C	0.5 and 1°F
Numbers at each	1°C	1°F	1°C	1°F	1°C	1°F
Scale error, max	0.1°C	0.2°F	0.1°C	0.2°F	0.1°C	0.2°F
Special inscription	ASTM 72C-86 or 72F-86		ASTM 73C-86 or 73F-86 MERC-THAL		ASTM 74C-86 or 74F-86 MERC-THAL	
Expansion chamber:						
Permit heating to						
B Total length, mm	105°C	220°F	105°C	220°F	105°C	220°F
C Stem OD, mm	300 to 310		300 to 310		300 to 310	
D Bulb length, mm	6.0 to 8.0		6.0 to 8.0		6.0 to 8.0	
E Bulb OD, mm	45 to 55		45 to 55		45 to 55	
Scale location:						
Bottom of bulb to line at						
F Distance, mm	-19.4°C	-2.5°F	-41.4°C	-42.5°F	-55.4°C	-67.5°F
G Length of graduated portion, mm	80 to 110		80 to 110		80 to 110	
Ice-point scale:						
Range	-0.3 to +0.3°C ^O	31.5 to 32.5°F ^O	-0.3 to +0.3°C ^O	31.5 to 32.5°F ^O	-0.3 to +0.3°C ^O	31.5 to 32.5°F ^O
H Bottom of bulb to ice-point, mm						
Contraction chamber:						
I Distance to bottom, min, mm	180		180		180	
J Distance to top, max, mm	205		205		205	
Stem enlargement:						
K OD, mm						
L Length, mm						
M Distance to bottom, mm						

^O Capillary clearances shall conform to Section 8.

^M For kinematic viscosity thermometers, the ice-point reading shall be taken within 1 h after being at the test temperature for not less than 3 minutes. The ice-point reading shall be expressed to the nearest 0.01°C or 0.02°F and applied as explained in Test Method E 77, Section 13.

^R A suitable mercury-thallium alloy shall be used as the actuating liquid.

^{FF} For Fahrenheit thermometers, dimension G (length of graduated portion) shall be measured as the length of graduated portion corresponding to the nominal Celsius range.

TABLE 1 Continued

	ASTM No.	75F-86 ^{FF}	76F-86 ^{FF}	77F-86 ^{FF}
IP No.				
Name				
Reference Fig. No.				
Range				
For test at				
A Immersion, mm				
Graduations:				
Subdivisions				
Long lines at each				
Numbers at each				
Scale error, max				
Special inscription				
Expansion chamber:				
Permit heating to				
B Total length, mm				
C Stem OD, mm				
D Bulb length, mm				
E Bulb OD, mm				
Scale location:				
Bottom of bulb to line at				
F Distance, mm				
G Length of graduated portion, mm				
Ice-point scale:				
Range				
H Bottom of bulb to ice-point, mm				
Contraction chamber:				
I Distance to bottom, min, mm				
J Distance to top, max, mm				
Stem enlargement:				
K OD, mm				
L Length, mm				
M Distance to bottom, mm				
Coolant (Antifreeze) Freezing Point				
3				
-35 to +35°F				
100				
0.5°F				
1°F				
5°F				
0.5°F				
1°F				
ASTM				
75F-86				
100 MM IMM				
140°F				
403 to 413				
6.0 to 7.0				
20 to 30				
5.0 to 6.0				
-65°F				
200 to 230				
116 to 162 ^o				
Coolant (Antifreeze) Freezing Point ^R				
3				
-65 to +5°F				
100				
0.5°F				
1°F				
5°F				
1°F				
ASTM				
76F-86				
100 MM IMM				
MERC-THAL				
140°F				
403 to 413				
6.0 to 7.0				
20 to 30				
5.0 to 6.0				
-65°F				
200 to 230				
116 to 162 ^o				
Saybolt Viscosity				
8				
245 to 265°F				
250°F ^G				
total				
0.5°F				
1°F				
5°F				
0.5°F				
ASTM				
77F-86				
315°F				
270 to 280				
6.0 to 7.0				
25 to 35				
<5.0 and >stem				
245°F				
135 to 150				
67 to 101 ^o				
60 ^H				
8.0 to 10.0				
4.0 to 7.0				
112 to 116				

^G The test temperature shall be indicated by an arrow whether the graduation corresponding to that point is numbered or not.

^H Long, narrow shape; mercury shall be in the chamber at 0°C (32°F).

^O Capillary clearances shall conform to Section 8.

^R A suitable mercury-thallium alloy shall be used as the actuating liquid.

^{FF} For Fahrenheit thermometers, dimension G (length of graduated portion) shall be measured as the length of graduated portion corresponding to the nominal Celsius range.

TABLE 1 Continued

ASTM No.	78F-86 ^{FF}	79F-86 ^{FF}	80F-86 ^{FF}
IP No.			
Name	Saybolt Viscosity	Saybolt Viscosity	Saybolt Viscosity
Reference Fig. No.	8	8	8
Range	295 to 315°F	345 to 365°F	395 to 415°F
For test at	300°F ^G	350°F ^G	400°F ^G
A Immersion, mm	total	total	total
Graduations:			
Subdivisions	0.5°F	0.5°F	0.5°F
Long lines at each	1°F	1°F	1°F
Numbers at each	5°F	5°F	5°F
Scale error, max	0.5°F	0.5°F	0.5°F
Special inscription	ASTM	ASTM	ASTM
	78F-86	79F-86	80F-86
Expansion chamber:			
Permit heating to	365°F	415°F	465°F
B Total length, mm	270 to 280	270 to 280	270 to 280
C Stem OD, mm	6.0 to 7.0	6.0 to 7.0	6.0 to 7.0
D Bulb length, mm	25 to 35	25 to 35	25 to 35
E Bulb OD, mm	<5.0 and >stem	<5.0 and >stem	<5.0 and >stem
Scale location:			
Bottom of bulb to line at	295°F	345°F	395°F
F Distance, mm	135 to 150	135 to 150	135 to 150
G Length of graduated portion, mm	67 to 101 ^o	67 to 101 ^o	67 to 101 ^o
Ice-point scale:			
Range			
H Bottom of bulb to ice-point, mm			
Contraction chamber:			
I Distance to bottom, min, mm	60 ^H	60 ^H	60 ^H
J Distance to top, max, mm			
Stem enlargement:			
K OD, mm	8.0 to 10.0	8.0 to 10.0	8.0 to 10.0
L Length, mm	4.0 to 7.0	4.0 to 7.0	4.0 to 7.0
M Distance to bottom, mm	112 to 116	112 to 116	112 to 116

^G The test temperature shall be indicated by an arrow whether the graduation corresponding to that point is numbered or not.

^H Long, narrow shape; mercury shall be in the chamber at 0°C (32°F).

^o Capillary clearances shall conform to Section 8.

^{FF} For Fahrenheit thermometers, dimension G (length of graduated portion) shall be measured as the length of graduated portion corresponding to the nominal Celsius range.

TABLE 1 Continued

	ASTM No.	81F-86 ^{FF}	82C-86	82F-86 ^{FF}	83C-03	83F-03 ^{FF}
IP No.						
Name		Saybolt Viscosity		Fuel Rating Engine		Fuel Rating Air-Low
Reference Fig. No.		8		11		11
Range		445 to 465°F		0 to 220°F		60 to 160°F
For test at		450°F ^G	-15 to +105°C		15 to 70°C	125°F and 150°F ^G
A	Immersion, mm	total		30 ^{EE}		40 ^{EE}
	Graduations:					
	Subdivisions	0.5°F	1°C	2°F	1°C	1°F
	Long lines at each	1°F	5°C	10°F	5°C	5°F
	Numbers at each	5°F	10°C	20°F	10°C	10°F
	Scale error, max	0.5°F	1°C	2°F	1°C	2°F
	Special inscription	ASTM		ASTM		ASTM
		81F-86		82C-86 or 82F-86		83C-03 or 83F-03
				30 MM IMM		40 MM IMM
	Expansion chamber:					
	Permit heating to	515°F	125°C	260°F	100°C	215°F
B	Total length, mm	270 to 280		159 to 165		168 to 174
C	Stem OD, mm	6.0 to 7.0		6.0 to 7.0		6.0 to 7.0
D	Bulb length, mm	25 to 35		6 to 11		6 to 11
E	Bulb OD, mm	≤5.0 and ≥stem		5.0 to 6.5		5.0 to 6.5
	Scale location:					
	Bottom of bulb to line at	445°F	-15°C	0°F	15°C	60°F
F	Distance, mm	135 to 150		62 to 70		71 to 78
G	Length of graduated portion, mm	67 to 101 ^o		65 to 81 ^o		64 to 81 ^o
	Ice-point scale:					
	Range					
H	Bottom of bulb to ice-point, mm					
	Contraction chamber:					
I	Distance to bottom, min, mm					
J	Distance to top, max, mm	60 ^H				
	Stem enlargement:					
K	OD, mm	8.0 to 10.0		8.0 to 9.0		8.0 to 9.0
L	Length, mm	4.0 to 7.0				
M	Distance to bottom, mm	112 to 116		28 to 32		38 to 42

^G The test temperature shall be indicated by an arrow whether the graduation corresponding to that point is numbered or not.

^H Long, narrow shape; mercury shall be in the chamber at 0°C (32°F).

^o Capillary clearances shall conform to Section 8.

^{EE} Immersion line shall be omitted.

^{FF} For Fahrenheit thermometers, dimension G (length of graduated portion) shall be measured as the length of graduated portion corresponding to the nominal Celsius range.

TABLE 1 Continued

ASTM No.	84C-86	84F-86 ^{FF}	85C-86	85F-86 ^{FF}	86C-86	86F-86 ^{FF}
IP No.						
Name						
Reference Fig. No.						
Range	25 to 80°C	75 to 175°F	40 to 150°C	100 to 300°F	95 to 175°C	200 to 350°F
For test at	51.7°C ^G	125°F ^G	107.2°C ^G	225°F ^G	104.4°C and 148.9°C ^G	220°F and 300°F ^G
A Immersion, mm		249 ^{EE}		181 ^{EE}		35 ^{EE}
Graduations:						
Subdivisions	1°C	1°F	1°C	2°F	1°C	2°F
Long lines at each	5°C	5°F	5°C	10°F	5°C	10°F
Numbers at each	10°C	10°F	10°C	20°F	10°C	20°F
Scale error, max	1°C	2°F	1°C	2°F	1°C	2°F
Special inscription		ASTM		ASTM		ASTM
		84C-86 or 84F-86		85C-86 or 85F-86		86C-86 or 86F-86
		249 IMM IMM		181 IMM IMM		35 IMM IMM
Expansion chamber:						
Permit heating to	100°C	215°F	170°C	340°F	195°C	390°F
B Total length, mm		378 to 387		305 to 314		164 to 170
C Stem OD, mm		6.0 to 7.0		6.0 to 7.0		6.0 to 7.0
D Bulb length, mm		6 to 11		6 to 11		6 to 11
E Bulb OD, mm		5.0 to 6.5		5.0 to 6.5		5.0 to 6.5
Scale location:						
Bottom of bulb to line at	25°C	75°F	40°C	100°F	95°C	200°F
F Distance, mm		284 to 292		213 to 221		67 to 75
G Length of graduated portion, mm		62 to 79 ^O		54 to 77 ^O		58 to 81 ^O
Ice-point scale:						
Range						
H Bottom of bulb to ice-point, mm						
Contraction chamber:						
J Distance to bottom, min, mm						
J Distance to top, max, mm						
Stem enlargement:						
K OD, mm		8.0 to 9.0		8.0 to 9.0		8.0 to 9.0
L Length, mm						
M Distance to bottom, mm		247 to 251		179 to 183		33 to 37

^O Capillary clearances shall conform to Section 8.

^{EE} Immersion line shall be omitted.

^{FF} For Fahrenheit thermometers, dimension G (length of graduated portion) shall be measured as the length of graduated portion corresponding to the nominal Celsius range.

TABLE 1 Continued

ASTM No.	87C-86	87F-86 ^{FF}	88C-86	88F-86 ^{FF}	89C-86
IP No.					
Name					
Reference Fig. No.					
Range					
For test at					
A Immersion, mm	150 to 205°C 190.6°C ^G	300 to 400°F 375°F ^G	10 to 200°C	50 to 392°F	3 -20 to + 10°C
Graduations:					
Subdivisions	1°C	1°F	1°C	2°F	76
Long lines at each	5°C	5°F	5°C	10°F	0.1°C
Numbers at each	10°C	10°F	10°C	20°F	0.5°C
Scale error, max	1°C	2°F	1°C	2°F	1.0°C
Special inscription		ASTM			0.1°C
		87C-86 or 87F-86	88C-86 or 88F-86		ASTM
		40 MM IMM	57 MM IMM		89C-86
Expansion chamber:					76 MM IMM
Permit heating to					
B Total length, mm	225°C	440°F	250°C	490°F	60°C
C Stem OD, mm		169 to 175			365 to 375
D Bulb length, mm		6.0 to 7.0			6.0 to 7.0
E Bulb OD, mm		6 to 11			18 to 28
Scale location:		5.0 to 6.5			<5.0 and >stem
Bottom of bulb to line at					
F Distance, mm	150°C	300°F	10°C	50°F	-20°C
G Length of graduated portion, mm		72 to 80			116 to 130
Ice-point scale:		59 to 82 ^O			185 to 219 ^O
Range					
H Bottom of bulb to ice-point, mm					
Contraction chamber:					
I Distance to bottom, min, mm		21			
J Distance to top, max, mm					
Stem enlargement:					
K OD, mm		8.0 to 9.0			7.5 to 8.5 ^E
L Length, mm		38 to 42			2.5 to 5.0
M Distance to bottom, mm					64 to 66

^E The length of the enlargement, and the distance from the bottom of the enlargement to the bottom of the bulb shall be measured with the test gage shown in Fig. 1.

^O Capillary clearances shall conform to Section 8.

^{EE} Immersion line shall be omitted.

^{FF} For Fahrenheit thermometers, dimension G (length of graduated portion) shall be measured as the length of graduated portion corresponding to the nominal Celsius range.

TABLE 1 Continued

ASTM No.	90C-86	91C-86	92C-86
IP No.			
Name			
Reference Fig. No.			
Range	Solidification Point 3 0 to 30°C	Solidification Point 7 20 to 50°C	Solidification Point 7 40 to 70°C
For test at			
A Immersion, mm	76	76	76
Graduations:			
Subdivisions	0.1°C	0.1°C	0.1°C
Long lines at each	0.5°C	0.5°C	0.5°C
Numbers at each	1.0°C	1.0°C	1.0°C
Scale error, max	0.1°C	0.1°C	0.1°C
Special inscription	ASTM 90C-86 76 MM IMM	ASTM 91C-86 76 MM IMM	ASTM 92C-86 76 MM IMM
Expansion chamber:			
Permit heating to	80°C	100°C	110°C
B Total length, mm	365 to 375	365 to 375	365 to 375
C Stem OD, mm	6.0 to 7.0	6.0 to 7.0	6.0 to 7.0
D Bulb length, mm	18 to 28	18 to 28	18 to 28
E Bulb OD, mm	≤5.0 and ≥stem	≤5.0 and ≥stem	≤5.0 and ≥stem
Scale location:			
Bottom of bulb to line at	0°C	20°C	40°C
F Distance, mm	116 to 130	116 to 130	116 to 130
G Length of graduated portion, mm	185 to 219 ^o	185 to 219 ^o	185 to 219 ^o
Ice-point scale:			
Range			
H Bottom of bulb to ice-point, mm			
Contraction chamber:			
I Distance to bottom, min, mm			
J Distance to top, max, mm			
Stem enlargement:			
K OD, mm			
L Length, mm			
M Distance to bottom, mm		41	41

^o Capillary clearances shall conform to Section 8.

TABLE 1 Continued

ASTM No.	93C-86	94C-86	95C-86
IP No.			
Name			
Reference Fig. No.			
Range	Solidification Point 7 60 to 90°C	Solidification Point 7 80 to 110°C	Solidification Point 7 100 to 130°C
For test at			
A Immersion, mm	76	76	76
Graduations:			
Subdivisions	0.1°C	0.1°C	0.1°C
Long lines at each	0.5°C	0.5°C	0.5°C
Numbers at each	1.0°C	1.0°C	1.0°C
Scale error, max	0.1°C	0.1°C	0.2°C
Special inscription	ASTM 93C-86 76 MM IMM	ASTM 94C-86 76 MM IMM	ASTM 95C-86 76 MM IMM
Expansion chamber:			
Permit heating to	130°C	150°C	170°C
B Total length, mm	365 to 375	365 to 375	365 to 375
C Stem OD, mm	6.0 to 7.0	6.0 to 7.0	6.0 to 7.0
D Bulb length, mm	18 to 28	18 to 28	18 to 28
E Bulb OD, mm	≤5.0 and ≥stem	≤5.0 and ≥stem	≤5.0 and ≥stem
Scale location:			
Bottom of bulb to line at	60°C	80°C	100°C
F Distance, mm	116 to 130	116 to 130	116 to 130
G Length of graduated portion, mm	185 to 219 ^o	185 to 219 ^o	185 to 219 ^o
Ice-point scale:			
Range			
H Bottom of bulb to ice-point, mm			
Contraction chamber:			
I Distance to bottom, min, mm			
J Distance to top, max, mm	41	41	41
Stem enlargement:			
K OD, mm			
L Length, mm			
M Distance to bottom, mm			

^o Capillary clearances shall conform to Section 8.

TABLE 1 Continued

ASTM No.	96C-86	97C-86	97F-86 ^{FF}	98C-86	98F-86 ^{FF}
IP No.					
Name	Solidification Point				
Reference Fig. No.	7				
Range	120 to 150°C	-18 to +49°C	0 to 120°F	16 to 82°C	60 to 180°F
For test at					
A Immersion, mm	76				
Graduations:					
Subdivisions	0.1°C	0.5°C	1°F	0.5°C	1°F
Long lines at each	0.5°C	1°C	5°F	1°C	5°F
Numbers at each	1.0°C	5°C	10°F	5°C	10°F
Scale error, max	0.2°C	0.3°C	0.5°F	0.3°C	0.5°F
Special inscription	ASTM 96C-86 76 MM 1MM	ASTM 97C-86 or 97F-86	ASTM 98C-86 or 98F-86	ASTM 98C-86 or 98F-86	ASTM 98C-86 or 98F-86
Expansion chamber:					
Permit heating to	190°C	100°C	212°F	100°C	212°F
B Total length, mm	365 to 375				
C Stem OD, mm	6.0 to 7.0				
D Bulb length, mm	18 to 28				
E Bulb OD, mm	≤5.0 and ≥stem				
Scale location:					
Bottom of bulb to line at	120°C	-18°C	0°F	16°C	60°F
F Distance, mm	116 to 130				
G Length of graduated portion, mm	185 to 219 ^o				
Ice-point scale:					
Range					
H Bottom of bulb to ice-point, mm					
Contraction chamber:					
I Distance to bottom, min, mm					
J Distance to top, max, mm	41				
Stem enlargement:					
K OD, mm					
L Length, mm					
M Distance to bottom, mm					
Tank					
4 ^{AA}					
total					
CC					
stem					

^o Capillary clearances shall conform to Section 8.

^{AA} Special finish, see 6.2.2.

^{CC} The stem shall be of the lens front type. The cross section of the stem shall be such that it will pass through a 8.0-mm ring gage but will not enter a 5.0-mm slot gage. A minor diameter of 4 mm is permissible provided that the major diameter is not less than 7 mm.

^{FF} For Fahrenheit thermometers, dimension G (length of graduated portion) shall be measured as the length of graduated portion corresponding to the nominal Celsius range.

TABLE 1 Continued

ASTM No.	99C-92	99F-86 ^{FF}	100C-86	101C-86
IP No.				
Name				
Reference Fig. No.				
Range				
For test at				
A Immersion, mm				
Graduations:				
Subdivisions				
Long lines at each				
Numbers at each				
Scale error, max				
Special inscription				
Expansion chamber:				
Permit heating to				
B Total length, mm				
C Stem OD, mm				
D Bulb length, mm				
E Bulb OD, mm				
Scale location:				
Bottom of bulb to line at				
Distance, mm				
G Length of graduated portion, mm				
Ice-point scale:				
Range				
Bottom of bulb to ice-point, mm				
I Contraction chamber:				
Distance to bottom, min, mm				
Distance to top, max, mm				
K Stem enlargement:				
OD, mm				
L Length, mm				
M Distance to bottom, mm				
Weathering Test ^R				
3 ^{AA}				
35 ^{GG}				
Solidification Point				
7				
195 to 305°C				
76				
0.5°C				
1°C				
5°C				
1.0°C				
ASTM				
101C-86				
76 MM IMM				
Solidification Point				
7				
145 to 205°C				
76				
0.2°C				
1°C				
2°C				
0.4°C				
ASTM				
100C-86				
76 MM IMM				
Solidification Point				
7				
145 to 205°C				
76				
0.2°C				
1°C				
5°C				
1.0°C				
ASTM				
101C-86				
76 MM IMM				
ASTM				
99C-92 or 99F-86				
35 MM IMM				
MERC-THAL				
ASTM				
99C-92 or 99F-86				
35 MM IMM				
MERC-THAL				
ASTM				
99C-92 or 99F-86				
35 MM IMM				
MERC-THAL				
ASTM				
99C-92 or 99F-86				
35 MM IMM				
MERC-THAL				
ASTM				
99C-92 or 99F-86				
35 MM IMM				
MERC-THAL				
ASTM				
99C-92 or 99F-86				
35 MM IMM				
MERC-THAL				
ASTM				
99C-92 or 99F-86				
35 MM IMM				
MERC-THAL				
ASTM				
99C-92 or 99F-86				
35 MM IMM				
MERC-THAL				
ASTM				
99C-92 or 99F-86				
35 MM IMM				
MERC-THAL				
ASTM				
99C-92 or 99F-86				
35 MM IMM				
MERC-THAL				
ASTM				
99C-92 or 99F-86				
35 MM IMM				
MERC-THAL				
ASTM				
99C-92 or 99F-86				
35 MM IMM				
MERC-THAL				
ASTM				
99C-92 or 99F-86				
35 MM IMM				
MERC-THAL				
ASTM				
99C-92 or 99F-86				
35 MM IMM				
MERC-THAL				
ASTM				
99C-92 or 99F-86				
35 MM IMM				
MERC-THAL				
ASTM				
99C-92 or 99F-86				
35 MM IMM				
MERC-THAL				
ASTM				
99C-92 or 99F-86				
35 MM IMM				
MERC-THAL				
ASTM				
99C-92 or 99F-86				
35 MM IMM				
MERC-THAL				
ASTM				
99C-92 or 99F-86				
35 MM IMM				
MERC-THAL				
ASTM				
99C-92 or 99F-86				
35 MM IMM				
MERC-THAL				
ASTM				
99C-92 or 99F-86				
35 MM IMM				
MERC-THAL				
ASTM				
99C-92 or 99F-86				
35 MM IMM				
MERC-THAL				
ASTM				
99C-92 or 99F-86				
35 MM IMM				
MERC-THAL				
ASTM				
99C-92 or 99F-86				
35 MM IMM				
MERC-THAL				
ASTM				
99C-92 or 99F-86				
35 MM IMM				
MERC-THAL				
ASTM				
99C-92 or 99F-86				
35 MM IMM				
MERC-THAL				
ASTM				
99C-92 or 99F-86				
35 MM IMM				
MERC-THAL				
ASTM				
99C-92 or 99F-86				
35 MM IMM				
MERC-THAL				
ASTM				
99C-92 or 99F-86				
35 MM IMM				
MERC-THAL				
ASTM				
99C-92 or 99F-86				
35 MM IMM				
MERC-THAL				
ASTM				
99C-92 or 99F-86				
35 MM IMM				
MERC-THAL				
ASTM				
99C-92 or 99F-86				
35 MM IMM				
MERC-THAL				
ASTM				
99C-92 or 99F-86				
35 MM IMM				
MERC-THAL				
ASTM				
99C-92 or 99F-86				
35 MM IMM				
MERC-THAL				
ASTM				
99C-92 or 99F-86				
35 MM IMM				
MERC-THAL				
ASTM				
99C-92 or 99F-86				
35 MM IMM				
MERC-THAL				
ASTM				
99C-92 or 99F-86				
35 MM IMM				
MERC-THAL				
ASTM				
99C-92 or 99F-86				
35 MM IMM				
MERC-THAL				
ASTM				
99C-92 or 99F-86				
35 MM IMM				
MERC-THAL				
ASTM				
99C-92 or 99F-86				
35 MM IMM				
MERC-THAL				
ASTM				
99C-92 or 99F-86				
35 MM IMM				
MERC-THAL				
ASTM				
99C-92 or 99F-86				
35 MM IMM				
MERC-THAL				
ASTM				
99C-92 or 99F-86				
35 MM IMM				
MERC-THAL				
ASTM				
99C-92 or 99F-86				
35 MM IMM				
MERC-THAL				
ASTM				
99C-92 or 99F-86				
35 MM IMM				
MERC-THAL				
ASTM				
99C-92 or 99F-86				
35 MM IMM				
MERC-THAL				
ASTM				
99C-92 or 99F-86				
35 MM IMM				
MERC-THAL				
ASTM				
99C-92 or 99F-86				
35 MM IMM				
MERC-THAL				
ASTM				
99C-92 or 99F-86				
35 MM IMM				
MERC-THAL				
ASTM				
99C-92 or 99F-86				
35 MM IMM				
MERC-THAL				
ASTM				
99C-92 or 99F-86				
35 MM IMM				
MERC-THAL				
ASTM				
99C-92 or 99F-86				
35 MM IMM				
MERC-THAL				
ASTM				
99C-92 or 99F-86				
35 MM IMM				
MERC-THAL				
ASTM				
99C-92 or 99F-86				
35 MM IMM				
MERC-THAL				
ASTM				
99C-92 or 99F-86				
35 MM IMM				
MERC-THAL				
ASTM				
99C-92 or 99F-86				
35 MM IMM				
MERC-THAL				
ASTM				
99C-92 or 99F-86				
35 MM IMM				
MERC-THAL				
ASTM				
99C-92 or 99F-86				
35 MM IMM				
MERC-THAL				
ASTM				
99C-92 or 99F-86				
35 MM IMM				
MERC-THAL				
ASTM				
99C-92 or 99F-86				
35 MM IMM				
MERC-THAL				
ASTM				
99C-92 or 99F-86				
35 MM IMM				
MERC-THAL				
ASTM				
99C-92 or 99F-86				
35 MM IMM				

TABLE 1 Continued

ASTM No.	102C-86	103C-86	104C-86
IP No.	83C	84C	85C
Name	Solvents Distillation	Solvents Distillation	Solvents Distillation
Reference Fig. No.	7	7	7
Range	123 to 177°C	148 to 202°C	173 to 227°C
For test at			
A Immersion, mm	100	100	100
Graduations:			
Subdivisions	0.2°C	0.2°C	0.2°C
Long lines at each	1°C	1°C	1°C
Numbers at each	2°C	2°C	2°C
Scale error, max	0.3°C	0.4°C	0.4°C
Special inscription	ASTM	ASTM	ASTM
	102C-86	103C-86	104C-86
	100 MM IMM	100 MM IMM	100 MM IMM
Expansion chamber:			
Permit heating to	200°C	225°C	250°C
B Total length, mm	390 to 400	390 to 400	390 to 400
C Stem OD, mm	6.0 to 8.0	6.0 to 8.0	6.0 to 8.0
D Bulb length, mm	15 to 20	15 to 20	15 to 20
E Bulb OD, mm	>stem	>stem	>stem
Scale location:			
F Bottom of bulb to line at	123°C	148°C	173°C
G Distance, mm	125 to 145	125 to 145	125 to 145
Length of graduated portion, mm	190 to 235 ^o	190 to 235 ^o	190 to 235 ^o
Ice-point scale:			
Range			
H Bottom of bulb to ice-point, mm			
Contraction chamber:			
I Distance to bottom, min, mm			
J Distance to top, max, mm	35 ^T	35 ^T	35 ^T
Stem enlargement:			
K OD, mm			
L Length, mm			
M Distance to bottom, mm			

^o Capillary clearances shall conform to Section 8.

^T Mercury shall be near the bottom of the chamber at 0°C.

TABLE 1 Continued

ASTM No.	105C-86	106C-86	107C-86
IP No.	86C	87C	88C
Name	Solvents Distillation	Solvents Distillation	Solvents Distillation
Reference Fig. No.	7	7	7
Range	198 to 252°C	223 to 277°C	248 to 302°C
For test at			
A Immersion, mm	100	100	100
Graduations:			
Subdivisions	0.2°C	0.2°C	0.2°C
Long lines at each	1°C	1°C	1°C
Numbers at each	2°C	2°C	2°C
Scale error, max	0.6°C	0.8°C	1.0°C
Special inscription	ASTM	ASTM	ASTM
	105C-86	106C-86	107C-86
	100 MM IMM	100 MM IMM	100 MM IMM
Expansion chamber:			
Permit heating to	275°C	300°C	325°C
B Total length, mm	390 to 400	390 to 400	390 to 400
C Stem OD, mm	6.0 to 8.0	6.0 to 8.0	6.0 to 8.0
D Bulb length, mm	15 to 20	15 to 20	15 to 20
E Bulb OD, mm	↗stem	↗stem	↗stem
Scale location:			
Bottom of bulb to line at	198°C	223°C	248°C
F Distance, mm	125 to 145	125 to 145	125 to 145
G Length of graduated portion, mm	190 to 235 ^o	190 to 235 ^o	190 to 235 ^o
Ice-point scale:			
Range			
H Bottom of bulb to ice-point, mm			
Contraction chamber:			
I Distance to bottom, min, mm			
J Distance to top, max, mm			
Stem enlargement:			
K OD, mm	35 ^T	35 ^T	35 ^T
L Length, mm			
M Distance to bottom, mm			

^o Capillary clearances shall conform to Section 8.

^T Mercury shall be near the bottom of the chamber at 0°C.

TABLE 1 Continued

ASTM No.	108F-86 ^{FF}	109F-86 ^{FF}	110C-86	110F-86 ^{FF}
IP No.			93C	
Name	Saybolt Viscosity	Saybolt Viscosity		Kinematic Viscosity ^M
Reference Fig. No.	8	8		6
Range	270 to 290°F	320 to 340°F	133.6 to 136.4°C	272.5 to 277.5°F
For test at	275°F ^G	325°F ^G	135°C	275°F
A Immersion, mm	total	total		total
Graduations:	0.5°F	0.5°F	0.05°C	0.1°F
Subdivisions	1°F	1°F	0.1 and 0.5°C	0.5 and 1°F
Long lines at each	5°F	5°F	1°C	1°F
Numbers at each	0.5°F	0.5°F	0.15°C	0.3°F
Scale error, max	ASTM	ASTM		ASTM
Special inscription	108F-86	109F-86		110C-86 or 110F-86
Expansion chamber:				
Permit heating to	340°F	390°F	170°C	350°F
B Total length, mm	270 to 280	270 to 280		300 to 310
C Stem OD, mm	6.0 to 7.0	6.0 to 7.0		6.0 to 8.0
D Bulb length, mm	25 to 35	25 to 35		45 to 55
E Bulb OD, mm	≤5.0 and ≥stem	≤5.0 and ≥stem		≥stem
Scale location:				
Bottom of bulb to line at	270°F	320°F	133.6°C	272.5°F
F Distance, mm	135 to 150	135 to 150		160 to 180
G Length of graduated portion, mm	67 to 101 ^O	67 to 101 ^O		40 to 90 ^O
Ice-point scale:				
Range			-0.3 to +0.6°C	31.5 to 33.0°F ^O
H Bottom of bulb to ice-point, mm				
Contraction chamber:				
I Distance to bottom, min, mm	60 ^H	60 ^H		100
J Distance to top, max, mm				125
K Stem enlargement:				
OD, mm	8.0 to 10.0	8.0 to 10.0		
L Length, mm	4.0 to 7.0	4.0 to 7.0		
M Distance to bottom, mm	112 to 116	112 to 116		

^G The test temperature shall be indicated by an arrow whether the graduation corresponding to that point is numbered or not.

^H Long, narrow shape; mercury shall be in the chamber at 0°C (32°F).

^M For kinematic viscosity thermometers, the ice-point reading shall be taken within 1 h after being at the test temperature for not less than 3 minutes. The ice-point reading shall be expressed to the nearest 0.01°C or 0.02°F and applied as explained in Test Method E 77, Section 13.

^O Capillary clearances shall conform to Section 8.

^{FF} For Fahrenheit thermometers, dimension G (length of graduated portion) shall be measured as the length of graduated portion corresponding to the nominal Celsius range.

TABLE 1 Continued

ASTM No.	111C-86	112C-86	113C-86	113F-86 ^{FF}
IP No.				
Name	Tar Acids Distillation	Solidification Point of Benzene	89C Softening Point (Bitumen) Wide Range	
Reference Fig. No.	7	6	4	
Range	170 to 250°C	4 to 6°C	-1 to +175°C	30 to 350°F
For test at		5.4°C		
A Immersion, mm	100	total	total	
Graduations:				
Subdivisions	0.2°C	0.02°C	0.5°C	1°F
Long lines at each	1°C	0.1°C	1°C	5°F
Numbers at each	2°C	0.2°C	5°C	10°F
Scale error, max	0.4°C to 225°C	0.04°C	0.5°C	1°F
	0.6°C above 225°C			
Special inscription	ASTM 111C-86	ASTM 112C-86	ASTM 113C-86 or 113F-86	
Expansion chamber:				
Permit heating to	275°C	50°C	225°C	440°F
B Total length, mm	390 to 400	210 to 220		400 to 410
C Stem OD, mm	6.0 to 7.0	6.0 to 7.5		6.0 to 8.0
D Bulb length, mm	10 to 15	25 to 35		10 to 15
E Bulb OD, mm	6.0 to 7.0	6.0 to ∇ stem		4.5 to 5.5
Scale location:				
Bottom of bulb to line at	170°C	4°C	0°C	32°F
F Distance, mm	115 to 135	100 to 115		80 to 90
G Length of graduated portion, mm	200 to 245 ^O	45 to 75 ^O		250 to 290 ^O
Ice-point scale:				
Range		-0.2 to +0.2°C ^O		
H Bottom of bulb to ice-point, mm		60 to 70		
Contraction chamber:				
I Distance to bottom, min, mm		80		
J Distance to top, max, mm		90 ^I		
K Stem enlargement:	35			
L OD, mm				
M Length, mm				
N Distance to bottom, mm				

^I Contraction chamber to be long narrow type.

^O Capillary clearances shall conform to Section 8.

^{FF} For Fahrenheit thermometers, dimension G (length of graduated portion) shall be measured as the length of graduated portion corresponding to the nominal Celsius range.

TABLE 1 Continued

	ASTM No.	114C-86	115C-86	116C-86	117C-86
IP No.		14C			
Name		Aviation Fuel Freezing Point ^B	See Table 5	Bomb Calorimeter 9 and 14	Bomb Calorimeter 9 and 14
Reference Fig. No.		4			
Range		-80 to + 20°C		18.9 to 25.1°C	23.9 to 30.1°C
For test at					
A Immersion, mm		total		total	total
Graduations:					
Subdivisions		0.5°C		0.01°C	0.01°C
Long lines at each		1°C		0.05°C	0.05°C
Numbers at each		5°C		0.1°C	0.1°C
Scale error, max		1°C		0.1°C ^{JJ}	0.1°C ^{JJ}
Special inscription		ASTM 114C-86		ASTM 116C-86	ASTM 117C-86
Expansion chamber:					
Permit heating to		45°C		60°C	60°C
B Total length, mm		295 to 305		604 to 614	604 to 614
C Stem OD, mm		6.0 to 8.0		7.0 to 8.2	7.0 to 8.2
D Bulb length, mm		8 to 16		^{KK}	^{KK}
E Bulb OD, mm		↗stem		7.0 to 8.2 ^{BB}	7.0 to 8.2 ^{BB}
Scale location:					
Bottom of bulb to line at		-80°C		19°C	24°C
F Distance, mm		50 to 70		220 to 240	220 to 240
G Length of graduated portion, mm		170 to 210 ^O		300 to 350 ^O	300 to 350 ^O
Ice-point scale:					
Range					
H Bottom of bulb to ice-point, mm					
Contraction chamber:					
I Distance to bottom, min, mm					
J Distance to top, max, mm					
Stem enlargement:					
K OD, mm				110	110
L Length, mm					
M Distance to bottom, mm					

^B Toluene or other suitable liquid colored red with a permanent dye shall be used as the actuating liquid.

^O Capillary clearances shall conform to Section 8.

^{BB} The bulb diameter shall not be more than 0.5 mm greater than the stem.

^{JJ} Over any interval of 1°C the change in correction shall not exceed 0.01°C. The correction at the lowest temperature of the nominal range shall not change by more than 0.02°C immediately after the thermometer has been heated for 15 min at a temperature 30°C higher, and allowed to cool naturally in air.

^{KK} The capillary bore shall be large enough in relation to the bulb to ensure that (without tapping) jumping of the meniscus does not exceed one half of the smallest scale division, when the temperature is rising at a uniform rate not exceeding 0.05°C/min.

TABLE 1 Continued

	ASTM No.	118C-86	118F-86 ^{FF}	119C-86	119F-86 ^{FF}	120C-86
IP No. Name						
Reference Fig. No. Range						
For test at						
A		28.6 to 31.4°C 30°C	83.5 to 88.5°F 86°F	-38.3 to -30°C	-37 to -22°F	38.6 to 41.4°C 40°C
Immersion, mm						total
Graduations:						
Subdivisions		0.05°C	0.1°F	0.1°C	0.2°F	0.05°C
Long lines at each		0.1 and 0.5°C	0.5 and 1°F	0.5°C	1°F	0.1 and 0.5°C
Numbers at each		1°C	1°F	1°C	2°F	1°C
Scale error, max		0.1°C	0.2°F	0.2°C	0.4°F	0.1°C
Special inscription						
		ASTM 118C-86 or 118F-86		ASTM 119C-86 or 119F-86 100 MM IMM		ASTM 120C-86
Expansion chamber:						
Permit heating to						
B		105°C	220°F	50°C	122°F	105°C
Total length, mm						300 to 310
C						6.0 to 8.0
Stem OD, mm						45 to 55
D						↗stem
Bulb length, mm						
E						
Bulb OD, mm						
Scale location:						
Bottom of bulb to line at		28.6°C	83.5°F	-38.3°C	-37°F	38.6°C
F						145 to 165
Distance, mm						40 to 90 ^o
G						
Length of graduated portion, mm						
Ice-point scale:						
Range		-0.3 to +0.3°C ^o	31.5 to 32.5°F ^o	-0.5 to +0.5°C ^o	31 to 33°F ^o	-0.3 to +0.3°C ^o
Bottom of bulb to ice-point, mm						
H						
Bottom of bulb to ice-point, mm						
Contraction chamber:						
I						
Distance to bottom, min, mm						100
J						125
Distance to top, max, mm						
Stem enlargement:						
K						
OD, mm						
L						
Length, mm						
M						
Distance to bottom, mm						

^M For kinematic viscosity thermometers, the ice-point reading shall be taken within 1 h after being at the test temperature for not less than 3 minutes. The ice-point reading shall be expressed to the nearest 0.01°C or 0.02°F and applied as explained in Test Method E 77, Section 13.

^O Capillary clearances shall conform to Section 8.

^{FF} For Fahrenheit thermometers, dimension G (length of graduated portion) shall be measured as the length of graduated portion corresponding to the nominal Celsius range.

^{II} The thermometer is to be calibrated for 100-mm immersion for the main scale, the ice point is to be calibrated for total immersion.

TABLE 1 Continued

	121C-86	122C-86	123C-86
IP No.	32C	94C	95C
Name	Kinematic Viscosity ^M	Brookfield Viscosity ^R	Brookfield Viscosity
Ref. Fig. No.	6	4	4
Range	98.6 to 101.4°C	-45 to -35°C	-35 to -25°C
For Test at	98.9 and 100°C		150°C
A Immersion, mm	total	total	total
Graduations:			
Subdivisions	0.05°C	0.1°C	0.1°C
Long Lines at each	0.1 and 0.5°C	0.5°C	0.5°C
Numbers at each	1°C	1°C	1°C
Scale error, max	0.1°C	0.4°C	0.4°C
Special inscription	ASTM	ASTM	ASTM
	121C-86	122C-86	123C-86
		MERC-THAL	
Expansion chamber:			
Permit heating to			
B Total length, mm	130°C	80°C	80°C
C Stem OD, mm	300 to 310	295 to 305	295 to 305
D Bulb length, mm	6.0 to 8.0	5.5 to 8.0	5.5 to 8.0
E Bulb OD, mm	45 to 55	30 to 40	30 to 40
Scale location:			
Bottom of bulb to line at			
F Distance, mm	98.6°C	-45°C	-35°C
G Length of graduated portion, mm	145 to 165	100 to 120	100 to 120
Ice-point scale:	40 to 90°	115 to 165°	115 to 165°
Range	-0.3 to +0.3°C ^O		
H Bottom of bulb to ice-point, mm			
Contraction chamber:			
I Distance to bottom, min, mm	100		
J Distance to top, max, mm	125		
Stem enlargement:			
K OD, mm			
L Length, mm			
M Distance to bottom, mm			

^M For kinematic viscosity thermometers, the ice-point reading shall be taken within 1 h after being at the test temperature for not less than 3 minutes. The ice-point reading shall be expressed to the nearest 0.01°C or 0.02°F and applied as explained in Test Method E 77, Section 13.

^O Capillary clearances shall conform to Section 8.

^R A suitable mercury-thallium alloy shall be used as the actuating liquid.

TABLE 1 Continued

ASTM No.	124C-86	125C-86	126C-86	126F-86 ^{FF}
IP No.	96C	97C	71C	
Name	Brookfield Viscosity	Brookfield Viscosity	Kinematic Viscosity ^M	
Reference Fig. No.	4	4	10	
Range	-25 to -15°C	-15 to -5°C	-27.4 to -24.6°C -26.1°C	-17.5 to -12.5°F -15°F
For test at				
A Immersion, mm	total	total	total	
Graduations:				
Subdivisions	0.1°C	0.1°C	0.05°C	0.1°F
Long lines at each	0.5°C	0.5°C	0.1 and 0.5°C	0.5 and 1°F
Numbers at each	1°C	1°C	1°C	1°F
Scale error, max	0.2°C	0.2°C	0.1°C	0.2°F
Special inscription	ASTM 124C-86	ASTM 125C-86	ASTM 126C-86 or 126F-86	
Expansion chamber:				
Permit heating to	80°C	80°C	105°C	220°F
B Total length, mm	295 to 305	295 to 305		
C Stem OD, mm	5.5 to 8.0	5.5 to 8.0		
D Bulb length, mm	30 to 40	30 to 40		
E Bulb OD, mm	>stem	>stem		
Scale location:				
Bottom of bulb to line at	-25°C	-15°C	-27.4°C	-17.5°F
F Distance, mm	100 to 120	100 to 120		
G Length of graduated portion, mm	115 to 165 ^O	115 to 165 ^O		
Ice-point scale:				
Range			-0.3 to +0.3°C ^O	31.5 to 32.5°F ^O
H Bottom of bulb to ice-point, mm				
Contraction chamber:				
I Distance to bottom, min, mm				180
J Distance to top, max, mm				205
Stem enlargement:				
K OD, mm				
L Length, mm				
M Distance to bottom, mm				

^M For kinematic viscosity thermometers, the ice-point reading shall be taken within 1 h after being at the test temperature for not less than 3 minutes. The ice-point reading shall be expressed to the nearest 0.01°C or 0.02°F and applied as explained in Test Method E 77, Section 13.

^O Capillary clearances shall conform to Section 8.

^{FF} For Fahrenheit thermometers, dimension G (length of graduated portion) shall be measured as the length of graduated portion corresponding to the nominal Celsius range.

TABLE 1 Continued

ASTM No.	127C-86	128C-86	128F-86 ^{FF}	129C-86	129F-86 ^{FF}
IP No.	99C	33C		36C	
Name	Kinematic Viscosity ^M	Kinematic Viscosity ^M	Kinematic Viscosity ^M	Kinematic Viscosity ^M	Kinematic Viscosity ^M
Ref. Fig. No.	10	4	6	6	6
Range	-21.4 to -18.6°C	29.5 to 34.5°F	197.5 to 202.5°F	91.6 to 94.4°C	197.5 to 202.5°F
For Test at	-20°C	32°F	200°F	93.3°C	200°F
A	total	total	total	total	total
Immersion, mm	0.05°C	0.05°C	0.1°F	0.05°C	0.1°F
Graduations:	0.1 and 0.5°C	0.1 and 0.5°C	0.5 and 1°F	0.1 and 0.5°C	0.5 and 1°F
Subdivisions	1°C	1°C	1°F	1°C	1°F
Long Lines at each	0.1°C	0.1°C	0.2°F	0.1°C	0.2°F
Numbers at each	ASTM	ASTM	ASTM	ASTM	ASTM
Scale error, max	127C-86	128C-86 or 128F-86	129C-86 or 129F-86	129C-86 or 129F-86	129C-86 or 129F-86
Special inscription	105°C	105°C	220°F	120°C	250°F
Expansion chamber:					
Permit heating to	300 to 310	300 to 310	300 to 310	300 to 310	300 to 310
Total length, mm	6.0 to 8.0	6.0 to 8.0	6.0 to 8.0	6.0 to 8.0	6.0 to 8.0
B	45 to 55	45 to 55	45 to 55	45 to 55	45 to 55
C	↳stem	↳stem	↳stem	↳stem	↳stem
Stem OD, mm					
D					
Bulb length, mm					
E					
Bulb OD, mm					
Scale location:					
Bottom of bulb to line at	-21.4°C	-1.4°C	29.5°F	91.6°C	197.5°F
F	80 to 110	145 to 165	145 to 165	145 to 165	145 to 165
Distance, mm	40 to 90 ^o	40 to 90 ^o	40 to 90 ^o	40 to 90 ^o	40 to 90 ^o
G					
Length of graduated portion, mm					
Ice-point scale:					
Range	-0.3 to + 0.3°C ^o	-0.3 to + 0.3°C ^o	-0.3 to + 0.3°C ^o	-0.3 to + 0.3°C ^o	31.5 to 32.5°F ^o
H					
Bottom of bulb to ice-point, mm					
Contraction chamber:					
I	180				100
Distance to bottom, min, mm					125
J	205				
Distance to top, max, mm					
Stem enlargement:					
K					
OD, mm					
L					
Length, mm					
M					
Distance to bottom, mm					

^M For kinematic viscosity thermometers, the ice-point reading shall be taken within 1 h after being at the test temperature for not less than 3 minutes. The ice-point reading shall be expressed to the nearest 0.01°C or 0.02°F and applied as explained in Test Method E 77, Section 13.

^o Capillary clearance shall conform to Section 8.

^{FF} For Fahrenheit thermometers, dimension G (length of graduated portion) shall be measured as the length of graduated portion corresponding to the nominal Celsius range.

TABLE 1 Continued

	436G-90	430F-90 ^{FF}	432G-95	433G-01	434G-02
ASTM-No.	130C-90	130F-90 ^{FF}	132C-95	133C-01	134C-03
IP No.			10ZC		37C
Name			Kinematic Viscosity ^M		Sludge
Ref. Fig. No.			6		3
Range		20 to 220°F	148.6 to 151.4°C		144 to 156°C
For Test at			150°C		150°C
A Immersion, mm	-7 to +105°C		total		100
Graduations:					
Subdivisions	0.5°C	1°F	0.05°C	0.1°C	0.2°C
Long Lines at each	1°C	5°F	0.1 and 0.5°C	0.5°C	1°C
Numbers at each	5°C	10°F	1°C	1°C	2°C
Scale error, max	0.5°C	1°F	0.20°C	0.1°C	0.2°C
Special inscription			ASTM	ASTM	ASTM
		430G-90 or 430F-90	432G-95	433G-01	434G-02
Special inscription				76-MM IMM	100-MM IMM
		130C-90 or 130F-90		ASTM	ASTM
				133C-01	134C-03
				76 MM IMM	100 MM IMM
Expansion chamber:					
Permit heating to					
B Total length, mm	125°C	257°F	185°C	55°C	required
C Stem OD, mm			300 to 310	374 to 384	260 to 280
D Bulb length, mm			6.0 to 8.0	7.0 to 8.0	5.0 to 8.0
E Bulb-OD, mm			45 to 55	25 to 35	10 to 25
E Bulb OD, mm			→stem	→stem	Net greater than stem
E Bulb OD, mm			→stem	→stem	→stem
Scale location:					
Bottom of bulb to line at			148.6°C		150°C
F Distance, mm	0°C	32°F	160 to 180	-38°C	170 to 210
G Length of graduated portion, mm			40 to 90°C ^O	115 to 135	50 to 80 ^O
Ice-point scale:					
Range			-0.3 to +0.6°C ^O		
H Bottom of bulb to ice-point, mm					
Contraction chamber:					
I Distance to bottom, min, mm			100		required
J Distance to top, max, mm			125		
Stem enlargement:					
K OD, mm					
L Length, mm					
M Distance to bottom, mm					

^{AA} Special finish, see 6.2.2.

^{CC} The stem shall be of the lens front type. The cross section of the stem shall be such that it will pass through a 8.0-mm ring gage but will not enter a 5.0-mm slot gage. A minor diameter of 4-mm is permissible provided that the major diameter is not less than 7 mm.

^O Capillary clearances shall conform to Section 8.

^{FF} For Fahrenheit thermometers, dimension G (length of graduated portion) shall be measured as the length of graduated portion corresponding to the nominal Celsius range.

TABLE 1 Continued

	ASTM No.	135C-03	135F-03 ^{FF}	136C-03	136F-03 ^{FF}	137C-03
IP No.						
Name						
Ref. Fig. No.						
Name		Fuel-Rating-Air-High 44		Aviation-Fuel-Density 4		
Ref. Fig. No.		11		4		
Range		38 to 93°C 51.7°C ^G	100 to 200°F 125°F ^G	-20 to +60°C	-5 to +140°F	Oxidation Cell Test 3 80 to 100°C
For Test at						
A Immersion, mm		40 ^{EE} 40 ^{EE}		total total		76
Graduations:						
Subdivisions		1°C	1°F	0.2°C	0.5°F	0.1°C
Long Lines at each		5°C	5°F	1°C	1°F	0.5°C
Numbers at each		10°C	10°F	2°C	5°F	2°C
Scale error, max		1°C	2°F	0.15°C	0.25°F	0.1°C
Special inscription		ASTM 435G-03 or 135F-03 40-MM IMM		ASTM 436G-03 or 136F-03		
Special inscription		ASTM 135C-03 or 135F-03 40 MM IMM		ASTM 136C-03 or 136F-03		ASTM 137C-03 76 MM IMM
Expansion chamber:						
Permit heating to		125°C	250°F	110°C	230°F	130°C
B Total length, mm		468 to 474				250 to 260
G Total length, mm		168 to 174				∞
B Stem-OD, mm		6.0 to 7.0				18 to 28
C Stem OD, mm		6.0 to 7.0				≥6.0 and ≤stem
D Bulb length, mm		6 to 11				
E Bulb length, mm		5.0 to 6.5				
F Bulb OD, mm		5.0 to 6.5				
Scale location:						
Bottom of bulb to line at		38°C	100°F	-20°C	-4°F	80°C
F Distance, mm		74 to 78				90 to 100
F Distance, mm		71 to 78				115 to 125
G Length of graduated portion, mm		64 to 84 ^O				
G Length of graduated portion, mm		64 to 81 ^O				
ice-point scale:						
Range						
H Bottom of bulb to ice-point, mm						
Contraction chamber:						
I Distance to bottom, min, mm						
J Distance to top, max, mm						
Stem enlargement:						
K OD, mm		8.0 to 9.0				45
L Length, mm						
M Distance to bottom, mm		38 to 42				

^{AA} Special finish, see 6.2.2.

^{CC} The stem shall be of the lens front type. The cross section of the stem shall be such that it will pass through a 8.0-mm ring gage but will not enter a 5.0-mm slot gage. A minor diameter of 4-mm is permissible provided that the major diameter is not less than 7 mm.

^O Capillary clearances shall conform to Section 8.

^{FF} For Fahrenheit thermometers, dimension G (length of graduated portion) shall be measured as the length of graduated portion corresponding to the nominal Celsius range.

TABLE 2 Alphabetical List of ASTM Thermometers Covered by Specification E 1

NOTE 1—The specifications appear in numeric sequence in this standard.

Thermometer Name	Thermometer No.		Thermometer Name	Thermometer No.	
	°C	°F		°C	°F
Aviation fuel density	136C	136F	
Aviation fuel freezing point	114C	...		3C	3F
Bomb calorimeter	56C	56F	Petrolatum melting point	61C	61F
	116C	...	Precision	62C	62F
	117C	...		63C	63F
Brookfield Viscosity	122C	...		64C	64F
	123C	...		65C	65F
	124C	...		66C	66F
	125C	...		67C	67F
Butadiene boiling point range	52C	...		68C	68F
Cleveland open flash	11C	11F		69C	69F
Cloud and pour	5C	5F		70C	70F
		133C	...
Cloud and pour	5C	5F		70C	70F
		133C	...
Cloud and pour, low	6C	6F	Reid vapor pressure	18C	18F
Congealing point	54C	54F	Saybolt viscosity	17C	17F
Coolant (antifreeze) freezing point	...	75F		18C	18F
	...	76F		19C	19F
	119C	119F		20C	20F
Density wide range	12C	12F		21C	21F
Enclosed scale	115C	...		22C	22F
Engler viscosity	23C	77F
	24C	78F
	25C	79F
Fuel rating	82C	82F		...	80F
	83C	83F		...	81F
	84C	84F		...	108F
	85C	85F		...	109F
	Sludge	134C	...
	86C	86F	Softening point (bitumen) wide-range	113C	113F
	87C	87F	Solidification point	89C	...
	135C	135F	
Gas calorimeter, inlet	...	50F		90C	...
Gas calorimeter, outlet	...	51F		91C	...
General purpose—see partial immersion; precision				92C	...
Gravity	12C	12F		93C	...
High aniline point	35C	35F		94C	...
High distillation	8C	8F		95C	...
High Pensky Martens	10C	10F		96C	...
High softening point	16C	16F		100C	...
Kinematic viscosity	28C	28F		101C	...
	29C	29F	Solidification point of benzene	112C	...
	...	30F	Solvents distillation	37C	...
	43C	43F		38C	...
	44C	44F		39C	...
	45C	45F		40C	...
	46C	46F		41C	...
	47C	47F		42C	...
	48C	48F		102C	...
	72C	72F		103C	...
	73C	73F		104C	...
	74C	74F		105C	...
	110C	110F		106C	...
	118C	118F		107C	...
	120C	...	Stability test of soluble nitrocellulose	26C	...
	121C	...	Stormer viscosity	49C	...
	126C	126F	Tag closed tester, low range	57C	57F
	127C	...	Tag closed tester, high range	9C	9F
	128C	128F	Tank	58C	58F
	129C	129F		59C	59F
	132C	...			
Loss on heat	13C	...		60C	60F
Low aniline point	33C	33F		97C	97F
Low cloud and pour	6C	6F		98C	98F
Low distillation	7C	7F		130C	130F
Low Pensky Martens	9C	9F	Tar acids distillation	111C	...
Low softening point	15C	15F	Titer test	36C	...
Medium aniline point	34C	34F	Turpentine distillation	27C	...

Thermometer Name	Thermometer No.		Thermometer Name	Thermometer No.	
	°C	°F		°C	°F
Oil in wax	71C	71F	Vegetable oil flash	88C	88F
Oxidation cell test	137C
Oxidation stability	22C	22F	Wax melting point	14C	14F
Partial immersion (general use)	1C	1F	Weathering test	99C	99F
	2C	2F			

TABLE 3 List of ASTM Thermometers by Temperature Range

Celsius (Centigrade) Range	Immersion, mm	Scale Error, max	ASTM Thermometer Number	Fahrenheit Range	Immersion, mm	Scale Error, max	ASTM Thermometer Number
Graduated in 0.01°C				Graduated in 0.05°F			
18.9 to 25.1°C	total	0.1	116C
23.9 to 30.1°C	total	0.1	117C
Graduated in 0.02°C				Graduated in 0.1°F			
4 to 6°C	total	0.04	112C
19 to 35°C	total	0.10	56C	66 to 95°F	total	0.20	56F
Graduated in 0.05°C				Graduated in 0.1°F			
-55.4 to -52.6°C	total	0.1	74C	-67.5 to -62.5°F	total	0.2	74F
-41.4 to -38.6°C	total	0.1	73C	-42.5 to -37.5°F	total	0.2	73F
-27.4 to -24.6°C	total	0.1	126C	-17.5 to -12.5°F	total	0.2	126F
-21.4 to -18.6°C	total	0.1	127C
-19.4 to -16.6°C	total	0.1	72C	-2.5 to +2.5°F	total	0.2	72F
-1.4 to +1.4°C	total	0.1	128C	29.5 to 34.5°F	total	0.2	128F
...	54 to 101°F	total	0.2	50F
18.6 to 21.4°C	total	0.1	44C	66.5 to 71.5°F	total	0.2	44F
...	69 to 116°F	total	0.2	51F
23.6 to 26.4°C	total	0.1	45C	74.5 to 79.5°F	total	0.2	45F
28.6 to 31.4°C	total	0.1	118C	83.5 to 88.5°F	total	0.2	118F
36.6 to 39.4°C	total	0.1	28C	97.5 to 102.5°F	total	0.2	28F
38.5 to 41.5°C	total	0.1	120C
48.6 to 51.4°C	total	0.1	46C	119.5 to 124.5°F	total	0.2	46F
52.6 to 55.4°C	total	0.1	29C	127.5 to 132.5°F	total	0.2	29F
58.6 to 61.4°C	total	0.1	47C	137.5 to 142.5°F	total	0.2	47F
80.6 to 83.4°C	total	0.1	48C	177.5 to 182.5°F	total	0.2	48F
91.6 to 94.4°C	total	0.1	129C	197.5 to 202.5°F	total	0.2	129F
...	207.5 to 212.5°F	total	0.2	30F
98.6 to 101.4°C	total	0.1	121C
133.6 to 136.4°C	total	0.15	110C	272.5 to 277.5°F	total	0.3	110F
148.6 to 151.4°C	total	0.20	132C				
Graduated in 0.1°C				Graduated in 0.2°F			
-51.6 to -34°C	total	0.1	43C	-61 to -29°F	total	0.2	43F
-45 to -35°C	total	0.4	122C
-38.3 to -30°C	100	0.2	119C	-37 to -22°F	100	0.4	119F
-38 to +2°C	total	0.1	62C	-36 to +35°F	total	0.2	62F
-38 to +2°C	76 mm	0.1	133C
-35 to -25°C	total	0.4	123C
-25 to -15°C	total	0.2	124C
-15 to -5°C	total	0.2	125C
-20 to +10°C	76	0.1	89C
-10 to +5°C	total	0.1	52C
-8 to +32°C	total	0.1	63C	18 to 89°F	total	0.2	63F
0 to 30°C	76	0.1	90C
19 to 27°C	total	0.1	17C	66 to 80°F	total	0.2	17F
20 to 50°C	76	0.1	91C
25 to 55°C	total	0.1	64C	77 to 131°F	total	0.2	64F
34 to 42°C	total	0.1	18C	94 to 108°F	total	0.2	18F
38 to 82°C	79	0.1	14C	100 to 180°F	79	0.2	14F
40 to 70°C	76	0.1	92C
49 to 57°C	total	0.1	19C	120 to 134°F	total	0.2	19F
50 to 80°C	total	0.1	65C	122 to 176°F	total	0.2	65F
57 to 65°C	total	0.1	20C	134 to 148°F	total	0.2	20F
60 to 90°C	76	0.1	93C
75 to 105°C	total	0.1	66C	167 to 221°F	total	0.2	66F
79 to 87°C	total	0.1	21C	174 to 188°F	total	0.2	21F
80 to 100°C	76	0.1	137C
80 to 110°C	76	0.1	94C
95 to 103°C	total	0.1	22C	204 to 218°F	total	0.2	22F
100 to 130°C	76	0.2	95C

TABLE 3 Continued

Celsius (Centigrade) Range	Immersion, mm	Scale Error, max	ASTM Thermometer Number	Fahrenheit Range	Immersion, mm	Scale Error, max	ASTM Thermometer Number
120 to 150°C	76	0.2	96C
130 to 140°C	total	0.2	26C
Graduated in 0.2°C				Graduated in 0.5°F			
...	-65 to +5°F	100	1	76F
-50 to +5°C	35	0.2	99C	-55 to +40°F	35	0.4	99F
-38 to +42°C	50	0.2	33C	-36.5 to +107.5°F	50	0.5	33F
...	-35 to +35°F	100	0.5	75F
-20 to +60°C	total	0.15	136C	-5 to +140°F	total	0.25	136F
-20 to +102°C	total	0.4	12C	-5 to +215°F	total	0.25	12F
-20 to +102°C	total	0.15	12C	-5 to +215°F	total	0.25	12F
-2 to +52°C	100	0.2	37C
-2 to +68°C	45	0.2	36C
-2 to +80°C	total	0.2	15C	30 to 180°F	total	0.4	15F
18 to 28°C	90	0.1	23C
20 to 70°C	65	0.2	49C
20 to 100.6°C	total	0.2	54C	68 to 213°F	total	0.5	54F
24 to 78°C	100	0.2	38C
25 to 105°C	50	0.2	34C	77 to 221°F	50	0.5	34F
32 to 127°C	79	0.2	61C	90 to 260°F	79	0.5	61F
39 to 54°C	90	0.1	24C
48 to 102°C	100	0.2	39C
72 to 126°C	100	0.2	40C
90 to 170°C	50	0.4	35C	194 to 338°F	50	1	35F
95 to 105°C	90	0.1	25C
98 to 152°C	100	0.3	41C
95 to 155°C	total	0.2	67C	203 to 311°F	total	0.5	67F
...	245 to 265°F	total	0.5	77F
123 to 177°C	100	0.3	102C
...	270 to 290°F	total	0.5	108F
...	295 to 315°F	total	0.5	78F
144 to 156°C	100	0.2	134C	295 to 315°F	total	0.5	78F
145 to 205°C	total	0.2	68C	293 to 401°F	total	0.5	68F
145 to 205°C	76	0.4	100C
148 to 202°C	100	0.4	103C
...	320 to 340°F	total	0.5	109F
170 to 250°C	100	^A	111C
173 to 227°C	100	0.4	104C
...	345 to 365°F	total	0.5	79F
198 to 252°C	100	0.6	105C
...	395 to 415°F	total	0.5	80F
...	445 to 465°F	total	0.5	81F
223 to 277°C	100	0.8	106C
248 to 302°C	100	1	107C
Graduated in 0.5°C				Graduated in 1°F			
-80 to +20°C	total	1	114C
-37 to +21°C	76	0.2	71C	-35 to +70°F	76	0.5	71F
-34 to +49°C	total	0.5	58C	-30 to +120°F	total	0.5	58F
-20 to +50°C	57	0.5	57C	-4 to +122°F	57	1	57F
-18 to +49°C	total	0.5	97C	0 to 120°F	total	0.5	97F
-18 to +82°C	total	0.5	59C	0 to 180°F	total	0.5	59F
-7 to +105°C	total	0.5	130C	20 to 220°F	total	1	130F
-5 to +110°C	57	0.5	9C	20 to 230°F	57	1	9F
-1 to +175°C	total	0.5	113C	30 to 350°F	total	1	113F
...	60 to 160°F	40	2	83F
16 to 82°C	total	0.5	98C	60 to 180°F	total	0.5	98F
...	75 to 175°F	249	2	84F
30 to 200°C	total	0.3	16C	85 to 392°F	total	0.5	16F
95 to 255°C	400	4	42C
95 to 255°C	100	1	42C	100 to 200°F	40	2	135F
147 to 182°C	76	0.5	27C
155 to 170°C	total	0.5	13C
...	300 to 400°F	40	2	87F
195 to 305°C	total	0.5	69C	383 to 581°F	total	1	69F
195 to 305°C	76	1	101C
295 to 405°C	total	0.5	70C	563 to 761°F	total	1	70F
Graduated in 1°C				Graduated in 2°F			
-80 to +20°C	76	^B	6C	-112 to +70°F	76	^C	6F
-38 to +50°C	108	0.5	5C	-36 to +120°F	108	1	5F
-15 to +105°C	30	1	82C	0 to 220°F	30	2	82F

TABLE 3 *Continued*

Celsius (Centigrade) Range	Immersion, mm	Scale Error, max	ASTM Thermometer Number	Fahrenheit Range	Immersion, mm	Scale Error, max	ASTM Thermometer Number
-20 to +150°C	76	0.5	1C	0 to 302°F	76	1	1F
-5 to +300°C	76	1	2C	20 to 580°F	76	2	2F
-5 to +400°C	76	^D	3C	20 to 760°F	76	^E	3F
-2 to +300°C	total	^F	7C	30 to 580°F	total	^G	7F
-2 to +400°C	total	^H	8C	30 to 760°F	total	^I	8F
10 to 200°C	57	1	88C	50 to 392°F	57	2	88F
15 to 70°C	40	1	83C
25 to 80°C	249	1	84C
38 to 93°C	40	1	135C
40 to 150°C	181	1	85C	100 to 300°F	181	^J	85F
77 to 260°C	total	1	60C	170 to 500°F	total	1	60F
95 to 175°C	35	1	86C	200 to 350°F	35	2	86F
150 to 205°C	40	1	87C
Graduated in 2°C				Graduated in 5°F			
-6 to +400°C	25	^K	11C	20 to 760°F	25	^L	11F
90 to 370°C	57	^M	10C	200 to 700°F	57	^N	10F

^A 0.4°C to 225°C; 0.6°C above 225°C.
^B 1°C to -33°C; 2°C below -33°C.
^C 2°F to -28°F; 4°F below -28°F.
^D 1°C to 301°C; 1.5°C above 301°C.
^E 2°F to 574°F; 3°F above 574°F.
^F 0.5°C to 150°C; 1°C above 150°C.
^G 1°F to 300°F; 2°F above 300°F.
^H 1°C to 300°C; 1.5°C above 300°C.
^I 2°F to 570°F; 3°F above 570°F.
^J 2°C to 260°C; 4°C above 260°C.
^K 5°F to 500°F; 7°F above 500°F.
^L 1°C to 260°C; 2°C above 260°C.
^M 2.5°F to 500°F; 3.5°F above 500°F.

TABLE 4 Verification and Calibration Temperatures^A

Temperature	Av Temp. of Emergent Mercury Column	Temperature	Av Temp. of Emergent Mercury Column	Temperature	Av Temp. of Emergent Mercury Column	Temperature	Av Temp. of Emergent Mercury Column
Thermometer 1C -20 to +150°C		Thermometer 1F 0 to 302°F		Thermometer 2C -5 to +300°C		Thermometer 2F -20 to +580°F	
-20°C	15°C	0°F	60°F	0°C	22°C	32°F	72°F
0°C	22°C	32°F	72°F	75°C	34°C	150°F	90°F
50°C	30°C	122°F	86°F	150°C	35°C	300°F	95°F
100°C	33°C	212°F	91°F	225°C	40°C	450°F	105°F
150°C	36°C	302°F	97°F	300°C	45°C	580°F	114°F
Thermometer 3C -5 to +400°C		Thermometer 3F 20 to 760°F		Thermometer 5C -38 to +50°C		Thermometer 5F -36 to +120°F	
0°C	21°C	32°F	70°F	-35°C	21°C	-30°F	70°F
100°C	33°C	200°F	90°F	0°C	21°C	32°F	70°F
200°C	39°C	370°F	101°F	50°C	21°C	120°F	70°F
300°C	44°C	540°F	110°F				
370°C	54°C	700°F	129°F				
Thermometer 6C -80 to +20°C		Thermometer 6F -112 to +70°F		Thermometer 7C -2 to +300°C		Thermometer 7F 30 to 580°F	
-70°C	21°C	-94°F	70°F	0°C		32°F	
-35°C	21°C	-30°F	70°F	50°C		100°F	
0°C ^B	21°C	32°F ^B	70°F	100°C		200°F	
20°C	21°C	70°F	70°F	150°C		300°F	
				200°C		400°F	
				250°C		500°F	
				300°C		570°F	
Thermometer 8C -2 to +400°C		Thermometer 8F 30 to 760°F		Thermometer 9C -5 to +110°C		Thermometer 9F 20 to 230°F	
0°C		32°F		0°C	19°C	32°F	66°F
100°C		200°F		35°C	28°C	100°F	86°F
200°C		370°F		70°C	40°C	160°F	106°F
300°C		540°F		105°C	50°C	220°F	123°F
370°C		700°F					

TABLE 4 *Continued*

Temperature	Av Temp. of Emergent Mercury Column	Temperature	Av Temp. of Emergent Mercury Column	Temperature	Av Temp. of Emergent Mercury Column	Temperature	Av Temp. of Emergent Mercury Column
Thermometer 10C 90 to 370°C		Thermometer 10F 200 to 700°F		Thermometer 11C –6 to +400°C		Thermometer 11F 20 to 760°F	
100°C	61°C	212°F	141°F	0°C	18°C	32°F	64°F
200°C	71°C	390°F	159°F	100°C	44°C	200°F	110°F
300°C	87°C	570°F	189°F	200°C	64°C	370°F	144°F
370°C	104°C	700°F	220°F	300°C	91°C	540°F	187°F
				370°C	115°C	700°F	240°F
Thermometer 12C –20 to +102°C		Thermometer 12F –5 to +215°F		Thermometer 13C 155 to 170°C		Thermometer 14C 38 to 82°C	
–20°C		–5°F		155°C		40°C	25°C
–10°C		15°F		163°C		50°C	25°C
0°C		32°F		170°C		60°C	25°C
10°C		60°F				70°C	25°C
20°C		85°F				80°C	25°C
30°C		110°F					
40°C		135°F					
50°C		160°F					
60°C		185°F					
70°C		210°F					
80°C							
90°C							
100°C							
Thermometer 14F 100 to 180°F		Thermometer 15C –2 to +80°C		Thermometer 15F 30 to 180°F		Thermometer 16C 30 to 200°C	
100°F	77°F	0°C		32°F		30°C	
120°F	77°F	20°C		70°F		60°C	
140°F	77°F	40°C		100°F		90°C	
160°F	77°F	60°C		140°F		120°C	
180°F	77°F	80°C		180°F		150°C	
						180°C	
						200°C	
Thermometer 16F 85 to 392°F		Thermometer 17C 19 to 27°C		Thermometer 17F 66 to 80°F		Thermometer 18C 34 to 42°C	
90°F		21°C		70°F		38°C	
140°F		25°C		77°F		41°C	
190°F							
240°F							
290°F							
340°F							
390°F							
Thermometer 18F 94 to 108°F		Thermometer 19C 49 to 57°C		Thermometer 19F 120 to 134°F		Thermometer 20C 57 to 65°C	
100°F		50°C		122°F		60°C	
107°F		54°C		130°F		64°C	
Thermometer 20F 134 to 148°F		Thermometer 21C 79 to 87°C		Thermometer 21F 174 to 188°F		Thermometer 22C 95 to 103°C	
140°F		82°C		180°F		99°C	
147°F		86°C		187°F		102°C	
Thermometer 22F 204 to 218°F		Thermometer 23C 18 to 28°C		Thermometer 24C 39 to 54°C		Thermometer 25C 95 to 105°C	
210°F		20°C	22°C	40°C	35°C	95°C	75°C
212°F		25°C	25°C	50°C	42°C	100°C	64°C
Thermometer 26C 130 to 140°C		Thermometer 27C 147 to 182°C		Thermometer 28C 36.6 to 39.4°C		Thermometer 28F 97.5 to 102.5°F	
130°C		155°C	25°C	0°C		32°F	
135°C		165°C	25°C	37.8°C		100°F	
140°C		175°C	25°C	39°C		102°F	
Thermometer 29C 52.6 to 55.4°C		Thermometer 29F 127.5 to 132.5°F		Thermometer 30F 207.5 to 212.5°F		Thermometer 33C –38 to +42°C	

TABLE 4 *Continued*

Temperature	Av Temp. of Emergent Mercury Column	Temperature	Av Temp. of Emergent Mercury Column	Temperature	Av Temp. of Emergent Mercury Column	Temperature	Av Temp. of Emergent Mercury Column
0°C		32°F		32°F		-35°C	5°C
54.4°C		130°F		210°F		-20°C	15°C
55°C		132°F		212°F		0°C	20°C
						20°C	25°C
						40°C	30°C
Thermometer 33F -36.5 to +107.5°F		Thermometer 34C 25 to 105°C		Thermometer 34F 77 to 221°F		Thermometer 35C 90 to 170°C	
-31°F	41°F	25°C	25°C	77°F	77°F	100°C	70°C
-4°F	59°F	45°C	37°C	113°F	99°F	120°C	63°C
32°F	68°F	65°C	43°C	149°F	109°F	140°C	57°C
68°F	77°F	85°C	45°C	185°F	113°F	160°C	50°C
104°F	86°F	100°C	45°C	212°F	113°F	170°C	47°C
Thermometer 35F 194 to 338°F		Thermometer 36C -2 to +68°C		Thermometer 37C -2 to +52°C		Thermometer 38C 24 to 78°C	
212°F	158°F	0°C	25°C	0°C	25°C	25°C	25°C
250°F	145°F	15°C	25°C	15°C	25°C	40°C	25°C
285°F	134°F	30°C	25°C	30°C	25°C	55°C	25°C
320°F	122°F	45°C	25°C	50°C	25°C	75°C	25°C
338°F	116°F	65°C	25°C				
Thermometer 39C 48 to 102°C		Thermometer 40C 72 to 126°C		Thermometer 41C 98 to 152°C		Thermometer 42C 95 to 255°C	
50°C	30°C	75°C	30°C	100°C	30°C	100°C	30°C
65°C	30°C	90°C	30°C	115°C	33°C	150°C	35°C
80°C	30°C	105°C	30°C	130°C	35°C	200°C	40°C
100°C	30°C	125°C	30°C	150°C	35°C	250°C	45°C
Thermometer 43C -51.6 to -34°C		Thermometer 43F -61 to -29°F		Thermometer 44C 18.6 to 21.4°C		Thermometer 44F 66.5 to 71.5°F	
-50°C		-60°F		0°C		32°F	
-45°C		-50°F		20°C		68°F	
-40°C		-40°F		21°C		70°F	
-35°C		-30°F					
0°C		+ 32°F					
Thermometer 45C 23.6 to 26.4°C		Thermometer 45F 74.5 to 79.5°F		Thermometer 46C 48.6 to 51.4°C		Thermometer 46F 119.5 to 124.5	
0°C		32°F		0°C		32°F	
25°C		77°F		50°C		122°F	
26°C		79°F		51°C		124°F	
Thermometer 47C 58.6 to 61.4°C		Thermometer 47F 137.5 to 142.5°F		Thermometer 48C 80.6 to 83.4°C		Thermometer 48F 177.5 to 182.5°F	
0°C		32°F		0°C		32°F	
60°C		140°F		82.2°C		180°F	
61°C		142°F		83°C		182°F	
Thermometer 49C 20 to 70°C		Thermometer 50F 54 to 101°F		Thermometer 51F 69 to 116°F		Thermometer 52C -10 to +5°C	
20°C	25°C					-10°C	
35°C	25°C		every 5° from 55°F		every 5° from 70°F	0°C	
50°C	25°C					5°C	
70°C	25°C						
Thermometer 54C 20 to 100°C		Thermometer 54F 68 to 213°F		Thermometer 56C 19 to 35°C		Thermometer 56F 66 to 95°F	
20°C		70°F					
50°C		120°F			every 2° from 19°C		every 4° from 66°F and including 95°F
75°C		170°F					
100°C		210°F					
Thermometer 57C -20 to +50°C		Thermometer 57F -4 to +122°F		Thermometer 58C -34 to +49°C		Thermometer 58F -30 to +120°F	
-20°C	25°C	-3°F	77°F	-30°C		-20°F	
0°C	25°C	32°F	77°F	0°C		32°F	
25°C	25°C	77°F	77°F	25°C		80°F	
50°C	25°C	122°F	77°F	45°C		120°F	
Thermometer 59C -18 to +82°C		Thermometer 59F 0 to 180°F		Thermometer 60C 77 to 260°C		Thermometer 60F 170 to 500°F	

TABLE 4 *Continued*

Temperature	Av Temp. of Emergent Mercury Column	Temperature	Av Temp. of Emergent Mercury Column	Temperature	Av Temp. of Emergent Mercury Column	Temperature	Av Temp. of Emergent Mercury Column
0°C		32°F		100°C		212°F	
25°C		80°F		175°C		350°F	
55°C		130°F		255°C		490°F	
80°C		180°F					
Thermometer 61C 32 to 127°C		Thermometer 61F 90 to 260°F		Thermometer 62C –38 to +2°C		Thermometer 62F –36 to +35°F	
40°C	25°C	100°F	77°F	–37°C		–35°F	
60°C	25°C	150°F	77°F	–30°C		–15°F	
80°C	25°C	200°F	77°F	–20°C		0°F	
100°C	25°C	250°F	77°F	–10°C		15°F	
120°C	25°C			0°C		32°F	
Thermometer 63C –8 to +32°C		Thermometer 63F 18 to 89°F		Thermometer 64C 25 to 55°C		Thermometer 64F 77 to 131°F	
–7°C		20°F		0°C		32°F	
0°C		32°F		25°C		80°F	
10°C		50°F		35°C		95°F	
20°C		70°F		45°C		115°F	
30°C		88°F		55°C		130°F	
Thermometer 65C 50 to 80°C		Thermometer 65F 122 to 176°F		Thermometer 66C 75 to 105°C		Thermometer 66F 167 to 221°F	
0°C		32°F		0°C		32°F	
50°C		125°F		75°C		168°F	
60°C		145°F		85°C		185°F	
70°C		160°F		95°C		200°F	
80°C		175°F		105°C		220°F	
Thermometer 67C 95 to 155°C		Thermometer 67F 203 to 311°F		Thermometer 68C 145 to 205°C		Thermometer 68F 293 to 401°F	
0°C		32°F		0°C		32°F	
100°C		205°F		150°C		300°F	
110°C		240°F		170°C		340°F	
130°C		275°F		190°C		370°F	
150°C		310°F		205°C		400°F	
Thermometer 69C 195 to 305°C		Thermometer 69F 383 to 581°F		Thermometer 70C 295 to 405°C		Thermometer 70F 563 to 761°F	
0°C		32°F		0°C		32°F	
200°C		400°F		300°C		570°F	
235°C		460°F		335°C		640°F	
270°C		520°F		370°C		700°F	
305°C		580°F		400°C		760°F	
Thermometer 71C –37 to +21°C		Thermometer 71F –35 to +70°F		Thermometer 72C –19.4 to –16.6°C		Thermometer 72F –2.5 to +2.5°F	
–35°C	21°C	–30°F	70°F	–19°C		–2°F	
–18°C	21°C	0°F	70°F	–17.8°C		0°F	
0°C	21°C	32°F	70°F	0°C		32°F	
20°C	21°C	70°F	70°F				
Thermometer 73C –41.4 to –38.6°C		Thermometer 73F –42.5 to –37.5°F		Thermometer 74C –55.4 to –52.6°C		Thermometer 74F –67.5 to –62.5°F	
–41°C		–42°F		–55°C		–67°F	
–40°C		–40°F		–53.9°C		–65°F	
0°C		32°F		0°C		32°F	
Thermometer 75F –35 to +35°F		Thermometer 76F –65 to +5°F		Thermometer 77F 245 to 265°F		Thermometer 78F 295 to 315°F	
–35°F	55°F	–65°F	25°F	250°F		300°F	
0°F	65°F	–30°F	55°F	260°F		310°F	
32°F	75°F	+ 5°F	75°F				
Thermometer 79F 345 to 365°F		Thermometer 80F 395 to 415°F		Thermometer 81F 445 to 465°F		Thermometer 82C –15 to +105°C	
350°F		400°F		450°F		0°C	71°C
360°F		410°F		460°F		50°C	71°C
						100°C	71°C
Thermometer 82F 0 to 220°F		Thermometer 83C 15 to 70°C		Thermometer 83F 60 to 160°F		Thermometer 84C 25 to 80°C	

TABLE 4 *Continued*

Temperature	Av Temp. of Emergent Mercury Column	Temperature	Av Temp. of Emergent Mercury Column	Temperature	Av Temp. of Emergent Mercury Column	Temperature	Av Temp. of Emergent Mercury Column
32°F	160°F	25°C	35°C	85°F	95°F	30°C	27°C
100°F	160°F	70°C	35°C	135°F	95°F	80°C	27°C
200°F	160°F						
Thermometer 84F 75 to 175°F		Thermometer 85C 40 to 150°C		Thermometer 85F 100 to 300°F		Thermometer 86C 95 to 175°C	
100°F	80°F	50°C	54°C	150°F	130°F	100°C	99°C
150°F	80°F	150°C	54°C	250°F	130°F	175°C	99°C
Thermometer 86F 200 to 350°F		Thermometer 87C 150 to 205°C		Thermometer 87F 300 to 400°F		Thermometer 88C 10 to 200°C	
225°F	210°F	160°C	132°C	300°F	270°F	40°C	48°C
325°F	210°F	200°C	132°C	400°F	270°F	100°C	56°C
						150°C	62°C
						200°C	68°C
Thermometer 88F 50 to 392°F		Thermometer 89C -20 to +10°C		Thermometer 90C 0 to 30°C		Thermometer 91C 20 to 50°C	
110°F	119°F	-20°C	15°C	0°C	20°C	20°C	25°C
212°F	132°F	-10°C	15°C	10°C	20°C	30°C	25°C
300°F	143°F	0°C	15°C	20°C	20°C	40°C	25°C
392°F	154°F	10°C	15°C	30°C	20°C	50°C	25°C
Thermometer 92C 40 to 70°C		Thermometer 93C 60 to 90°C		Thermometer 94C 80 to 110°C		Thermometer 95C 100 to 130°C	
40°C	25°C	60°C	30°C	80°C	30°C	100°C	35°C
50°C	25°C	70°C	30°C	90°C	30°C	110°C	35°C
60°C	25°C	80°C	30°C	100°C	30°C	120°C	35°C
70°C	25°C	90°C	30°C	110°C	30°C	130°C	35°C
Thermometer 96C 120 to 150°C		Thermometer 97C -18 to +49°C		Thermometer 97F 0 to 120°F		Thermometer 98C 16 to 82°C	
120°C	35°C	-15°C		0°F		20°C	
130°C	35°C	0°C		32°F		40°C	
140°C	35°C	20°C		70°F		60°C	
150°C	35°C	45°C		110°F		80°C	
Thermometer 98F 60 to 180°F		Thermometer 99C -50 to +5°C		Thermometer 99F -58 to +41°F		Thermometer 100C 145 to 205°C	
60°F		-46°C	-23°C	-50°F	-10°F	145°C	40°C
100°F		-32°C	-23°C	-25°F	-10°F	165°C	40°C
140°F		-18°C	-23°C	0°F	-10°F	185°C	40°C
180°F		0°C	-23°C	32°F	-10°F	205°C	40°C
Thermometer 101C 195 to 305°C		Thermometer 102C 123 to 177°C		Thermometer 103C 148 to 202°C		Thermometer 104C 173 to 227°C	
200°C	40°C	125°C	35°C	150°C	35°C	175°C	34°C
250°C	40°C	140°C	35°C	165°C	35°C	190°C	38°C
300°C	40°C	155°C	35°C	180°C	35°C	205°C	40°C
		175°C	35°C	200°C	35°C	225°C	40°C
Thermometer 105C 198 to 252°C		Thermometer 106C 223 to 277°C		Thermometer 107C 248 to 302°C		Thermometer 108F 270 to 290°F	
200°C	40°C	225°C	40°C	250°C	45°C	275°F	
215°C	40°C	240°C	40°C	265°C	45°C	285°F	
230°C	40°C	255°C	41°C	280°C	45°C		
250°C	40°C	275°C	46°C	300°C	45°C		
Thermometer 109F 320 to 340°F		Thermometer 110C 133.6 to 136.4°C		Thermometer 110F 272.5 to 277.5°F		Thermometer 111C 170 to 250°C	
325°F		0°C		32°F		170°C	35°C
335°F		135°C		275°F		200°C	40°C
		136°C		277°F		250°C	45°C
Thermometer 112C 4 to 6°C		Thermometer 113C -1 to +175°C		Thermometer 113F 30 to 350°F		Thermometer 114C -80 to +20°C	
0°C		0°C		32°F		-75°C	
4°C		50°C		122°F		-60°C	
5°C		100°C		212°F		-40°C	
6°C		150°C		302°F		0°C	
		175°C		347°F			

TABLE 4 *Continued*

Temperature	Av Temp. of Emergent Mercury Column	Temperature	Av Temp. of Emergent Mercury Column	Temperature	Av Temp. of Emergent Mercury Column	Temperature	Av Temp. of Emergent Mercury Column
Thermometer 116C 18.9 to 25.1°C		Thermometer 117C 23.9 to 30.1°C		Thermometer 118C 28.6 to 31.4°C		Thermometer 118F 83.5 to 88.5°F	
every 1°C from 19.0°C		every 1°C from 24.0°C		0°C 30°C 31°C		32°F 86°F 88°F	
Thermometer 119C –38.3 to –30°C		Thermometer 119F –37 to –22°F		Thermometer 120C 38.6 to 41.4°C		Thermometer 121C 98.6 to 101.4°C	
–38°C 18°C –30°C 20°C 0°C 0°C		–36°F 64°F –22°F 68°F + 32°F 32°F		0°C 40°C 41°C		0°C 100°C 101°C	
Thermometer 122C –45 to –35°C		Thermometer 123C –35 to –25°C		Thermometer 124C –25 to –15°C		Thermometer 125C –15 to –5°C	
–45°C –40°C –35°C		–35°C –30°C –25°C		–25°C –20°C –15°C		–15°C –10°C –5°C	
Thermometer 126C –27.4 to –24.6°C		Thermometer 126F –17.5 to –12.5°F		Thermometer 127C –21.4 to –18.6°C		Thermometer 128C –1.4 to +1.4°C	
–27°C –26.1°C 0°C		–17°F –15°F 32°F		–21°C –20°C 0°C		0°C 1°C	
Thermometer 128F 29.5 to 34.5°F		Thermometer 129C 91.6 to 94.4°C		Thermometer 129F 197.5 to 202.5°F		Thermometer 130C –7 to +105°C	
32°F 34°F		0°C 93.3°C 94°C		32°F 200°F 202°F		0°C 35°C 70°C 105°C	
Thermometer 130F 20 to 220°F		Thermometer 132C 148.6 to 151.4°C		Thermometer 133C –38 to +2°C		Thermometer 134C 144 to 156°C	
Thermometer 130F 20 to 220°F		Thermometer 132C 148.6 to 151.4°C		Thermometer 133C –38 to +2°C		Thermometer 134C 144 to 156°C	
–32°F 100°F 160°F 220°F		–0°C 150°C 151°C		–36 25°C –30 25°C –24 25°C –18 25°C –12 25°C –6 25°C 0 25°C			
32°F 100°F 160°F 220°F		0°C 150°C 151°C		–36 25°C –30 25°C –24 25°C –18 25°C –12 25°C –6 25°C 0 25°C		145°C 40°C 150°C 40°C 155°C 40°C	
Thermometer 136C –20 to +60°F		Thermometer 136F –5 to +140°F		Thermometer 137C 80 to 100°C			
–20°C –10°C 0°C 10°C 20°C 30°C 40°C 50°C 60°C		–5°F 15°F 32°F 60°F 85°F 110°F 135°F		80°C 30°C 90°C 30°C 100°C 30°C			

^A For verification and calibration of total immersion thermometers see Test Method E 77.

For Thermometers 1C, 1F, 2C, 2F, 3C, 3F, 23C, 24C, and 25C the emergent column temperatures correspond on the average with those attained in verification using equipment such as that described in Test Method E 77.

For all other thermometers listed, the emergent column temperatures are those attained when using the thermometers in the test equipment for which the thermometers were originally designed. In some cases these temperatures are markedly different from those realized during verification. Also in some instances, such as Thermometers 35C and 35F, the values may not seem reasonable. Analysis of the factors affecting emergent column temperatures in use will provide the explanation for such apparent inconsistencies.

^B This thermometer is especially sensitive to changes in emergent column temperatures because organic liquids are used as the thermometer fluid. As a means of

avoiding errors due to this cause the ice point should be taken at total immersion and the correction calculated for partial immersion by using the emergent stem correction formula given in Test Method E 77.

Part B—Enclosed-Scale Thermometer

16. Specifications

16.1 The thermometers shall conform to the detailed specifications given in Table 5 and the requirements given in Sections 17-24.

TABLE 5 Specifications for Enclosed Scale Thermometers

ASTM Number	115C-86
Range (nominal), °C	5 or 6
Graduation interval, °C	0.01
Adjustable range, °C	-10 to 120
Total length, max, mm	640
Length of main scale/ ^a (graduated length), mm	44 ± 4
Distance from bottom of bulb to lowest numbered graduation line, mm	200 to 240
Diameter of sheath (top portion) max, mm	16
External bulb diameter, max, mm	11
Bulb length, mm	30 to 50
Bulb shoulder length, max, mm	11
Bulb—dimension/bore ratio, max	$\beta e/d = 15$ (see Note 6) (see 9.2.3)

17. Type

17.1 The thermometers shall be of the enclosed-scale mercury-in-glass type with adjustable range.

18. Temperature Scale

18.1 Temperature differences indicated by the thermometers shall be in terms of the International Temperature Scale of 1990 (ITS-90)⁴ as adopted by the General Conference on Weights and Measures.

19. Immersion

19.1 To obtain the full precision of the thermometer for difference measurements, the ambient (stem) temperature and immersion depth must be the same in all measurements.

19.2 The thermometers are for use in a vertical position.

19.3 In order to measure Celsius- or kelvin-scale temperatures after the setting temperature has been determined at a given immersion depth by comparison with a standard, the thermometer must be used at the same immersion for all main scale readings obtained at this setting.

20. Glass

20.1 The bulb and sheath of the thermometer should preferably be made of the same type of thermometric glass. This glass shall be selected so that the finished thermometer meets the following requirements:

20.1.1 The bulb glass shall be stabilized by suitable heat treatment to ensure that the accuracy requirements of Section 23 can be met,

20.1.2 Strain in the glass shall be reduced to a level sufficient to minimize the possibility of fracture due to thermal or mechanical shock,

20.1.3 The accuracy of the reading shall not be impaired by devitrifying during manufacture, and

20.1.4 The meniscus shall be distorted as little as possible by striae or impurities in the glass.

21. Vacuum

21.1 The capillary above the mercury shall be evacuated, and the vacuum shall be such that no difficulty is experienced in rejoining the column after setting.

22. Construction

22.1 *Shape*—The thermometer shall be straight and have insofar as practical circular cross sections.

22.2 *Top Finish*—The top of the thermometer shall be closed by a suitable cap.

22.3 *Scale*—The graduated scale shall be of opal glass and shall be securely fastened to prevent relative displacement between the capillary and scale, and in such a way that it can freely expand in length.

22.4 *Capillary Tube*—The capillary tube shall be transparent, its inside shall be smooth, and its cross-sectional area in the scale portion shall not show variations from the average greater than 5 %. The bore shall be large enough in relation to the dimensions of the thermometer bulb to ensure that (without tapping), the jumping of the meniscus does not exceed one half of the smallest scale division when the temperature is rising at a uniform rate not exceeding 0.05°C/min.

NOTE 85—According to Hall and Leaver, this condition can be achieved or bettered by keeping the ratio $\beta e/d < 15$.⁶ The external pressure coefficient is defined by the expression

$$\beta e = 0.52 D_e^2 / (D_e^2 - D_i^2) \quad (1)$$

where:

d = bore of the capillary, mm,

βe = external pressure coefficient, m-deg C/cm,

D_e = external diameter of the thermometer bulb, and

D_i = internal diameter of the thermometer bulb.

22.5 *Adjusting Device*—For adjusting the amount of mercury in the bulb and main capillary to the intended range, an enlargement shall be provided above the measuring capillary to serve as a reservoir for the separated mercury. Adjustment shall be possible without difficulty. To facilitate adjustment of the range an auxiliary scale may be provided. Two designs of adjusting devices are indicated in Fig. 12. Operation of the adjusting device shall require a temperature of approximately, but not less than, 35°C above the setting point.

22.6 *Dimensions*—The dimensions shall be as given in Table 5 and Fig. 12.

22.7 *Graduation and Figuring*:

22.7.1 The range of graduation of the thermometer shall be as specified in Table 5.

22.7.2 The graduation lines shall be clearly defined and of uniform thickness which should in no case exceed 0.05 mm. The lines shall be at right angles to the axis of the thermometer.

22.7.3 The thermometer shall be graduated and figured for use in a vertical position. The arrangement of the graduation

⁴Observations

⁴ "The International Temperature Scale of a reference point before and after the test give a measure 1990," Amended Edition of the degree of bulb stability achieved in manufacture, 1990, *Metrologia*, Vol 27, No. 1, 1990, pp. 3-15.

lines shall be as specified in Fig. 13. Each 0.1-deg line shall be a long line; each 0.05-deg line shall have a length of two thirds of the long line; and each 0.01-deg line shall have a length of one third of the long line. All graduation lines shall be readily visible from both sides of the capillary.

22.7.4 The scale shall be extended beyond the lowest long graduation line by from two to five scale divisions.

22.7.5 Figuring shall be as shown in Fig. 13. The lowest long graduation line in upward reading thermometers, and the highest long graduation line in downward reading thermometers shall be figured “0.” Each full degree shall be figured with large numbers. Every second intermediate one tenth of a degree shall be figured with small numbers on the right-hand side of the scale.

23. Interval Error

23.1 The interval error of each partial interval of a range of 0.5°C shall not exceed $\pm 0.01^\circ\text{C}$. The maximum error for any larger interval shall not exceed 0.02°C. These values refer to the adjustment of the thermometer to “0” at 20°C and at a temperature of the emergent stem of 20°C.

NOTE 96—The first part of this requirement essentially requires that calibration be performed at 0.5°C intervals. The need for this is indicated by findings at the National Institute of Standards and Technology that

calibration every 40 to 50 divisions is required for reliable interpolation to one or two tenths of a division.

23.2 The stability of the thermometer shall be such that the zero reading does not change by more than 0.01°C in 24 h when left at the setting temperature after the bulb of the thermometer has been heated for at least 15 min to a temperature 35°C above the setting point.

24. Inscriptions

24.1 The following inscriptions shall be permanently and legibly marked on the thermometer:

24.1.1 Temperature scale (abbreviations such as “°C” or “C”),

24.1.2 Bulb glass type (the glass may be identified by a colored stripe or stripes or by an inscription on the thermometer),

24.1.3 Identification number (manufacturer’s serial number),

24.1.4 Manufacturer’s tradename or mark, and

24.1.5 ASTM 115C.

25. Keywords

25.1 bulb; liquid-in-glass thermometers; standard specification; stem; temperature; thermometer

ASTM International takes no position respecting the validity of any patent rights asserted in connection with any item mentioned in this standard. Users of this standard are expressly advised that determination of the validity of any such patent rights, and the risk of infringement of such rights, are entirely their own responsibility.

This standard is subject to revision at any time by the responsible technical committee and must be reviewed every five years and if not revised, either reapproved or withdrawn. Your comments are invited either for revision of this standard or for additional standards and should be addressed to ASTM International Headquarters. Your comments will receive careful consideration at a meeting of the responsible technical committee, which you may attend. If you feel that your comments have not received a fair hearing you should make your views known to the ASTM Committee on Standards, at the address shown below.

This standard is copyrighted by ASTM International, 100 Barr Harbor Drive, PO Box C700, West Conshohocken, PA 19428-2959, United States. Individual reprints (single or multiple copies) of this standard may be obtained by contacting ASTM at the above address or at 610-832-9585 (phone), 610-832-9555 (fax), or service@astm.org (e-mail); or through the ASTM website (www.astm.org).

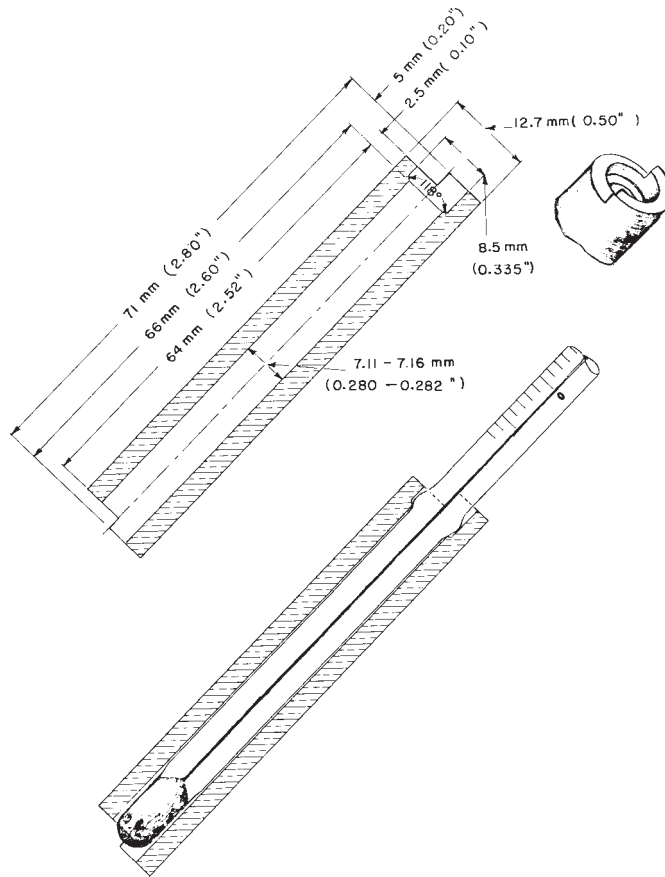

FIG. 1 Test Gage for Checking Enlargements on Thermometers 9C, 9F, 10C, 10F, 57C, 57F, 88C, and 88F

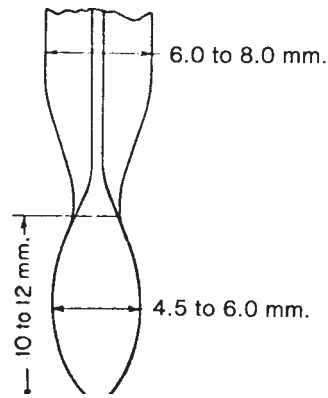

FIG. 2 Bulb of ASTM Congealing Point Thermometers 54C and 54F

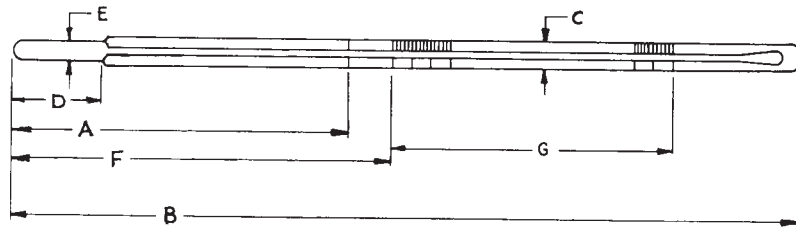

FIG. 3

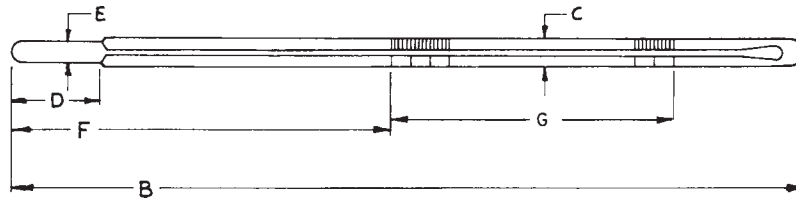

FIG. 4

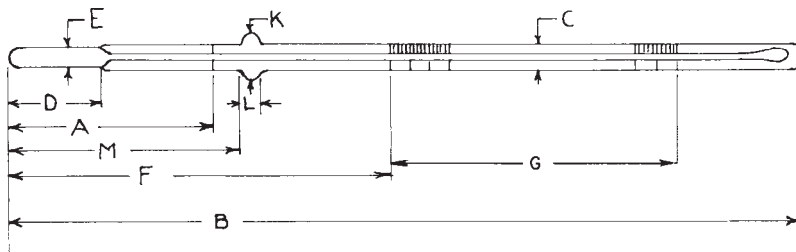

FIG. 5

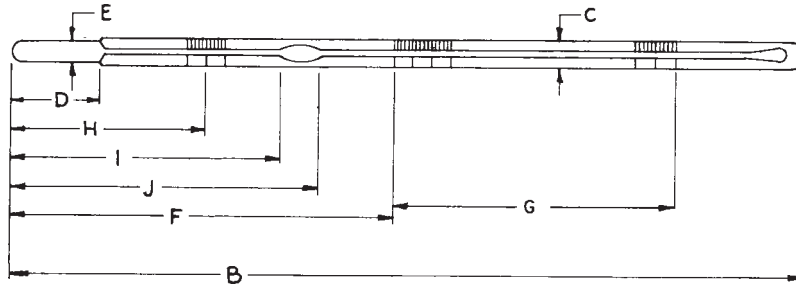

FIG. 6

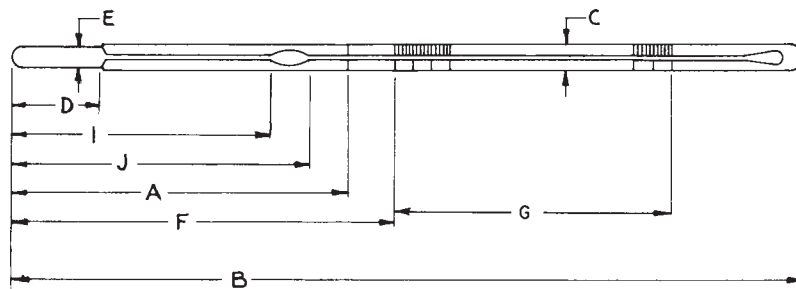

FIG. 7

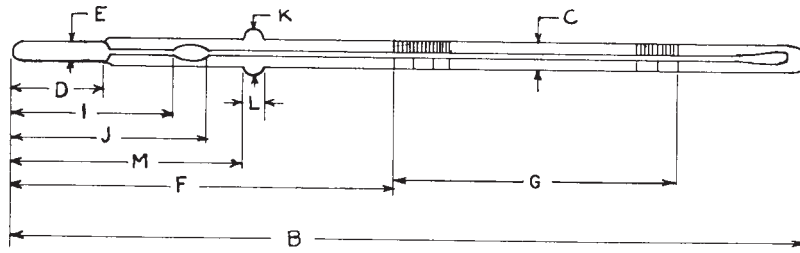

FIG. 8

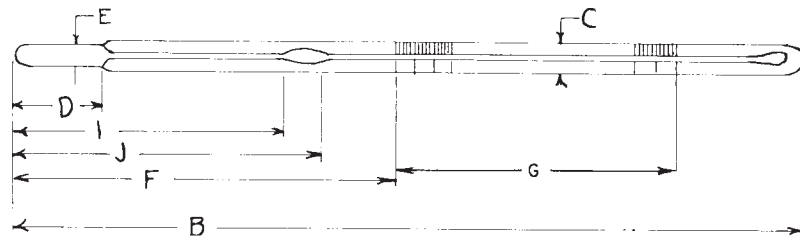

FIG. 9

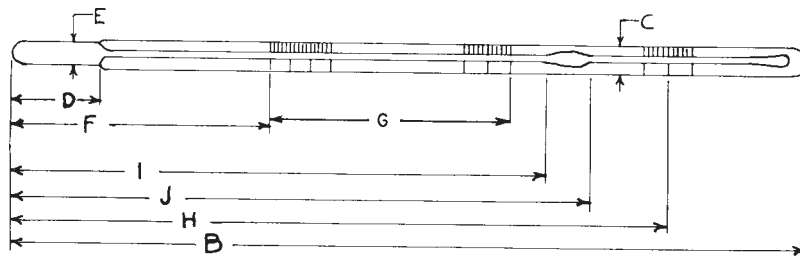

FIG. 10

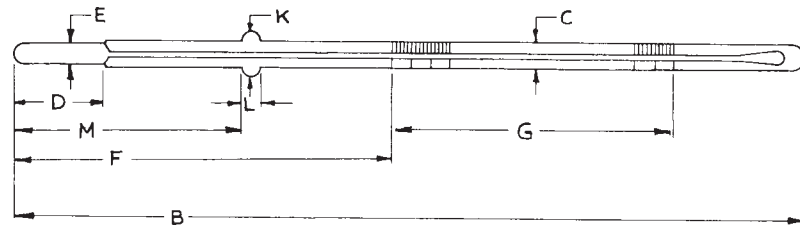
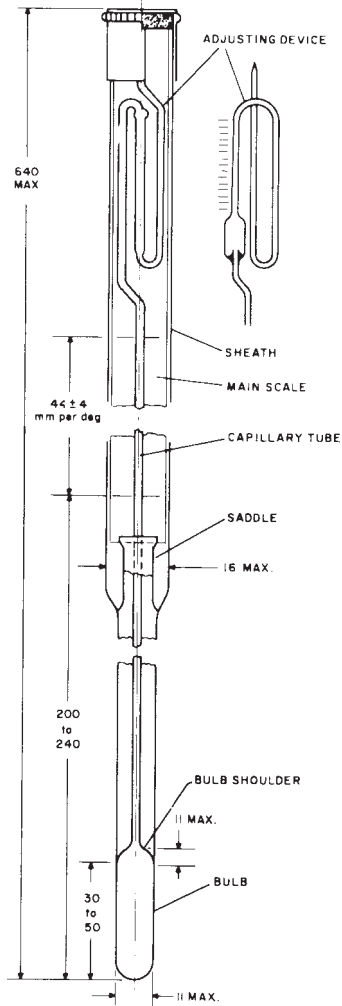

FIG. 11



NOTE 1—All dimensions are in millimetres.

FIG. 12 Enclosed Scale Adjustable Range Thermometers

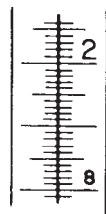

FIG. 13 Graduation and Figuring

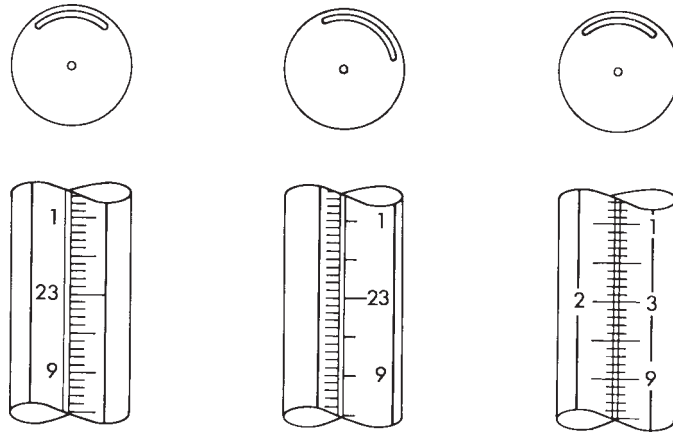

FIG. 14 Schemes for Graduation and Figuring