



# Standard Test Methods for Resistance of Glass Containers to Chemical Attack<sup>1</sup>

This standard is issued under the fixed designation C 225; the number immediately following the designation indicates the year of original adoption or, in the case of revision, the year of last revision. A number in parentheses indicates the year of last reapproval. A superscript epsilon ( $\epsilon$ ) indicates an editorial change since the last revision or reapproval.

*This standard has been approved for use by agencies of the Department of Defense.*

## 1. Scope

1.1 These test methods cover the evaluation of the resistance of glass containers to chemical attack. Three test methods are presented, as follows:

1.1.1 *Test Method B-A* covers autoclave tests at 121°C on bottles partially filled with dilute acid as the attacking medium.

1.1.2 *Test Method B-W* covers autoclave tests at 121°C on bottles partially filled with distilled water as the attacking medium.

1.1.3 *Test Method P-W* covers autoclave tests at 121°C on powdered samples with pure water as the attacking medium.

1.2 The values stated in SI units are to be regarded as the standard. The values in parentheses are for information only.

1.3 *This standard does not purport to address all of the safety concerns, if any, associated with its use. It is the responsibility of the user of this standard to establish appropriate safety and health practices and determine the applicability of regulatory limitations prior to use.*

## 2. Referenced Documents

### 2.1 ASTM Standards:

A 569/A 569M Specification for Steel, Carbon (0.15 Maximum Percent), Hot-Rolled Sheet and Strip Commercial Quality<sup>2</sup>

D 1125 Test Methods for Electrical Conductivity and Resistivity of Water<sup>3</sup>

D 1193 Specification for Reagent Water<sup>3</sup>

E 11 Specification for Wire-Cloth Sieves for Testing Purposes<sup>4</sup>

E 691 Practice for Conducting an Interlaboratory Study to Determine the Precision of a Test Method<sup>4</sup>

## 3. Significance and Use

3.1 The solubility of glass in contact with food, beverages, or pharmaceutical products is an important consideration for the safe packaging and storage of such materials. Autoclave

conditions are specified since sterilization is often employed for the packaging of the product. It also represents one of the most extreme conditions, particularly of temperature, that containers will ordinarily experience. Any of the three test methods described may be used to establish specifications for conformity to standard values, either as specified by a customer, an agency, or “The United States Pharmacopeia.”

3.1.1 *Test Method B-A* is intended particularly for testing glass containers primarily destined for containment of products with a pH under 5.

3.1.2 *Test Method B-W* is intended particularly for testing glass containers to be used for products with a pH of 5.0 or over.

3.1.3 *Test Method P-W* is a hydrolytic autoclave test primarily intended for evaluating samples from untreated glass containers. It is often useful for testing the resistance of containers of too small capacity to permit measurements of solubility on the unbroken article by the B-W test method. Yielding the water resistance of the bulk glass, it can also be used in conjunction with the B-W test method to distinguish whether the internal surface of a container has been treated to improve its durability.

3.2 All three test methods are suitable for specification acceptance.

## 4. Purity of Reagents

4.1 Reagent grade chemicals shall be used in all tests. Unless otherwise indicated, it is intended that all reagents shall conform to the specifications of the Committee on Analytical Reagents of the American Chemical Society, where such specifications are available.<sup>5</sup> Other grades may be used, provided it is first ascertained that the reagent is of sufficiently high purity to permit its use without lessening the accuracy of the determination.

4.2 Unless otherwise indicated, references to water shall be understood to mean distilled water or other water meeting the requirements for one of the types of reagent water covered by Specification D 1193.

<sup>1</sup> These test methods are under the jurisdiction of ASTM Committee C-14 on Glass and Glass Products and are the direct responsibility of Subcommittee C14.03 on Chemical Properties.

Current edition approved July 26, 1985. Published September 1985. Originally published as C 225 – 49 T. Last previous edition C 225 – 85 (1994)<sup>1</sup>.

<sup>2</sup> *Annual Book of ASTM Standards*, Vol 01.03.

<sup>3</sup> *Annual Book of ASTM Standards*, Vol 11.01.

<sup>4</sup> *Annual Book of ASTM Standards*, Vol 14.02.

<sup>5</sup> *Reagent Chemicals, American Chemical Society Specifications*, American Chemical Society, Washington, DC. For suggestions on the testing of reagents not listed by the American Chemical Society, see *Analar Standards for Laboratory Chemicals*, BDH Ltd., Poole, Dorset, U.K., and the *United States Pharmacopeia and National Formulary*, U.S. Pharmacopeial Convention, Inc. (USPC), Rockville, MD.

## TEST METHOD B-A—RESISTANCE OF BOTTLES TO ATTACK BY DILUTE ACID

### 5. Apparatus

5.1 *Autoclave or Steam Sterilizer*, capable of withstanding a pressure of 165 kPa (24 psi) and, preferably, equipped with a constant-pressure regulator or other means for maintaining the temperature at  $121 \pm 0.5^\circ\text{C}$  ( $250 \pm 0.9^\circ\text{F}$ ). This temperature shall be checked by means of a suitably calibrated instrument. The autoclave shall be capable of accommodating at least six and preferably twelve of the largest containers to be tested. It shall be equipped with a rack for supporting the samples, a thermometer, a pressure gage, and a vent cock.

### 6. Reagents and Materials

6.1 *Acetone*, USP grade.

6.2 *Methyl Red Indicator Solution*—Dissolve 24 mg of the sodium salt of methyl red in 100 mL of water. If necessary, neutralize the indicator solution with 0.020*N* sodium hydroxide (NaOH) solution so that the titer of five drops of the indicator solution in 100 mL of the special distilled water does not exceed 0.02 mL of 0.020*N* NaOH solution. In titrations using the methyl red indicator solution, the end point shall be taken at a pH of 5.6.

6.3 *Phenolphthalein Indicator Solution*—Dissolve 0.5 g of phenolphthalein in 60 mL of ethyl alcohol (95 %) and dilute with water to 100 mL.

6.4 *Sodium Hydroxide Solution, Standard (0.020*N*)*—Dissolve 100 g of NaOH in 100 mL of water in a 150-mL test tube. Avoid wetting the top of the test tube. Stopper the tube loosely with a stopper covered with tinfoil and allow to stand in a vertical position until the supernatant liquid is clear. Withdraw some of the clear solution in a measuring pipet and deliver 1.3 mL into a paraffin-lined bottle containing 1 L of carbon dioxide (CO<sub>2</sub>)-free water. Stopper the bottle with a two-hole stopper carrying a glass siphon tube (for delivering the solution to a buret) and a soda-lime or soda-asbestos guard tube. Standardize the 0.020*N* NaOH solution against the National Institute of Standards and Technology Standard Sample No. 84h of acid potassium phthalate. Transfer 0.2000 g of the phthalate to a 250-mL Erlenmeyer flask and dissolve in about 75 mL of CO<sub>2</sub>-free water. Add five drops of phenolphthalein indicator solution and titrate with the NaOH solution to the first persistent pink color. Adjust the standard NaOH solution to 0.020*N* strength.

6.4.1 Calculate the normality *N* of the NaOH solution as follows:

$$N = 0.9798/\text{mL of NaOH} \quad (1)$$

6.5 *High-Purity Water*—This water shall be free of heavy metals, particularly copper, as shown by a dithizone test<sup>6</sup> and have a conductivity (consult Test Methods D 1125) not exceeding 0.15 μS/cm.

6.5.1 The source water shall be distilled, then passed through a deionizer cartridge packed with a mixed bed of

nuclear-grade resin,<sup>7</sup> then through a cellulose ester membrane having openings not exceeding 0.45 μm.<sup>8</sup> Pass the purified water through an in-line conductivity cell to verify its purity. After flushing discharge lines, suitable water should be dispensed directly into the test vessels.

NOTE 1—Copper tubing should not be used in the discharge lines. TFE-fluorocarbon or pure tin are suitable.

NOTE 2—Reference should be made to Specification D 1193. Type I reagent water as defined therein complies with the present 6.5. In the interest of practicality and demonstrated sufficiency, 6.5 allows the following deviations from Type I reagent water specifications.

(1) Source water is unspecified whereas Type I specifies source water having a maximum conductivity of 20 μS/cm at 25°C.

(2) The final step is filtration through a membrane having openings not exceeding 0.45 μm. Type I directs filtration through a 0.2-μm membrane.

(3) The conductivity immediately before dispensing is required not to exceed 0.15 μS/cm at 25°C whereas Type I is limited to 0.06 μS/cm at 25°C.

The distillation step is essential to minimize or avoid cultivation of microorganisms in the ion-exchange bed and consequent clogging of the membrane filter. When preceded by distillation, the ion-exchange bed should have a long life, but as the conductivity begins to rise toward the limit it should be replaced by a new bed.

Distillation from phosphoric acid with a conductivity of the product between 0.5 and 1.0 μS/cm was specified as water for extraction in Test Methods C 225. Water prepared as described herein gave results averaging about 8 % higher than water prepared by distillation from phosphoric acid when Test Method B-W was applied to soda-lime and borosilicate glass bottles in seven laboratories. The trend to slightly greater extraction may be associated with the higher average purity of this water. The limit on conductivity of 0.15 μS/cm for water prepared by this means was set because water of less conductivity is readily obtained and when 0.15 μS/cm is exceeded, the conductivity rises rapidly on further use of the system.

6.6 *Sulfuric Acid, Standard (0.020*N*)* containing approximately 0.58 mL of concentrated sulfuric acid (H<sub>2</sub>SO<sub>4</sub>, sp gr 1.84) in 1 L of solution. Prepare 0.1*N* H<sub>2</sub>SO<sub>4</sub> containing 3.0 mL of concentrated sulfuric acid (H<sub>2</sub>SO<sub>4</sub>, sp gr 1.84)/L. Dilute 200 mL of the 0.1*N* H<sub>2</sub>SO<sub>4</sub> to 1 L and standardize against 0.020*N* NaOH solution, using methyl red indicator solution. Finally, adjust the standard H<sub>2</sub>SO<sub>4</sub> to 0.020*N* strength.

6.7 *Sulfuric Acid, Standard (0.0005*N*)*—Mix 1 volume of 0.1*N* H<sub>2</sub>SO<sub>4</sub> with 199 volumes of water. Adjust the strength to be  $0.0005 \pm 0.000025*N*$ .

6.8 *Sulfuric Acid, Standard (0.0002*N*)*—Mix 1 volume of 0.1*N* H<sub>2</sub>SO<sub>4</sub> with 499 volumes of water. Adjust the strength to be  $0.0002 \pm 0.00001*N*$ .

### 7. Preparation of Sample

7.1 If the bottles are 168-cm<sup>3</sup> (6-oz) capacity or over, select three bottles. If the bottles are smaller than 6-oz capacity, select a sufficient number so the contents can be combined to form

<sup>7</sup> A nuclear-grade resin mixture of the strong acid cation exchanger in the hydrogen form and the strong base anion exchanger in the hydroxide form with a one-to-one cation to anion equivalence ratio, such as that available from the Millipore Corp., 80 Ashby Rd., Bedford, MA 01730; Barnstead Co., 225 Rivermoor St., Boston, MA 02131; Illinois Water Treatment Co., 854 Cedar St., Rockford, IL 61105; or Vaponics, Inc., 200 Cordage Park, Plymouth, MA 02360, has been found satisfactory for this purpose.

<sup>8</sup> An in-line filter such as those made by the Millipore Corp., Gelman Instrument Co., 600 S. Wagner Rd., Ann Arbor, MI 48106; and Schleicher and Schuell, Inc., 540 Washington St., Keene, NH 10003 has been found satisfactory for this purpose.

<sup>6</sup> Feigl, Fritz, "Spot Tests in Inorganic Analysis," D. Van Nostrand Co., Inc., Princeton, NJ, 1958, p. 90; H. J. Wichman, "Isolation and Determination of Traces of Metals," *Industrial and Engineering Chemistry*, Vol 11, No. 2, 1939, pp. 67–72.

three sets to give 100 mL/set. Rinse each container with two portions of the high-purity water, follow with two similar rinsings using acetone and dry with a stream of clean dry air.

## 8. Procedure

8.1 Fill the containers, at room temperature, to 90 % of overflow capacity with the attacking medium.

NOTE 3—If the bottles to be tested will neutralize more than the equivalent of 0.80 mL of 0.020*N* H<sub>2</sub>SO<sub>4</sub>, use 0.0005*N* H<sub>2</sub>SO<sub>4</sub> as the attacking medium. Otherwise, use 0.0002*N* H<sub>2</sub>SO<sub>4</sub> as the attacking medium.

8.2 Cover each container individually with a chemical-resistant glass<sup>9</sup> beaker or cap that has been digested with water for at least 24 h at 90°C (194°F) or 1 h at 121°C (250°F). These covers shall be of such size that the bottoms of the beakers or caps fit snugly down on the top rims of the containers. Place the containers on the rack in the autoclave. The sample rack must support the samples above water level. Close the cover securely, leaving the vent cock open. Heat until steam issues vigorously from the vent. Allow steam to issue from the vent for 10 min; then close the vent cock and increase the temperature at the rate of 1°C/min to 121°C taking 19 to 23 min. Maintain the temperature at 121 ± 0.5°C (250 ± 0.9°F) for 1 h, counting from the time when the holding temperature is reached. At the end of the hour, cool at the rate of 0.5°C/min to atmospheric pressure, venting to prevent formation of a vacuum. The time to cool from 121°C to atmospheric pressure should be from 38 to 46 min. Open the autoclave and remove the containers.

8.3 *Titration of Bottle Extract*—Cool the containers and contents to room temperature. With a pipet, transfer 100-mL portions of the test solution from the containers to 250-mL flasks of chemical-resistant glass.<sup>9</sup> Add five drops of methyl red indicator solution to each flask and titrate with 0.20*N* NaOH solution.

NOTE 4—When titrations are under 1 mL, a microburet should be used.

## 9. Calculation and Report

9.1 Report the results as millilitres of 0.020*N* acid consumed in the test, *A*. Calculate as follows:

$$A = V - 0.98B \quad (2)$$

where:

*V* = 0.020*N* NaOH solution equivalent to 100 mL of the attacking medium, mL;

*B* = 0.020*N* NaOH solution used in the titration of 100 mL of bottle extract, mL; and

0.98 = factor applied to the titration of the bottle extract to correct that titration for loss of attacking medium during cooling of the autoclave.

## TEST METHOD B-W—RESISTANCE OF BOTTLES TO ATTACK BY WATER

### 10. Apparatus

10.1 See Section 5.

<sup>9</sup> Corning Pyrex-brand, manufactured by Corning Inc., Corning, NY 14831, Kimble Kimax-brand, manufactured by Kimble Glass, Inc., Crystal Ave., Vineland, NJ 08360, and similarly resistant borosilicate glass have been found satisfactory for this purpose.

### 11. Reagents

11.1 See 6.2-6.6.

### 12. Preparation of Sample

12.1 If the bottles are 168-cm<sup>3</sup> (6-oz) capacity or over, select three bottles. If the bottles are smaller than 168-cm<sup>3</sup> capacity, select a sufficient number so that the contents can be combined to form three sets to give 100 mL/set. Rinse each container with two portions of the high-purity water as described in 6.5.

### 13. Procedure

13.1 Fill the containers, at room temperature, to 90 % of overflow capacity with the high-purity water. Continue as described in 8.2.

13.2 *Titration of Bottle Extract*—Using a graduated cylinder, transfer 100-mL portions of the test solution from the containers to 250-mL flasks of chemical-resistant glass.<sup>9</sup> Add five drops of methyl red indicator solution to each flask and titrate with 0.020*N* H<sub>2</sub>SO<sub>4</sub> (Note 4). The time elapsing between opening the autoclave and titrating the solution should not exceed 1 h.

13.3 *Blank*—Titrate 100 mL of the high-purity water at the same temperature and using the same amount of indicator as in titration of the bottle extract in accordance with 13.2.

### 14. Calculation and Report

14.1 Report the results as millilitres of 0.020*N* H<sub>2</sub>SO<sub>4</sub> required for titration of the sample, minus millilitres required for titration of the blank.

## TEST METHOD P-W—RESISTANCE OF POWDERED SAMPLE TO ATTACK BY WATER

### 15. Apparatus

15.1 *Autoclave*—See 5.1.

15.2 *Flasks*—Erlenmeyer flasks of 250-mL capacity, made of chemical-resistant glass<sup>9</sup> and suitably aged by previous treatment similar to the test or by previous use.

15.3 *Crushing Device*—Either a special steel mortar or a special steel jar mill may be used as alternative means of preparing a crushed sample of glass.

15.3.1 *Mortar*—A hardened steel mortar of special design made in accordance with Fig. 1, and a hammer weighing about 0.9 kg (2 lbs).

15.3.2 *Jar Mill*—A jar rolling mill, or equivalent, capable of giving a jar speed of 90 to 95 r/min (see Fig. 2 and Fig. 3) and conforming to Specification A 569. This jar shall be an unlined steel jar with lifter bars, a 1.89-L (0.5-gal) capacity, and dimensions shown in Fig. 4. The jar closure shall be replaced with 30- by 30-mesh stainless steel wire screen.<sup>10</sup> The jar shall

<sup>10</sup> Jar, steel balls, and suitable jar mill, available from Norton Co., 120 Front St., Worcester, MA 01608, and Type 304 stainless steel wire mesh, available from W. S. Tyler Inc., P.O. 8900, Dept. T, Gastonia, NC 28053, have been found satisfactory for this purpose.

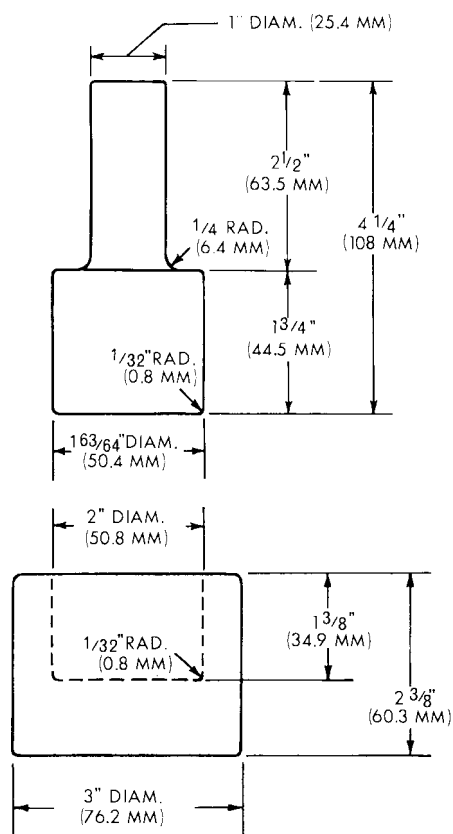

FIG. 1 Special Steel Mortar

## 16. Reagents

16.1 See 6.2-6.6.

## 17. Preparation of Sample

17.1 Take a sufficient number of containers at random and crush them to pieces not over 25 mm (1 in.) in size.

17.2 Crush the sample further either in the mortar or the ball mill.

17.2.1 *Mortar Crushing*—Place 30 to 40 g of the coarsely crushed sample in the special steel mortar (Fig. 1) and insert the pestle. Place the assembly on a firm support and strike it sharply with three or four hammer blows. During the operation it is strongly urged that the operator wear safety glasses. Empty the contents of the mortar into the assembled nest of sieves. Repeat the crushing operation until a 100-g sample has been added to the nest of sieves. Shake the sieves for a short time by hand, and then remove the glass from the 850- and 425- $\mu\text{m}$  (Nos. 20 and 40) sieves and recrush and sieve it as before. Again remove the glass from the 850- and 425- $\mu\text{m}$  sieves and repeat the crushing and sieving operations for the third time. Empty the receiving pan, reassemble the nest of sieves, and shake on the mechanical sieve shaker for 5 min, or shake by hand for the equivalent length of time. Reserve for test the glass grains that pass the 425- $\mu\text{m}$  sieve and are retained on the 300- $\mu\text{m}$  (No. 50) sieve. There should thus be obtained a sample of the 40- to 50-mesh grains, in excess of 10 g. Keep the sample in a desiccator in a closed sample bottle until used.

17.2.2 *Jar-Mill Crushing*—The jar mill may be used as an alternative crushing means. Place approximately 300 g of the coarsely crushed glass in the steel jar (Fig. 4). For thin-wall tubing 100 g of coarsely crushed glass is sufficient. Add 40 clean steel balls to the jar. Assemble the stainless steel wire screen and O-rings. Rotate the jar at approximately 92 r/min for 7 min. Collect the crushed sample on a nest of sieves, sizes 425- and 300- $\mu\text{m}$  (Nos. 40 and 50), and a receiving pan. Shake on the mechanical shaker for 5 min or shake by hand for the equivalent length of time. Reserve for test the grains that pass the 425- $\mu\text{m}$  sieve and are retained on the 300- $\mu\text{m}$  sieve. The sample should be in excess of 10 g. Keep sample in a desiccator in a closed sample bottle until used.

NOTE 7—This crushing method may yield slightly lower test results than glass crushed by mortar and pestle, probably because of a cleaner sample.

17.3 Spread the sample on a piece of glazed paper and pass a magnet through it to remove particles of iron that may have been introduced during the crushing operation. Transfer the approximately 10-g sample to a 250-mL Erlenmeyer flask. Wash the sample by swirling for 30 s in 30 mL of acetone. Repeat this for five more 30-s washes in fresh acetone. At this point the sample should be free from agglomerations of glass powder and the surface of the grains should appear practically free of adhering fine particles. Place the flask and contents in the drying oven at 140°C (285°F) for 20 min. Remove, transfer the grains to a weighing bottle, close the bottle, and place in a desiccator to cool. The sample may be stored in the desiccator until the test is started, but not for more than 48 h.

## 18. Procedure

18.1 Transfer exactly 10 g of the prepared sample to a

be used in conjunction with polished AISI and SAE Specifications 1018 steel balls carburized and hardened to HRC 60 to 64.<sup>11</sup>

NOTE 5—Fabricate hood and trough around rolls of the jar mill (see Fig. 2 and Fig. 3). Use 20-gage polished stainless steel. The trough may be riveted to the frame. Friction fit of the hood permits removal for access to the jar. The jar position is fixed by a pointed 9.5- by 136.5-mm ( $\frac{3}{8}$ - by  $5\frac{3}{8}$ -in.) cold-rolled steel rod (*H*) that is welded to a 3.2-mm ( $\frac{1}{8}$ -in.) steel plate and attached to frame of jar mill (see Figs. 2 and 4). A 22- by 19-mm ( $\frac{7}{8}$ - by  $\frac{3}{4}$ -in.) cold-rolled steel rod (*G*) is welded to lock screw (*D*). The jar closure consists of 30-mesh stainless steel screen (*F*). The screen fits between rubber gasket (*B*) and plywood ring (*E*). Closure assembly is secured to jar by lock (*C*). Raise the back of the jar mill to provide 13° inclination of rollers and jar. This facilitates discharge of the crushed glass.

15.4 *Sieves*—A nest of 203-mm (8-in.) sieves with cover and pan, including the 850- $\mu\text{m}$  (No. 20), 425- $\mu\text{m}$  (No. 40), and 300- $\mu\text{m}$  (No. 50) sieves. The sieves shall conform to Specification E 11. Sieve wire, frames, pan, and cover shall be of stainless steel construction.

### 15.5 Mechanical Sieve Shaker.<sup>12</sup>

NOTE 6—If a mechanical sieve shaker is not available, the procedure makes provisions for sieving by hand.

15.6 *Drying Oven*—A laboratory drying oven suitable for operation at 140°C (285°F).

<sup>11</sup> SAE Handbook, Society of Automotive Engineers, 1972, pp. 7 and 54.

<sup>12</sup> The Ro-Tap Testing Sieve Shaker supplied by W. S. Tyler Co., has been found satisfactory for this purpose.

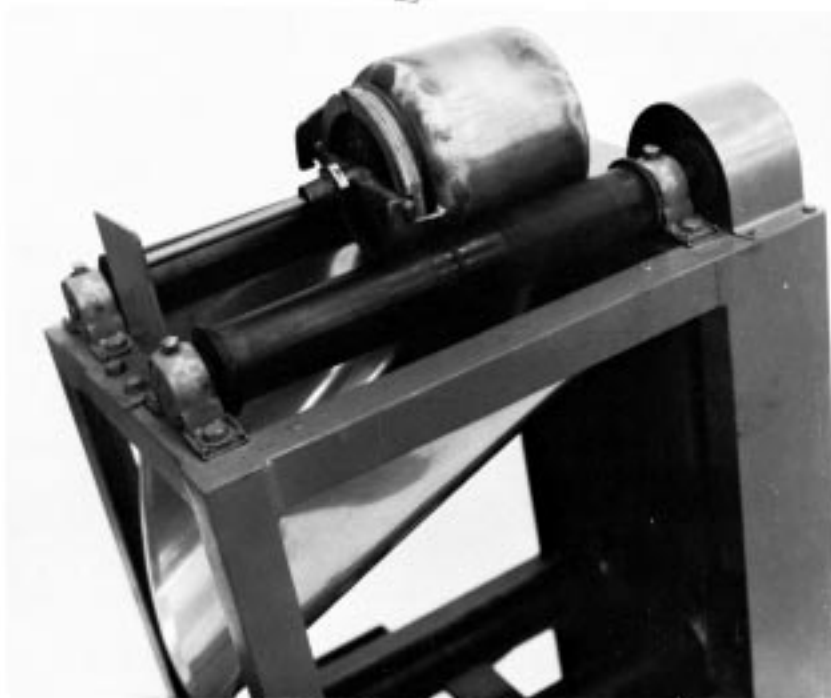

FIG. 2 Steel Jar Mill with Trough

250-mL Erlenmeyer flask that has once been digested with water for at least 24 h at 90°C (194°F) or 1 h at 121°C (250°F). Add to the sample in the flask exactly 50 mL of the high-purity water as in 6.5 from a pipet. Prepare a blank consisting of a 250-mL flask containing 50 mL of the high-purity water. Cover each flask with a chemical-resistant glass<sup>9</sup> beaker or cap that has been digested with distilled water. These covers shall be of such size that the bottoms of the beakers or caps fit snugly down on the top rims of the containers. Place the containers and blank on the rack in the autoclave. The sample rack shall support the samples above the water level. Close the cover securely, leaving the vent cock open. Heat until steam issues vigorously from the vent cock. Allow steam to issue from the vent for 10 min; then close the vent cock and increase the temperature at the rate of 1°C/min to 121°C, taking 19 to 23 min. Maintain the temperature at  $121 \pm 0.5^\circ\text{C}$  ( $250 \pm 0.9^\circ\text{F}$ ) for 30 min, counting from the time when the holding temperature is reached. At the end of the test period, cool at the rate of 0.5°C/min to atmospheric pressure, venting to prevent formation of a vacuum. The time to cool from 121°C to atmospheric pressure should be from 38 to 46 min. Remove the flasks from the autoclave.

18.2 *Titration of the Extract*—Cool the flasks in running water. Decant the water from the flask and wash the residual powdered glass with four 15-mL portions of high-purity water, adding the washings to the main portion. Add five drops of methyl red indicator solution and titrate immediately with 0.020N H<sub>2</sub>SO<sub>4</sub> from a microburet.

## 19. Calculation and Report

19.1 Report the number of millilitres of 0.020N H<sub>2</sub>SO<sub>4</sub> used to neutralize the extract from 10 g of glass, minus millilitres required for titration of the blank.

## 20. Precision and Bias<sup>13</sup>

### 20.1 Precision:

20.1.1 The data used to generate the measures of precision is the result of interlaboratory round robins. These measures are typical of the methods as applied to the glasses and bottles used in the round robins and are not all inclusive with respect to other types of glasses and bottles. The measures of precision were determined in accordance with procedures in Practice E 691. These measures are designated as follows:

20.1.1.1 *Repeatability*: the standard deviation for within-laboratory determinations.

20.1.1.2 *Reproducibility*: the standard deviation for between-laboratory determinations.

20.1.2 *Test Method B-A*—There is no data to support a statement concerning repeatability and reproducibility.

### 20.1.3 Test Method B-W:

20.1.3.1 Soda lime flint glass bottles, approximately 300-mL capacity, no internal surface treatment. Repeatability was 0.08 mL; reproducibility 0.16 mL. The average value calculated from the reported data was 1.65 mL acid per 100 mL of test solution.

20.1.3.2 Borosilicate glass bottles, approximately 300-mL capacity, no internal surface treatment. Repeatability was 0.01 mL; reproducibility was 0.02 mL. The average value calculated from the reported data was 0.03 mL acid per 100 mL of test solution.

### 20.1.4 Test Method P-W:

20.1.4.1 *NIST SRM 622* (soda lime flint glass). Repeatability was 0.14 mL; reproducibility was 0.21 mL. The average

<sup>13</sup> Supporting data are available from ASTM Headquarters. Request RR: C14-1000.



**FIG. 3 Steel Jar Mill with Hood and Trough**

value calculated from the reported data was 7.67 mL acid per 10 g of glass.

20.1.4.2 *NIST SRM 623* (borosilicate glass). Repeatability was 0.02 mL; reproducibility was 0.05 mL. The average value calculated from the reported data was 0.34 mL acid per 10 g of glass.

20.2 *Bias*—Standard glasses should be used wherever pos-

sible to determine bias of the results.

## **21. Keywords**

21.1 chemical attack; containers; durability; glass

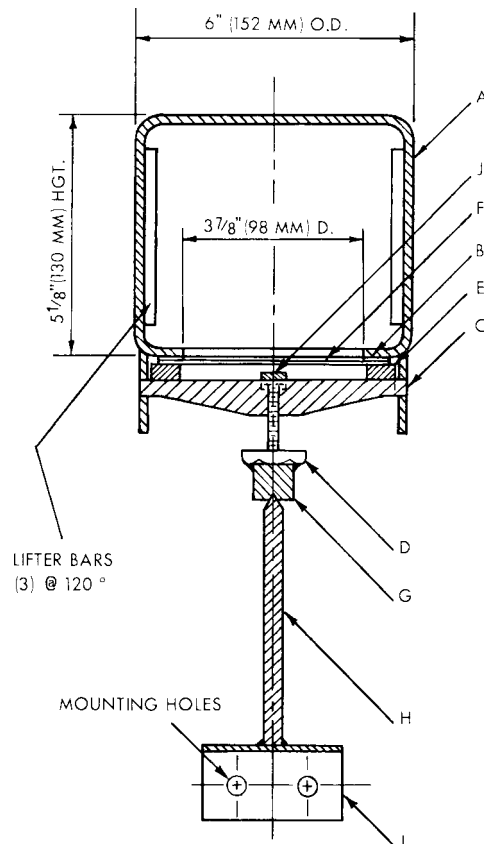

- A—Steel jar with lifter bars
- B—Rubber gasket—included with jar
- C—Lock—included with jar
- D—Lock screw—included with jar
- E—Plywood O-ring—133 mm (5¼ in.) in outside diameter by 102 mm (4 in.) in inside diameter by 19 mm (¾ in.) thick
- F—30-Mesh stainless steel screen—124-mm (4⅞-in.) diameter
- G—Steel rod—22.2-mm (⅞-in.) diameter by 19-mm (¾-in.) length
- H—Pointed steel rod—9.5-mm (⅜-in.) diameter by 137-mm (5⅝-in.) length
- I—Steel angle—41.3 by 108 by 6.4 mm (1⅝ by 4¼ by ¼ in.)
- J—Steel bar, slightly bent at center—4.8 mm (⅛ in.) thick by 12.7 mm (½ in.) wide by 133 mm (5¼ in.) long

**FIG. 4 Steel Jar**

The American Society for Testing and Materials takes no position respecting the validity of any patent rights asserted in connection with any item mentioned in this standard. Users of this standard are expressly advised that determination of the validity of any such patent rights, and the risk of infringement of such rights, are entirely their own responsibility.

This standard is subject to revision at any time by the responsible technical committee and must be reviewed every five years and if not revised, either reapproved or withdrawn. Your comments are invited either for revision of this standard or for additional standards and should be addressed to ASTM Headquarters. Your comments will receive careful consideration at a meeting of the responsible technical committee, which you may attend. If you feel that your comments have not received a fair hearing you should make your views known to the ASTM Committee on Standards, at the address shown below.

This standard is copyrighted by ASTM, 100 Barr Harbor Drive, PO Box C700, West Conshohocken, PA 19428-2959, United States. Individual reprints (single or multiple copies) of this standard may be obtained by contacting ASTM at the above address or at 610-832-9585 (phone), 610-832-9555 (fax), or service@astm.org (e-mail); or through the ASTM website (www.astm.org).