



Designation: D 4027 – 98

## Standard Test Method for Measuring Shear Properties of Structural Adhesives by the Modified-Rail Test<sup>1</sup>

This standard is issued under the fixed designation D 4027; the number immediately following the designation indicates the year of original adoption or, in the case of revision, the year of last revision. A number in parentheses indicates the year of last reapproval. A superscript epsilon ( $\epsilon$ ) indicates an editorial change since the last revision or reapproval.

### 1. Scope

1.1 This test method describes equipment and procedures to measure the shear modulus and shear strength of adhesive layers between rigid adherends. The equipment may also be used for determining the adhesive's shear creep compliance, the effects of strain history such as cyclic loading upon shear properties, and a failure criteria for biaxial stress conditions such as shear plus tension and shear plus compression.<sup>2</sup>

1.2 High-density wood shall be the preferred substrate. The practical upper limit on the shear modulus that can be measured is determined by the shear modulus of the adherends and by the strain measuring device. Thus, the practical limit of adhesive shear modulus that can be measured using high-density wood adherends is about 690 MPa ( $1 \times 10^5$  psi).

NOTE 1—Wood-base composites, metal, plastic, reinforced plastics, and other common construction materials may also be used for adherends.

1.3 The range of specimen dimensions that can be tested are: width 1.59 to 12.70 mm (0.0625 to 0.500 in.), length 102 to 203 mm (4 to 8 in.), and adherend thickness 13 to 25 mm (0.50 to 1.00 in.). The standard specimen dimensions shall be: width 3.18 mm (0.125 in.), length 203 mm (8 in.), and adherend thickness 19 mm (0.75 in.). Bondline thicknesses from 0.15 to 3.18 mm (0.006 to 0.125 in.) may be tested.

1.4 The values stated in SI units are to be regarded as the standard. The values given in parentheses are for information only.

1.5 *This standard does not purport to address all of the safety concerns, if any, associated with its use. It is the responsibility of the user of this standard to establish appropriate safety and health practices and determine the applicability of regulatory limitations prior to use.*

### 2. Referenced Documents

#### 2.1 ASTM Standards:

<sup>1</sup> This test method is under the jurisdiction of ASTM Committee D-14 on Adhesives and is the direct responsibility of Subcommittee D14.70 on Construction Adhesives.

Current edition approved May 10, 1998. Published March 1999. Originally published as D 4027 – 81. Last previous edition D 4027 – 93.

<sup>2</sup> Kreuger, G. P., "Tests for the Shear Properties of Adhesives in Adherend-Adhesive Assemblies," Unpublished report. Michigan Technological Institute, Houghton, MI.

D 905 Test Method for Strength Properties of Adhesive Bonds in Shear by Compression Loading<sup>3</sup>

D 907 Terminology of Adhesives<sup>3</sup>

D 4442 Test Methods for Direct Moisture Content Measurement of Wood and Wood-Base Materials<sup>4</sup>

E 83 Practice for Verification and Classification of Extensometers<sup>5</sup>

E 229 Test Method for Shear Strength and Shear Modulus of Structural Adhesives<sup>3</sup>

### 3. Terminology

3.1 *Definitions*—Many terms in this test method are defined in Terminology D 907.

3.1.1 *shear modulus, n*—the ratio of shear stress to corresponding shear strain below the proportional limit. (Compare *secant modulus*.)

3.1.1.1 *Discussion*—The term shear modulus is generally reserved for materials that exhibit linear elastic behavior over most of their stress-strain diagram. Many adhesives exhibit curvilinear or nonelastic behavior, or both, in which case some other term, such as secant modulus, may be substituted.

3.1.2 *shear strain, n*—the tangent of the angular change, due to force between two lines originally perpendicular to each other through a point in the body.

3.1.2.1 *Discussion*—Shear strain equals adherend slip/adhesive layer thickness.

3.1.3 *shear strength, n*—in an adhesive joint, the maximum average stress when a force is applied parallel to the joint.

3.1.3.1 *Discussion*—In most adhesive test methods, the shear strength is actually the maximum average stress at failure of the specimen, not necessarily the true maximum stress in the material.

#### 3.2 *Definitions of Terms Specific to This Standard:*

3.2.1 *load*—the force applied to the specimen at any given time.

3.2.2 *load-slip diagram*—a diagram in which corresponding values of load and slip are plotted against each other. Values of load are usually plotted as ordinates and values of slip as abscissas.

<sup>3</sup> *Annual Book of ASTM Standards*, Vol 15.06.

<sup>4</sup> *Annual Book of ASTM Standards*, Vol 04.10.

<sup>5</sup> *Annual Book of ASTM Standards*, Vol 03.01.



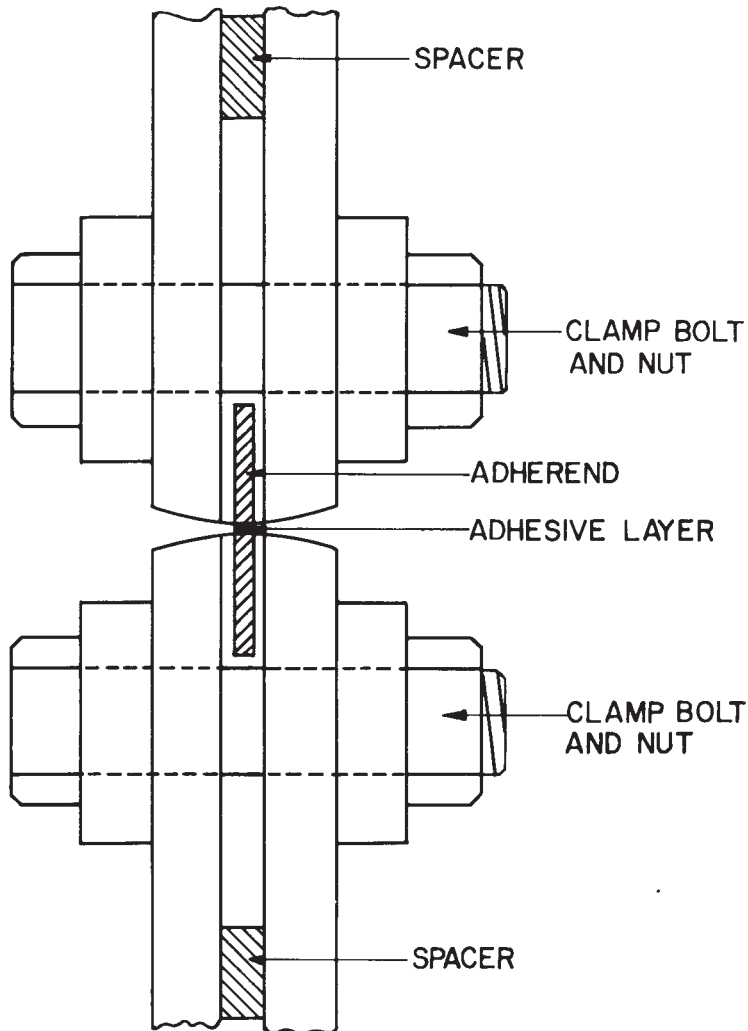

FIG. 2 Top View of the Rail Clamps Showing How the Specimen Is Gripped for Testing

4.3 The basic output of the test method is the bond shear strength determined as the shear stress at failure, and the stress-strain diagram determined from the plot of load on the shear tool versus the shear displacement of the bond line.

4.4 Bond strength and the stress-strain diagram may be obtained for a variety of environmental and loading conditions. Specific recommendations are made for a minimum test program.

**5. Significance and Use**

5.1 Structural design based on strength of materials principles or the theory of elasticity requires knowledge of the mechanical properties of the structural components, including adhesives. By the nature of their use, the most important adhesive properties are shear modulus and shear strength. A torsion test, such as described in Test Method E 229, is theoretically the most accurate method for measuring adhesive shear properties. It is, however, impractical in many situations. For example, certain materials of construction are not readily adaptable to fabricating the thin-walled cylinders used as

adherends in the torsion test. The modified-rail test does not have this disadvantage.

5.2 Two undesirable conditions occur in the modified-rail test specimens that do not occur in butt-joined cylinders; nonuniform shear-stress distribution along the joint, and the addition of some undefined combination of tension and compression stresses to the shear stress at a given location in the joint. The modified-rail shear tool minimizes but does not eliminate these undesirable effects.

5.3 Shear modulus, strength, and other properties are measured by the modified-rail method.

**6. Apparatus**

6.1 *Universal Testing Machine:*

6.1.1 The universal testing machine shall have a minimum load capacity of 8900 N (2000 lbf), and a range of crosshead speed from 0.317 to 10.16 mm/min (0.0125 to 0.40 in./min). A minimum vertical space of 508 mm (20 in.) and horizontal space of 305 mm (12 in.) is required to install the shear tool in the testing machine.

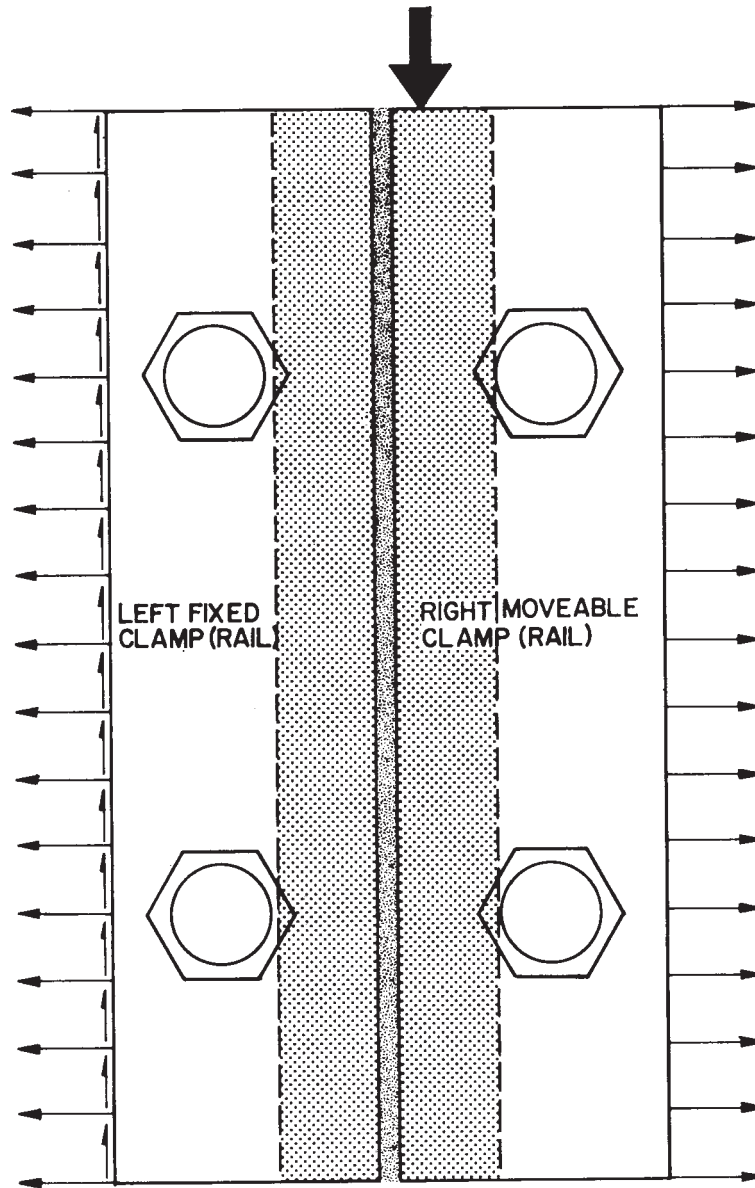

NOTE 1—During a shear only test the horizontal arrows (tension forces) would be absent.

FIG. 3 Side View of the Rail Clamps Showing the Forces On the Clamps (Specimen) During Combined Shear and Tension Loading

6.1.2 The testing machine shall have a device capable of reading the load to the nearest  $4.5 \pm 0.9$  N ( $1.0 \pm 0.2$  lbf). This readout device should preferably be an electronic load cell to facilitate simultaneous recording of load with the adhesive deformation.

6.2 Modified-Rail Shear Tool:

6.2.1 A shear tool suitable for this test method is illustrated in Fig. 1, Fig. 2, Fig. 4, Fig. 5, and Fig. 6.

6.2.2 The shear tool is fitted with a threaded bolt (Adjuster, Fig. 1<sup>6</sup>) to apply normal force for combined stress studies. The magnitude of the normal force is constant from the outset of the

test. The bolt has a strain gage bonded to it that, with a suitable readout device and calibration, can be used to set the desired normal force.

6.3 Slip or Strain Gage—Since the shear strain of adhesive layers will normally be very small, an ASTM Class A or Class B-1 extensometer as described in Practice E 83 shall be used. A mechanical-electrical transducer such as the linear variable differential transducer (LVDT) can be used to measure the shear slip indirectly by attachment of the LVDT to the specimen clamps. Or miniature electrical resistance strain gages can be used to measure the shear strain by direct attachment to the adhesive joint.

7. Materials

7.1 The adhesives used shall be selected by the adhesive manufacturer or by the party requesting these tests.

<sup>6</sup> Complete detail drawings of the modified-rail shear apparatus are available from the Forest Products Laboratory, Forest Service, U.S. Department of Agriculture, Madison, WI 53705.

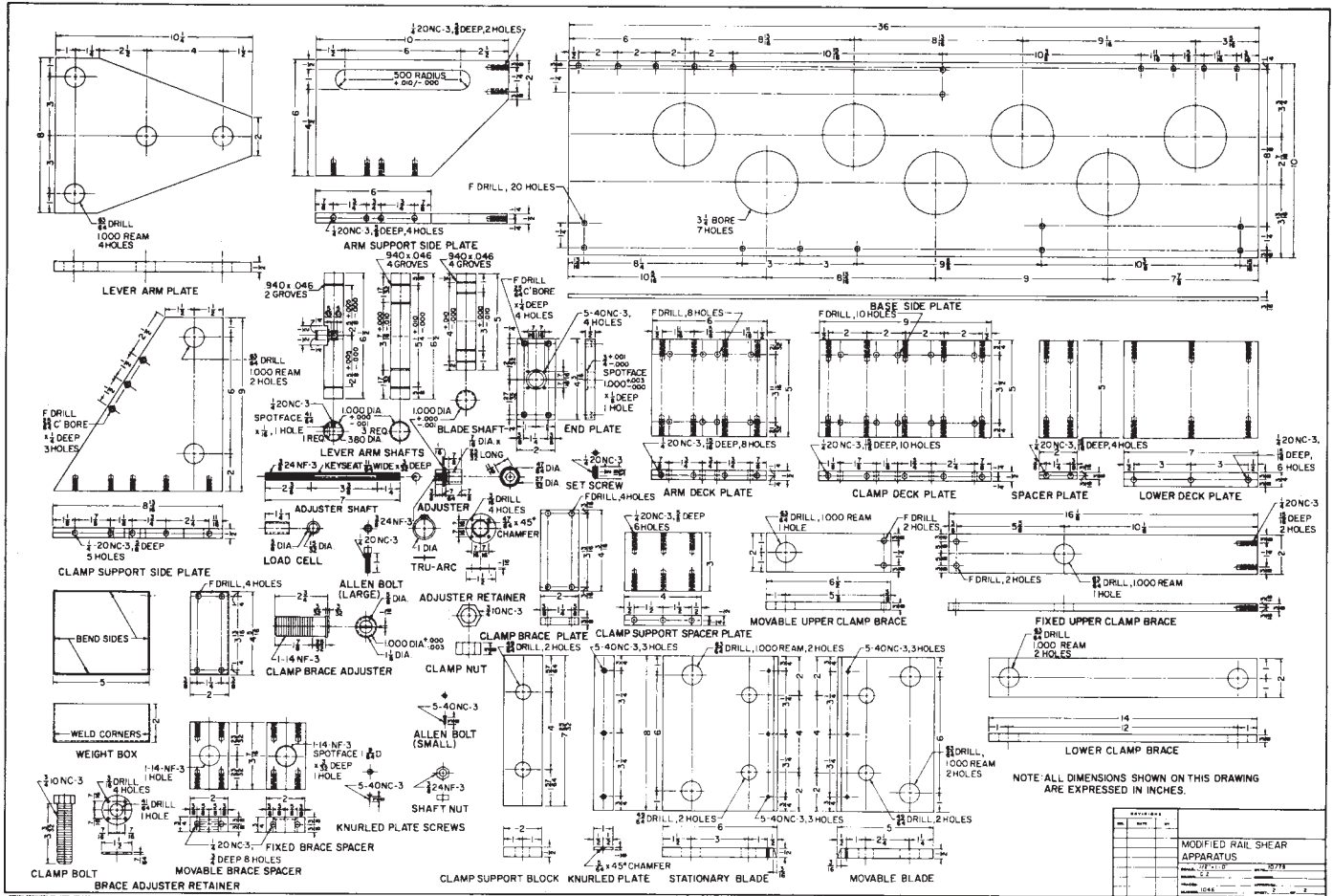

FIG. 4 Detail Drawings of Modified-Rail Shear Apparatus

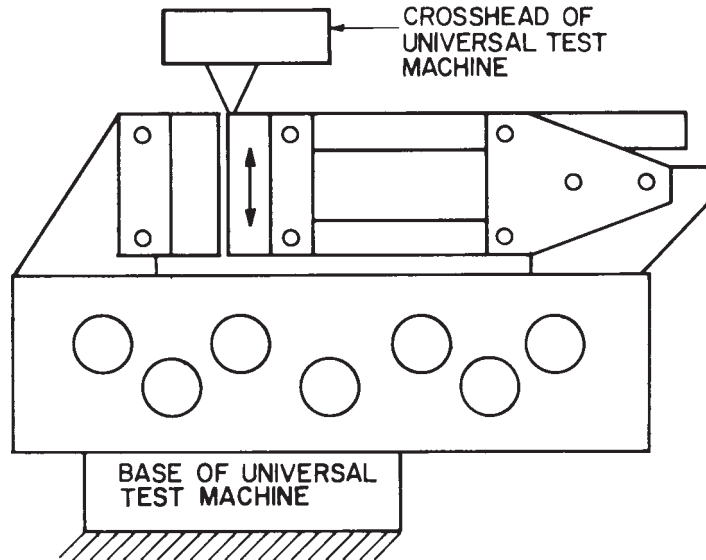

FIG. 5 Schematic Diagram Showing Use of the Modified-Rail Shear Apparatus With a Universal Test Machine to Apply Load

7.2 Hard maple shall be the standard material for specimen adherends. Other species may be selected at the option of the adhesive manufacturer or by the party requesting these tests.

7.2.1 Generally a high-density wood such as hard maple, yellow birch, Douglas-fir, or southern pine are desirable to minimize wood deformation effects on the measured adhesive

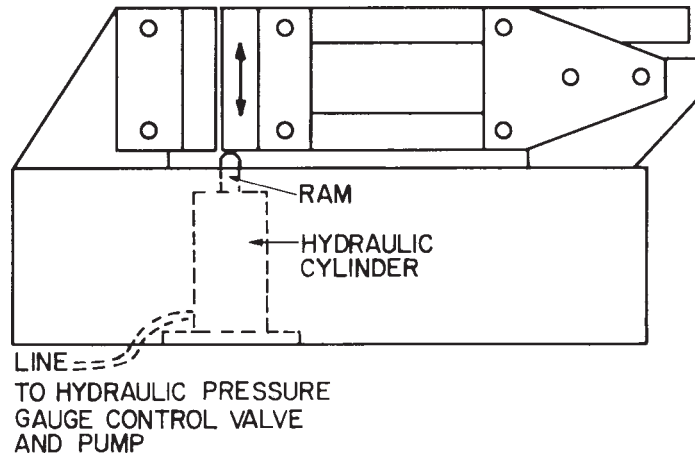

FIG. 6 Schematic Diagram Showing Use of the Modified-Rail Shear Apparatus With an Integral Hydraulic Cylinder to Apply Load

deformation. The specific gravity of the lumber selected shall equal or exceed average specific gravity for the species as given in Table 4-2 of the Wood Handbook.<sup>7</sup> For hard maple, the average is 0.63. A method of selecting maple lumber of satisfactory specific gravity is described in the appendix to Test Method D 905.

7.2.2 A uniform textured wood such as maple or birch is desirable to minimize wood density variation effects on the adhesive layer. Coarse-textured woods such as Douglas-fir, hemlock, or southern pine are acceptable however.

7.2.3 The wood shall be nominal 25.4 mm (1-in.) flat-sawn lumber presenting a flat grain (tangential surface) for bonding.

7.2.4 The lumber shall be straight-grained and free of defects including knots, cracks, abrupt grain deviations, decay, and any unusual discolorations within the bond area.

## 8. Sampling

8.1 When testing adhesives that form highly variable bondlines such as the solvent dispersed construction adhesives, prepare at least three billets for each test condition. Individual specimens cut from the billets shall be drawn at random for assignment to a given test condition.

8.2 Eight specimens shall be tested at every set of conditions.

## 9. Test Specimen

### 9.1 Specimen Dimensions:

9.1.1 The standard specimen dimensions are shown in Fig. 7. The thickness of the specimen may range from 1.59 to 12.7 mm (0.06 to 0.50 in.) at the discretion of the party requesting the tests.

9.1.2 The recommended bondline thickness shall be 0.79 mm (0.031 in.) with the following exceptions:

9.1.2.1 Bondline thickness may be varied when this test method is used to measure the effects of bondline thickness upon strength and shear modulus.

9.1.2.2 Bondline thickness shall never be greater than the adhesive manufacturer's stated maximum thickness.

9.1.3 The maximum range of bondline thickness that is acceptable for use in this test method is 0.15 to 3.18 mm (0.006 to 0.125 in.).

### 9.2 Specimen Preparation:

9.2.1 Cut the lumber into pieces measuring nominal 25 by 64 by 305 mm (1 by 2.5 by 12 in.) with the grain in the long direction. Lightly surface both faces of each piece. Condition these pieces to an equilibrium moisture content between 7 and 10 % (ovendry basis) or to the moisture content specified by the adhesive manufacturer. Determine moisture content at equilibrium from extra pieces of lumber in accordance with Procedure A of Test Methods D 4442.

9.2.2 Prepare one 64 by 305-mm (2.5 by 12-in.) surface of each board for bonding not longer than 2 days prior to bonding by lightly surfacing it with a hand-fed jointer. If a jig is used during gluing to control the bondline thickness, the pieces should be thickness planed on the opposite face to achieve the proper thickness for the jig and to ensure that the faces are parallel.

9.2.3 Follow the adhesive manufacturer's instructions when applying the adhesive and controlling the assembly time. Ensure that enough adhesive is applied, especially to thick joints to eliminate voids from this source.

9.2.4 To minimize variability along the specimen, control bondline thickness of gap-filling adhesives during assembly, pressing, and cure by the placement of shims in the bondline or by the use of a jig during cure. Describe the method of controlling thickness in the report.

NOTE 2—The method used to control bondline thickness may significantly affect the apparent shear properties of solvent-dispersed adhesives through its effect on the quantity and distribution of voids formed during solvent loss.

9.2.5 Cure the adhesive at room conditions, approximately 23°C (77°F) for 14 days; then further cure the adhesive at 60°C (140°F) for 12 h. This recommendation is not intended to override any special instructions for cure prescribed by the adhesive manufacturer or by the party requesting these tests.

<sup>7</sup> U.S. Forest Products Laboratory. *Wood Handbook: Wood as an Engineering Material*, USDA Agricultural Handbook 72, revised. U.S. Government. Printing Office, Washington, DC 20402, 1974.

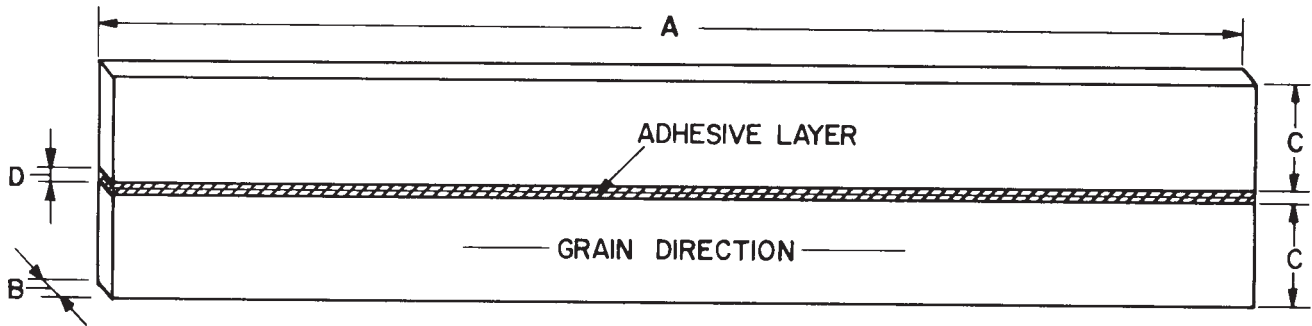

DIMENSIONS		
	INCH	MM
A	8	203
B	0.125	3.18
C	0.75	19.0
D	0.031	0.79

FIG. 7 Standard Test Specimen

9.2.6 After cure, cut eight 3.18-mm (0.125-in.) wide specimens from each bonded billet with a hollow-ground “planer saw blade.” Cut the individual specimens along the grain of the wood.

**10. Conditioning**

10.1 The temperature and moisture levels are primary variables affecting the strength and shear modulus of most adhesives. Use the temperature and moisture level specified by the adhesive manufacturer or the party requesting these tests. The standard conditions in the absence of other specifications are 23 ± 1°C (73 ± 2°F) and 50 ± 2 % relative humidity. Guidelines for conditions that typically occur in wood structures are shown in Table 1.

10.2 Condition the specimens at the specified temperature-humidity level(s) until they reach equilibrium as indicated by no progressive changes in weight.

**11. Procedure**

11.1 Immediately prior to testing, measure the bondline width and adhesive layer thickness of each specimen at the central and end points. Measure width with a dial-indicating micrometer graduated in 0.025 mm (0.001-in.) increments and thickness to the nearest 0.02 mm (0.0008 in.) using a microscope with a graduated eyepiece.

11.2 Clamp the specimen in the shear tool so that all of the adhesive layer is exposed and all of each adherend is within its respective clamp as shown in Fig. 4.

11.3 *Normal Force:*

11.3.1 The calibrated adjuster screw should be free so the level arm plate and movable clamp are free to move perpendicular to the bondline for tests of simple shear properties.

11.3.2 Apply the desired force perpendicular to the bondline with the calibrated adjuster screw located at the pivot end of

TABLE 1 Recommended Joint Formation and Test Conditions<sup>A</sup>

Variable	Recommended conditions
Adherend species	Douglas fir, hemlock, southern pine, <b>hard maple</b> , yellow birch
Moisture content at bonding (ovendry basis)	6 %, <b>15 %</b> , soaked
Method of bondline thickness control	<b>Shims left in</b> , shims removed, jig
Bondline thickness	0.10, <b>0.50</b> , 1.0, 2.0 mm
Cure temperature	5, <b>23</b> , 60°C
Cure time	7, 14, <b>28</b> , 56 days
Rate of crosshead travel	0.1, <b>1.0</b> , 10.0 mm/min.
Temperature at test	-17, <b>23</b> , 49, 70°C
Wood moisture level at test (ovendry basis)	<b>6 %</b> , 15 %, soaked
Cyclic stress levels for secant modulus	<b>0-10</b> , 0-20, 0-50 % of the estimated shear strength
Normal stress level for shear strength	0, <b>20</b> , 40, 60 % of the estimated shear strength

<sup>A</sup>Boldface values are standard conditions.

the shear tool for tests under combine shear plus tension or shear plus compression.

11.4 Apply shear force to the specimen with a universal testing machine as shown in Fig. 5 or with a hydraulic cylinder as shown in Fig. 6 at the specified rate of crosshead motion.

11.4.1 For single cycle tests, increase the load until failure occurs.

11.4.2 For cyclic tests, increase the load to the specified stress level then unload the specimen at the same rate of crosshead motion as in loading. Repeat this cycle for the specified number of cycles.

11.5 Record the shear load as the ordinate and clamp displacement (slip) as the abscissa simultaneously on linear chart paper during the test.

11.6 Enclose the loading head of the shear tool and the specimen in a suitable controlled-environment chamber for tests conducted at nonambient conditions.

11.7 Weigh the specimens immediately after testing, and determine their moisture contents in accordance with Procedure A of Test Methods D 4442.

## 12. Calculations

### 12.1 Secant Modulus:

12.1.1 The party requesting these tests shall designate the stress levels for which the secant modulus shall be calculated.

12.1.2 Multiply each stress level by the bond area to determine the equivalent load, as follows:

$$\text{Load} = \text{stress} \times \text{bond area} \quad (1)$$

12.1.3 Determine the adhesive slip at the equivalent load levels on the load slip diagram.

12.1.4 Calculate the adhesive strain by dividing adhesive slip by the bondline thickness, as follows:

$$\text{Strain} = \text{slip}/\text{bondline thickness} \quad (2)$$

12.1.5 Calculate the secant modulus at each designated stress level by dividing stress by the corresponding strain, as follows:

$$\text{Secant modulus} = \text{stress}/\text{strain} \quad (3)$$

### 12.2 Shear Strength:

12.2.1 Determine the maximum load the specimen withstood from the load-slip diagram.

12.2.2 Calculate the shear strength by dividing the maximum load by the bond area as follows:

$$\text{Shear strength} = \text{maximum load}/\text{bond area} \quad (4)$$

12.3 Determine the precision of the measurements as follows:

12.3.1 The mean is the sum of the individual measurements (either secant modulus or strength) as follows:

$$\text{Mean} = \bar{x} = \frac{1}{n} \sum_{i=1}^n x_i \quad (5)$$

where:

$n$  = total number of measurements of secant modulus or shear strength, and

$x_i$  = an individual measurement (the  $i$ th value of the  $n$  measurements) of secant modulus or shear strength.

12.3.2 The standard deviation is the square root of the squared sum of the individual values minus the mean squared, times the number of measurements, and this quantity divided by one less than the number of measurements, as follows:

$$\text{Standard deviation} = \sqrt{(\sum x_i^2 - n\bar{x}^2)/(n - 1)} \quad (6)$$

12.3.3 The standard error of the mean is equal to the standard deviation divided by the square root of the number of measurements, as follows:

$$\text{Standard error of the mean} = \text{standard deviation}/\sqrt{n} \quad (7)$$

## 13. Report

13.1 The report shall include the following information for each series of specimens tested:

13.1.1 Adhesive,

13.1.2 Adherends (species and density),

13.1.3 Wood moisture content at bonding,

13.1.4 Method of bondline thickness control,

13.1.5 Cure conditions,

13.1.6 Specimen dimensions,

13.1.7 Average bondline thickness,

13.1.8 Aging treatment, if any,

13.1.9 Rate of crosshead motion during test,

13.1.10 Temperature, humidity, and wood moisture content at test,

13.1.11 Number of cycles and the intermediate stress level prior to determination of the secant modulus or strength,

13.1.12 Normal stress applied during the test,

13.1.13 Mean secant modulus and standard error of the mean and the stress level where determined,

13.1.14 Mean shear strength and standard error of the mean, and

13.1.15 Appearance of the failed surface.

## 14. Precision and Bias

14.1 No precision or bias exists for this test method, as the necessary resources for round-robin testing have not been forthcoming.

## 15. Keywords

15.1 modified rail; shear; shear modulus; shear strength; strain

*ASTM International takes no position respecting the validity of any patent rights asserted in connection with any item mentioned in this standard. Users of this standard are expressly advised that determination of the validity of any such patent rights, and the risk of infringement of such rights, are entirely their own responsibility.*

*This standard is subject to revision at any time by the responsible technical committee and must be reviewed every five years and if not revised, either reapproved or withdrawn. Your comments are invited either for revision of this standard or for additional standards and should be addressed to ASTM International Headquarters. Your comments will receive careful consideration at a meeting of the responsible technical committee, which you may attend. If you feel that your comments have not received a fair hearing you should make your views known to the ASTM Committee on Standards, at the address shown below.*

*This standard is copyrighted by ASTM International, 100 Barr Harbor Drive, PO Box C700, West Conshohocken, PA 19428-2959, United States. Individual reprints (single or multiple copies) of this standard may be obtained by contacting ASTM at the above address or at 610-832-9585 (phone), 610-832-9555 (fax), or service@astm.org (e-mail); or through the ASTM website (www.astm.org).*