

Foundation Design

Foundations

A foundation is defined as the engineered interface between the earth and the structure it supports that transmits the loads to the soil or rock. The design differs from structural design in that the choices in material and framing system are not available, and quality of materials cannot be assured. Foundation design is dependent on geology and climate of the site.

Soil Mechanics

Soil is another building material and the properties, just like the ones necessary for steel and concrete and wood, must be known before designing. In addition, soil has other properties due to massing of the material, how soil particles pack or slide against each other, and how water affects the behavior. The important properties are

- specific weight (density)
- allowable soil pressure
- factored net soil pressure – allowable soil pressure less surcharge with a factor of safety
- shear resistance
- backfill pressure
- cohesion & friction of soil
- effect of water
- settlement
- rock fracture behavior

Structural Strength and Serviceability

There are significant serviceability considerations with soil. Soils can settle considerably under foundation loads, which can lead to redistribution of moments in continuous slabs or beams, increases in stresses and cracking. Excessive loads can cause the soil to fail in bearing and in shear. The presence of water can cause soils to swell or shrink and freeze and thaw, which causes heaving. Fissures or fault lines can cause seismic instabilities.

A geotechnical engineer or engineering service can use tests on soil bearings from the site to determine the ultimate bearing capacity, q_u . Allowable stress design is utilized for soils because of the variability do determine the allowable bearing capacity, $q_a = q_u / (\text{safety factor})$.

Values of q_a range from 3000 – 4000 psi for most soils, while clay type soils have lower capacities and sandy soils to rock have much higher capacities.

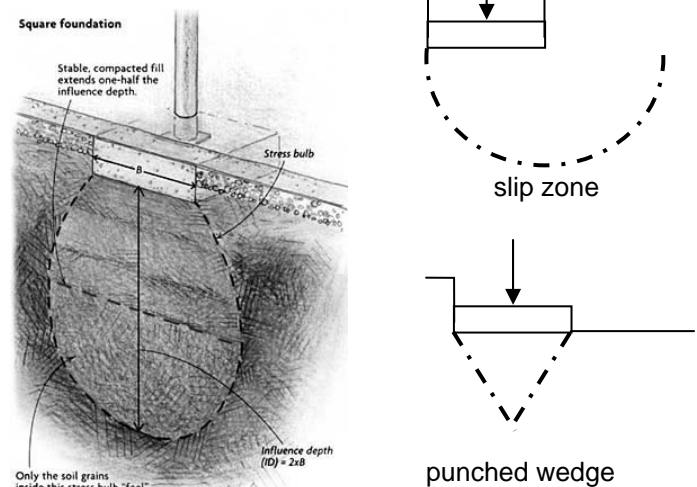

Soil acts somewhat like water, in that it exerts a lateral pressure because of the weight of the material above it, but the relationship is not linear. Soil can have an active pressure from soil behind a retaining wall and a passive pressure from soil in front of the footing. Active pressure is typically greater than passive pressure.

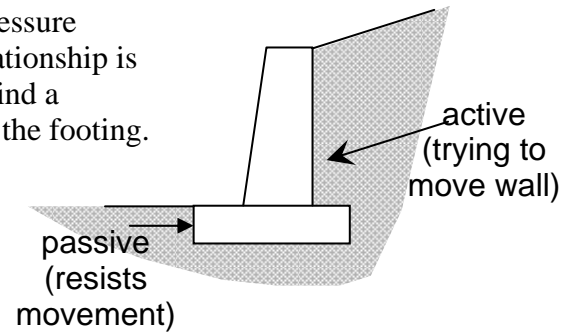

Foundation Materials

Typical foundation materials include:

- plain concrete
- reinforced concrete
- steel
- wood
- composites, ie. steel tubing filled with concrete

Table 7-1 Average Bearing Capacities of Various Foundation Beds

| Soil | Bearing Capacity, q_a (ksf) |
|---------------------------------|----------------------------------|
| Alluvial soil | ≤ 1 |
| Soft clay | 2 |
| Firm clay | 4 |
| Wet sand | 4 |
| Sand and clay mixed | 4 |
| Fine dry sand (compact) | 6 |
| Hard clay | 8 |
| Coarse dry sand (compact) | 8 |
| Sand and gravel mixed (compact) | 10 |
| Gravel (compact) | 12 |
| Soft rock | 16 |
| Hard pan or hard shale | 20 |
| Medium rock | 30 |
| Hard rock | 80 |

Foundation Design

Generalized Design Steps

Design of foundations with variable conditions and variable types of foundation structures will be different, but there are steps that are typical to every design, including:

1. Calculate loads from structure, surcharge, active & passive pressures, etc.
2. Characterize soil – hire a firm to conduct soil tests and produce a report that includes soil material properties
3. Determine footing location and depth – shallow footings are less expensive, but the variability of the soil from the geotechnical report will drive choices
4. Evaluate soil bearing capacity – the factor of safety is considered here
5. Determine footing size – these calculations are based on working loads and the allowable soil pressure
6. Calculate contact pressure and check stability
7. Estimate settlements
8. Design the footing structure – design for the material based on applicable structural design codes which may use allowable stress design, LRFD or limit state design (concrete).

Shallow Foundation Types

Considered simple and cost effective because little soil is removed or disturbed.

Spread footing – A single column bears on a square or rectangular pad to distribute the load over a bigger area.

Wall footing – A continuous wall bears on a wide pad to distribute the load.

Eccentric footing – A spread or wall footing that also must resist a moment in addition to the axial column load.

Combined footing – Multiple columns (typically two) bear on a rectangular or trapezoidal shaped footing.

Unsymmetrical footing – A footing with a shape that does not evenly distribute bearing pressure from column loads and moments. It typically involves a hole or a non-rectangular shape influenced by a boundary or property line.

Strap footing – A combined footing consisting of two spread footings with a beam or strap connecting the slabs. The purpose of this is to limit differential settlements.

Mat foundation – A slab that supports multiple columns. The mat can be stiffened with a grid or grade beams. It is typically used when the soil capacity is very low.

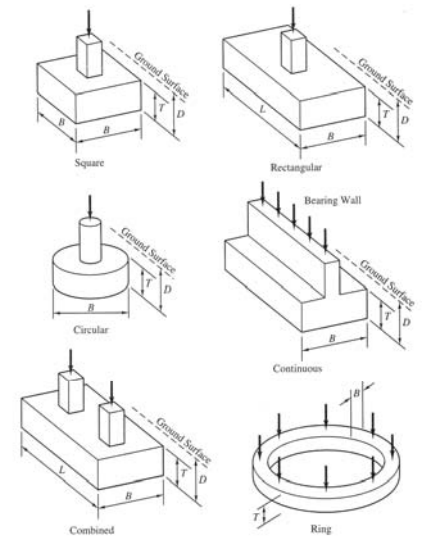

Figure 5.1 Spread footing shapes and dimensions.

Deep Foundation Types

Considerable material and excavation is required, increasing cost and effort.

Retaining Walls – A wall that retains soil or other materials, and must resist sliding and overturning. Can have counterforts, buttresses or keys.

Basement Walls – A wall that encloses a basement space, typically next to a floor slab, and that may be restrained at the top by a floor slab.

Piles – Next choice when spread footings or mats won't work, piles are used to distribute loads by end bearing to strong soil or friction to low strength soils. Can be used to resist uplift, a moment causing overturning, or to compact soils. Also useful when used in combination to control settlements of mats or slabs.

Drilled Piers – Soil is removed to the shape of the pier and concrete is added.

Caissons – Water and possibly wet soil is held back or excavated while the footing is constructed or dropped into place.

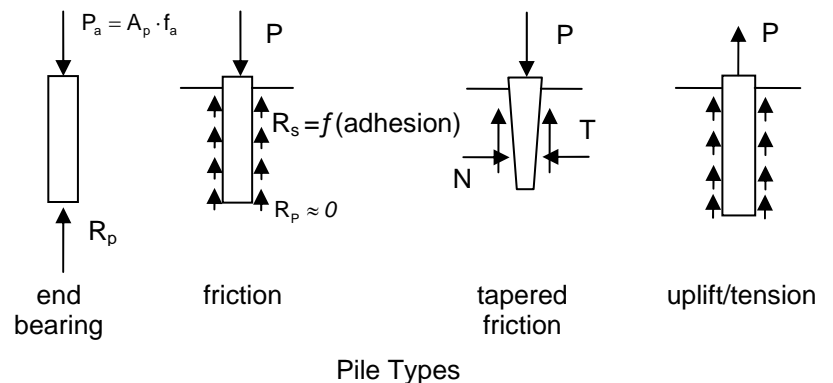

Loads and Stresses

Bearing loads must be distributed to the soil materials, but because of their variability and the stiffness of the footing pad, the resulting stress, or soil pressure, is not necessarily uniform. But we assume it is for design because dealing with the complexity isn't worth the time or effort.

The increase in weight when replacing soil with concrete is called the overburden. Overburden may also be the result of adding additional soil to the top of the excavation for a retaining wall. It is extra *uniformly distributed load* that is considered by reducing the allowable soil pressure (instead of increasing the loads), resulting in a net allowable soil pressure, q_{net} :

$$q_{net} = q_{allowable} - h_f (\gamma_c - \gamma_s)$$

In order to design the footing size, the actual stress P/A must be less than or equal to the allowable pressure:

$$\frac{P}{A} \leq q_{net}$$

Design Stresses

The result of a uniform pressure on the underside of a footing is identical to a distributed load on a slab over a column when looked at *upside down*. The footing slab must resist bending, one-way shear and two-way shear (punching).

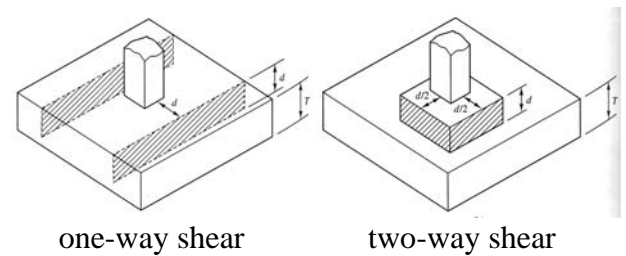

Stresses with Eccentric Loading

Combined axial and bending stresses increase the pressure on one edge or corner of a footing. We assume again a linear distribution based on a constant relationship to settling. If the pressure combination is in tension, this effectively means the contact is gone between soil and footing and the pressure is really zero. To avoid zero pressure, the eccentricity must stay within the kern. The maximum pressure must not exceed the net allowable soil pressure.

If the contact is gone, the maximum pressure can be determined knowing that the volume of the *pressure wedge* has to equal the column load, and the centroid of the *pressure wedge* coincides with the effective eccentricity.

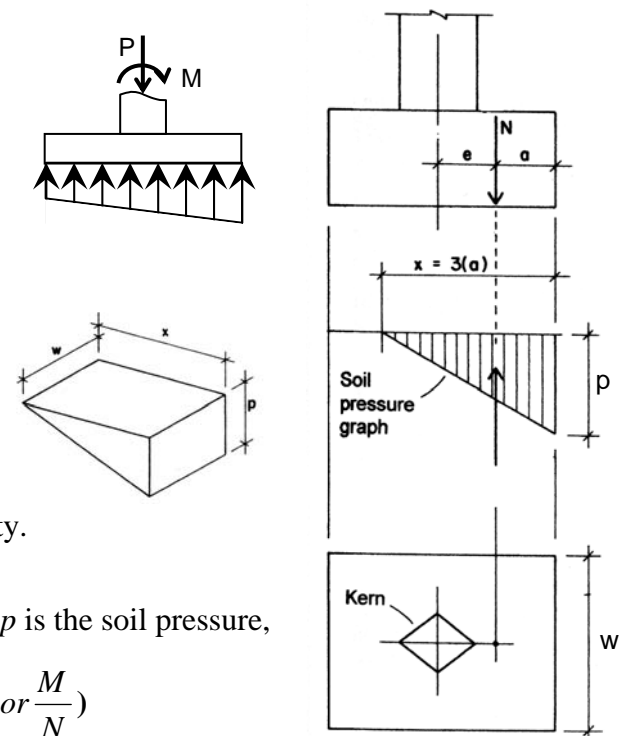

Wedge volume is $V = \frac{wp_x}{2}$ where w is the width, p is the soil pressure,

and x is the wedge length, so $p = \frac{2P}{wx}$ or $\frac{2N}{wx}$ (and $e = \frac{M}{P}$ or $\frac{M}{N}$)

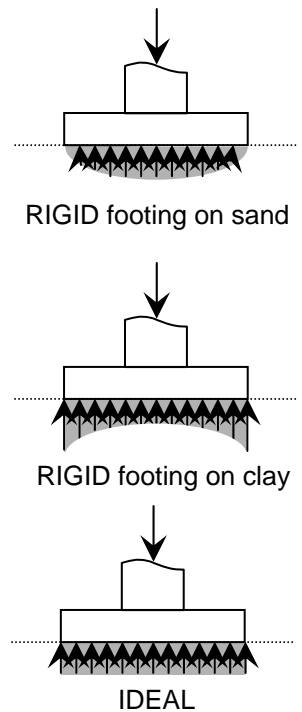

Overturning is considered in design such that the resisting moment from the soil pressure (equivalent force at load centroid) is greater than the overturning moment, M , by a factor of safety of at least 1.5

$$SF = \frac{M_{resist}}{M_{overturning}} \geq 1.5$$

where

M_{resist} = average resultant soil pressure x width x location of load centroid with respect to column centroid

$M_{overturning} = P \times e$

Combined Footings

The design of combined footing requires that the centroid of the area be as close as possible to the resultant of the two column loads for uniform pressure and settling.

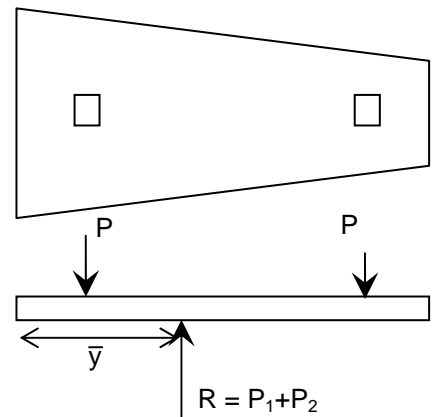

Retaining Walls

The design of retaining walls must consider overturning, settlement, sliding and bearing pressure. The water in the retained soil can significantly affect the loading and the active pressure of the soil. The lateral force acting at a height of $H/3$ is determined from the active pressure, p_A , (in force/cubic area) as:

$$H_A = \frac{p_A H^2}{2}$$

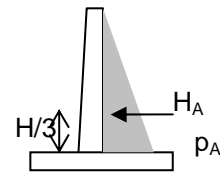

Overturning is considered the same as for eccentric footings:

$$SF = \frac{M_{resist}}{M_{overturning}} \geq 1.5 - 2$$

where

M_{resist} = summation of moments about "o" to resist rotation, typically including the moment due to the weight of the stem and base and the moment due to the passive pressure.

$M_{overturning}$ = moment due to the active pressure about "o".

Sliding must also be avoided:

$$SF = \frac{F_{horizontal-resist}}{F_{sliding}} \geq 1.25 - 2$$

where:

$F_{horizontal-resist}$ = summation of forces to resist sliding, typically including the force from the passive pressure and friction ($F = \mu \cdot N$ where μ is a constant for the materials in contact and N is the normal force to the ground acting down and shown as R).

$F_{sliding}$ = sliding force as a result of active pressure.

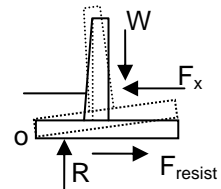

For sizing, some rules of thumbs are:

- footing size, B
- reinforced concrete, $B \approx 2/5 - 2/3$ wall height (H)
- footing thickness, $h_f \approx 1/12 - 1/8$ footing size (B)
- base of stem, $b \approx 1/10 - 1/12$ wall height ($H+h_f$)
- top of stem, $t \geq 12$ inches

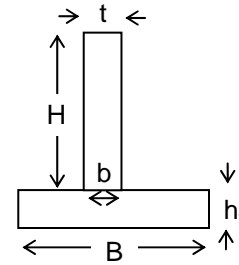

Example 1 (page 486) #2

Example 2. Design a square column footing for the following data:

Column load = 200 kips [890 kN] dead load and 300 kips [1334 kN] live load

Column size = 15 in. [380 mm] square

Maximum allowable soil pressure = 4000 psf [200 kPa]

Concrete design strength = 3000 psi [21 MPa]

Yield stress of steel reinforcement = 40 ksi [280 MPa]

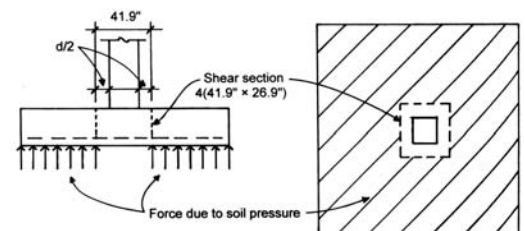
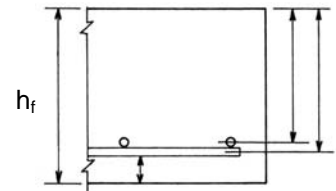
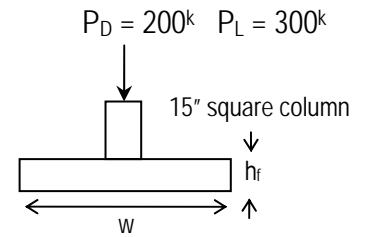

(b) For punching shear

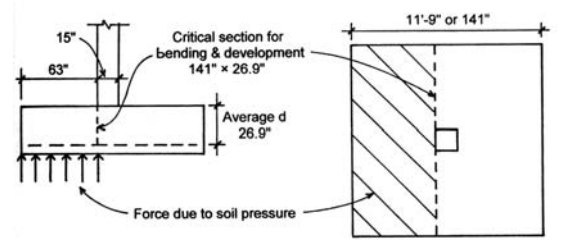
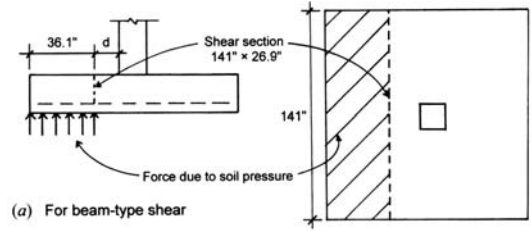

Example 2

Determine the depth required for the group of 4 friction piles having 12” diameters if the column load is 100 kips and the frictional resistance is 400 lbs/ft².

SOLUTION:

The downward load is resisted by a friction force. Friction is determined by multiplying the friction resistance (a stress) by the area: $F = fA_{SKIN}$

The area of n cylinders is: $A_{SKIN} = n(2\pi \frac{d}{2} L)$

Our solution is to set $P \leq F$ and solve for length:

$$100k \leq 400 \frac{lb}{ft^2} (4^{piles}) (\pi) (\frac{12in}{2}) L \cdot (\frac{1ft}{12in}) \cdot (\frac{1k}{1000lb})$$

$$L \geq 19.9 \frac{ft}{pile}$$

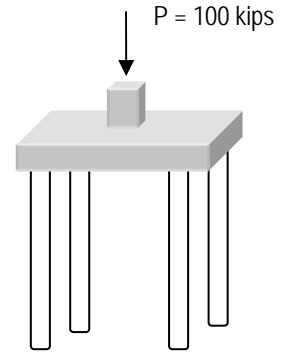

Example 3

Determine the depth required for the friction & bearing pile having a 36” diameter if the column load is 300 kips, the frictional resistance is 600 lbs/ft² and the end bearing pressure allowed is 8000 psf.

SOLUTION:

The downward load is resisted by a friction force and a bearing force, which can be determined from multiplying the bearing pressure by the area in contact: $F = fA_{SKIN} + qA_{TIP}$

The area of a circle is: $A_{TIP} = \pi \frac{d^2}{4}$

Our solution is to set $P \leq F$ and solve for length:

$$300k \leq 600 \frac{lb}{ft^2} \pi (\frac{36in}{2}) L \cdot (\frac{1ft}{12in}) \cdot (\frac{1k}{1000lb}) + 8000 \frac{lb}{ft^2} \pi \frac{(36in)^2}{4} \cdot (\frac{1ft}{12in})^2 \cdot (\frac{1k}{1000lb})$$

$$L \geq 26 / 1ft$$

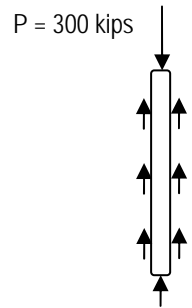

Example 4

Determine the factor of safety for overturning and sliding on the 15’ retaining wall, 16” wide stem, 10’ base, 16” high base, when the equivalent fluid pressure is 30 pcf, the weight of the stem of the footing is 4 kips, the weight of the pad is 5 kips, the passive pressure is ignored for this design, and the friction coefficient for sliding is 0.58. The center of the stem is located 3’ from the toe.

