

Main Wind Force Resisting System – Method 2		$h \leq 60$ ft.
Figure 28.6-1	Design Wind Pressures	Walls & Roofs
Enclosed Buildings		

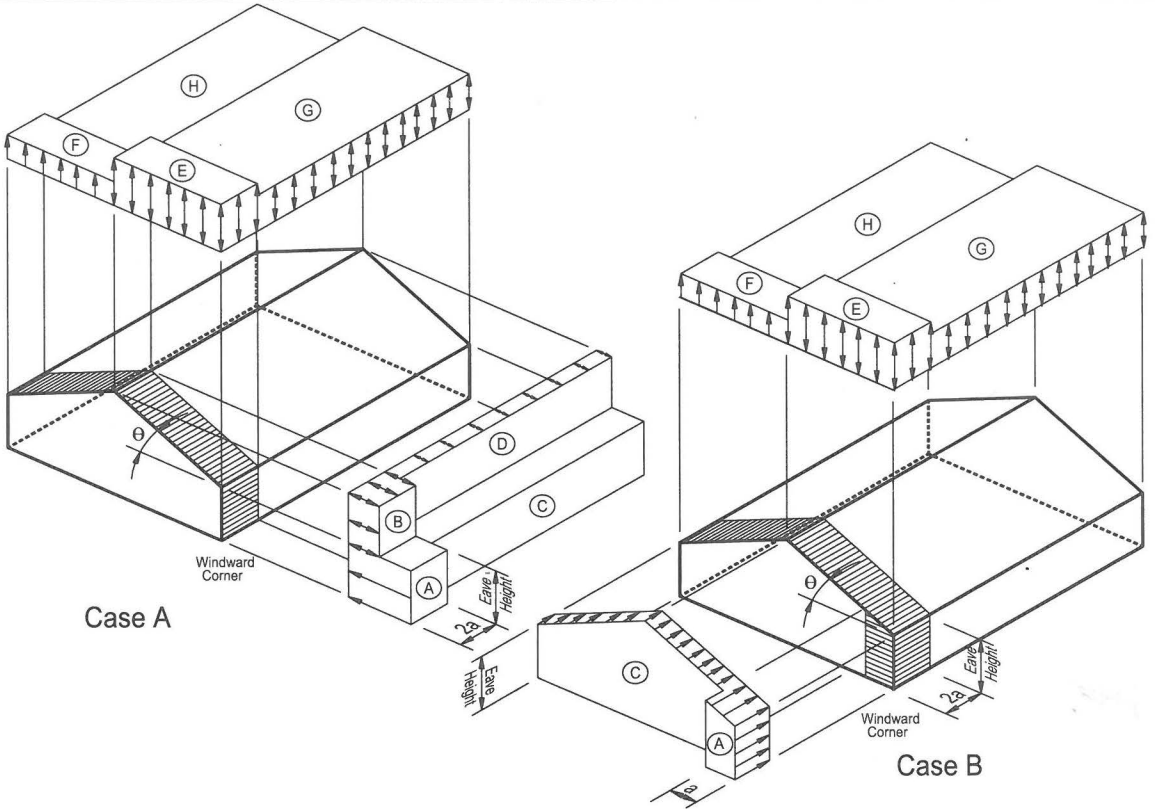

Notes:

1. Pressures shown are applied to the horizontal and vertical projections, for exposure B, at $h=30$ ft (9.1m). Adjust to other exposures and heights with adjustment factor λ .
2. The load patterns shown shall be applied to each corner of the building in turn as the reference corner. (See Figure 28.4-1)
3. For Case B use $\theta = 0^\circ$.
4. Load cases 1 and 2 must be checked for $25^\circ < \theta \leq 45^\circ$. Load case 2 at 25° is provided only for interpolation between 25° and 30° .
5. Plus and minus signs signify pressures acting toward and away from the projected surfaces, respectively.
6. For roof slopes other than those shown, linear interpolation is permitted.
7. The total horizontal load shall not be less than that determined by assuming $p_s = 0$ in zones B & D.
8. Where zone E or G falls on a roof overhang on the windward side of the building, use E_{OH} and G_{OH} for the pressure on the horizontal projection of the overhang. Overhangs on the leeward and side edges shall have the basic zone pressure applied.
9. Notation:
 - a : 10 percent of least horizontal dimension or $0.4h$, whichever is smaller, but not less than either 4% of least horizontal dimension or 3 ft (0.9 m).
 - h : Mean roof height, in feet (meters), except that eave height shall be used for roof angles $<10^\circ$.
 - θ : Angle of plane of roof from horizontal, in degrees.