



AISI S230-15



AISI STANDARD

Standard for Cold-Formed Steel Framing – Prescriptive Method for One- and Two-Family Dwellings

2015 Edition



AISI S230-15



AISI STANDARD

Standard for Cold-Formed Steel Framing — Prescriptive Method for One- and Two-Family Dwellings

2015 Edition

Revision of:
AISI S230-07 With Supplements 2 and 3
(Reaffirmed 2012)

DISCLAIMER

The material contained herein has been developed by the American Iron and Steel Institute (AISI) Committee on Framing Standards. The Committee has made a diligent effort to present accurate, reliable, and useful information on cold-formed steel framing design and installation. The Committee acknowledges and is grateful for the contributions of the numerous researchers, engineers, and others who have contributed to the body of knowledge on the subject. Specific references are included in the *Commentary*.

With anticipated improvements in understanding of the behavior of cold-formed steel framing and the continuing development of new technology, this material will become dated. It is anticipated that AISI will publish updates of this material as new information becomes available, but this cannot be guaranteed.

The materials set forth herein are for general purposes only. They are not a substitute for competent professional advice. Application of this information to a specific project should be reviewed by a design professional. Indeed, in many jurisdictions, such review is required by law. Anyone making use of the information set forth herein does so at their own risk and assumes any and all liability arising therefrom.

1st Printing – November 2015

Produced by American Iron and Steel Institute

Copyright American Iron and Steel Institute 2015

PREFACE

The American Iron and Steel Institute Committee on Framing Standards has developed AISI S230-15, the 2015 edition of the *Standard for Cold-Formed Steel Framing – Prescriptive Method for One- and Two-Family Dwellings*, to provide prescriptive requirements for cold-formed steel-framed detached one- and two-family dwellings, townhouses, attached multi-family dwellings, and other attached single-family dwellings. This edition supersedes the previous edition designated as AISI S230-07 with Supplement 2 and Supplement 3 (Reaffirmed 2012).

In 2015, updates were made in order to bring AISI S230 into full compliance with the 2015 edition of the *International Residential Code, ASCE 7-10* including applicable supplements, and the latest referenced documents. Provisions were added for larger openings in floors, ceilings and roofs. Additionally, the tables were streamlined to reduce complexity and volume of the provisions, as follows:

- Eliminated provisions for 85 mph Wind Exposure B wind speeds (now 110 mph in ASCE 7-10).
- Tabulated solutions for just one material grade per thickness.
- Eliminated the multi-span floor joist and ceiling joist tables.
- Eliminated tables for ceiling joists with bearing stiffeners.

The Committee acknowledges and is grateful for the contributions of the numerous engineers, researchers, producers and others who have contributed to the body of knowledge on the subjects.

This Page is Intentionally Left Blank.

AISI COMMITTEE ON FRAMING STANDARDS

Richard Haws, <i>Chairman</i>	Nucor Corporation
Steve Fox, <i>Vice Chairman</i>	Canadian Sheet Steel Building Institute
Helen Chen, <i>Secretary</i>	American Iron and Steel Institute
Don Allen	Super Stud Building Products
Bill Babich	Alpine TrusSteel
Brad Cameron	Cameron & Associates Engineering, LLC
Randy Daudet	Simpson Strong-Tie
Jim DesLaurier	Certified Steel Stud Association
Scott Douglas	National Council of Structural Engineers Associations
Nader Elhajj	FrameCAD Solutions
Pat Ford	Steel Framing Industry Association
Jeff Klaiman	ADTEK Engineers
Roger LaBoube	Wei-Wen Yu Center for Cold-Formed Steel Structures
Rob Madsen	Supreme Steel Framing System Association
John Matsen	Matsen Ford Design Associates
Cris Moen	Virginia Polytechnic Institute and State University
Kenneth Pagano	Scosta Corporation
Mike Pellock	Aegis Metal Framing
Nabil Rahman	The Steel Network, Inc.
Greg Ralph	ClarkDietrich Building Systems
Ben Schafer	Johns Hopkins University
Fernando Sesma	California Expanded Metal Products
Sutton Stephens	Pacific Northwest Engineering, Inc.
Steven Walker	Light Gauge Steel Engineering Group, Inc.
Robert Wessel	Gypsum Association
Lei Xu	University of Waterloo
Cheng Yu	University of North Texas
Rahim Zadeh	Steel Stud Manufacturers Association
Ron Ziemian	Structural Stability Research Council

PRESCRIPTIVE METHOD SUBCOMMITTEE

Sutton Stephens, <i>Chairman</i>	Pacific Northwest Engineering, Inc.
Helen Chen, <i>Secretary</i>	American Iron and Steel Institute
Randy Daudet	Simpson Strong-Tie
Jim DesLaurier	Certified Steel Stud Association
Nader Elhajj	FrameCAD Solutions
Steve Fox	Canadian Sheet Steel Building Institute
Perry Green	Bechtel Power Corporation
Rick Haws	Nucor Corporation
Stephen Linch	Telling Industries
John Matsen	Matsen Ford Design Associates
Greg Ralph	ClarkDietrich Building Systems
Fernando Sesma	California Expanded Metal Products
Lei Xu	University of Waterloo
Rahim Zadeh	Steel Stud Manufacturers Association

TABLE OF CONTENTS

STANDARD FOR COLD-FORMED STEEL FRAMING— PRESCRIPTIVE METHOD FOR ONE- AND TWO-FAMILY DWELLINGS

Disclaimer	ii
Preface	iii
AISI Committee on Framing Standards.....	iv
Prescriptive Method Subcommittee	vi
List of Figures	x
List of Tables.....	xii
STANDARD FOR COLD-FORMED STEEL FRAMING — PRESCRIPTIVE METHOD FOR ONE- AND TWO-FAMILY DWELLINGS	1
A. GENERAL	1
A1 Scope.....	1
A1.1 Limits of Applicability	1
A1.2 Limitations in High Seismic Areas and High Wind Areas.....	1
A1.2.1 Irregular Buildings in High Seismic Areas and High Wind Areas.....	2
A2 Definitions	2
A3 Referenced Documents	4
A4 Limitations of Framing Members.....	5
A4.1 General.....	5
A4.2 Sheathing Span Capacity	5
A4.2.1 Floor Framing.....	5
A4.2.2 Wall Framing.....	5
A4.2.3 Roof and Ceiling Framing.....	5
A4.3 Physical Dimensions	5
A4.4 Material Properties.....	5
A4.4.1 Material Properties in High Wind Areas and High Seismic Areas	5
A4.5 Web Holes.....	5
A4.6 Hole Reinforcing.....	5
A4.7 Hole Patching.....	6
B. CONNECTIONS.....	13
B1 Fastening Requirements	13
B2 Bearing Stiffeners.....	13
B3 Clip Angles	13
B4 Anchor Bolts.....	14
C. FOUNDATION	17
C1 General.....	17
D. FLOOR FRAMING.....	18
D1 Floor Construction.....	18
D2 Floor to Foundation or Structural Wall Connection.....	18
D3 Minimum Floor Joist Sizes	18
D3.1 Floor Cantilevers	18
D4 Bearing Stiffeners.....	18
D5 Joist Bracing and Blocking.....	18
D5.1 Joist Top Flange Bracing.....	18
D5.2 Joist Bottom Flange Bracing/Blocking	19
D5.3 Blocking at Interior Bearing Supports	19

D5.4 Blocking at Cantilevers	19
D6 Splicing.....	19
D7 Framing of Floor Openings.....	19
D8 Floor Trusses	20
D9 Diaphragms	20
D9.1 Floor Diaphragms in High Seismic Areas and High Wind Areas.....	20
E. WALL FRAMING.....	36
E1 Wall Construction.....	36
E2 Wall to Foundation or Floor Connection	36
E2.1 Uplift Connection In High Wind Areas - Wall Assembly to Foundation or Floor Assembly	36
E3 Minimum Stud Sizes	36
E4 Stud Bracing	37
E5 Splicing.....	37
E6 Corner Framing.....	37
E7 Headers	37
E7.1 Box-Beam Headers	37
E7.2 Back-to-Back Headers	38
E7.3 L-Headers	38
E7.3.1 Double L-Headers.....	38
E7.3.2 Single L-Headers.....	39
E7.3.3 Inverted L-Header Assemblies	39
E7.4 Jack and King Studs	39
E7.5 Head and Sill Track.....	39
E8 Wall Bracing	39
E8.1 Strap Bracing (X-Brace).....	39
E8.2 Structural Sheathing.....	40
E8.2.1 Sheathing Materials	40
E8.2.2 Determination of Minimum Length of Full-Height Sheathing	40
E8.2.3 Structural Sheathing Fastening.....	40
E8.2.4 Uplift Connection Requirements	41
E9 Exterior Wall Covering.....	41
E10 Reserved.....	41
E11 Braced Walls in High Wind Areas and High Seismic Areas	41
E11.1 General.....	41
E11.2 Braced Wall Lines.....	41
E11.3 Type I (Solid Sheathed) Braced Wall Panels.....	42
E11.4 Type II (Perforated) Braced Wall Lines.....	42
E11.5 Braced Wall Anchorage and Chord Stud Requirements	43
E11.6 Attachment of Braced Walls to Foundations and Floor and Roof Diaphragms.....	43
E12 Braced Wall Design in High Seismic Areas	43
E12.1 Length of Type I Braced Wall Panels.....	43
E12.2 Braced Wall Anchorage and Chord Stud Requirements	44
E12.3 Wall Top Track	44
E13 Braced Wall Design in High Wind Areas	44
E13.1 General.....	44
E13.2 Length of Braced Walls.....	44
E13.3 Connections of Walls in High Wind Areas.....	45
E13.3.1 General	45

E13.3.2 Uplift Connection - Wall Assembly to Wall Assembly	45
E13.3.3 Header Uplift Connections	45
E13.3.3.1 Single Story or Top of a Two- or Three-Story Building	45
E13.3.3.2 Middle and Bottom Stories of a Two- or Three-Story Building	46
E13.3.4 Wall Bottom Track to Foundation	46
E13.4 Braced Wall Anchorage and Chord Stud Requirements	46
F. ROOF FRAMING.....	155
F1 Roof Construction.....	155
F2 Ceiling Joists.....	155
F2.1 Minimum Ceiling Joist Size	155
F2.2 Ceiling Joist Bearing Stiffeners	155
F2.3 Ceiling Joist Bottom Flange Bracing	155
F2.4 Ceiling Joist Top Flange Bracing	155
F2.5 Ceiling Joist Splicing	156
F3 Roof Rafters	156
F3.1 Minimum Roof Rafter Sizes	156
F3.1.1 Eave Overhang	156
F3.1.2 Rake Overhang	156
F3.2 Roof Rafter Support Brace.....	156
F3.3 Roof Rafter Splice	157
F3.4 Roof Rafter to Ceiling Joist and Ridge Member Connection.....	157
F3.5 Roof Rafter Bottom Flange Bracing.....	157
F4 Hip Framing	157
F4.1 Jack Rafters	158
F4.2 Hip Members	158
F4.3 Hip Support Columns.....	158
F4.4 Hip Framing Connections	158
F5 Framing of Openings in Roofs and Ceilings.....	158
F6 Roof Trusses	159
F7 Ceiling and Roof Diaphragms	159
F7.1 Roof Diaphragms in High Seismic Areas.....	159
F7.2 Roof Diaphragms in High Wind Areas.....	160
F8 Roof Framing Connections in High Wind Areas	160
F8.1 General.....	160
F8.2 Uplift Connection - Roof Rafter or Truss to Wall	160
F8.3 Ridge Strap Connection.....	160

LIST OF FIGURES

Figure A1-1 Building Configuration	7
Figure A1-2 Building Configuration Limitations	8
Figure A1-3 Irregular Buildings.....	8
Figure A4-1 Web Hole Limitations.....	9
Figure A4-2 Web Hole Limitation Adjacent to Bearing.....	9
Figure A4-3 Stud Web Hole Patch.....	10
Figure A4-4 Joist Web Hole Patch	10
Figure B2-1 Bearing Stiffener (Web Stiffener)	14
Figure D2-1 Floor to Exterior Structural Wall Connection	21
Figure D2-2 Floor to Wood Sill Connection	21
Figure D2-3 Floor to Foundation Connection	22
Figure D2-4 Cantilevered Floor to Foundation Connection	23
Figure D2-5 Cantilevered Floor to Wood Sill Connection	24
Figure D2-6 Cantilevered Floor to Exterior Structural Wall Connection.....	24
Figure D2-7 Continuous Span Joist Supported on an Interior Structural Wall.....	25
Figure D2-8 Lapped Joist Supported on Interior Structural Wall.....	26
Figure D2-9 Bearing Stiffeners for End Joist	26
Figure D4-1 Bearing Stiffeners Under Jamb Studs	27
Figure D5-1 Joist Blocking (Solid).....	27
Figure D5-2 Joist Blocking (Strap)	28
Figure D6-1 Track Splice	28
Figure D7-1 Six-Foot Floor Opening	29
Figure D7-2 Twelve-Foot Floor Opening (Eight-Foot and Ten-Foot Similar)	30
Figure D7-3 Floor Header to Trimmer Connection – Six-Foot Opening.....	30
Figure D7-4 Floor Header to Trimmer Connection – Twelve-Foot Opening (Eight-Foot and Ten-Foot Openings Similar).....	31
Figure E2-1 Wall to Foundation Connection.....	48
Figure E2-2 Alternate Wall to Foundation Connection	48
Figure E2-3 Wall to Wood Sill Connection.....	49
Figure E2-4 Wall to Floor Connection.....	49
Figure E2-5 Wind Uplift Connector	50
Figure E4-1 Stud Bracing With Sheathing Material Only	50
Figure E4-2 Stud Bracing With Strapping Only	51
Figure E4-3 Stud Bracing With Strapping and Sheathing Material	51
Figure E5-1 Top Track Splice.....	52
Figure E6-1 Corner Framing Detail	52
Figure E7-1 Box-Beam Header Detail.....	53
Figure E7-2 Back-to-Back Header Detail.....	53
Figure E7-3 Box-Beam Header in Gable Endwall.....	54
Figure E7-4 Back-to-Back Header in Gable Endwall.....	54
Figure E7-5 Double L-Header	55
Figure E7-6 Single L-Header	55
Figure E7-7 Inverted Single or Double L-Header Assembly (Single L-Header Shown).....	56
Figure E8-1 Structural Sheathing Fastening Pattern	57
Figure E8-2 Corner Stud Hold-Down Detail.....	57
Figure E11-1 Type I and Type II Braced Wall Lines.....	58

Figure E11-2 Corner Stud Hold-Down	59
Figure E11-3 Supplemental Chord Stud at First Floor.....	59
Figure E11-4 Floor to Floor Hold-Down.....	60
Figure E11-5 Gable Wall Roof Sheathing Attachment to Braced Walls	60
Figure E11-6 Strap and Blocking at Roof Eave	61
Figure E11-7 Top Track Splice.....	61
Figure E11-8 Floor Diaphragm Attachment to Braced Walls	62
Figure E11-9 Braced Wall to Foundation Connection.....	63
Figure E11-10 Braced Wall to Foundation Connection With Wood Sill	63
Figure E11-11 Floor to Foundation Connection at Braced Wall.....	64
Figure E11-12 Floor to Foundation Connection at Braced Wall With Wood Sill.....	64
Figure E13-1 Back-to-Back Header Beam Reinforcement for Uplift Strap Connection	65
Figure F2-1 Roof Construction.....	161
Figure F2-2 Heel Joint Connection.....	162
Figure F2-3 Bearing Stiffener at the Heel Joint Connection	162
Figure F2-4 Spliced Ceiling Joists	163
Figure F2-5 Ceiling Joist Top Flange Bracing with C-Shape, Track or Cold-Rolled Channel.....	164
Figure F2-6 Ceiling Joist Top Flange Bracing with Continuous Steel Strap and Blocking.....	164
Figure F3-1 Gable Endwall Overhang Details	165
Figure F3-2 Hip Member or Ridge Member Connection	166
Figure F4-1 Jack Rafter Connection at Eave	166
Figure F4-2 Hip Support Column.....	167
Figure F4-3 Hip Connections at Ridge	167
Figure F4-4 Hip Connections at Ridge and Box Column	168
Figure F4-5 Hip Member Connection at Wall Corner	169
Figure F5-1 Roof or Ceiling Opening	170
Figure F5-2 Header to Trimmer Detail.....	170
Figure F7-1 Ceiling Diaphragm to Gable Endwall Detail	171
Figure F7-2 Ceiling Diaphragm to Sidewall Detail	171
Figure F7-3 Roof Blocking Detail.....	172

LIST OF TABLES

Table A1-1 Limits of Applicability	11
Table A1-2 Additional Limitations in High Seismic Areas.....	12
Table A1-3 Equivalent Basic Wind Speed Adjustment Between Wind Exposure D Sites and Wind Exposure C Sites	12
Table A4-1 Cold-Formed Steel Member Sizes	12
Table B1-1 Screw Substitution Factor.....	14
Table B2-1 Clip Angle Bearing Stiffeners 20 psf Equivalent Snow Load.....	15
Table B2-2 Clip Angle Bearing Stiffeners 30 psf Equivalent Snow Load.....	15
Table B2-3 Clip Angle Bearing Stiffeners 50 psf Equivalent Snow Load.....	16
Table B2-4 Clip Angle Bearing Stiffeners 70 psf Equivalent Snow Load.....	16
Table D2-1 Floor to Foundation or Structural Wall Connection Requirements.....	32
Table D2-2 Floor Fastening Schedule.....	32
Table D3-1 Floor Joists – Single Spans	33
Table D7-1 Built-Up Header Size for 10-Foot Floor Opening.....	34
Table D7-2 Built-Up Header Size for 10-Foot Floor Opening.....	34
Table D7-4 Built-Up Header Size for 12-Foot Floor Opening.....	35
Table E2-1 Wall to Foundation or Floor Connection Requirements.....	66
Table E2-2 Gable Endwall to Floor Connection Requirements	67
Table E2-3 Gable Endwall Bottom Track to Foundation Connection Requirements	68
Table E2-4 Required Uplift Strength Wall Assembly to Foundation or Floor Assembly	69
Table E2-5 Uplift Strap Connection Requirements Wall Assembly to Foundation or Floor Assembly	70
Table E3-1 Stud Thickness 24-Foot-Wide Building Supporting Roof and Ceiling Only	71
Table E3-2 Stud Thickness 28-Foot-Wide Building Supporting Roof and Ceiling Only	72
Table E3-3 Stud Thickness 32-Foot-Wide Building Supporting Roof and Ceiling Only	73
Table E3-4 Stud Thickness 36-Foot-Wide Building Supporting Roof and Ceiling Only	74
Table E3-5 Stud Thickness 40-Foot-Wide Building Supporting Roof and Ceiling Only	75
Table E3-6 Stud Thickness 24-Foot-Wide Building Supporting One Floor, Roof & Ceiling	76
Table E3-7 Stud Thickness 28-Foot-Wide Building Supporting One Floor, Roof & Ceiling	77
Table E3-8 Stud Thickness 32-Foot-Wide Building Supporting One Floor, Roof & Ceiling	78
Table E3-9 Stud Thickness 36-Foot-Wide Building Supporting One Floor, Roof & Ceiling	79
Table E3-10 Stud Thickness 40-Foot-Wide Building Supporting One Floor, Roof & Ceiling	80
Table E3-11 Stud Thickness 24-Foot-Wide Building Supporting Two Floors, Roof & Ceiling... ..	81
Table E3-12 Stud Thickness 28-Foot-Wide Building Supporting Two Floors, Roof & Ceiling... ..	82
Table E3-13 Stud Thickness 32-Foot-Wide Building Supporting Two Floors, Roof & Ceiling... ..	83
Table E3-14 Stud Thickness 36-Foot-Wide Building Supporting Two Floors, Roof & Ceiling... ..	84
Table E3-15 Stud Thickness 40-Foot-Wide Building Supporting Two Floors, Roof & Ceiling... ..	85
Table E3-16 Stud Thickness All Building Widths Gable Endwalls 8, 9 or 10 Feet in Height	86
Table E3-17 Stud Thickness All Building Widths Gable Endwalls Over 10 Feet in Height.....	87
Table E3-18 Wall Fastening Schedule.....	88
Table E3-19 Minimum Wall Sheathing Attachment for Wind Loads	88
Table E7-1 Box-Beam Header Spans, Headers Supporting Roof and Ceiling Only	89
Table E7-2 Box-Beam Header Spans, Headers Supporting Roof and Ceiling Only	90
Table E7-3 Box-Beam Header Spans, Headers Supporting One Floor, Roof and Ceiling	91
Table E7-4 Box-Beam Header Spans, Headers Supporting One Floor, Roof and Ceiling	92
Table E7-5 Box-Beam Header Spans, Headers Supporting Two Floors, Roof and Ceiling	93

Table E7-6 Box-Beam Header Spans, Headers Supporting Two Floors, Roof and Ceiling.....	94
Table E7-7 Back-to-Back Header Spans, Headers Supporting Roof and Ceiling Only.....	95
Table E7-8 Back-to-Back Header Spans, Headers Supporting Roof and Ceiling Only.....	96
Table E7-9 Back-to-Back Header Spans, Headers Supporting One Floor, Roof and Ceiling.....	97
Table E7-10 Back-to-Back Header Spans, Headers Supporting One Floor, Roof and Ceiling.....	98
Table E7-11 Back-to-Back Header Spans, Headers Supporting Two Floors, Roof and Ceiling....	99
Table E7-12 Back-to-Back Header Spans, Headers Supporting Two Floors, Roof and Ceiling..	100
Table E7-13 Number of Screws Required for Header to King Stud Connection.....	101
Table E7-14 Double L-Header Spans – Gravity Loading Headers Supporting Roof and Ceiling Only.....	102
Table E7-15 Double L-Header Spans – Gravity Loading Headers Supporting Roof and Ceiling Only.....	102
Table E7-16 Double L-Header Spans – Gravity Loading Headers Supporting One Floor, Roof and Ceiling.....	103
Table E7-17 Double L-Header Spans – Gravity Loading Headers Supporting One Floor, Roof and Ceiling.....	104
Table E7-18 Double L-Header Spans – Gravity Loading Headers Supporting Two Floors, Roof and Ceiling.....	105
Table E7-19 Double L-Header Spans – Gravity Loading Headers Supporting Two Floors, Roof and Ceiling.....	105
Table E7-20 Double L-Header Spans – Uplift Loading Headers Supporting Roof and Ceiling Only 24-Foot-Wide Building.....	106
Table E7-21 Double L-Header Spans – Uplift Loading Headers Supporting Roof and Ceiling Only 28-Foot-Wide Building.....	106
Table E7-22 Double L-Header Spans – Uplift Loading Headers Supporting Roof and Ceiling Only 32-Foot-Wide Building.....	107
Table E7-23 Double L-Header Spans – Uplift Loading Headers Supporting Roof and Ceiling Only 36-Foot-Wide Building.....	107
Table E7-24 Double L-Header Spans – Uplift Loading Headers Supporting Roof and Ceiling Only 40-Foot-Wide Building.....	108
Table E7-25 Double L-Header Spans – Uplift Loading Headers Supporting One Floor, Roof and Ceiling 24-Foot-Wide Building.....	108
Table E7-26 Double L-Header Spans – Uplift Loading Headers Supporting One Floor, Roof and Ceiling 28-Foot-Wide Building.....	109
Table E7-27 Double L-Header Spans – Uplift Loading Headers Supporting One Floor, Roof and Ceiling 32-Foot-Wide Building.....	109
Table E7-28 Double L-Header Spans – Uplift Loading Headers Supporting One Floor, Roof and Ceiling 36-Foot-Wide Building.....	110
Table E7-29 Double L-Header Spans – Uplift Loading Headers Supporting One Floor, Roof and Ceiling 40-Foot-Wide Building.....	110
Table E7-30 Double L-Header Spans – Uplift Loading Headers Supporting Two Floors, Roof and Ceiling 24-Foot-Wide Building.....	111
Table E7-31 Double L-Header Spans – Uplift Loading Headers Supporting Two Floors, Roof and Ceiling 28-Foot-Wide Building.....	111
Table E7-32 Double L-Header Spans – Uplift Loading Headers Supporting Two Floors, Roof and Ceiling 32-Foot-Wide Building.....	112
Table E7-33 Double L-Header Spans – Uplift Loading Headers Supporting Two Floors, Roof and Ceiling 36-Foot-Wide Building.....	112

Table E7-34 Double L-Header Spans – Uplift Loading Headers Supporting Two Floors, Roof and Ceiling 40-Foot-Wide Building	113
Table E7-35 Single L-Header Spans – Gravity Loading Headers Supporting Roof and Ceiling Only	114
Table E7-36 Single L-Header Spans – Gravity Loading Headers Supporting Roof and Ceiling Only	114
Table E7-37 Single L-Header Spans – Gravity Loading Headers Supporting One Floor, Roof and Ceiling	115
Table E7-38 Single L-Header Spans – Gravity Loading Headers Supporting One Floor, Roof and Ceiling	115
Table E7-39 Single L-Header Spans – Gravity Loading Headers Supporting Two Floors, Roof and Ceiling	116
Table E7-40 Single L-Header Spans – Gravity Loading Headers Supporting Two Floors, Roof and Ceiling	116
Table E7-41 Inverted Double L-Header Assembly Spans – Uplift Loading Headers Supporting Roof and Ceiling Only 24-Foot-Wide Building	117
Table E7-42 Inverted Double L-Header Assembly Spans – Uplift Loading Headers Supporting Roof and Ceiling Only 28-Foot-Wide Building	117
Table E7-43 Inverted Double L-Header Assembly Spans – Uplift Loading Headers Supporting Roof and Ceiling Only 32-Foot-Wide Building	118
Table E7-44 Inverted Double L-Header Assembly Spans – Uplift Loading Headers Supporting Roof and Ceiling Only 36-Foot-Wide Building	118
Table E7-45 Inverted Double L-Header Assembly Spans – Uplift Loading Headers Supporting Roof and Ceiling Only 40-Foot-Wide Building	119
Table E7-46 Inverted Double L-Header Assembly Spans – Uplift Loading Headers Supporting One Floor, Roof and Ceiling 24-Foot-Wide Building	119
Table E7-47 Inverted Double L-Header Assembly Spans – Uplift Loading Headers Supporting One Floor, Roof and Ceiling 28-Foot-Wide Building	120
Table E7-48 Inverted Double L-Header Assembly Spans – Uplift Loading Headers Supporting One Floor, Roof and Ceiling 32-Foot-Wide Building	120
Table E7-49 Inverted Double L-Header Assembly Spans – Uplift Loading Headers Supporting One Floor, Roof and Ceiling 36-Foot-Wide Building	121
Table E7-50 Inverted Double L-Header Assembly Spans – Uplift Loading Headers Supporting One Floor, Roof and Ceiling 40-Foot-Wide Building	121
Table E7-51 Inverted Double L-Header Assembly Spans – Uplift Loading Headers Supporting Two Floors, Roof and Ceiling 24-Foot-Wide Building	122
Table E7-52 Inverted Double L-Header Assembly Spans – Uplift Loading Headers Supporting Two Floors, Roof and Ceiling 28-Foot-Wide Building	122
Table E7-53 Inverted Double L-Header Assembly Spans – Uplift Loading Headers Supporting Two Floors, Roof and Ceiling 32-Foot-Wide Building	123
Table E7-54 Inverted Double L-Header Assembly Spans – Uplift Loading Headers Supporting Two Floors, Roof and Ceiling 36-Foot-Wide Building	123
Table E7-55 Inverted Double L-Header Assembly Spans – Uplift Loading Headers Supporting Two Floors, Roof and Ceiling 40-Foot-Wide Building	124
Table E7-56 Inverted Single L-Header Assembly Spans – Uplift Loading Headers Supporting Roof and Ceiling Only 24-Foot-Wide Building	125
Table E7-57 Inverted Single L-Header Assembly Spans – Uplift Loading Headers Supporting Roof and Ceiling Only 28-Foot-Wide Building	125

Table E7-58 Inverted Single L-Header Assembly Spans - Uplift Loading Headers Supporting Roof and Ceiling Only 32-Foot-Wide Building.....	126
Table E7-59 Inverted Single L-Header Assembly Spans - Uplift Loading Headers Supporting Roof and Ceiling Only 36-Foot-Wide Building.....	126
Table E7-60 Inverted Single L-Header Assembly Spans - Uplift Loading Headers Supporting Roof and Ceiling Only 40-Foot-Wide Building.....	127
Table E7-61 Inverted Single L-Header Assembly Spans - Uplift Loading Headers Supporting One Floor, Roof and Ceiling 24-Foot-Wide Building.....	127
Table E7-62 Inverted Single L-Header Assembly Spans - Uplift Loading Headers Supporting One Floor, Roof and Ceiling 28-Foot-Wide Building.....	128
Table E7-63 Inverted Single L-Header Assembly Spans - Uplift Loading Headers Supporting One Floor, Roof and Ceiling 32-Foot-Wide Building.....	128
Table E7-64 Inverted Single L-Header Assembly Spans - Uplift Loading Headers Supporting One Floor, Roof and Ceiling 36-Foot-Wide Building.....	129
Table E7-65 Inverted Single L-Header Assembly Spans - Uplift Loading Headers Supporting One Floor, Roof and Ceiling 40-Foot-Wide Building.....	129
Table E7-66 Inverted Single L-Header Assembly Spans - Uplift Loading Headers Supporting Two Floors, Roof and Ceiling 24-Foot-Wide Building.....	130
Table E7-67 Inverted Single L-Header Assembly Spans - Uplift Loading Headers Supporting Two Floors, Roof and Ceiling 28-Foot-Wide Building.....	130
Table E7-68 Inverted Single L-Header Assembly Spans - Uplift Loading Headers Supporting Two Floors, Roof and Ceiling 32-Foot-Wide Building.....	131
Table E7-69 Inverted Single L-Header Assembly Spans - Uplift Loading Headers Supporting Two Floors, Roof and Ceiling 36-Foot-Wide Building.....	131
Table E7-70 Inverted Single L-Header Assembly Spans - Uplift Loading Headers Supporting Two Floors, Roof and Ceiling 40-Foot-Wide Building.....	132
Table E7-71 Jack and King Studs Required at Each End of an Opening.....	133
Table E7-72 Head and Sill Track Span.....	133
Table E8-1 Minimum Percentage of Full-Height Structural Sheathing on Braced Wall Line...	134
Table E8-2 Minimum Percentage of Full-Height Structural Sheathing on Braced Wall Line...	134
Table E8-3 Minimum Percentage of Full-Height Structural Sheathing on Braced Wall Line...	134
Table E8-4 Full-Height Sheathing Length Adjustment Factors.....	135
Table E8-5 Full-Height Sheathing Length Adjustment Factors.....	135
Table E11-1 Full-Height Sheathing Length Adjustment Factors Based Upon Edge Screw Spacing.....	135
Table E11-2 Type II Braced Wall Full-Height Sheathing Length Adjustment Factors.....	135
Table E12-1 SDC D ₀ Type I Sidewall Sheathing for Top of One- or Two-Story Building (Normal Roof and Heavy Wall Systems).....	136
Table E12-2 SDC D ₀ Type I Sidewall Sheathing for Bottom of Two-Story Building (Normal Roof and Heavy Wall Systems).....	136
Table E12-3 SDC D ₀ Type I Sidewall Sheathing for Top of Three-Story Building (Normal Roof and Heavy Wall Systems).....	137
Table E12-4 SDC D ₀ Type I Sidewall Sheathing for Middle of Three-Story Building (Normal Roof and Heavy Wall Systems).....	137
Table E12-5 SDC D ₀ Type I Sidewall Sheathing for Bottom of Three-Story Building (Normal Roof and Heavy Wall Systems).....	138
Table E12-6 SDC D ₁ Type I Sidewall Sheathing for Top of One- or Two-Story Building (Normal Roof and Heavy Wall Systems).....	139

Table E12-7 SDC D ₁ Type I Sidewall Sheathing for Bottom of Two-Story Building (Normal Roof and Heavy Wall Systems)	139
Table E12-8 SDC D ₁ Type I Sidewall Sheathing for Top of Three-Story Building (Normal Roof and Heavy Wall Systems)	140
Table E12-9 SDC D ₁ Type I Sidewall Sheathing for Middle of Three-Story Building (Normal Roof and Heavy Wall Systems)	140
Table E12-10 SDC D ₁ Type I Sidewall Sheathing for Bottom of Three-Story Building (Normal Roof and Heavy Wall Systems)	141
Table E12-11 SDC D ₂ Type I Sidewall Sheathing for Top of One- or Two-Story Building (Normal Roof and Heavy Wall Systems)	142
Table E12-12 SDC D ₂ Type I Sidewall Sheathing for Bottom of Two-Story Building (Normal Roof and Heavy Wall Systems)	142
Table E12-13 SDC D ₂ Type I Sidewall Sheathing for Top of Three-Story Building (Normal Roof and Heavy Wall Systems)	143
Table E12-14 SDC D ₂ Type I Sidewall Sheathing for Middle of Three-Story Building (Normal Roof and Heavy Wall Systems)	143
Table E12-15 SDC D ₂ Type I Sidewall Sheathing for Bottom of Three-Story Building (Normal Roof and Heavy Wall Systems)	144
Table E12-16 Braced Wall Full-Height Sheathing Length Adjustment Factors for Roof and Exterior Wall System Weights	145
Table E12-17 Required Hold-Down Anchor and Chord Stud Strengths - Seismic.....	145
Table E12-18 Required Shear Anchorage for Braced Walls	145
Table E12-19 Allowable Chord Stud Strength	145
Table E12-20 Top Track Thickness and Splice Screw Requirements	146
Table E13-1 Range of Allowable Sidewall Lengths (One-Story Slab on Grade)	147
Table E13-2 Range of Allowable Sidewall Lengths (All Other Cases)	147
Table E13-3 Type I Braced Wall Panel Sidewall Sheathing Length Requirements.....	148
Table E13-4 Type I Braced Wall Panel Endwall Sheathing Length Requirements.....	149
Table E13-5 Required Uplift Strength Wall Assembly to Wall Assembly	150
Table E13-6 Uplift Strap Connection Requirements Wall Assembly to Wall Assembly	151
Table E13-7 Required Uplift Strength Roof Rafter or Roof Truss to Wall	152
Table E13-8 Uplift Strap Connection Requirements Roof Rafter or Roof Truss to Wall.....	153
Table E13-9 Minimum Size of Steel Uplift Strap	154
Table E13-10 Required Hold-Down Anchor and Chord Stud Strengths - Wind.....	154
Table F2-1 Ceiling Joist Spans Single Spans Without Bearing Stiffeners 10 lbs per Square Foot Live Load (No Attic Storage)	173
Table F2-2 Ceiling Joist Spans Single Spans Without Bearing Stiffeners 20 lbs per Square Foot Live Load (Limited Attic Storage).....	174
Table F2-3 Screws Required for Ceiling Joist to Roof Rafter Connections.....	175
Table F2-4 Roof Framing Fastening Schedule.....	176
Table F2-5 Minimum Roof Sheathing Attachment for Wind Loads.....	177
Table F3-1 Roof Rafter Spans.....	178
Table F3-2 Conversion of Basic Wind Speed to Equivalent Snow Load	179
Table F3-3 Screws Required at Each Leg of Clip Angle for Hip Rafter to Hip Member or Roof Rafter to Ridge Member Connection	179
Table F4-1 Hip Member Sizes.....	180
Table F4-2 Hip Support Column Sizes.....	180
Table F4-3 Uplift Strap Connection Requirements Hip Support Column at Ceiling Line	181

Table F4-4 Connection Requirements Hip Member to Hip Support Column.....	181
Table F4-5 Uplift Strap Connection Requirements Hip Member to Wall	182
Table F5-1 Built-Up Header Size for 6-Foot Roof Opening.....	182
Table F5-2 Built-Up Header Size for 6-Foot Roof Opening.....	183
Table F5-3 Built-Up Header Size for 8-Foot Roof Opening.....	183
Table F5-4 Built-Up Header Size for 8-Foot Roof Opening.....	184
Table F5-5 Built-Up Header Size for 6- or 8-Foot Ceiling Openings	184
Table F7-1 Required Lengths for Ceiling Diaphragms at Gable Endwalls Gypsum Board Sheathed Ceiling Height = 8 ft.....	185
Table F7-2 Required Lengths for Ceiling Diaphragms at Gable Endwalls Gypsum Board Sheathed Ceiling Height = 9 or 10 ft.....	186
Table F7-3 Required Lengths for Ceiling Diaphragms at Gable Endwalls Wood Structural Panel Sheathed Ceiling Height = 8 ft.....	187
Table F7-4 Required Lengths for Ceiling Diaphragms at Gable Endwalls Wood Structural Panel Sheathed Ceiling Height = 9 or 10 ft.....	188
Table F8-1 Required Uplift Strength Roof Rafter or Roof Truss to Wall.....	189
Table F8-2 Uplift Strap Connection Requirements Roof Rafter or Roof Truss to Wall.....	190
Table F8-3 Ridge Tension Strap Connection Requirements per Foot of Ridge Span	191
Table F8-4 Framing Spacing Multiplier for Use With Table F8-3.....	192
Table F8-5 Minimum Size of Steel Uplift Strap or Ridge Strap	192

This Page is Intentionally Left Blank.

STANDARD FOR COLD-FORMED STEEL FRAMING — PRESCRIPTIVE METHOD FOR ONE- AND TWO-FAMILY DWELLINGS

A. GENERAL

A1 Scope

The provisions in this Standard shall apply to the construction of detached one- and two-family dwellings, townhouses, and other attached single-family dwellings not more than three stories in height using *repetitive in-line framing* practices.

Buildings complying with the limitations herein shall be constructed in accordance with this Standard and Chapters A and C of AISI S240. Alternatively, such dwellings are permitted to be designed by a *design professional*.

Exception: The design and installation of *cold-formed steel nonstructural members* is permitted to be in accordance with AISI S220.

This Standard shall not preclude the use of other materials, assemblies, structures or designs not meeting the criteria herein when the other materials, assemblies, structures or designs demonstrate equivalent performance for the intended use to those specified in this Standard. Where there is a conflict between this Standard and other reference documents, the requirements contained within this Standard shall govern.

The *basic wind speed*, *wind exposure category* and *seismic design category* shall be determined in accordance with the *applicable building code*, or, in the absence of an *applicable building code*, ASCE 7.

This Standard shall include Chapters A through F inclusive.

A1.1 Limits of Applicability

This Standard shall be limited to buildings meeting the limitations set forth in Table A1-1.

In *high seismic areas*, the limits of applicability of this Standard shall be modified as shown in Table A1-2.

Dwellings sited in *Wind Exposure D* are permitted to be designed in accordance with the requirements for *Wind Exposure C*, provided that the *basic wind speed* for the *Wind Exposure D* site is adjusted to an equivalent *basic wind speed* for a *Wind Exposure C* site in accordance with Table A1-3.

Detached one- and two-family dwellings classified in *Seismic Design Category E*, but meeting the limitations for a *regular building* and having no floors cantilevering past exterior walls, are permitted to be designed in accordance with the requirements for *Seismic Design Category D₂*.

In *high seismic areas*, buildings in locations with ground snow loads greater than 30 psf (1.44 kN/m²) and with either a *normal weight roof/ceiling assembly* or *light weight roof/ceiling assembly* shall be constructed in accordance with the requirements for buildings with a *heavy weight roof/ceiling assembly*.

A1.2 Limitations in High Seismic Areas and High Wind Areas

In *high seismic areas*, stemwall height shall be limited to 4 feet (1220 mm) from top of footing to top of stemwall.

Buildings in *high seismic areas* and *high wind areas* shall be subject to the additional limitations of this section.

Floor and roof *diaphragm* aspect ratios shall not be less than 0.25:1 nor exceed 4:1. The *diaphragm* aspect ratio shall be determined by dividing the distance between *braced wall lines* (*diaphragm span*) by the length of the *diaphragm* parallel to the *braced wall lines*.

Floor and roof *diaphragm* plan offsets shall not exceed 4 feet (1220 mm).

Exception: Buildings where *diaphragm* plan offsets exceed four feet shall be analyzed as separate buildings, separated by a *braced wall line* or lines. See Figure A1-1.

Braced wall lines shall be placed on all exterior walls, and on interior walls as required.

Where a *braced wall line* separates two portions of a building, the required length of braced wall panels separating the two portions shall be determined by summing the required lengths of braced wall panels for each portion of the building as shown in Figure A1-1.

Vertical offsets in floor and roof *diaphragms* shall be supported by *braced wall lines*. See Figure A1-2(a).

Braced wall lines shall be continuous and in a single vertical plane from foundation to the uppermost story in which they are required.

There shall be no horizontal offsets of *braced wall lines*. See Figure A1-2(b).

A1.2.1 Irregular Buildings in High Seismic Areas and High Wind Areas

In *high seismic areas*, a building with one or more irregularities, as defined in this section, shall have an engineered lateral force-resisting system designed in accordance with the *applicable building code*.

Where an irregularity is isolated to a portion of a building and that portion of the building is designed in accordance with accepted engineering practice so that the irregularity does not affect the performance of the remaining building, the remainder of the building is permitted to be designed in accordance with the provisions of this Standard.

For the purposes of this Standard, any of the following conditions constitute an irregularity:

- (1) When exterior *braced wall lines* are not in one plane vertically from the foundation to the uppermost story in which they are required.
- (2) When a section of a floor or roof is not laterally supported by *braced wall lines* on all edges.

Exception: Portions of floors that do not support *Type I* or *Type II braced walls* above, or roofs, are permitted to extend not more than 6 feet (1829 mm) beyond a *braced wall line*. See Figure A1-3.

- (3) When an opening in a floor or roof exceeds the lesser of 12 feet (3658 mm) or 50 percent of the least floor or roof dimension.
- (4) When portions of a floor are vertically offset and not supported by a *braced wall line*.
- (5) When *braced wall lines* do not occur in two perpendicular directions.
- (6) When a *braced wall line* is constructed of dissimilar *bracing* systems or *braced wall lines* in a given plan direction on any one level above grade are constructed of dissimilar *bracing* systems.

A2 Definitions

Where terms appear in this Standard in italics, such terms shall have the meaning as defined in Section A2.1 of AISI S240 or as defined herein. Where terms are included in both this

Standard and Section A2.1 of AISI S240, such terms shall have the meaning as defined herein. Where terms are not included, such terms shall have ordinary accepted meaning in the context for which they are intended.

Basic Wind Speed. The 3-second gust wind speed.

Braced Wall Line. A straight line through the building plan that represents the location of the lateral resistance provided by the wall bracing.

Eave Height. The distance from the ground surface adjacent to the building to the roof eave line at a particular wall. If the height of the eave varies along the wall, the average height shall be used.

Heavy Weight Roof/Ceiling Assembly. A roof/ceiling assembly with an average unit weight greater than 15 psf (0.72 kN/m²) and less than or equal to 25 psf (1.20 kN/m²).

Heavy Weight Exterior Walls. An exterior wall with a unit weight greater than 7 psf (0.34 kN/m²) and less than or equal to 14 psf (0.68 kN/m²).

High Seismic Area. An area where the *Seismic Design Category* is D_0 , D_1 , D_2 or E .

High Wind Area. An area where *basic wind speeds* are equal to 140 mph (225 km/hr) up to and including 180 mph (290 km/hr).

Light Weight Roof/Ceiling Assembly. A roof/ceiling assembly with an average unit weight less than or equal to 12 psf (0.51 kN/m²).

Light Weight Exterior Walls. An exterior wall with a unit weight less than or equal to 7 psf (0.34 kN/m²).

Limited Attic Storage. Attic where the maximum clear height between *joist* and *roof rafter* is greater than or equal to 42 inches and the attic area is accessible by a pull-down stairway or framed opening.

Normal Weight Roof/Ceiling Assembly. A roof/ceiling assembly with an average unit weight greater than 12 psf (0.51 kN/m²) and less than or equal to 15 psf (0.72 kN/m²).

No Attic Storage. Attic where the maximum clear height between *joist* and *roof rafter* is less than 42 inches.

Risk Category. A categorization of buildings and other structures for determination of flood, wind, snow, ice, and earthquake loads based on the risk associated with unacceptable performance.

SDC D_0 . The *Seismic Design Category* corresponding to a calculated Short Period Design Spectral Response Acceleration greater than 0.50g, and less than or equal to 0.67g.

SDC D_1 . The *Seismic Design Category* corresponding to a calculated Short Period Design Spectral Response Acceleration greater than 0.67g, and less than or equal to 0.83g.

SDC D_2 . The *Seismic Design Category* corresponding to a calculated Short Period Design Spectral Response Acceleration greater than 0.83g, and less than or equal to 1.25g.

SDC E . The *Seismic Design Category* corresponding to a calculated Short Period Design Spectral Response Acceleration greater than 1.25g.

Seismic Design Category (SDC). A classification assigned by the *applicable building code* to a structure based upon its *risk category* and the severity of the design earthquake ground motion at the site.

Wind Exposure Category. A classification assigned to a building based upon the characteristics of the ground surface irregularities at the building site.

Wind Exposure B. Urban and suburban areas, wooded areas or other terrain with numerous closely spaced obstructions having the size of single-family dwellings or larger.

Wind Exposure C. Open terrain with scattered obstructions, including surface undulations or other irregularities, having heights generally less than 30 feet (9144 mm) extending more than 1,500 feet (457 m) from the building site in any quadrant. This exposure shall also apply to any building located within Exposure B type terrain where the building is directly adjacent to open areas of Exposure C type terrain in any quadrant for a distance of more than 600 feet (183 m). This category includes flat, open country and grasslands.

Wind Exposure D. Flat, unobstructed areas exposed to wind flowing over open water, smooth mud flats, salt flats and unbroken ice for a distance of not less than 5,000 feet (1524 m). This exposure shall apply only to those buildings and other structures exposed to the wind coming from over the unobstructed area. Exposure D extends downwind from the edge of the unobstructed area a distance of 600 feet (183 m) or 20 times the height of the building or structure, whichever is greater.

A3 Referenced Documents

The following documents or portions thereof are referenced within this Standard and shall be considered part of the requirements of this document.

1. AISI S201-12, *North American Standard for Cold-Formed Steel Framing – Product Data*, American Iron and Steel Institute, Washington, DC.
2. AISI S220-15, *North American Standard for Cold-Formed Steel Framing – Nonstructural Members*, American Iron and Steel Institute, Washington, DC.
3. AISI S240-15, *North American Standard for Cold-Formed Steel Structural Framing*, American Iron and Steel Institute, Washington, DC.
4. ASCE 7-10 Including Supplement 1, *Minimum Design Load for Buildings and Other Structures*, American Society of Civil Engineers, Reston, VA.
5. ASTM A307-12, *Standard Specification for Carbon Steel Bolts and Studs, 60000 PSI Tensile Strength*, ASTM International, West Conshohocken, PA.
6. ASTM A1003/A1003M-15, *Standard Specification for Steel Sheet, Carbon, Metallic and Non-Metallic-Coated for Cold-Formed Framing Members*, ASTM International, West Conshohocken, PA.
7. ASTM F1554-07, *Standard Specification for Anchor Bolts, Steel, 36, 55, and 105-ksi Yield Strength*, ASTM International, West Conshohocken, PA.
8. CSA O325-07 (R2012), *Construction Sheathing*, Canadian Standards Association, Mississauga, Ontario, Canada.
9. CSA O437-Series-93 (R2011), *Standards on OSB and Waferboard*, Canadian Standards Association, Mississauga, Ontario, Canada.
10. DOC PS 1-09, *Structural Plywood*, United States Department of Commerce, National Institute of Standards and Technology, Gaithersburg, MD.
11. DOC PS 2-10, *Performance Standard for Wood-Based Structural-Use Panels*, United States Department of Commerce, National Institute of Standards and Technology, Gaithersburg, MD.

A4 Limitations of Framing Members

A4.1 General

Structural members and nonstructural members shall comply with AISI S201 and the additional limitations of this section. Such limitations shall not apply where design is provided by a *design professional*.

A4.2 Sheathing Span Capacity

A4.2.1 Floor Framing

Floor joist and *floor truss* spacing shall not exceed the span capacity of the floor *structural sheathing* material.

A4.2.2 Wall Framing

Wall *stud* spacing shall not exceed the span capacity of the wall *structural sheathing* material.

A4.2.3 Roof and Ceiling Framing

The spacing of roof and ceiling framing members shall not exceed the span capacity of the ceiling or roof *structural sheathing* material.

A4.3 Physical Dimensions

Cold-formed steel structural members shall comply with the dimensional requirements specified in Table A4-1.

A4.4 Material Properties

The minimum *yield strength*, F_y , of *cold-formed steel structural members and nonstructural members* shall be 33 ksi (230 MPa) unless otherwise specified as 50 ksi (340 MPa). Where specified using the tables in this Standard, the minimum *yield strength*, F_y , of *cold-formed steel structural members and nonstructural members* shall be 50 ksi (340 MPa) for members with a *designation thickness* equal to or greater than 54 mils (1.37 mm).

A4.4.1 Material Properties in High Wind Areas and High Seismic Areas

Steel sheet used as a wall *bracing* material in *high wind areas* and *high seismic areas* shall have a minimum *base steel thickness* of 0.0269 inches (0.683 mm) and shall be of ASTM A1003 Structural Grade 33 (Grade 230) Type H steel.

A4.5 Web Holes

Holes in *webs* of *structural members* shall comply with the requirements for factory *punchouts* (perforations) in Section C5 of AISI S201, as shown in Figure A4-1, and all the following requirements:

- (1) *Web* hole width for *studs* shall not be greater than 1-1/2 inches (38.1 mm).
- (2) Minimum distance between the edge of bearing and the near edge of a *web* hole shall be 10 inches (254 mm), as shown in Figure A4-2.

Members with holes violating the above requirements shall be reinforced in accordance with Section A4.6, patched in accordance with Section A4.7, or designed in accordance with accepted engineering practices.

A4.6 Hole Reinforcing

Web holes in *floor joists*, *ceiling joists* and gable endwall *studs* violating the requirements of

Section A4.5 are permitted to be reinforced if the hole is located fully within the center 40 percent of the *span* and the depth and length of the hole does not exceed 65% of the flat width of the *web*. The reinforcing shall be a steel plate or *C-shape* section with a hole that does not exceed the above *web* hole size limitation for the member being reinforced. The steel reinforcing shall be of a minimum thickness as the receiving member and shall extend at least 1 inch (25.4 mm) beyond all edges of the hole. The steel reinforcing shall be fastened to the *web* of the receiving member with No. 8 screws spaced no greater than 1 inch (25.4 mm) center-to-center along the edges of the patch with minimum edge distance of 1/2 inch (12.7 mm).

A4.7 Hole Patching

Web holes violating the requirements of Section A4.5 are permitted to be patched if the depth of the hole does not exceed 70% of the flat width of the *web* and the length of the hole measured along the *web* does not exceed 10 inches (254 mm) or the depth of the *web*, whichever is greater. The patch shall be a solid steel plate, *stud* section, or *track* section in accordance with Figures A4-3 or A4-4. The steel patch shall be of a minimum thickness as the receiving member and shall extend at least 1 inch (25.4 mm) beyond all edges of the hole. The steel patch shall be fastened to the *web* of the receiving member with No. 8 screws spaced no greater than 1 inch (25.4 mm) center-to-center along the edges of the patch with minimum edge distance of 1/2 inch (12.7 mm).

Structural members shall be replaced or designed in accordance with accepted engineering practices when *web* holes exceed either of the following size limits:

- (a) The depth of the hole, measured across the *web*, exceeds 70% of the flat width of the *web*.
- (b) The length of the hole measured along the *web* exceeds 10 inches (254 mm) or the depth of the *web*, whichever is greater.

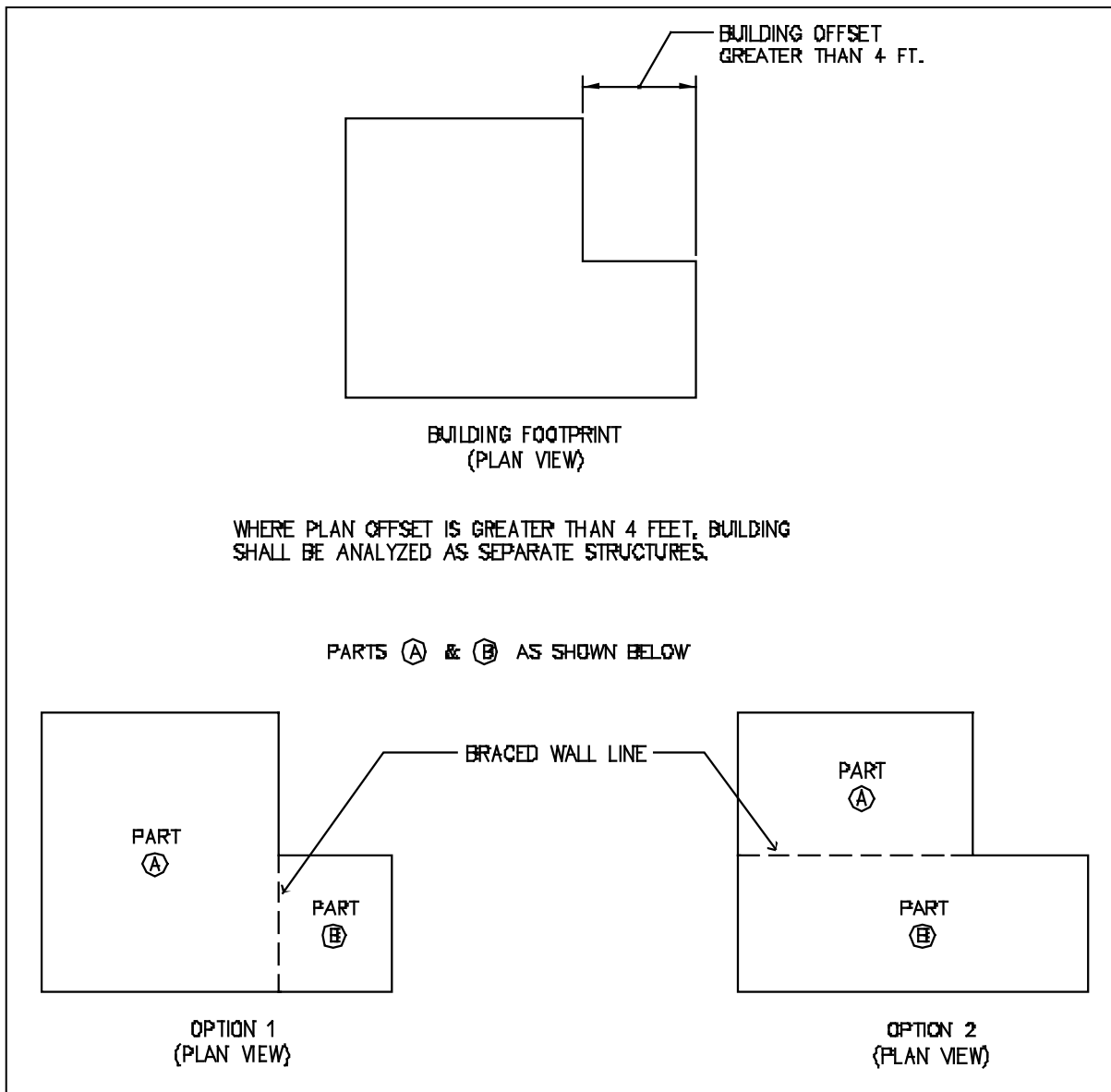

Figure A1-1 Building Configuration

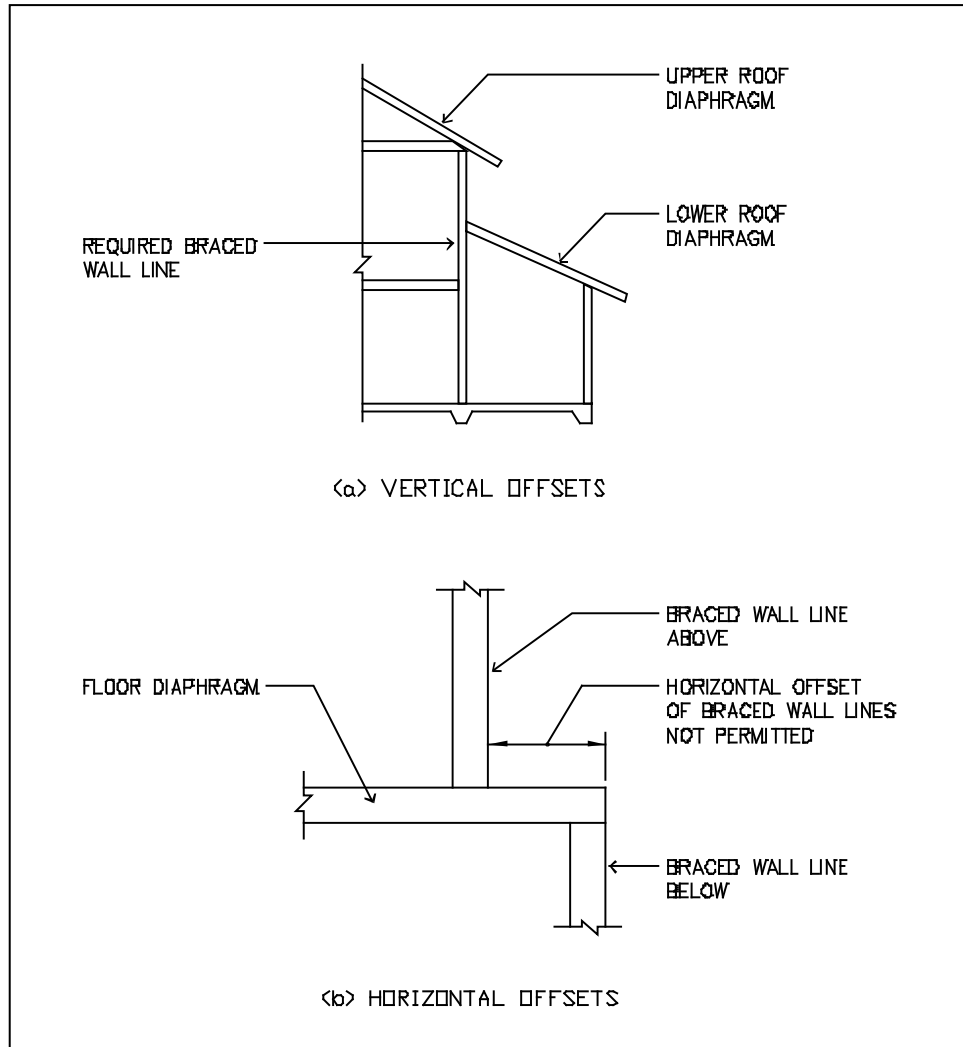

Figure A1-2 Building Configuration Limitations

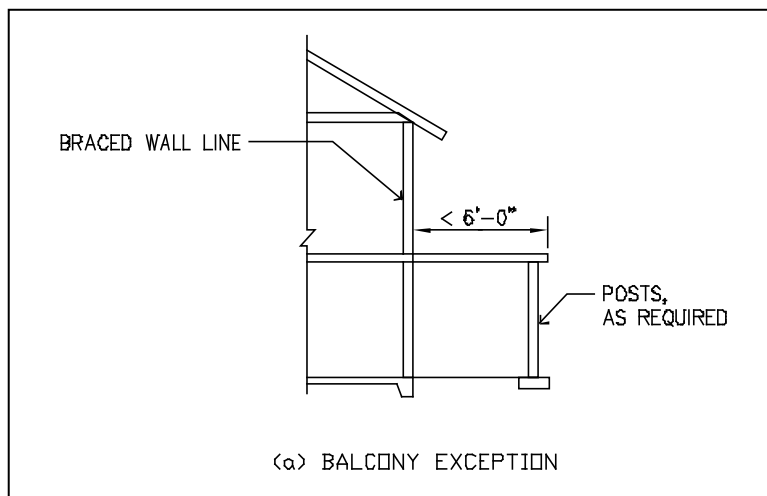

Figure A1-3 Irregular Buildings

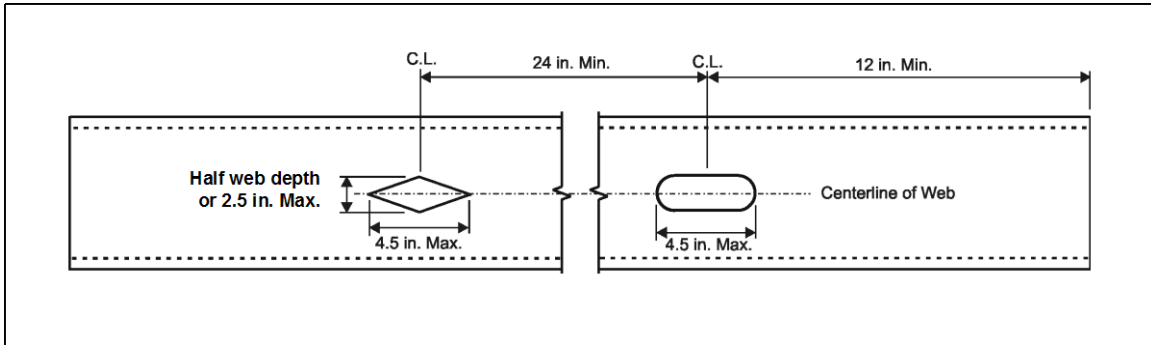

Figure A4-1 Web Hole Limitations

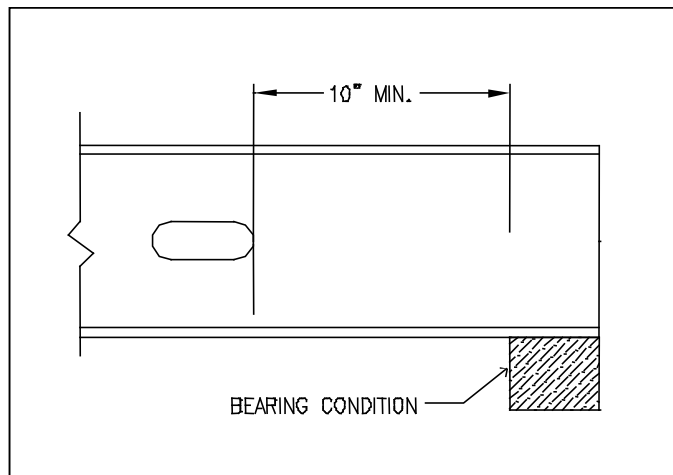

Figure A4-2 Web Hole Limitation Adjacent to Bearing

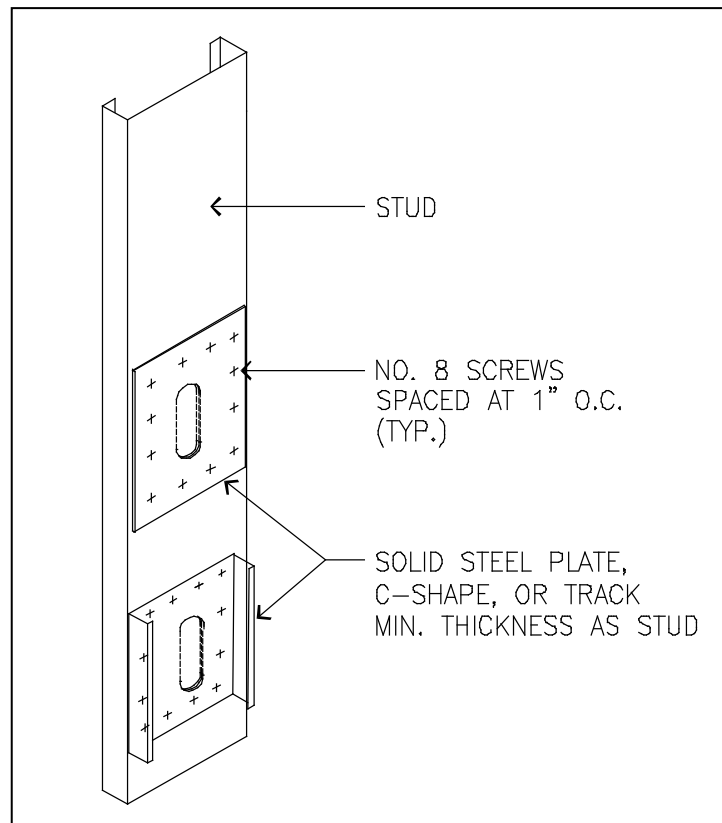

Figure A4-3 Stud Web Hole Patch

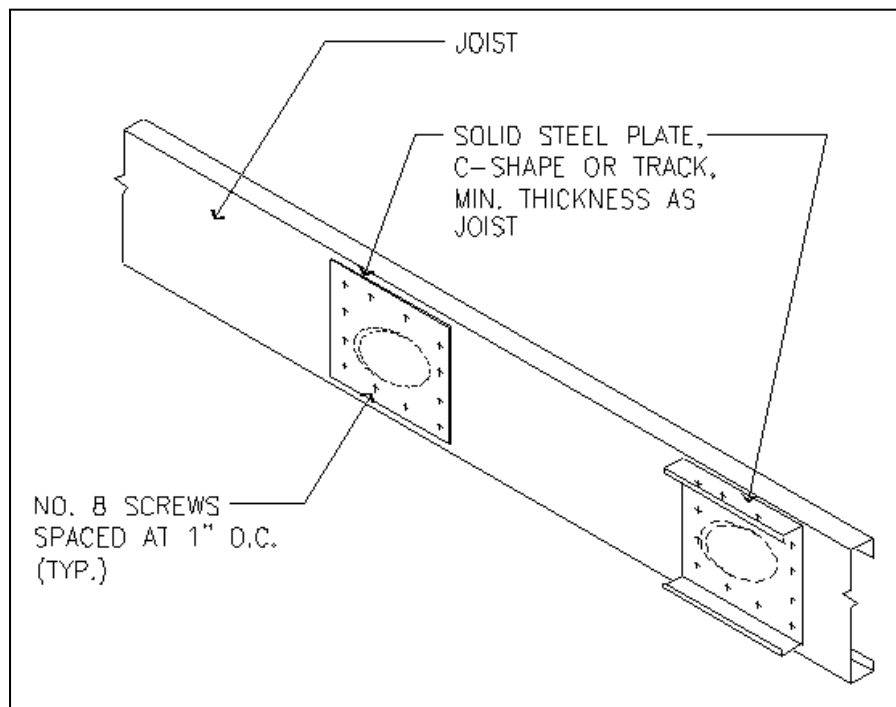

Figure A4-4 Joist Web Hole Patch

Table A1-1
Limits of Applicability

ATTRIBUTE	LIMITATION
General	
Building Dimension	Maximum width ¹ is 40 feet (12.2 m) Maximum length ² is 60 feet (18 m)
Number of Stories	3 stories with a basement
Maximum Story Height	11 feet 7 inches (3.53 m) with a maximum wall stud height of not more than 10 feet (3.05 m)
Maximum Mean Roof Height	33 feet (10.1 m) above <i>average grade</i>
Basic Wind Speed and Wind Exposure	<i>Wind Exposures B and C</i> : Up to 180 mph (290 km/hr) <i>Wind Exposure D</i> : Up to 166 mph (267 km/hr)
Ground Snow Load	70 psf (3.35 kN/m ²) maximum ground snow load
Seismic Design Category	A, B, C, D ₀ , D ₁ , D ₂ and E
Floors	
Floor Dead Load	10 psf (0.48 kN/m ²) maximum
Floor Live Load	40 psf (1.92 kN/m ²) maximum (rooms other than sleeping rooms) 30 psf (1.44 kN/m ²) maximum (sleeping rooms)
Cantilever	24 inches (610 mm) maximum
Walls	
Wall Dead Load	10 psf (0.48 kN/m ²) maximum
Structural Wall Height	10 feet (3.05 m) maximum
Roofs	
Roof Dead Load	12 psf (0.58 kN/m ²) maximum total roof and ceiling load 7 psf (0.34 kN/m ²) maximum for roof covering only
Roof Snow/Live Load	70 psf (3.35 kN/m ²) maximum ground snow load (16 psf (0.77 kN/m ²) minimum roof live load)
Ceiling Dead Load	5 psf (0.24 kN/m ²) maximum
Roof Slope	3:12 to 12:12
Rake Overhang	12 inches (305 mm) maximum
Eave Overhang	24 inches (610 mm) maximum
Attic Live Load (Attics with storage)	20 psf (0.96 kN/m ²) maximum
Attic Live Load (Attics without storage)	10 psf (0.48 kN/m ²) maximum

For SI: 1 inch = 25.4 mm, 1 psf = 0.0479 kN/m², 1 mph = 1.61 km/hr = 0.447 m/sec, 1 foot = 0.305 m.

¹ Building width is in the direction of horizontal framing members supported by the wall studs.

² Building length is in the direction perpendicular to floor joists, ceiling joists, or roof trusses.

Table A1-2
Additional Limitations in High Seismic Areas

ATTRIBUTE	LIMITATION
General	
Number of Stories	3 story slab on grade or on continuous concrete or masonry foundation ¹
Ground Snow Load ³	70 psf (3.35 kN/m ²) maximum with <i>normal</i> or <i>light weight</i> ² roof assembly 30 psf (1.44 kN/m ²) maximum with <i>heavy weight</i> ² roof assembly
Seismic Design Category	Seismic Design Category D ₀ , D ₁ , D ₂ , E ⁴
Walls	
Wall Dead Load	7 psf (0.34 kN/m ²) maximum for <i>light weight exterior wall</i> system 14 psf (0.68 kN/m ²) maximum for <i>heavy weight exterior wall</i> system
Roofs	
Roof/Ceiling Dead Load	12 psf (0.57 kN/m ²) maximum total load for <i>light weight roof assembly</i> 15 psf (0.72 kN/m ²) maximum total load for <i>normal weight roof assembly</i> 25 psf (1.20 kN/m ²) maximum total load for <i>heavy weight roof assembly</i>
Roof Slope	3:12 to 6:12

For SI: 1 inch = 25.4 mm, 1 psf = 0.0479 kN/m², 1 mph = 1.61 km/hr = 0.447 m/s, 1 foot = 0.305 m

¹ Maximum height from *average grade* to *mean roof height* is limited to 33' (10.1 m).

² *Normal*, *light*, and *heavy weight roof assemblies* are as defined in this table.

³ In *high seismic areas*, buildings in locations with ground snow loads greater than 30 psf (1.44 kN/m²) and with a *normal* or *light weight roof/ceiling assembly* are to be constructed in accordance with the requirements for buildings with a *heavy weight roof/ceiling assembly*.

⁴ Buildings constructed in *Seismic Design Category E* per this Standard are limited to *regular buildings* which do not have any floors cantilevered past exterior walls.

Table A1-3
Equivalent Basic Wind Speed Adjustment
Between Wind Exposure D Sites and Wind Exposure C Sites

Wind Exposure D	Basic Wind Speed (mph)							
	≤106	≤110	≤120	≤129	≤138	≤147	≤156	≤166
Equivalent Wind Exposure C	115	120	130	140	150	160	170	180

Table A4-1
Cold-Formed Steel Member Sizes

Member Designation ¹	Web Depth (inches)	Minimum Flange Width (inches)	Maximum Flange Width (inches)
350S162-t	3.5	1.625	2
550S162-t	5.5	1.625	2
800S162-t	8	1.625	2
1000S162-t	10	1.625	2
1200S162-t	12	1.625	2

For SI: 1 inch = 25.4 mm

B. CONNECTIONS

B1 Fastening Requirements

Screw fasteners shall conform to the requirements of Section D1 of AISI S220 and Section B1.5.1 of AISI S240, as applicable. All screw sizes specified in this Standard shall be minimums. Other fastening techniques, such as the use of pneumatically driven fasteners, power-actuated fasteners, crimping, clinching, or welding, are permitted when *approved*.

Where No. 8 screws are specified but larger screws are used, the required number of screws in a steel-to-steel connection is permitted to be reduced in accordance with the reduction factors in Table B1-1 when larger screws are used or when the sheets of steel being connected are thicker than 33 mils (0.84 mm). When applying the reduction factor, the resulting number of screws shall be rounded up.

B2 Bearing Stiffeners

A *bearing stiffener* shall be fabricated from a *C-shaped*, *track* or clip angle member with a minimum size that is in accordance with one of the following:

1. *C-shaped* Bearing Stiffeners:
 - a. Where the *joist* is not carrying a structural wall above, the *bearing stiffener* shall be a minimum 33 mil (0.84 mm) thickness.
 - b. Where the *joist* is carrying a structural wall above, the *bearing stiffener* shall be at least the same *designation thickness* as the wall *stud* above.
2. *Track* Bearing Stiffeners:
 - a. Where the *joist* is not carrying a structural wall above, the *bearing stiffener* shall be a minimum 43 mil (1.09 mm) thickness.
 - b. Where the *joist* is carrying a structural wall above, the *bearing stiffener* shall be at least one *designation thickness* greater than the wall *stud* above.
3. Clip Angle Bearing Stiffeners:
 - a. Where the clip angle *bearing stiffener* is fastened to both the *web* of the member it is stiffening and an adjacent *rim track* using the fastener pattern shown in Figure B2-1, the *bearing stiffener* shall be a minimum 2-inch x 2-inch (51 mm x 51 mm) angle sized in accordance with Tables B2-1 through B2-4.

The minimum length of a *bearing stiffener* shall be the depth of the member being stiffened minus 3/8 inch (9.5 mm). Each *bearing stiffener* shall be fastened to the *web* of the member it is stiffening as shown in Figure B2-1. Each clip angle *bearing stiffener* shall also be fastened to the *web* of the adjacent *rim track* using the fastener pattern shown in Figure B2-1. No. 8 screws shall be used for *C-shaped* and *track* members of any thickness and for clip angle members with a *designation thickness* less than or equal to 54 mils (1.37 mm). No. 10 screws shall be used for clip angle members with a *designation thickness* greater than 54 mils (1.37 mm). *Bearing stiffeners* shall be installed in accordance with the alignment requirements of Section B1.2.3 of AISI S240 for inline framing.

B3 Clip Angles

Clip angles shall have a minimum size of 2 inches x 2 inches by 33 mil (51 mm x 51 mm by 0.84 mm) and have sufficient leg length to provide minimum 1-inch (25.4 mm) overlap on the connected material, unless otherwise noted. All *clip angle* materials shall comply with Sections A4.1 and A4.4.

B4 Anchor Bolts

Anchor bolts connecting steel framing to the foundation structure shall be installed so that the distance from the center of the bolt hole to the edge of the connected member is not less than one and one-half bolt diameters. Anchor bolts shall include appropriate size and grade washers. Anchor bolts shall meet or exceed the requirements of ASTM F1554.

In *high wind areas* and *high seismic areas*, anchor bolts shall have a minimum 3" x 3" x 0.229" (76 mm x 76 mm x 5.8 mm) steel plate washer, unless a standard hole size is provided in the connected member and a standard cut or hardened washer is provided between the connected member and the nut.

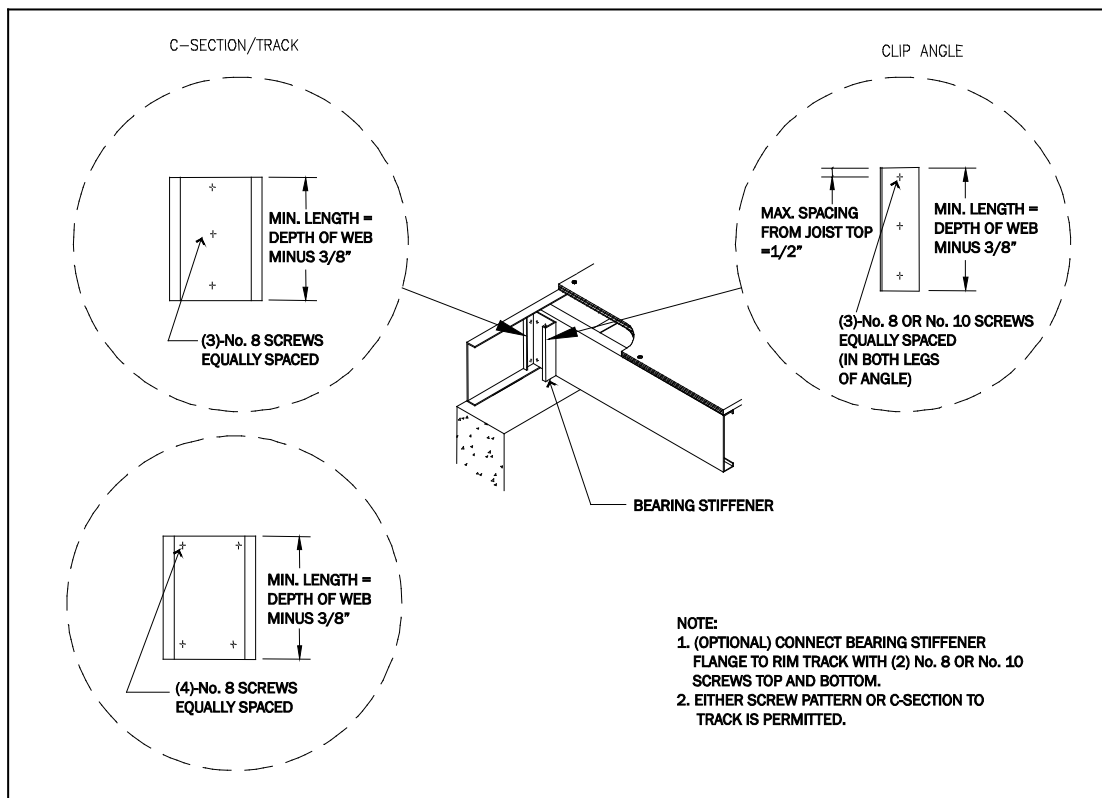

Figure B2-1 Bearing Stiffener (Web Stiffener)

**Table B1-1
Screw Substitution Factor**

Screw Size	Thinnest Connected Steel Sheet (mils)	
	33	43
No. 8	1.0	0.67
No. 10	0.93	0.62
No. 12	0.86	0.56

For SI: 1 mil = 0.0254 mm

Table B2-1
Clip Angle Bearing Stiffeners
20 psf Equivalent Snow Load

Joist Designation	Minimum Thickness (Mils) of 2-inch x 2-inch (50.8 mm x 50.8 mm) Clip Angle											
	Top Floor				Bottom Floor in 2 Story Middle Floor in 3 Story				Bottom Floor in 3 Story			
	Joist Spacing (inches)				Joist Spacing (inches)				Joist Spacing (inches)			
	12	16	19.2	24	12	16	19.2	24	12	16	19.2	24
800S162-33	43	43	43	43	43	54	68	68	68	-	-	-
800S162-43	43	43	43	43	54	54	68	68	-	-	-	-
800S162-54	43	43	43	43	43	54	68	68	68	-	-	-
800S162-68	43	43	43	43	43	43	54	68	54	-	-	-
800S162-97	43	43	43	43	43	43	43	43	43	43	54	-
1000S162-43	43	43	43	43	54	68	-	-	-	-	-	-
1000S162-54	43	43	43	43	54	68	68	-	-	-	-	-
1000S162-68	43	43	43	43	54	68	-	-	-	-	-	-
1000S162-97	43	43	43	43	43	43	43	54	43	68	-	-
1200S162-43	43	54	54	54	-	-	-	-	-	-	-	-
1200S162-54	54	54	54	54	-	-	-	-	-	-	-	-
1200S162-68	43	43	54	54	68	-	-	-	-	-	-	-
1200S162-97	43	43	43	43	43	54	68	-	-	-	-	-

For SI: 1 mil = 0.0254 mm

Table B2-2
Clip Angle Bearing Stiffeners
30 psf Equivalent Snow Load

Joist Designation	Minimum Thickness (Mils) of 2-inch x 2-inch (50.8 mm x 50.8 mm) Clip Angle											
	Top Floor				Bottom Floor in 2 Story Middle Floor in 3 Story				Bottom Floor in 3 Story			
	Joist Spacing (inches)				Joist Spacing (inches)				Joist Spacing (inches)			
	12	16	19.2	24	12	16	19.2	24	12	16	19.2	24
800S162-33	43	43	43	43	54	68	68	-	-	-	-	-
800S162-43	43	43	43	54	68	68	68	-	-	-	-	-
800S162-54	43	43	43	43	54	68	68	-	-	-	-	-
800S162-68	43	43	43	43	43	54	68	-	68	-	-	-
800S162-97	43	43	43	43	43	43	43	43	43	43	68	-
1000S162-43	54	54	54	54	68	-	-	-	-	-	-	-
1000S162-54	54	54	54	54	68	-	-	-	-	-	-	-
1000S162-68	43	43	54	68	68	-	-	-	-	-	-	-
1000S162-97	43	43	43	43	43	43	54	68	54	-	-	-
1200S162-43	54	68	68	68	-	-	-	-	-	-	-	-
1200S162-54	68	68	68	68	-	-	-	-	-	-	-	-
1200S162-68	68	68	68	68	-	-	-	-	-	-	-	-
1200S162-97	43	43	43	43	54	68	-	-	-	-	-	-

For SI: 1 mil = 0.0254 mm

Table B2-3
Clip Angle Bearing Stiffeners
50 psf Equivalent Snow Load

Joist Designation	Minimum Thickness (Mils) of 2-inch x 2-inch (50.8 mm x 50.8 mm) Clip Angle											
	Top Floor				Bottom Floor in 2 Story Middle Floor in 3 Story				Bottom Floor in 3 Story			
	Joist Spacing (inches)				Joist Spacing (inches)				Joist Spacing (inches)			
	12	16	19.2	24	12	16	19.2	24	12	16	19.2	24
800S162-33	54	54	54	54	68	97	97	97	97	-	-	-
800S162-43	68	68	68	68	97	97	97	97	-	-	-	-
800S162-54	54	68	68	68	97	97	97	97	-	-	-	-
800S162-68	43	43	54	54	68	97	97	97	97	-	-	-
800S162-97	43	43	43	43	43	43	43	54	54	68	97	-
1000S162-43	97	68	68	68	97	97	97	97	-	-	-	-
1000S162-54	97	97	68	68	97	97	97	-	-	-	-	-
1000S162-68	68	97	97	97	97	-	-	-	-	-	-	-
1000S162-97	43	43	43	43	54	68	97	97	-	-	-	-
1200S162-43	97	97	97	97	-	-	-	-	-	-	-	-
1200S162-54	-	97	97	97	-	-	-	-	-	-	-	-
1200S162-68	97	97	97	97	-	-	-	-	-	-	-	-
1200S162-97	54	68	68	97	97	-	-	-	-	-	-	-

For SI: 1 mil = 0.0254 mm

Table B2-4
Clip Angle Bearing Stiffeners
70 psf Equivalent Snow Load

Joist Designation	Minimum Thickness (Mils) of 2-inch x 2-inch (50.8 mm x 50.8 mm) Clip Angle											
	Top Floor				Bottom Floor in 2 Story Middle Floor in 3 Story				Bottom Floor in 3 Story			
	Joist Spacing (inches)				Joist Spacing (inches)				Joist Spacing (inches)			
	12	16	19.2	24	12	16	19.2	24	12	16	19.2	24
800S162-33	68	68	68	68	97	97	97	97	-	-	-	-
800S162-43	97	97	97	97	97	97	97	-	-	-	-	-
800S162-54	97	97	97	97	97	-	-	-	-	-	-	-
800S162-68	68	68	68	97	97	97	97	-	-	-	-	-
800S162-97	43	43	43	43	43	54	68	97	97	97	-	-
1000S162-43	97	97	97	97	-	-	-	-	-	-	-	-
1000S162-54	-	97	97	97	-	-	-	-	-	-	-	-
1000S162-68	97	97	-	-	-	-	-	-	-	-	-	-
1000S162-97	68	68	68	68	97	97	-	-	-	-	-	-
1200S162-43	97	97	97	97	-	-	-	-	-	-	-	-
1200S162-54	-	-	-	-	-	-	-	-	-	-	-	-
1200S162-68	-	-	-	-	-	-	-	-	-	-	-	-
1200S162-97	97	97	97	-	-	-	-	-	-	-	-	-

For SI: 1 mil = 0.0254 mm

C. FOUNDATION

C1 General

The building foundation shall comply with the *applicable building code*. Steel framing shall be attached to the foundation structure according to the requirements of Chapters D and E of this Standard. Foundation anchor bolts shall be located not more than 12 inches (305 mm) from corners or the termination of bottom *tracks*.

D. FLOOR FRAMING

D1 Floor Construction

Floor framing shall be constructed in accordance with Sections D2 to D9, as applicable.

D2 Floor to Foundation or Structural Wall Connection

Floor framing shall be anchored to foundations, wood sills, or structural walls in accordance with Table D2-1 and Figures D2-1 through D2-6. Anchor bolts shall be located not more than 12 inches (305 mm) from corners or the termination of bottom *tracks*. Continuous steel *joists* supported by interior structural walls shall be constructed in accordance with Figure D2-7. Lapped steel *joists* shall be constructed in accordance with Figure D2-8. End *floor joists* constructed on foundation walls parallel to the *joist span* shall be doubled unless a *C-shaped bearing stiffener*, sized in accordance with Section B2, is installed *web-to-web* with the *floor joist* beneath each supported wall *stud*, as shown in Figure D2-9. Fastening of steel *joists* to other framing members shall be in accordance with Table D2-2.

In *high seismic areas* and *high wind areas*, the anchorage of floors to foundations and structural walls shall be in accordance with the provisions of Sections E11, E12 and E13, as applicable.

D3 Minimum Floor Joist Sizes

Floor joist size and thickness shall be determined in accordance with the limits set forth in Table D3-1 for *single spans*.

When continuous two-span (excluding cantilever) *joist* members are used, the interior bearing supports shall be located within two feet (0.61 m) of the mid-point along the length of the steel *joists*, and the individual *spans* shall not exceed the *spans* in Tables D3-1. **Exception:** Table D3-1 is not applicable for 800S162-33 and 1000S162-43 continuous *joist* members.

Floor joists shall have a bearing support length of not less than 1.5 inches (38 mm) for exterior wall supports and 3.5 inches (89 mm) for interior wall supports. *Tracks* shall be a minimum of 33 mils (0.84 mm) thick except when used as part of the floor *header* or trimmer in accordance with Section D7.

D3.1 Floor Cantilevers

Floor cantilevers for the top floor of a two- or three-story building or the first floor of a one-story building shall not exceed 24 inches (610 mm). Cantilevers, not exceeding 24 inches (610 mm) and supporting two stories and roof (i.e., first floor of a two-story building), are permitted provided that all cantilevered *joists* are doubled (nested or back-to-back). The doubled cantilevered *joists* shall extend a minimum of 6 feet (1.83 m) toward the inside and shall be fastened with a minimum of two No. 8 screws spaced at 24 inches (610 mm) on center through the *webs* (for back-to-back) or *flanges* (for nested *joists*).

D4 Bearing Stiffeners

Bearing stiffeners shall be installed at each *joist* bearing location in accordance with Section B2, except for *joists* lapped over an interior support not carrying a structural wall above. Floor *joists* supporting jamb *studs* with multiple members shall have two *bearing stiffeners* in accordance with Figure D4-1.

D5 Joist Bracing and Blocking

D5.1 Joist Top Flange Bracing

The top *flanges* of *floor joist* members shall be laterally braced by the application of floor

sheathing fastened to the joists in accordance with Section D9.

D5.2 Joist Bottom Flange Bracing/Blocking

Floor joists with spans that exceed 12 feet (3.66 m) shall have the bottom flanges laterally braced in accordance with one of the following:

- (a) Gypsum board installed with No. 6 screws at 12 inches (305 mm) on center on edges and in the field. Edges perpendicular to framing members need not be blocked.
- (b) Continuous steel *straps* installed in accordance with Figure D5-1. Steel *straps* shall be spaced at a maximum of 12 feet (3.66 m) on center and shall be at least 1-1/2 inches (38 mm) in width and 33 mils (0.84 mm) in thickness. *Straps* shall be fastened to the bottom *flange* of each *joist* with one No. 8 screw, fastened to *blocking* with two No. 8 screws, and fastened at each end of *strap* with two No. 8 screws. *Blocking* (Figure D5-1 or Figure D5-2) shall be installed between joists at each end of the continuous *strapping* and at a maximum spacing of 12 feet (3.66 m) measured along the continuous *strapping* (perpendicular to the *joist* run). *Blocking* shall also be located at the termination of all *straps*. As an alternative to *blocking* at the ends, the *strap* is permitted to be anchored to a stable building component with two No. 8 screws.

D5.3 Blocking at Interior Bearing Supports

Blocking is not required for continuous back-to-back *floor joists* at bearing supports. *Blocking* shall be installed between every other *joist* for single continuous *floor joists* across bearing supports in accordance with Figure D2-7. *Blocking* shall consist of *C-shape* or *track* section with a minimum thickness of 33 mils (0.84 mm). *Blocking* shall be fastened to each adjacent *joist* through a 33 mil *clip angle*, bent *web* of *blocking* or *flanges* of *web* stiffener with two No. 8 screws on each side. The minimum depth of the *blocking* shall be equal to the depth of the *joist* minus 2 inches (51 mm). The minimum length of the angle shall be equal to the depth of the *joist* minus 2 inches (51 mm).

D5.4 Blocking at Cantilevers

Blocking shall be installed between every other *joist* over cantilever bearing supports in accordance with Figures D2-4, D2-5 or D2-6. *Blocking* shall consist of *C-shape* or *track* section with minimum thickness of 33 mils (0.84 mm). *Blocking* shall be fastened to each adjacent *joist* through bent *web* of *blocking*, 33 mil *clip angle* or *flange* of *web* stiffener with two No. 8 screws at each end. The depth of the *blocking* shall be equal to the depth of the *joist*. The minimum length of the angle shall be equal to the depth of the *joist* minus 2 inches (51 mm). *Blocking* shall be fastened through the floor sheathing and to the support with 3 No. 8 screws (top and bottom).

D6 Splicing

Joists and other *structural members* shall not be spliced without an *approved* design. Splicing of *tracks* shall conform to Figure D6-1.

D7 Framing of Floor Openings

Openings in floors shall not exceed the lesser of 12 feet (3.66 m) or 50 percent of the parallel building dimension. Where the opening is less than 2 feet (0.61 m) from the exterior wall, the exterior wall adjacent to the opening shall be designed in accordance with the *applicable building code*.

Openings in floors shall be framed with *header* and trimmer joists. *Header* and trimmer joists shall be framed in accordance with Figures D7-1 and D7-2 and installed in accordance with

Figures D7-3 and D7-4. *Header* and trimmer joists shall be fabricated from *joist* and *track* members, having a minimum size and thickness at least equivalent to the adjacent *floor joists*, except *header joist* for *spans* greater than 8 feet (2.44 m) shall be determined in accordance with Tables D7-1 through D7-4. *Track* sections shall be the same thickness as the *C-shape* listed in the tables. Each *track* section for built-up *header* or trimmer *joist* shall extend the full length of the *joist* (continuous). Each *header joist* shall be connected to trimmer joists with four 2-inch x 2-inch (51 mm x 51 mm) *clip angles*. Each *clip angle* shall be fastened to both the *header* and trimmer joists with four No. 8 screws evenly spaced through each leg of the *clip angle*. The *clip angles* shall have a thickness not less than that of the *floor joist*.

In floor assemblies supported by wall framing with openings greater than 6 ft (1.83 m), the built-up trimmer *joist* shall be supported by a pair of wall *studs* beneath.

D8 Floor Trusses

Cold-formed steel floor trusses shall be designed, braced, and installed in accordance with Chapter E of AISI S240. *Truss* members shall not be notched, cut, or altered in any manner without an *approved* design.

D9 Diaphragms

A floor *diaphragm* shall be provided by attaching a minimum of 19/32-inch (15.1 mm) wood structural panel, which complies with DOC PS 1, DOC PS 2, CSA O437, or CSA O325 to *floor joists* in accordance with Table D2-2. Screws used to attach the floor *diaphragm* shall have minimum head diameter of 0.29 inch (7 mm).

D9.1 Floor Diaphragms in High Seismic Areas and High Wind Areas

In *high seismic areas* and *high wind areas*, floor *diaphragms* shall be constructed in accordance with Section D9 except that the screw spacing shall be 6 inches (152 mm) on panel edges and in the field. The *diaphragms* are permitted to be unblocked, and are permitted to be constructed in any panel configuration.

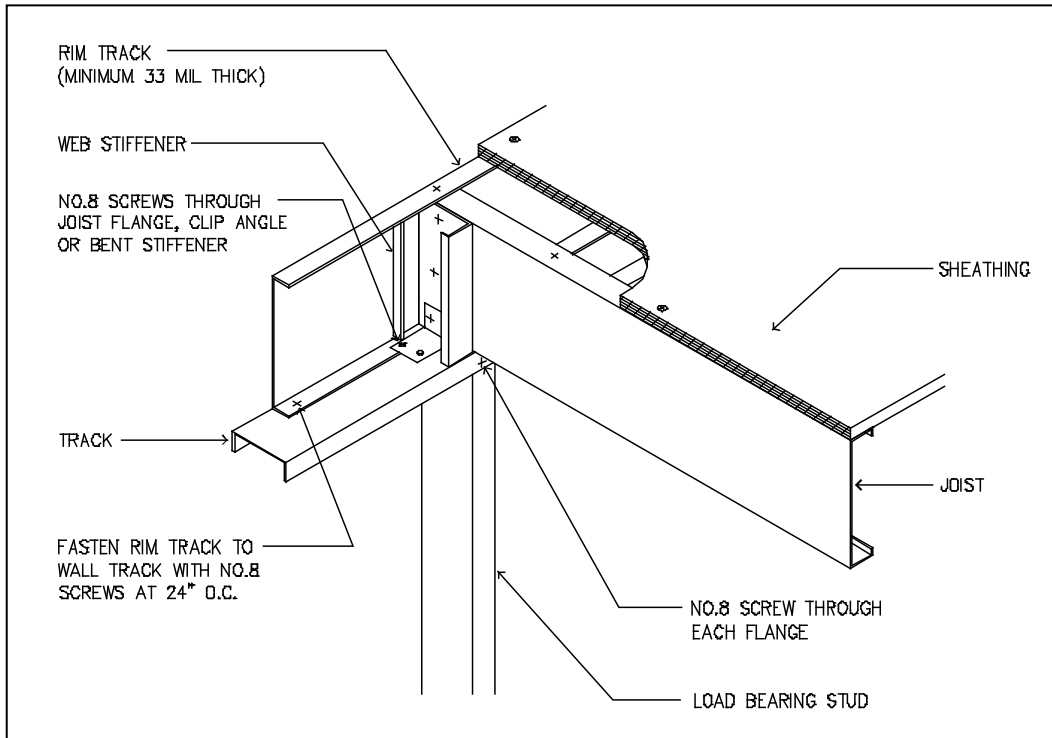

Figure D2-1 Floor to Exterior Structural Wall Connection

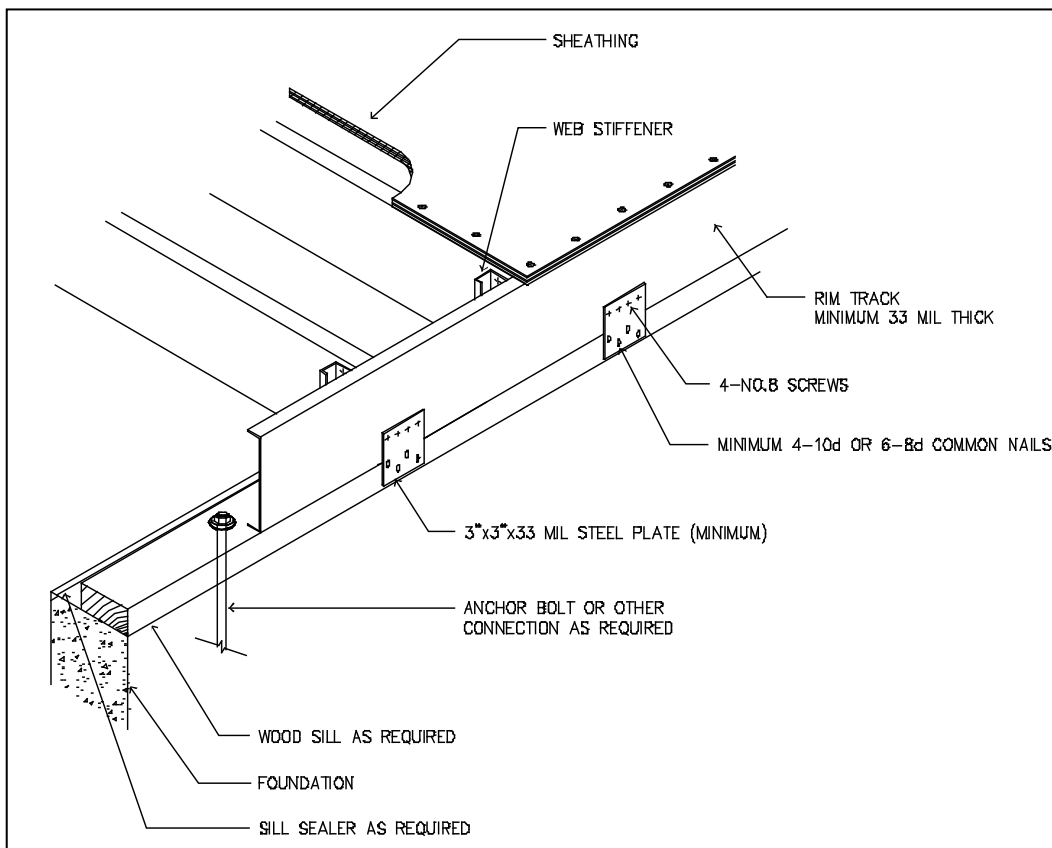

Figure D2-2 Floor to Wood Sill Connection

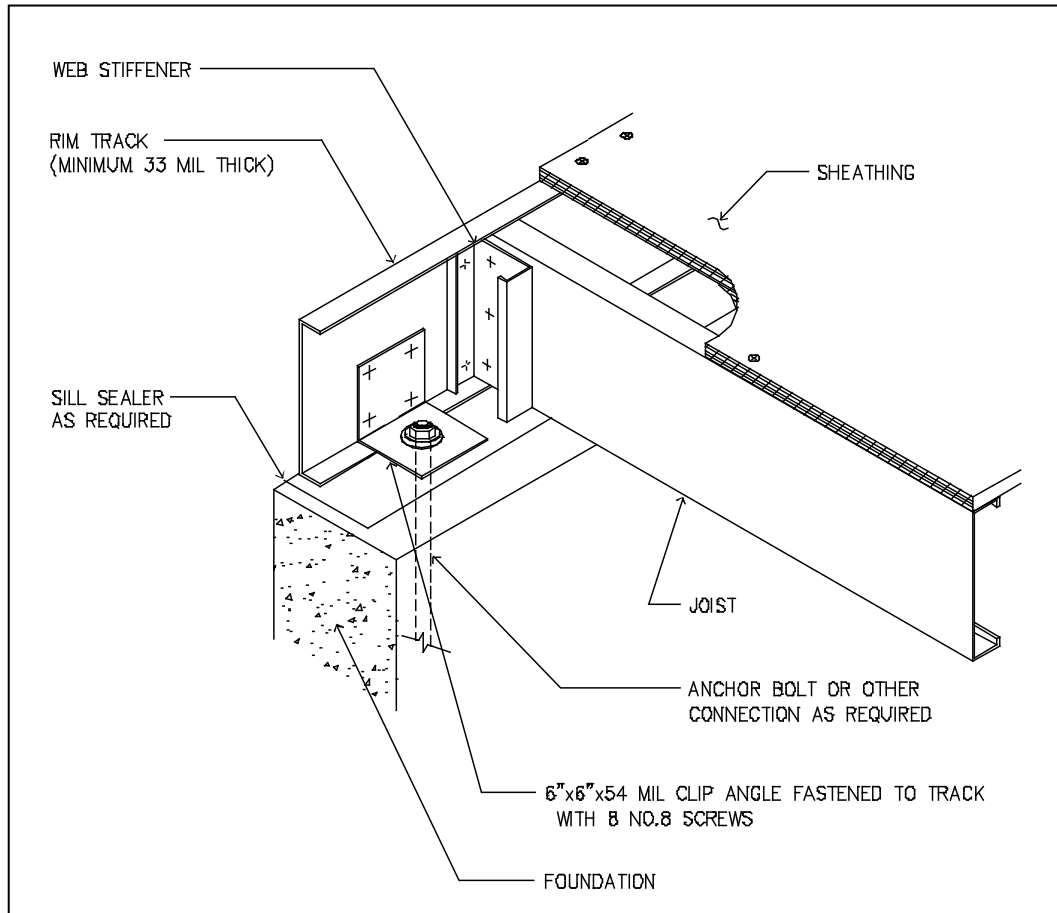

Figure D2-3 Floor to Foundation Connection

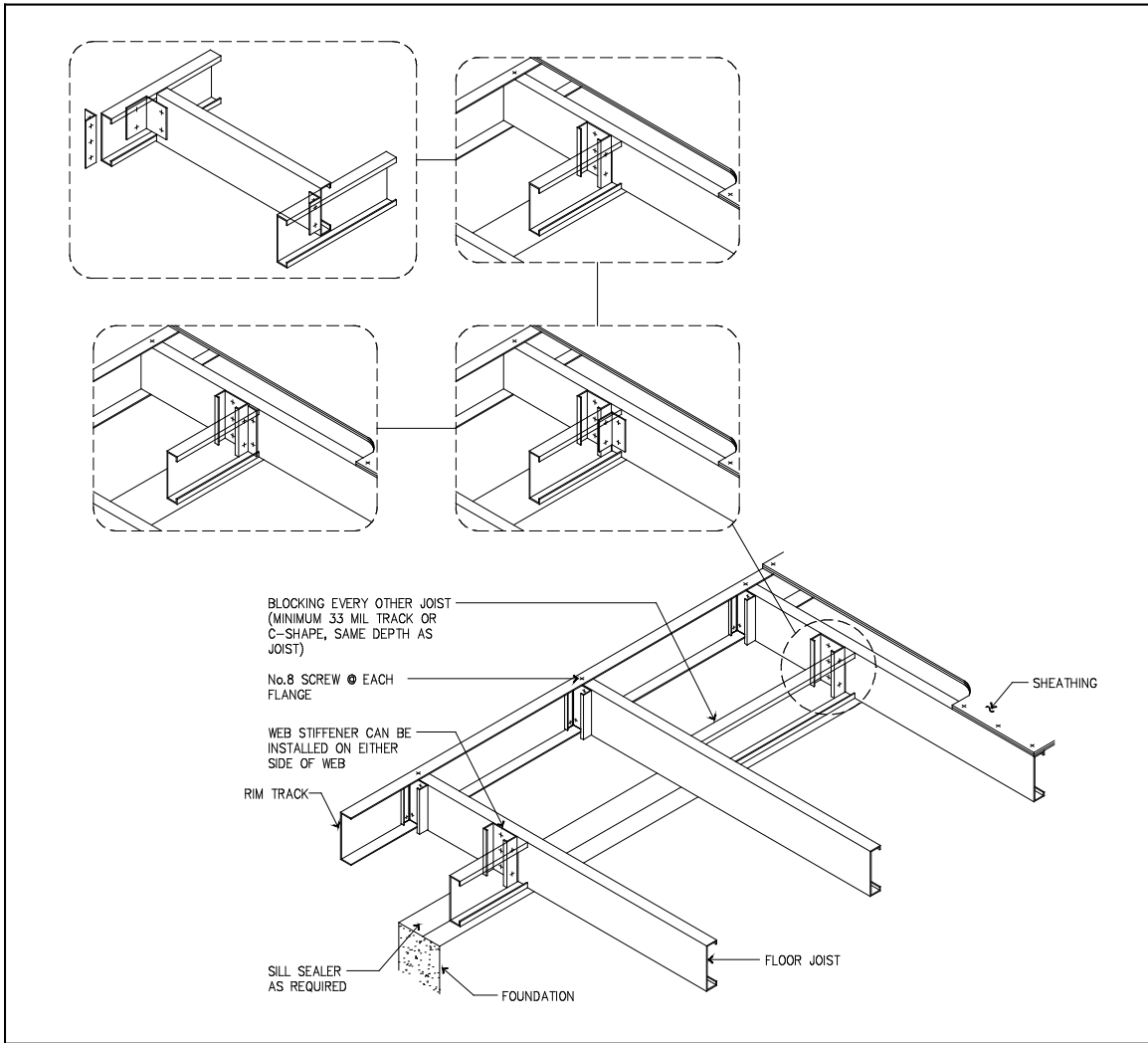

Figure D2-4 Cantilevered Floor to Foundation Connection

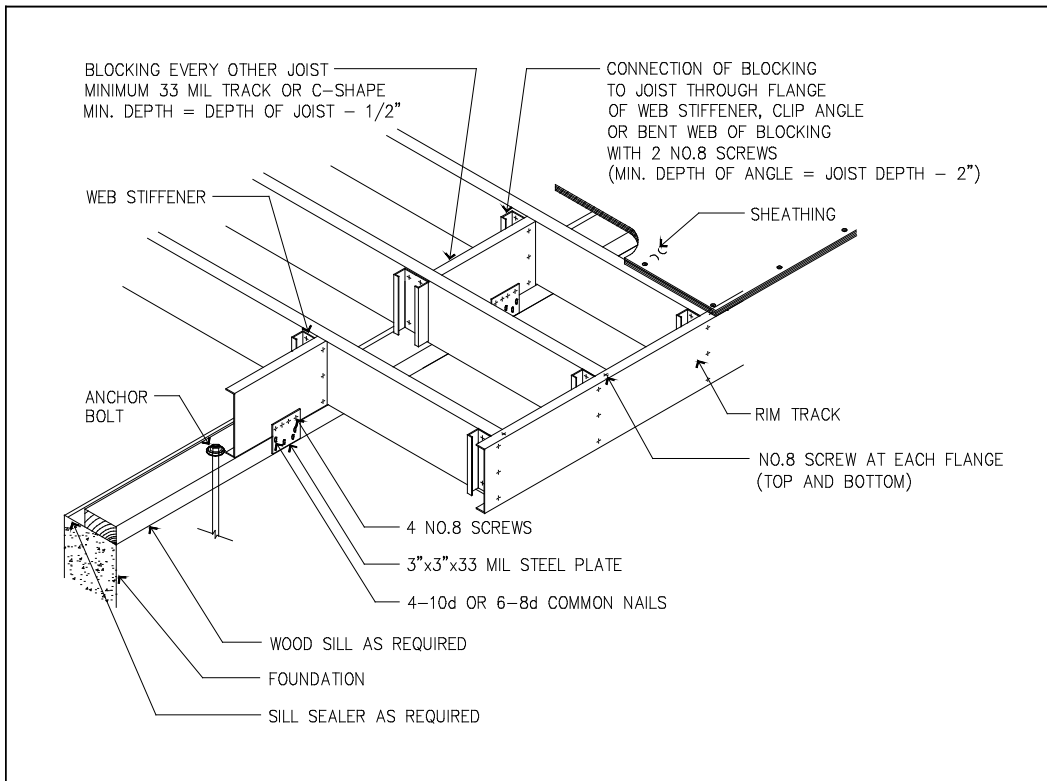

Figure D2-5 Cantilevered Floor to Wood Sill Connection

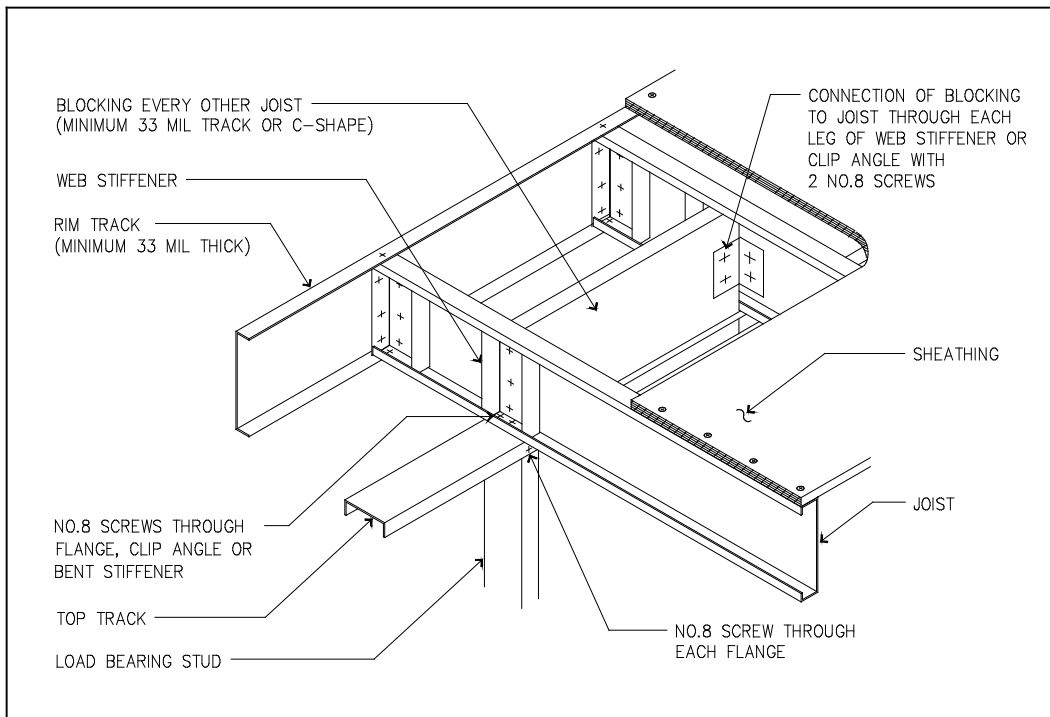

Figure D2-6 Cantilevered Floor to Exterior Structural Wall Connection

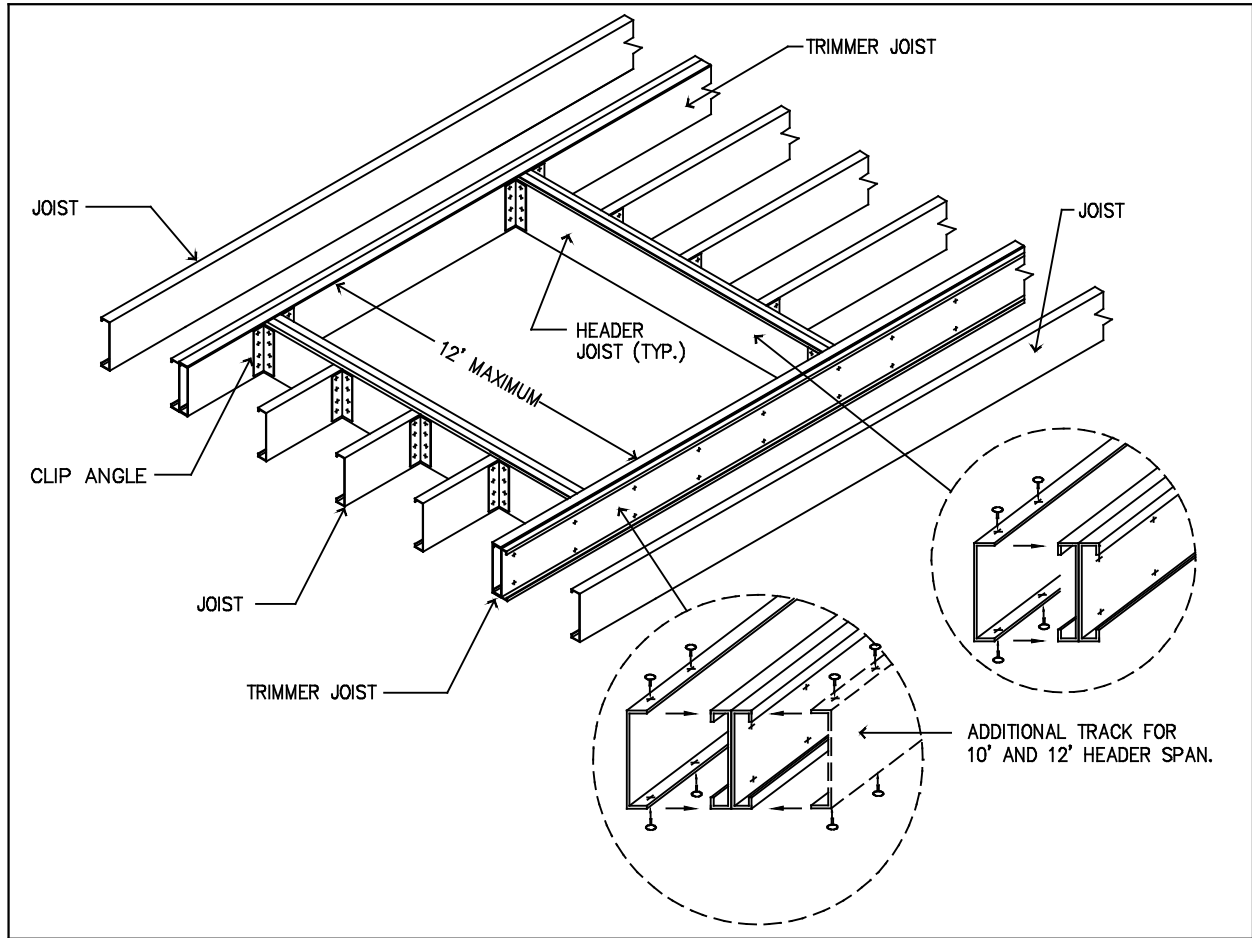

Figure D2-7 Continuous Span Joist Supported on an Interior Structural Wall

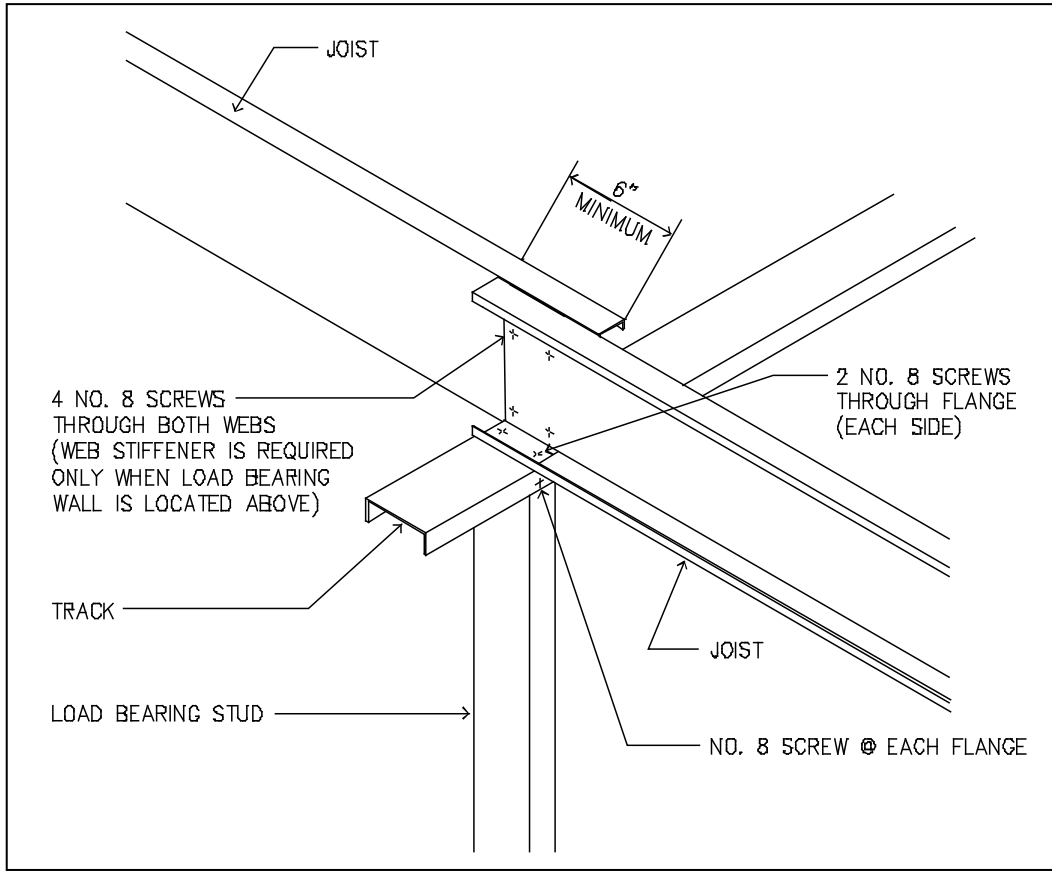

Figure D2-8 Lapped Joist Supported on Interior Structural Wall

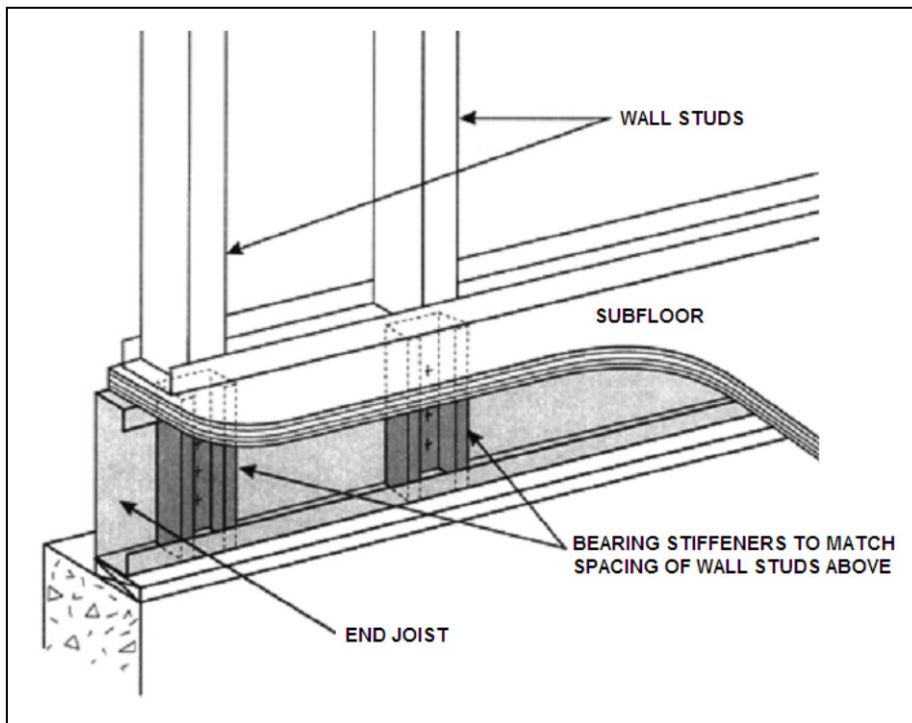

Figure D2-9 Bearing Stiffeners for End Joist

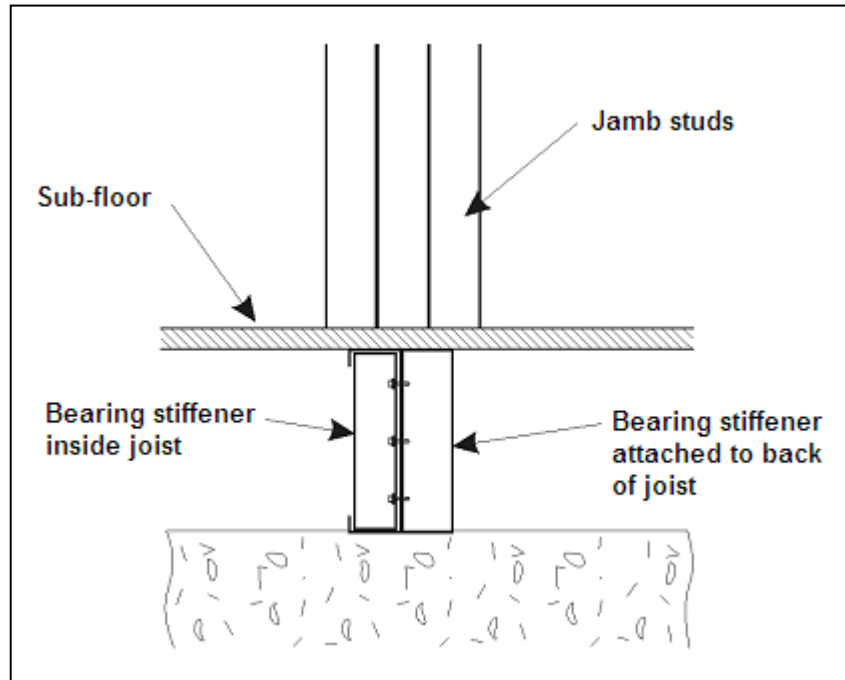

Figure D4-1 Bearing Stiffeners Under Jamb Studs

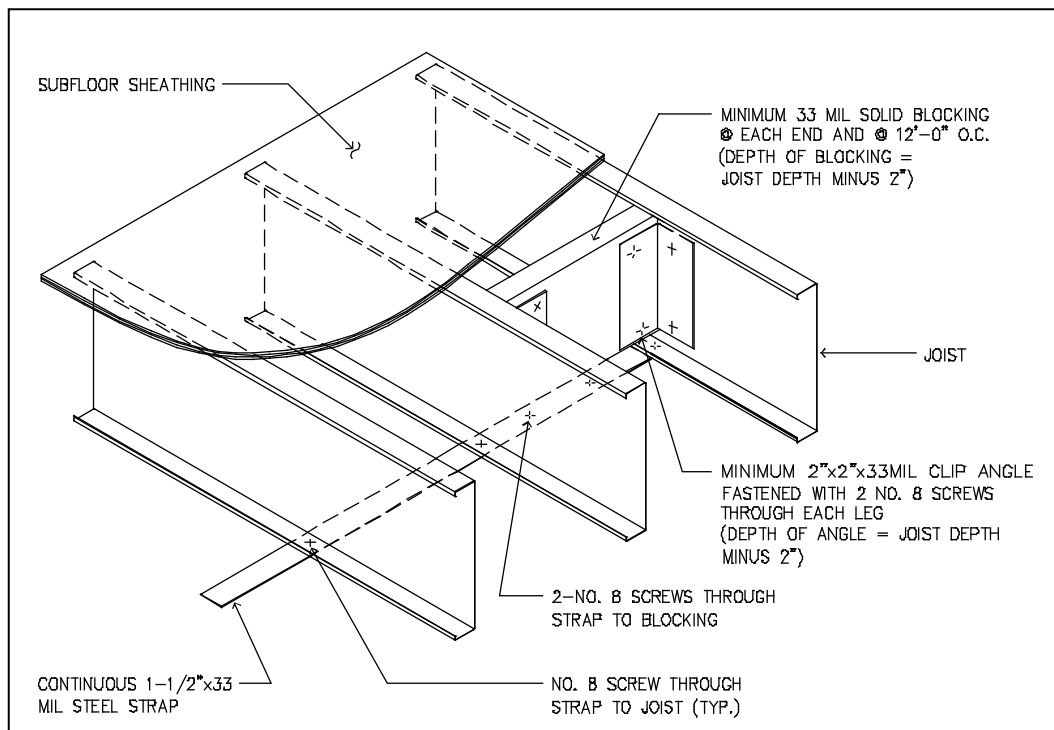

Figure D5-1 Joist Blocking (Solid)

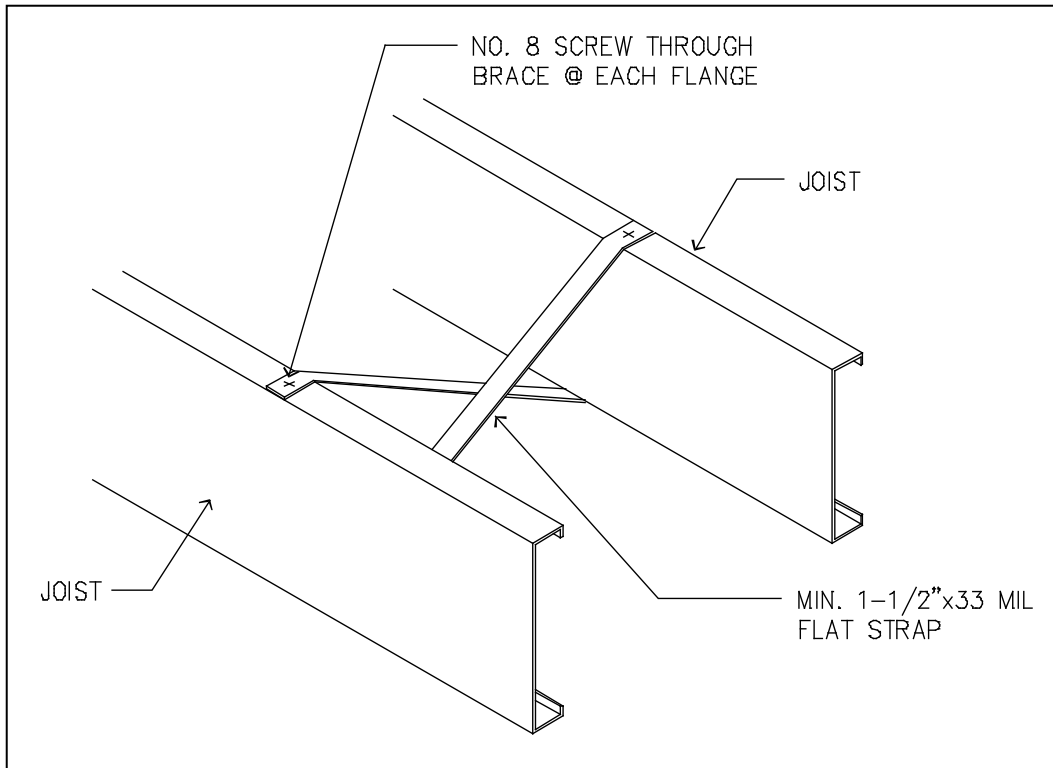

Figure D5-2 Joist Blocking (Strap)

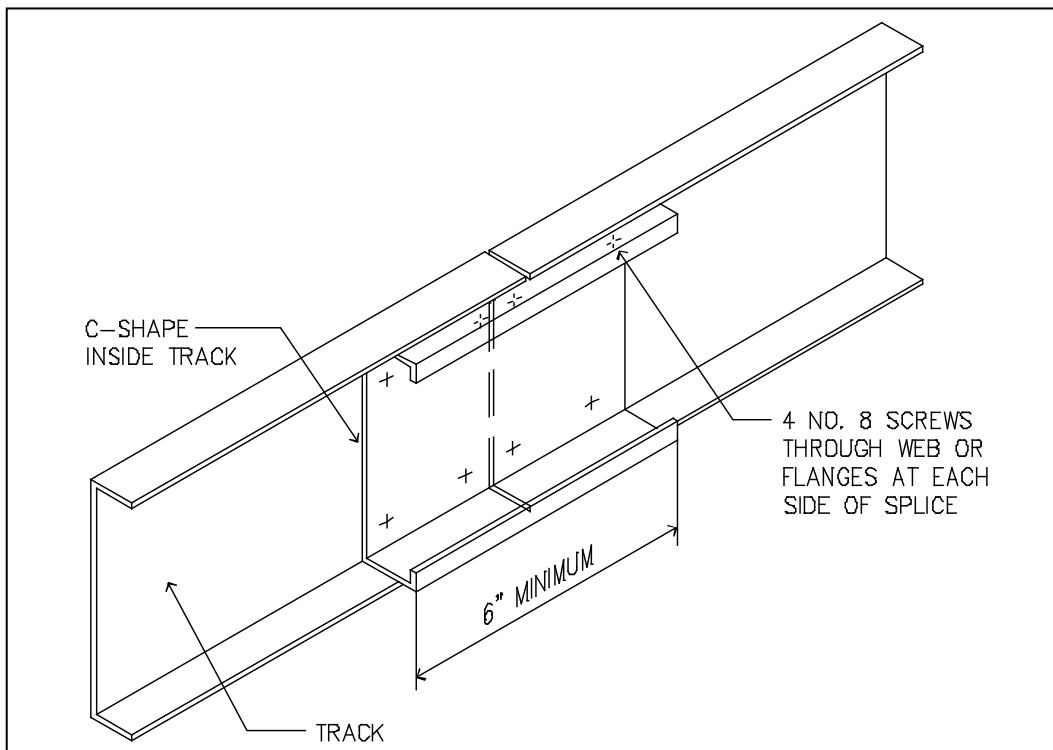

Figure D6-1 Track Splice

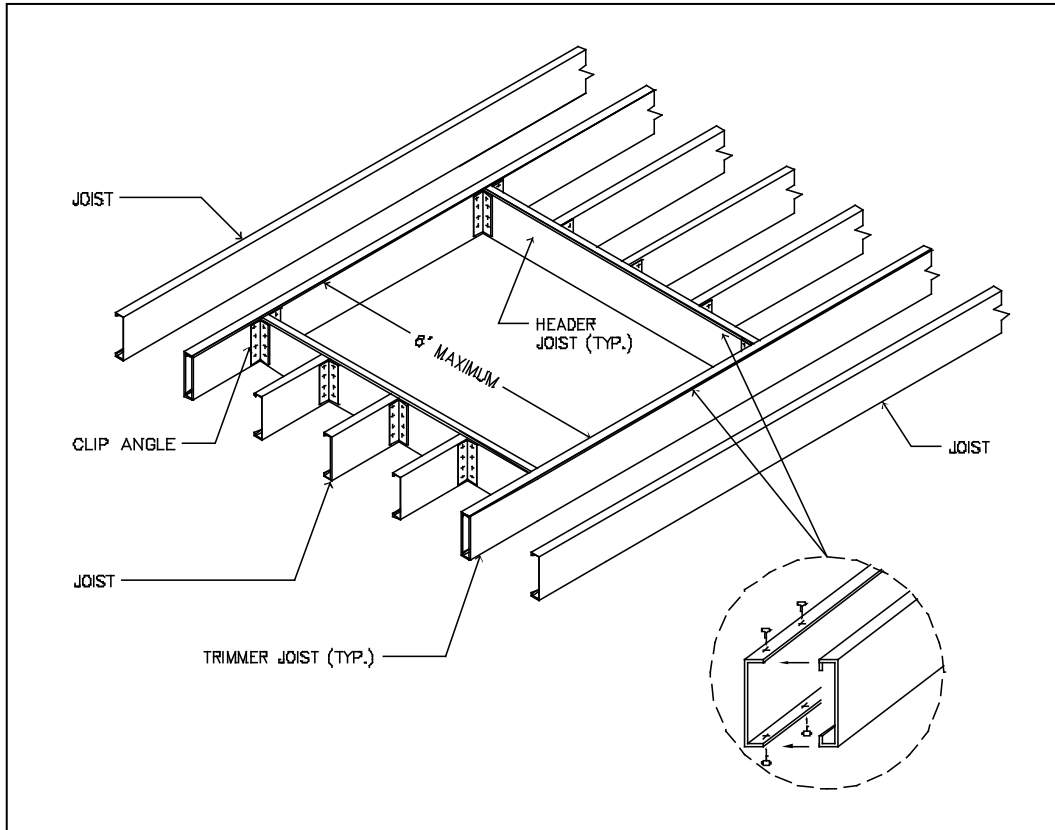

Figure D7-1 Six-Foot Floor Opening

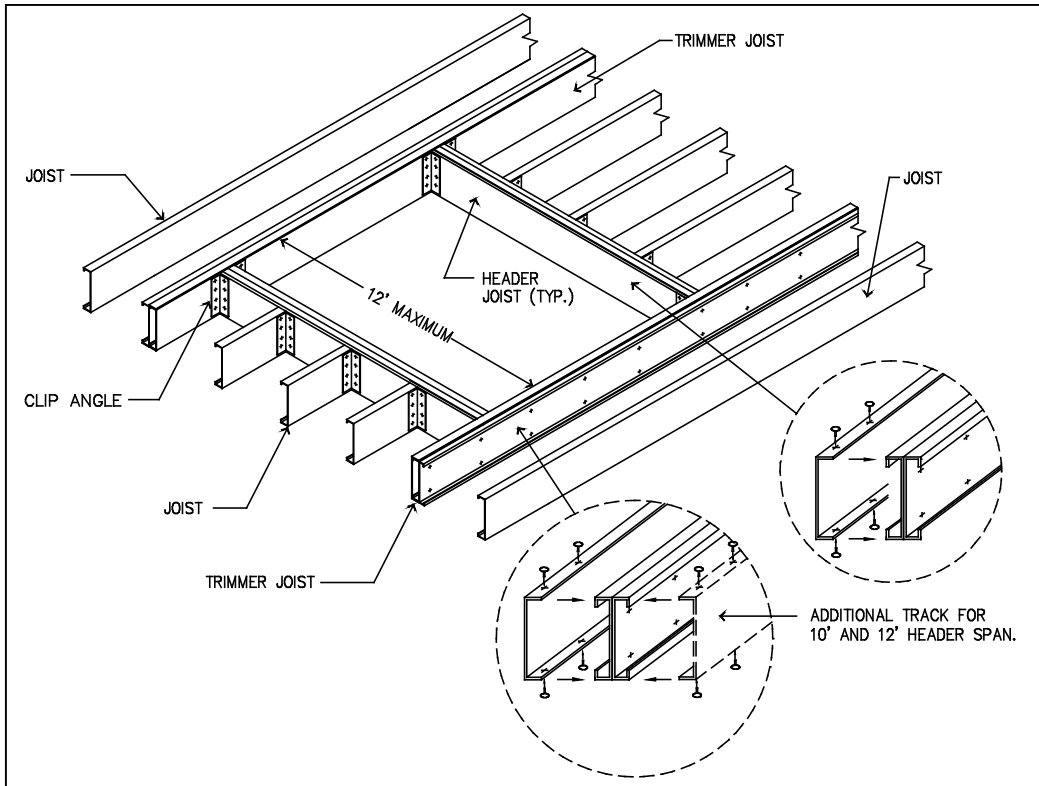

Figure D7-2 Twelve-Foot Floor Opening (Eight-Foot and Ten-Foot Similar)

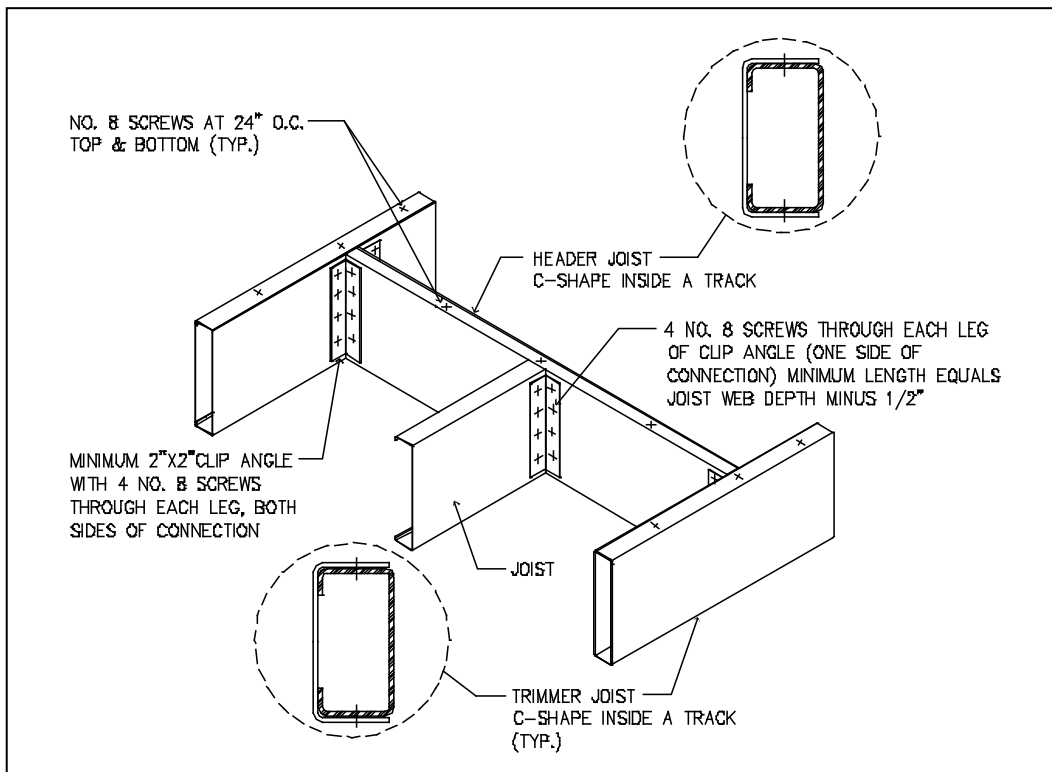

Figure D7-3 Floor Header to Trimmer Connection—Six-Foot Opening

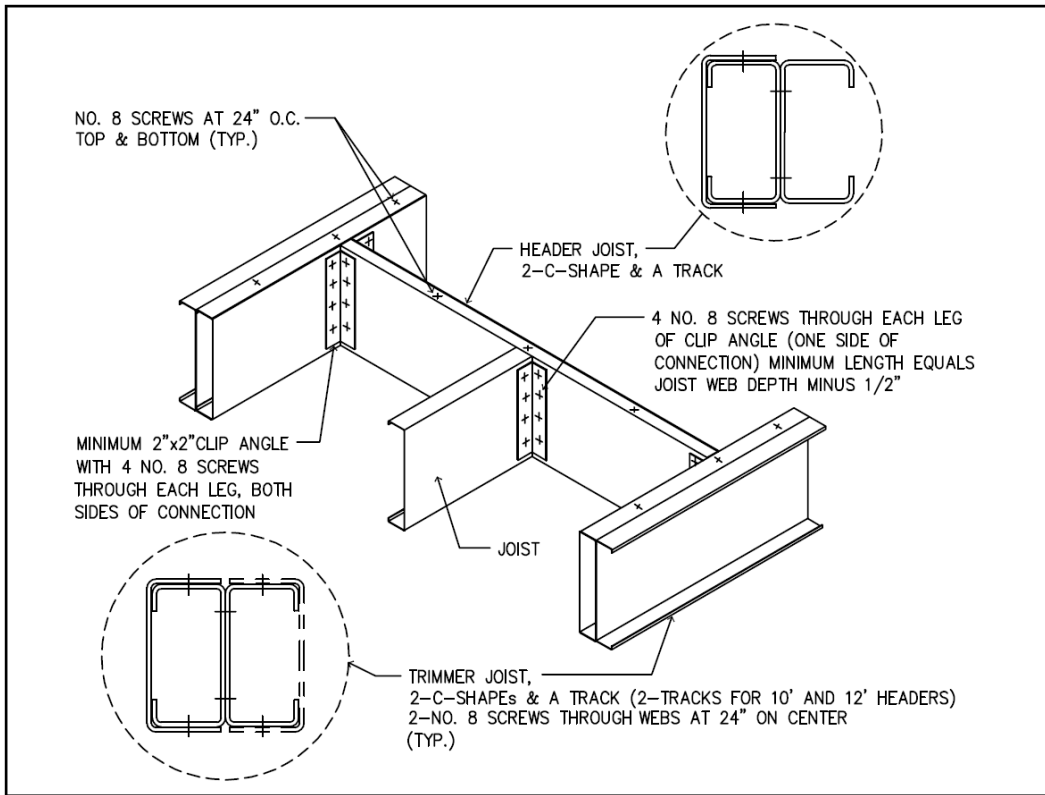

Figure D7-4 Floor Header to Trimmer Connection—Twelve-Foot Opening (Eight-Foot and Ten-Foot Openings Similar)

Table D2-1
Floor to Foundation or Structural Wall Connection Requirements ^{1, 2}

Framing Condition	Basic Wind Speed (mph), Exposure, and Seismic Design Category ³	
	115 MPH Exposure C or Less Than 140 MPH Exposure B— Seismic Design Categories A, B & C	Less Than 140 MPH Exposure C
<i>Floor joist to wall track of exterior wall per Figure D2-1</i>	2-No. 8 screws	3-No. 8 screws
<i>Rim track or end joist to structural wall top track per Figure D2-1</i>	1-No. 8 screw at 24" o.c.	1-No. 8 screw at 24" o.c.
<i>Rim track or end joist to wood sill per Figure D2-2</i>	Steel plate spaced at 4' o.c. with 4-No. 8 screws and 4 - 10d or 6 - 8d common nails	Steel plate spaced at 2' o.c. with 4-No. 8 screws and 4 - 10d or 6-8d common nails
<i>Rim track or end joist to foundation per Figure D2-3</i>	1/2" minimum diameter anchor bolt and <i>clip angle</i> spaced at 6' o.c. with 8-No. 8 screws	1/2" minimum diameter anchor bolt and <i>clip angle</i> spaced at 4' o.c. with 8-No. 8 screws
<i>Cantilevered joist to foundation per Figure D2-4</i>	1/2" minimum diameter anchor bolt and <i>clip angle</i> spaced at 6' o.c. with 8-No. 8 screws	1/2" minimum diameter anchor bolt and <i>clip angle</i> spaced at 4' o.c. with 8-No. 8 screws
<i>Cantilevered joist to wood sill per Figure D2-5</i>	Steel plate spaced at 4' o.c. with 4 - screws and 4 - 10d or 6 - 8d common nails	Steel plate spaced at 2' o.c. with 4-No. 8 screws and 4 - 10d or 6-8d common nails
<i>Cantilevered joist to wall track per Figure D2-6</i>	2-No. 8 screws	3-No. 8 screws

For SI: 1 inch = 25.4 mm, 1 psf = 0.0479 kN/m², 1 mph = 1.61 km/hr, 1 foot = 0.305 m

¹ Use the highest of the wind speed and exposure or the seismic requirements for a given site.

² Anchor bolts are to be located not more than 12 inches (305 mm) from corners or the termination of bottom tracks (e.g. at door openings or corners).

³ See Sections E11 through E13 for floor connection requirements in *high seismic areas* and *high wind areas*.

Table D2-2
Floor Fastening Schedule

Description of Building Elements	Number and Size of Fasteners	Spacing of Fasteners
<i>Floor joist to track of an interior structural wall in accordance with Figures D2-7 and D2-8</i>	2-No. 8 screws	Each <i>joist</i>
<i>Floor joist to rim track at end of joist</i>	2-No. 8 screws	One per <i>flange</i> or two per <i>bearing stiffener</i>
Subfloor sheathing to <i>floor joists</i>	No. 8 screws ¹	6 inches on center on edges and 12 inches on center at intermediate supports ²

For SI: 1 inch = 25.4 mm

¹ Screws to attach subfloor sheathing to *floor joists* are to have minimum head diameter of 0.29 inch (7 mm).

² Fastener spacing on intermediate supports is 6 inches o.c. for *high seismic areas* and *high wind areas* per Section D9.1.

Table D3-1
Floor Joists – Single Spans ^{1,2,3,4,5,6,7}

Joist Designation	30 psf Live Load				40 psf Live Load			
	Spacing (inches)				Spacing (inches)			
	12	16	19.2	24	12	16	19.2	24
550S162-33	11'-8"	10'-4"	9'-5"	8'-5"	10'-7"	9'-2"	8'-5"	7'-6"
550S162-43	12'-8"	11'-6"	10'-8"	10'-5"	11'-6"	10'-4"	9'-10"	9'-3"
550S162-54	13'-7"	12'-4"	11'-7"	10'-9"	12'-4"	11'-3"	10'-7"	9'-10"
550S162-68	14'-7"	13'-3"	12'-6"	11'-7"	13'-3"	12'-0"	11'-4"	10'-6"
550S162-97	16'-2"	14'-8"	13'-10"	12'-10"	14'-8"	13'-4"	12'-6"	11'-8"
800S162-33	14'-6"	12'-6"	11'-5"	10'-3"	12'-10"	11'-1"	10'-2"	9'-1"
800S162-43	17'-0"	15'-1"	13'-9"	12'-4"	15'-5"	13'-5"	12'-3"	10'-11"
800S162-54	18'-3"	16'-7"	15'-8"	14'-6"	16'-7"	15'-1"	14'-2"	13'-2"
800S162-68	19'-9"	17'-11"	16'-11"	15'-8"	17'-11"	16'-3"	15'-4"	14'-3"
800S162-97	21'-11"	19'-11"	18'-9"	17'-5"	19'-11"	18'-1"	17'-0"	15'-10"
1000S162-43	19'-4"	16'-9"	15'-3"	13'-8"	17'-2"	14'-10"	13'-7"	12'-2"
1000S162-54	21'-9"	19'-9"	18'-7"	17'-3"	19'-9"	18'-0"	16'-11"	15'-8"
1000S162-68	23'-7"	21'-5"	20'-2"	18'-9"	21'-5"	19'-6"	18'-4"	17'-0"
1000S162-97	26'-5"	24'-0"	22'-7"	21'-0"	24'-0"	21'-10"	20'-6"	19'-1"
1200S162-54	25'-1"	22'-10"	21'-6"	19'-9"	22'-10"	20'-9"	19'-6"	17'-6"
1200S162-68	27'-3"	24'-9"	23'-4"	21'-8"	24'-9"	22'-6"	21'-2"	19'-8"
1200S162-97	30'-10"	28'-0"	26'-4"	24'-5"	28'-0"	25'-5"	23'-11"	22'-3"

For SI: 1 inch = 25.4 mm, 1 psf = 0.0479 kN/m², 1 foot = 0.305 m

¹ Table provides the maximum clear span in feet and inches.

² *Bearing stiffeners* are to be installed at all support points and concentrated loads.

³ Deflection criteria: L/480 for live loads, L/240 for total loads.

⁴ Floor dead load = 10 psf (0.479 kN/m²)

⁵ The minimum *yield strength*, F_y , of *cold-formed steel* framing members is 50 ksi (340 MPa) for members with a *designation thickness* equal to or greater than 54 mils.

⁶ Table D3-1 is not applicable for 800S162-33 and 1000S162-43 continuous *joist* members.

⁷ The 12-inch (305 mm) and 19.2-inch (488 mm) framing spacing provide options for design, but do not negate the *in-line framing* requirement of Section E.

Table D7-1
Built-Up Header Size for 10-Foot Floor Opening ^{1,2,3}

Joist Designation	30 psf Live Load			
	Spacing (inches)			
	12	16	19.2	24
1000S162-43	1000S162-54	1000S200-43	1000S162-43	1000S162-43
1000S162-54	1000S162-54	1000S162-54	1000S200-43	1000S162-54
1000S162-68	1000S162-54	1000S162-54	1000S162-54	1000S200-54
1000S162-97	1000S162-54	1000S162-54	1000S162-54	1000S162-54
1200S162-43	1200S162-54	1200S162-54	1200S162-54	1200S162-54
1200S162-54	1200S162-54	1200S162-54	1200S162-54	1200S162-54
1200S162-68	1200S162-54	1200S162-54	1200S162-54	1200S162-54
1200S162-97	1200S162-68	1200S162-54	1200S162-54	1200S162-54

For SI: 1 inch = 25.4 mm, 1 psf = 0.0479 kN/m², 1 foot = 0.305 m

¹ Deflection criteria: L/480 for live loads, L/240 for total loads

² Floor dead load = 10 psf (0.479 kN/m²)

³ The minimum yield strength, F_y , of cold-formed steel framing members is 50 ksi (340 MPa) for members with a designation thickness equal to or greater than 54 mils.

Table D7-2
Built-Up Header Size for 10-Foot Floor Opening ^{1,2,3}

Joist Designation	40 psf Live Load			
	Spacing (inches)			
	12	16	19.2	24
1000S162-43	1000S162-54	1000S162-54	1000S200-43	1000S162-43
1000S162-54	1000S162-54	1000S162-54	1000S162-54	1000S200-43
1000S162-68	1000S162-54	1000S162-54	1000S162-54	1000S162-54
1000S162-97	1000S162-54	1000S162-54	1000S162-54	1000S162-54
1200S162-43	1200S162-54	1200S162-54	1200S162-54	1200S162-54
1200S162-54	1200S162-54	1200S162-54	1200S162-54	1200S162-54
1200S162-68	1200S162-68	1200S162-54	1200S162-54	1200S162-54
1200S162-97	1200S162-68	1200S162-68	1200S162-54	1200S162-54

For SI: 1 inch = 25.4 mm, 1 psf = 0.0479 kN/m², 1 foot = 0.305 m

¹ Deflection criteria: L/480 for live loads, L/240 for total loads

² Floor dead load = 10 psf (0.479 kN/m²)

³ The minimum yield strength, F_y , of cold-formed steel framing members is 50 ksi (340 MPa) for members with a designation thickness equal to or greater than 54 mils.

Table D7-3
Built-Up Header Size for 12-Foot Floor Opening ^{1,2,3}

Joist Designation	30 psf Live Load			
	Spacing (inches)			
	12	16	19.2	24
1000S162-43	1000S162-54	1000S162-54	1000S162-54	1000S162-54
1000S162-54	1000S200-54	1000S162-54	1000S162-54	1000S162-54
1000S162-68	1000S200-54	1000S162-54	1000S162-54	1000S162-54
1000S162-97	1000S162-68	1000S200-54	1000S200-54	1000S162-54
1200S162-43	1200S162-54	1200S162-54	1200S162-54	1200S162-54
1200S162-54	1200S200-54	1200S162-54	1200S162-54	1200S162-54
1200S162-68	1200S162-68	1200S200-54	1200S162-54	1200S162-54
1200S162-97	1200S162-68	1200S162-68	1200S162-68	1200S162-54

For SI: 1 inch = 25.4 mm, 1 psf = 0.0479 kN/m², 1 foot = 0.305 m

¹ Deflection criteria: L/480 for live loads, L/240 for total loads

² Floor dead load = 10 psf (0.479 kN/m²)

³ The minimum yield strength, F_y , of cold-formed steel framing members is 50 ksi (340 MPa) for members with a designation thickness equal to or greater than 54 mils.

Table D7-4
Built-Up Header Size for 12-Foot Floor Opening ^{1,2,3}

Joist Designation	40 psf Live Load			
	Spacing (inches)			
	12	16	19.2	24
1000S162-43	1000S200-54	1000S162-54	1000S162-54	1000S162-54
1000S162-54	1000S200-54	1000S200-54	1000S162-54	1000S162-54
1000S162-68	1000S162-68	1000S200-54	1000S200-54	1000S162-54
1000S162-97	1000S200-68	1000S162-68	1000S162-68	1000S200-54
1200S162-43	1200S162-68	1200S162-54	1200S162-54	1200S162-54
1200S162-54	1200S162-68	1200S200-54	1200S162-54	1200S162-54
1200S162-68	1200S162-68	1200S162-68	1200S162-68	1200S200-54
1200S162-97	1200S200-68	1200S162-68	1200S162-68	1200S162-68

For SI: 1 inch = 25.4 mm, 1 psf = 0.0479 kN/m², 1 foot = 0.305 m

¹ Deflection criteria: L/480 for live loads, L/240 for total loads

² Floor dead load = 10 psf (0.479 kN/m²)

³ The minimum yield strength, F_y , of cold-formed steel framing members is 50 ksi (340 MPa) for members with a designation thickness equal to or greater than 54 mils.

E. WALL FRAMING

E1 Wall Construction

Structural walls shall be constructed in accordance with the provisions of this section. Non-structural walls shall be constructed in accordance with AISI S220 and shall have a minimum *base metal thickness* of 18 mils (0.45 mm).

E2 Wall to Foundation or Floor Connection

Structural walls shall be anchored to foundations or floors in accordance with Table E2-1 and Figures E2-1 through E2-4. Gable end walls with *stud* heights greater than 10 feet (3.05 m) shall be anchored to foundations or floors in accordance with Tables E2-2 and E2-3. In *high seismic areas* and *high wind areas*, the anchorage of structural walls to foundations and floors shall be in accordance with the provisions of Sections E11, E12 and E13 as applicable.

Anchor bolts shall be located not more than 12 inches (305 mm) from corners or the termination of bottom *tracks*. Anchor bolts shall extend a minimum of 15 inches (381 mm) into masonry or 7 inches (178 mm) into concrete. Foundation anchor straps are permitted, in lieu of anchor bolts, if spaced as required to provide equivalent anchorage to the required anchor bolts and installed in accordance with the manufacturer's requirements. Anchorage requirements shall also be determined in the foundation design in accordance with Section C1.

E2.1 Uplift Connection In High Wind Areas - Wall Assembly to Foundation or Floor Assembly

In *high wind areas*, exterior wall *studs* in bottom story walls shall be attached to a wood sill plate or directly attached to the foundation by connections capable of resisting the uplift loads listed in Table E2-4. Alternatively, a continuous 1-1/4 inch (32 mm) by 33 mil (0.84 mm) steel uplift *strap* is permitted when placed under the wood sill and attached to both *flanges* of the exterior *stud* as shown in Figure E2-5. The uplift *strap* shall be fastened to each *flange* with minimum No. 8 screws as required by Table E2-5.

E3 Minimum Stud Sizes

Structural walls shall be constructed in accordance with Figures E2-1, E2-2, E2-3 and E2-4, as applicable. The alternate wall to foundation connection shown in Figure E2-2 is permitted only where the center line of the anchor bolt or other connection, as required, is located not greater than 3 inches from the *stud*. Exterior wall *stud* size and thickness shall be determined in accordance with the limits set forth in Tables E3-1 through E3-15. The size and thickness of gable endwall *studs* with heights less than or equal to 10 feet (3.05 m) are permitted to be determined in accordance with the limits set forth in Table E3-16. The size and thickness of gable endwall *studs* with heights greater than 10 feet (2.94 m) shall be determined in accordance with the limits set forth in Table E3-17. Interior structural wall *stud* size and thickness shall be determined in accordance with the limits set forth in Tables E3-1 through E3-15 based upon a 115 mph (185 km/hr) Exposure B wind value and the building width, *stud* spacing and snow load as appropriate. Fastening requirements shall be in accordance with Section B and Table E3-18. Top and bottom *tracks* shall have the same minimum thickness as the wall *studs*.

Exterior 43 mil Grade 33 wall *studs* are permitted to be reduced to the next thinner size, as shown in Tables E3-1 through E3-15, when both of the following conditions exist:

- (1) Minimum of 1/2 inch (13 mm) gypsum board is installed and fastened in accordance with Table E3-18 on the interior surface.
- (2) Wood *structural sheathing* panels of minimum 7/16 inch (11 mm) thick oriented strand board or 15/32 inch (12 mm) thick plywood is installed and fastened in accordance with

Section E8.2 on the outside surface.

Interior 43 mil Grade 33 structural wall *studs* are permitted to be reduced to the next thinner size, as shown in Tables E3-1 through E3-15, when a minimum of 1/2 inch (13 mm) gypsum board is installed and fastened in accordance with Table E3-18 on both sides of the wall.

The tabulated *stud* thickness for structural walls shall be used when the attic load is 10 psf (0.48 kN/m²) or less. A *limited attic storage* load of 20 psf (0.96 kN/m²) is permitted provided that the next higher snow load column is used to select the *stud* size from Tables E3-1 through E3-15.

For two-story buildings, the tabulated *stud* thickness for walls supporting one floor, roof and ceiling shall be used when the second floor live load is 30 psf (1.44 kN/m²). Second floor live loads of 40 psf (1.92 kN/m²) are permitted provided that the next higher snow load column is used to select the *stud* size from Tables E3-6 through E3-10.

For three-story buildings, the tabulated *stud* thickness for walls supporting one or two floors, as applicable, roof and ceiling shall be used when the third floor live load is 30 psf (1.44 kN/m²). Third floor live loads of 40 psf (1.92 kN/m²) are permitted provided that the next higher snow load column is used to select the *stud* size from Tables E3-11 through E3-15.

E4 Stud Bracing

The *flanges* of structural *studs* shall be laterally braced in accordance with one of the following methods:

1. Gypsum board on both sides, *structural sheathing* on both sides, or gypsum board on one side and *structural sheathing* on the other side of structural walls fastened in accordance with Table E3-18 and Figure E4-1. Screws for attachment of *structural sheathing* panels shall be bugle-head, flat-head, or similar head style with a minimum head diameter of 0.29 inches (8 mm).
2. Horizontal steel *straps* fastened in accordance with Figure E4-2 on both sides at mid-height for 8-foot (2.44 m) walls, and at one-third points for 9- and 10-foot (2.74 and 3.05 m) walls. Horizontal steel *straps* shall be at least 1-1/2 inches in width and 33 mils in thickness (38 x 0.84 mm). *Straps* shall be attached to the *flanges* of *studs* with one No. 8 screw. In-line *blocking* shall be installed between *studs* at the termination of all *straps* and at 12-foot (3.66 m) intervals along the *strap*. *Straps* shall be fastened to the *blocking* with two No. 8 screws.
3. Sheathing on one side and *strapping* on the other side fastened in accordance with Figure E4-3. Sheathing shall be installed in accordance with Method 1 above. Steel *straps* shall be installed in accordance with Method 2 above.

E5 Splicing

Structural *studs* and *headers* shall not be spliced without an *approved* design. Splicing of *tracks* shall conform to Figure E5-1 or, if applicable, Figure E11-7.

E6 Corner Framing

In exterior walls, corner *studs* and the top *track* shall be installed in accordance with Figure E6-1. Other *approved* corner framing details are permitted.

E7 Headers

Headers shall be installed above wall openings in structural walls in accordance with Sections E7.1 through E7.4. *Headers* shall not be required for openings in non-structural walls.

E7.1 Box-Beam Headers

Box-beam *headers* shall be constructed in accordance with Figure E7-1 and Tables E7-1

through E7-6. *Header spans* for building widths between those tabulated are permitted to be determined by interpolation. *Headers* shall be constructed from two equal-sized *C-shaped* members in a box type configuration. *Headers* shall be connected to *king studs* in accordance with Table E7-13. One-half of the total number of required screws shall be applied to the *header* and one half to the *king stud* by use of *C-shaped* or *track* member in accordance with Figure E7-1. The *track* or *C-shape* sections shall extend the depth of the *header* minus 1/2 inch (13 mm) and shall have a minimum thickness not less than the wall *studs*.

Exceptions:

1. *Headers* in gable endwalls are permitted to be constructed with the header directly above the opening, as shown in Figure E7-3.
2. *Headers* in gable endwalls are permitted to be sized as follows:
 - (a) 362S162-33 for openings less than or equal to 4 feet (1.22 m)
 - (b) 600S162-43 for openings greater than 4 feet (1.22 m) but less than or equal to 6 feet (1.83 m)
 - (c) 800S162-54 for openings greater than 6 feet (1.83 m) but less than or equal to 9 feet (2.74 m)

E7.2 Back-to-Back Headers

Back-to-back *headers* shall be constructed in accordance with Figure E7-2 and Tables E7-7 through E7-12. *Header spans* for house widths between those tabulated are permitted to be determined by interpolation. *Headers* shall be formed from two equal-sized *C-shaped* members in a back-to-back configuration. *Headers* shall be connected to *king studs* in accordance with Table E7-13. One-half of the total number of screws shall be applied to the *header* and one-half to the *king stud* by use of a minimum 2 x 2 inch (51 x 51 mm) *clip angle* in accordance with Figure E7-2. The *clip angle* shall extend the depth of the *header* minus 1/2 inch (13 mm) and shall have a minimum thickness not less than the wall *studs*.

Exceptions:

1. *Headers* in gable endwalls are permitted to be constructed with the header directly above the opening, as shown in Figure E7-4.
2. *Headers* in gable endwalls are permitted to be sized as follows:
 - (a) 362S162-33 for openings less than or equal to 4 feet (1.22 m)
 - (b) 600S162-43 for openings greater than 4 feet (1.22 m) but less than or equal to 6 feet (1.83 m)
 - (c) 800S162-54 for openings greater than 6 feet (1.83 m) but less than or equal to 9 feet (2.74 m)

E7.3 L-Headers

An *L-header* shall consist of a *cold-formed steel* angle with one short leg lapping over the top *track* of the wall and one leg extending down the side of the wall above window or door openings, as shown in Figures E7-5 and E7-6. Each angle shall be fastened to top *track* above an opening with No. 8 screws spaced at 12 inches (305 mm) on center. The "L" angle shall be placed on both sides of the wall opening to form a double angle L-shaped *header* (double *L-header*). The long leg of the *L-header* angle shall be attached to each *cripple stud(s)* and a minimum of one *king stud* at each end with one No. 8 screw at top and bottom.

E7.3.1 Double L-Headers

Double *L-headers* shall be constructed in accordance with Figure E7-5 and Tables E7-14 through E7-19 for gravity loading and Tables E7-20 through E7-34 for uplift loading.

E7.3.2 Single L-Headers

Single *L-headers* shall be constructed in accordance with Figure E7-6 and Tables E7-35 through E7-40. Use of single *L-headers* shall be limited to the following applications:

1. Single *L-headers* supporting one floor, roof and ceiling, where the wind speed is less than or equal to 115 mph Exposure C.
2. Single *L-headers* supporting two floors, roof and ceiling, where the wind speed is less than or equal to 130 mph Exposure C.

E7.3.3 Inverted L-Header Assemblies

Inverted double *L-headers* shall be constructed in accordance with Tables E7-14 through E7-19 for gravity loading and Tables E7-41 through E7-55 for uplift loading.

Inverted single *L-headers* shall be constructed in accordance with Tables E7-35 through E7-40 for gravity loading and Tables E7-56 through E7-70 for uplift loading.

Inverted double or single *L-headers* shall be constructed in accordance with the following, as shown in Figure E7-7:

- (1) The horizontal leg of the inverted *L-header* shall be coped to permit the vertical leg to lap over at least one bearing *stud* at each end. The horizontal leg after coping shall be within ½ inch (12.7 mm) of the bearing *stud* at each end.
- (2) The horizontal leg of the inverted *L-header* shall be attached to the head *track* at each end and at 12 inches (304.8 mm) on center with minimum No. 8 screws.
- (3) The vertical leg of the inverted *L-header* shall be attached to at least one bearing *stud* at each end and each cripple *stud* with a minimum No. 8 screw top and bottom. The top screw in the vertical leg of the inverted *L-header* shall be located not more than 1 inch (25.4 mm) from the top edge of the vertical leg.

E7.4 Jack and King Studs

The number of jack and *king studs* installed on each side of a *header* shall comply with Table E7-71. *Jack*, *king*, and *cripple studs* shall be of the same dimension and thickness as the adjacent wall *studs*. *Jack* and *king studs* shall be interconnected with *structural sheathing* in accordance with Figures E7-1 and E7-2.

E7.5 Head and Sill Track

Head *track spans*, above door and window openings, and sill *track spans*, beneath window openings, shall not exceed those shown in Table E7-72. For openings less than 4 feet (1.22 m) in height that have both a head *track* and a sill *track*, the spans in Table E7-72 are permitted to be multiplied by 1.75. For openings less than or equal to 6 feet (1.83 m) in height that have both a head *track* and a sill *track*, the spans in Table E7-72 are permitted to be multiplied by a factor of 1.5.

E8 Wall Bracing

Exterior walls shall be braced to provide in-plane lateral resistance to wind and seismic loads with diagonal steel *straps* or *structural sheathing* in accordance with Sections E8.1 or E8.2.

E8.1 Strap Bracing (X-Brace)

Diagonal steel *straps* (or "X-braces") and their connections shall be designed and installed in accordance with an *approved* design.

E8.2 Structural Sheathing

Structural sheathing shall be installed on all sheathable exterior wall surfaces, including areas above and below openings, in accordance with Figure E8-1 and this section.

E8.2.1 Sheathing Materials

Structural sheathing panels shall consist of minimum 7/16-inch (11 mm) thick oriented strand board or 15/32-inch (12 mm)-thick plywood.

E8.2.2 Determination of Minimum Length of Full-Height Sheathing

The minimum length of full-height sheathing on each *braced wall line* shall be determined by multiplying the length of the *braced wall line* by the larger of the percentage for wind or seismic loads obtained from Tables E8-1, E8-2 and E8-3 and by the *plan aspect ratio* adjustment factors obtained from Tables E8-4 and E8-5 for wind and seismic, as applicable. The minimum length of full-height sheathing shall not be less than 20 percent of the *braced wall line* length.

To be considered full-height sheathing, *structural sheathing* shall extend from the bottom to the top of the wall without interruption by openings. Only sheathed, full-height wall sections, uninterrupted by openings, which are a minimum of 48 inches (1220 mm) wide, shall be counted toward meeting the minimum percentages in Tables E8-1, E8-2 and E8-3.

In addition, *structural sheathing* shall comply with all of the following requirements:

- (1) Be installed with the long dimension parallel to the *stud* framing (i.e., vertical orientation) and cover the full vertical height of wall from the bottom of the bottom *track* to the top of the top *track* of each story. It is permitted to install the long dimension perpendicular to the *stud* framing or to use shorter segments provided that the horizontal joint is blocked as described in Item 2 below.
- (2) Be blocked when the long dimension is installed perpendicular to the *stud* framing (i.e., horizontal orientation). *Blocking* shall be a minimum of 33 mil (0.84 mm) thickness. Each horizontal *structural sheathing* shall be fastened with No. 8 screws spaced at 6 inches (152 mm) on center to the *blocking* at the joint.
- (3) Be applied to each end (corners) of each of the exterior walls with a minimum 48-inch (1220-mm)-wide panel.

E8.2.2.1 The minimum percentage of full-height *structural sheathing* shall be multiplied by 1.10 for 9-foot (2.74-m)-high walls and multiplied by 1.20 for 10-foot (3.05-m)-high walls.

E8.2.2.2 For hip-roofed homes, the minimum percentage of full-height sheathing in Table E8-1, based upon wind, is permitted to be multiplied by a factor of 0.95 for roof slopes not exceeding 7:12 and a factor of 0.9 for roof slopes greater than 7:12.

E8.2.2.3 In the lowest story of a dwelling, the percent of full-height sheathing required in Table E8-1 is permitted to be multiplied by 0.6, provided *hold-down* anchors are provided in accordance with Section 8.2.4.2.

E8.2.3 Structural Sheathing Fastening

All edges and interior areas of *structural sheathing* panels shall be fastened to framing members and *tracks* in accordance with Figure E8-1 and Table E3-18. Screws for attachment of *structural sheathing* panels shall be bugle-head, flat-head, or similar head style with a minimum head diameter of 0.29 inches (8 mm).

For continuously-sheathed *braced wall lines* using wood structural panels installed with No. 8 screws spaced 4-inch (102-mm) on center at all panel edges and 12-inch (305 mm) on center on intermediate framing members, the following shall apply:

- (1) The percentages of full-height sheathing, in Tables E8-1, E8-2 and E8-3, are permitted to be multiplied by 0.72.
- (2) For bottom *track* attached to foundations or framing below, the bottom *track* anchor or screw connection spacing in Table D2-1 and Table E2-1 shall be multiplied by 2/3.

E8.2.4 Uplift Connection Requirements

Uplift connections shall be provided in accordance with this section.

E8.2.4.1 Where wind speeds are in excess of 130 mph (209 km/hr) Exposure C, walls shall be provided wind direct uplift connections in accordance with Section E13.3 and Section F8.2, as required for 140 mph (225 km/hr) Exposure C.

E8.2.4.2 Where the percent of full-height sheathing is adjusted in accordance with Section E8.2.2.3, a *hold-down* anchor, with a strength of 4300 pounds (19.35 kN), shall be provided at each end of each full-height sheathed wall section used to meet the minimum percent sheathing requirements of Section E8.2.2. *Hold-down* anchors shall be attached to back-to-back studs; *structural sheathing* panels shall have edge fastening to the *studs*, in accordance with Section E8.2.3 and Table E11-1.

A single *hold-down* anchor installed in accordance with Figure E8-2 is permitted at the corners of buildings.

E9 Exterior Wall Covering

The method of attachment of exterior wall covering materials to *cold-formed steel stud* wall framing shall conform to the manufacturer's installation instructions.

E10 Reserved

This section has intentionally been left blank.

E11 Braced Walls in High Wind Areas and High Seismic Areas

E11.1 General

In *high wind areas* and in *high seismic areas*, *braced wall lines* shall be constructed in accordance with this section. In *high seismic areas*, buildings shall also be constructed in accordance with Section E12. In *high wind areas*, buildings shall also be designed in accordance with Section E13.

Where a building, or portion thereof, does not comply with the provisions of this section, those portions shall be designed and constructed in compliance with the building code, or with accepted engineering practice where no building code exists.

E11.2 Braced Wall Lines

Braced wall lines shall be composed of either *Type I* (solid) *braced wall panels* or *Type II* (perforated) *braced walls* as shown in Figure E11-1, and shall extend from the foundation to the roof *diaphragm* or floor *diaphragm* above.

Exception: The provisions of this Standard for *Type II* (perforated) *braced walls* shall not be applicable to the first floor of a 3-story structure in a *high wind area* or a *high seismic area*.

The required length of bracing shall be determined in accordance with the greater

requirement for seismic or wind loads. Each *braced wall line* shall have not less than two full-height braced wall panels, each having a maximum height-to-width aspect ratio of 2:1.

Braced wall panels shall begin not more than 8 feet (2.44 m) from each end of a braced wall.

Sheathing on *Type I* and *Type II braced walls* shall be wood *structural sheathing* panels or *steel sheets* on one side. Sheathing panels or *steel sheets* used as part of the braced wall panel shall be a minimum of 12 inches (305 mm) wide.

Where wood *structural sheathing* panels are used, they shall be 7/16-inch (11 mm) Rated Sheathing (OSB) or 15/32-inch (12 mm) Structural I Plywood Sheathing and shall be attached to framing members with minimum No. 8 screws spaced a maximum of 12 inches (305 mm) in the field and 6 inches (152 mm) on all edges, unless a lesser spacing is used in accordance with Section E11.3 to adjust the required shearwall length.

Where *steel sheets* are used, they shall be 27 mil (0.69 mm) thick and shall be attached to framing members with minimum No. 8 screws spaced a maximum of 12 inches (305 mm) in the field and 4 inches (152 mm) on all edges, unless a lesser spacing is used in accordance with Section E11.3 to adjust the required shearwall length.

In *braced wall lines*, all edges of wood *structural sheathing* panels or *steel sheets* shall be attached to framing members, 33 mil minimum *blocking*, or 2 inch (51 mm) by 33 mil (0.84 mm) flat *strap*. Fasteners along the edges in shear panels shall be placed not less than 3/8 inches (9.5 mm) in from panel edges.

E11.3 Type I (Solid Sheathed) Braced Wall Panels

Type I braced wall panels shall have no openings and shall be continuous between *hold-down* anchors. *Hold-down* anchors shall be as required by Section E11.5.

For a wall panel to count toward the required length, it shall have a maximum height-to-width ratio of 2:1.

The required length of *braced wall line* full-height sheathing is permitted to be adjusted by the edge screw spacing adjustment factors in Table E11-1. The total length of *Type I braced wall panels* on a *braced wall line* shall be the sum of the lengths of panels conforming to the maximum height-to-width ratio herein. *Type I braced wall panels* shall have *hold-down* anchors as required by Section E11.5 at each end of each panel segment.

E11.4 Type II (Perforated) Braced Wall Lines

Type II braced walls are permitted to have openings. Where sheathing, of a type specified in Section E11.2 and attached in accordance with that section, extends above and below window openings and above door openings, the height of the unrestrained opening shall be defined as the maximum opening height. Where such sheathing is not provided or does not comply with the minimum width requirements above and below window openings and above door openings, the height of the unrestrained opening shall be defined as the full height of the wall.

The required length of *braced wall line* full-height sheathing panels as a percentage of overall length of *Type II braced wall* shall be determined by multiplying the required length of *Type I braced wall panels*, as modified by the adjustments permitted in Section E11.3, by the length adjustment factors in Table E11-2. For a segment to count toward the required length it shall have a maximum height-to-width ratio of 2:1. *Type II braced wall lines* shall have *hold-down* anchors as required by Section E11.5 at each end, which shall be attached to wall segments meeting the maximum height-to-width ratio.

E11.5 Braced Wall Anchorage and Chord Stud Requirements

Hold-down anchors shall be installed at each end of *Type I braced wall panels* and at each end of *Type II braced wall lines* as shown in Figure E11-1. Anchors shall be attached to a minimum of two back-to-back *chord studs*. Minimum *chord stud* thickness shall be 33 mils (0.84 mm). These *chord studs* shall have the required sheathing edge fastening (see Figure E11-3). *Hold-down* anchors shall attach to the foundation or to framing members below which have the same or greater strength as the *chord studs* above, and which are in addition to the typical load bearing framing. Where *hold-down* anchors attach to framing members below, the required anchor force shall be transferred to the foundation. Where *hold-down* anchors from an upper story align with those at the lower story, the required lower story anchor force and the required lower story *chord stud* strength shall be determined by summing the upper and lower story chord forces (see Figure E11-4).

A single *hold-down* anchor installed in accordance with Figure E11-2 is permitted at the corners of buildings.

E11.6 Attachment of Braced Walls to Foundations and Floor and Roof Diaphragms

The top *track* of *braced wall lines* shall be attached directly to the roof sheathing in accordance with Figure E11-5, or shall have *blocking* connecting the top *track* to the continuous flat *strap* at the roof sheathing at locations specified herein and installed in accordance with Figure E11-6. *Blocking* shall be installed at each end of *Type I braced wall panels*, at each end of *Type II braced wall lines*, at building corners, and at 4 feet (1.22 m) on-center maximum.

Splices in top *tracks* in braced walls shall comply with Figure E11-7. Screws used to attach *blocking* to the top *track* are permitted to be counted toward the required number of *track* splice screws. Splices in the top *track* and the *strap* at the roof sheathing shall not occur in the same *stud* bay.

The top and bottom *track* of braced walls shall be attached to floor *diaphragms* in accordance with Figure E11-8.

Splices in the *rim track* shall not occur in the same bay as splices in wall *track* immediately above or below the *rim track* splice. The minimum offset between splice locations shall be two *stud* bays.

The bottom *track* of braced walls supported on foundations shall have anchor bolts installed in accordance with Figure E11-9 or E11-10. Floor *track* or rim joists supporting *braced wall lines* shall be attached to foundations in accordance with Figure E11-11 or E11-12. Anchor bolts shall extend 15 inches (381 mm) into masonry or 7 inches (178 mm) into concrete. An anchor bolt shall be located not more than 12 inches (305 mm) from wall corners, the termination of bottom *track* sections, or splices in the brake shape shown in Figure E11-11 or E11-12.

E12 Braced Wall Design in High Seismic Areas

In *high seismic areas* the design of braced walls shall comply with this section, in addition to the requirements in Section E11.

E12.1 Length of Type I Braced Wall Panels

The required length of *Type I braced wall panels* shall be determined from Tables E12-1 through E12-15, where the *diaphragm span* is the dimension of the *diaphragm* perpendicular to the walls under consideration. Linear interpolation is permitted for determining *diaphragm span* values.

The required length of *Type I braced wall panels* shall be increased by the length adjustment factors in Table E12-16 where the dead weight of the roof/ceiling assembly is greater than 15 psf and meets the criteria for *heavyweight roof/ceiling assembly*. The required length of *Type I braced wall panels* is permitted to be adjusted by length adjustment factors in Table E12-16 where the average weight of the roof/ceiling assembly meets the criteria for a lightweight roof/ceiling or the exterior walls meet the criteria for lightweight exterior walls. Linear interpolation is permitted for roof/ceiling dead unit weights between 15 and 25 psf (0.72 and 1.20 kN/m²). The length adjustment factors in Table E12-16 are permitted to be multiplied by those in Table E11-1.

E12.2 Braced Wall Anchorage and Chord Stud Requirements

Minimum *hold-down* anchor strengths to resist uplift in *Seismic Design Categories D₁* and *D₂* shall be as specified in Table E12-17. Published *hold-down* anchor strengths that have been increased for wind or earthquake forces shall be reduced to their base values. Required *hold-down* anchor strengths for anchors at the first floor of two-story buildings and the first or second floor of three-story buildings, which resist uplift from two or three stories, shall be determined by summing the required strengths for all floors. A continuous load path shall be provided from each *hold-down* anchor to the foundation.

Maximum anchor bolt spacing requirements for transfer of shear loads shall be as specified in Table E12-18.

Required *chord stud* strength shall be determined from Table E12-17, and a *chord stud* having the required strength shall be selected from Table E12-19. *Chord stud* requirements for *chord studs* at the first-floor of two-story buildings and the first or second floor of three-story buildings, where the first-floor *chord studs* align with *chord studs* at the floor above, shall be determined by summing the required strengths for all floors. Where one pair of back-to-back *studs* does not have adequate strength to resist the sum of the accumulated chord forces, two pair of back-to-back *studs* shall be used at the lower floors as shown in Figure E11-3.

E12.3 Wall Top Track

The top *track* thickness of walls supporting floor or roof *diaphragms*, and the number of screws in the top *track* splices, shall be as required in Table E12-20. Minimum top *track* thickness shall be 33 mil (0.84 mm), except where indicated by shading in Table E12-20. In locations indicated by shading in Table E12-20, minimum top *track* thickness shall be 43 mils (1.09 mm).

E13 Braced Wall Design in High Wind Areas

E13.1 General

In *high wind areas* the design of braced walls shall comply with this section, in addition to the requirements in Section E11.

Braced walls shall be covered with *structural sheathing* on one side as required and the other side shall be covered by minimum 1/2-inch (12.7-mm) gypsum board.

For the purpose of this section, the endwall shall be defined as the exterior wall of the building perpendicular to the roof *ridge* and the sidewall shall be defined as the exterior wall of the building parallel to the roof *ridge*. For the purposes of determining uplift and lateral *bracing* requirements, the attic shall be considered as an additional story when the roof slope is greater than 6.9 in 12.

E13.2 Length of Braced Walls

The minimum and maximum allowable sidewall lengths shall be determined from Tables

E13-1 and E13-2.

The required length of *Type I braced wall panels* shall be determined from Tables E13-3 and E13-4. For 9-foot (2.74 m) wall heights, the tabulated values shall be multiplied by 1.13. For 10-foot (3.05 m) wall heights, the tabulated values shall be multiplied by 1.25. For *mean roof heights* of 15 feet (4.92 m) or less, the tabulated values are permitted to be multiplied by 0.8. Required lengths are permitted to be multiplied by the adjustment factors in Table E11-1 for edge screw spacing other than 6 inches (152 mm), but the resulting sheathing length shall not be less than 5 feet (1.64 m).

Braced wall *hold-down* anchors shall comply with Section E11.5. The height-to-width aspect ratio of *Type I braced wall panels* shall be limited to 3.5:1. The height-to-width aspect ratio of full-height sheathing segments in *Type II braced walls* shall be limited to 2:1.

Wood *structural sheathing* panels or structural *steel sheet* shall comply with Section E11.2 except in regions where the *basic wind speed* exceeds 130 mph (225 km/hr). Wood *structural sheathing* panels attached to framing spaced 24 inches (610 mm) o.c. shall be a minimum of 19/32 inch (15.1 mm).

E13.3 Connections of Walls in High Wind Areas

E13.3.1 General

In *high wind areas*, walls shall be connected, as required by this section, to ensure a continuous load path capable of transferring shear and uplift loads from floors, *studs*, and roof framing to the foundation.

E13.3.2 Uplift Connection - Wall Assembly to Wall Assembly

Exterior wall *studs* in the upper story wall of a two- or three-story building shall be attached to the *in-line framing* wall *studs* in the supporting wall below with connections capable of resisting the uplift loads listed in Table E13-5. Alternatively, a steel uplift *strap* sized in accordance with Table E13-9 is permitted with minimum No. 8 screws attached to each *stud*, as required by Table E13-6.

E13.3.3 Header Uplift Connections

When it is necessary to make an uplift *strap* connection to a back-to-back *header*, the *header* beam shall be reinforced as shown in Figure E13-1. Uplift *straps* shall be installed on both sides of a back-to-back *header* beam (inside and outside of the wall) when the *header* is supporting loads from the roof and ceiling only.

E13.3.3.1 Single Story or Top of a Two- or Three-Story Building

Uplift connections shall be provided to fasten the *roof rafter* or roof *trusses* to the *header* by connectors capable of resisting the uplift loads listed in Table E13-7.

Uplift connections shall be provided to fasten the *header* to the *jack studs* by connectors capable of resisting the uplift loads listed in Table E13-7, multiplied by the number of framing members displaced, divided by two. An additional uplift *strap* shall be provided to fasten *roof rafters* or roof *trusses* to *king studs* that provide *in-line framing* support in accordance with Table E13-7.

Uplift connections shall be provided to fasten the *jack studs* to the foundation by connectors capable of resisting the uplift loads listed in Table E13-7, multiplied by the number of framing members displaced, divided by two.

As an alternative to the connectors required above, a steel uplift *strap* sized in accordance with Table E13-9 is permitted with minimum No. 8 screws attached to each

stud, as required by Table E13-8.

E13.3.3.2 Middle and Bottom Stories of a Two- or Three-Story Building

Uplift connections shall be provided to fasten the exterior wall *studs* in the upper story walls of a two- or three-story building to the *header* below by connections capable of resisting the uplift loads listed in Table E13-5.

Uplift connections shall be provided to fasten the *header* to the *jack studs* by connectors capable of resisting the uplift loads listed in Table E13-5, multiplied by the number of framing members displaced, divided by two. An additional uplift *strap* shall be provided to fasten exterior wall *studs* in the upper story to *king studs* that provide *in-line framing* support in accordance with Table E13-5.

Uplift connections shall be provided to fasten the *jack studs* to the foundation by connectors capable of resisting the uplift loads listed in Table E13-5, multiplied by the number of framing members displaced, divided by two.

As an alternative to the connectors required above, a steel uplift *strap* sized in accordance with Table E13-9 is permitted with minimum No. 8 screws attached to each *stud*, as required by Table E13-6.

E13.3.4 Wall Bottom Track to Foundation

Bottom *track* of exterior walls shall be connected to a wood sill plate as shown in Figure E2-5. The *track* shall be attached with steel plates spaced at 2 feet (0.61 m) on center and fastened with 4-No. 8 screws, 4-10d or 6-8d common nails. Bottom *track* of interior braced walls shall be connected to supporting floors or foundations as required by Section E2.

The bottom *track* shall be connected to the foundation with 1/2-inch (13-mm) anchor bolts extending 14 inches (381 mm) into masonry or 7 inches (178 mm) into concrete. Anchor bolts shall be spaced a maximum of 3 feet (0.915 m) on center, with the following exceptions:

1. Anchor bolts located within the 8-foot (2.44-m) end zone in regions with a *basic wind speed* of 150 mph (241 km/hr) or greater shall be spaced a maximum of 2 feet (0.610 m) on center.
2. Anchor bolts located in exterior braced wall in which the perimeter screw spacing is less than 6 inches (152 mm) on center shall be spaced a maximum of 1-1/2 feet (0.457 m) on center.
3. An anchor bolt shall be located no more than 12 inches (305 mm) from wall corners or the termination of bottom *track* sections.

E13.4 Braced Wall Anchorage and Chord Stud Requirements

Minimum *hold-down* anchor strengths to resist uplift in *high wind areas* shall be as specified in Table E13-10. Published *hold-down* anchor strengths that have been increased for wind or earthquake forces shall be reduced to their base values. Required *hold-down* anchor strengths for anchors at the first floor of two-story buildings and the first or second floor of three-story buildings, which resist uplift from two or three stories, shall be determined by summing the required strengths for all floors.

Required *chord stud* strength shall be determined from Table E13-10, and a *chord stud* having the required strength shall be selected from Table E12-19. *Chord stud* requirements for *chord studs* at the first floor of two-story buildings and the first or second floor of three-story buildings, where the first floor *chord studs* align with *chord studs* at the floor above, shall be determined by summing the required strengths for all floors. Where one pair of back-to-back *studs* does not have adequate strength to resist the sum of the accumulated

chord forces, two pairs of back-to-back *studs* shall be used at the lower floors as shown in Figure E11-3.

Required strengths in Table E13-10 are permitted to be multiplied by a factor equal to the required full-height sheathing length divided by the actual full-height sheathing length that is provided.

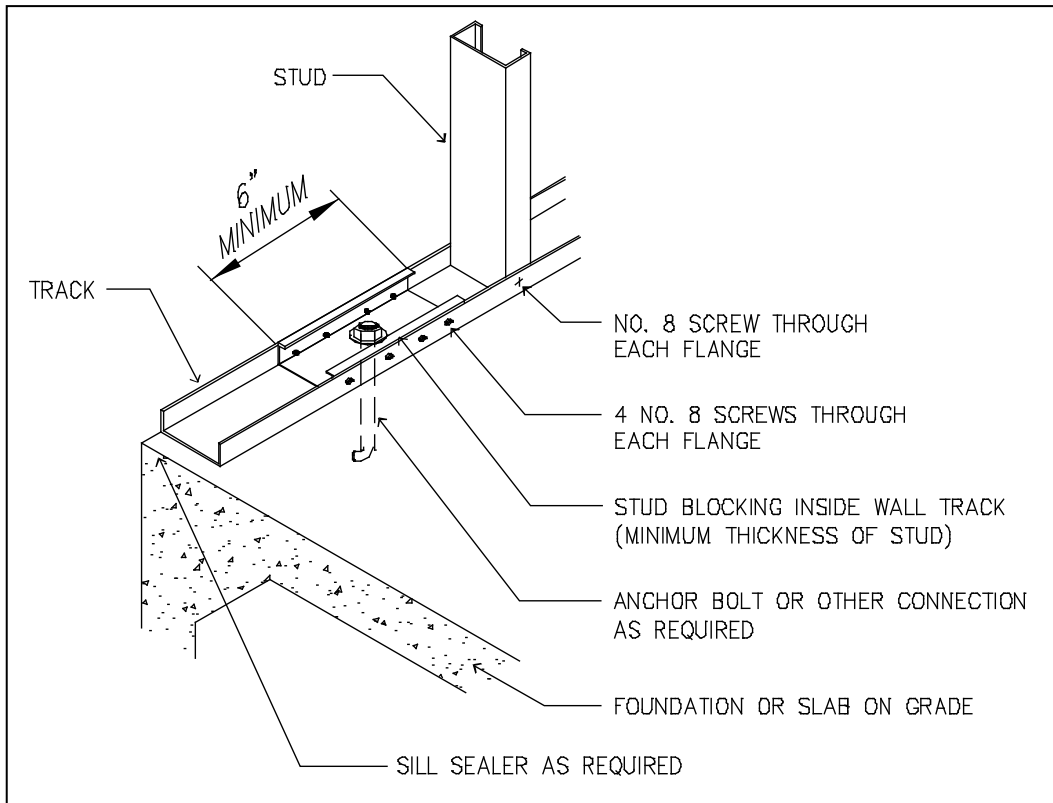

Figure E2-1 Wall to Foundation Connection

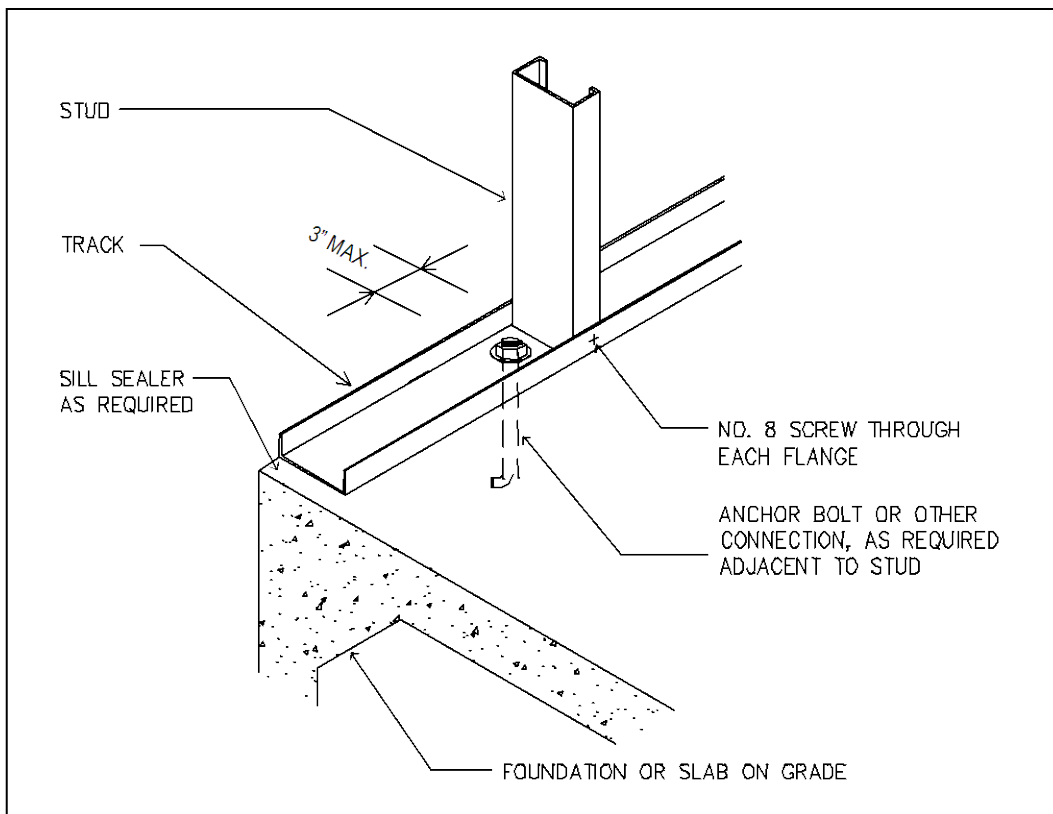

Figure E2-2 Alternate Wall to Foundation Connection

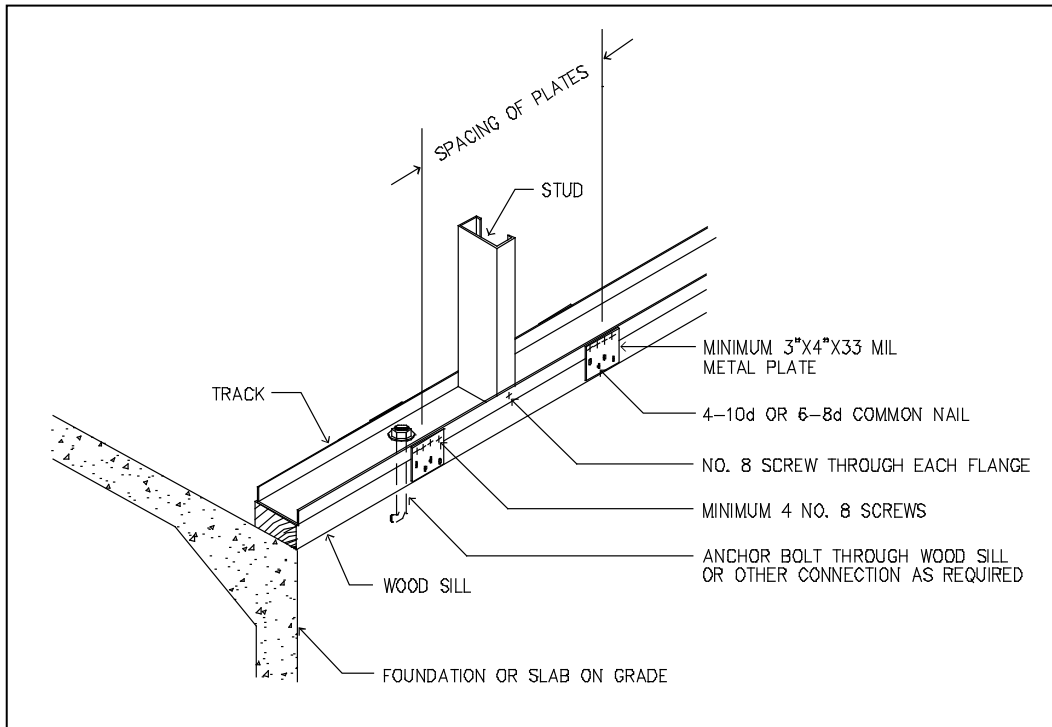

Figure E2-3 Wall to Wood Sill Connection

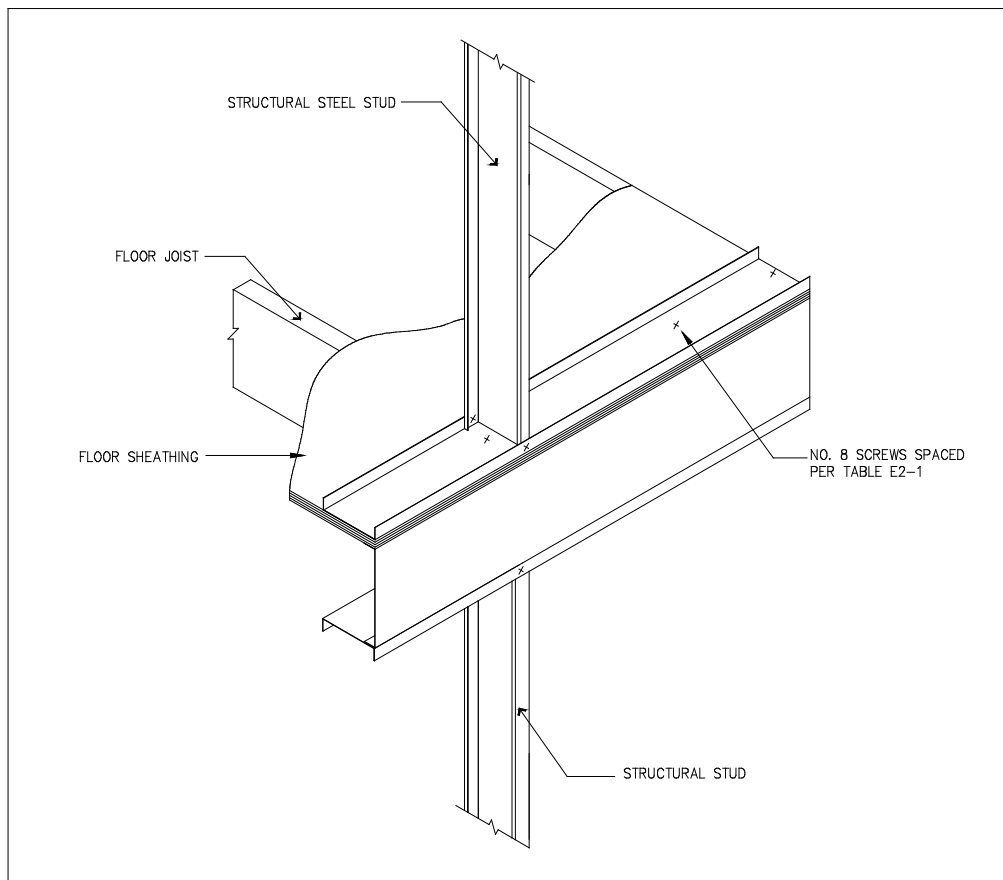

Figure E2-4 Wall to Floor Connection

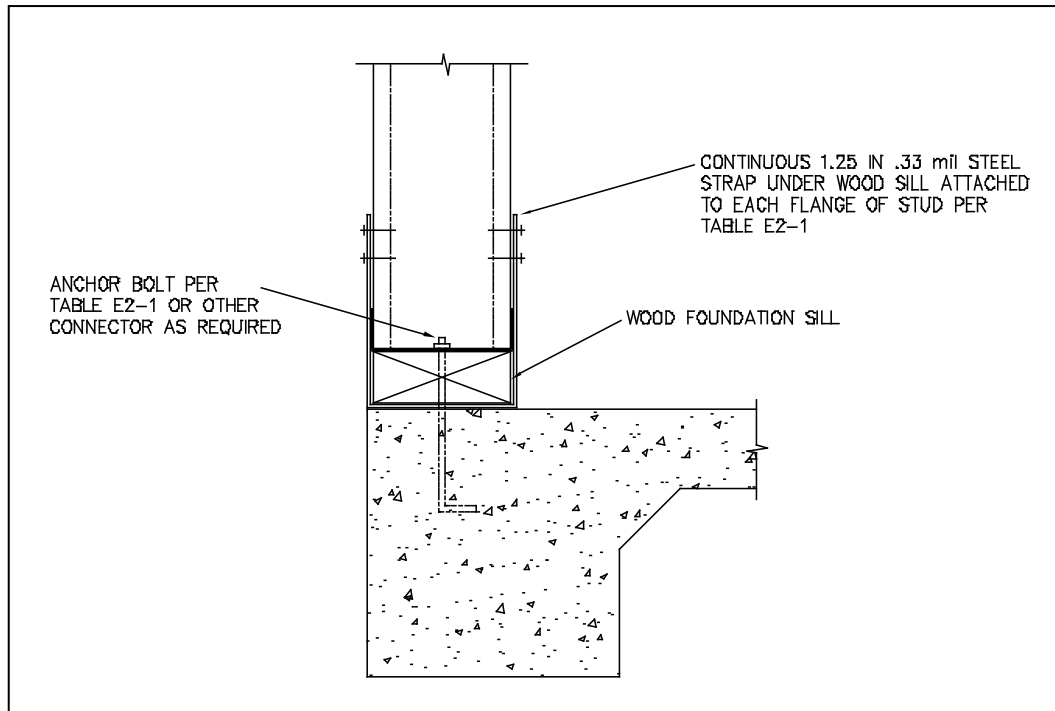

Figure E2-5 Wind Uplift Connector

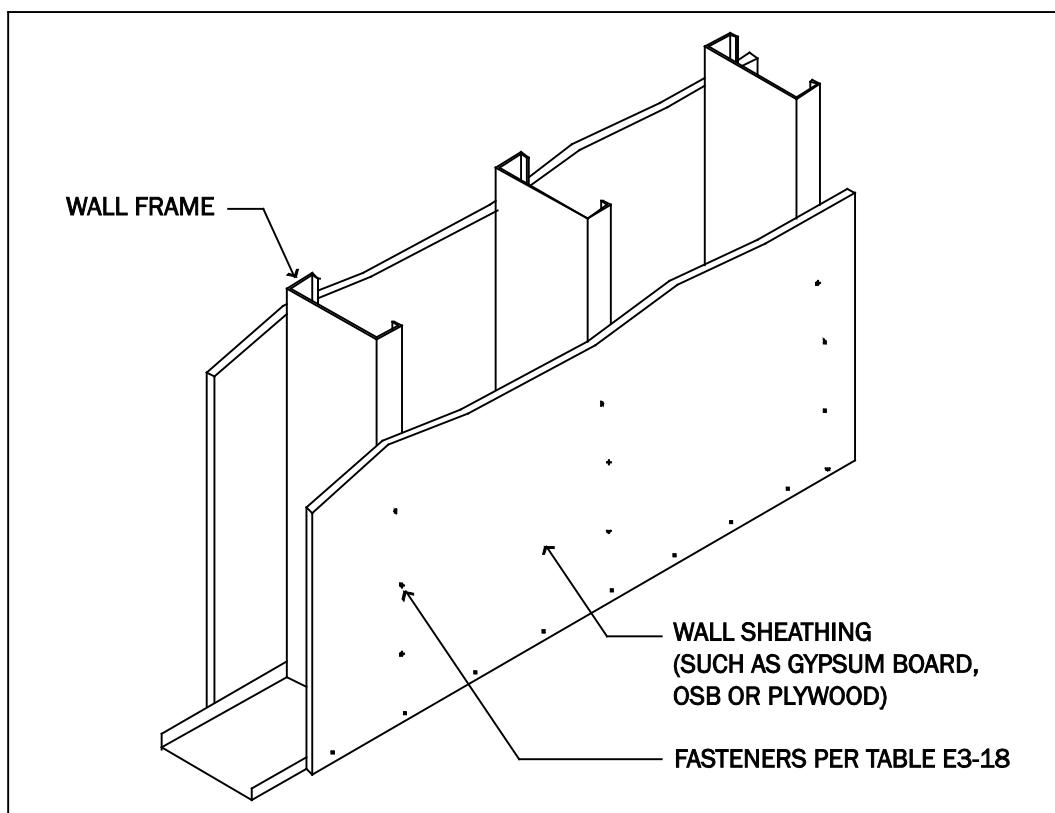

Figure E4-1 Stud Bracing With Sheathing Material Only

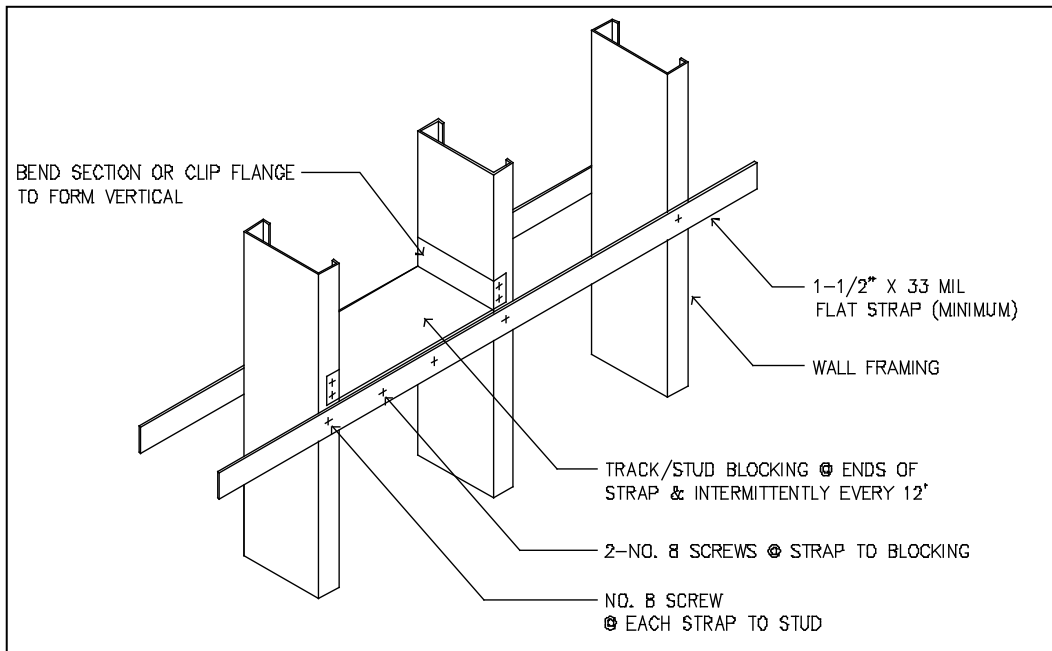

Figure E4-2 Stud Bracing With Strapping Only

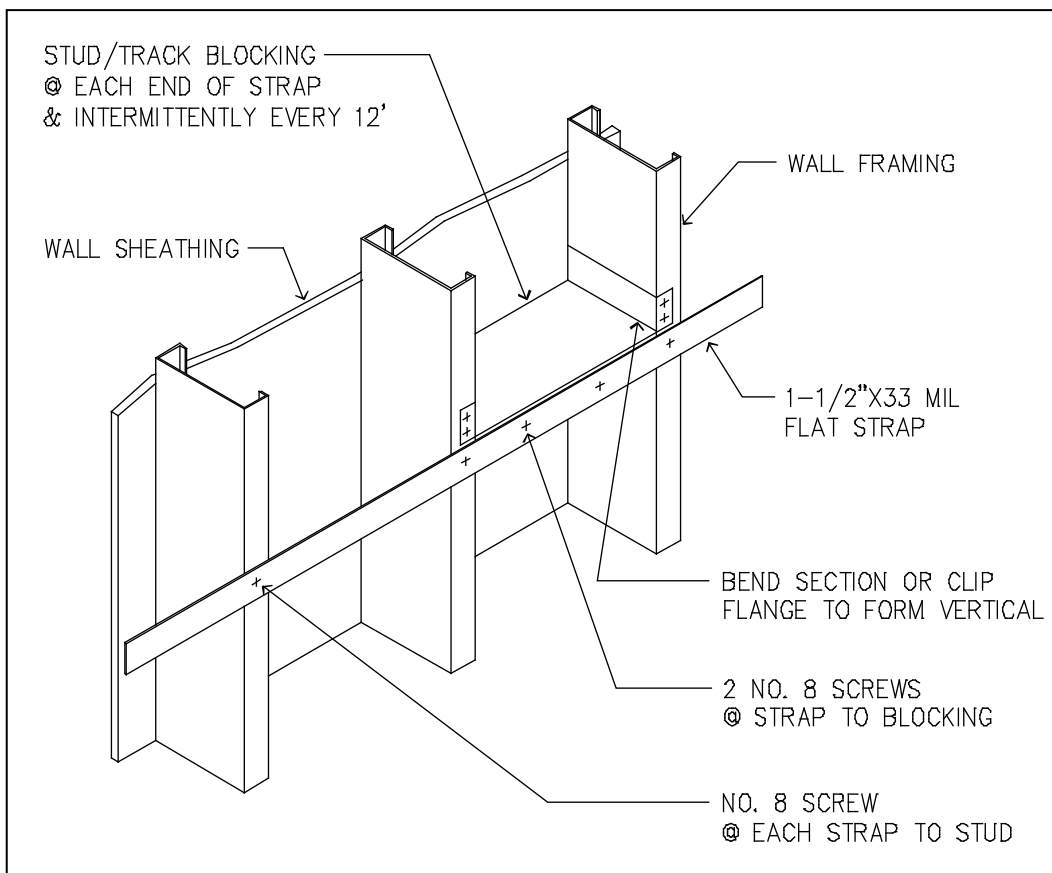

Figure E4-3 Stud Bracing With Strapping and Sheathing Material

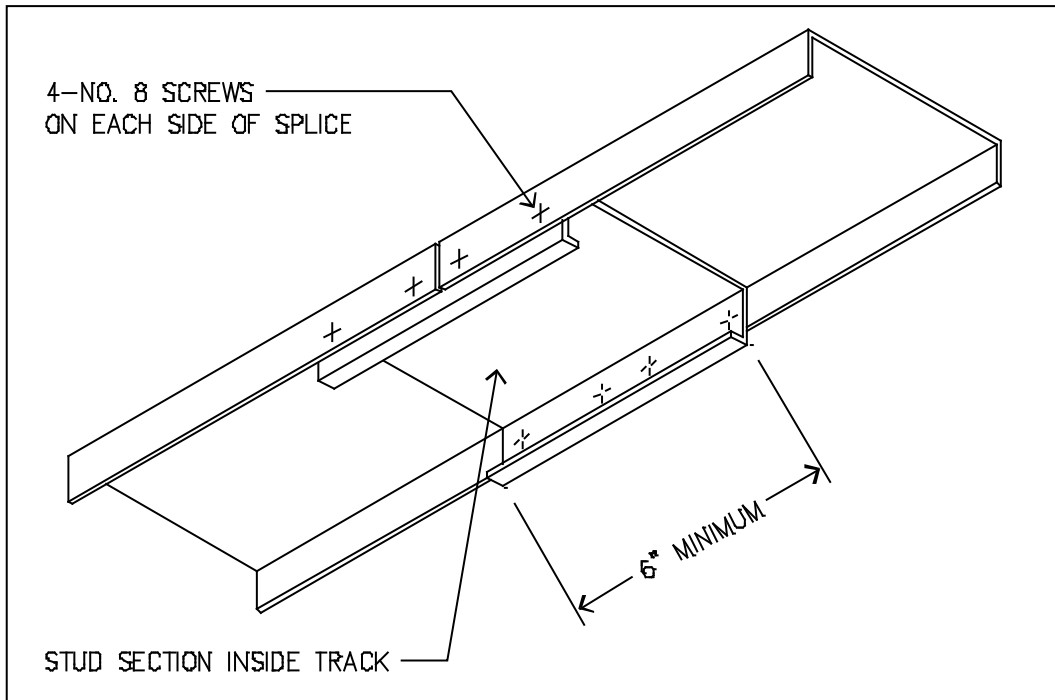

Figure E5-1 Top Track Splice

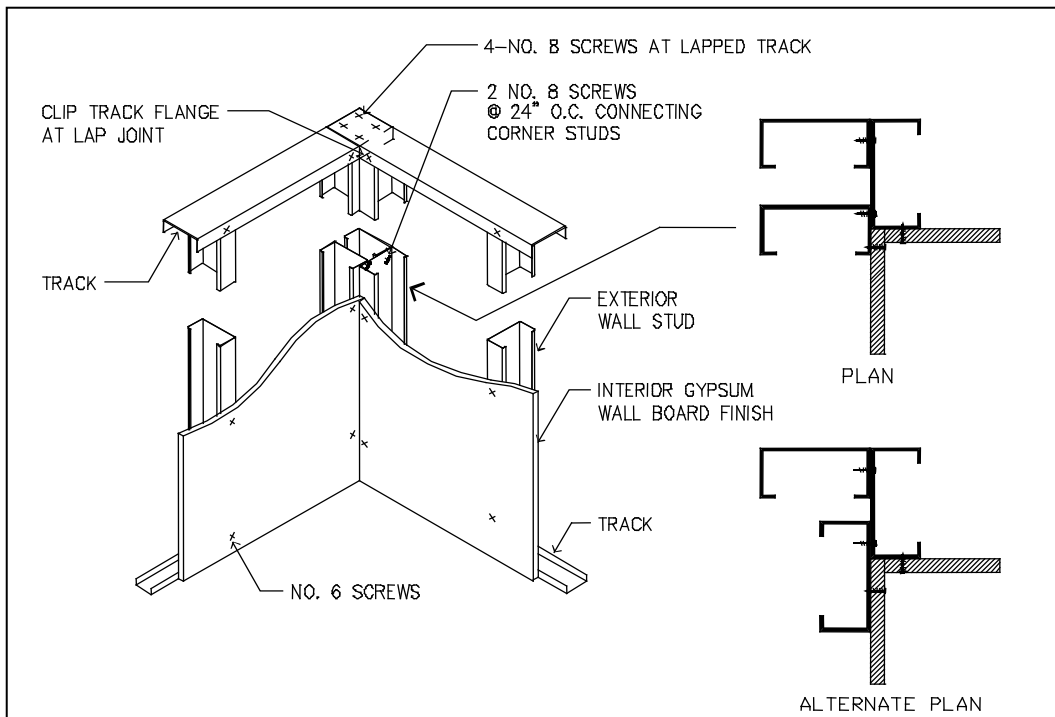

Figure E6-1 Corner Framing Detail

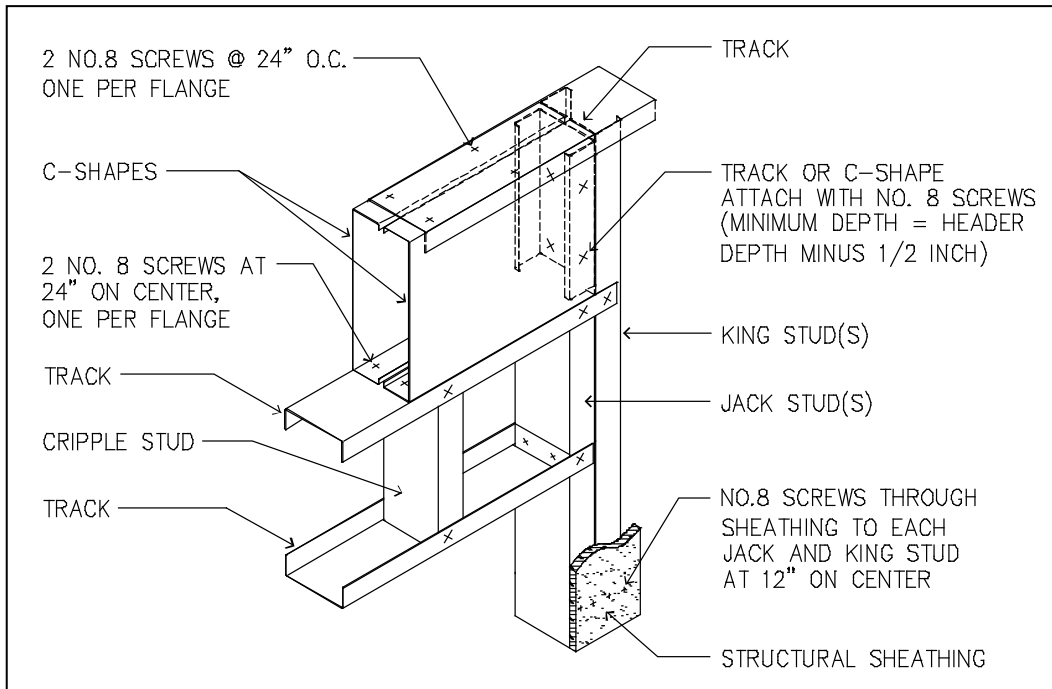

Figure E7-1 Box-Beam Header Detail

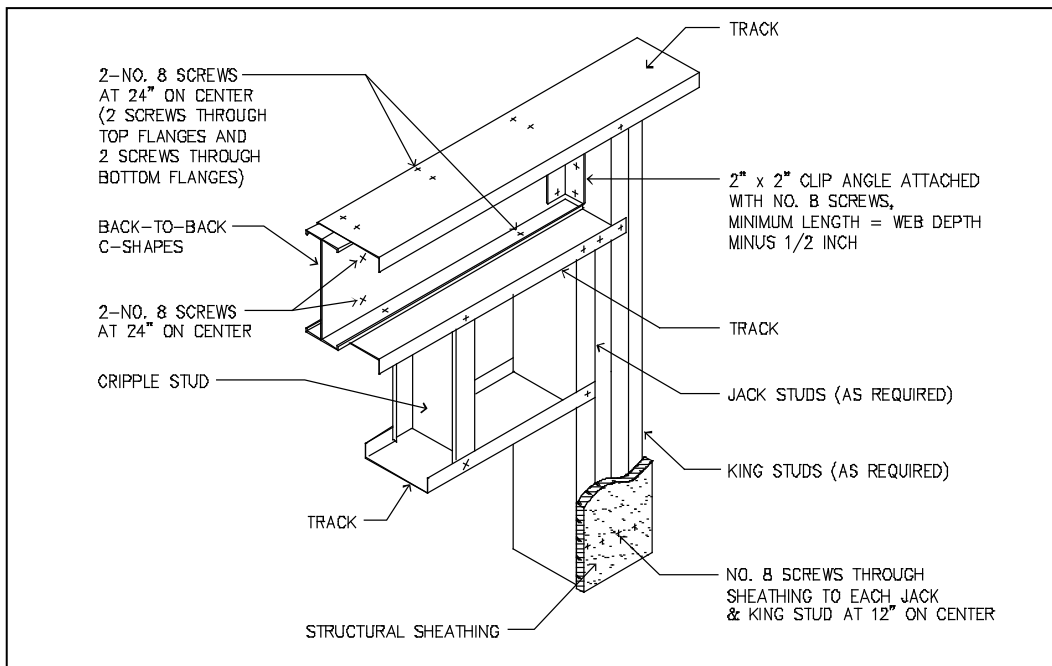

Figure E7-2 Back-to-Back Header Detail

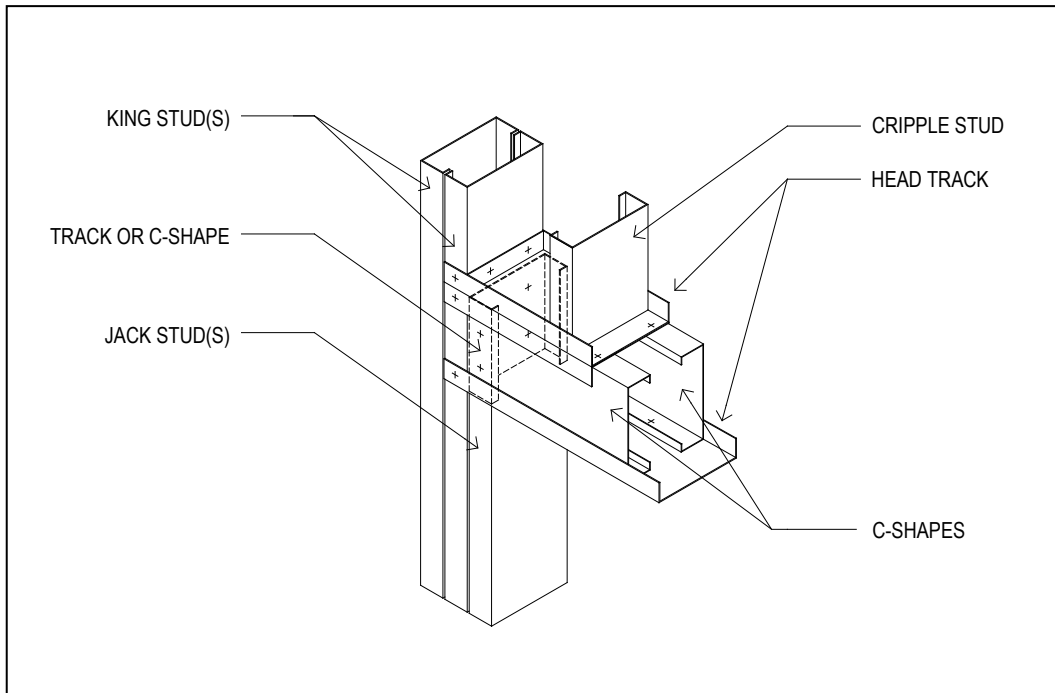

Figure E7-3 Box-Beam Header in Gable Endwall

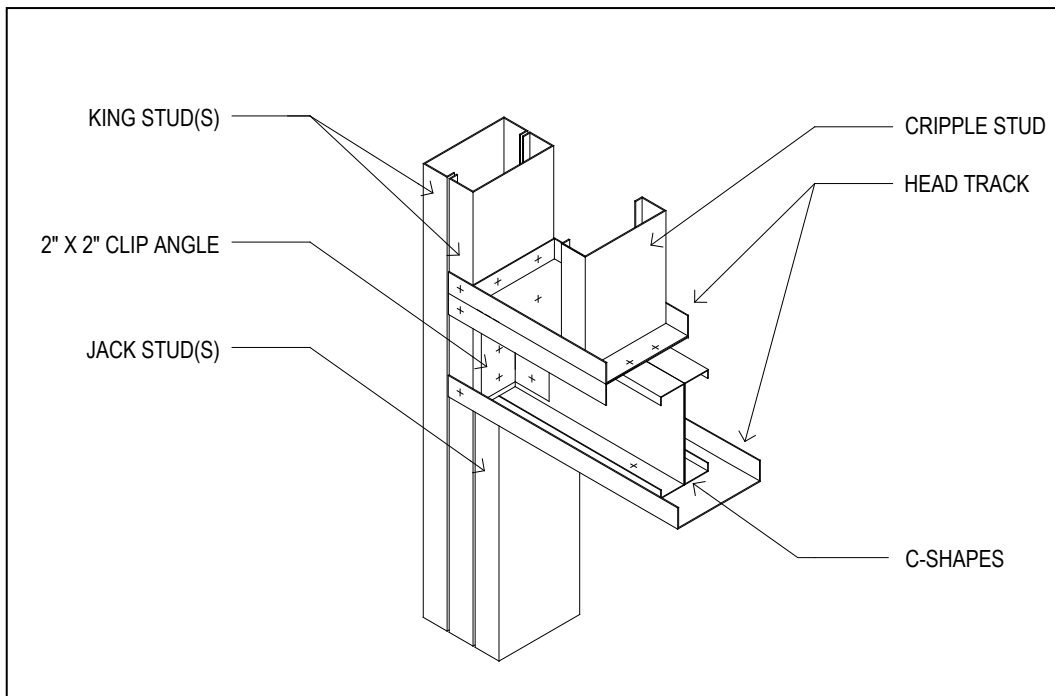

Figure E7-4 Back-to-Back Header in Gable Endwall

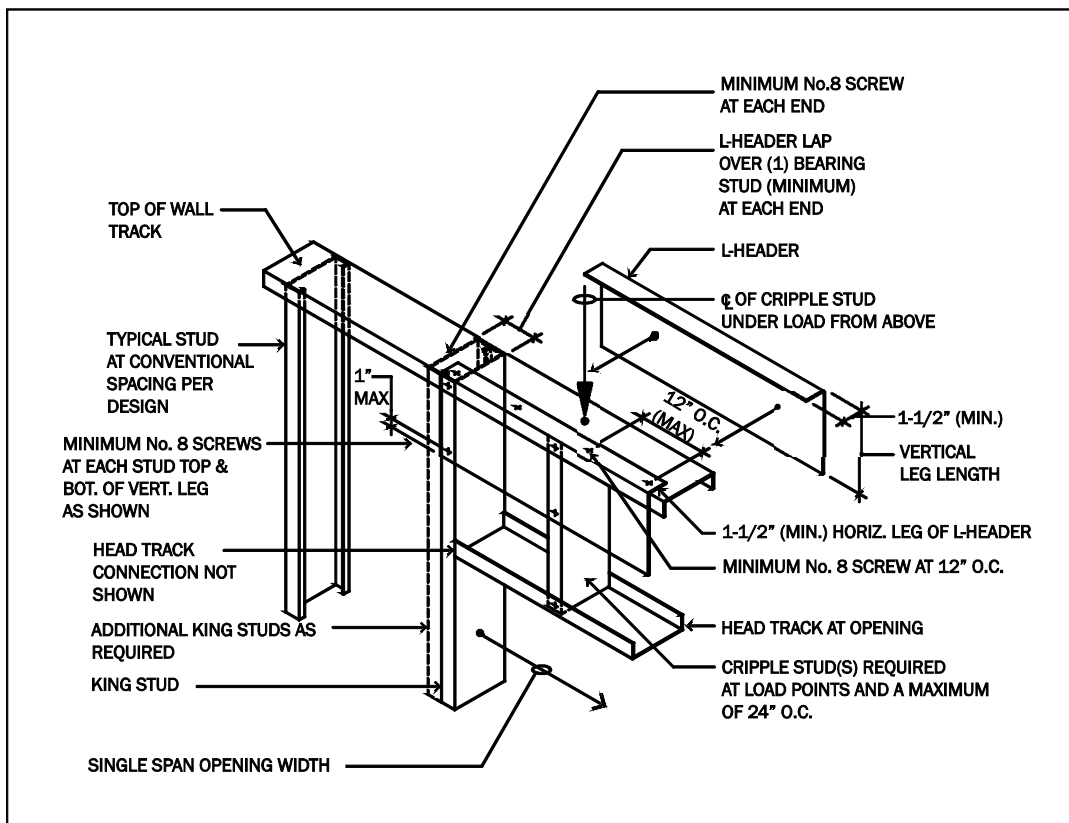

Figure E7-5 Double L-Header

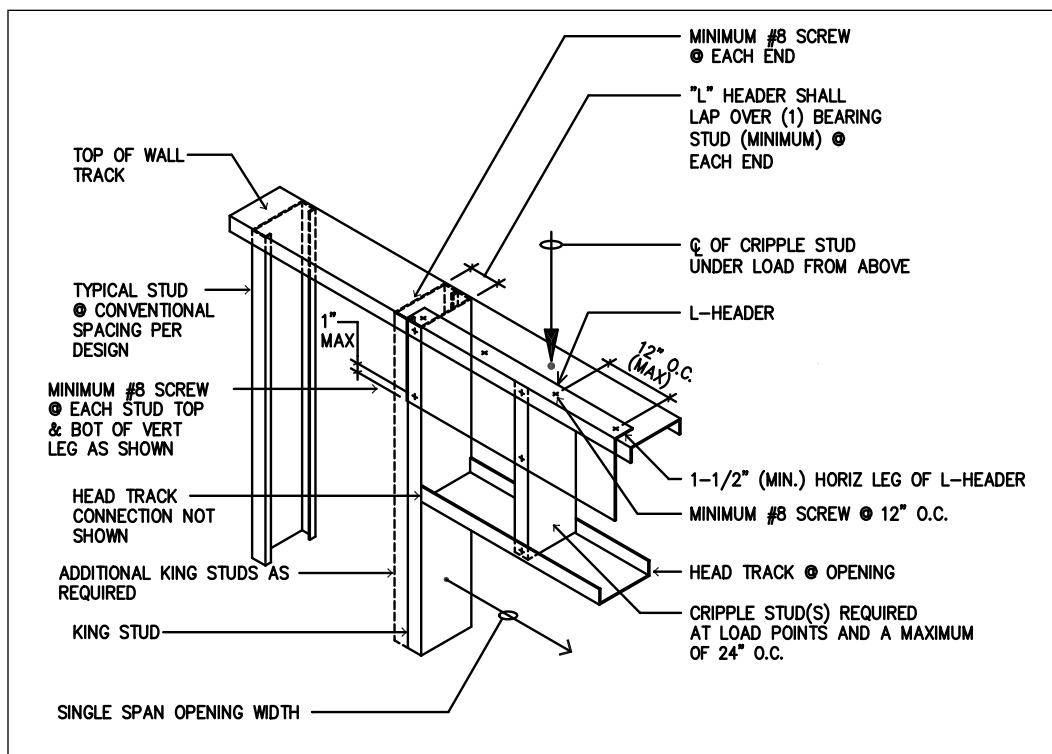

Figure E7-6 Single L-Header

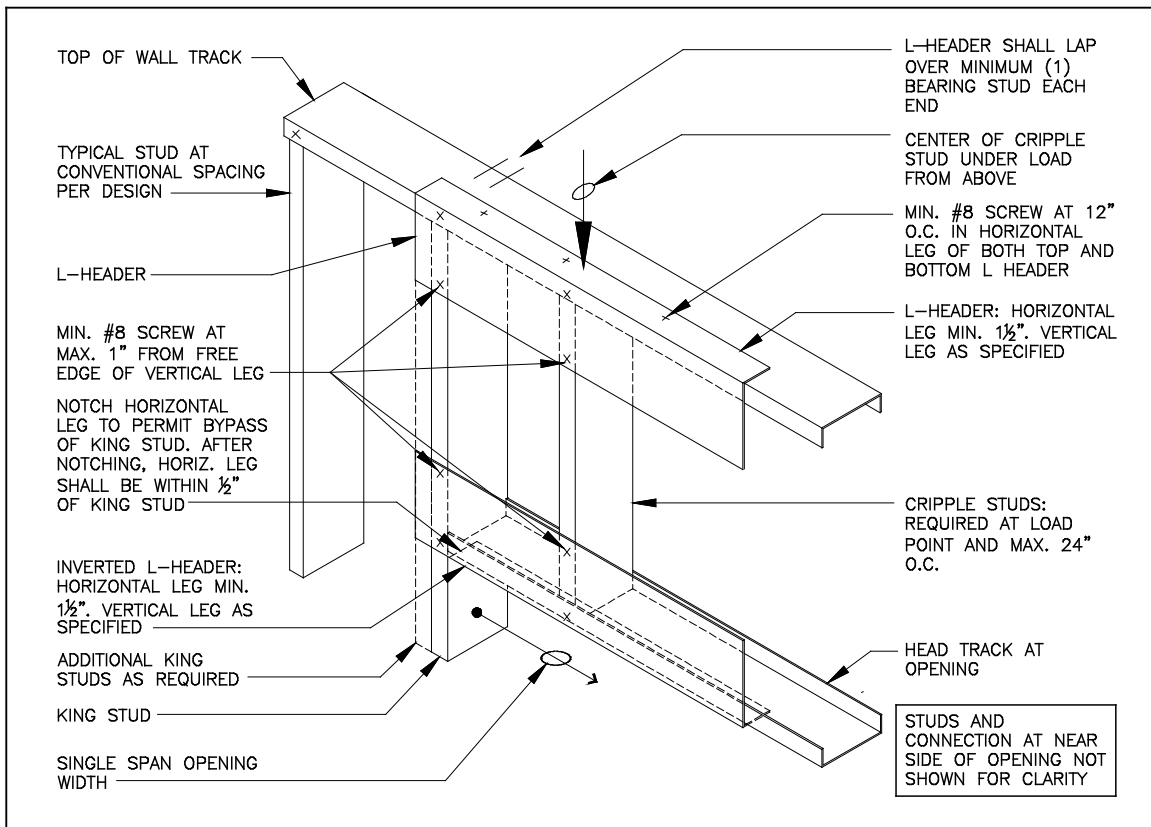

Figure E7-7 Inverted Single or Double L-Header Assembly (Single L-Header Shown)

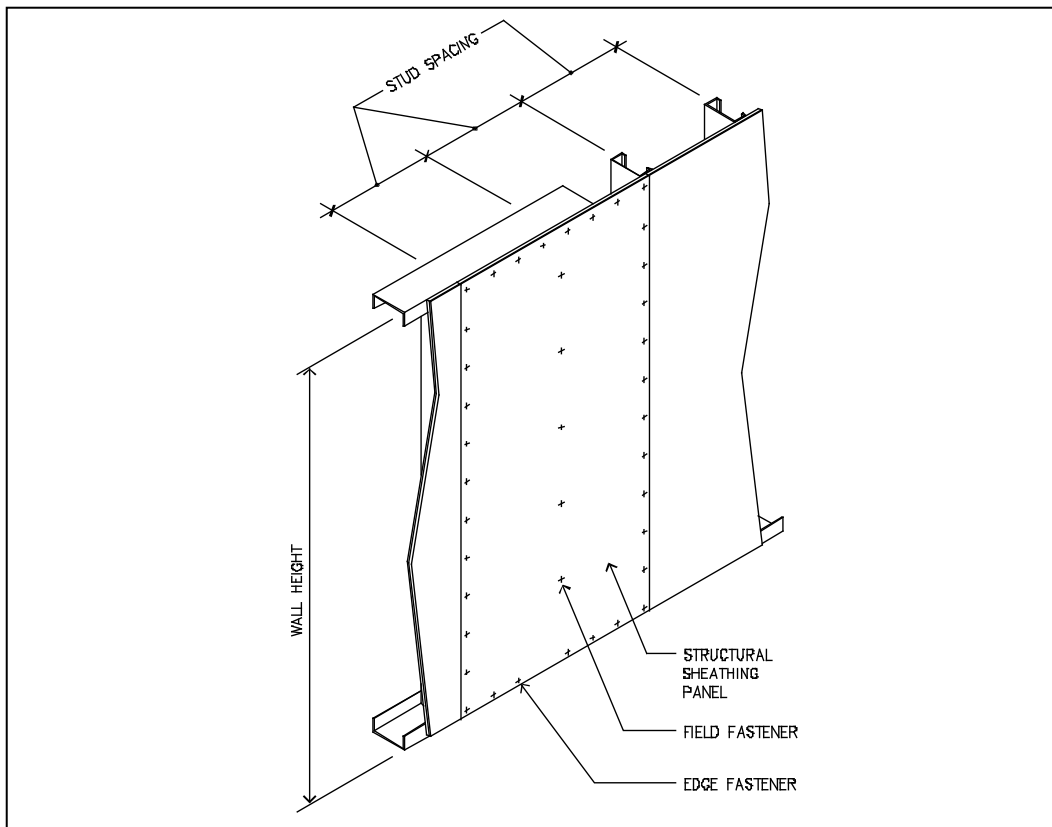

Figure E8-1 Structural Sheathing Fastening Pattern

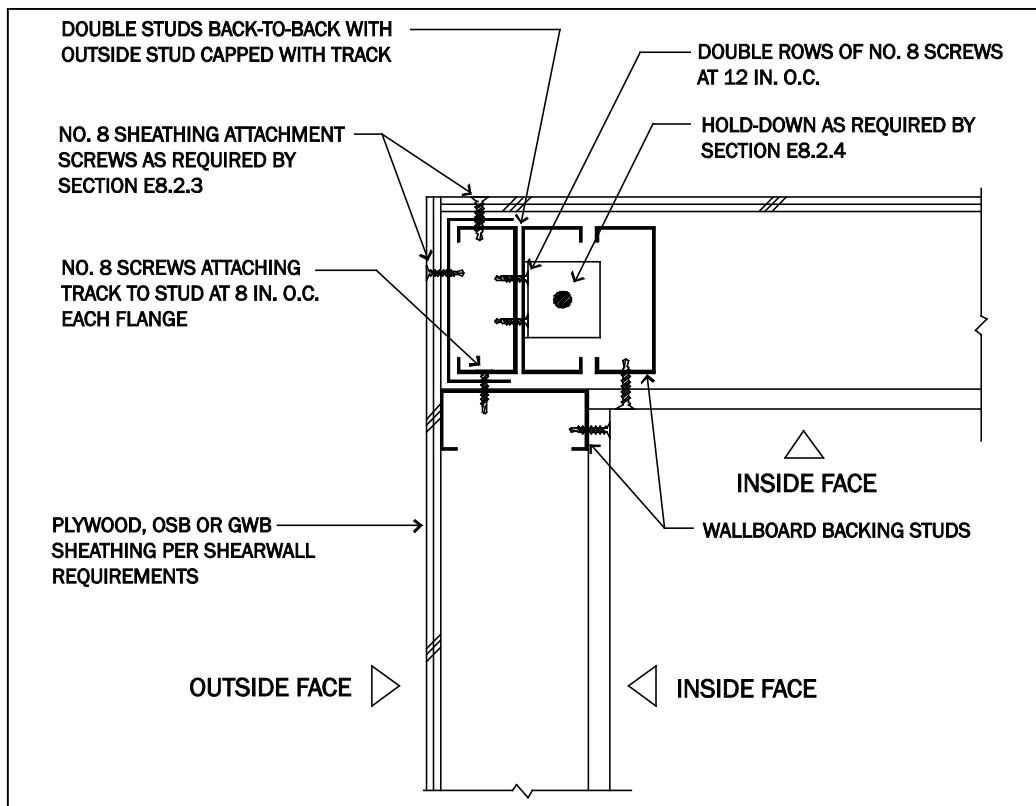

Figure E8-2 Corner Stud Hold-Down Detail

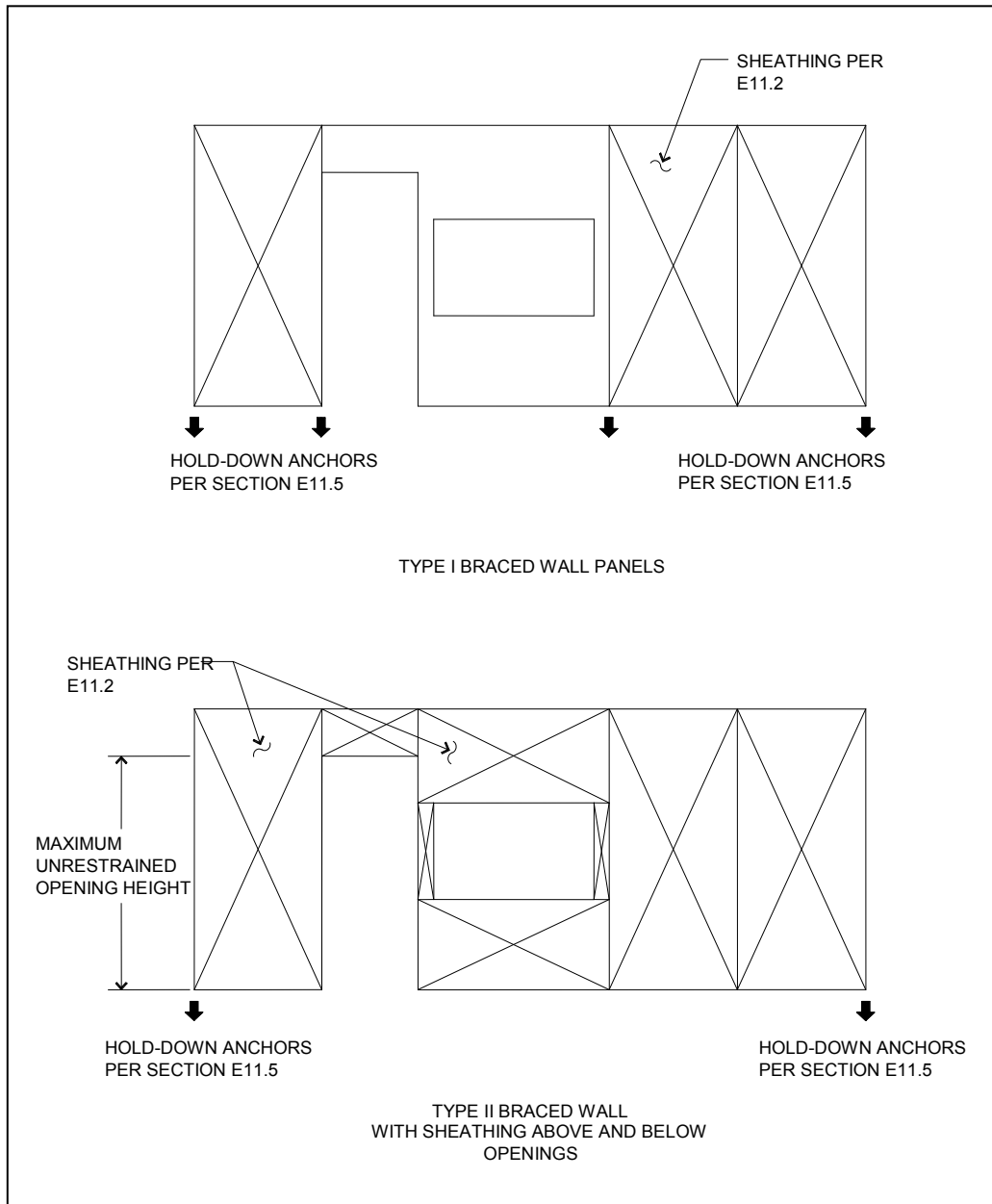

Figure E11-1 Type I and Type II Braced Wall Lines

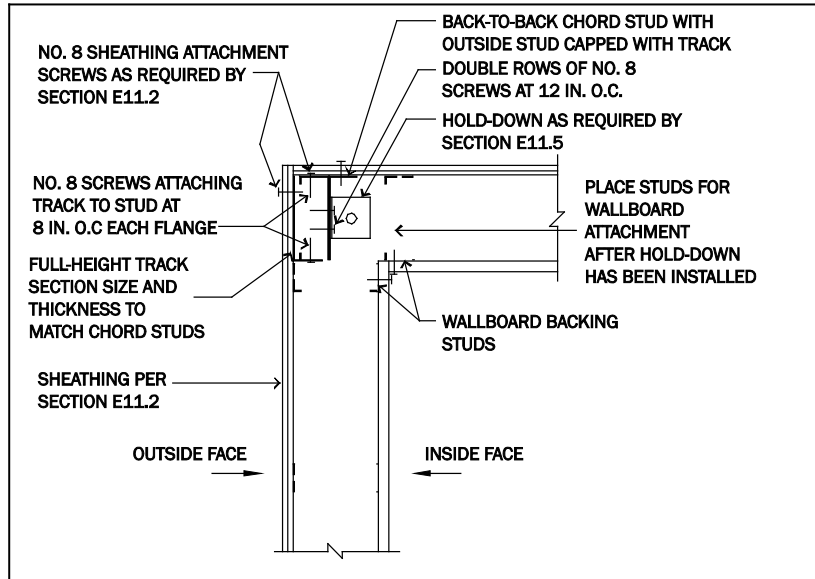

Figure E11-2 Corner Stud Hold-Down

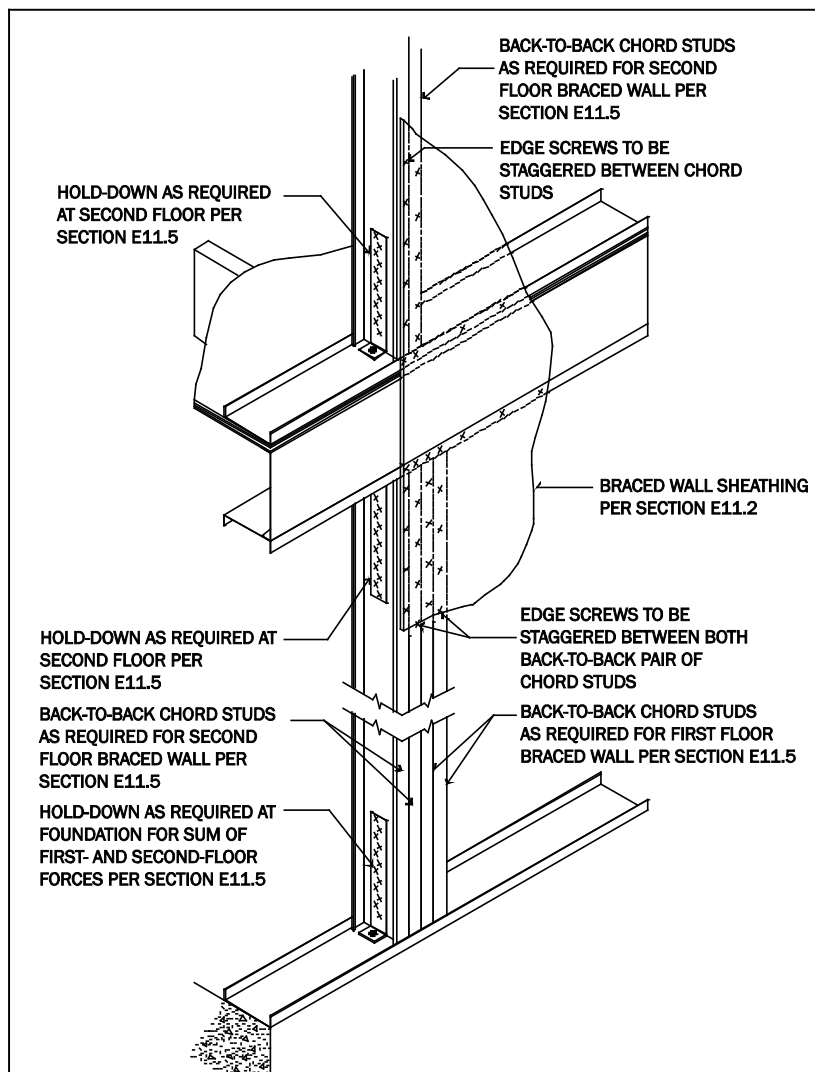

Figure E11-3 Supplemental Chord Stud at First Floor

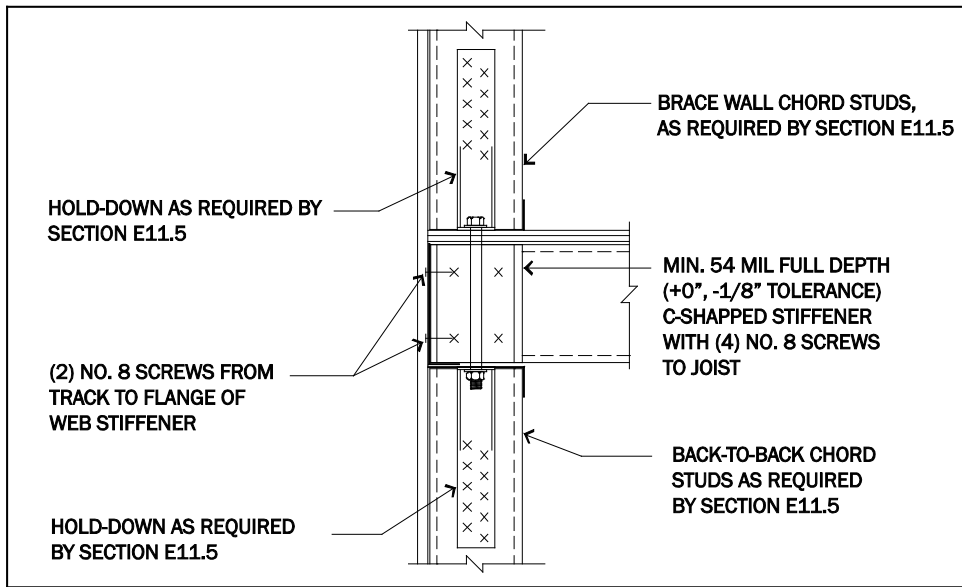

Figure E11-4 Floor to Floor Hold-Down

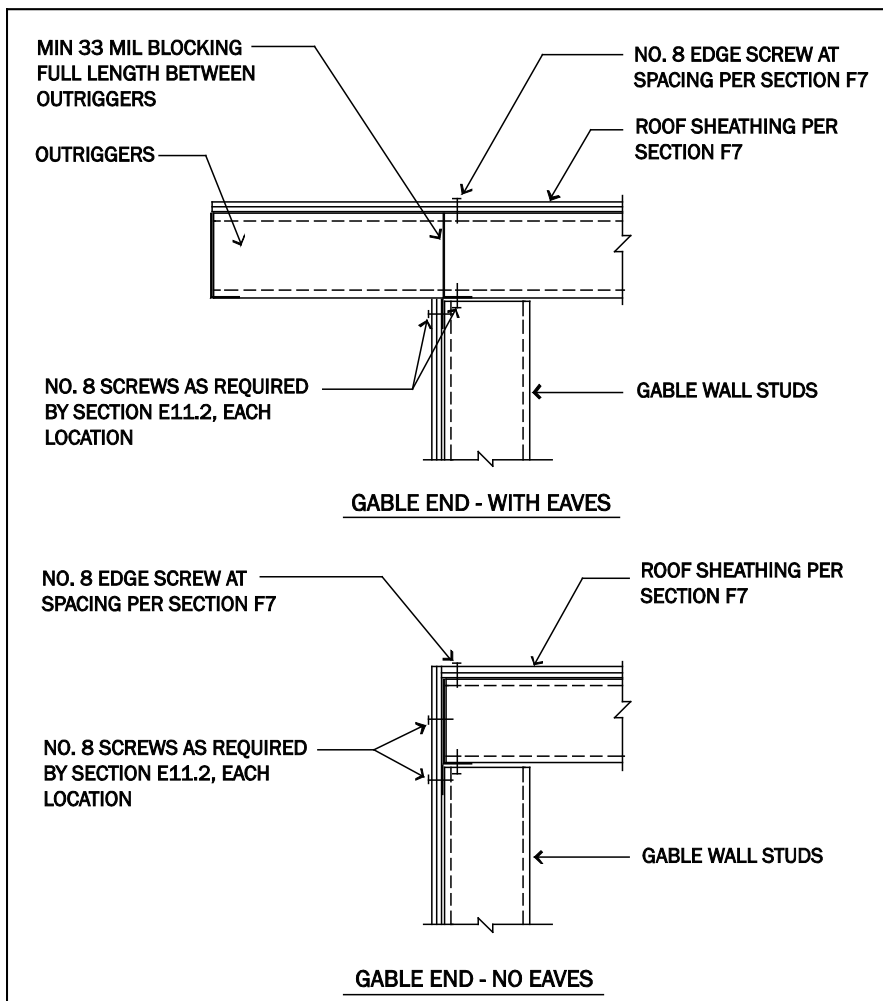

Figure E11-5 Gable Wall Roof Sheathing Attachment to Braced Walls

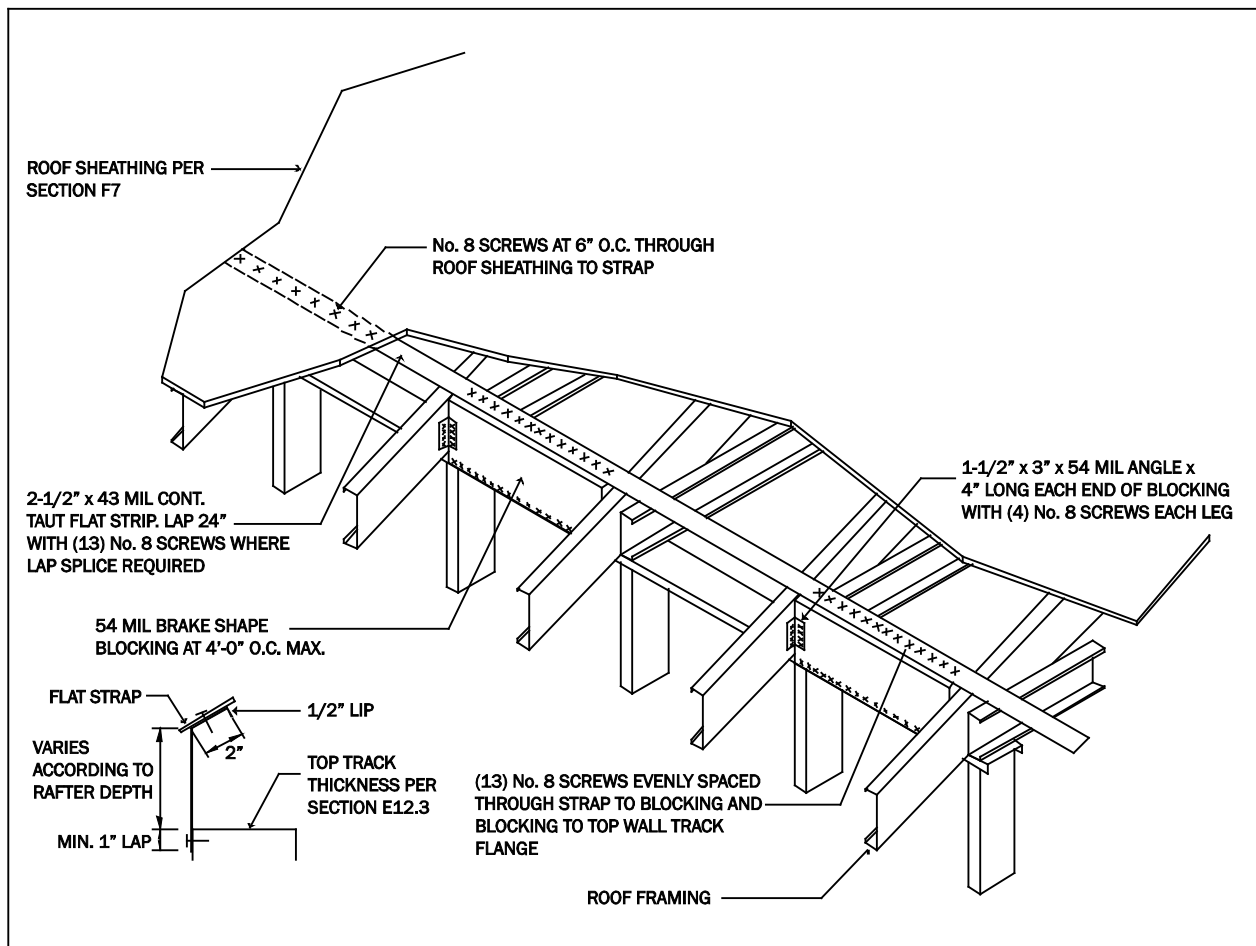

Figure E11-6 Strap and Blocking at Roof Eave

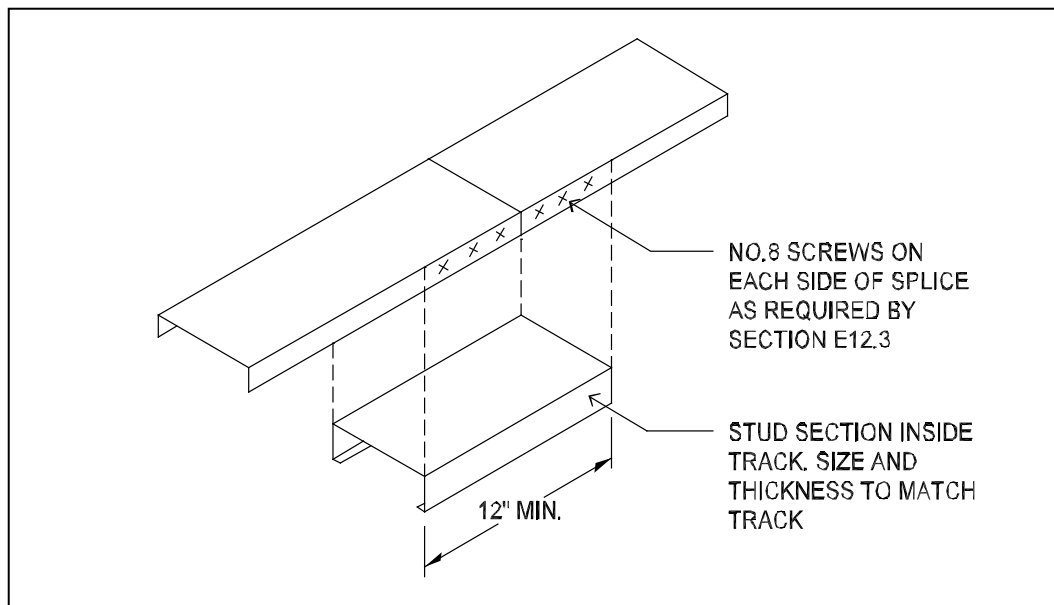

Figure E11-7 Top Track Splice

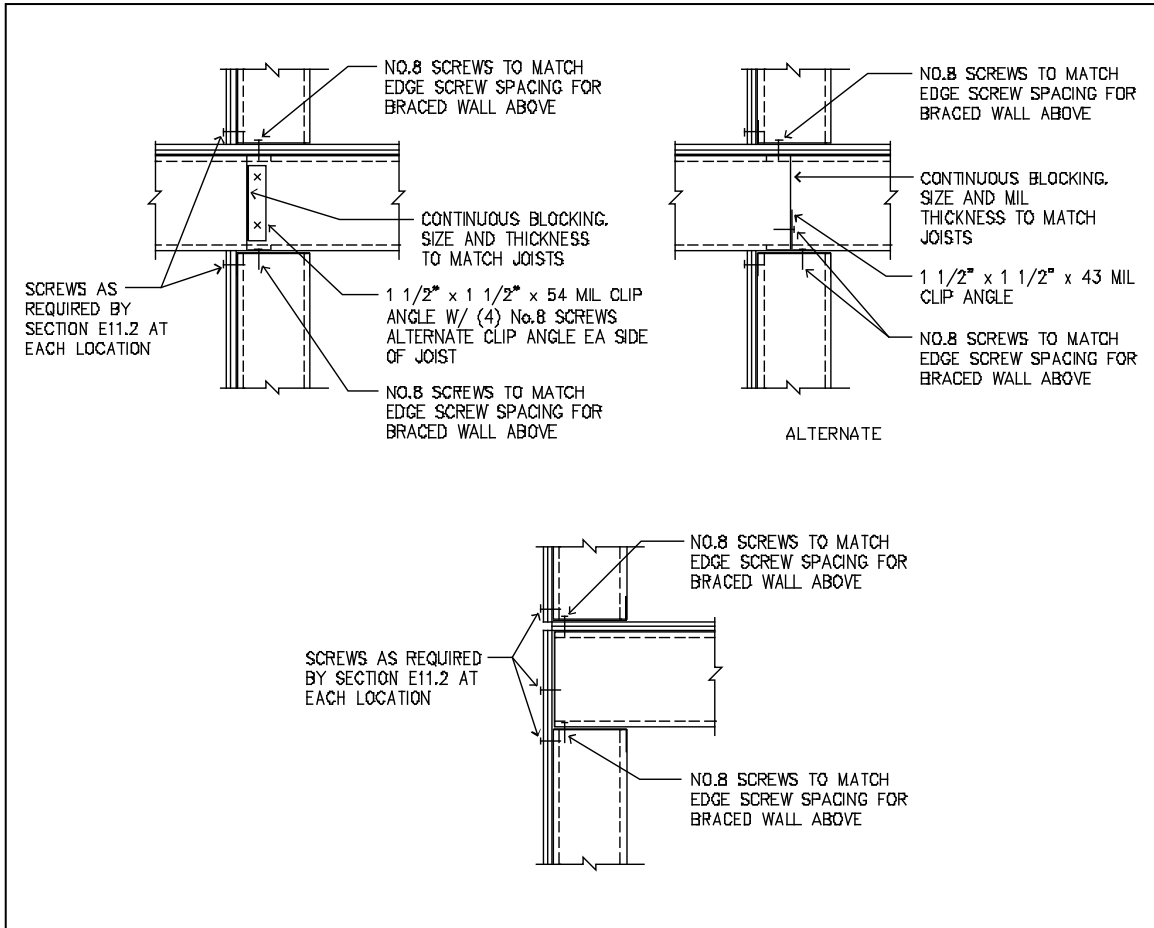

Figure E11-8 Floor Diaphragm Attachment to Braced Walls

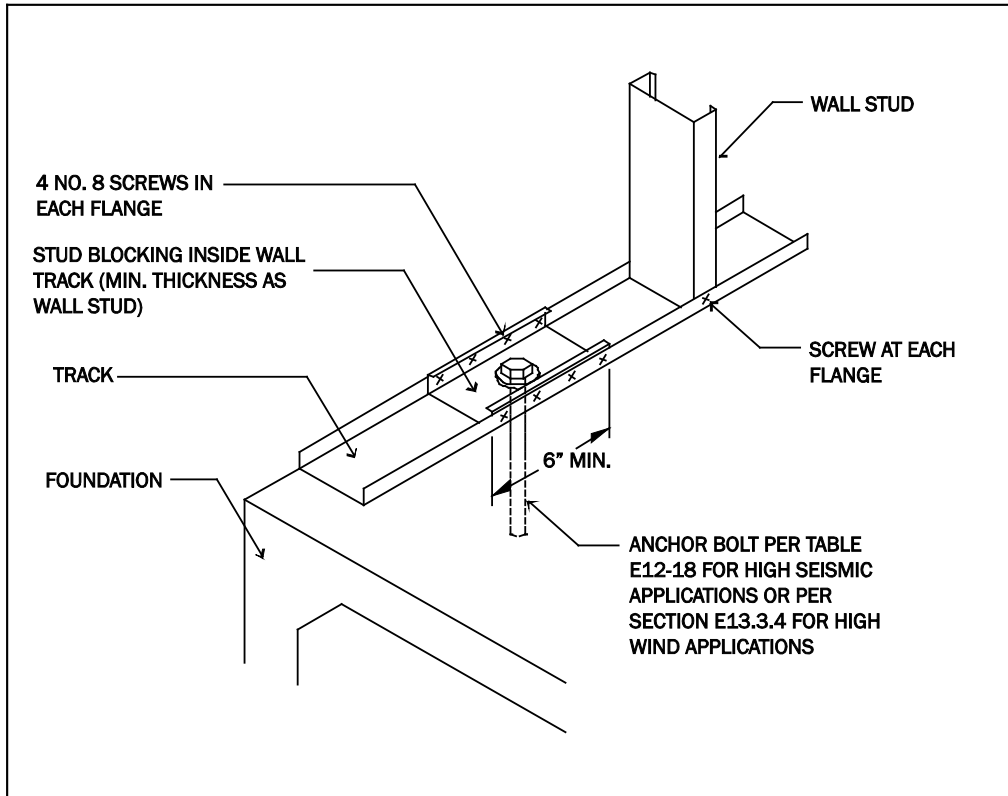

Figure E11-9 Braced Wall to Foundation Connection

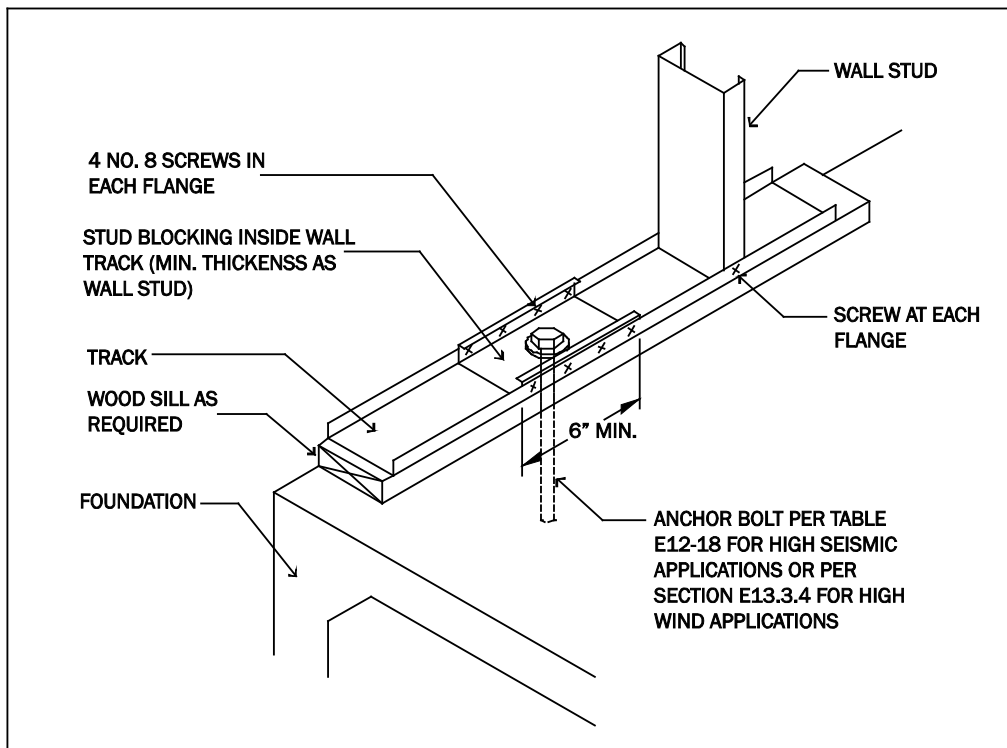

Figure E11-10 Braced Wall to Foundation Connection With Wood Sill

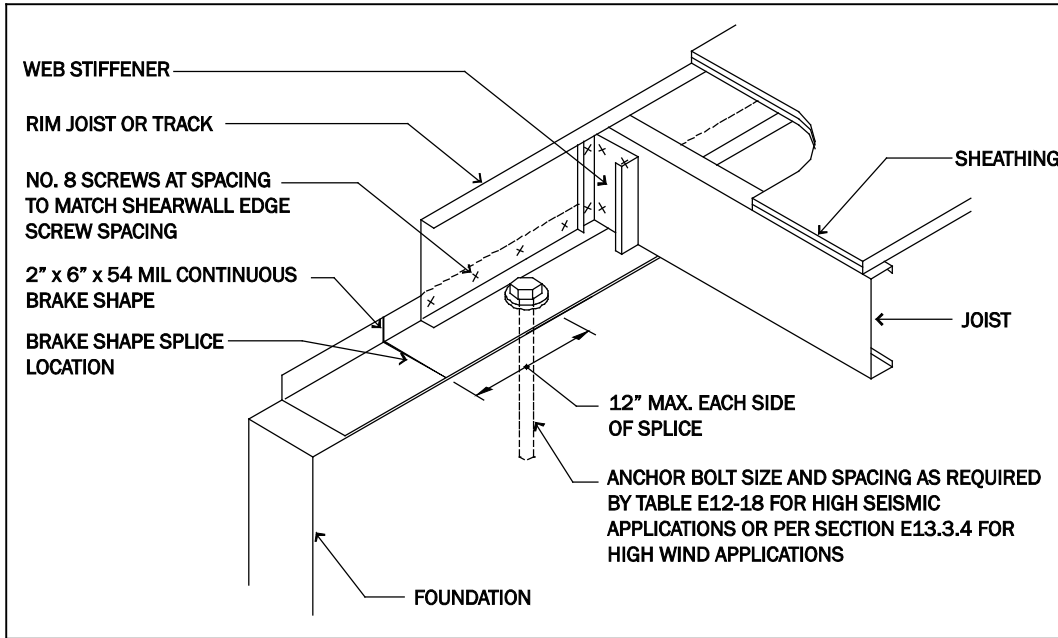

Figure E11-11 Floor to Foundation Connection at Braced Wall

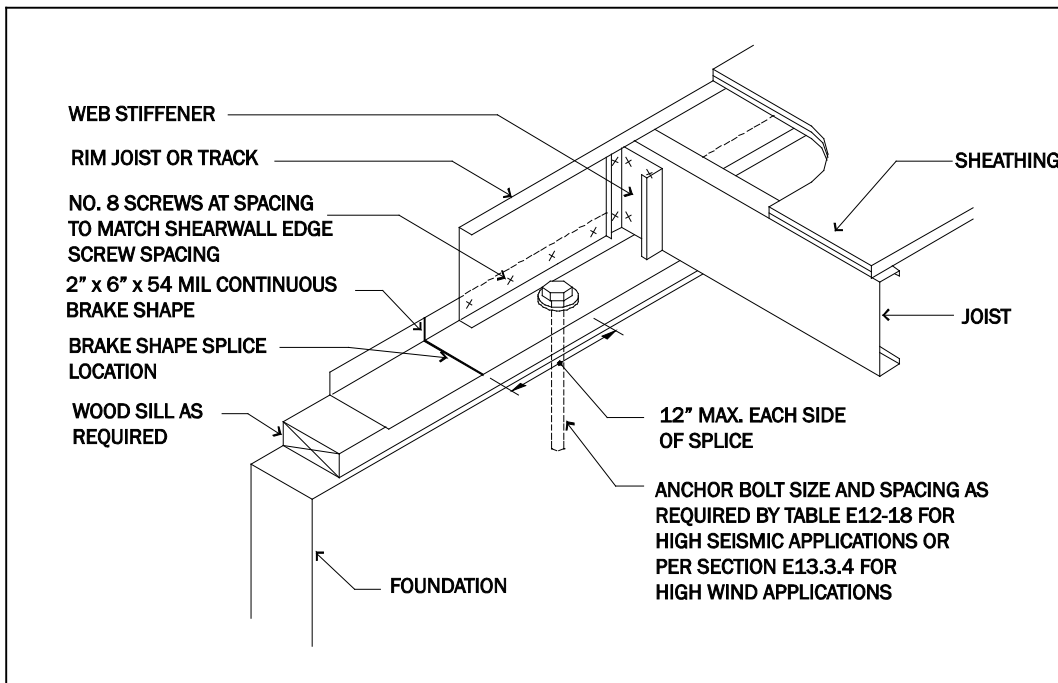

Figure E11-12 Floor to Foundation Connection at Braced Wall With Wood Sill

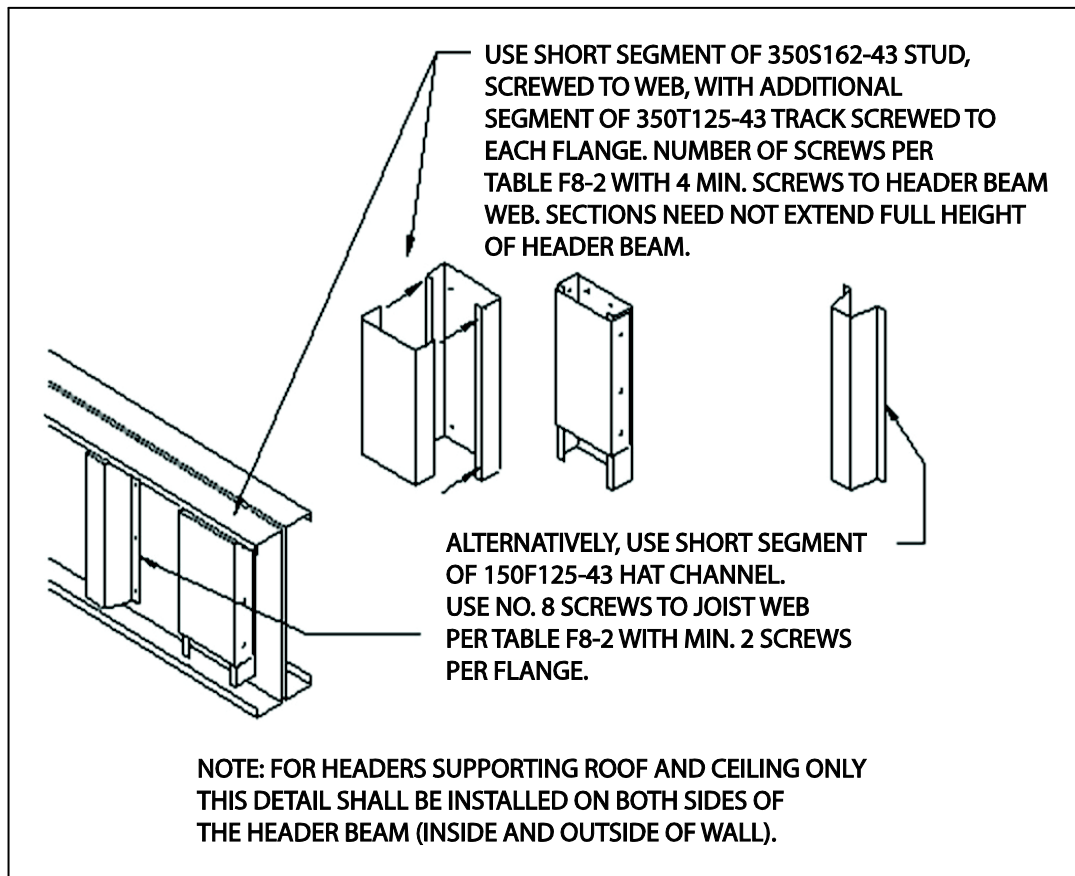

Figure E13-1 Back-to-Back Header Beam Reinforcement for Uplift Strap Connection

Table E2-1
Wall to Foundation or Floor Connection Requirements ¹

Framing Condition			Wind Speed (mph), Exposure, & Seismic Design Category ²					
			115B SDC A,B,C	120B	130B 115C	140B 120 C	130 C	< 140 C
Wall bottom <i>track</i> to floor per Figure E2-4			1-No. 8 screw at 12" o.c.	1-No. 8 screw at 8" o.c.	2-No. 8 screws at 8" o.c.	2-No. 8 screws at 6" o.c.	3-No. 8 screws at 8" o.c.	3-No. 8 screws at 6" o.c.
Wall bottom <i>track</i> to foundation per Figure E2-1 or E2-2 ⁴			1/2" minimum diameter anchor bolt at 6' o.c.	1/2" minimum diameter anchor bolt at 6' o.c.	1/2" minimum diameter anchor bolt at 4' o.c.	1/2" minimum diameter anchor bolt at 4' o.c.	1/2" minimum diameter anchor bolt at 3'-4" o.c.	1/2" minimum diameter anchor bolt at 2'-8" o.c.
Wall bottom <i>track</i> to wood sill per Figure E2-3			Steel plate spaced at 4' o.c., with 4-No. 8 screws and 4-10d or 6-8d common nails	Steel plate spaced at 4' o.c., with 4-No. 8 screws and 4-10d or 6-8d common nails	Steel plate spaced at 3' o.c., with 4-No. 8 screws and 4-10d or 6-8d common nails	Steel plate spaced at 3' o.c., with 4-No. 8 screws and 4-10d or 6-8d common nails	Steel plate spaced at 2' o.c., with 4-No. 8 screws and 4-10d or 6-8d common nails	Steel plate spaced at 1'-4" o.c., with 4-No. 8 screws and 4-10d or 6-8d common nails
Wind uplift connector strength (lbs) ^{3 5 6}	Stud Spacing (in)	Roof Span (ft)						
			16	24	N/R	N/R	N/R	N/R
	28	N/R		N/R	N/R	N/R	N/R	339
	32	N/R		N/R	N/R	N/R	N/R	382
	36	N/R		N/R	N/R	N/R	333	426
	40	N/R		N/R	N/R	N/R	368	470
	24	24	N/R	N/R	N/R	N/R	343	443
		28	N/R	N/R	N/R	N/R	395	508
		32	N/R	N/R	N/R	330	447	573
		36	N/R	N/R	N/R	371	500	639
40		N/R	N/R	345	411	552	704	

For SI: 1 inch = 25.4 mm, 1 mph = 1.61 km/hr, 1 foot = 0.305 m, 1 lb = 4.45 N

¹ Anchor bolts are to be located not more than 12 inches (305 mm) from corners or the termination of bottom *tracks* (e.g. at door openings or corners). Bolts are to extend a minimum of 15 inches (381 mm) into masonry or 7 inches (178 mm) into concrete.

² SDC indicates *Seismic Design Category*. See Sections E11 through E13 for floor connection requirements in *high seismic areas* and *high wind areas*.

³ N/R = Uplift connector not required.

⁴ Foundation anchor *straps* are permitted, in lieu of anchor bolts, if spaced as required to provide equivalent anchorage to the required anchor bolts and installed in accordance with manufacturer's requirements.

⁵ Refer to Figure E2-5.

⁶ Required connection strengths are nominal values to be used with published strengths expressed as allowable loads.

Table E2-2
Gable Endwall to Floor Connection Requirements ^{1, 2, 3, 4}

Basic Wind Speed (mph)		Wall Bottom Track to Floor Joist or Track Connection		
Exposure		Stud Height, h (ft)		
B	C	10 < h ≤ 14	14 < h ≤ 18	18 < h ≤ 22
115		1-No. 8 screw @ 12" o.c.	1-No. 8 screw @ 12" o.c.	1- No. 8 screw @ 12" o.c.
120		1-No. 8 screw @ 12" o.c.	1-No. 8 screw @ 12" o.c.	1-No. 8 screw @ 12" o.c.
130	115	1-No. 8 screw @ 12" o.c.	1-No. 8 screw @ 12" o.c.	2-No. 8 screws @ 12" o.c.
140	120	1-No. 8 screw @ 12" o.c.	1-No. 8 screw @ 12" o.c.	2-No. 8 screws @ 12" o.c.
150	130	2-No. 8 screws @ 12" o.c.	1-No. 8 screw @ 8" o.c.	2-No. 8 screws @ 8" o.c.
160	140	2-No. 8 screws @ 12" o.c.	1-No. 8 screw @ 8" o.c.	2-No. 8 screws @ 8" o.c.
170	150	2-No. 8 screws @ 12" o.c.	2-No. 8 screws @ 8" o.c.	2-No. 8 screws @ 8" o.c.
180	160	2-No. 8 screws @ 12" o.c.	2-No. 8 screws @ 8" o.c.	2-No. 8 screws @ 8" o.c.
-	170	2-No. 8 screws @ 8" o.c.	2-No. 8 screws @ 8" o.c.	2-No. 8 screws @ 8" o.c.
	180	2-No. 8 screws @ 8" o.c.	2-No. 8 screws @ 8" o.c.	-

For SI: 1 inch = 25.4 mm, 1 mph = 1.61 km/hr, 1 foot = 0.305 m, 1 lb = 4.45 N

¹ Refer to Sections E11 - E13 for additional requirements for high wind and seismic areas.

² Refer to Table E2-3 for gable endwall bottom *track* to foundation connections.

³ Where attachment is not given, special design is required.

⁴ Stud height, h, is measured from wall bottom track to wall top track or brace connection height.

Table E2-3
Gable Endwall Bottom Track to Foundation Connection Requirements ^{1, 2, 3, 4, 7}

Basic Wind Speed (mph)		Minimum Spacing for 1/2" Diameter Anchor Bolts ⁵		
Exposure		Stud Height, h (ft)		
B	C	10 < h ≤ 14	14 < h ≤ 18	18 < h ≤ 22
115		6'-0" o.c.	6'-0" o.c.	6'-0" o.c.
120		6'-0" o.c.	5'-7" o.c.	6'-0" o.c.
130	115	5'-0" o.c.	6'-0" o.c.	6'-0" o.c.
140	120	6'-0" o.c.	5'-6" o.c.	6'-0" o.c.
150	130	5'-3" o.c.	6'-0" o.c.	6'-0" o.c.
160	140	3'-0" o.c.	3'-0" o.c.	3'-0" o.c.
170	150	3'-0" o.c.	3'-0" o.c.	-
180	160	3'-0" o.c.	3'-0" o.c.	-
-	170	3'-0" o.c.	3'-0" o.c.	-
	180	3'-0" o.c.	3'-0" o.c.	-

For SI: 1 inch = 25.4 mm, 1 mph = 1.61 km/hr, 1 foot = 0.305 m, 1 lb = 4.45 N

¹ Refer to Table E2-2 for gable endwall bottom track to *floor joist* or *track* connection connections.

² Where attachment is not given, special design is required.

³ Stud height, h, is measured from wall bottom track to wall top track or brace connection height.

⁴ Anchorage requirements shall also be determined in the foundation design in accordance with Section C1.

⁵ Foundation anchor *straps* are permitted, in lieu of anchor bolts, if spaced as required to provide equivalent anchorage to the required anchor bolts and installed in accordance with manufacturer's requirements.

⁶ Values for 115 mph Exposure B shall apply to Seismic Design Categories A, B and C.

⁷ Values for 140 mph Exposure C and higher are limited to 3'-0". Reference section E13.3.4.

Table E2-4
Required Uplift Strength
Wall Assembly to Foundation or Floor Assembly

		Basic Wind Speed (mph)				
EXPOSURE B		160	170	180		
EXPOSURE C		140	150	160	170	180
Framing Spacing ³ (in.)	Roof Span (ft)	Required Connection Strength ^{1,2} (lbs)				
12	24	222	275	333	394	459
	28	254	315	380	449	523
	32	287	355	427	504	586
	36	319	394	474	559	650
	40	352	434	521	614	713
16	24	295	367	444	526	613
	28	339	420	507	599	697
	32	382	473	569	672	781
	36	426	526	632	746	866
	40	470	579	695	819	951
19.2	24	354	441	533	631	735
	28	406	504	608	719	836
	32	459	567	683	807	938
	36	511	631	759	895	1040
	40	564	694	834	983	1140
24	24	443	551	666	789	919
	28	508	630	760	898	1050
	32	573	709	854	1010	1170
	36	639	788	948	1120	1300
	40	704	868	1040	1230	1430

For SI: 1 inch = 25.4 mm, 1 foot = .305 m, 1 lb = 4.45 N, 1 mph = 1.61 km/hr

¹ Uplift requirements assume a roof/ceiling dead load of 12 psf (0.51 kN/m²).

² Required connection strengths are nominal values to be used with published strengths expressed as allowable loads.

³ The 12-inch (305-mm) and 19.2-inch (488-mm) framing spacing provide options for design, but do not negate the *in-line framing* requirement of Section E.

Table E2-5
Uplift Strap Connection Requirements
Wall Assembly to Foundation or Floor Assembly

		Basic Wind Speed (mph)				
EXPOSURE B		160	170	180		
EXPOSURE C		140	150	160	170	180
Framing Spacing ¹ (in.)	Roof Span (ft)	Number of No. 8 Screws in a 1-1/4 inch by 33 mil Steel Strap in Each Flange of Stud (See Fig. E2-5)				
12	24	1	1	2	2	2
	28	1	1	2	2	2
	32	1	2	2	2	2
	36	1	2	2	2	3
	40	2	2	2	2	3
16	24	1	2	2	2	2
	28	2	2	2	2	3
	32	2	2	2	3	3
	36	2	2	2	3	3
	40	2	2	3	3	3
19.2	24	2	2	2	2	3
	28	2	2	2	3	3
	32	2	2	3	3	3
	36	2	2	3	3	4
	40	2	3	3	3	4
24	24	2	2	3	3	3
	28	2	2	3	3	4
	32	2	3	3	4	4
	36	2	3	3	4	4
	40	3	3	4	4	5

For SI: 1 inch = 25.4 mm, 1 foot = 0.305 m, 1 mph = 1.61 km/hr

¹ The 12-inch (305-mm) and 19.2-inch (488-mm) framing spacing provide options for design, but do not negate the *in-line framing* requirement of Section E.

Table E3-1
Stud Thickness
24-Foot-Wide Building Supporting Roof and Ceiling Only ^{1,2,3,4,5}

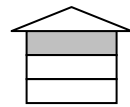

Wind Speed		Member Size	Stud Spacing (inch)	Minimum Stud Thickness (Mils)											
				8-Foot Studs				9-Foot Studs				10-Foot Studs			
Exp. B	Exp. C			Ground Snow Load (psf)											
				20	30	50	70	20	30	50	70	20	30	50	70
115 mph		350S162	16	33	33	33	33	33	33	33	33	33	33	33	33
			24	33	33	33	43	33	33	33	43	33	33	43	43
		550S162	16	33	33	33	33	33	33	33	33	33	33	33	33
			24	33	33	33	33	33	33	33	33	33	33	33	43
120 mph		350S162	16	33	33	33	33	33	33	33	33	33	33	33	33
			24	33	33	33	43	33	33	33	43	43	43	43	43
		550S162	16	33	33	33	33	33	33	33	33	33	33	33	33
			24	33	33	33	43	33	33	33	33	33	33	33	43
130 mph	115 mph	350S162	16	33	33	33	33	33	33	33	33	33	33	33	33
			24	33	33	43	43	43	43	43	43	43	43	43	54
		550S162	16	33	33	33	33	33	33	33	33	33	33	33	33
			24	33	33	33	43	33	33	33	43	33	33	33	43
140 mph	120 mph	350S162	16	33	33	33	33	33	33	33	33	33	33	33	43
			24	33	33	43	43	43	43	43	43	54	54	54	54
		550S162	16	33	33	33	33	33	33	33	33	33	33	33	33
			24	33	33	33	43	33	33	33	43	43	43	43	43
150 mph	130 mph	350S162	16	33	33	33	33	33	33	33	33	43	43	43	43
			24	43	43	43	43	54	54	54	54	54	54	54	54
		550S162	16	33	33	33	33	33	33	33	33	33	33	33	33
			24	33	33	33	43	43	43	43	43	43	43	43	43
160 mph	140 mph	350S162	16	33	33	33	33	43	43	43	43	43	43	43	43
			24	43	43	43	54	54	54	54	54	54	54	54	54
		550S162	16	33	33	33	33	33	33	33	33	33	33	33	33
			24	43	43	43	43	43	43	43	43	43	43	43	43
170 mph	150 mph	350S162	16	33	33	33	33	43	43	43	43	54	54	54	54
			24	54	54	54	54	54	54	54	54	54	54	54	54
		550S162	16	33	33	33	33	33	33	33	33	43	43	43	43
			24	43	43	43	43	43	43	43	43	43	43	43	43
180 mph	160 mph	350S162	16	43	43	43	43	54	54	54	54	54	54	54	54
			24	54	54	54	54	54	54	54	54	68	68	68	68
		550S162	16	43	43	43	43	43	43	43	43	43	43	43	43
			24	43	43	43	43	54	54	54	54	54	54	54	54
180 mph	170 mph	350S162	16	43	43	43	43	54	54	54	54	54	54	54	54
			24	54	54	54	54	54	54	54	54	97	97	97	97
		550S162	16	43	43	43	43	43	43	43	43	43	43	43	43
			24	54	54	54	54	54	54	54	54	54	54	54	54
	180 mph	350S162	16	54	54	54	54	54	54	54	54	54	54	54	54
			24	54	54	54	54	68	68	68	68	97	97	97	97
		550S162	16	43	43	43	43	43	43	43	43	43	43	43	43
			24	54	54	54	54	54	54	54	54	54	54	54	54

For SI: 1 inch = 25.4 mm, 1 mil = 0.0452 mm, 1 psf = 0.0479 kN/m², 1 mph = 1.61 km/hr, 1 foot = 0.305 m

¹ Deflection criteria: L/240

² Design load assumptions:

Second floor dead load is 10 psf (0.48 kN/m²)

Second floor live load is 30 psf (1.44 kN/m²)

Roof/Ceiling dead load is 12 psf (0.58 kN/m²)

³ Building width is in the direction of horizontal framing members supported by the wall studs.

⁴ The minimum yield strength, F_y, of cold-formed steel framing members is 50 ksi (340 MPa) for members with a designation thickness equal to or greater than 54 mils.

⁵ See Section E3 for permitted adjustment to tabulated 43-mil stud thickness.

Table E3-2
Stud Thickness
28-Foot-Wide Building Supporting Roof and Ceiling Only ^{1,2,3,4,5}

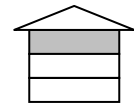

Wind Speed		Member Size	Stud Spacing (inch)	Minimum Stud Thickness (Mils)													
				8-Foot Studs				9-Foot Studs				10-Foot Studs					
Exp. B	Exp. C			Ground Snow Load (psf)													
				20	30	50	70	20	30	50	70	20	30	50	70		
115 mph		350S162	16	33	33	33	33	33	33	33	33	33	33	33	33	33	
			24	33	33	43	43	33	33	43	43	33	33	43	54		
		550S162	16	33	33	33	33	33	33	33	33	33	33	33	33	33	33
			24	33	33	33	43	33	33	33	43	33	33	33	33	43	
120 mph		350S162	16	33	33	33	33	33	33	33	33	33	33	33	33	33	
			24	33	33	43	43	33	33	43	43	43	43	43	54		
		550S162	16	33	33	33	33	33	33	33	33	33	33	33	33	33	
			24	33	33	33	43	33	33	33	43	33	33	33	33	43	
130 mph	115 mph	350S162	16	33	33	33	33	33	33	33	33	33	33	33	33	43	
			24	33	33	43	54	43	43	43	54	43	43	43	54		
		550S162	16	33	33	33	33	33	33	33	33	33	33	33	33	33	
			24	33	33	33	43	33	33	33	43	33	33	33	33	43	
140 mph	120 mph	350S162	16	33	33	33	33	33	33	33	33	33	33	33	33	43	
			24	33	33	43	54	43	43	43	54	54	54	54	54		
		550S162	16	33	33	33	33	33	33	33	33	33	33	33	33	33	
			24	33	33	33	43	33	33	33	43	43	43	43	43		
150 mph	130 mph	350S162	16	33	33	33	33	33	33	33	33	33	33	33	33		
			24	43	43	43	54	54	54	54	54	54	54	54			
		550S162	16	33	33	33	33	33	33	33	33	33	33	33	33		
			24	33	33	33	43	43	43	43	43	43	43	43	43		
160 mph	140 mph	350S162	16	33	33	33	43	43	43	43	43	43	43	43	43		
			24	43	43	43	54	54	54	54	54	54	54	54			
		550S162	16	33	33	33	33	33	33	33	33	33	33	33	33		
			24	43	43	43	43	43	43	43	43	43	43	43	43		
170 mph	150 mph	350S162	16	33	33	33	43	43	43	43	43	54	54	54	54		
			24	54	54	54	54	54	54	54	54	54	54	54			
		550S162	16	33	33	33	33	33	33	33	33	43	43	43	43		
			24	43	43	43	43	43	43	43	43	43	43	43	43		
180 mph	160 mph	350S162	16	43	43	43	43	54	54	54	54	54	54	54	54		
			24	54	54	54	54	54	54	54	54	68	68	68	68		
		550S162	16	43	43	43	43	43	43	43	43	43	43	43	43		
			24	43	43	43	43	54	54	54	54	54	54	54	54		
180 mph	170 mph	350S162	16	43	43	43	43	54	54	54	54	54	54	54	54		
			24	54	54	54	54	54	54	54	54	97	97	97	97		
		550S162	16	43	43	43	43	43	43	43	43	43	43	43	43		
			24	54	54	54	54	54	54	54	54	54	54	54	54		
	180 mph	350S162	16	54	54	54	54	54	54	54	54	54	54	54	54		
			24	54	54	54	54	68	68	68	68	97	97	97	97		
		550S162	16	43	43	43	43	43	43	43	43	43	43	43	43		
			24	54	54	54	54	54	54	54	54	54	54	54	54		

For SI: 1 inch = 25.4 mm, 1 mil = 0.0254 mm, 1 psf = 0.0479 kN/m², 1 mph = 1.61 km/hr, 1 foot = 0.305 m

¹ Deflection criteria: L/240

² Design load assumptions:

Second floor dead load is 10 psf (0.48 kN/m²)

Second floor live load is 30 psf (1.44 kN/m²)

Roof/Ceiling dead load is 12 psf (0.58 kN/m²)

³ Building width is in the direction of horizontal framing members supported by the wall studs.

⁴ The minimum yield strength, F_y , of cold-formed steel framing members is 50 ksi (340 MPa) for members with a designation thickness equal to or greater than 54 mils.

⁵ See Section E3 for permitted adjustment to tabulated 43-mil stud thickness.

Table E3-3
Stud Thickness
32-Foot-Wide Building Supporting Roof and Ceiling Only ^{1,2,3,4,5}

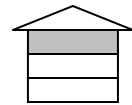

Wind Speed		Member Size	Stud Spacing (inch)	Minimum Stud Thickness (Mils)													
				8-Foot Studs				9-Foot Studs				10-Foot Studs					
Exp. B	Exp. C			Ground Snow Load (psf)													
				20	30	50	70	20	30	50	70	20	30	50	70		
115 mph		350S162	16	33	33	33	33	33	33	33	33	33	33	33	33	43	
			24	33	33	43	54	33	33	43	54	43	43	43	43	43	54
		550S162	16	33	33	33	33	33	33	33	33	33	33	33	33	33	33
			24	33	33	33	43	33	33	33	43	33	33	33	33	33	43
120 mph		350S162	16	33	33	33	33	33	33	33	33	33	33	33	33	43	
			24	33	33	43	54	33	33	43	54	43	43	43	43	54	
		550S162	16	33	33	33	33	33	33	33	33	33	33	33	33	33	33
			24	33	33	33	43	33	33	33	43	33	33	33	33	43	43
130 mph	115 mph	350S162	16	33	33	33	43	33	33	33	43	33	33	33	33	43	
			24	33	33	43	54	43	43	43	54	43	43	54	54		
		550S162	16	33	33	33	33	33	33	33	33	33	33	33	33	33	33
			24	33	33	43	43	33	33	33	43	33	33	33	43	43	43
140 mph	120 mph	350S162	16	33	33	33	43	33	33	33	43	33	33	33	33	43	
			24	33	33	43	54	43	43	43	54	54	54	54	54		
		550S162	16	33	33	33	33	33	33	33	33	33	33	33	33	33	33
			24	33	33	43	43	33	33	33	43	43	43	43	43	43	43
150 mph	130 mph	350S162	16	33	33	33	43	33	33	33	43	43	43	43	43	43	
			24	43	43	43	54	54	54	54	54	54	54	54	54		
		550S162	16	33	33	33	33	33	33	33	33	33	33	33	33	33	33
			24	33	33	43	43	43	43	43	43	43	43	43	43	43	43
160 mph	140 mph	350S162	16	33	33	33	43	43	43	43	43	43	43	43	43	43	
			24	43	43	54	54	54	54	54	54	54	54	54	54		
		550S162	16	33	33	33	33	33	33	33	33	33	33	33	33	33	33
			24	43	43	43	43	43	43	43	43	43	43	43	43	43	43
170 mph	150 mph	350S162	16	33	33	33	43	43	43	43	43	54	54	54	54		
			24	54	54	54	54	54	54	54	54	54	54	54	54		
		550S162	16	33	33	33	33	33	33	33	33	43	43	43	43	43	
			24	43	43	43	43	43	43	43	43	43	43	43	43	54	
180 mph	160 mph	350S162	16	43	43	43	43	54	54	54	54	54	54	54	54	54	
			24	54	54	54	54	54	54	54	54	68	68	68	68		
		550S162	16	43	43	43	43	43	43	43	43	43	43	43	43	43	
			24	43	43	43	43	54	54	54	54	54	54	54	54	54	
	170 mph	350S162	16	43	43	43	43	54	54	54	54	54	54	54	54	54	
			24	54	54	54	54	54	54	54	54	97	97	97	97		
		550S162	16	43	43	43	43	43	43	43	43	43	43	43	43	43	
			24	54	54	54	54	54	54	54	54	54	54	54	54	54	
	180 mph	350S162	16	54	54	54	54	54	54	54	54	54	54	54	54	54	
			24	54	54	54	54	68	68	68	68	97	97	97	97		
		550S162	16	43	43	43	43	43	43	43	43	43	43	43	43	43	
			24	54	54	54	54	54	54	54	54	54	54	54	54	54	

For SI: 1 inch = 25.4 mm, 1 mil = 0.0254 mm, 1 psf = 0.0479 kN/m², 1 mph = 1.61 km/hr, 1 foot = 0.305 m

¹ Deflection criteria: L/240

² Design load assumptions:

Second floor dead load is 10 psf (0.48 kN/m²)

Second floor live load is 30 psf (1.44 kN/m²)

Roof/Ceiling dead load is 12 psf (0.58 kN/m²)

³ Building width is in the direction of horizontal framing members supported by the wall studs.

⁴ The minimum yield strength, F_y, of cold-formed steel framing members is 50 ksi (340 MPa) for members with a designation thickness equal to or greater than 54 mils.

⁵ See Section E3 for permitted adjustment to tabulated 43-mil stud thickness.

Table E3-4
Stud Thickness
36-Foot-Wide Building Supporting Roof and Ceiling Only ^{1,2,3,4,5}

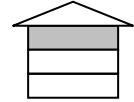

Wind Speed		Member Size	Stud Spacing (inch)	Minimum Stud Thickness (Mils)												
				8-Foot Studs				9-Foot Studs				10-Foot Studs				
Exp. B	Exp. C			Ground Snow Load (psf)												
				20	30	50	70	20	30	50	70	20	30	50	70	
115 mph		350S162	16	33	33	33	43	33	33	33	43	33	33	33	43	
			24	33	33	43	54	33	33	43	54	43	43	54	54	
		550S162	16	33	33	33	33	33	33	33	33	33	33	33	33	33
			24	33	33	43	43	33	33	43	43	33	33	43	43	
120 mph		350S162	16	33	33	33	43	33	33	33	43	33	33	33	43	
			24	33	33	43	54	33	33	43	54	43	43	54	54	
		550S162	16	33	33	33	33	33	33	33	33	33	33	33	33	33
			24	33	33	43	43	33	33	43	43	33	33	43	43	
130 mph	115 mph	350S162	16	33	33	33	43	33	33	33	43	33	33	43	43	
			24	33	43	43	54	43	43	43	54	43	43	54	54	
		550S162	16	33	33	33	33	33	33	33	33	33	33	33	33	33
			24	33	33	43	43	33	33	43	43	33	33	43	43	
140 mph	120 mph	350S162	16	33	33	33	43	33	33	33	43	33	33	43	43	
			24	43	43	43	54	43	43	43	54	54	54	54	54	
		550S162	16	33	33	33	33	33	33	33	33	33	33	33	33	33
			24	33	33	43	43	33	33	43	43	43	43	43	43	54
150 mph	130 mph	350S162	16	33	33	33	43	33	33	33	43	43	43	43	43	
			24	43	43	54	54	54	54	54	54	54	54	54	54	
		550S162	16	33	33	33	33	33	33	33	33	33	33	33	33	43
			24	33	33	43	54	43	43	43	43	43	43	43	43	54
160 mph	140 mph	350S162	16	33	33	33	43	43	43	43	43	43	43	43	54	
			24	43	43	54	54	54	54	54	54	54	54	54	68	
		550S162	16	33	33	33	33	33	33	33	33	33	33	33	33	43
			24	43	43	43	54	43	43	43	43	43	43	43	43	54
170 mph	150 mph	350S162	16	33	33	43	43	43	43	43	43	43	54	54	54	54
			24	54	54	54	54	54	54	54	54	54	54	54	54	68
		550S162	16	33	33	33	43	33	33	33	33	33	43	43	43	43
			24	43	43	43	54	43	43	43	54	43	43	43	43	54
180 mph	160 mph	350S162	16	43	43	43	43	54	54	54	54	54	54	54	54	54
			24	54	54	54	54	54	54	54	54	54	68	68	68	68
		550S162	16	43	43	43	43	43	43	43	43	43	43	43	43	43
			24	43	43	43	54	54	54	54	54	54	54	54	54	54
	170 mph	350S162	16	43	43	43	43	54	54	54	54	54	54	54	54	54
			24	54	54	54	54	54	54	54	54	54	97	97	97	97
		550S162	16	43	43	43	43	43	43	43	43	43	43	43	43	43
			24	54	54	54	54	54	54	54	54	54	54	54	54	54
	180 mph	350S162	16	54	54	54	54	54	54	54	54	54	54	54	54	54
			24	54	54	54	54	54	68	68	68	68	97	97	97	97
		550S162	16	43	43	43	43	43	43	43	43	43	43	43	43	43
			24	54	54	54	54	54	54	54	54	54	54	54	54	54

For SI: 1 inch = 25.4 mm, 1 mil = 0.0254 mm, 1 psf = 0.0479 kN/m², 1 mph = 1.61 km/hr, 1 foot = 0.305 m

¹ Deflection criteria: L/240

² Design load assumptions:

Second floor dead load is 10 psf (0.48 kN/m²)

Second floor live load is 30 psf (1.44 kN/m²)

Roof/Ceiling dead load is 12 psf (0.58 kN/m²)

³ Building width is in the direction of horizontal framing members supported by the wall studs.

⁴ The minimum yield strength, F_y , of cold-formed steel framing members is 50 ksi (340 MPa) for members with a designation thickness equal to or greater than 54 mils.

⁵ See Section E3 for permitted adjustment to tabulated 43-mil stud thickness.

Table E3-5
Stud Thickness
40-Foot-Wide Building Supporting Roof and Ceiling Only ^{1,2,3,4,5}

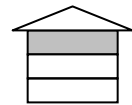

Wind Speed		Member Size	Stud Spacing (inch)	Minimum Stud Thickness (Mils)											
				8-Foot Studs				9-Foot Studs				10-Foot Studs			
Exp. B	Exp. C			Ground Snow Load (psf)											
				20	30	50	70	20	30	50	70	20	30	50	70
115 mph		350S162	16	33	33	33	43	33	33	33	43	33	33	43	43
			24	33	33	43	54	33	43	43	54	43	43	54	54
		550S162	16	33	33	33	43	33	33	33	33	33	33	33	33
			24	33	33	43	54	33	33	43	43	33	33	43	54
120 mph		350S162	16	33	33	33	43	33	33	33	43	33	33	43	43
			24	33	43	43	54	33	43	43	54	43	43	54	54
		550S162	16	33	33	33	43	33	33	33	33	33	33	33	43
			24	33	33	43	54	33	33	43	43	33	33	43	54
130 mph	115 mph	350S162	16	33	33	33	43	33	33	33	43	33	33	43	43
			24	43	43	54	54	43	43	54	54	43	54	54	54
		550S162	16	33	33	33	43	33	33	33	33	33	33	33	43
			24	33	33	43	54	33	33	43	54	33	33	43	54
140 mph	120 mph	350S162	16	33	33	33	43	33	33	33	43	33	33	43	43
			24	43	43	54	54	43	43	54	54	54	54	54	54
		550S162	16	33	33	33	43	33	33	33	33	33	33	33	43
			24	33	33	43	54	33	33	43	54	43	43	43	54
150 mph	130 mph	350S162	16	33	33	43	43	33	33	43	43	43	43	43	54
			24	43	43	54	54	54	54	54	54	54	54	54	68
		550S162	16	33	33	33	43	33	33	33	43	33	33	33	43
			24	33	33	43	54	43	43	43	54	43	43	43	54
160 mph	140 mph	350S162	16	33	33	43	43	43	43	43	43	43	43	43	54
			24	43	43	54	54	54	54	54	54	54	54	54	68
		550S162	16	33	33	33	43	33	33	33	43	33	33	33	43
			24	43	43	43	54	43	43	43	54	43	43	43	54
170 mph	150 mph	350S162	16	33	33	43	43	43	43	43	43	54	54	54	54
			24	54	54	54	54	54	54	54	54	54	54	54	68
		550S162	16	33	33	33	43	33	33	33	43	43	43	43	43
			24	43	43	43	54	43	43	43	54	43	43	43	54
180 mph	160 mph	350S162	16	43	43	43	54	54	54	54	54	54	54	54	54
			24	54	54	54	54	54	54	54	54	68	68	68	68
		550S162	16	43	43	43	43	43	43	43	43	43	43	43	43
			24	43	43	43	54	54	54	54	54	54	54	54	54
	170 mph	350S162	16	43	43	43	54	54	54	54	54	54	54	54	54
			24	54	54	54	68	54	54	54	68	97	97	97	97
		550S162	16	43	43	43	43	43	43	43	43	43	43	43	43
			24	54	54	54	54	54	54	54	54	54	54	54	54
	180 mph	350S162	16	54	54	54	54	54	54	54	54	54	54	54	54
			24	54	54	54	68	68	68	68	68	97	97	97	97
		550S162	16	43	43	43	43	43	43	43	43	43	43	43	43
			24	54	54	54	54	54	54	54	54	54	54	54	54

For SI: 1 inch = 25.4 mm, 1 mil = 0.0254 mm, 1 psf = 0.0479 kN/m², 1 mph = 1.61 km/hr, 1 foot = 0.305 m

¹ Deflection criteria: L/240

² Design load assumptions:

Second floor dead load is 10 psf (0.48 kN/m²)

Second floor live load is 30 psf (1.44 kN/m²)

Roof/Ceiling dead load is 12 psf (0.58 kN/m²)

³ Building width is in the direction of horizontal framing members supported by the wall studs.

⁴ The minimum yield strength, *F_y*, of cold-formed steel framing members is 50 ksi (340 MPa) for members with a designation thickness equal to or greater than 54 mils.

⁵ See Section E3 for permitted adjustment to tabulated 43-mil stud thickness.

Table E3-6
Stud Thickness
24-Foot-Wide Building Supporting One Floor, Roof & Ceiling ^{1,2,3,4,5}

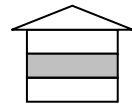

Wind Speed		Member Size	Stud Spacing (inch)	Minimum Stud Thickness (Mils)													
				8-Foot Studs				9-Foot Studs				10-Foot Studs					
Exp. B	Exp. C			Ground Snow Load (psf)													
				20	30	50	70	20	30	50	70	20	30	50	70		
115 mph		350S162	16	33	33	33	33	33	33	33	33	33	33	33	33	43	
			24	33	33	43	43	43	43	43	43	43	43	43	43	54	
		550S162	16	33	33	33	33	33	33	33	33	33	33	33	33	33	33
			24	33	33	33	43	33	33	33	43	33	33	33	33	33	43
120 mph		350S162	16	33	33	33	33	33	33	33	33	33	33	33	33	43	
			24	43	43	43	43	43	43	43	43	43	43	54	54		
		550S162	16	33	33	33	33	33	33	33	33	33	33	33	33	33	33
			24	33	33	33	43	33	33	33	43	33	33	33	33	33	43
130 mph	115 mph	350S162	16	33	33	33	43	33	33	33	43	43	43	43	43	43	
			24	43	43	43	54	43	43	54	54	54	54	54	54	54	
		550S162	16	33	33	33	33	33	33	33	33	33	33	33	33	33	33
			24	33	33	33	43	33	33	33	43	33	33	33	33	33	43
140 mph	120 mph	350S162	16	33	33	33	43	33	33	43	43	43	43	43	43	43	
			24	43	43	43	54	43	54	54	54	54	54	54	54	54	
		550S162	16	33	33	33	33	33	33	33	33	33	33	33	33	33	33
			24	33	33	43	43	33	33	33	43	43	43	43	43	43	43
150 mph	130 mph	350S162	16	33	33	33	43	43	43	43	43	43	43	43	43	54	
			24	43	43	54	54	54	54	54	54	54	54	54	54	54	
		550S162	16	33	33	33	33	33	33	33	33	33	33	33	33	33	33
			24	33	33	43	43	43	43	43	43	43	43	43	43	43	43
160 mph	140 mph	350S162	16	43	43	43	43	43	43	43	43	43	54	54	54	54	
			24	54	54	54	54	54	54	54	54	54	54	54	54	54	
		550S162	16	33	33	33	33	33	33	33	33	33	33	33	33	33	33
			24	43	43	43	43	43	43	43	43	43	43	43	43	43	43
170 mph	150 mph	350S162	16	43	43	43	43	43	43	43	43	54	54	54	54	54	
			24	54	54	54	54	54	54	54	54	54	54	54	68	68	
		550S162	16	33	33	33	33	43	43	43	43	43	43	43	43	43	43
			24	43	43	43	43	43	43	43	43	54	54	54	54	54	54
180 mph	160 mph	350S162	16	43	43	43	43	54	54	54	54	54	54	54	54	54	
			24	54	54	54	54	54	54	54	54	54	54	54	68	68	68
		550S162	16	43	43	43	43	43	43	43	43	43	43	43	43	43	43
			24	43	43	43	43	54	54	54	54	54	54	54	54	54	54
	170 mph	350S162	16	43	43	43	54	54	54	54	54	54	54	54	54	54	
			24	54	54	54	54	54	54	54	54	68	97	97	97	97	
		550S162	16	43	43	43	43	43	43	43	43	43	43	43	43	43	43
			24	54	54	54	54	54	54	54	54	54	54	54	54	54	54
	180 mph	350S162	16	54	54	54	54	54	54	54	54	54	54	54	54	54	54
			24	54	54	54	54	54	68	68	68	68	97	97	97	97	97
		550S162	16	43	43	43	43	43	43	43	43	43	43	43	43	43	43
			24	54	54	54	54	54	54	54	54	54	54	54	54	54	54

For SI: 1 inch = 25.4 mm, 1 mil = 0.0254 mm, 1 psf = 0.0479 kN/m², 1 mph = 1.61 km/hr, 1 foot = 0.305 m

¹ Deflection criteria: L/240

² Design load assumptions:

Second floor dead load is 10 psf (0.48 kN/m²)

Second floor live load is 30 psf (1.44 kN/m²)

Roof/Ceiling dead load is 12 psf (0.58 kN/m²)

³ Building width is in the direction of horizontal framing members supported by the wall studs.

⁴ The minimum yield strength, F_y , of cold-formed steel framing members is 50 ksi (340 MPa) for members with a designation thickness equal to or greater than 54 mils.

⁵ See Section E3 for permitted adjustment to tabulated 43-mil stud thickness.

Table E3-7
Stud Thickness
28-Foot-Wide Building Supporting One Floor, Roof & Ceiling ^{1,2,3,4,5}

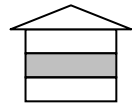

Wind Speed		Member Size	Stud Spacing (inch)	Minimum Stud Thickness (Mils)											
				8-Foot Studs				9-Foot Studs				10-Foot Studs			
Exp. B	Exp. C			Ground Snow Load (psf)											
				20	30	50	70	20	30	50	70	20	30	50	70
115 mph		350S162	16	33	33	33	43	33	33	33	43	33	33	43	43
			24	43	43	43	54	43	43	43	54	43	43	54	54
		550S162	16	33	33	33	33	33	33	33	33	33	33	33	33
			24	33	33	43	43	33	33	43	43	33	33	43	43
120 mph		350S162	16	33	33	33	43	33	33	33	43	33	33	43	43
			24	43	43	43	54	43	43	43	54	54	54	54	54
		550S162	16	33	33	33	33	33	33	33	33	33	33	33	33
			24	33	33	43	43	33	33	43	43	33	33	43	43
130 mph	115 mph	350S162	16	33	33	33	43	33	33	43	43	43	43	43	43
			24	43	43	43	54	43	54	54	54	54	54	54	54
		550S162	16	33	33	33	33	33	33	33	33	33	33	33	33
			24	33	33	43	43	33	33	43	43	43	43	43	43
140 mph	120 mph	350S162	16	33	33	33	43	43	43	43	43	43	43	43	43
			24	43	43	54	54	54	54	54	54	54	54	54	54
		550S162	16	33	33	33	33	33	33	33	33	33	33	33	33
			24	33	33	43	43	33	33	43	43	43	43	43	43
150 mph	130 mph	350S162	16	33	33	43	43	43	43	43	43	43	43	54	54
			24	54	54	54	54	54	54	54	54	54	54	54	54
		550S162	16	33	33	33	33	33	33	33	33	33	33	33	43
			24	33	33	43	43	43	43	43	43	43	43	43	43
160 mph	140 mph	350S162	16	43	43	43	43	43	43	43	43	54	54	54	54
			24	54	54	54	54	54	54	54	54	54	54	54	54
		550S162	16	33	33	33	33	33	33	33	33	33	33	33	43
			24	43	43	43	43	43	43	43	43	43	43	43	54
170 mph	150 mph	350S162	16	43	43	43	43	43	43	54	54	54	54	54	54
			24	54	54	54	54	54	54	54	54	68	68	68	68
		550S162	16	33	33	33	43	43	43	43	43	43	43	43	43
			24	43	43	43	43	43	43	43	43	54	54	54	54
180 mph	160 mph	350S162	16	43	43	43	54	54	54	54	54	54	54	54	54
			24	54	54	54	54	54	54	54	54	68	68	68	68
		550S162	16	43	43	43	43	43	43	43	43	43	43	43	43
			24	43	43	43	54	54	54	54	54	54	54	54	54
	170 mph	350S162	16	43	43	54	54	54	54	54	54	54	54	54	54
			24	54	54	54	54	54	54	68	68	97	97	97	97
		550S162	16	43	43	43	43	43	43	43	43	43	43	43	43
			24	54	54	54	54	54	54	54	54	54	54	54	54
	180 mph	350S162	16	54	54	54	54	54	54	54	54	54	54	54	54
			24	54	54	54	68	68	68	68	68	97	97	97	97
		550S162	16	43	43	43	43	43	43	43	43	43	43	43	43
			24	54	54	54	54	54	54	54	54	54	54	54	54

For SI: 1 inch = 25.4 mm, 1 mil = 0.0254 mm, 1 psf = 0.0479 kN/m², 1 mph = 1.61 km/hr, 1 foot = 0.305 m

1 Deflection criteria: L/240

2 Design load assumptions:

Second floor dead load is 10 psf (0.48 kN/m²)

Second floor live load is 30 psf (1.44 kN/m²)

Roof/Ceiling dead load is 12 psf (0.58 kN/m²)

3 Building width is in the direction of horizontal framing members supported by the wall studs.

4 The minimum yield strength, F_y, of cold-formed steel framing members is 50 ksi (340 MPa) for members with a designation thickness equal to or greater than 54 mils.

5 See Section E3 for permitted adjustment to tabulated 43-mil stud thickness.

**Table E3-8
Stud Thickness**

32-Foot-Wide Building Supporting One Floor, Roof & Ceiling ^{1,2,3,4,5}

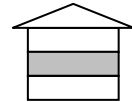

Wind Speed		Member Size	Stud Spacing (inch)	Minimum Stud Thickness (Mils)											
				8-Foot Studs				9-Foot Studs				10-Foot Studs			
Exp. B	Exp. C			Ground Snow Load (psf)											
				20	30	50	70	20	30	50	70	20	30	50	70
115 mph		350S162	16	33	33	33	43	33	33	33	43	33	43	43	43
			24	43	43	43	54	43	43	43	54	54	54	54	54
		550S162	16	33	33	33	43	33	33	33	33	33	33	33	43
			24	33	43	43	54	33	33	43	43	33	33	43	43
120 mph		350S162	16	33	33	33	43	33	33	33	43	43	43	43	43
			24	43	43	43	54	43	43	43	54	54	54	54	54
		550S162	16	33	33	33	43	33	33	33	33	33	33	33	43
			24	33	43	43	54	33	33	43	43	33	33	43	54
130 mph	115 mph	350S162	16	33	33	43	43	43	43	43	43	43	43	43	43
			24	43	43	54	54	54	54	54	54	54	54	54	54
		550S162	16	33	33	33	43	33	33	33	33	33	33	33	43
			24	33	43	43	54	33	33	43	43	43	43	43	54
140 mph	120 mph	350S162	16	33	33	43	43	43	43	43	43	43	43	43	54
			24	43	54	54	54	54	54	54	54	54	54	54	54
		550S162	16	33	33	33	43	33	33	33	43	33	33	33	43
			24	33	43	43	54	33	43	43	43	43	43	43	54
150 mph	130 mph	350S162	16	43	43	43	43	43	43	43	43	43	54	54	54
			24	54	54	54	54	54	54	54	54	54	54	54	54
		550S162	16	33	33	33	43	33	33	33	43	33	33	33	43
			24	43	43	43	54	43	43	43	54	43	43	43	54
160 mph	140 mph	350S162	16	43	43	43	43	43	43	43	54	54	54	54	54
			24	54	54	54	54	54	54	54	54	54	54	54	68
		550S162	16	33	33	33	43	33	33	33	43	33	33	33	43
			24	43	43	43	54	43	43	43	54	43	43	43	54
170 mph	150 mph	350S162	16	43	43	43	43	43	54	54	54	54	54	54	54
			24	54	54	54	54	54	54	54	54	68	68	68	68
		550S162	16	33	33	33	43	43	43	43	43	43	43	43	43
			24	43	43	43	54	43	43	43	54	54	54	54	54
180 mph	160 mph	350S162	16	43	43	54	54	54	54	54	54	54	54	54	54
			24	54	54	54	54	54	54	54	68	68	68	68	68
		550S162	16	43	43	43	43	43	43	43	43	43	43	43	43
			24	43	43	43	54	54	54	54	54	54	54	54	54
	170 mph	350S162	16	54	54	54	54	54	54	54	54	54	54	54	54
			24	54	54	54	54	68	68	68	68	97	97	97	97
		550S162	16	43	43	43	43	43	43	43	43	43	43	43	43
			24	54	54	54	54	54	54	54	54	54	54	54	54
	180 mph	350S162	16	54	54	54	54	54	54	54	54	54	54	54	54
			24	54	54	68	68	68	68	68	68	97	97	97	97
		550S162	16	43	43	43	43	43	43	43	43	43	43	43	43
			24	54	54	54	54	54	54	54	54	54	54	54	54

For SI: 1 inch = 25.4 mm, 1 mil = 0.0254 mm, 1 psf = 0.0479 kN/m², 1 mph = 1.61 km/hr, 1 foot = 0.305 m

¹ Deflection criteria: L/240

² Design load assumptions:

Second floor dead load is 10 psf (0.48 kN/m²)

Second floor live load is 30 psf (1.44 kN/m²)

Roof/Ceiling dead load is 12 psf (0.58 kN/m²)

³ Building width is in the direction of horizontal framing members supported by the wall studs.

⁴ The minimum yield strength, F_y , of cold-formed steel framing members is 50 ksi (340 MPa) for members with a designation thickness equal to or greater than 54 mils.

⁵ See Section E3 for permitted adjustment to tabulated 43-mil stud thickness.

**Table E3-9
Stud Thickness
36-Foot-Wide Building Supporting One Floor, Roof & Ceiling^{1,2,3,4,5}**

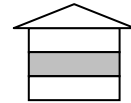

Wind Speed		Member Size	Stud Spacing (inch)	Minimum Stud Thickness (Mils)											
				8-Foot Studs				9-Foot Studs				10-Foot Studs			
Exp. B	Exp. C			Ground Snow Load (psf)											
				20	30	50	70	20	30	50	70	20	30	50	70
115 mph		350S162	16	33	33	43	43	33	33	43	43	43	43	43	43
			24	43	43	54	54	43	43	54	54	54	54	54	54
		550S162	16	33	33	33	43	33	33	33	43	33	33	33	43
			24	43	43	43	54	43	43	43	54	43	43	43	54
120 mph		350S162	16	33	33	43	43	33	33	43	43	43	43	43	43
			24	43	43	54	54	43	43	54	54	54	54	54	54
		550S162	16	33	33	33	43	33	33	33	43	33	33	33	43
			24	43	43	43	54	43	43	43	54	43	43	43	54
130 mph	115 mph	350S162	16	33	33	43	43	43	43	43	43	43	43	43	54
			24	43	54	54	54	54	54	54	54	54	54	54	68
		550S162	16	33	33	33	43	33	33	33	43	33	33	33	43
			24	43	43	43	54	43	43	43	54	43	43	43	54
140 mph	120 mph	350S162	16	43	43	43	43	43	43	43	43	43	43	54	54
			24	54	54	54	54	54	54	54	54	54	54	54	68
		550S162	16	33	33	33	43	33	33	33	43	33	33	33	43
			24	43	43	43	54	43	43	43	54	43	43	43	54
150 mph	130 mph	350S162	16	43	43	43	43	43	43	43	43	54	54	54	54
			24	54	54	54	54	54	54	54	54	54	54	54	68
		550S162	16	33	33	33	43	33	33	33	43	33	33	33	43
			24	43	43	43	54	43	43	43	54	43	43	43	54
160 mph	140 mph	350S162	16	43	43	43	54	43	43	54	54	54	54	54	54
			24	54	54	54	54	54	54	54	54	54	54	54	68
		550S162	16	33	33	33	43	33	33	33	43	33	33	43	43
			24	43	43	43	54	43	43	43	54	43	43	54	54
170 mph	150 mph	350S162	16	43	43	43	54	54	54	54	54	54	54	54	54
			24	54	54	54	68	54	54	54	54	68	68	68	68
		550S162	16	33	33	43	43	43	43	43	43	43	43	43	43
			24	43	43	43	54	43	43	43	54	54	54	54	54
180 mph	160 mph	350S162	16	43	43	54	54	54	54	54	54	54	54	54	54
			24	54	54	54	68	54	54	68	68	68	68	68	68
		550S162	16	43	43	43	43	43	43	43	43	43	43	43	43
			24	43	43	54	54	54	54	54	54	54	54	54	54
	170 mph	350S162	16	54	54	54	54	54	54	54	54	54	54	54	54
			24	54	54	54	68	68	68	68	68	97	97	97	97
		550S162	16	43	43	43	43	43	43	43	43	43	43	43	43
			24	54	54	54	54	54	54	54	54	54	54	54	54
	180 mph	350S162	16	54	54	54	54	54	54	54	54	54	54	54	68
			24	54	68	68	68	68	68	68	68	97	97	97	97
		550S162	16	43	43	43	43	43	43	43	43	43	43	43	43
			24	54	54	54	54	54	54	54	54	54	54	54	54

For SI: 1 inch = 25.4 mm, 1 mil = 0.0254 mm, 1 psf = 0.0479 kN/m², 1 mph = 1.61 km/hr, 1 foot = 0.305 m

¹ Deflection criteria: L/240

² Design load assumptions:

Second floor dead load is 10 psf (0.48 kN/m²)

Second floor live load is 30 psf (1.44 kN/m²)

Roof/Ceiling dead load is 12 psf (0.58 kN/m²)

³ Building width is in the direction of horizontal framing members supported by the wall studs.

⁴ The minimum yield strength, F_y, of cold-formed steel framing members is 50 ksi (340 MPa) for members with a designation thickness equal to or greater than 54 mils.

⁵ See Section E3 for permitted adjustment to tabulated 43-mil stud thickness.

Table E3-10
Stud Thickness
40-Foot-Wide Building Supporting One Floor, Roof & Ceiling ^{1,2,3,4,5}

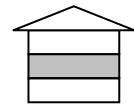

Wind Speed		Member Size	Stud Spacing (inch)	Minimum Stud Thickness (Mils)													
				8-Foot Studs				9-Foot Studs				10-Foot Studs					
Exp. B	Exp. C			Ground Snow Load (psf)													
				20	30	50	70	20	30	50	70	20	30	50	70		
115 mph		350S162	16	33	33	43	43	33	33	43	43	43	43	43	43	54	
			24	43	43	54	54	43	43	54	54	54	54	54	54	68	
		550S162	16	33	33	33	43	33	33	33	43	33	33	33	33	33	43
			24	43	43	54	54	43	43	43	54	43	43	43	43	43	54
120 mph		350S162	16	33	33	43	43	33	33	43	43	43	43	43	43	54	
			24	43	43	54	54	54	54	54	54	54	54	54	54	68	
		550S162	16	33	33	33	43	33	33	33	43	33	33	33	33	43	
			24	43	43	54	54	43	43	43	54	43	43	43	43	54	
130 mph	115 mph	350S162	16	43	43	43	54	43	43	43	43	43	43	43	54	54	
			24	54	54	54	54	54	54	54	54	54	54	54	68		
		550S162	16	33	33	43	43	33	33	33	43	33	33	33	43	43	
			24	43	43	54	54	43	43	43	54	43	43	43	54	54	
140 mph	120 mph	350S162	16	43	43	43	54	43	43	43	54	43	43	54	54		
			24	54	54	54	54	54	54	54	54	54	54	54	68		
		550S162	16	33	33	43	43	33	33	33	43	33	33	43	43		
			24	43	43	54	54	43	43	43	54	43	43	54	54		
150 mph	130 mph	350S162	16	43	43	43	54	43	43	43	54	54	54	54	54		
			24	54	54	54	68	54	54	54	54	54	54	68	68		
		550S162	16	33	33	43	43	33	33	33	43	33	33	43	43		
			24	43	43	54	54	43	43	43	54	43	43	54	54		
160 mph	140 mph	350S162	16	43	43	43	54	43	43	54	54	54	54	54	54		
			24	54	54	54	68	54	54	54	68	54	54	68	68		
		550S162	16	33	33	43	43	33	33	43	43	33	43	43	43		
			24	43	43	54	54	43	43	43	54	43	43	54	54		
170 mph	150 mph	350S162	16	43	43	54	54	54	54	54	54	54	54	54	54		
			24	54	54	54	68	54	54	54	68	68	68	68	68		
		550S162	16	33	33	43	43	43	43	43	43	43	43	43	43		
			24	43	43	54	54	43	43	54	54	54	54	54	54		
180 mph	160 mph	350S162	16	54	54	54	54	54	54	54	54	54	54	54	54		
			24	54	54	54	68	68	68	68	68	68	68	68	97		
		550S162	16	43	43	43	43	43	43	43	43	43	43	43	43		
			24	43	43	54	54	54	54	54	54	54	54	54	54		
	170 mph	350S162	16	54	54	54	54	54	54	54	54	54	54	54	54		
			24	54	54	68	68	68	68	68	68	97	97	97	97		
		550S162	16	43	43	43	43	43	43	43	43	43	43	43	43		
			24	54	54	54	54	54	54	54	54	54	54	54	54		
	180 mph	350S162	16	54	54	54	54	54	54	54	54	54	54	68	68		
			24	68	68	68	68	68	68	68	68	97	97	97	97		
		550S162	16	43	43	43	43	43	43	43	43	54	54	54	54		
			24	54	54	54	54	54	54	54	54	54	54	54	54		

For SI: 1 inch = 25.4 mm, 1 mil = 0.0254 mm, 1 psf = 0.0479 kN/m², 1 mph = 1.61 km/hr, 1 foot = 0.305 m

¹ Deflection criteria: L/240

² Design load assumptions:

Second floor dead load is 10 psf (0.48 kN/m²)

Second floor live load is 30 psf (1.44 kN/m²)

Roof/Ceiling dead load is 12 psf (0.58 kN/m²)

³ Building width is in the direction of horizontal framing members supported by the wall studs.

⁴ The minimum yield strength, F_y , of cold-formed steel framing members is 50 ksi (340 MPa) for members with a designation thickness equal to or greater than 54 mils.

⁵ See Section E3 for permitted adjustment to tabulated 43-mil stud thickness.

Table E3-11
Stud Thickness
24-Foot-Wide Building Supporting Two Floors, Roof & Ceiling ^{1,2,3,4,5}

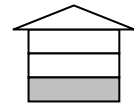

Wind Speed		Member Size	Stud Spacing (inch)	Minimum Stud Thickness (Mils)												
				8-Foot Studs				9-Foot Studs				10-Foot Studs				
Exp. B	Exp. C			Ground Snow Load (psf)												
				20	30	50	70	20	30	50	70	20	30	50	70	
115 mph		350S162	16	43	43	43	43	33	33	33	43	43	43	43	43	43
			24	54	54	54	54	54	54	54	54	54	54	54	54	54
		550S162	16	33	33	43	43	33	33	33	33	33	33	33	33	43
			24	43	43	54	54	43	43	43	43	43	43	43	43	54
120 mph		350S162	16	43	43	43	43	33	33	43	43	43	43	43	43	43
			24	54	54	54	54	54	54	54	54	54	54	54	54	
		550S162	16	33	33	43	43	33	33	33	33	33	33	33	33	43
			24	43	43	54	54	43	43	43	43	43	43	43	43	54
130 mph	115 mph	350S162	16	43	43	43	43	43	43	43	43	43	43	43	43	54
			24	54	54	54	54	54	54	54	54	54	54	54	54	
		550S162	16	33	33	43	43	33	33	33	33	33	33	33	33	43
			24	43	43	54	54	43	43	43	43	43	43	43	43	54
140 mph	120 mph	350S162	16	43	43	43	43	43	43	43	43	43	43	43	54	54
			24	54	54	54	54	54	54	54	54	54	54	54	54	
		550S162	16	33	33	43	43	33	33	33	33	33	33	33	33	43
			24	43	43	54	54	43	43	43	43	43	43	43	43	54
150 mph	130 mph	350S162	16	43	43	43	43	43	43	43	43	54	54	54	54	54
			24	54	54	54	54	54	54	54	54	54	54	68	68	
		550S162	16	33	33	43	43	33	33	33	33	33	33	33	33	43
			24	43	43	54	54	43	43	43	43	43	43	43	43	54
160 mph	140 mph	350S162	16	43	43	43	43	43	43	54	54	54	54	54	54	54
			24	54	54	54	54	54	54	54	54	54	54	68	68	
		550S162	16	33	33	43	43	33	33	33	33	33	33	33	43	43
			24	43	43	54	54	43	43	43	43	54	54	54	54	
170 mph	150 mph	350S162	16	43	43	43	54	54	54	54	54	54	54	54	54	54
			24	54	54	54	54	54	54	54	68	68	68	68	68	
		550S162	16	33	33	43	43	43	43	43	43	43	43	43	43	43
			24	43	43	54	54	43	43	43	43	54	54	54	54	
180 mph	160 mph	350S162	16	54	54	54	54	54	54	54	54	54	54	54	54	54
			24	54	54	54	68	68	68	68	68	68	68	68	68	97
		550S162	16	43	43	43	43	43	43	43	43	43	43	43	43	43
			24	43	43	54	54	54	54	54	54	54	54	54	54	54
	170 mph	350S162	16	54	54	54	54	54	54	54	54	54	54	54	54	54
			24	68	68	68	68	68	68	68	68	97	97	97	97	
		550S162	16	43	43	43	43	43	43	43	43	43	43	43	43	43
			24	54	54	54	54	54	54	54	54	54	54	54	54	54
	180 mph	350S162	16	54	54	54	54	54	54	54	54	54	54	54	54	68
			24	68	68	68	68	68	68	68	68	97	97	97	97	
		550S162	16	43	43	43	43	43	43	43	43	43	43	43	43	43
			24	54	54	54	54	54	54	54	54	54	54	54	54	54

For SI: 1 inch = 25.4 mm, 1 mil = 0.0254 mm, 1 psf = 0.0479 kN/m², 1 mph = 1.61 km/hr, 1 foot = 0.305 m

¹ Deflection criteria: L/240

² Design load assumptions:

Top and middle floor dead load is 10 psf (0.48 kN/m²)

Top floor live load is 30 psf (1.44 kN/m²)

Middle floor live load is 40 psf (1.92 kN/m²)

Roof/Ceiling dead load is 12 psf (0.58 kN/m²)

³ Building width is in the direction of horizontal framing members supported by the wall studs.

⁴ The minimum yield strength, F_y, of cold-formed steel framing members is 50 ksi (340 MPa) for members with a designation thickness equal to or greater than 54 mils.

⁵ See Section E3 for permitted adjustment to tabulated 43-mil stud thickness.

Table E3-12
Stud Thickness
28-Foot-Wide Building Supporting Two Floors, Roof & Ceiling ^{1,2,3,4,5}

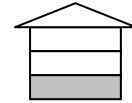

Wind Speed		Member Size	Stud Spacing (inch)	Minimum Stud Thickness (Mils)													
				8-Foot Studs				9-Foot Studs				10-Foot Studs					
Exp. B	Exp. C			Ground Snow Load (psf)													
				20	30	50	70	20	30	50	70	20	30	50	70		
115 mph		350S162	16	43	43	43	43	43	43	43	43	43	43	43	43	43	
			24	54	54	54	54	54	54	54	54	54	54	54	54	54	
		550S162	16	43	43	43	43	43	43	43	43	43	43	43	43	43	43
			24	54	54	54	54	54	54	54	54	54	54	54	54	54	54
120 mph		350S162	16	43	43	43	43	43	43	43	43	43	43	43	43	43	
			24	54	54	54	54	54	54	54	54	54	54	54	54	54	
		550S162	16	43	43	43	43	43	43	43	43	43	43	43	43	43	43
			24	54	54	54	54	54	54	54	54	54	54	54	54	54	54
130 mph	115 mph	350S162	16	43	43	43	43	43	43	43	43	43	43	43	43	43	
			24	54	54	54	54	54	54	54	54	54	54	54	54	54	
		550S162	16	43	43	43	43	43	43	43	43	43	43	43	43	43	43
			24	54	54	54	54	54	54	54	54	54	54	54	54	54	54
140 mph	120 mph	350S162	16	43	43	43	43	43	43	43	43	43	54	54	54	54	
			24	54	54	54	54	54	54	54	54	54	54	54	68	68	
		550S162	16	43	43	43	43	43	43	43	43	43	43	43	43	43	43
			24	54	54	54	54	54	54	54	54	54	54	54	54	54	54
150 mph	130 mph	350S162	16	43	43	43	43	43	43	43	43	54	54	54	54	54	
			24	54	54	54	54	54	54	54	54	54	68	68	68	68	
		550S162	16	43	43	43	43	43	43	43	43	43	43	43	43	43	43
			24	54	54	54	54	54	54	54	54	54	54	54	54	54	54
160 mph	140 mph	350S162	16	43	43	43	54	54	54	54	54	54	54	54	54	54	54
			24	54	54	54	54	54	54	54	54	68	68	68	68	68	68
		550S162	16	43	43	43	43	43	43	43	43	43	43	43	43	43	43
			24	54	54	54	54	54	54	54	54	54	54	54	54	54	54
170 mph	150 mph	350S162	16	43	54	54	54	54	54	54	54	54	54	54	54	54	54
			24	54	54	54	68	68	68	68	68	68	68	68	68	68	68
		550S162	16	43	43	43	43	43	43	43	43	43	43	43	43	43	43
			24	54	54	54	54	54	54	54	54	54	54	54	54	54	54
180 mph	160 mph	350S162	16	54	54	54	54	54	54	54	54	54	54	54	54	54	54
			24	54	68	68	68	68	68	68	68	68	68	68	68	97	97
		550S162	16	43	43	43	43	43	43	43	43	43	43	43	43	43	43
			24	54	54	54	54	54	54	54	54	54	54	54	54	54	54
	170 mph	350S162	16	54	54	54	54	54	54	54	54	54	54	54	54	54	68
			24	68	68	68	68	68	68	68	68	68	97	97	97	97	97
		550S162	16	43	43	43	43	43	43	43	43	43	43	43	43	43	43
			24	54	54	54	54	54	54	54	54	54	54	54	54	54	54
	180 mph	350S162	16	54	54	54	54	54	54	54	54	54	68	68	68	68	68
			24	68	68	68	68	68	68	68	68	68	97	97	97	97	97
		550S162	16	43	43	43	43	43	43	43	43	43	43	43	43	43	54
			24	54	54	54	54	54	54	54	54	54	54	54	54	54	54

For SI: 1 inch = 25.4 mm, 1 mil = 0.0254 mm, 1 psf = 0.0479 kN/m², 1 mph = 1.61 km/hr, 1 foot = 0.305 m

1 Deflection criteria: L/240

2 Design load assumptions:

Top and middle floor dead load is 10 psf (0.48 kN/m²)

Top floor live load is 30 psf (1.44 kN/m²)

Middle floor live load is 40 psf (1.92 kN/m²)

Roof/Ceiling dead load is 12 psf (0.58 kN/m²)

3 Building width is in the direction of horizontal framing members supported by the wall studs.

4 The minimum yield strength, F_y , of cold-formed steel framing members is 50 ksi (340 MPa) for members with a designation thickness equal to or greater than 54 mils.

5 See Section E3 for permitted adjustment to tabulated 43-mil stud thickness.

Table E3-13
Stud Thickness
32-Foot-Wide Building Supporting Two Floors, Roof & Ceiling ^{1,2,3,4,5}

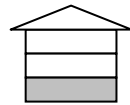

Wind Speed		Member Size	Stud Spacing (inch)	Minimum Stud Thickness (Mils)											
				8-Foot Studs				9-Foot Studs				10-Foot Studs			
Exp. B	Exp. C			Ground Snow Load (psf)											
				20	30	50	70	20	30	50	70	20	30	50	70
115 mph		350S162	16	43	43	43	54	43	43	43	43	43	43	43	54
			24	54	54	54	68	54	54	54	54	54	54	54	68
		550S162	16	43	43	43	43	43	43	43	43	43	43	43	43
			24	54	54	54	54	54	54	54	54	54	54	54	54
120 mph		350S162	16	43	43	43	54	43	43	43	43	43	43	43	54
			24	54	54	54	68	54	54	54	54	54	54	54	68
		550S162	16	43	43	43	43	43	43	43	43	43	43	43	43
			24	54	54	54	54	54	54	54	54	54	54	54	54
130 mph	115 mph	350S162	16	43	43	43	54	43	43	43	43	54	54	54	54
			24	54	54	54	68	54	54	54	54	54	68	68	68
		550S162	16	43	43	43	43	43	43	43	43	43	43	43	43
			24	54	54	54	54	54	54	54	54	54	54	54	54
140 mph	120 mph	350S162	16	43	43	43	54	43	43	43	54	54	54	54	54
			24	54	54	54	68	54	54	54	54	68	68	68	68
		550S162	16	43	43	43	43	43	43	43	43	43	43	43	43
			24	54	54	54	54	54	54	54	54	54	54	54	54
150 mph	130 mph	350S162	16	43	43	43	54	43	54	54	54	54	54	54	54
			24	54	54	54	68	54	54	54	68	68	68	68	68
		550S162	16	43	43	43	43	43	43	43	43	43	43	43	43
			24	54	54	54	54	54	54	54	54	54	54	54	54
160 mph	140 mph	350S162	16	43	43	54	54	54	54	54	54	54	54	54	54
			24	54	54	54	68	54	68	68	68	68	68	68	68
		550S162	16	43	43	43	43	43	43	43	43	43	43	43	43
			24	54	54	54	54	54	54	54	54	54	54	54	54
170 mph	150 mph	350S162	16	54	54	54	54	54	54	54	54	54	54	54	54
			24	54	68	68	68	68	68	68	68	68	68	97	97
		550S162	16	43	43	43	43	43	43	43	43	43	43	43	43
			24	54	54	54	54	54	54	54	54	54	54	54	54
180 mph	160 mph	350S162	16	54	54	54	54	54	54	54	54	54	54	54	54
			24	68	68	68	68	68	68	68	68	97	97	97	97
		550S162	16	43	43	43	43	43	43	43	43	43	43	43	43
			24	54	54	54	54	54	54	54	54	54	54	54	54
	170 mph	350S162	16	54	54	54	54	54	54	54	54	54	54	68	68
			24	68	68	68	68	68	68	68	68	97	97	97	97
		550S162	16	43	43	43	43	43	43	43	43	43	43	43	43
			24	54	54	54	54	54	54	54	54	54	54	54	54
	180 mph	350S162	16	54	54	54	54	54	54	54	54	68	68	68	68
			24	68	68	68	97	68	68	97	97	97	97	97	97
		550S162	16	43	43	43	43	43	43	43	43	43	43	54	54
			24	54	54	54	54	54	54	54	54	54	54	54	54

For SI: 1 inch = 25.4 mm, 1 mil = 0.0254 mm, 1 psf = 0.0479 kN/m², 1 mph = 1.61 km/hr, 1 foot = 0.305 m

1 Deflection criteria: L/240

2 Design load assumptions:

Top and middle floor dead load is 10 psf (0.48 kN/m²)

Top floor live load is 30 psf (1.44 kN/m²)

Middle floor live load is 40 psf (1.92 kN/m²)

Roof/Ceiling dead load is 12 psf (0.58 kN/m²)

3 Building width is in the direction of horizontal framing members supported by the wall studs.

4 The minimum yield strength, F_y , of cold-formed steel framing members is 50 ksi (340 MPa) for members with a designation thickness equal to or greater than 54 mils.

5 See Section E3 for permitted adjustment to tabulated 43-mil stud thickness.

Table E3-14
Stud Thickness
36-Foot-Wide Building Supporting Two Floors, Roof & Ceiling ^{1,2,3,4,5}

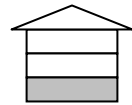

Wind Speed		Member Size	Stud Spacing (inch)	Minimum Stud Thickness (Mils)											
				8-Foot Studs				9-Foot Studs				10-Foot Studs			
Exp. B	Exp. C			Ground Snow Load (psf)											
				20	30	50	70	20	30	50	70	20	30	50	70
115 mph		350S162	16	54	54	54	54	43	43	43	54	54	54	54	54
			24	68	68	68	68	54	54	54	68	68	68	68	68
		550S162	16	43	43	43	54	43	43	43	43	43	43	43	43
			24	54	54	54	54	54	54	54	54	54	54	54	54
120 mph		350S162	16	54	54	54	54	43	43	43	54	54	54	54	54
			24	68	68	68	68	54	54	54	68	68	68	68	68
		550S162	16	43	43	43	54	43	43	43	43	43	43	43	43
			24	54	54	54	54	54	54	54	54	54	54	54	54
130 mph	115 mph	350S162	16	54	54	54	54	43	43	43	54	54	54	54	54
			24	68	68	68	68	54	54	54	68	68	68	68	68
		550S162	16	43	43	43	54	43	43	43	43	43	43	43	43
			24	54	54	54	54	54	54	54	54	54	54	54	54
140 mph	120 mph	350S162	16	54	54	54	54	43	43	54	54	54	54	54	54
			24	68	68	68	68	54	54	54	68	68	68	68	68
		550S162	16	43	43	43	54	43	43	43	43	43	43	43	43
			24	54	54	54	54	54	54	54	54	54	54	54	54
150 mph	130 mph	350S162	16	54	54	54	54	54	54	54	54	54	54	54	54
			24	68	68	68	68	54	54	68	68	68	68	68	68
		550S162	16	43	43	43	54	43	43	43	43	43	43	43	43
			24	54	54	54	54	54	54	54	54	54	54	54	54
160 mph	140 mph	350S162	16	54	54	54	54	54	54	54	54	54	54	54	54
			24	68	68	68	68	68	68	68	68	68	68	68	68
		550S162	16	43	43	43	54	43	43	43	43	43	43	43	43
			24	54	54	54	54	54	54	54	54	54	54	54	54
170 mph	150 mph	350S162	16	54	54	54	54	54	54	54	54	54	54	54	54
			24	68	68	68	68	68	68	68	68	97	97	97	97
		550S162	16	43	43	43	54	43	43	43	43	43	43	43	43
			24	54	54	54	54	54	54	54	54	54	54	54	54
180 mph	160 mph	350S162	16	54	54	54	54	54	54	54	54	54	54	54	68
			24	68	68	68	68	68	68	68	68	97	97	97	97
		550S162	16	43	43	43	54	43	43	43	43	43	43	43	54
			24	54	54	54	54	54	54	54	54	54	54	54	54
	170 mph	350S162	16	54	54	54	54	54	54	54	54	68	68	68	68
			24	68	68	68	97	68	68	68	97	97	97	97	97
		550S162	16	43	43	43	54	43	43	43	43	43	43	54	54
			24	54	54	54	54	54	54	54	54	54	54	54	54
	180 mph	350S162	16	54	54	54	54	54	54	54	54	68	68	68	68
			24	68	68	97	97	97	97	97	97	97	97	97	97
		550S162	16	43	43	43	54	43	43	43	43	54	54	54	54
			24	54	54	54	54	54	54	54	54	54	54	54	54

For SI: 1 inch = 25.4 mm, 1 mil = 0.0254 mm, 1 psf = 0.0479 kN/m², 1 mph = 1.61 km/hr, 1 foot = 0.305 m

¹ Deflection criteria: L/240

² Design load assumptions:

Top and middle floor dead load is 10 psf (0.48 kN/m²)

Top floor live load is 30 psf (1.44 kN/m²)

Middle floor live load is 40 psf (1.92 kN/m²)

Roof/Ceiling dead load is 12 psf (0.58 kN/m²)

³ Building width is in the direction of horizontal framing members supported by the wall studs.

⁴ The minimum yield strength, F_y , of cold-formed steel framing members is 50 ksi (340 MPa) for members with a designation thickness equal to or greater than 54 mils.

⁵ See Section E3 for permitted adjustment to tabulated 43-mil stud thickness.

Table E3-15
Stud Thickness
40-Foot-Wide Building Supporting Two Floors, Roof & Ceiling ^{1,2,3,4,5}

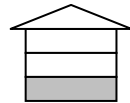

Wind Speed		Member Size	Stud Spacing (inch)	Minimum Stud Thickness (Mils)													
				8-Foot Studs				9-Foot Studs				10-Foot Studs					
Exp. B	Exp. C			Ground Snow Load (psf)													
				20	30	50	70	20	30	50	70	20	30	50	70		
115 mph		350S162	16	54	54	54	54	54	54	54	54	54	54	54	54	54	
			24	68	68	68	68	68	68	68	68	68	68	68	68	68	68
		550S162	16	54	54	54	54	43	43	54	54	43	43	54	54	54	54
			24	54	54	54	68	54	54	54	54	54	54	54	54	54	54
120 mph		350S162	16	54	54	54	54	54	54	54	54	54	54	54	54	54	
			24	68	68	68	68	68	68	68	68	68	68	68	68	68	
		550S162	16	54	54	54	54	43	43	54	54	43	43	54	54	54	
			24	54	54	54	68	54	54	54	54	54	54	54	54	54	54
130 mph	115 mph	350S162	16	54	54	54	54	54	54	54	54	54	54	54	54	54	
			24	68	68	68	68	68	68	68	68	68	68	68	68	68	
		550S162	16	54	54	54	54	43	43	54	54	43	43	54	54	54	
			24	54	54	54	68	54	54	54	54	54	54	54	54	54	54
140 mph	120 mph	350S162	16	54	54	54	54	54	54	54	54	54	54	54	54	54	
			24	68	68	68	68	68	68	68	68	68	68	68	68	68	
		550S162	16	54	54	54	54	43	43	54	54	43	43	54	54	54	
			24	54	54	54	68	54	54	54	54	54	54	54	54	54	54
150 mph	130 mph	350S162	16	54	54	54	54	54	54	54	54	54	54	54	54	54	
			24	68	68	68	68	68	68	68	68	68	68	68	68	97	
		550S162	16	54	54	54	54	43	43	54	54	43	43	54	54	54	
			24	54	54	54	68	54	54	54	54	54	54	54	54	54	54
160 mph	140 mph	350S162	16	54	54	54	54	54	54	54	54	54	54	54	54	54	
			24	68	68	68	68	68	68	68	68	68	68	68	68	97	
		550S162	16	54	54	54	54	43	43	54	54	43	43	54	54	54	
			24	54	54	54	68	54	54	54	54	54	54	54	54	54	54
170 mph	150 mph	350S162	16	54	54	54	54	54	54	54	54	54	54	54	54	68	
			24	68	68	68	68	68	68	68	68	97	97	97	97	97	
		550S162	16	54	54	54	54	43	43	54	54	43	43	54	54	54	
			24	54	54	54	68	54	54	54	54	54	54	54	54	54	54
180 mph	160 mph	350S162	16	54	54	54	54	54	54	54	54	54	68	68	68	68	
			24	68	68	68	97	68	68	68	97	97	97	97	97	97	
		550S162	16	54	54	54	54	43	43	54	54	43	43	54	54	54	
			24	54	54	54	68	54	54	54	54	54	54	54	54	54	54
	170 mph	350S162	16	54	54	54	54	54	54	54	54	54	68	68	68	68	
			24	68	68	97	97	68	68	97	97	97	97	97	97	97	
		550S162	16	54	54	54	54	43	43	54	54	54	54	54	54	54	
			24	54	54	54	68	54	54	54	54	54	54	54	54	54	
	180 mph	350S162	16	54	54	54	54	54	54	54	54	68	68	68	68	68	
			24	97	97	97	97	97	97	97	97	97	97	97	97	97	
		550S162	16	54	54	54	54	43	43	54	54	54	54	54	54	54	
			24	54	54	54	68	54	54	54	54	54	54	54	54	54	

For SI: 1 inch = 25.4 mm, 1 mil = 0.0254 mm, 1 psf = 0.0479 kN/m², 1 mph = 1.61 km/hr, 1 foot = 0.305 m

1 Deflection criteria: L/240

2 Design load assumptions:

Top and middle floor dead load is 10 psf (0.48 kN/m²)

Top floor live load is 30 psf (1.44 kN/m²)

Middle floor live load is 40 psf (1.92 kN/m²)

Roof/Ceiling dead load is 12 psf (0.58 kN/m²)

3 Building width is in the direction of horizontal framing members supported by the wall studs.

4 The minimum yield strength, F_y , of cold-formed steel framing members is 50 ksi (340 MPa) for members with a designation thickness equal to or greater than 54 mils.

5 See Section E3 for permitted adjustment to tabulated 43-mil stud thickness.

Table E3-16
Stud Thickness
All Building Widths
Gable Endwalls 8, 9 or 10 Feet in Height^{1,2,3,4}

Wind Speed		Member Size	Stud Spacing (inch)	Minimum Stud Thickness (Mils)		
Exp. B	Exp. C			8-Foot Studs	9-Foot Studs	10-Foot Studs
115 mph		350S162	16	33	33	33
			24	33	33	33
		550S162	16	33	33	33
			24	33	33	33
120 mph		350S162	16	33	33	33
			24	33	33	43
		550S162	16	33	33	33
			24	33	33	33
130 mph	115 mph	350S162	16	33	33	33
			24	33	43	43
		550S162	16	33	33	33
			24	33	33	33
140 mph	120 mph	350S162	16	33	33	33
			24	33	43	54
		550S162	16	33	33	33
			24	33	33	43
150 mph	130 mph	350S162	16	33	33	43
			24	43	43	54
		550S162	16	33	33	33
			24	33	43	43
160 mph	140 mph	350S162	16	33	43	43
			24	43	54	54
		550S162	16	33	33	33
			24	43	43	43
170 mph	150 mph	350S162	16	43	43	54
			24	54	54	68
		550S162	16	33	33	43
			24	43	43	43
180 mph	160 mph	350S162	16	43	54	54
			24	54	54	68
		550S162	16	43	43	43
			24	43	54	54
	170 mph	350S162	16	43	54	54
			24	54	54	97
		550S162	16	43	43	43
			24	54	54	54
	180 mph	350S162	16	54	54	54
			24	54	68	97
		550S162	16	43	43	43
			24	54	54	54

For SI: 1 inch = 25.4 mm, 1 mil = 0.0254 mm, 1 psf = 0.0479 kN/m², 1 mph = 1.61 km/hr, 1 foot = 0.305 m

¹ Deflection criteria: L/240

² Design load assumptions:

Roof and ceiling dead load is 12 psf (0.58 kN/m²)

Ground snow load is 70 psf (3.35 kN/m²)

Floor dead load is 10 psf (0.48 kN/m²)

Floor live load is 40 psf (1.92 kN/m²)

³ Building width is in the direction of horizontal framing members supported by the wall studs.

⁴ The minimum yield strength, F_y , of cold-formed steel framing members is 50 ksi (340 MPa) for members with a designation thickness equal to or greater than 54 mils.

Table E3-17
Stud Thickness
All Building Widths
Gable Endwalls Over 10 Feet in Height^{1,2,3,4}

Wind Speed		Member Size	Stud Spacing (inch)	Minimum Stud Thickness (Mils)					
Exp. B	Exp. C			Stud Height, h (feet)					
				10 < h ≤ 12	12 < h ≤ 14	14 < h ≤ 16	16 < h ≤ 18	18 < h ≤ 20	20 < h ≤ 22
115 mph		350S162	16	33	43	68	97	-	-
			24	43	68	-	-	-	-
		550S162	16	33	33	33	43	43	54
			24	33	43	43	54	68	97
120 mph		350S162	16	43	54	97	-	-	-
			24	54	97	-	-	-	-
		550S162	16	33	33	43	43	54	68
			24	33	43	54	54	68	97
130 mph	115 mph	350S162	16	43	54	97	-	-	-
			24	54	97	-	-	-	-
		550S162	16	33	33	43	54	54	97
			24	43	43	54	68	97	97
140 mph	120 mph	350S162	16	43	68	-	-	-	-
			24	68	-	-	-	-	-
		550S162	16	33	43	43	54	68	97
			24	43	54	54	68	97	-
150 mph	130 mph	350S162	16	54	97	-	-	-	-
			24	97	-	-	-	-	-
		550S162	16	33	43	54	68	97	-
			24	43	54	54	97	-	-
160 mph	140 mph	350S162	16	54	97	-	-	-	-
			24	97	-	-	-	-	-
		550S162	16	43	43	54	97	97	-
			24	54	54	68	-	-	-
170 mph	150 mph	350S162	16	68	-	-	-	-	-
			24	-	-	-	-	-	-
		550S162	16	43	54	54	97	-	-
			24	54	54	97	-	-	-
180 mph	160 mph	350S162	16	97	-	-	-	-	-
			24	-	-	-	-	-	-
		550S162	16	54	54	68	-	-	-
			24	54	68	97	-	-	-
	170 mph	350S162	16	97	-	-	-	-	-
			24	-	-	-	-	-	-
		550S162	16	54	54	68	-	-	-
			24	54	68	-	-	-	-
	180 mph	350S162	16	-	-	-	-	-	-
			24	-	-	-	-	-	-
		550S162	16	54	54	97	-	-	-
			24	68	97	-	-	-	-

For SI: 1 inch = 25.4 mm, 1 mil = 0.0254 mm, 1 psf = 0.0479 kN/m², 1 mph = 1.61 km/hr, 1 foot = 0.305 m

¹ Deflection criteria: L/240

² Design load assumptions:

Roof/Ceiling dead load is 12 psf (0.58 kN/m²)

³ Ground snow load is 70 psf (3.35 kN/m²).

⁴ The minimum yield strength, F_y , of cold-formed steel framing members is 50 ksi (340 MPa) for members with a designation thickness equal to or greater than 54 mils.

Table E3-18
Wall Fastening Schedule

Connection	Number & Type of Fasteners	Spacing of Fasteners
Stud to top or bottom track	2 No. 8 screws	Each end of stud, one per flange
Structural sheathing (oriented strand board or plywood) to framing	No. 8 screws ¹	Refer to Table E3-19 for screw spacing
1/2" gypsum board to framing	No. 6 screws	12" o.c.

For SI: 1 inch = 25.4 mm

¹ Screws for attachment of structural sheathing panels are to be bugle-head, flat-head, or similar head styles with a minimum head diameter of 0.29 inches (8 mm).

Table E3-19
Minimum Wall Sheathing Attachment for Wind Loads¹

Wind Speed (mph)	Stud Spacing (inches)	Wall Area			
		Interior Zone ²		Corner Zone ³	
		Exposure B	Exposure C	Exposure B	Exposure C
115	16	6/12	6/12	6/12	6/12
	24	6/12	6/12	6/12	6/6
120	16	6/12	6/12	6/12	6/12
	24	6/12	6/12	6/12	6/6
130	16	6/12	6/12	6/12	6/12
	24	6/12	6/12	6/12	6/6
140	16	6/12	6/12	6/12	6/6
	24	6/12	6/12	6/6	6/6
150	16	6/12	6/12	6/12	6/6
	24	6/12	6/6	6/6	6/6
160	16	6/12	6/12	6/12	6/6
	24	6/12	6/6	6/6	4/4
170	16	6/12	6/12	6/6	6/6
	24	6/6	6/6	6/6	4/4
180	16	6/12	6/6	6/6	6/6
	24	6/6	6/6	6/6	4/4

For SI: 1 inch = 25.4 mm, 1 foot = 0.305 m, 1 mph = 1.61 km/hr

¹ Values are for screw spacing in inches at panel edges and in the field (i.e., 6/12 = 6" o.c. edge and 12" o.c. field).

² Interior zone attachment is for sheathing not designated as a corner zone.

³ Corner zone attachment is for sheathing located within 4-feet of building corners on both walls.

Table E7-1
Box-Beam Header Spans
Headers Supporting Roof and Ceiling Only ^{1,2,4}

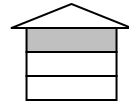

Member Designation	20 psf Ground Snow Load					30 psf Ground Snow Load				
	Building Width ³					Building Width ³				
	24'	28'	32'	36'	40'	24'	28'	32'	36'	40'
2-350S162-33	3'-3"	2'-8"	2'-2"	-	-	2'-8"	2'-2"	-	-	-
2-350S162-43	4'-2"	3'-9"	3'-4"	2'-11"	2'-7"	3'-9"	3'-4"	2'-11"	2'-7"	2'-2"
2-350S162-54	6'-2"	5'-10"	5'-8"	5'-3"	4'-10"	5'-11"	5'-8"	5'-2"	4'-10"	4'-6"
2-350S162-68	6'-7"	6'-3"	6'-0"	5'-10"	5'-8"	6'-4"	6'-1"	5'-10"	5'-8"	5'-6"
2-350S162-97	7'-3"	6'-11"	6'-8"	6'-5"	6'-3"	7'-0"	6'-8"	6'-5"	6'-3"	6'-0"
2-550S162-33	4'-8"	4'-0"	3'-6"	3'-0"	2'-6"	4'-1"	3'-6"	3'-0"	2'-6"	-
2-550S162-43	6'-0"	5'-4"	4'-10"	4'-4"	3'-11"	5'-5"	4'-10"	4'-4"	3'-10"	3'-5"
2-550S162-54	8'-9"	8'-5"	8'-1"	7'-9"	7'-3"	8'-6"	8'-1"	7'-8"	7'-2"	6'-8"
2-550S162-68	9'-5"	9'-0"	8'-8"	8'-4"	8'-1"	9'-1"	8'-8"	8'-4"	8'-1"	7'-10"
2-550S162-97	10'-5"	10'-0"	9'-7"	9'-3"	9'-0"	10'-0"	9'-7"	9'-3"	8'-11"	8'-8"
2-800S162-33	4'-5"	3'-11"	3'-5"	3'-1"	2'-10"	3'-11"	3'-6"	3'-1"	2'-9"	2'-3"
2-800S162-43	7'-3"	6'-7"	5'-11"	5'-4"	4'-10"	6'-7"	5'-11"	5'-4"	4'-9"	4'-3"
2-800S162-54	10'-10"	10'-2"	9'-7"	9'-0"	8'-5"	10'-2"	9'-7"	8'-11"	8'-4"	7'-9"
2-800S162-68	12'-8"	11'-10"	11'-2"	10'-7"	10'-1"	11'-11"	11'-2"	10'-7"	10'-0"	9'-6"
2-800S162-97	14'-2"	13'-6"	13'-0"	12'-7"	12'-2"	13'-8"	13'-1"	12'-7"	12'-2"	11'-9"
2-1000S162-43	7'-10"	6'-10"	6'-1"	5'-6"	5'-0"	6'-11"	6'-1"	5'-5"	4'-11"	4'-6"
2-1000S162-54	12'-3"	11'-5"	10'-9"	10'-2"	9'-6"	11'-6"	10'-9"	10'-1"	9'-5"	8'-9"
2-1000S162-68	14'-5"	13'-5"	12'-8"	12'-0"	11'-6"	13'-6"	12'-8"	12'-0"	11'-5"	10'-10"
2-1000S162-97	17'-1"	16'-4"	15'-8"	14'-11"	14'-3"	16'-5"	15'-9"	14'-10"	14'-1"	13'-6"
2-1200S162-54	12'-11"	11'-3"	10'-0"	9'-0"	8'-2"	11'-5"	10'-0"	9'-0"	8'-1"	7'-4"
2-1200S162-68	15'-11"	14'-10"	14'-0"	13'-4"	12'-8"	15'-0"	14'-0"	13'-3"	12'-7"	11'-11"
2-1200S162-97	19'-11"	18'-7"	17'-6"	16'-8"	15'-10"	18'-9"	17'-7"	16'-7"	15'-9"	15'-0"

For SI: 1 inch = 25.4 mm, 1 mil = 0.0254 mm, 1 psf = 0.0479 kN/m², 1 foot = 0.305 m

¹ Deflection criteria: L/360 for live loads, L/240 for total loads

² Design load assumptions: Roof/Ceiling dead load is 12 psf (0.58 kN/m²)

³ Building width is in the direction of horizontal framing members supported by the header.

⁴ The minimum yield strength, F_y , of cold-formed steel framing members is 50 ksi (340 MPa) for members with a designation thickness equal to or greater than 54 mils.

Table E7-2
Box-Beam Header Spans
Headers Supporting Roof and Ceiling Only ^{1,2,4}

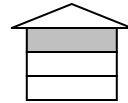

Member Designation	50 psf Ground Snow Load					70 psf Ground Snow Load				
	Building Width ³					Building Width ³				
	24'	28'	32'	36'	40'	24'	28'	32'	36'	40'
2-350S162-33	-	-	-	-	-	-	-	-	-	-
2-350S162-43	2'-4"	-	-	-	-	-	-	-	-	-
2-350S162-54	4'-8"	4'-2"	3'-9"	3'-5"	3'-1"	3'-7"	3'-2"	2'-9"	2'-5"	2'-0"
2-350S162-68	5'-7"	5'-2"	4'-9"	4'-4"	3'-11"	4'-7"	4'-1"	3'-7"	3'-2"	2'-10"
2-350S162-97	6'-2"	5'-11"	5'-8"	5'-6"	5'-4"	5'-8"	5'-5"	5'-3"	4'-11"	4'-7"
2-550S162-33	2'-2"	-	-	-	-	-	-	-	-	-
2-550S162-43	3'-8"	3'-1"	2'-6"	-	-	2'-3"	-	-	-	-
2-550S162-54	6'-11"	6'-3"	5'-9"	5'-3"	4'-9"	5'-6"	4'-11"	4'-5"	3'-11"	3'-5"
2-550S162-68	8'-0"	7'-6"	6'-11"	6'-5"	5'-11"	6'-9"	6'-1"	5'-6"	5'-0"	4'-7"
2-550S162-97	8'-11"	8'-6"	8'-2"	7'-11"	7'-8"	8'-1"	7'-9"	7'-6"	7'-1"	6'-7"
2-800S162-33	2'-7"	-	-	-	-	-	-	-	-	-
2-800S162-43	4'-6"	3'-9"	3'-1"	2'-5"	-	2'-10"	-	-	-	-
2-800S162-54	8'-0"	7'-3"	6'-8"	6'-1"	5'-7"	6'-5"	5'-9"	5'-1"	4'-7"	4'-0"
2-800S162-68	9'-9"	9'-0"	8'-3"	7'-8"	7'-1"	8'-0"	7'-3"	6'-7"	6'-0"	5'-6"
2-800S162-97	12'-1"	11'-7"	11'-2"	10'-8"	10'-2"	11'-0"	10'-4"	9'-9"	9'-2"	8'-7"
2-1000S162-43	4'-8"	4'-1"	3'-6"	2'-9"	-	3'-3"	2'-2"	-	-	-
2-1000S162-54	9'-1"	8'-2"	7'-3"	6'-7"	6'-0"	7'-0"	6'-2"	5'-6"	5'-0"	4'-6"
2-1000S162-68	11'-1"	10'-2"	9'-5"	8'-8"	8'-1"	9'-1"	8'-3"	7'-6"	6'-10"	6'-3"
2-1000S162-97	13'-9"	12'-11"	12'-2"	11'-7"	11'-1"	11'-11"	11'-3"	10'-7"	9'-11"	9'-4"
2-1200S162-54	7'-8"	6'-9"	6'-1"	5'-6"	5'-0"	5'-10"	5'-1"	4'-7"	4'-1"	3'-9"
2-1200S162-68	12'-3"	11'-3"	10'-4"	9'-7"	8'-11"	10'-1"	9'-1"	8'-3"	7'-6"	6'-10"
2-1200S162-97	15'-4"	14'-5"	13'-7"	12'-11"	12'-4"	13'-4"	12'-6"	11'-10"	11'-1"	10'-5"

For SI: 1 inch = 25.4 mm, 1 mil = 0.0254 mm, 1 psf = 0.0479 kN/m², 1 foot = 0.305 m

¹ Deflection criteria: L/360 for live loads, L/240 for total loads

² Design load assumptions: Roof/Ceiling dead load is 12 psf (0.58 kN/m²)

³ Building width is in the direction of horizontal framing members supported by the header.

⁴ The minimum yield strength, F_y , of cold-formed steel framing members is 50 ksi (340 MPa) for members with a designation thickness equal to or greater than 54 mils.

Table E7-3
Box-Beam Header Spans
Headers Supporting One Floor, Roof and Ceiling^{1,2,4}

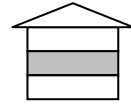

Member Designation	20 psf Ground Snow Load					30 psf Ground Snow Load				
	Building Width ³					Building Width ³				
	24'	28'	32'	36'	40'	24'	28'	32'	36'	40'
2-350S162-33	-	-	-	-	-	-	-	-	-	-
2-350S162-43	2'-2"	-	-	-	-	2'-1"	-	-	-	-
2-350S162-54	4'-4"	3'-10"	3'-5"	3'-1"	2'-9"	4'-3"	2'-9"	3'-4"	3'-0"	2'-8"
2-350S162-68	5'-0"	4'-9"	4'-7"	4'-2"	3'-9"	4'-11"	4'-8"	4'-6"	4'-1"	3'-9"
2-350S162-97	5'-6"	5'-3"	5'-1"	4'-11"	2'-9"	5'-5"	5'-2"	5'-0"	4'-10"	4'-8"
2-550S162-33	-	-	-	-	-	-	-	-	-	-
2-550S162-43	3'-5"	2'-9"	2'-1"	-	-	3'-3"	2'-7"	-	-	-
2-550S162-54	6'-6"	5'-10"	5'-3"	4'-9"	4'-4"	6'-4"	5'-9"	5'-2"	4'-8"	4'-3"
2-550S162-68	7'-2"	6'-10"	6'-5"	5'-11"	5'-6"	7'-0"	6'-9"	6'-4"	5'-10"	5'-4"
2-550S162-97	7'-11"	7'-7"	7'-3"	7'-0"	6'-10"	7'-9"	7'-5"	7'-2"	6'-11"	6'-9"
2-800S162-33	2'-1"	-	-	-	-	-	-	-	-	-
2-800S162-43	4'-2"	3'-4"	2'-7"	-	-	4'-0"	3'-3"	2'-5"	-	-
2-800S162-54	7'-6"	6'-9"	6'-2"	5'-7"	5'-0"	7'-5"	6'-8"	6'-0"	5'-5"	4'-11"
2-800S162-68	9'-3"	8'-5"	7'-8"	7'-1"	6'-6"	9'-1"	8'-3"	7'-7"	7'-0"	6'-5"
2-800S162-97	10'-9"	10'-3"	9'-11"	9'-7"	9'-3"	10'-7"	10'-1"	9'-9"	9'-5"	9'-1"
2-1000S162-43	4'-4"	3'-9"	2'-11"	-	-	4'-3"	3'-8"	2'-9"	-	-
2-1000S162-54	8'-6"	7'-6"	6'-8"	6'-0"	5'-5"	8'-4"	7'-4"	6'-6"	5'-10"	5'-4"
2-1000S162-68	10'-6"	9'-7"	8'-9"	8'-0"	7'-5"	10'-4"	9'-5"	8'-7"	7'-11"	7'-3"
2-1000S162-97	12'-11"	12'-4"	11'-8"	11'-1"	10'-6"	12'-9"	12'-2"	11'-6"	10'-11"	10'-5"
2-1200S162-54	7'-1"	6'-2"	5'-6"	5'-0"	4'-6"	6'-11"	6'-1"	5'-5"	4'-10"	4'-5"
2-1200S162-68	11'-7"	10'-7"	9'-8"	8'-11"	8'-2"	11'-5"	10'-5"	9'-6"	8'-9"	8'-0"
2-1200S162-97	14'-9"	13'-9"	13'-0"	12'-4"	11'-9"	14'-7"	13'-8"	12'-10"	12'-3"	11'-8"

For SI: 1 inch = 25.4 mm, 1 mil = 0.0254 mm, 1 psf = 0.0479 kN/m², 1 foot = 0.305 m

¹ Deflection criteria: L/360 for live loads, L/240 for total loads

² Design load assumptions:

Second floor dead load is 10 psf (0.48 kN/m²)

Roof/Ceiling dead load is 12 psf (0.58 kN/m²)

Second floor live load is 30 psf (1.44 kN/m²)

³ Building width is in the direction of horizontal framing members supported by the header.

⁴ The minimum yield strength, F_y , of cold-formed steel framing members is 50 ksi (340 MPa) for members with a designation thickness equal to or greater than 54 mils.

Table E7-4
Box-Beam Header Spans
Headers Supporting One Floor, Roof and Ceiling^{1,2,4}

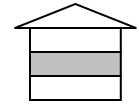

Member Designation	50 psf Ground Snow Load					70 psf Ground Snow Load				
	Building Width ³					Building Width ³				
	24'	28'	32'	36'	40'	24'	28'	32'	36'	40'
2-350S162-33	-	-	-	-	-	-	-	-	-	-
2-350S162-43	-	-	-	-	-	-	-	-	-	-
2-350S162-54	3'-5"	3'-0"	2'-7"	2'-2"	-	2'-8"	2'-2"	-	-	-
2-350S162-68	4'-6"	4'-1"	3'-8"	3'-3"	2'-11"	3'-9"	3'-3"	2'-10"	2'-5"	2'-1"
2-350S162-97	5'-1"	4'-10"	4'-8"	4'-6"	4'-5"	4'-10"	4'-7"	4'-4"	4'-0"	3'-8"
2-550S162-33	-	-	-	-	-	-	-	-	-	-
2-550S162-43	2'-0"	-	-	-	-	-	-	-	-	-
2-550S162-54	5'-3"	3'-8"	4'-1"	3'-8"	3'-2"	4'-3"	3'-8"	3'-1"	2'-7"	2'-0"
2-550S162-68	6'-5"	5'-10"	5'-3"	4'-9"	4'-4"	5'-5"	4'-9"	4'-3"	3'-9"	3'-4"
2-550S162-97	7'-4"	7'-0"	6'-9"	6'-6"	6'-4"	6'-11"	6'-8"	6'-3"	5'-10"	5'-5"
2-800S162-33	-	-	-	-	-	-	-	-	-	-
2-800S162-43	2'-6"	-	-	-	-	-	-	-	-	-
2-800S162-54	6'-1"	5'-5"	4'-10"	4'-3"	3'-9"	4'-11"	4'-3"	3'-8"	3'-0"	2'-5"
2-800S162-68	7'-8"	6'-11"	6'-3"	5'-9"	5'-2"	6'-5"	5'-9"	5'-1"	4'-6"	4'-0"
2-800S162-97	9'-11"	9'-6"	9'-2"	8'-10"	8'-3"	9'-5"	8'-10"	8'-2"	7'-7"	7'-0"
2-1000S162-43	2'-10"	-	-	-	-	-	-	-	-	-
2-1000S162-54	6'-7"	5'-10"	5'-3"	4'-9"	4'-3"	5'-4"	4'-9"	4'-1"	3'-5"	2'-9"
2-1000S162-68	8'-8"	7'-10"	7'-2"	6'-6"	5'-11"	7'-4"	6'-6"	5'-9"	5'-1"	4'-6"
2-1000S162-97	11'-7"	10'-11"	10'-3"	9'-7"	9'-0"	10'-5"	9'-7"	8'-10"	8'-2"	7'-8"
2-1200S162-54	5'-6"	4'-10"	4'-4"	3'-11"	3'-7"	4'-5"	3'-11"	3'-6"	3'-2"	2'-11"
2-1200S162-68	9'-7"	8'-8"	7'-11"	7'-2"	6'-6"	8'-1"	7'-2"	6'-4"	5'-8"	5'-0"
2-1200S162-97	12'-11"	12'-2"	11'-6"	10'-8"	10'-0"	11'-8"	10'-9"	9'-11"	9'-2"	8'-6"

For SI: 1 inch = 25.4 mm, 1 mil = 0.0254 mm, 1 psf = 0.0479 kN/m², 1 foot = 0.305 m

¹ Deflection criteria: L/360 for live loads, L/240 for total loads

² Design load assumptions:

Second floor dead load is 10 psf (0.48 kN/m²)

Roof/Ceiling dead load is 12 psf (0.58 kN/m²)

Second floor live load is 30 psf (1.44 kN/m²)

³ Building width is in the direction of horizontal framing members supported by the header.

⁴ The minimum yield strength, F_y , of cold-formed steel framing members is 50 ksi (340 MPa) for members with a designation thickness equal to or greater than 54 mils.

Table E7-5
Box-Beam Header Spans
Headers Supporting Two Floors, Roof and Ceiling^{1,2,4}

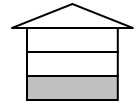

Member Designation	20 psf Ground Snow Load					30 psf Ground Snow Load				
	Building Width ³					Building Width ³				
	24'	28'	32'	36'	40'	24'	28'	32'	36'	40'
2-350S162-33	-	-	-	-	-	-	-	-	-	-
2-350S162-43	-	-	-	-	-	-	-	-	-	-
2-350S162-54	2'-5"	-	-	-	-	2'-4"	-	-	-	-
2-350S162-68	3'-6"	3'-0"	2'-6"	2'-1"	-	3'-5"	2'-11"	2'-6"	2'-0"	-
2-350S162-97	4'-9"	4'-6"	4'-1"	3'-8"	3'-4"	4'-8"	4'-5"	4'-0"	3'-8"	3'-4"
2-550S162-33	-	-	-	-	-	-	-	-	-	-
2-550S162-43	-	-	-	-	-	-	-	-	-	-
2-550S162-54	3'-11"	3'-3"	2'-8"	2'-0"	-	3'-10"	3'-3"	2'-7"	-	-
2-550S162-68	5'-1"	4'-5"	3'-10"	3'-3"	2'-9"	5'-0"	4'-4"	3'-9"	3'-3"	2'-9"
2-550S162-97	6'-10"	6'-5"	5'-10"	5'-5"	4'-11"	6'-9"	6'-4"	5'-10"	5'-4"	4'-11"
2-800S162-33	-	-	-	-	-	-	-	-	-	-
2-800S162-43	-	-	-	-	-	-	-	-	-	-
2-800S162-54	4'-7"	3'-10"	3'-1"	2'-5"	-	4'-6"	3'-9"	3'-0"	2'-4"	-
2-800S162-68	6'-0"	5'-3"	4'-7"	3'-11"	3'-4"	6'-0"	5'-2"	4'-6"	3'-11"	3'-3"
2-800S162-97	9'-2"	8'-4"	7'-8"	7'-0"	6'-6"	9'-1"	8'-3"	7'-7"	7'-0"	6'-5"
2-1000S162-43	-	-	-	-	-	-	-	-	-	-
2-1000S162-54	5'-0"	4'-4"	3'-6"	2'-9"	-	4'-11"	4'-3"	3'-5"	2'-7"	-
2-1000S162-68	6'-10"	6'-0"	5'-3"	4'-6"	3'-10"	6'-9"	5'-11"	5'-2"	4'-5"	3'-9"
2-1000S162-97	10'-0"	9'-1"	8'-3"	7'-8"	7'-0"	9'-10"	9'-0"	8'-3"	7'-7"	7'-0"
2-1200S162-54	4'-2"	3'-7"	3'-3"	2'-11"	-	4'-1"	3'-7"	3'-2"	2'-10"	-
2-1200S162-68	7'-7"	6'-7"	5'-9"	5'-0"	4'-2"	7'-6"	6'-6"	5'-8"	4'-10"	4'-1"
2-1200S162-97	11'-2"	10'-1"	9'-3"	8'-6"	7'-10"	11'-0"	10'-0"	9'-2"	8'-5"	7'-9"

For SI: 1 inch = 25.4 mm, 1 mil = 0.0254 mm, 1 psf = 0.0479 kN/m², 1 foot = 0.305 m

¹ Deflection criteria: L/360 for live loads, L/240 for total loads

² Design load assumptions:

Second and third floor dead load is 10 psf (0.48 kN/m²)

Roof/Ceiling dead load is 12 psf (0.58 kN/m²)

Second floor live load is 40 psf (1.92 kN/m²)

Third floor live load is 30 psf (1.44 kN/m²)

³ Building width is in the direction of horizontal framing members supported by the header.

⁴ The minimum yield strength, F_y , of cold-formed steel framing members is 50 ksi (340 MPa) for members with a designation thickness equal to or greater than 54 mils.

Table E7-6
Box-Beam Header Spans
Headers Supporting Two Floors, Roof and Ceiling^{1,2,4}

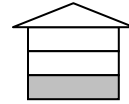

Member Designation	50 psf Ground Snow Load					70 psf Ground Snow Load				
	Building Width ³					Building Width ³				
	24'	28'	32'	36'	40'	24'	28'	32'	36'	40'
2-350S162-33	-	-	-	-	-	-	-	-	-	-
2-350S162-43	-	-	-	-	-	-	-	-	-	-
2-350S162-54	2'-2"	-	-	-	-	-	-	-	-	-
2-350S162-68	3'-3"	2'-9"	2'-3"	-	-	2'-11"	2'-5"	-	-	-
2-350S162-97	4'-6"	4'-3"	3'-10"	3'-6"	3'-2"	4'-3"	4'-0"	3'-7"	3'-3"	3'-0"
2-550S162-33	-	-	-	-	-	-	-	-	-	-
2-550S162-43	-	-	-	-	-	-	-	-	-	-
2-550S162-54	3'-7"	2'-11"	2'-3"	-	-	3'-3"	2'-7"	-	-	-
2-550S162-68	4'-9"	2'-1"	3'-6"	3'-0"	2'-5"	4'-4"	3'-9"	3'-2"	2'-8"	2'-1"
2-550S162-97	6'-5"	6'-1"	5'-7"	5'-1"	4'-8"	6'-3"	5'-10"	5'-4"	4'-10"	4'-5"
2-800S162-33	-	-	-	-	-	-	-	-	-	-
2-800S162-43	-	-	-	-	-	-	-	-	-	-
2-800S162-54	4'-3"	3'-5"	2'-8"	-	-	3'-9"	3'-0"	2'-3"	-	-
2-800S162-68	5'-8"	4'-11"	4'-2"	3'-7"	2'-11"	5'-3"	4'-6"	3'-10"	3'-3"	2'-7"
2-800S162-97	8'-9"	8'-0"	7'-3"	6'-8"	6'-2"	8'-4"	7'-7"	6'-11"	6'-4"	5'-10"
2-1000S162-43	-	-	-	-	-	-	-	-	-	-
2-1000S162-54	4'-8"	3'-11"	3'-1"	2'-2"	-	4'-3"	3'-5"	2'-7"	-	-
2-1000S162-68	6'-5"	5'-7"	4'-9"	4'-1"	3'-4"	5'-11"	5'-1"	4'-5"	3'-8"	2'-11"
2-1000S162-97	9'-6"	8'-8"	7'-11"	7'-3"	6'-8"	9'-0"	8'-3"	7'-6"	6'-11"	6'-4"
2-1200S162-54	3'-11"	3'-5"	3'-0"	2'-4"	-	3'-7"	3'-2"	2'-10"	-	-
2-1200S162-68	7'-1"	6'-2"	5'-3"	4'-6"	3'-8"	6'-6"	5'-8"	4'-10"	4'-0"	3'-3"
2-1200S162-97	10'-8"	9'-8"	8'-10"	8'-1"	7'-5"	10'-1"	9'-2"	8'-5"	7'-9"	7'-1"

For SI: 1 inch = 25.4 mm, 1 mil = 0.0254 mm, 1 psf = 0.0479 kN/m², 1 foot = 0.305 m

¹ Deflection criteria: L/360 for live loads, L/240 for total loads

² Design load assumptions:

Second and third floor dead load is 10 psf (0.48 kN/m²)

Roof/Ceiling dead load is 12 psf (0.58 kN/m²)

Second floor live load is 40 psf (1.92 kN/m²)

Third floor live load is 30 psf (1.44 kN/m²)

³ Building width is in the direction of horizontal framing members supported by the header.

⁴ The minimum yield strength, F_y , of cold-formed steel framing members is 50 ksi (340 MPa) for members with a designation thickness equal to or greater than 54 mils.

Table E7-7
Back-to-Back Header Spans
Headers Supporting Roof and Ceiling Only ^{1,2,4}

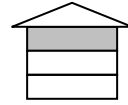

Member Designation	20 psf Ground Snow Load					30 psf Ground Snow Load				
	Building Width ³					Building Width ³				
	24'	28'	32'	36'	40'	24'	28'	32'	36'	40'
2-350S162-33	2'-11"	2'-4"	-	-	-	2'-5"	-	-	-	-
2-350S162-43	4'-8"	3'-10"	3'-5"	3'-1"	2'-9"	3'-11"	3'-5"	3'-0"	2'-8"	2'-4"
2-350S162-54	6'-2"	5'-10"	5'-8"	5'-4"	5'-0"	5'-11"	5'-8"	5'-4"	5'-0"	4'-8"
2-350S162-68	6'-7"	6'-3"	6'-0"	5'-10"	5'-8"	6'-4"	6'-1"	5'-10"	5'-8"	5'-6"
2-350S162-97	7'-3"	6'-11"	6'-8"	6'-5"	6'-3"	7'-0"	6'-8"	6'-5"	6'-3"	6'-0"
2-550S162-33	4'-5"	3'-9"	3'-1"	2'-6"	-	3'-9"	3'-2"	2'-6"	-	-
2-550S162-43	6'-2"	5'-7"	5'-0"	4'-7"	4'-2"	5'-7"	5'-0"	4'-6"	4'-1"	3'-8"
2-550S162-54	8'-9"	8'-5"	8'-1"	7'-9"	7'-5"	8'-6"	8'-1"	7'-9"	7'-5"	6'-11"
2-550S162-68	9'-5"	9'-0"	8'-8"	8'-4"	8'-1"	9'-1"	8'-8"	8'-4"	8'-1"	7'-10"
2-550S162-97	10'-5"	10'-0"	9'-7"	9'-3"	9'-0"	10'-0"	9'-7"	9'-3"	8'-11"	8'-8"
2-800S162-33	4'-5"	3'-11"	3'-5"	3'-1"	2'-4"	3'-11"	3'-6"	3'-0"	2'-3"	-
2-800S162-43	7'-7"	6'-10"	6'-2"	5'-8"	5'-2"	6'-11"	6'-2"	5'-7"	5'-1"	4'-7"
2-800S162-54	10'-10"	10'-2"	9'-7"	9'-1"	8'-8"	10'-2"	9'-7"	9'-0"	8'-7"	8'-1"
2-800S162-68	12'-8"	11'-10"	11'-2"	10'-7"	10'-1"	11'-11"	11'-2"	10'-7"	10'-0"	9'-7"
2-800S162-97	14'-2"	13'-6"	13'-0"	12'-7"	12'-2"	13'-8"	13'-1"	12'-7"	12'-2"	11'-9"
2-1000S162-43	7'-10"	6'-10"	6'-1"	5'-6"	5'-0"	6'-11"	6'-1"	5'-5"	4'-11"	4'-6"
2-1000S162-54	12'-3"	11'-5"	10'-9"	10'-3"	9'-9"	11'-6"	10'-9"	10'-2"	9'-8"	8'-11"
2-1000S162-68	14'-5"	13'-5"	12'-8"	12'-0"	11'-6"	13'-6"	12'-8"	12'-0"	11'-5"	10'-11"
2-1000S162-97	17'-1"	16'-4"	15'-8"	14'-11"	14'-3"	16'-5"	15'-9"	14'-10"	14'-1"	13'-6"
2-1200S162-54	12'-11"	11'-3"	10'-0"	9'-0"	8'-2"	11'-5"	10'-0"	9'-0"	8'-1"	7'-4"
2-1200S162-68	15'-11"	14'-10"	14'-0"	13'-4"	12'-8"	15'-0"	14'-0"	13'-3"	12'-7"	12'-0"
2-1200S162-97	19'-11"	18'-7"	17'-6"	16'-8"	15'-10"	18'-9"	17'-7"	16'-7"	15'-9"	15'-0"

For SI: 1 inch = 25.4 mm, 1 mil = 0.0254 mm, 1 psf = 0.0479 kN/m², 1 foot = 0.305 m

¹ Deflection criteria: L/360 for live loads, L/240 for total loads

² Design load assumptions: Roof/Ceiling dead load is 12 psf (0.58 kN/m²)

³ Building width is in the direction of horizontal framing members supported by the header.

⁴ The minimum yield strength, F_y , of cold-formed steel framing members is 50 ksi (340 MPa) for members with a designation thickness equal to or greater than 54 mils.

Table E7-8
Back-to-Back Header Spans
Headers Supporting Roof and Ceiling Only ^{1,2,4}

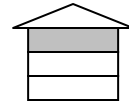

Member Designation	50 psf Ground Snow Load					70 psf Ground Snow Load				
	Building Width ³					Building Width ³				
	24'	28'	32'	36'	40'	24'	28'	32'	36'	40'
2-350S162-33	-	-	-	-	-	-	-	-	-	-
2-350S162-43	2'-6"	-	-	-	-	-	-	-	-	-
2-350S162-54	4'-9"	4'-4"	4'-0"	3'-8"	3'-8"	3'-10"	3'-5"	3'-1"	2'-9"	2'-5"
2-350S162-68	5'-7"	5'-4"	5'-2"	4'-11"	4'-7"	5'-1"	4'-8"	4'-3"	3'-11"	3'-8"
2-350S162-97	6'-2"	5'-11"	5'-8"	5'-6"	5'-4"	5'-8"	5'-5"	5'-3"	5'-0"	4'-11"
2-550S162-33	-	-	-	-	-	-	-	-	-	-
2-550S162-43	3'-10"	3'-3"	2'-9"	2'-2"	-	2'-6"	-	-	-	-
2-550S162-54	7'-2"	6'-6"	6'-0"	5'-7"	5'-2"	5'-10"	5'-3"	4'-10"	4'-5"	4'-0"
2-550S162-68	8'-0"	7'-8"	7'-3"	6'-11"	6'-6"	7'-2"	6'-7"	6'-1"	5'-8"	5'-4"
2-550S162-97	8'-11"	8'-6"	8'-2"	7'-11"	7'-8"	8'-1"	7'-9"	7'-6"	7'-2"	6'-11"
2-800S162-33	-	-	-	-	-	-	-	-	-	-
2-800S162-43	4'-10"	4'-1"	3'-6"	2'-11"	2'-3"	3'-3"	2'-5"	-	-	-
2-800S162-54	8'-4"	7'-8"	7'-1"	6'-7"	6'-1"	6'-10"	6'-3"	5'-8"	5'-2"	4'-9"
2-800S162-68	9'-9"	9'-2"	8'-8"	8'-3"	7'-10"	8'-6"	7'-11"	7'-4"	6'-10"	6'-5"
2-800S162-97	12'-1"	11'-7"	11'-2"	10'-8"	10'-2"	11'-0"	10'-4"	9'-9"	9'-3"	8'-10"
2-1000S162-43	4'-8"	4'-1"	3'-8"	3'-4"	2'-8"	3'-6"	2'-10"	-	-	-
2-1000S162-54	9'-3"	8'-2"	7'-3"	6'-7"	6'-0"	7'-0"	6'-2"	5'-6"	5'-0"	4'-6"
2-1000S162-68	11'-1"	10'-5"	9'-10"	9'-4"	8'-11"	9'-8"	9'-1"	8'-5"	7'-10"	7'-4"
2-1000S162-97	13'-9"	12'-11"	12'-2"	11'-7"	11'-1"	11'-11"	11'-3"	10'-7"	10'-1"	9'-7"
2-1200S162-54	7'-8"	6'-9"	6'-1"	5'-6"	5'-0"	5'-10"	5'-1"	4'-7"	4'-1"	3'-9"
2-1200S162-68	12'-3"	11'-6"	10'-11"	10'-4"	9'-11"	10'-8"	10'-0"	9'-2"	8'-4"	7'-7"
2-1200S162-97	15'-4"	14'-5"	13'-7"	12'-11"	12'-4"	13'-4"	12'-6"	11'-10"	11'-3"	10'-9"

For SI: 1 inch = 25.4 mm, 1 mil = 0.0254 mm, 1 psf = 0.0479 kN/m², 1 foot = 0.305 m

¹ Deflection criteria: L/360 for live loads, L/240 for total loads

² Design load assumptions: Roof/Ceiling dead load is 12 psf (0.58 kN/m²)

³ Building width is in the direction of horizontal framing members supported by the header.

⁴ The minimum yield strength, F_y , of cold-formed steel framing members is 50 ksi (340 MPa) for members with a designation thickness equal to or greater than 54 mils.

Table E7-9
Back-to-Back Header Spans
Headers Supporting One Floor, Roof and Ceiling ^{1,2,4}

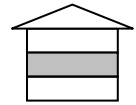

Member Designation	20 psf Ground Snow Load					30 psf Ground Snow Load				
	Building Width ³					Building Width ³				
	24'	28'	32'	36'	40'	24'	28'	32'	36'	40'
2-350S162-33	-	-	-	-	-	-	-	-	-	-
2-350S162-43	2'-2"	-	-	-	-	2'-1"	-	-	-	-
2-350S162-54	4'-6"	4'-1"	3'-8"	3'-4"	3'-0"	4'-5"	4'-0"	3'-7"	3'-3"	2'-11"
2-350S162-68	5'-0"	4'-9"	4'-7"	4'-5"	4'-3"	4'-11"	4'-8"	4'-6"	4'-4"	4'-2"
2-350S162-97	5'-6"	5'-3"	5'-1"	4'-11"	4'-9"	5'-5"	5'-2"	5'-0"	4'-10"	4'-8"
2-550S162-33	-	-	-	-	-	-	-	-	-	-
2-550S162-43	3'-6"	2'-10"	2'-3"	-	-	3'-5"	2'-9"	2'-2"	-	-
2-550S162-54	6'-8"	6'-2"	5'-7"	5'-2"	4'-9"	6'-6"	6'-0"	5'-6"	5'-1"	4'-8"
2-550S162-68	7'-2"	6'-10"	6'-7"	6'-4"	6'-1"	7'-0"	6'-9"	6'-6"	6'-3"	6'-0"
2-550S162-97	7'-11"	7'-7"	7'-3"	7'-0"	6'-10"	7'-9"	7'-5"	7'-2"	6'-11"	6'-9"
2-800S162-33	-	-	-	-	-	-	-	-	-	-
2-800S162-43	4'-4"	3'-8"	2'-11"	2'-3"	-	4'-3"	3'-6"	2'-10"	2'-1"	-
2-800S162-54	7'-11"	7'-2"	6'-7"	6'-1"	5'-7"	7'-9"	7'-1"	6'-6"	6'-0"	5'-6"
2-800S162-68	9'-5"	8'-9"	8'-3"	7'-9"	7'-4"	9'-3"	8'-8"	8'-2"	7'-8"	7'-3"
2-800S162-97	10'-9"	10'-3"	9'-11"	9'-7"	9'-3"	10'-7"	10'-1"	9'-9"	9'-5"	9'-1"
2-1000S162-43	4'-4"	3'-9"	3'-4"	2'-8"	-	4'-3"	3'-8"	3'-3"	2'-6"	-
2-1000S162-54	8'-6"	7'-5"	6'-8"	6'-0"	5'-5"	8'-4"	7'-4"	6'-6"	5'-10"	5'-4"
2-1000S162-68	10'-8"	10'-0"	9'-5"	8'-11"	8'-4"	10'-7"	9'-10"	9'-4"	8'-9"	8'-3"
2-1000S162-97	12'-11"	12'-4"	11'-8"	11'-1"	10'-6"	12'-9"	12'-2"	11'-6"	10'-11"	10'-5"
2-1200S162-54	7'-1"	6'-2"	5'-6"	5'-0"	4'-6"	6'-11"	6'-1"	5'-5"	4'-10"	4'-5"
2-1200S162-68	11'-9"	11'-0"	10'-5"	9'-10"	9'-1"	11'-8"	10'-11"	10'-3"	9'-9"	8'-11"
2-1200S162-97	14'-9"	13'-9"	13'-0"	12'-4"	11'-9"	14'-7"	13'-8"	12'-10"	12'-3"	11'-8"

For SI: 1 inch = 25.4 mm, 1 mil = 0.0254 mm, 1 psf = 0.0479 kN/m², 1 foot = 0.305 m

¹ Deflection criteria: L/360 for live loads, L/240 for total loads

² Design load assumptions:

Second floor dead load is 10 psf (0.48 kN/m²)

Roof/Ceiling dead load is 12 psf (0.58 kN/m²)

Second floor live load is 30 psf (1.44 kN/m²)

³ Building width is in the direction of horizontal framing members supported by the header.

⁴ The minimum yield strength, F_y , of cold-formed steel framing members is 50 ksi (340 MPa) for members with a designation thickness equal to or greater than 54 mils.

Table E7-10
Back-to-Back Header Spans
Headers Supporting One Floor, Roof and Ceiling ^{1,2,4}

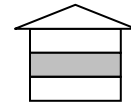

Member Designation	50 psf Ground Snow Load					70 psf Ground Snow Load				
	Building Width ³					Building Width ³				
	24'	28'	32'	36'	40'	24'	28'	32'	36'	40'
2-350S162-33	-	-	-	-	-	-	-	-	-	-
2-350S162-43	-	-	-	-	-	-	-	-	-	-
2-350S162-54	3'-8"	3'-3"	2'-11"	2'-7"	2'-3"	3'-0"	2'-7"	2'-2"	-	-
2-350S162-68	4'-7"	4'-5"	4'-1"	3'-9"	3'-6"	4'-2"	3'-9"	3'-5"	3'-1"	2'-10"
2-350S162-97	5'-1"	4'-10"	4'-8"	4'-6"	4'-5"	4'-10"	4'-7"	4'-5"	4'-3"	4'-1"
2-550S162-33	-	-	-	-	-	-	-	-	-	-
2-550S162-43	2'-2"	-	-	-	-	-	-	-	-	-
2-550S162-54	5'-7"	5'-0"	4'-7"	4'-2"	3'-9"	4'-8"	4'-2"	3'-8"	3'-3"	2'-11"
2-550S162-68	6'-7"	6'-4"	5'-11"	5'-6"	5'-1"	6'-0"	5'-6"	5'-0"	4'-7"	4'-3"
2-550S162-97	7'-4"	7'-0"	6'-9"	6'-6"	6'-4"	6'-11"	6'-8"	6'-5"	6'-2"	6'-0"
2-800S162-33	-	-	-	-	-	-	-	-	-	-
2-800S162-43	2'-11"	2'-0"	-	-	-	-	-	-	-	-
2-800S162-54	6'-7"	5'-11"	5'-5"	4'-11"	4'-6"	5'-6"	4'-11"	4'-5"	3'-11"	3'-6"
2-800S162-68	8'-3"	7'-8"	7'-1"	6'-8"	6'-2"	7'-3"	6'-7"	6'-1"	5'-7"	5'-2"
2-800S162-97	9'-11"	9'-6"	9'-2"	8'-10"	8'-7"	9'-5"	9'-0"	8'-7"	8'-2"	7'-9"
2-1000S162-43	3'-4"	2'-5"	-	-	-	-	-	-	-	-
2-1000S162-54	6'-7"	5'-10"	5'-3"	4'-9"	4'-4"	5'-4"	4'-9"	4'-3"	3'-10"	3'-6"
2-1000S162-68	9'-4"	8'-9"	8'-1"	7'-7"	7'-1"	8'-3"	7'-7"	6'-11"	6'-5"	5'-11"
2-1000S162-97	11'-7"	10'-11"	10'-4"	9'-10"	9'-5"	10'-5"	9'-10"	9'-3"	8'-10"	8'-5"
2-1200S162-54	5'-6"	4'-10"	4'-4"	3'-11"	3'-7"	4'-5"	3'-11"	3'-6"	3'-2"	2'-11"
2-1200S162-68	10'-4"	9'-8"	8'-8"	7'-11"	7'-2"	8'-11"	7'-11"	7'-1"	6'-5"	5'-10"
2-1200S162-97	12'-11"	12'-2"	11'-6"	11'-0"	10'-6"	11'-8"	11'-0"	10'-5"	9'-10"	9'-5"

For SI: 1 inch = 25.4 mm, 1 mil = 0.0254 mm, 1 psf = 0.0479 kN/m², 1 foot = 0.305 m

¹ Deflection criteria: L/360 for live loads, L/240 for total loads

² Design load assumptions:

Second floor dead load is 10 psf (0.48 kN/m²)

Roof/Ceiling dead load is 12 psf (0.58 kN/m²)

Second floor live load is 30 psf (1.44 kN/m²)

³ Building width is in the direction of horizontal framing members supported by the header.

⁴ The minimum yield strength, F_y , of cold-formed steel framing members is 50 ksi (340 MPa) for members with a designation thickness equal to or greater than 54 mils.

Table E7-11
Back-to-Back Header Spans
Headers Supporting Two Floors, Roof and Ceiling^{1,2,4}

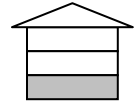

Member Designation	20 psf Ground Snow Load					30 psf Ground Snow Load				
	Building Width ³					Building Width ³				
	24'	28'	32'	36'	40'	24'	28'	32'	36'	40'
2-350S162-33	-	-	-	-	-	-	-	-	-	-
2-350S162-43	-	-	-	-	-	-	-	-	-	-
2-350S162-54	2'-9"	2'-3"	-	-	-	2'-8"	2'-3"	-	-	-
2-350S162-68	3'-11"	3'-6"	3'-2"	2'-10"	2'-6"	3'-11"	3'-6"	3'-1"	2'-9"	2'-6"
2-350S162-97	4'-9"	4'-6"	4'-4"	4'-1"	3'-10"	4'-8"	4'-6"	4'-4"	4'-1"	3'-9"
2-550S162-33	-	-	-	-	-	-	-	-	-	-
2-550S162-43	-	-	-	-	-	-	-	-	-	-
2-550S162-54	4'-5"	3'-10"	3'-4"	2'-11"	2'-5"	4'-4"	3'-9"	3'-3"	2'-10"	2'-5"
2-550S162-68	5'-8"	5'-2"	4'-8"	4'-3"	3'-11"	5'-8"	5'-1"	4'-8"	4'-3"	3'-10"
2-550S162-97	6'-10"	6'-6"	6'-3"	6'-0"	5'-7"	6'-9"	6'-5"	6'-3"	5'-11"	5'-6"
2-800S162-33	-	-	-	-	-	-	-	-	-	-
2-800S162-43	-	-	-	-	-	-	-	-	-	-
2-800S162-54	5'-2"	4'-7"	4'-0"	3'-6"	3'-0"	5'-2"	4'-6"	3'-11"	3'-5"	2'-11"
2-800S162-68	6'-11"	6'-3"	5'-8"	5'-2"	4'-9"	6'-10"	6'-2"	5'-7"	5'-2"	4'-8"
2-800S162-97	9'-3"	8'-8"	8'-3"	7'-9"	7'-4"	9'-2"	8'-8"	8'-2"	7'-9"	7'-4"
2-1000S162-43	-	-	-	-	-	-	-	-	-	-
2-1000S162-54	5'-0"	4'-4"	3'-11"	3'-6"	3'-2"	4'-11"	4'-4"	3'-10"	3'-6"	3'-2"
2-1000S162-68	7'-10"	7'-2"	6'-6"	5'-11"	5'-6"	7'-9"	7'-1"	6'-5"	5'-11"	5'-5"
2-1000S162-97	10'-1"	9'-5"	8'-11"	8'-6"	8'-0"	10'-0"	9'-5"	8'-10"	8'-5"	7'-11"
2-1200S162-54	4'-2"	3'-7"	3'-3"	2'-11"	2'-8"	4'-1"	3'-7"	3'-2"	2'-10"	2'-7"
2-1200S162-68	7'-4"	6'-8"	6'-1"	5'-6"	5'-1"	7'-3"	6'-7"	6'-0"	5'-6"	5'-0"
2-1200S162-97	9'-5"	8'-8"	8'-1"	7'-6"	7'-1"	9'-4"	8'-8"	8'-0"	7'-6"	7'-0"

For SI: 1 inch = 25.4 mm, 1 mil = 0.0254 mm, 1 psf = 0.0479 kN/m², 1 foot = 0.305 m

¹ Deflection criteria: L/360 for live loads, L/240 for total loads

² Design load assumptions:

Second and third floor dead load is 10 psf (0.48 kN/m²)

Roof/Ceiling dead load is 12 psf (0.58 kN/m²)

Second floor live load is 40 psf (1.92 kN/m²)

Third floor live load is 30 psf (1.44 kN/m²)

³ Building width is in the direction of horizontal framing members supported by the header.

⁴ The minimum yield strength, F_y , of cold-formed steel framing members is 50 ksi (340 MPa) for members with a designation thickness equal to or greater than 54 mils.

Table E7-12
Back-to-Back Header Spans
Headers Supporting Two Floors, Roof and Ceiling^{1,2,4}

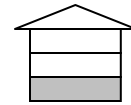

Member Designation	50 psf Ground Snow Load					70 psf Ground Snow Load				
	Building Width ³					Building Width ³				
	24'	28'	32'	36'	40'	24'	28'	32'	36'	40'
2-350S162-33	-	-	-	-	-	-	-	-	-	-
2-350S162-43	-	-	-	-	-	-	-	-	-	-
2-350S162-54	2'-6"	2'-1"	-	-	-	2'-3"	-	-	-	-
2-350S162-68	3'-9"	3'-4"	2'-11"	2'-7"	2'-4"	3'-6"	3'-1"	2'-9"	2'-5"	2'-2"
2-350S162-97	4'-6"	4'-4"	4'-2"	3'-11"	3'-8"	4'-4"	4'-2"	4'-0"	3'-9"	3'-6"
2-550S162-33	-	-	-	-	-	-	-	-	-	-
2-550S162-43	-	-	-	-	-	-	-	-	-	-
2-550S162-54	4'-1"	3'-7"	3'-1"	2'-7"	2'-2"	3'-10"	3'-3"	2'-10"	2'-4"	-
2-550S162-68	5'-5"	4'-11"	4'-5"	4'-0"	3'-8"	5'-1"	4'-7"	4'-2"	3'-10"	3'-5"
2-550S162-97	6'-5"	6'-2"	5'-11"	5'-9"	5'-4"	6'-3"	6'-0"	5'-9"	5'-6"	5'-2"
2-800S162-33	-	-	-	-	-	-	-	-	-	-
2-800S162-43	-	-	-	-	-	-	-	-	-	-
2-800S162-54	4'-11"	4'-3"	3'-8"	3'-2"	2'-8"	4'-6"	3'-11"	3'-5"	2'-11"	2'-4"
2-800S162-68	6'-7"	5'-11"	5'-4"	4'-11"	4'-6"	6'-2"	5'-7"	5'-1"	4'-8"	4'-3"
2-800S162-97	8'-9"	8'-5"	7'-11"	7'-6"	7'-0"	8'-5"	8'-1"	7'-9"	7'-3"	6'-10"
2-1000S162-43	-	-	-	-	-	-	-	-	-	-
2-1000S162-54	4'-8"	4'-1"	3'-8"	3'-3"	3'-0"	4'-4"	3'-10"	3'-5"	3'-1"	2'-9"
2-1000S162-68	7'-6"	6'-9"	6'-2"	5'-8"	5'-2"	7'-1"	6'-5"	5'-10"	5'-4"	4'-11"
2-1000S162-97	9'-9"	9'-2"	8'-7"	8'-2"	7'-8"	9'-5"	8'-10"	8'-5"	7'-11"	7'-5"
2-1200S162-54	3'-11"	3'-5"	3'-0"	2'-9"	2'-6"	3'-7"	3'-2"	2'-10"	2'-7"	2'-4"
2-1200S162-68	7'-0"	6'-4"	5'-9"	5'-3"	4'-9"	6'-7"	6'-0"	5'-5"	5'-0"	4'-6"
2-1200S162-97	9'-1"	8'-4"	7'-9"	7'-3"	6'-9"	8'-8"	8'-0"	7'-6"	7'-0"	6'-7"

For SI: 1 inch = 25.4 mm, 1 mil = 0.0254 mm, 1 psf = 0.0479 kN/m², 1 foot = 0.305 m

¹ Deflection criteria: L/360 for live loads, L/240 for total loads

² Design load assumptions:

Second and third floor dead load is 10 psf (0.48 kN/m²)

Roof/Ceiling dead load is 12 psf (0.58 kN/m²)

Second floor live load is 40 psf (1.92 kN/m²)

Third floor live load is 30 psf (1.44 kN/m²)

³ Building width is in the direction of horizontal framing members supported by the header.

⁴ The minimum yield strength, F_y , of cold-formed steel framing members is 50 ksi (340 MPa) for members with a designation thickness equal to or greater than 54 mils.

Table E7-13
Number of Screws Required for Header to King Stud Connection

Header Span	Basic Wind Speed (mph), Exposure & Seismic Design Categories ^{1,2,3}					
	115 B Seismic Design Category A,B,C	120 B	130 B	140 B	130 C	< 140 C
			115 C	120 C		
< 4'	4-No. 8 screws	4-No. 8 screws	4-No. 8 screws	4-No. 8 screws	6-No. 8 screws	6-No. 8 screws
> 4' to 8'	4-No. 8 screws	4-No. 8 screws	4-No. 8 screws	6-No. 8 screws	8-No. 8 screws	8-No. 8 screws
> 8' to 12'	4-No. 8 screws	6-No. 8 screws	6-No. 8 screws	8-No. 8 screws	10-No. 8 screws	12-No. 8 screws
> 12' to 16'	4-No. 8 screws	6-No. 8 screws	8-No. 8 screws	10-No. 8 screws	12-No. 8 screws	14-No. 8 screws

For SI: 1 foot = 0.305 m, 1 mph = 1.61 km/hr

¹For headers located on the first floor of a two-story building or the first or second floor of a three-story building, the total number of screws is permitted to be reduced by 2 screws, but the total number of screws shall be no less than 4.

²For roof slopes of 6:12 or greater, the required number of screws is permitted to be reduced by 1/2, but the total number of screws shall be no less than 4.

³Screws can be replaced by an uplift connector, which has the strength of the number of screws multiplied by 164 lbs (729 N) (e.g. 12-No. 8 screws can be replaced by an uplift connector whose strength exceeds 12 x 164 lbs = 1,968 lbs).

Table E7-14
Double L-Header Spans – Gravity Loading
Headers Supporting Roof and Ceiling Only ^{1,2,3}

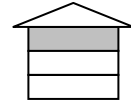

Double L-Header Designation	20 psf Ground Snow Load					30 psf Ground Snow Load				
	Building Width					Building Width				
	24'	28'	32'	36'	40'	24'	28'	32'	36'	40'
2-600L150-43	5'-1"	4'-9"	4'-6"	4'-3"	4'-0"	4'-9"	4'-6"	4'-3"	4'-0"	3'-10"
2-600L150-54	7'-0"	7'-7"	6'-2"	5'-10"	5'-7"	6'-7"	6'-2"	5'-10"	5'-7"	5'-4"
2-600L150-68	8'-2"	7'-7"	7'-2"	6'-10"	6'-6"	7'-8"	7'-2"	6'-9"	6'-5"	6'-2"
2-800L150-43	6'-5"	6'-0"	5'-8"	5'-4"	5'-1"	6'-0"	5'-8"	5'-4"	5'-1"	4'-10"
2-800L150-54	8'-11"	8'-4"	7'-10"	7'-5"	7'-1"	8'-4"	7'-10"	7'-5"	7'-0"	6'-9"
2-800L150-68	10'-3"	9'-7"	9'-1"	8'-7"	8'-2"	9'-8"	9'-1"	8'-7"	8'-2"	7'-9"
2-1000L150-43	6'-6"	6'-1"	5'-9"	5'-5"	5'-2"	6'-2"	5'-9"	5'-5"	5'-2"	4'-11"
2-1000L150-54	9'-0"	8'-5"	7'-11"	7'-6"	7'-2"	8'-6"	7'-11"	7'-6"	7'-1"	6'-10"
2-1000L150-68	10'-4"	9'-8"	9'-2"	8'-8"	8'-3"	9'-9"	9'-2"	8'-8"	8'-2"	7'-10"

For SI: 1 inch = 25.4 mm, 1 mil = 0.0254 mm, 1 psf = 0.0479 kN/m², 1 foot = 0.305 m

¹ Building width is measured in the direction of horizontal framing members supported by the header.

² Design assumptions:

Roof and ceiling dead load = 12 psf (0.58 kN/m²)

2-foot (0.61-m) roof overhang

³ The minimum yield strength, F_y , of cold-formed steel framing members is 50 ksi (340 MPa) for members with a designation thickness equal to or greater than 54 mils.

Table E7-15
Double L-Header Spans – Gravity Loading
Headers Supporting Roof and Ceiling Only ^{1,2,3}

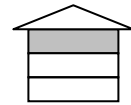

Double L-Header Designation	50 psf Ground Snow Load					70 psf Ground Snow Load				
	Building Width					Building Width				
	24'	28'	32'	36'	40'	24'	28'	32'	36'	40'
2-600L150-43	3'-11"	3'-8"	3'-6"	3'-4"	3'-2"	3'-5"	3'-2"	3'-0"	2'-10"	2'-9"
2-600L150-54	5'-5"	5'-1"	4'-10"	4'-7"	4'-4"	4'-8"	4'-5"	4'-2"	3'-11"	3'-9"
2-600L150-68	6'-3"	5'-11"	5'-7"	5'-4"	5'-1"	5'-6"	5'-2"	4'-10"	4'-7"	4'-5"
2-800L150-43	4'-11"	4'-8"	4'-5"	4'-2"	4'-0"	4'-4"	4'-1"	3'-10"	3'-8"	3'-6"
2-800L150-54	6'-10"	6'-5"	6'-1"	5'-9"	5'-6"	5'-11"	5'-7"	5'-3"	5'-0"	4'-10"
2-800L150-68	7'-11"	7'-5"	7'-0"	6'-8"	6'-5"	6'-11"	6'-6"	6'-1"	5'-10"	5'-7"
2-1000L150-43	5'-0"	4'-9"	4'-5"	4'-3"	4'-1"	4'-4"	4'-1"	3'-10"	3'-8"	3'-6"
2-1000L150-54	6'-11"	6'-6"	6'-2"	5'-10"	5'-7"	6'-0"	5'-8"	5'-4"	5'-1"	4'-10"
2-1000L150-68	8'-0"	7'-6"	7'-1"	6'-9"	6'-5"	6'-11"	6'-6"	6'-2"	5'-10"	5'-7"

For SI: 1 inch = 25.4 mm, 1 mil = 0.0254 mm, 1 psf = 0.0479 kN/m², 1 foot = 0.305 m

¹ Building width is measured in the direction of horizontal framing members supported by the header.

² Design assumptions:

Roof and ceiling dead load = 12 psf (0.58 kN/m²)

2-foot (0.61-m) roof overhang

³ The minimum yield strength, F_y , of cold-formed steel framing members is 50 ksi (340 MPa) for members with a designation thickness equal to or greater than 54 mils.

Table E7-16
Double L-Header Spans – Gravity Loading
Headers Supporting One Floor, Roof and Ceiling ^{1,2,3}

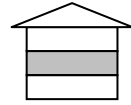

Double L-Header Designation	20 psf Ground Snow Load					30 psf Ground Snow Load				
	Building Width					Building Width				
	24'	28'	32'	36'	40'	24'	28'	32'	36'	40'
2-600L150-43	3'-9"	3'-6"	3'-4"	3'-2"	3'-0"	3'-9"	3'-6"	3'-3"	3'-1"	3'-0"
2-600L150-54	5'-2"	4'-10"	4'-7"	4'-4"	4'-2"	5'-2"	4'-10"	4'-6"	4'-4"	4'-1"
2-600L150-68	6'-0"	5'-8"	5'-4"	5'-1"	4'-10"	6'-0"	5'-7"	5'-3"	5'-0"	4'-9"
2-800L150-43	4'-9"	4'-5"	4'-2"	4'-0"	3'-10"	4'-8"	4'-5"	4'-2"	3'-11"	3'-9"
2-800L150-54	6'-7"	6'-2"	5'-10"	5'-6"	5'-3"	6'-6"	6'-1"	5'-9"	5'-5"	5'-2"
2-800L150-68	7'-7"	7'-1"	6'-9"	6'-4"	6'-1"	7'-6"	7'-1"	6'-8"	6'-3"	6'-0"
2-1000L150-43	4'-10"	4'-6"	4'-3"	4'-0"	3'-10"	4'-9"	4'-5"	4'-3"	4'-0"	3'-10"
2-1000L150-54	6'-9"	6'-3"	5'-11"	5'-7"	5'-4"	6'-7"	6'-2"	5'-10"	5'-6"	5'-3"
2-1000L150-68	7'-8"	7'-2"	6'-9"	6'-5"	6'-1"	7'-7"	7'-1"	6'-8"	6'-4"	6'-1"

For SI: 1 inch = 25.4 mm, 1 mil = 0.0254 mm, 1 psf = 0.0479 kN/m², 1 foot = 0.305 m

¹ Building width is measured in the direction of horizontal framing members supported by the header.

² Design assumptions:

Roof and ceiling dead load = 12 psf (0.58 kN/m²) Floor live load = 30 psf (1.44 kN/m²)
 2-foot (0.61-m) roof overhang Floor dead load = 10 psf (0.48 kN/m²)

³ The minimum yield strength, F_y , of cold-formed steel framing members is 50 ksi (340 MPa) for members with a designation thickness equal to or greater than 54 mils.

Table E7-17
Double L-Header Spans – Gravity Loading
Headers Supporting One Floor, Roof and Ceiling^{1,2,3}

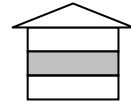

Double L-Header Designation	50 psf Ground Snow Load					70 psf Ground Snow Load				
	Building Width					Building Width				
	24'	28'	32'	36'	40'	24'	28'	32'	36'	40'
2-600L150-43	3'-4"	3'-1"	2'-11"	2'-9"	2'-7"	3'-0"	2'-9"	2'-7"	2'-6"	2'-5"
2-600L150-54	4'-7"	4'-3"	4'-0"	3'-10"	3'-7"	4'-1"	3'-10"	3'-8"	3'-6"	3'-8"
2-600L150-68	5'-4"	4'-11"	4'-8"	4'-5"	4'-3"	4'-9"	4'-6"	4'-3"	4'-1"	3'-10"
2-800L150-43	4'-2"	3'-11"	3'-8"	3'-6"	3'-4"	3'-9"	3'-6"	3'-4"	3'-2"	3'-1"
2-800L150-54	5'-9"	5'-5"	5'-1"	4'-10"	4'-7"	5'-2"	4'-11"	4'-8"	4'-5"	4'-3"
2-800L150-68	6'-8"	6'-3"	5'-11"	5'-7"	5'-4"	6'-0"	5'-8"	5'-4"	5'-1"	4'-10"
2-1000L150-43	4'-3"	4'-0"	3'-9"	3'-6"	3'-4"	3'-10"	3'-7"	3'-5"	3'-3"	3'-1"
2-1000L150-54	5'-10"	5'-6"	5'-2"	4'-11"	4'-8"	5'-3"	5'-0"	4'-8"	4'-6"	4'-3"
2-1000L150-68	6'-9"	6'-4"	5'-11"	5'-7"	5'-4"	6'-1"	5'-8"	5'-5"	5'-2"	4'-11"

For SI: 1 inch = 25.4 mm, 1 mil = 0.0254 mm, 1 psf = 0.0479 kN/m², 1 foot = 0.305 m

¹ Building width is measured in the direction of horizontal framing members supported by the header.

² Design assumptions:

Roof and ceiling dead load = 12 psf (0.58 kN/m²)

Floor live load = 30 psf (1.44 kN/m²)

2-foot (0.61-m) roof overhang

Floor dead load = 10 psf (0.48 kN/m²)

³ The minimum yield strength, F_y , of cold-formed steel framing members is 50 ksi (340 MPa) for members with a designation thickness equal to or greater than 54 mils.

Table E7-18
Double L-Header Spans – Gravity Loading
Headers Supporting Two Floors, Roof and Ceiling^{1,2,3}

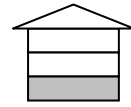

Double L-Header Designation	20 psf Ground Snow Load					30 psf Ground Snow Load				
	Building Width					Building Width				
	24'	28'	32'	36'	40'	24'	28'	32'	36'	40'
2-600L150-43	2'-9"	2'-7"	2'-5"	2'-3"	2'-2"	2'-9"	2'-7"	2'-5"	2'-3"	2'-2"
2-600L150-54	3'-9"	3'-7"	3'-4"	3'-2"	3'-0"	3'-9"	3'-6"	3'-4"	3'-2"	3'-0"
2-600L150-68	4'-5"	4'-1"	3'-11"	3'-8"	3'-6"	4'-5"	4'-1"	3'-10"	3'-8"	3'-6"
2-800L150-43	3'-6"	3'-3"	3'-1"	2'-11"	2'-9"	3'-6"	3'-3"	3'-1"	2'-11"	2'-9"
2-800L150-54	4'-10"	4'-6"	4'-3"	4'-0"	3'-10"	4'-9"	4'-6"	4'-3"	4'-0"	3'-10"
2-800L150-68	5'-7"	5'-2"	4'-11"	4'-8"	4'-5"	5'-6"	5'-2"	4'-10"	4'-7"	4'-5"
2-1000L150-43	3'-6"	3'-4"	3'-1"	2'-11"	2'-10"	3'-6"	3'-3"	3'-1"	2'-11"	2'-9"
2-1000L150-54	4'-10"	4'-7"	4'-3"	4'-1"	3'-11"	4'-10"	4'-6"	4'-3"	4'-1"	3'-10"
2-1000L150-68	5'-7"	5'-3"	4'-11"	4'-8"	4'-6"	5'-7"	5'-3"	4'-11"	4'-8"	4'-5"

For SI: 1 inch = 25.4 mm, 1 mil = 0.0254 mm, 1 psf = 0.0479 kN/m², 1 foot = 0.305 m

¹ Building width is measured in the direction of horizontal framing members supported by the header.

² Design assumptions:

Roof and ceiling dead load = 12 psf (0.58 kN/m²)

Floor live load = 30 psf (1.44 kN/m²)

2-foot (0.61-m) roof overhang

Floor dead load = 10 psf (0.48 kN/m²)

³ The minimum yield strength, F_y , of cold-formed steel framing members is 50 ksi (340 MPa) for members with a designation thickness equal to or greater than 54 mils.

Table E7-19
Double L-Header Spans – Gravity Loading
Headers Supporting Two Floors, Roof and Ceiling^{1,2,3}

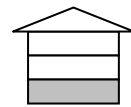

Double L-Header Designation	50 psf Ground Snow Load					70 psf Ground Snow Load				
	Building Width					Building Width				
	24'	28'	32'	36'	40'	24'	28'	32'	36'	40'
2-600L150-43	2'-8"	2'-6"	2'-4"	2'-3"	2'-1"	2'-7"	2'-5"	2'-3"	2'-2"	2'-1"
2-600L150-54	3'-8"	3'-5"	3'-3"	3'-1"	2'-11"	3'-7"	3'-4"	3'-2"	3'-0"	2'-10"
2-600L150-68	4'-3"	4'-0"	3'-9"	3'-7"	3'-5"	4'-2"	3'-11"	3'-8"	3'-6"	3'-4"
2-800L150-43	3'-4"	3'-2"	3'-0"	2'-10"	2'-8"	3'-4"	3'-1"	2'-11"	2'-9"	2'-8"
2-800L150-54	4'-8"	4'-4"	4'-1"	3'-11"	3'-8"	4'-7"	4'-3"	4'-0"	3'-10"	3'-8"
2-800L150-68	5'-5"	5'-0"	4'-9"	4'-6"	4'-3"	5'-3"	4'-11"	4'-8"	4'-5"	4'-2"
2-1000L150-43	3'-5"	3'-2"	3'-0"	2'-10"	2'-9"	3'-4"	3'-2"	2'-11"	2'-10"	2'-8"
2-1000L150-54	4'-9"	4'-5"	4'-2"	3'-11"	3'-9"	4'-7"	4'-4"	4'-1"	3'-10"	3'-8"
2-1000L150-68	5'-5"	5'-1"	4'-9"	4'-6"	4'-4"	5'-4"	5'-0"	4'-8"	4'-5"	4'-3"

For SI: 1 inch = 25.4 mm, 1 mil = 0.0254 mm, 1 psf = 0.0479 kN/m², 1 foot = 0.305 m

¹ Building width is measured in the direction of horizontal framing members supported by the header.

² Design assumptions:

Roof and ceiling dead load = 12 psf (0.58 kN/m²)

Floor live load = 30 psf (1.44 kN/m²)

2-foot (0.61-m) roof overhang

Floor dead load = 10 psf (0.48 kN/m²)

³ The minimum yield strength, F_y , of cold-formed steel framing members is 50 ksi (340 MPa) for members with a designation thickness equal to or greater than 54 mils.

Table E7-20
Double L-Header Spans - Uplift Loading
Headers Supporting Roof and Ceiling Only
24-Foot-Wide Building ^{1,2,3}

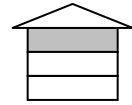

EXPOSURE B	Wind Speed, mph									
	115	120	130	140	150	160	170	180		
EXPOSURE C			115	120	130	140	150	160	170	180
Double L-Header Designation										
2-600L150-43	5'-2"	4'-9"	3'-10"	3'-7"	3'-2"	2'-10"	2'-7"	2'-5"	2'-3"	2'-1"
2-600L150-54	7'-1"	6'-6"	5'-3"	4'-11"	4'-4"	3'-11"	3'-7"	3'-4"	3'-1"	2'-11"
2-600L150-68	8'-3"	7'-7"	6'-1"	5'-9"	5'-1"	4'-7"	4'-2"	3'-10"	3'-7"	3'-4"
2-800L150-43	5'-10"	5'-4"	4'-4"	4'-0"	3'-7"	3'-3"	3'-0"	2'-9"	2'-6"	2'-5"
2-800L150-54	9'-0"	8'-3"	6'-8"	6'-3"	5'-7"	5'-0"	4'-7"	4'-3"	3'-11"	3'-8"
2-800L150-68	10'-5"	9'-7"	7'-8"	7'-2"	6'-5"	5'-9"	5'-3"	4'-11"	4'-6"	4'-3"
2-1000L150-43	6'-8"	6'-2"	4'-11"	4'-8"	4'-1"	3'-9"	3'-5"	3'-2"	2'-11"	2'-9"
2-1000L150-54	9'-3"	8'-6"	6'-10"	6'-5"	5'-8"	5'-2"	4'-8"	4'-4"	4'-0"	3'-9"
2-1000L150-68	11'-11"	10'-11"	8'-10"	8'-3"	7'-4"	6'-7"	6'-1"	5'-7"	5'-2"	4'-10"

For SI: 1 inch = 25.4 mm, 1 mil = 0.0254 mm, 1 mph = 1.61 km/hr = 0.447 m/sec, 1 foot = 0.305 m

¹ Building width is measured in the direction of horizontal framing members supported by the header.

² Design assumptions: Roof and ceiling dead load = 12 psf (0.58 kN/m²), 2-foot (0.61-m) roof overhang

³ The minimum yield strength, F_y , of cold-formed steel framing members is 50 ksi (340 MPa) for members with a designation thickness equal to or greater than 54 mils.

Table E7-21
Double L-Header Spans - Uplift Loading
Headers Supporting Roof and Ceiling Only
28-Foot-Wide Building ^{1,2,3}

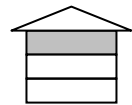

EXPOSURE B	Wind Speed, mph									
	115	120	130	140	150	160	170	180		
EXPOSURE C			115	120	130	140	150	160	170	180
Double L-Header Designation										
2-600L150-43	4'-10"	4'-6"	3'-7"	3'-4"	3'-0"	3'-8"	2'-5"	2'-3"	2'-1"	2'-0"
2-600L150-54	6'-9"	6'-2"	4'-11"	4'-8"	4'-1"	3'-9"	3'-5"	3'-2"	2'-11"	2'-9"
2-600L150-68	7'-10"	7'-2"	5'-9"	5'-5"	4'-10"	4'-4"	3'-11"	3'-8"	3'-5"	3'-2"
2-800L150-43	5'-6"	5'-1"	4'-1"	3'-10"	3'-5"	3'-1"	2'-9"	2'-7"	2'-5"	2'-3"
2-800L150-54	8'-6"	7'-10"	6'-3"	5'-11"	5'-3"	4'-9"	4'-4"	4'-0"	3'-8"	3'-5"
2-800L150-68	9'-10"	9'-1"	7'-3"	6'-10"	6'-1"	5'-5"	5'-0"	4'-7"	4'-3"	4'-0"
2-1000L150-43	6'-4"	5'-10"	4'-8"	4'-4"	3'-11"	3'-6"	3'-2"	3'-0"	2'-9"	2'-7"
2-1000L150-54	8'-9"	8'-1"	6'-5"	6'-1"	5'-4"	4'-10"	4'-5"	4'-1"	3'-10"	3'-7"
2-1000L150-68	11'-3"	10'-4"	8'-4"	7'-9"	6'-11"	6'-3"	5'-8"	5'-3"	4'-11"	4'-7"

For SI: 1 inch = 25.4 mm, 1 mil = 0.0254 mm, 1 mph = 1.61 km/hr = 0.447 m/sec, 1 foot = 0.305 m

¹ Building width is measured in the direction of horizontal framing members supported by the header.

² Design assumptions: Roof and ceiling dead load = 12 psf (0.58 kN/m²), 2-foot (0.61-m) roof overhang

³ The minimum yield strength, F_y , of cold-formed steel framing members is 50 ksi (340 MPa) for members with a designation thickness equal to or greater than 54 mils.

Table E7-22
Double L-Header Spans - Uplift Loading
Headers Supporting Roof and Ceiling Only
32-Foot-Wide Building ^{1,2,3}

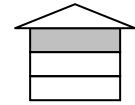

EXPOSURE B	Wind Speed, mph									
	115	120	130	140	150	160	170	180		
EXPOSURE C			115	120	130	140	150	160	170	180
Double L-Header Designation										
2-600L150-43	4'-7"	4'-3"	3'-5"	3'-2"	2'-10"	2'-7"	2'-4"	2'-2"	2'-0"	1'-10"
2-600L150-54	6'-5"	5'-10"	4'-8"	4'-5"	3'-11"	3'-6"	3'-3"	3'-0"	2'-9"	2'-7"
2-600L150-68	7'-5"	6'-10"	5'-6"	5'-2"	4'-7"	4'-1"	3'-9"	3'-5"	3'-3"	3'-0"
2-800L150-43	5'-3"	4'-10"	3'-10"	3'-7"	3'-3"	2'-11"	2'-8"	2'-5"	2'-3"	2'-1"
2-800L150-54	8'-1"	7'-5"	6'-0"	5'-7"	5'-0"	4'-6"	4'-1"	3'-9"	3'-6"	3'-3"
2-800L150-68	9'-5"	8'-7"	6'-11"	6'-5"	5'-9"	5'-2"	4'-9"	4'-4"	4'-1"	3'-9"
2-1000L150-43	6'-0"	5'-6"	4'-5"	4'-2"	3'-8"	3'-4"	3'-1"	2'-10"	2'-7"	2'-5"
2-1000L150-54	8'-4"	7'-8"	6'-1"	5'-9"	5'-1"	4'-7"	4'-2"	3'-10"	3'-7"	3'-4"
2-1000L150-68	10'-9"	9'-10"	7'-11"	7'-4"	6'-7"	5'-11"	5'-5"	5'-0"	4'-7"	4'-4"

For SI: 1 inch = 25.4 mm, 1 mil = 0.0254 mm, 1 mph = 1.61 km/hr = 0.447 m/sec, 1 foot = 0.305 m

- ¹ Building width is measured in the direction of horizontal framing members supported by the header.
- ² Design assumptions: Roof and ceiling dead load = 12 psf (0.58 kN/m²), 2-foot (0.61-m) roof overhang
- ³ The minimum yield strength, F_y , of cold-formed steel framing members is 50 ksi (340 MPa) for members with a designation thickness equal to or greater than 54 mils.

Table E7-23
Double L-Header Spans - Uplift Loading
Headers Supporting Roof and Ceiling Only
36-Foot-Wide Building ^{1,2,3}

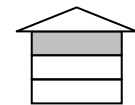

EXPOSURE B	Wind Speed, mph									
	115	120	130	140	150	160	170	180		
EXPOSURE C			115	120	130	140	150	160	170	180
Double L-Header Designation										
2-600L150-43	4'-5"	4'-1"	3'-3"	3'-0"	2'-8"	2'-5"	2'-3"	2'-1"	1'-11"	1'-9"
2-600L150-54	6'-1"	5'-7"	4'-6"	4'-2"	3'-9"	3'-4"	3'-1"	2'-10"	2'-8"	2'-5"
2-600L150-68	7'-1"	6'-6"	5'-3"	4'-11"	4'-4"	3'-11"	3'-7"	3'-4"	3'-1"	2'-10"
2-800L150-43	5'-0"	4'-7"	3'-8"	3'-5"	3'-1"	2'-9"	2'-6"	2'-4"	2'-2"	2'-0"
2-800L150-54	7'-9"	7'-1"	5'-8"	5'-4"	4'-9"	4'-3"	3'-11"	3'-7"	3'-4"	3'-1"
2-800L150-68	9'-0"	8'-3"	6'-7"	6'-2"	5'-6"	4'-11"	4'-6"	4'-2"	3'-10"	3'-7"
2-1000L150-43	5'-9"	5'-3"	4'-3"	3'-11"	3'-6"	3'-2"	2'-11"	2'-8"	2'-6"	2'-4"
2-1000L150-54	8'-0"	7'-4"	5'-10"	5'-6"	4'-11"	4'-5"	4'-0"	3'-8"	3'-5"	3'-2"
2-1000L150-68	10'-3"	9'-5"	7'-6"	7'-0"	6'-3"	5'-8"	5'-2"	4'-9"	4'-5"	4'-1"

For SI: 1 inch = 25.4 mm, 1 mil = 0.0254 mm, 1 mph = 1.61 km/hr = 0.447 m/sec, 1 foot = 0.305 m

- ¹ Building width is measured in the direction of horizontal framing members supported by the header.
- ² Design assumptions: Roof and ceiling dead load = 12 psf (0.58 kN/m²), 2-foot (0.61-m) roof overhang
- ³ The minimum yield strength, F_y , of cold-formed steel framing members is 50 ksi (340 MPa) for members with a designation thickness equal to or greater than 54 mils.

Table E7-24
Double L-Header Spans - Uplift Loading
Headers Supporting Roof and Ceiling Only
40-Foot-Wide Building^{1,2,3}

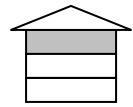

EXPOSURE B	Wind Speed, mph									
	115	120	130	140	150	160	170	180		
EXPOSURE C			115	120	130	140	150	160	170	180
Double L-Header Designation										
2-600L150-43	4'-3"	3'-11"	3'-1"	2'-11"	2'-7"	2'-4"	2'-2"	2'-0"	1'-10"	1'-8"
2-600L150-54	5'-10"	5'-4"	4'-4"	4'-0"	3'-7"	3'-3"	2'-11"	2'-9"	2'-6"	2'-4"
2-600L150-68	6'-10"	6'-3"	5'-0"	4'-8"	4'-2"	3'-9"	3'-5"	3'-2"	2'-11"	2'-9"
2-800L150-43	4'-10"	4'-5"	3'-6"	3'-4"	2'-11"	2'-8"	2'-5"	2'-3"	2'-1"	1'-11"
2-800L150-54	7'-5"	6'-10"	5'-5"	5'-1"	4'-6"	4'-1"	3'-9"	3'-5"	3'-2"	3'-0"
2-800L150-68	8'-7"	7'-11"	6'-4"	5'-11"	5'-3"	4'-9"	4'-4"	4'-0"	3'-8"	3'-5"
2-1000L150-43	5'-6"	5'-1"	4'-1"	3'-9"	3'-4"	3'-0"	2'-9"	2'-7"	2'-4"	2'-3"
2-1000L150-54	7'-8"	7'-0"	5'-7"	5'-3"	4'-8"	4'-2"	3'-10"	3'-6"	3'-3"	3'-1"
2-1000L150-68	9'-10"	9'-0"	7'-2"	6'-9"	6'-0"	5'-5"	4'-11"	4'-7"	4'-3"	3'-11"

For SI: 1 inch = 25.4 mm, 1 mil = 0.0254 mm, 1 mph = 1.61 km/hr = 0.447 m/sec, 1 foot = 0.305 m

- Building width is measured in the direction of horizontal framing members supported by the header.
- Design assumptions: Roof and ceiling dead load = 12 psf (0.58 kN/m²), 2-foot (0.61-m) roof overhang
- The minimum yield strength, F_y , of cold-formed steel framing members is 50 ksi (340 MPa) for members with a designation thickness equal to or greater than 54 mils.

Table E7-25
Double L-Header Spans - Uplift Loading
Headers Supporting One Floor, Roof and Ceiling
24-Foot-Wide Building^{1,2,3,4}

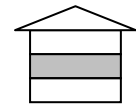

EXPOSURE B	Wind Speed, mph									
	115	120	130	140	150	160	170	180		
EXPOSURE C			115	120	130	140	150	160	170	180
Double L-Header Designation										
2-600L150-43	N/U	N/U	6'-11"	5'-9"	4'-5"	3'-8"	3'-2"	2'-11"	2'-7"	2'-4"
2-600L150-54	N/U	N/U	9'-7"	7'-11"	6'-1"	5'-1"	4'-5"	3'-11"	3'-7"	3'-3"
2-600L150-68	N/U	N/U	11'-2"	9'-1"	7'-1"	5'-11"	5'-2"	4'-7"	4'-2"	3'-9"
2-800L150-43	N/U	N/U	7'-10"	6'-6"	5'-0"	4'-2"	3'-7"	3'-3"	2'-11"	2'-8"
2-800L150-54	N/U	N/U	12'-2"	10'-0"	7'-9"	6'-5"	5'-7"	5'-0"	4'-6"	4'-2"
2-800L150-68	N/U	N/U	14'-2"	11'-7"	8'-11"	7'-5"	6'-6"	5'-9"	5'-2"	4'-9"
2-1000L150-43	N/U	N/U	9'-1"	7'-5"	5'-9"	4'-10"	4'-2"	3'-8"	3'-4"	3'-1"
2-1000L150-54	N/U	N/U	12'-6"	10'-4"	7'-11"	6'-8"	5'-9"	5'-1"	4'-8"	4'-3"
2-1000L150-68	N/U	N/U	16'-0"	13'-3"	10'-3"	8'-6"	7'-5"	6'-7"	5'-11"	5'-5"

For SI: 1 inch = 25.4 mm, 1 mil = 0.0254 mm, 1 mph = 1.61 km/hr = 0.447 m/sec, 1 foot = 0.305 m

- Building width is measured in the direction of horizontal framing members supported by the header.
- Design assumptions: Roof and ceiling dead load = 12 psf (0.58 kN/m²) Floor live load = 30 psf (1.44 kN/m²)
Floor dead load = 10 psf (0.48 kN/m²) 2-foot (0.61-m) roof overhang
- N/U indicates no net uplift loads acting on header. Header need only be selected based on gravity loading.
- The minimum yield strength, F_y , of cold-formed steel framing members is 50 ksi (340 MPa) for members with a designation thickness equal to or greater than 54 mils.

Table E7-26
Double L-Header Spans - Uplift Loading
Headers Supporting One Floor, Roof and Ceiling
28-Foot-Wide Building^{1,2,3,4}

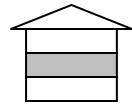

EXPOSURE B	Wind Speed, mph									
	115	120	130	140	150	160	170	180		
EXPOSURE C			115	120	130	140	150	160	170	180
Double L-Header Designation										
2-600L150-43	N/U	N/U	6'-5"	5'-4"	4'-1"	3'-5"	3'-0"	2'-8"	2'-5"	2'-2"
2-600L150-54	N/U	N/U	8'-10"	7'-4"	5'-8"	4'-9"	4'-2"	3'-8"	3'-4"	3'-1"
2-600L150-68	N/U	N/U	10'-4"	8'-6"	6'-7"	5'-6"	4'-10"	4'-3"	3'-11"	3'-7"
2-800L150-43	N/U	N/U	7'-3"	6'-0"	4'-8"	3'-11"	3'-4"	3'-0"	2'-9"	2'-6"
2-800L150-54	N/U	N/U	11'-3"	9'-3"	7'-3"	6'-0"	5'-3"	4'-8"	4'-3"	3'-10"
2-800L150-68	N/U	N/U	13'-0"	10'-9"	8'-4"	7'-0"	6'-1"	5'-5"	4'-11"	4'-6"
2-1000L150-43	N/U	N/U	8'-4"	6'-11"	5'-4"	4'-6"	3'-11"	3'-6"	3'-2"	2'-11"
2-1000L150-54	N/U	N/U	11'-6"	9'-7"	7'-5"	6'-2"	5'-5"	4'-10"	4'-4"	4'-0"
2-1000L150-68	N/U	N/U	14'-10"	12'-4"	9'-6"	8'-0"	6'-11"	6'-2"	5'-7"	5'-1"

For SI: 1 inch = 25.4 mm, 1 mil = 0.0254 mm, 1 mph = 1.61 km/hr = 0.447 m/sec, 1 foot = 0.305 m

- Building width is measured in the direction of horizontal framing members supported by the header.
- Design assumptions: Roof and ceiling dead load = 12 psf (0.58 kN/m²) Floor live load = 30 psf (1.44 kN/m²)
Floor dead load = 10 psf (0.48 kN/m²) 2-foot (0.61-m) roof overhang
- N/U indicates no net uplift loads acting on header. Header need only be selected based on gravity loading.
- The minimum yield strength, F_y , of cold-formed steel framing members is 50 ksi (340 MPa) for members with a designation thickness equal to or greater than 54 mils.

Table E7-27
Double L-Header Spans - Uplift Loading
Headers Supporting One Floor, Roof and Ceiling
32-Foot-Wide Building^{1,2,3,4}

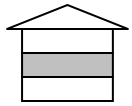

EXPOSURE B	Wind Speed, mph									
	115	120	130	140	150	160	170	180		
EXPOSURE C			115	120	130	140	150	160	170	180
Double L-Header Designation										
2-600L150-43	N/U	N/U	6'-0"	5'-0"	3'-10"	3'-3"	2'-10"	2'-6"	2'-3"	2'-1"
2-600L150-54	N/U	N/U	8'-3"	6'-11"	5'-4"	4'-6"	3'-11"	3'-6"	3'-2"	2'-11"
2-600L150-68	N/U	N/U	9'-7"	8'-0"	6'-3"	5'-3"	4'-6"	4'-1"	3'-8"	3'-4"
2-800L150-43	N/U	N/U	6'-9"	5'-8"	4'-5"	3'-8"	3'-2"	2'-10"	2'-7"	2'-5"
2-800L150-54	N/U	N/U	10'-6"	8'-9"	6'-9"	5'-8"	4'-11"	4'-5"	4'-0"	3'-8"
2-800L150-68	N/U	N/U	12'-1"	10'-1"	7'-10"	6'-7"	5'-9"	5'-1"	4'-7"	4'-3"
2-1000L150-43	N/U	N/U	7'-9"	6'-6"	5'-1"	4'-3"	3'-8"	3'-3"	3'-0"	2'-9"
2-1000L150-54	N/U	N/U	10'-9"	9'-0"	7'-0"	5'-10"	5'-1"	4'-6"	4'-1"	3'-9"
2-1000L150-68	N/U	N/U	13'-10"	11'-6"	9'-0"	7'-6"	6'-6"	5'-10"	5'-3"	4'-10"

For SI: 1 inch = 25.4 mm, 1 mil = 0.0254 mm, 1 mph = 1.61 km/hr = 0.447 m/sec, 1 foot = 0.305 m

- Building width is measured in the direction of horizontal framing members supported by the header.
- Design assumptions: Roof and ceiling dead load = 12 psf (0.58 kN/m²) Floor live load = 30 psf (1.44 kN/m²)
Floor dead load = 10 psf (0.48 kN/m²) 2-foot (0.61-m) roof overhang
- N/U indicates no net uplift loads acting on header. Header need only be selected based on gravity loading.
- The minimum yield strength, F_y , of cold-formed steel framing members is 50 ksi (340 MPa) for members with a designation thickness equal to or greater than 54 mils.

Table E7-28
Double L-Header Spans - Uplift Loading
Headers Supporting One Floor, Roof and Ceiling
36-Foot-Wide Building ^{1,2,3,4}

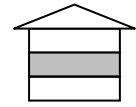

EXPOSURE B	Wind Speed, mph									
	115	120	130	140	150	160	170	180		
EXPOSURE C			115	120	130	140	150	160	170	180
Double L-Header Designation										
2-600L150-43	N/U	N/U	5'-7"	4'-8"	3'-8"	3'-1"	2'-8"	2'-5"	2'-2"	2'-0"
2-600L150-54	N/U	N/U	7'-9"	6'-6"	5'-1"	4'-3"	3'-7"	3'-4"	3'-0"	2'-9"
2-600L150-68	N/U	N/U	9'-0"	7'-7"	5'-11"	5'-0"	4'-4"	3'-10"	3'-6"	3'-2"
2-800L150-43	N/U	N/U	6'-4"	5'-4"	4'-2"	3'-6"	3'-1"	2'-9"	2'-5"	2'-3"
2-800L150-54	N/U	N/U	9'-10"	8'-3"	6'-5"	5'-5"	4'-8"	4'-2"	3'-10"	3'-6"
2-800L150-68	N/U	N/U	11'-5"	9'-6"	7'-5"	6'-3"	5'-5"	4'-11"	4'-5"	4'-0"
2-1000L150-43	N/U	N/U	7'-4"	6'-1"	4'-9"	4'-0"	3'-6"	3'-1"	2'-10"	2'-7"
2-1000L150-54	N/U	N/U	10'-1"	8'-6"	6'-7"	5'-7"	4'-10"	4'-4"	3'-11"	3'-7"
2-1000L150-68	N/U	N/U	13'-0"	10'-11"	8'-6"	7'-2"	6'-3"	5'-6"	5'-0"	4'-7"

For SI: 1 inch = 25.4 mm, 1 mil = 0.0254 mm, 1 mph = 1.61 km/hr = 0.447 m/sec, 1 foot = 0.305 m

- Building width is measured in the direction of horizontal framing members supported by the header.
- Design assumptions: Roof and ceiling dead load = 12 psf (0.58 kN/m²) Floor live load = 30 psf (1.44 kN/m²)
Floor dead load = 10 psf (0.48 kN/m²) 2-foot (0.61-m) roof overhang
- N/U indicates no net uplift loads acting on header. Header need only be selected based on gravity loading.
- The minimum yield strength, F_y , of cold-formed steel framing members is 50 ksi (340 MPa) for members with a designation thickness equal to or greater than 54 mils.

Table E7-29
Double L-Header Spans - Uplift Loading
Headers Supporting One Floor, Roof and Ceiling
40-Foot-Wide Building ^{1,2,3,4}

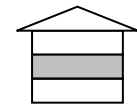

EXPOSURE B	Wind Speed, mph									
	115	120	130	140	150	160	170	180		
EXPOSURE C			115	120	130	140	150	160	170	180
Double L-Header Designation										
2-600L150-43	N/U	N/U	5'-4"	4'-6"	3'-6"	2'-11"	2'-7"	2'-3"	2'-1"	1'-11"
2-600L150-54	N/U	N/U	7'-4"	6'-2"	4'-10"	4'-1"	3'-6"	3'-2"	2'-10"	2'-7"
2-600L150-68	N/U	N/U	8'-7"	7'-2"	5'-7"	4'-9"	4'-1"	3'-8"	3'-4"	3'-1"
2-800L150-43	N/U	N/U	6'-0"	5'-1"	4'-0"	3'-4"	2'-11"	2'-7"	2'-4"	2'-2"
2-800L150-54	N/U	N/U	9'-4"	7'-10"	6'-1"	5'-2"	4'-6"	4'-0"	3'-7"	3'-4"
2-800L150-68	N/U	N/U	10'-9"	9'-1"	7'-1"	5'-11"	5'-2"	4'-7"	4'-2"	3'-10"
2-1000L150-43	N/U	N/U	6'-11"	5'-10"	4'-7"	3'-10"	3'-4"	3'-0"	2'-8"	2'-6"
2-1000L150-54	N/U	N/U	9'-7"	8'-1"	6'-4"	5'-3"	4'-7"	4'-1"	3'-9"	3'-5"
2-1000L150-68	N/U	N/U	12'-4"	10'-4"	8'-1"	6'-10"	5'-11"	5'-3"	4'-9"	4'-5"

For SI: 1 inch = 25.4 mm, 1 mil = 0.0254 mm, 1 mph = 1.61 km/hr = 0.447 m/sec, 1 foot = 0.305 m

- Building width is measured in the direction of horizontal framing members supported by the header.
- Design assumptions: Roof and ceiling dead load = 12 psf (0.58 kN/m²) Floor live load = 30 psf (1.44 kN/m²)
Floor dead load = 10 psf (0.48 kN/m²) 2-foot (0.61-m) roof overhang
- N/U indicates no net uplift loads acting on header. Header need only be selected based on gravity loading.
- The minimum yield strength, F_y , of cold-formed steel framing members is 50 ksi (340 MPa) for members with a designation thickness equal to or greater than 54 mils.

Table E7-30
Double L-Header Spans - Uplift Loading
Headers Supporting Two Floors, Roof and Ceiling
24-Foot-Wide Building^{1,2,3,4}

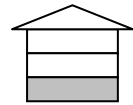

EXPOSURE B	Wind Speed, mph									
	115	120	130	140	150	160	170	180		
EXPOSURE C			115	120	130	140	150	160	170	180
Double L-Header Designation										
2-600L150-43	N/U	N/U	N/U	N/U	16'-0"	6'-3"	4'-6"	3'-8"	3'-1"	2'-9"
2-600L150-54	N/U	N/U	N/U	N/U	16'-0"	8'-8"	6'-1"	5'-0"	4'-4"	3'-10"
2-600L150-68	N/U	N/U	N/U	N/U	16'-0"	10'-1"	7'-3"	5'-10"	5'-0"	4'-5"
2-800L150-43	N/U	N/U	N/U	N/U	16'-0"	7'-2"	5'-1"	4'-2"	3'-6"	3'-1"
2-800L150-54	N/U	N/U	N/U	N/U	16'-0"	11'-0"	7'-11"	6'-5"	5'-6"	4'-10"
2-800L150-68	N/U	N/U	N/U	N/U	16'-0"	12'-9"	9'-1"	7'-5"	6'-4"	5'-7"
2-1000L150-43	N/U	N/U	N/U	N/U	16'-0"	8'-2"	5'-10"	4'-9"	4'-1"	3'-7"
2-1000L150-54	N/U	N/U	N/U	N/U	16'-0"	11'-4"	8'-1"	6'-7"	5'-7"	5'-0"
2-1000L150-68	N/U	N/U	N/U	N/U	16'-0"	14'-7"	10'-5"	8'-5"	7'-3"	6'-5"

For SI: 1 inch = 25.4 mm, 1 mil = 0.0254 mm, 1 mph = 1.61 km/hr = 0.447 m/sec, 1 foot = 0.305 m

- Building width is measured in the direction of horizontal framing members supported by the header.
- Design assumptions: Roof and ceiling dead load = 12 psf (0.58 kN/m²) Floor live load = 30 psf (1.44 kN/m²)
Floor dead load = 10 psf (0.48 kN/m²) 2-foot (0.61-m) roof overhang
- N/U indicates no net uplift loads acting on header. Header need only be selected based on gravity loading.
- The minimum yield strength, F_y , of cold-formed steel framing members is 50 ksi (340 MPa) for members with a designation thickness equal to or greater than 54 mils.

Table E7-31
Double L-Header Spans - Uplift Loading
Headers Supporting Two Floors, Roof and Ceiling
28-Foot-Wide Building^{1,2,3,4}

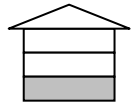

EXPOSURE B	Wind Speed, mph									
	115	120	130	140	150	160	170	180		
EXPOSURE C			115	120	130	140	150	160	170	180
Double L-Header Designation										
2-600L150-43	N/U	N/U	N/U	N/U	13'-6"	5'-8"	4'-2"	3'-5"	2'-11"	2'-7"
2-600L150-54	N/U	N/U	N/U	N/U	16'-0"	7'-10"	5'-9"	4'-8"	4'-0"	3'-7"
2-600L150-68	N/U	N/U	N/U	N/U	16'-0"	9'-2"	6'-8"	5'-5"	4'-8"	4'-2"
2-800L150-43	N/U	N/U	N/U	N/U	15'-3"	6'-5"	4'-8"	3'-10"	3'-4"	2'-11"
2-800L150-54	N/U	N/U	N/U	N/U	16'-0"	10'-0"	7'-3"	5'-11"	5'-1"	4'-6"
2-800L150-68	N/U	N/U	N/U	N/U	16'-0"	11'-6"	8'-5"	6'-10"	5'-11"	5'-2"
2-1000L150-43	N/U	N/U	N/U	N/U	16'-0"	7'-5"	5'-5"	4'-5"	3'-9"	3'-4"
2-1000L150-54	N/U	N/U	N/U	N/U	16'-0"	10'-3"	7'-6"	6'-1"	5'-3"	4'-8"
2-1000L150-68	N/U	N/U	N/U	N/U	16'-0"	13'-2"	10'-7"	7'-10"	6'-9"	5'-11"

For SI: 1 inch = 25.4 mm, 1 mil = 0.0254 mm, 1 mph = 1.61 km/hr = 0.447 m/sec, 1 foot = 0.305 m

- Building width is measured in the direction of horizontal framing members supported by the header.
- Design assumptions: Roof and ceiling dead load = 12 psf (0.58 kN/m²) Floor live load = 30 psf (1.44 kN/m²)
Floor dead load = 10 psf (0.48 kN/m²) 2-foot (0.61-m) roof overhang
- N/U indicates no net uplift loads acting on header. Header need only be selected based on gravity loading.
- The minimum yield strength, F_y , of cold-formed steel framing members is 50 ksi (340 MPa) for members with a designation thickness equal to or greater than 54 mils.

Table E7-32
Double L-Header Spans - Uplift Loading
Headers Supporting Two Floors, Roof and Ceiling
32-Foot-Wide Building^{1,2,3,4}

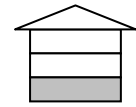

EXPOSURE B	Wind Speed, mph									
	115	120	130	140	150	160	170	180		
EXPOSURE C			115	120	130	140	150	160	170	180
Double L-Header Designation										
2-600L150-43	N/U	N/U	N/U	N/U	11'-0"	5'-3"	3'-10"	3'-2"	2'-9"	2'-5"
2-600L150-54	N/U	N/U	N/U	N/U	15'-2"	7'-3"	5'-4"	4'-5"	3'-9"	3'-4"
2-600L150-68	N/U	N/U	N/U	N/U	16'-0"	8'-5"	6'-3"	5'-1"	4'-5"	3'-11"
2-800L150-43	N/U	N/U	N/U	N/U	12'-6"	15'-11"	4'-5"	3'-7"	3'-1"	2'-9"
2-800L150-54	N/U	N/U	N/U	N/U	16'-0"	9'-2"	6'-9"	5'-7"	4'-9"	4'-3"
2-800L150-68	N/U	N/U	N/U	N/U	16'-0"	10'-7"	7'-10"	6'-5"	5'-6"	4'-11"
2-1000L150-43	N/U	N/U	N/U	N/U	14'-4"	6'-10"	5'-0"	4'-2"	3'-7"	3'-2"
2-1000L150-54	N/U	N/U	N/U	N/U	16'-0"	9'-5"	7'-0"	5'-8"	4'-11"	4'-4"
2-1000L150-68	N/U	N/U	N/U	N/U	16'-0"	12'-1"	9'-0"	7'-4"	6'-4"	5'-7"

For SI: 1 inch = 25.4 mm, 1 mil = 0.0254 mm, 1 mph = 1.61 km/hr = 0.447 m/sec, 1 foot = 0.305 m

- Building width is measured in the direction of horizontal framing members supported by the header.
- Design assumptions: Roof and ceiling dead load = 12 psf (0.58 kN/m²) Floor live load = 30 psf (1.44 kN/m²)
Floor dead load = 10 psf (0.48 kN/m²) 2-foot (0.61-m) roof overhang
- N/U indicates no net uplift loads acting on header. Header need only be selected based on gravity loading.
- The minimum yield strength, F_y , of cold-formed steel framing members is 50 ksi (340 MPa) for members with a designation thickness equal to or greater than 54 mils.

Table E7-33
Double L-Header Spans - Uplift Loading
Headers Supporting Two Floors, Roof and Ceiling
36-Foot-Wide Building^{1,2,3,4}

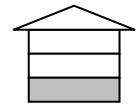

EXPOSURE B	Wind Speed, mph									
	115	120	130	140	150	160	170	180		
EXPOSURE C			115	120	130	140	150	160	170	180
Double L-Header Designation										
2-600L150-43	N/U	N/U	N/U	N/U	9'-6"	4'-10"	3'-8"	3'-0"	2'-7"	2'-3"
2-600L150-54	N/U	N/U	N/U	N/U	13'-2"	6'-9"	5'-0"	4'-2"	3'-7"	3'-2"
2-600L150-68	N/U	N/U	N/U	N/U	15'-4"	7'-10"	5'-10"	4'-10"	4'-2"	3'-8"
2-800L150-43	N/U	N/U	N/U	N/U	10'-9"	5'-6"	4'-1"	3'-5"	2'-11"	2'-7"
2-800L150-54	N/U	N/U	N/U	N/U	16'-0"	8'-6"	6'-4"	5'-3"	4'-6"	4'-0"
2-800L150-68	N/U	N/U	N/U	N/U	16'-0"	9'-10"	7'-4"	6'-1"	5'-3"	4'-8"
2-1000L150-43	N/U	N/U	N/U	N/U	12'-5"	6'-4"	4'-9"	3'-11"	3'-4"	3'-0"
2-1000L150-54	N/U	N/U	N/U	N/U	16'-0"	8'-9"	6'-6"	5'-5"	4'-8"	4'-2"
2-1000L150-68	N/U	N/U	N/U	N/U	16'-0"	11'-3"	8'-5"	6'-11"	6'-0"	5'-4"

For SI: 1 inch = 25.4 mm, 1 mil = 0.0254 mm, 1 mph = 1.61 km/hr = 0.447 m/sec, 1 foot = 0.305 m

- Building width is measured in the direction of horizontal framing members supported by the header.
- Design assumptions: Roof and ceiling dead load = 12 psf (0.58 kN/m²) Floor live load = 30 psf (1.44 kN/m²)
Floor dead load = 10 psf (0.48 kN/m²) 2-foot (0.61-m) roof overhang
- N/U indicates no net uplift loads acting on header. Header need only be selected based on gravity loading.
- The minimum yield strength, F_y , of cold-formed steel framing members is 50 ksi (340 MPa) for members with a designation thickness equal to or greater than 54 mils.

Table E7-34
Double L-Header Spans - Uplift Loading
Headers Supporting Two Floors, Roof and Ceiling
40-Foot-Wide Building^{1,2,3,4}

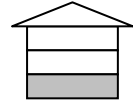

EXPOSURE B	Wind Speed, mph									
	115	120	130	140	150	160	170	180		
EXPOSURE C			115	120	130	140	150	160	170	180
Double L-Header Designation										
2-600L150-43	N/U	N/U	N/U	N/U	8'-6"	4'-7"	3'-5"	2'-10"	2'-5"	2'-2"
2-600L150-54	N/U	N/U	N/U	N/U	11'-9"	6'-4"	4'-9"	3'-11"	3'-5"	3'-0"
2-600L150-68	N/U	N/U	N/U	N/U	13'-8"	7'-4"	5'-6"	4'-7"	3'-11"	3'-6"
2-800L150-43	N/U	N/U	N/U	N/U	9'-8"	5'-2"	3'-11"	3'-3"	2'-9"	2'-6"
2-800L150-54	N/U	N/U	N/U	N/U	14'-11"	8'-0"	6'-0"	4'-0"	4'-4"	3'-10"
2-800L150-68	N/U	N/U	N/U	N/U	16'-0"	9'-3"	6'-11"	5'-9"	5'-0"	4'-5"
2-1000L150-43	N/U	N/U	N/U	N/U	11'-1"	5'-11"	4'-6"	3'-8"	3'-2"	2'-10"
2-1000L150-54	N/U	N/U	N/U	N/U	15'-4"	8'-3"	6'-2"	5'-1"	4'-5"	3'-11"
2-1000L150-68	N/U	N/U	N/U	N/U	16'-0"	10'-7"	7'-11"	6'-7"	5'-8"	5'-1"

For SI: 1 inch = 25.4 mm, 1 mil = 0.0254 mm, 1 mph = 1.61 km/hr = 0.447 m/sec, 1 foot = 0.305 m

¹ Building width is measured in the direction of horizontal framing members supported by the *header*.

² Design assumptions: Roof and ceiling dead load = 12 psf (0.58 kN/m²) Floor live load = 30 psf (1.44 kN/m²)
Floor dead load = 10 psf (0.48 kN/m²) 2-foot (0.61-m) roof overhang

³ N/U indicates no net uplift loads acting on *header*. *Header* need only be selected based on gravity loading.

⁴ The minimum *yield strength*, F_y , of *cold-formed steel* framing members is 50 ksi (340 MPa) for members with a *designation thickness* equal to or greater than 54 mils.

Table E7-35
Single L-Header Spans – Gravity Loading
Headers Supporting Roof and Ceiling Only ^{1,2,3}

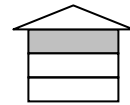

Single L-Header Designation	20 psf Ground Snow Load					30 psf Ground Snow Load				
	Building Width					Building Width				
	24'	28'	32'	36'	40'	24'	28'	32'	36'	40'
600L150-43	3'-7"	3'-4"	3'-2"	3'-0"	2'-10"	3'-4"	3'-2"	3'-0"	2'-10"	2'-8"
600L150-54	4'-0"	4'-0"	4'-0"	4'-0"	3'-11"	4'-0"	4'-0"	4'-0"	3'-11"	3'-9"
600L150-68	4'-0"	4'-0"	4'-0"	4'-0"	4'-0"	4'-0"	4'-0"	4'-0"	4'-0"	4'-0"
800L150-43	4'-0"	4'-0"	3'-10"	3'-7"	3'-5"	4'-0"	3'-10"	3'-7"	3'-5"	3'-3"
800L150-54	4'-0"	4'-0"	4'-0"	4'-0"	4'-0"	4'-0"	4'-0"	4'-0"	4'-0"	4'-0"
800L150-68	4'-0"	4'-0"	4'-0"	4'-0"	4'-0"	4'-0"	4'-0"	4'-0"	4'-0"	4'-0"

For SI: 1 inch = 25.4 mm, 1 psf = 0.0479 kN/m², 1 foot = 0.305 m

¹ Building width is measured in the direction of horizontal framing members supported by the header.

² Design assumptions:

Roof and ceiling dead load = 12 psf (0.58 kN/m²)

2-foot (0.61-m) roof overhang

³ The minimum yield strength, F_y , of cold-formed steel framing members is 50 ksi (340 MPa) for members with a designation thickness equal to or greater than 54 mils.

Table E7-36
Single L-Header Spans – Gravity Loading
Headers Supporting Roof and Ceiling Only ^{1,2,3}

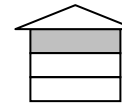

Single L-Header Designation	50 psf Ground Snow Load					70 psf Ground Snow Load				
	Building Width					Building Width				
	24'	28'	32'	36'	40'	24'	28'	32'	36'	40'
600L150-43	2'-9"	2'-7"	2'-5"	2'-4"	2'-3"	2'-5"	2'-3"	2'-2"	2'-0"	1'-11"
600L150-54	3'-10"	3'-7"	3'-5"	3'-3"	3'-1"	3'-3"	3'-1"	2'-11"	2'-10"	2'-8"
600L150-68	4'-0"	4'-0"	3'-11"	3'-9"	3'-7"	3'-10"	3'-8"	3'-5"	3'-3"	3'-1"
800L150-43	3'-4"	3'-1"	2'-11"	2'-10"	2'-8"	2'-11"	2'-9"	2'-7"	2'-5"	2'-4"
800L150-54	4'-0"	4'-0"	4'-0"	3'-11"	3'-8"	4'-0"	3'-9"	3'-7"	3'-4"	3'-3"
800L150-68	4'-0"	4'-0"	4'-0"	4'-0"	4'-0"	4'-0"	4'-0"	4'-0"	3'-11"	3'-9"

For SI: 1 inch = 25.4 mm, 1 mil = 0.0254 mm, 1 psf = 0.0479 kN/m², 1 foot = 0.305 m

¹ Building width is measured in the direction of horizontal framing members supported by the header.

² Design assumptions:

Roof and ceiling dead load = 12 psf (0.58 kN/m²)

2-foot (0.61-m) roof overhang

³ The minimum yield strength, F_y , of cold-formed steel framing members is 50 ksi (340 MPa) for members with a designation thickness equal to or greater than 54 mils.

Table E7-37
Single L-Header Spans – Gravity Loading
Headers Supporting One Floor, Roof and Ceiling^{1,2,3}

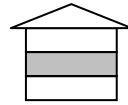

Single L-Header Designation	20 psf Ground Snow Load					30 psf Ground Snow Load				
	Building Width					Building Width				
	24'	28'	32'	36'	40'	24'	28'	32'	36'	40'
600L150-43	2'-8"	2'-6"	2'-4"	2'-3"	2'-1"	2'-7"	2'-5"	2'-4"	2'-2"	2'-1"
600L150-54	3'-8"	3'-5"	3'-3"	3'-1"	2'-11"	3'-7"	3'-5"	3'-2"	3'-0"	2'-11"
600L150-68	4'-0"	4'-0"	3'-9"	3'-7"	3'-5"	4'-0"	3'-11"	3'-9"	3'-6"	3'-4"
800L150-43	3'-2"	3'-0"	2'-10"	2'-8"	2'-7"	3'-2"	2'-11"	2'-9"	2'-8"	2'-6"
800L150-54	4'-0"	4'-0"	3'-11"	3'-8"	3'-6"	4'-0"	4'-0"	3'-10"	3'-8"	3'-6"
800L150-68	4'-0"	4'-0"	4'-0"	4'-0"	4'-0"	4'-0"	4'-0"	4'-0"	4'-0"	4'-0"

For SI: 1 inch = 25.4 mm, 1 mil = 0.0254 mm, 1 psf = 0.0479 kN/m², 1 foot = 0.305 m

¹ Building width is measured in the direction of horizontal framing members supported by the header.

² Design assumptions:

Roof and ceiling dead load = 12 psf (0.58 kN/m²), Floor live load = 30 psf (1.44 kN/m²)

2-foot (0.61-m) roof overhang, Floor dead load = 10 psf (0.48 kN/m²)

³ The minimum yield strength, F_y , of cold-formed steel framing members is 50 ksi (340 MPa) for members with a designation thickness equal to or greater than 54 mils.

Table E7-38
Single L-Header Spans – Gravity Loading
Headers Supporting One Floor, Roof and Ceiling^{1,2,3}

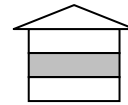

Single L-Header Designation	50 psf Ground Snow Load					70 psf Ground Snow Load				
	Building Width					Building Width				
	24'	28'	32'	36'	40'	24'	28'	32'	36'	40'
600L150-43	2'-4"	2'-2"	2'-1"	1'-11"	1'-10"	2'-1"	2'-0"	1'-10"	1'-9"	1'-8"
600L150-54	3'-3"	3'-0"	2'-10"	2'-8"	2'-7"	2'-11"	2'-9"	2'-7"	2'-5"	2'-4"
600L150-68	3'-9"	3'-6"	3'-4"	3'-2"	3'-0"	3'-5"	3'-2"	3'-0"	2'-10"	2'-9"
800L150-43	2'-10"	2'-7"	2'-6"	2'-4"	2'-3"	2'-6"	2'-5"	2'-3"	2'-2"	2'-1"
800L150-54	3'-11"	3'-7"	3'-5"	3'-3"	3'-1"	3'-6"	3'-3"	3'-1"	2'-11"	2'-10"
800L150-68	4'-0"	4'-0"	3'-11"	3'-9"	3'-7"	4'-0"	3'-10"	3'-7"	3'-5"	3'-3"

For SI: 1 inch = 25.4 mm, 1 mil = 0.0254 mm, 1 psf = 0.0479 kN/m², 1 foot = 0.305 m

¹ Building width is measured in the direction of horizontal framing members supported by the header.

² Design assumptions:

Roof and ceiling dead load = 12 psf (0.58 kN/m²), Floor live load = 30 psf (1.44 kN/m²)

2-foot (0.61-m) roof overhang, Floor dead load = 10 psf (0.48 kN/m²)

³ The minimum yield strength, F_y , of cold-formed steel framing members is 50 ksi (340 MPa) for members with a designation thickness equal to or greater than 54 mils.

Table E7-39
Single L-Header Spans – Gravity Loading
Headers Supporting Two Floors, Roof and Ceiling^{1,2,3}

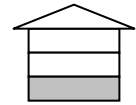

Single L-Header Designation	20 psf Ground Snow Load					30 psf Ground Snow Load				
	Building Width					Building Width				
	24'	28'	32'	36'	40'	24'	28'	32'	36'	40'
600L150-43	1'-11"	1'-10"	1'-8"	1'-7"	1'-7"	1'-11"	1'-10"	1'-8"	1'-7"	1'-6"
600L150-54	2'-8"	2'-6"	2'-4"	2'-3"	2'-2"	2'-8"	2'-6"	2'-4"	2'-3"	2'-1"
600L150-68	3'-1"	2'-11"	2'-9"	2'-7"	2'-6"	3'-1"	2'-11"	2'-7"	2'-7"	2'-6"
800L150-43	2'-4"	2'-2"	2'-1"	1'-11"	1'-10"	2'-4"	2'-2"	2'-1"	1'-11"	1'-10"
800L150-54	3'-3"	3'-0"	2'-10"	2'-8"	2'-7"	3'-2"	3'-0"	2'-10"	2'-8"	2'-7"
800L150-68	3'-9"	3'-6"	3'-3"	3'-1"	3'-0"	3'-8"	3'-6"	3'-3"	3'-1"	2'-11"

For SI: 1 inch = 25.4 mm, 1 mil = 0.0254 mm, 1 psf = 0.0479 kN/m², 1 foot = 0.305 m

¹ Building width is measured in the direction of horizontal framing members supported by the *header*.

² Design assumptions:

Roof and ceiling dead load = 12 psf (0.58 kN/m²) Floor live load = 30 psf (1.44 kN/m²)

2-foot (0.61-m) roof overhang Floor dead load = 10 psf (0.48 kN/m²)

³ The minimum *yield strength*, F_y , of *cold-formed steel* framing members is 50 ksi (340 MPa) for members with a *designation thickness* equal to or greater than 54 mils.

Table E7-40
Single L-Header Spans – Gravity Loading
Headers Supporting Two Floors, Roof and Ceiling^{1,2,3}

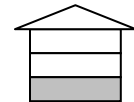

Single L-Header Designation	50 psf Ground Snow Load					70 psf Ground Snow Load				
	Building Width					Building Width				
	24'	28'	32'	36'	40'	24'	28'	32'	36'	40'
600L150-43	1'-11"	1'-9"	1'-8"	1'-7"	1'-6"	1'-10"	1'-9"	1'-7"	1'-6"	1'-6"
600L150-54	2'-7"	2'-5"	2'-3"	2'-2"	2'-1"	2'-6"	2'-5"	2'-3"	1'-1"	2'-0"
600L150-68	3'-0"	2'-10"	2'-8"	2'-6"	2'-5"	2'-11"	2'-9"	2'-7"	2'-6"	2'-4"
800L150-43	2'-3"	2'-1"	2'-0"	1'-11"	1'-10"	2'-3"	2'-1"	1'-11"	1'-10"	1'-9"
800L150-54	3'-2"	2'-11"	2'-9"	2'-7"	2'-6"	3'-1"	2'-10"	2'-8"	2'-7"	2'-5"
800L150-68	3'-7"	3'-5"	3'-2"	3'-0"	2'-10"	3'-6"	3'-4"	3'-1"	2'-11"	2'-10"

For SI: 1 inch = 25.4 mm, 1 mil = 0.0254 mm, 1 psf = 0.0479 kN/m², 1 foot = 0.305 m

¹ Building width is measured in the direction of horizontal framing members supported by the *header*.

² Design assumptions:

Roof and ceiling dead load = 12 psf (0.58 kN/m²) Floor live load = 30 psf (1.44 kN/m²)

2-foot (0.61-m) roof overhang Floor dead load = 10 psf (0.48 kN/m²)

³ The minimum *yield strength*, F_y , of *cold-formed steel* framing members is 50 ksi (340 MPa) for members with a *designation thickness* equal to or greater than 54 mils.

Table E7-41
Inverted Double L-Header Assembly Spans – Uplift Loading
Headers Supporting Roof and Ceiling Only
24-Foot-Wide Building^{1,2,3}

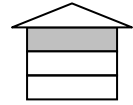

EXPOSURE B	Wind Speed, mph									
	115	120	130	140	150	160	170	180		
EXPOSURE C			115	120	130	140	150	160	170	180
Double L-Header Designation										
2-600L150-43	12'-0"	11'-1"	8'-11"	8'-4"	7'-5"	6'-9"	6'-1"	5'-8"	5'-3"	4'-11"
2-600L150-54	16'-0"	15'-10"	12'-9"	11'-11"	10'-7"	9'-7"	8'-9"	8'-1"	7'-6"	7'-0"
2-600L150-68	16'-0"	16'-0"	14'-9"	13'-10"	12'-4"	11'-1"	10'-2"	9'-4"	8'-8"	8'-2"
2-800L150-43	15'-0"	13'-9"	11'-1"	10'-4"	9'-3"	8'-4"	7'-8"	7'-0"	6'-6"	6'-1"
2-800L150-54	16'-0"	16'-0"	16'-0"	15'-0"	13'-4"	12'-1"	11'-0"	10'-2"	9'-5"	8'-10"
2-800L150-68	16'-0"	16'-0"	16'-0"	16'-0"	15'-5"	13'-11"	12'-9"	11'-9"	10'-11"	10'-2"
2-1000L150-43	15'-8"	14'-5"	11'-7"	10'-10"	9'-8"	8'-9"	8'-0"	7'-4"	6'-10"	6'-5"
2-1000L150-54	16'-0"	16'-0"	16'-0"	15'-4"	13'-8"	12'-4"	11'-3"	10'-4"	9'-8"	9'-0"
2-1000L150-68	16'-0"	16'-0"	16'-0"	16'-0"	16'-0"	14'-6"	13'-3"	12'-3"	11'-5"	10'-8"

For SI: 1 inch = 25.4 mm, 1 mil = 0.0254 mm, 1 mph = 1.61 km/hr = 0.447 m/sec, 1 foot = 0.305 m

¹ Building width is measured in the direction of horizontal framing members supported by the header.

² Design assumptions: Roof and ceiling dead load = 12 psf (0.58 kN/m²), 2 foot roof overhang (0.61 m)

³ The minimum yield strength, F_y , of cold-formed steel framing members is 50 ksi (340 MPa) for members with a designation thickness equal to or greater than 54 mils.

Table E7-42
Inverted Double L-Header Assembly Spans – Uplift Loading
Headers Supporting Roof and Ceiling Only
28-Foot-Wide Building^{1,2,3}

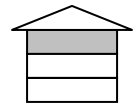

EXPOSURE B	Wind Speed, mph									
	115	120	130	140	150	160	170	180		
EXPOSURE C			115	120	130	140	150	160	170	180
Double L-Header Designation										
2-600L150-43	11'-5"	10'-6"	8'-5"	7'-10"	7'-0"	6'-4"	5'-9"	5'-4"	4'-11"	4'-7"
2-600L150-54	16'-0"	14'-11"	12'-0"	11'-3"	10'-0"	9'-0"	8'-3"	7'-7"	7'-1"	6'-7"
2-600L150-68	16'-0"	16'-0"	13'-11"	13'-1"	11'-7"	10'-6"	9'-7"	8'-10"	8'-2"	7'-8"
2-800L150-43	14'-2"	13'-0"	10'-5"	9'-9"	8'-8"	7'-10"	7'-2"	6'-7"	6'-2"	5'-9"
2-800L150-54	16'-0"	16'-0"	15'-1"	14'-2"	12'-7"	11'-4"	10'-5"	9'-7"	8'-11"	8'-4"
2-800L150-68	16'-0"	16'-0"	16'-0"	16'-0"	14'-7"	13'-2"	12'-0"	11'-1"	10'-3"	9'-7"
2-1000L150-43	14'-10"	13'-8"	10'-11"	10'-3"	9'-1"	8'-3"	7'-6"	6'-11"	6'-5"	6'-0"
2-1000L150-54	16'-0"	16'-0"	15'-5"	14'-6"	12'-10"	11'-7"	10'-7"	9'-9"	9'-1"	8'-6"
2-1000L150-68	16'-0"	16'-0"	16'-0"	16'-0"	15'-2"	13'-8"	12'-6"	11'-6"	10'-9"	10'-0"

For SI: 1 inch = 25.4 mm, 1 mil = 0.0254 mm, 1 mph = 1.61 km/hr = 0.447 m/sec, 1 foot = 0.305 m

¹ Building width is measured in the direction of horizontal framing members supported by the header.

² Design assumptions: Roof and ceiling dead load = 12 psf (0.58 kN/m²), 2-foot (0.61-m) roof overhang.

³ The minimum yield strength, F_y , of cold-formed steel framing members is 50 ksi (340 MPa) for members with a designation thickness equal to or greater than 54 mils.

Table E7-43
Inverted Double L-Header Assembly Spans – Uplift Loading
Headers Supporting Roof and Ceiling Only
32-Foot-Wide Building^{1,2,3}



EXPOSURE B	Wind Speed, mph									
	115	120	130	140	150	160	170	180		
EXPOSURE C			115	120	130	140	150	160	170	180
Double L-Header Designation										
2-600L150-43	10'-10"	9'-11"	8'-0"	7'-5"	6'-8"	6'-0"	5'-6"	5'-0"	4'-8"	4'-4"
2-600L150-54	15'-6"	14'-3"	11'-5"	10'-8"	9'-6"	8'-7"	7'-10"	7'-2"	6'-8"	6'-3"
2-600L150-68	16'-0"	16'-0"	13'-3"	12'-5"	11'-0"	9'-11"	9'-1"	8'-4"	7'-9"	7'-3"
2-800L150-43	13'-6"	12'-5"	9'-11"	9'-4"	8'-3"	7'-5"	6'-10"	6'-3"	5'-10"	5'-5"
2-800L150-54	16'-0"	16'-0"	14'-4"	13'-5"	11'-11"	10'-9"	9'-10"	9'-1"	8'-5"	7'-11"
2-800L150-68	16'-0"	16'-0"	16'-0"	15'-6"	13'-10"	12'-5"	11'-5"	10'-6"	9'-9"	9'-1"
2-1000L150-43	14'-2"	12'-11"	10'-5"	9'-9"	8'-8"	7'-10"	7'-1"	6'-7"	6'-1"	5'-8"
2-1000L150-54	16'-0"	16'-0"	14'-8"	13'-9"	12'-2"	11'-0"	10'-1"	9'-4"	8'-7"	8'-1"
2-1000L150-68	16'-0"	16'-0"	16'-0"	16'-0"	14'-5"	13'-0"	11'-10"	10'-11"	10'-2"	9'-6"

For SI: 1 inch = 25.4 mm, 1 mil = 0.0254 mm, 1 mph = 1.61 km/hr = 0.447 m/sec, 1 foot = 0.305 m

¹ Building width is measured in the direction of horizontal framing members supported by the *header*.

² Design assumptions: Roof and ceiling dead load = 12 psf (0.58 kN/m²), 2-foot (0.61-m) roof overhang.

³ The minimum *yield strength*, F_y , of *cold-formed steel* framing members is 50 ksi (340 MPa) for members with a *designation thickness* equal to or greater than 54 mils.

Table E7-44
Inverted Double L-Header Assembly Spans – Uplift Loading
Headers Supporting Roof and Ceiling Only
36-Foot-Wide Building^{1,2,3}



EXPOSURE B	Wind Speed, mph									
	115	120	130	140	150	160	170	180		
EXPOSURE C			115	120	130	140	150	160	170	180
Double L-Header Designation										
2-600L150-43	10'-4"	9'-6"	7'-7"	7'-1"	6'-4"	5'-8"	5'-2"	4'-10"	4'-5"	4'-2"
2-600L150-54	14'-10"	13'-7"	10'-10"	10'-2"	9'-0"	8'-2"	7'-5"	6'-10"	6'-4"	5'-11"
2-600L150-68	16'-0"	15'-9"	12'-8"	11'-10"	10'-6"	9'-6"	8'-8"	8'-0"	7'-5"	6'-11"
2-800L150-43	12'-11"	11'-10"	9'-6"	8'-10"	7'-10"	7'-1"	6'-6"	6'-0"	5'-7"	5'-2"
2-800L150-54	16'-0"	16'-0"	13'-8"	12'-10"	11'-4"	10'-3"	9'-5"	8'-8"	8'-0"	7'-6"
2-800L150-68	16'-0"	16'-0"	15'-10"	14'-10"	13'-2"	11'-11"	10'-10"	10'-0"	9'-3"	8'-8"
2-1000L150-43	13'-6"	12'-4"	9'-11"	9'-3"	8'-3"	7'-5"	6'-9"	6'-3"	5'-10"	5'-5"
2-1000L150-54	16'-0"	16'-0"	14'-0"	13'-2"	11'-8"	10'-6"	9'-7"	8'-10"	8'-2"	7'-8"
2-1000L150-68	16'-0"	16'-0"	16'-0"	15'-6"	13'-9"	12'-5"	11'-4"	10'-5"	9'-8"	9'-0"

For SI: 1 inch = 25.4 mm, 1 mil = 0.0254 mm, 1 mph = 1.61 km/hr = 0.447 m/sec, 1 foot = 0.305 m

¹ Building width is measured in the direction of horizontal framing members supported by the *header*.

² Design assumptions: Roof and ceiling dead load = 12 psf (0.58 kN/m²), 2-foot (0.61-m) roof overhang.

³ The minimum *yield strength*, F_y , of *cold-formed steel* framing members is 50 ksi (340 MPa) for members with a *designation thickness* equal to or greater than 54 mils.

Table E7-45
Inverted Double L-Header Assembly Spans – Uplift Loading
Headers Supporting Roof and Ceiling Only
40-Foot-Wide Building^{1,2,3}

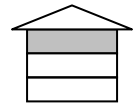

EXPOSURE B	Wind Speed, mph									
	115	120	130	140	150	160	170	180		
EXPOSURE C			115	120	130	140	150	160	170	180
Double L-Header Designation										
2-600L150-43	9'-11"	9'-1"	7'-3"	6'-10"	6'-1"	5'-5"	5'-0"	4'-7"	4'-3"	4'-0"
2-600L150-54	14'-2"	13'-0"	10'-5"	9'-9"	8'-8"	7'-10"	7'-1"	6'-7"	6'-1"	5'-8"
2-600L150-68	16'-0"	15'-1"	12'-1"	11'-4"	10'-1"	9'-1"	8'-3"	7'-8"	7'-1"	6'-7"
2-800L150-43	12'-5"	11'-4"	9'-1"	8'-6"	7'-6"	6'-10"	6'-2"	5'-9"	5'-4"	5'-0"
2-800L150-54	16'-0"	16'-0"	13'-1"	12'-3"	10'-11"	10'-10"	9'-0"	8'-3"	7'-8"	7'-2"
2-800L150-68	16'-0"	16'-0"	15'-2"	14'-2"	12'-7"	11'-4"	10'-5"	9'-7"	8'-11"	8'-3"
2-1000L150-43	12'-11"	11'-10"	9'-6"	8'-11"	7'-11"	7'-1"	6'-6"	6'-0"	5'-7"	5'-2"
2-1000L150-54	16'-0"	16'-0"	13'-5"	12'-7"	11'-2"	10'-1"	9'-2"	8'-5"	7'-10"	7'-4"
2-1000L150-68	16'-0"	16'-0"	15'-10"	14'-10"	13'-2"	11'-11"	10'-10"	10'-0"	9'-3"	8'-8"

For SI: 1 inch = 25.4 mm, 1 mil = 0.0254 mm, 1 mph = 1.61 km/hr = 0.447 m/sec, 1 foot = 0.305 m

¹ Building width is measured in the direction of horizontal framing members supported by the header.

² Design assumptions: Roof and ceiling dead load = 12 psf (0.58 kN/m²), 2-foot (0.61-m) roof overhang.

³ The minimum yield strength, F_y , of cold-formed steel framing members is 50 ksi (340 MPa) for members with a designation thickness equal to or greater than 54 mils.

Table E7-46
Inverted Double L-Header Assembly Spans – Uplift Loading
Headers Supporting One Floor, Roof and Ceiling
24-Foot-Wide Building^{1,2,3,4}

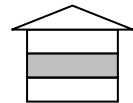

EXPOSURE B	Wind Speed, mph									
	115	120	130	140	150	160	170	180		
EXPOSURE C			115	120	130	140	150	160	170	180
Double L-Header Designation										
2-600L150-43	N/U	N/U	16'-0"	13'-5"	10'-4"	8'-7"	7'-6"	6'-8"	6'-0"	5'-6"
2-600L150-54	N/U	N/U	16'-0"	16'-0"	14'-9"	12'-4"	10'-8"	9'-6"	8'-7"	7'-11"
2-600L150-68	N/U	N/U	16'-0"	16'-0"	16'-0"	14'-4"	12'-5"	11'-1"	10'-0"	9'-2"
2-800L150-43	N/U	N/U	16'-0"	16'-0"	12'-11"	10'-9"	9'-4"	8'-4"	7'-6"	6'-11"
2-800L150-54	N/U	N/U	16'-0"	16'-0"	16'-0"	15'-6"	13'-6"	12'-0"	10'-10"	9'-11"
2-800L150-68	N/U	N/U	16'-0"	16'-0"	16'-0"	16'-0"	15'-7"	13'-10"	12'-6"	11'-6"
2-1000L150-43	N/U	N/U	16'-0"	16'-0"	13'-6"	11'-3"	9'-9"	8'-8"	7'-10"	7'-2"
2-1000L150-54	N/U	N/U	16'-0"	16'-0"	16'-0"	15'-11"	13'-9"	12'-3"	11'-1"	10'-2"
2-1000L150-68	N/U	N/U	16'-0"	16'-0"	16'-0"	16'-0"	16'-0"	14'-5"	13'-1"	12'-0"

For SI: 1 inch = 25.4 mm, 1 mil = 0.0254 mm, 1 mph = 1.61 km/hr = 0.447 m/sec, 1 foot = 0.305 m

¹ Building width is measured in the direction of horizontal framing members supported by the header.

² Design assumptions: Roof and ceiling dead load = 12 psf (0.58 kN/m²) Floor live load = 30 psf (1.44 kN/m²)
Floor dead load = 10 psf (0.48 kN/m²) 2-foot (0.61-m) roof overhang

³ N/U indicates no net uplift loads acting on header. Header need only be selected based on gravity loading.

⁴ The minimum yield strength, F_y , of cold-formed steel framing members is 50 ksi (340 MPa) for members with a designation thickness equal to or greater than 54 mils.

Table E7-47
Inverted Double L-Header Assembly Spans – Uplift Loading
Headers Supporting One Floor, Roof and Ceiling
28-Foot-Wide Building^{1,2,3,4}

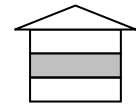

EXPOSURE B	Wind Speed, mph									
	115	120	130	140	150	160	170	180		
EXPOSURE C			115	120	130	140	150	160	170	180
Double L-Header Designation										
2-600L150-43	N/U	N/U	15'-0"	12'-5"	9'-8"	8'-1"	7'-0"	6'-3"	5'-8"	5'-2"
2-600L150-54	N/U	N/U	16'-0"	16'-0"	13'-9"	11'-6"	10'-0"	8'-11"	8'-1"	7'-5"
2-600L150-68	N/U	N/U	16'-0"	16'-0"	16'-0"	13'-5"	11'-8"	10'-4"	9'-5"	8'-7"
2-800L150-43	N/U	N/U	16'-0"	15'-6"	12'-0"	10'-2"	8'-9"	7'-9"	7'-0"	6'-5"
2-800L150-54	N/U	N/U	16'-0"	16'-0"	16'-0"	14'-6"	12'-8"	11'-3"	10'-2"	9'-4"
2-800L150-68	N/U	N/U	16'-0"	16'-0"	16'-0"	16'-0"	14'-7"	13'-0"	11'-9"	10'-9"
2-1000L150-43	N/U	N/U	16'-0"	16'-0"	12'-7"	10'-6"	9'-2"	8'-1"	7'-4"	6'-9"
2-1000L150-54	N/U	N/U	16'-0"	16'-0"	16'-0"	14'-10"	12'-11"	11'-6"	10'-5"	9'-6"
2-1000L150-68	N/U	N/U	16'-0"	16'-0"	16'-0"	16'-0"	15'-3"	13'-7"	12'-3"	11'-3"

For SI: 1 inch = 25.4 mm, 1 mil = 0.0254 mm, 1 mph = 1.61 km/hr = 0.447 m/sec, 1 foot = 0.305 m

- Building width is measured in the direction of horizontal framing members supported by the header.
- Design assumptions: Roof and ceiling dead load = 12 psf (0.58 kN/m²) Floor live load = 30 psf (1.44 kN/m²)
Floor dead load = 10 psf (0.48 kN/m²) 2-foot (0.61-m) roof overhang
- N/U indicates no net uplift loads acting on header. Header need only be selected based on gravity loading.
- The minimum yield strength, F_y , of cold-formed steel framing members is 50 ksi (340 MPa) for members with a designation thickness equal to or greater than 54 mils.

Table E7-48
Inverted Double L-Header Assembly Spans – Uplift Loading
Headers Supporting One Floor, Roof and Ceiling
32-Foot-Wide Building^{1,2,3,4}

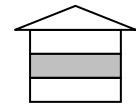

EXPOSURE B	Wind Speed, mph									
	115	120	130	140	150	160	170	180		
EXPOSURE C			115	120	130	140	150	160	170	180
Double L-Header Designation										
2-600L150-43	N/U	N/U	14'-0"	11'-8"	9'-1"	7'-7"	6'-7"	5'-11"	5'-4"	4'-11"
2-600L150-54	N/U	N/U	16'-0"	16'-0"	13'-0"	10'-10"	9'-5"	8'-5"	7'-7"	7'-0"
2-600L150-68	N/U	N/U	16'-0"	16'-0"	15'-1"	12'-8"	11'-0"	9'-9"	8'-10"	8'-1"
2-800L150-43	N/U	N/U	16'-0"	14'-6"	11'-4"	9'-6"	8'-3"	7'-4"	6'-8"	6'-1"
2-800L150-54	N/U	N/U	16'-0"	16'-0"	16'-0"	13'-8"	11'-11"	10'-7"	9'-7"	8'-10"
2-800L150-68	N/U	N/U	16'-0"	16'-0"	16'-0"	15'-10"	13'-9"	12'-3"	11'-1"	10'-2"
2-1000L150-43	N/U	N/U	16'-0"	15'-2"	11'-10"	9'-11"	8'-7"	7'-8"	6'-11"	6'-4"
2-1000L150-54	N/U	N/U	16'-0"	16'-0"	16'-0"	14'-0"	12'-2"	10'-10"	9'-10"	9'-0"
2-1000L150-68	N/U	N/U	16'-0"	16'-0"	16'-0"	16'-0"	14'-4"	12'-10"	11'-7"	10'-7"

For SI: 1 inch = 25.4 mm, 1 mil = 0.0254 mm, 1 mph = 1.61 km/hr = 0.447 m/sec, 1 foot = 0.305 m

- Building width is measured in the direction of horizontal framing members supported by the header.
- Design assumptions: Roof and ceiling dead load = 12 psf (0.58 kN/m²) Floor live load = 30 psf (1.44 kN/m²)
Floor dead load = 10 psf (0.48 kN/m²) 2-foot (0.61-m) roof overhang
- N/U indicates no net uplift loads acting on header. Header need only be selected based on gravity loading.
- The minimum yield strength, F_y , of cold-formed steel framing members is 50 ksi (340 MPa) for members with a designation thickness equal to or greater than 54 mils.

Table E7-49
Inverted Double L-Header Assembly Spans – Uplift Loading
Headers Supporting One Floor, Roof and Ceiling
36-Foot-Wide Building^{1,2,3,4}

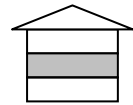

EXPOSURE B	Wind Speed, mph									
	115	120	130	140	150	160	170	180		
EXPOSURE C			115	120	130	140	150	160	170	180
Double L-Header Designation										
2-600L150-43	N/U	N/U	13'-2"	11'-0"	8'-7"	7'-3"	6'-3"	5'-7"	5'-1"	4'-8"
2-600L150-54	N/U	N/U	16'-0"	15'-9"	12'-3"	10'-4"	9'-0"	8'-0"	7'-3"	6'-8"
2-600L150-68	N/U	N/U	16'-0"	16'-0"	14'-3"	12'-0"	10'-5"	9'-4"	8'-5"	7'-9"
2-800L150-43	N/U	N/U	16'-0"	13'-9"	10'-9"	9'-0"	7'-10"	7'-0"	6'-4"	5'-10"
2-800L150-54	N/U	N/U	16'-0"	16'-0"	15'-6"	13'-0"	11'-4"	10'-1"	9'-2"	8'-5"
2-800L150-68	N/U	N/U	16'-0"	16'-0"	16'-0"	15'-0"	13'-1"	11'-8"	10'-7"	9'-8"
2-1000L150-43	N/U	N/U	16'-0"	14'-4"	11'-2"	9'-5"	8'-2"	7'-4"	6'-7"	6'-1"
2-1000L150-54	N/U	N/U	16'-0"	16'-0"	15'-11"	13'-3"	11'-7"	10'-4"	9'-4"	8'-7"
2-1000L150-68	N/U	N/U	16'-0"	16'-0"	16'-0"	15'-8"	13'-8"	12'-2"	11'-0"	10'-1"

For SI: 1 inch = 25.4 mm, 1 mil = 0.0254 mm, 1 mph = 1.61 km/hr = 0.447 m/sec, 1 foot = 0.305 m

- Building width is measured in the direction of horizontal framing members supported by the header.
- Design assumptions: Roof and ceiling dead load = 12 psf (0.58 kN/m²) Floor live load = 30 psf (1.44 kN/m²)
Floor dead load = 10 psf (0.48 kN/m²) 2-foot (0.61-m) roof overhang
- N/U indicates no net uplift loads acting on header. Header need only be selected based on gravity loading.
- The minimum yield strength, F_y , of cold-formed steel framing members is 50 ksi (340 MPa) for members with a designation thickness equal to or greater than 54 mils.

Table E7-50
Inverted Double L-Header Assembly Spans – Uplift Loading
Headers Supporting One Floor, Roof and Ceiling
40-Foot-Wide Building^{1,2,3,4}

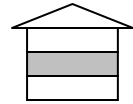

EXPOSURE B	Wind Speed, mph									
	115	120	130	140	150	160	170	180		
EXPOSURE C			115	120	130	140	150	160	170	180
Double L-Header Designation										
2-600L150-43	N/U	N/U	12'-6"	10'-5"	8'-2"	6'-11"	6'-0"	5'-4"	4'-10"	4'-5"
2-600L150-54	N/U	N/U	16'-0"	14'-11"	11'-8"	9'-10"	8'-7"	7'-8"	6'-11"	6'-4"
2-600L150-68	N/U	N/U	16'-0"	16'-0"	13'-7"	11'-5"	9'-11"	8'-11"	8'-1"	7'-4"
2-800L150-43	N/U	N/U	15'-6"	13'-0"	10'-2"	8'-7"	7'-6"	6'-8"	6'-0"	5'-6"
2-800L150-54	N/U	N/U	16'-0"	16'-0"	14'-9"	12'-5"	10'-9"	9'-8"	8'-9"	8'-0"
2-800L150-68	N/U	N/U	16'-0"	16'-0"	16'-0"	14'-4"	12'-6"	11'-1"	10'-1"	9'-3"
2-1000L150-43	N/U	N/U	16'-0"	13'-7"	10'-8"	8'-11"	7'-10"	7'-0"	6'-4"	5'-9"
2-1000L150-54	N/U	N/U	16'-0"	16'-0"	15'-1"	12'-8"	11'-0"	9'-10"	8'-11"	8'-2"
2-1000L150-68	N/U	N/U	16'-0"	16'-0"	16'-0"	14'-11"	13'-0"	11'-7"	10'-6"	9'-8"

For SI: 1 inch = 25.4 mm, 1 mil = 0.0254 mm, 1 mph = 1.61 km/hr = 0.447 m/sec, 1 foot = 0.305 m

- Building width is measured in the direction of horizontal framing members supported by the header.
- Design assumptions: Roof and ceiling dead load = 12 psf (0.58 kN/m²) Floor live load = 30 psf (1.44 kN/m²)
Floor dead load = 10 psf (0.48 kN/m²) 2-foot (0.61-m) roof overhang
- N/U indicates no net uplift loads acting on header. Header need only be selected based on gravity loading.
- The minimum yield strength, F_y , of cold-formed steel framing members is 50 ksi (340 MPa) for members with a designation thickness equal to or greater than 54 mils.

Table E7-51
Inverted Double L-Header Assembly Spans – Uplift Loading
Headers Supporting Two Floors, Roof and Ceiling
24-Foot-Wide Building^{1,2,3,4}

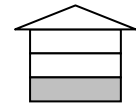

EXPOSURE B	Wind Speed, mph									
	115	120	130	140	150	160	170	180		
EXPOSURE C			115	120	130	140	150	160	170	180
Double L-Header Designation										
2-600L150-43	N/U	N/U	N/U	N/U	16'-0"	14'-9"	10'-6"	8'-6"	7'-4"	6'-5"
2-600L150-54	N/U	N/U	N/U	N/U	16'-0"	16'-0"	15'-1"	12'-2"	10'-5"	9'-3"
2-600L150-68	N/U	N/U	N/U	N/U	16'-0"	16'-0"	16'-0"	14'-2"	12'-2"	10'-9"
2-800L150-43	N/U	N/U	N/U	N/U	16'-0"	16'-0"	13'-1"	10'-8"	9'-1"	8'-0"
2-800L150-54	N/U	N/U	N/U	N/U	16'-0"	16'-0"	16'-0"	15'-4"	13'-2"	11'-7"
2-800L150-68	N/U	N/U	N/U	N/U	16'-0"	16'-0"	16'-0"	16'-0"	15'-3"	13'-5"
2-1000L150-43	N/U	N/U	N/U	N/U	16'-0"	16'-0"	13'-9"	11'-1"	9'-6"	8'-5"
2-1000L150-54	N/U	N/U	N/U	N/U	16'-0"	16'-0"	16'-0"	15'-9"	13'-5"	11'-10"
2-1000L150-68	N/U	N/U	N/U	N/U	16'-0"	16'-0"	16'-0"	16'-0"	15'-10"	14'-0"

For SI: 1 inch = 25.4 mm, 1 mil = 0.0254 mm, 1 mph = 1.61 km/hr = 0.447 m/sec, 1 foot = 0.305 m

- Building width is measured in the direction of horizontal framing members supported by the header.
- Design assumptions: Roof and ceiling dead load = 12 psf (0.58 kN/m²) Floor live load = 30 psf (1.44 kN/m²)
Floor dead load = 10 psf (0.48 kN/m²) 2-foot (0.61-m) roof overhang
- N/U indicates no net uplift loads acting on header. Header need only be selected based on gravity loading.
- The minimum yield strength, F_y , of cold-formed steel framing members is 50 ksi (340 MPa) for members with a designation thickness equal to or greater than 54 mils.

Table E7-52
Inverted Double L-Header Assembly Spans – Uplift Loading
Headers Supporting Two Floors, Roof and Ceiling
28-Foot-Wide Building^{1,2,3,4}

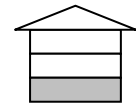

EXPOSURE B	Wind Speed, mph									
	115	120	130	140	150	160	170	180		
EXPOSURE C			115	120	130	140	150	160	170	180
Double L-Header Designation										
2-600L150-43	N/U	N/U	N/U	N/U	16'-0"	13'-4"	9'-8"	7'-11"	6'-10"	6'-0"
2-600L150-54	N/U	N/U	N/U	N/U	16'-0"	16'-0"	13'-10"	11'-4"	9'-9"	8'-7"
2-600L150-68	N/U	N/U	N/U	N/U	16'-0"	16'-0"	16'-0"	13'-2"	11'-4"	10'-0"
2-800L150-43	N/U	N/U	N/U	N/U	16'-0"	16'-0"	12'-1"	9'-10"	8'-6"	7'-6"
2-800L150-54	N/U	N/U	N/U	N/U	16'-0"	16'-0"	16'-0"	14'-3"	12'-3"	10'-10"
2-800L150-68	N/U	N/U	N/U	N/U	16'-0"	16'-0"	16'-0"	16'-0"	14'-2"	12'-6"
2-1000L150-43	N/U	N/U	N/U	N/U	16'-0"	16'-0"	12'-8"	10'-4"	8'-10"	7'-10"
2-1000L150-54	N/U	N/U	N/U	N/U	16'-0"	16'-0"	16'-0"	14'-7"	12'-6"	11'-1"
2-1000L150-68	N/U	N/U	N/U	N/U	16'-0"	16'-0"	16'-0"	16'-0"	14'-9"	13'-1"

For SI: 1 inch = 25.4 mm, 1 mil = 0.0254 mm, 1 mph = 1.61 km/hr = 0.447 m/sec, 1 foot = 0.305 m

- Building width is measured in the direction of horizontal framing members supported by the header.
- Design assumptions: Roof and ceiling dead load = 12 psf (0.58 kN/m²) Floor live load = 30 psf (1.44 kN/m²)
Floor dead load = 10 psf (0.48 kN/m²) 2-foot (0.61-m) roof overhang
- N/U indicates no net uplift loads acting on header. Header need only be selected based on gravity loading.
- The minimum yield strength, F_y , of cold-formed steel framing members is 50 ksi (340 MPa) for members with a designation thickness equal to or greater than 54 mils.

Table E7-53
Inverted Double L-Header Assembly Spans – Uplift Loading
Headers Supporting Two Floors, Roof and Ceiling
32-Foot-Wide Building^{1,2,3,4}

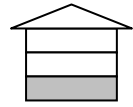

EXPOSURE B	Wind Speed, mph									
	115	120	130	140	150	160	170	180		
EXPOSURE C			115	120	130	140	150	160	170	180
Double L-Header Designation										
2-600L150-43	N/U	N/U	N/U	N/U	16'-0"	12'-3"	9'-1"	7'-5"	6'-5"	5'-9"
2-600L150-54	N/U	N/U	N/U	N/U	16'-0"	16'-0"	12'-11"	10'-7"	9'-2"	8'-1"
2-600L150-68	N/U	N/U	N/U	N/U	16'-0"	16'-0"	15'-0"	12'-4"	10'-8"	9'-5"
2-800L150-43	N/U	N/U	N/U	N/U	16'-0"	15'-3"	11'-3"	9'-3"	8'-0"	7'-1"
2-800L150-54	N/U	N/U	N/U	N/U	16'-0"	16'-0"	16'-0"	13'-4"	11'-6"	10'-2"
2-800L150-68	N/U	N/U	N/U	N/U	16'-0"	16'-0"	16'-0"	15'-5"	13'-4"	11'-10"
2-1000L150-43	N/U	N/U	N/U	N/U	16'-0"	15'-11"	11'-9"	9'-8"	8'-4"	7'-4"
2-1000L150-54	N/U	N/U	N/U	N/U	16'-0"	16'-0"	16'-0"	13'-8"	11'-9"	10'-5"
2-1000L150-68	N/U	N/U	N/U	N/U	16'-0"	16'-0"	16'-0"	16'-0"	13'-11"	12'-4"

For SI: 1 inch = 25.4 mm, 1 mil = 0.0254 mm, 1 mph = 1.61 km/hr = 0.447 m/sec, 1 foot = 0.305 m

- Building width is measured in the direction of horizontal framing members supported by the header.
- Design assumptions: Roof and ceiling dead load = 12 psf (0.58 kN/m²) Floor live load = 30 psf (1.44 kN/m²)
Floor dead load = 10 psf (0.48 kN/m²) 2-foot (0.61-m) roof overhang
- N/U indicates no net uplift loads acting on header. Header need only be selected based on gravity loading.
- The minimum yield strength, F_y , of cold-formed steel framing members is 50 ksi (340 MPa) for members with a designation thickness equal to or greater than 54 mils.

Table E7-54
Inverted Double L-Header Assembly Spans – Uplift Loading
Headers Supporting Two Floors, Roof and Ceiling
36-Foot-Wide Building^{1,2,3,4}

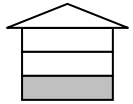

EXPOSURE B	Wind Speed, mph									
	115	120	130	140	150	160	170	180		
EXPOSURE C			115	120	130	140	150	160	170	180
Double L-Header Designation										
2-600L150-43	N/U	N/U	N/U	N/U	16'-0"	11'-5"	8'-6"	7'-0"	6'-1"	5'-4"
2-600L150-54	N/U	N/U	N/U	N/U	16'-0"	16'-0"	12'-2"	10'-0"	8'-8"	7'-8"
2-600L150-68	N/U	N/U	N/U	N/U	16'-0"	16'-0"	14'-1"	11'-8"	10'-1"	8'-11"
2-800L150-43	N/U	N/U	N/U	N/U	16'-0"	14'-2"	10'-7"	8'-9"	7'-6"	6'-8"
2-800L150-54	N/U	N/U	N/U	N/U	16'-0"	16'-0"	15'-4"	12'-7"	10'-11"	9'-8"
2-800L150-68	N/U	N/U	N/U	N/U	16'-0"	16'-0"	16'-0"	14'-7"	12'-7"	11'-2"
2-1000L150-43	N/U	N/U	N/U	N/U	16'-0"	14'-10"	11'-1"	9'-2"	7'-11"	7'-0"
2-1000L150-54	N/U	N/U	N/U	N/U	16'-0"	16'-0"	15'-8"	12'-11"	11'-2"	9'-11"
2-1000L150-68	N/U	N/U	N/U	N/U	16'-0"	16'-0"	16'-0"	15'-2"	13'-2"	11'-8"

For SI: 1 inch = 25.4 mm, 1 mil = 0.0254 mm, 1 mph = 1.61 km/hr = 0.447 m/sec, 1 foot = 0.305 m

- Building width is measured in the direction of horizontal framing members supported by the header.
- Design assumptions: Roof and ceiling dead load = 12 psf (0.58 kN/m²) Floor live load = 30 psf (1.44 kN/m²)
Floor dead load = 10 psf (0.48 kN/m²) 2-foot (0.61-m) roof overhang
- N/U indicates no net uplift loads acting on header. Header need only be selected based on gravity loading.
- The minimum yield strength, F_y , of cold-formed steel framing members is 50 ksi (340 MPa) for members with a designation thickness equal to or greater than 54 mils.

Table E7-55
Inverted Double L-Header Assembly Spans – Uplift Loading
Headers Supporting Two Floors, Roof and Ceiling
40-Foot-Wide Building^{1,2,3,4}

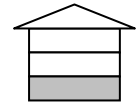

EXPOSURE B	Wind Speed, mph									
	115	120	130	140	150	160	170	180		
EXPOSURE C			115	120	130	140	150	160	170	180
Double L-Header Designation										
2-600L150-43	N/U	N/U	N/U	N/U	16'-0"	10'-8"	8'-1"	6'-8"	5'-9"	5'-1"
2-600L150-54	N/U	N/U	N/U	N/U	16'-0"	15'-3"	11'-6"	9'-6"	8'-3"	7'-4"
2-600L150-68	N/U	N/U	N/U	N/U	16'-0"	16'-0"	13'-4"	11'-1"	9'-7"	8'-6"
2-800L150-43	N/U	N/U	N/U	N/U	16'-0"	13'-4"	10'-0"	8'-3"	7'-2"	6'-4"
2-800L150-54	N/U	N/U	N/U	N/U	16'-0"	16'-0"	14'-6"	12'-0"	10'-4"	9'-2"
2-800L150-68	N/U	N/U	N/U	N/U	16'-0"	16'-0"	16'-0"	13'-11"	12'-0"	10'-8"
2-1000L150-43	N/U	N/U	N/U	N/U	16'-0"	13'-11"	10'-6"	8'-8"	7'-6"	6'-8"
2-1000L150-54	N/U	N/U	N/U	N/U	16'-0"	16'-0"	14'-10"	12'-3"	10'-7"	9'-5"
2-1000L150-68	N/U	N/U	N/U	N/U	16'-0"	16'-0"	16'-0"	14'-5"	12'-6"	11'-1"

For SI: 1 inch = 25.4 mm, 1 mil = 0.0254 mm, 1 mph = 1.61 km/hr = 0.447 m/sec, 1 foot = 0.305 m

- ¹ Building width is measured in the direction of horizontal framing members supported by the header.
- ² Design assumptions: Roof and ceiling dead load = 12 psf (0.58 kN/m²) Floor live load = 30 psf (1.44 kN/m²)
Floor dead load = 10 psf (0.48 kN/m²) 2-foot (0.61-m) roof overhang
- ³ N/U indicates no net uplift loads acting on header. Header need only be selected based on gravity loading.
- ⁴ The minimum yield strength, F_y , of cold-formed steel framing members is 50 ksi (340 MPa) for members with a designation thickness equal to or greater than 54 mils.

Table E7-56
Inverted Single L-Header Assembly Spans – Uplift Loading
Headers Supporting Roof and Ceiling Only
24-Foot-Wide Building^{1,2,3}

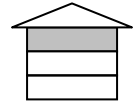

EXPOSURE B	Wind Speed, mph									
	115	120	130	140	150	160	170	180		
EXPOSURE C			115	120	130	140	150	160	170	180
Single L-Header Designation										
600L150-43	4'-0"	4'-0"	4'-0"	4'-0"	4'-0"	4'-0"	3'-11"	3'-7"	3'-4"	3'-2"
600L150-54	4'-0"	4'-0"	4'-0"	4'-0"	4'-0"	4'-0"	4'-0"	4'-0"	4'-0"	4'-0"
600L150-68	4'-0"	4'-0"	4'-0"	4'-0"	4'-0"	4'-0"	4'-0"	4'-0"	4'-0"	4'-0"
800L150-43	4'-0"	4'-0"	4'-0"	4'-0"	4'-0"	4'-0"	4'-0"	4'-0"	4'-0"	3'-9"
800L150-54	4'-0"	4'-0"	4'-0"	4'-0"	4'-0"	4'-0"	4'-0"	4'-0"	4'-0"	4'-0"
800L150-68	4'-0"	4'-0"	4'-0"	4'-0"	4'-0"	4'-0"	4'-0"	4'-0"	4'-0"	4'-0"

For SI: 1 inch = 25.4 mm, 1 mil = 0.0254 mm, 1 mph = 1.61 km/hr = 0.447 m/sec, 1 foot = 0.305 m

¹ Building width is measured in the direction of horizontal framing members supported by the header.

² Design assumptions: Roof and ceiling dead load = 12 psf (0.58 kN/m²), 2 foot roof overhang (0.61 m).

³ The minimum yield strength, F_y , of cold-formed steel framing members is 50 ksi (340 MPa) for members with a designation thickness equal to or greater than 54 mils.

Table E7-57
Inverted Single L-Header Assembly Spans – Uplift Loading
Headers Supporting Roof and Ceiling Only
28-Foot-Wide Building^{1,2,3}

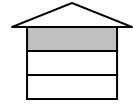

EXPOSURE B	Wind Speed, mph									
	115	120	130	140	150	160	170	180		
EXPOSURE C			115	120	130	140	150	160	170	180
Single L-Header Designation										
600L150-43	4'-0"	4'-0"	4'-0"	4'-0"	4'-0"	4'-0"	3'-8"	3'-5"	3'-2"	2'-11"
600L150-54	4'-0"	4'-0"	4'-0"	4'-0"	4'-0"	4'-0"	4'-0"	4'-0"	4'-0"	4'-0"
600L150-68	4'-0"	4'-0"	4'-0"	4'-0"	4'-0"	4'-0"	4'-0"	4'-0"	4'-0"	4'-0"
800L150-43	4'-0"	4'-0"	4'-0"	4'-0"	4'-0"	4'-0"	4'-0"	4'-0"	3'-10"	3'-7"
800L150-54	4'-0"	4'-0"	4'-0"	4'-0"	4'-0"	4'-0"	4'-0"	4'-0"	4'-0"	4'-0"
800L150-68	4'-0"	4'-0"	4'-0"	4'-0"	4'-0"	4'-0"	4'-0"	4'-0"	4'-0"	4'-0"

For SI: 1 inch = 25.4 mm, 1 mil = 0.0254 mm, 1 mph = 1.61 km/hr = 0.447 m/sec, 1 foot = 0.305 m

¹ Building width is measured in the direction of horizontal framing members supported by the header.

² Design assumptions: Roof and ceiling dead load = 12 psf (0.58 kN/m²), 2-foot (0.61-m) roof overhang.

³ The minimum yield strength, F_y , of cold-formed steel framing members is 50 ksi (340 MPa) for members with a designation thickness equal to or greater than 54 mils.

Table E7-58
Inverted Single L-Header Assembly Spans – Uplift Loading
Headers Supporting Roof and Ceiling Only
32-Foot-Wide Building^{1,2,3}

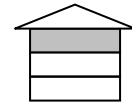

EXPOSURE B	Wind Speed, mph									
	115	120	130	140	150	160	170	180		
EXPOSURE C			115	120	130	140	150	160	170	180
Single L-Header Designation										
600L150-43	4'-0"	4'-0"	4'-0"	4'-0"	4'-0"	3'-10"	3'-6"	3'-3"	3'-0"	2'-10"
600L150-54	4'-0"	4'-0"	4'-0"	4'-0"	4'-0"	4'-0"	4'-0"	4'-0"	4'-0"	4'-0"
600L150-68	4'-0"	4'-0"	4'-0"	4'-0"	4'-0"	4'-0"	4'-0"	4'-0"	4'-0"	4'-0"
800L150-43	4'-0"	4'-0"	4'-0"	4'-0"	4'-0"	4'-0"	4'-0"	3'-11"	3'-7"	3'-4"
800L150-54	4'-0"	4'-0"	4'-0"	4'-0"	4'-0"	4'-0"	4'-0"	4'-0"	4'-0"	4'-0"
800L150-68	4'-0"	4'-0"	4'-0"	4'-0"	4'-0"	4'-0"	4'-0"	4'-0"	4'-0"	4'-0"

For SI: 1 inch = 25.4 mm, 1 mil = 0.0254 mm, 1 mph = 1.61 km/hr = 0.447 m/sec, 1 foot = 0.305 m

¹ Building width is measured in the direction of horizontal framing members supported by the header.

² Design assumptions: Roof and ceiling dead load = 12 psf (0.58 kN/m²), 2-foot (0.61-m) roof overhang.

³ The minimum yield strength, F_y , of cold-formed steel framing members is 50 ksi (340 MPa) for members with a designation thickness equal to or greater than 54 mils.

Table E7-59
Inverted Single L-Header Assembly Spans – Uplift Loading
Headers Supporting Roof and Ceiling Only
36-Foot-Wide Building^{1,2,3}

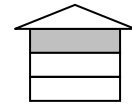

EXPOSURE B	Wind Speed, mph									
	115	120	130	140	150	160	170	180		
EXPOSURE C			115	120	130	140	150	160	170	180
Single L-Header Designation										
600L150-43	4'-0"	4'-0"	4'-0"	4'-0"	4'-0"	3'-8"	3'-4"	3'-1"	2'-10"	2'-8"
600L150-54	4'-0"	4'-0"	4'-0"	4'-0"	4'-0"	4'-0"	4'-0"	4'-0"	4'-0"	4'-0"
600L150-68	4'-0"	4'-0"	4'-0"	4'-0"	4'-0"	4'-0"	4'-0"	4'-0"	4'-0"	4'-0"
800L150-43	4'-0"	4'-0"	4'-0"	4'-0"	4'-0"	4'-0"	4'-0"	3'-8"	3'-5"	3'-2"
800L150-54	4'-0"	4'-0"	4'-0"	4'-0"	4'-0"	4'-0"	4'-0"	4'-0"	4'-0"	4'-0"
800L150-68	4'-0"	4'-0"	4'-0"	4'-0"	4'-0"	4'-0"	4'-0"	4'-0"	4'-0"	4'-0"

For SI: 1 inch = 25.4 mm, 1 mil = 0.0254 mm, 1 mph = 1.61 km/hr = 0.447 m/sec, 1 foot = 0.305 m

¹ Building width is measured in the direction of horizontal framing members supported by the header.

² Design assumptions: Roof and ceiling dead load = 12 psf (0.58 kN/m²), 2-foot (0.61-m) roof overhang

³ The minimum yield strength, F_y , of cold-formed steel framing members is 50 ksi (340 MPa) for members with a designation thickness equal to or greater than 54 mils.

Table E7-60
Inverted Single L-Header Assembly Spans – Uplift Loading
Headers Supporting Roof and Ceiling Only
40-Foot-Wide Building^{1,2,3}

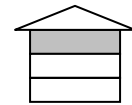

EXPOSURE B	Wind Speed, mph									
	115	120	130	140	150	160	170	180		
EXPOSURE C			115	120	130	140	150	160	170	180
Single L-Header Designation										
600L150-43	4'-0"	4'-0"	4'-0"	4'-0"	3'-10"	3'-6"	3'-2"	2'-11"	2'-9"	2'-7"
600L150-54	4'-0"	4'-0"	4'-0"	4'-0"	4'-0"	4'-0"	4'-0"	4'-0"	3'-11"	3'-8"
600L150-68	4'-0"	4'-0"	4'-0"	4'-0"	4'-0"	4'-0"	4'-0"	4'-0"	4'-0"	4'-0"
800L150-43	4'-0"	4'-0"	4'-0"	4'-0"	4'-0"	4'-0"	3'-10"	3'-6"	3'-3"	3'-1"
800L150-54	4'-0"	4'-0"	4'-0"	4'-0"	4'-0"	4'-0"	4'-0"	4'-0"	4'-0"	4'-0"
800L150-68	4'-0"	4'-0"	4'-0"	4'-0"	4'-0"	4'-0"	4'-0"	4'-0"	4'-0"	4'-0"

For SI: 1 inch = 25.4 mm, 1 mil = 0.0254 mm, 1 mph = 1.61 km/hr = 0.447 m/sec, 1 foot = 0.305 m

¹ Building width is measured in the direction of horizontal framing members supported by the header.

² Design assumptions: Roof and ceiling dead load = 12 psf (0.58 kN/m²), 2-foot (0.61-m) roof overhang.

³ The minimum yield strength, F_y , of cold-formed steel framing members is 50 ksi (340 MPa) for members with a designation thickness equal to or greater than 54 mils.

Table E7-61
Inverted Single L-Header Assembly Spans – Uplift Loading
Headers Supporting One Floor, Roof and Ceiling
24-Foot-Wide Building^{1,2,3,4}

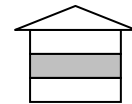

EXPOSURE B	Wind Speed, mph									
	115	120	130	140	150	160	170	180		
EXPOSURE C			115	120	130	140	150	160	170	180
Single L-Header Designation										
600L150-43	N/U	N/U	4'-0"	4'-0"	4'-0"	4'-0"	4'-0"	4'-0"	3'-10"	3'-6"
600L150-54	N/U	N/U	4'-0"	4'-0"	4'-0"	4'-0"	4'-0"	4'-0"	4'-0"	4'-0"
600L150-68	N/U	N/U	4'-0"	4'-0"	4'-0"	4'-0"	4'-0"	4'-0"	4'-0"	4'-0"
800L150-43	N/U	N/U	4'-0"	4'-0"	4'-0"	4'-0"	4'-0"	4'-0"	4'-0"	4'-0"
800L150-54	N/U	N/U	4'-0"	4'-0"	4'-0"	4'-0"	4'-0"	4'-0"	4'-0"	4'-0"
800L150-68	N/U	N/U	4'-0"	4'-0"	4'-0"	4'-0"	4'-0"	4'-0"	4'-0"	4'-0"

For SI: 1 inch = 25.4 mm, 1 mil = 0.0254 mm, 1 mph = 1.61 km/hr = 0.447 m/sec, 1 foot = 0.305 m

¹ Building width is measured in the direction of horizontal framing members supported by the header.

² Design assumptions: Roof and ceiling dead load = 12 psf (0.58 kN/m²) Floor live load = 30 psf (1.44 kN/m²)
 Floor dead load = 10 psf (0.48 kN/m²) 2-foot (0.61-m) roof overhang

³ N/U indicates no net uplift loads acting on header. Header need only be selected based on gravity loading.

⁴ The minimum yield strength, F_y , of cold-formed steel framing members is 50 ksi (340 MPa) for members with a designation thickness equal to or greater than 54 mils.

Table E7-62
Inverted Single L-Header Assembly Spans – Uplift Loading
Headers Supporting One Floor, Roof and Ceiling
28-Foot-Wide Building ^{1,2,3,4}

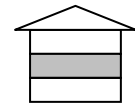

EXPOSURE B	Wind Speed, mph										
	115	120	130	140	150	160	170	180			
EXPOSURE C			115	120	130	140	150	160	170	180	
Single L-Header Designation											
600L150-43	N/U	N/U	4'-0"	4'-0"	4'-0"	4'-0"	4'-0"	4'-0"	4'-0"	3'-7"	3'-4"
600L150-54	N/U	N/U	4'-0"	4'-0"	4'-0"	4'-0"	4'-0"	4'-0"	4'-0"	4'-0"	4'-0"
600L150-68	N/U	N/U	4'-0"	4'-0"	4'-0"	4'-0"	4'-0"	4'-0"	4'-0"	4'-0"	4'-0"
800L150-43	N/U	N/U	4'-0"	4'-0"	4'-0"	4'-0"	4'-0"	4'-0"	4'-0"	4'-0"	4'-0"
800L150-54	N/U	N/U	4'-0"	4'-0"	4'-0"	4'-0"	4'-0"	4'-0"	4'-0"	4'-0"	4'-0"
800L150-68	N/U	N/U	4'-0"	4'-0"	4'-0"	4'-0"	4'-0"	4'-0"	4'-0"	4'-0"	4'-0"

For SI: 1 inch = 25.4 mm, 1 mil = 0.0254 mm, 1 mph = 1.61 km/hr = 0.447 m/sec, 1 foot = 0.305 m

¹ Building width is measured in the direction of horizontal framing members supported by the header.

² Design assumptions: Roof and ceiling dead load = 12 psf (0.58 kN/m²) Floor live load = 30 psf (1.44 kN/m²)
 Floor dead load = 10 psf (0.48 kN/m²) 2-foot (0.61-m) roof overhang

³ N/U indicates no net uplift loads acting on header. Header need only be selected based on gravity loading.

⁴ The minimum yield strength, F_y , of cold-formed steel framing members is 50 ksi (340 MPa) for members with a designation thickness equal to or greater than 54 mils.

Table E7-63
Inverted Single L-Header Assembly Spans – Uplift Loading
Headers Supporting One Floor, Roof and Ceiling
32-Foot-Wide Building ^{1,2,3,4}

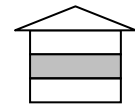

EXPOSURE B	Wind Speed, mph										
	115	120	130	140	150	160	170	180			
EXPOSURE C			115	120	130	140	150	160	170	180	
Single L-Header Designation											
600L150-43	N/U	N/U	4'-0"	4'-0"	4'-0"	4'-0"	4'-0"	4'-0"	3'-9"	3'-5"	3'-1"
600L150-54	N/U	N/U	4'-0"	4'-0"	4'-0"	4'-0"	4'-0"	4'-0"	4'-0"	4'-0"	4'-0"
600L150-68	N/U	N/U	4'-0"	4'-0"	4'-0"	4'-0"	4'-0"	4'-0"	4'-0"	4'-0"	4'-0"
800L150-43	N/U	N/U	4'-0"	4'-0"	4'-0"	4'-0"	4'-0"	4'-0"	4'-0"	4'-0"	3'-9"
800L150-54	N/U	N/U	4'-0"	4'-0"	4'-0"	4'-0"	4'-0"	4'-0"	4'-0"	4'-0"	4'-0"
800L150-68	N/U	N/U	4'-0"	4'-0"	4'-0"	4'-0"	4'-0"	4'-0"	4'-0"	4'-0"	4'-0"

For SI: 1 inch = 25.4 mm, 1 mil = 0.0254 mm, 1 mph = 1.61 km/hr = 0.447 m/sec, 1 foot = 0.305 m

¹ Building width is measured in the direction of horizontal framing members supported by the header.

² Design assumptions: Roof and ceiling dead load = 12 psf (0.58 kN/m²) Floor live load = 30 psf (1.44 kN/m²)
 Floor dead load = 10 psf (0.48 kN/m²) 2-foot (0.61-m) roof overhang

³ N/U indicates no net uplift loads acting on header. Header need only be selected based on gravity loading.

⁴ The minimum yield strength, F_y , of cold-formed steel framing members is 50 ksi (340 MPa) for members with a designation thickness equal to or greater than 54 mils.

Table E7-64
Inverted Single L-Header Assembly Spans – Uplift Loading
Headers Supporting One Floor, Roof and Ceiling
36-Foot-Wide Building ^{1,2,3,4}

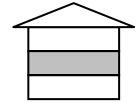

EXPOSURE B	Wind Speed, mph									
	115	120	130	140	150	160	170	180		
EXPOSURE C			115	120	130	140	150	160	170	180
Single L-Header Designation										
600L150-43	N/U	N/U	4'-0"	4'-0"	4'-0"	4'-0"	4'-0"	3'-8"	3'-3"	3'-0"
600L150-54	N/U	N/U	4'-0"	4'-0"	4'-0"	4'-0"	4'-0"	4'-0"	4'-0"	4'-0"
600L150-68	N/U	N/U	4'-0"	4'-0"	4'-0"	4'-0"	4'-0"	4'-0"	4'-0"	4'-0"
800L150-43	N/U	N/U	4'-0"	4'-0"	4'-0"	4'-0"	4'-0"	4'-0"	3'-11"	3'-7"
800L150-54	N/U	N/U	4'-0"	4'-0"	4'-0"	4'-0"	4'-0"	4'-0"	4'-0"	4'-0"
800L150-68	N/U	N/U	4'-0"	4'-0"	4'-0"	4'-0"	4'-0"	4'-0"	4'-0"	4'-0"

For SI: 1 inch = 25.4 mm, 1 mil = 0.0254 mm, 1 mph = 1.61 km/hr = 0.447 m/sec, 1 foot = 0.305 m

¹ Building width is measured in the direction of horizontal framing members supported by the header.

² Design assumptions: Roof and ceiling dead load = 12 psf (0.58 kN/m²) Floor live load = 30 psf (1.44 kN/m²)
 Floor dead load = 10 psf (0.48 kN/m²) 2-foot (0.61-m) roof overhang

³ N/U indicates no net uplift loads acting on header. Header need only be selected based on gravity loading.

⁴ The minimum yield strength, F_y , of cold-formed steel framing members is 50 ksi (340 MPa) for members with a designation thickness equal to or greater than 54 mils.

Table E7-65
Inverted Single L-Header Assembly Spans – Uplift Loading
Headers Supporting One Floor, Roof and Ceiling
40-Foot-Wide Building ^{1,2,3,4}

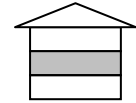

EXPOSURE B	Wind Speed, mph									
	115	120	130	140	150	160	170	180		
EXPOSURE C			115	120	130	140	150	160	170	180
Single L-Header Designation										
600L150-43	N/U	N/U	4'-0"	4'-0"	4'-0"	4'-0"	3'-10"	3'-5"	3'-1"	2'-10"
600L150-54	N/U	N/U	4'-0"	4'-0"	4'-0"	4'-0"	4'-0"	4'-0"	4'-0"	4'-0"
600L150-68	N/U	N/U	4'-0"	4'-0"	4'-0"	4'-0"	4'-0"	4'-0"	4'-0"	4'-0"
800L150-43	N/U	N/U	4'-0"	4'-0"	4'-0"	4'-0"	4'-0"	4'-0"	3'-9"	3'-5"
800L150-54	N/U	N/U	4'-0"	4'-0"	4'-0"	4'-0"	4'-0"	4'-0"	4'-0"	4'-0"
800L150-68	N/U	N/U	4'-0"	4'-0"	4'-0"	4'-0"	4'-0"	4'-0"	4'-0"	4'-0"

For SI: 1 inch = 25.4 mm, 1 mil = 0.0254 mm, 1 mph = 1.61 km/hr = 0.447 m/sec, 1 foot = 0.305 m

¹ Building width is measured in the direction of horizontal framing members supported by the header.

² Design assumptions: Roof and ceiling dead load = 12 psf (0.58 kN/m²) Floor live load = 30 psf (1.44 kN/m²)
 Floor dead load = 10 psf (0.48 kN/m²) 2-foot (0.61-m) roof overhang

³ N/U indicates no net uplift loads acting on header. Header need only be selected based on gravity loading.

⁴ The minimum yield strength, F_y , of cold-formed steel framing members is 50 ksi (340 MPa) for members with a designation thickness equal to or greater than 54 mils.

Table E7-66
Inverted Single L-Header Assembly Spans – Uplift Loading
Headers Supporting Two Floors, Roof and Ceiling
24-Foot-Wide Building^{1,2,3,4}

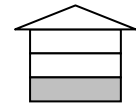

EXPOSURE B	Wind Speed, mph									
	115	120	130	140	150	160	170	180		
EXPOSURE C			115	120	130	140	150	160	170	180
Single L-Header Designation										
600L150-43	N/U	N/U	N/U	N/U	4'-0"	4'-0"	4'-0"	4'-0"	4'-0"	4'-0"
600L150-54	N/U	N/U	N/U	N/U	4'-0"	4'-0"	4'-0"	4'-0"	4'-0"	4'-0"
600L150-68	N/U	N/U	N/U	N/U	4'-0"	4'-0"	4'-0"	4'-0"	4'-0"	4'-0"
800L150-43	N/U	N/U	N/U	N/U	4'-0"	4'-0"	4'-0"	4'-0"	4'-0"	4'-0"
800L150-54	N/U	N/U	N/U	N/U	4'-0"	4'-0"	4'-0"	4'-0"	4'-0"	4'-0"
800L150-68	N/U	N/U	N/U	N/U	4'-0"	4'-0"	4'-0"	4'-0"	4'-0"	4'-0"

For SI: 1 inch = 25.4 mm, 1 mil = 0.0254 mm, 1 mph = 1.61 km/hr = 0.447 m/sec, 1 foot = 0.305 m

¹ Building width is measured in the direction of horizontal framing members supported by the header.

² Design assumptions: Roof and ceiling dead load = 12 psf (0.58 kN/m²) Floor live load = 30 psf (1.44 kN/m²)
 Floor dead load = 10 psf (0.48 kN/m²) 2-foot (0.61-m) roof overhang

³ N/U indicates no net uplift loads acting on header. Header need only be selected based on gravity loading.

⁴ The minimum yield strength, F_y , of cold-formed steel framing members is 50 ksi (340 MPa) for members with a designation thickness equal to or greater than 54 mils.

Table E7-67
Inverted Single L-Header Assembly Spans – Uplift Loading
Headers Supporting Two Floors, Roof and Ceiling
28-Foot-Wide Building^{1,2,3,4}

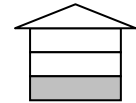

EXPOSURE B	Wind Speed, mph									
	115	120	130	140	150	160	170	180		
EXPOSURE C			115	120	130	140	150	160	170	180
Single L-Header Designation										
600L150-43	N/U	N/U	N/U	N/U	4'-0"	4'-0"	4'-0"	4'-0"	4'-0"	3'-10"
600L150-54	N/U	N/U	N/U	N/U	4'-0"	4'-0"	4'-0"	4'-0"	4'-0"	4'-0"
600L150-68	N/U	N/U	N/U	N/U	4'-0"	4'-0"	4'-0"	4'-0"	4'-0"	4'-0"
800L150-43	N/U	N/U	N/U	N/U	4'-0"	4'-0"	4'-0"	4'-0"	4'-0"	4'-0"
800L150-54	N/U	N/U	N/U	N/U	4'-0"	4'-0"	4'-0"	4'-0"	4'-0"	4'-0"
800L150-68	N/U	N/U	N/U	N/U	4'-0"	4'-0"	4'-0"	4'-0"	4'-0"	4'-0"

For SI: 1 inch = 25.4 mm, 1 mil = 0.0254 mm, 1 mph = 1.61 km/hr = 0.447 m/sec, 1 foot = 0.305 m

¹ Building width is measured in the direction of horizontal framing members supported by the header.

² Design assumptions: Roof and ceiling dead load = 12 psf (0.58 kN/m²) Floor live load = 30 psf (1.44 kN/m²)
 Floor dead load = 10 psf (0.48 kN/m²) 2-foot (0.61-m) roof overhang

³ N/U indicates no net uplift loads acting on header. Header need only be selected based on gravity loading.

⁴ The minimum yield strength, F_y , of cold-formed steel framing members is 50 ksi (340 MPa) for members with a designation thickness equal to or greater than 54 mils.

Table E7-68
Inverted Single L-Header Assembly Spans – Uplift Loading
Headers Supporting Two Floors, Roof and Ceiling
32-Foot-Wide Building^{1,2,3,4}

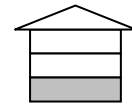

EXPOSURE B	Wind Speed, mph									
	115	120	130	140	150	160	170	180		
EXPOSURE C			115	120	130	140	150	160	170	180
Single L-Header Designation										
600L150-43	N/U	N/U	N/U	N/U	4'-0"	4'-0"	4'-0"	4'-0"	4'-0"	3'-7"
600L150-54	N/U	N/U	N/U	N/U	4'-0"	4'-0"	4'-0"	4'-0"	4'-0"	4'-0"
600L150-68	N/U	N/U	N/U	N/U	4'-0"	4'-0"	4'-0"	4'-0"	4'-0"	4'-0"
800L150-43	N/U	N/U	N/U	N/U	4'-0"	4'-0"	4'-0"	4'-0"	4'-0"	4'-0"
800L150-54	N/U	N/U	N/U	N/U	4'-0"	4'-0"	4'-0"	4'-0"	4'-0"	4'-0"
800L150-68	N/U	N/U	N/U	N/U	4'-0"	4'-0"	4'-0"	4'-0"	4'-0"	4'-0"

For SI: 1 inch = 25.4 mm, 1 mil = 0.0254 mm, 1 mph = 1.61 km/hr = 0.447 m/sec, 1 foot = 0.305 m

¹ Building width is measured in the direction of horizontal framing members supported by the header.

² Design assumptions: Roof and ceiling dead load = 12 psf (0.58 kN/m²) Floor live load = 30 psf (1.44 kN/m²)
 Floor dead load = 10 psf (0.48 kN/m²) 2-foot (0.61-m) roof overhang

³ N/U indicates no net uplift loads acting on header. Header need only be selected based on gravity loading.

⁴ The minimum yield strength, F_y , of cold-formed steel framing members is 50 ksi (340 MPa) for members with a designation thickness equal to or greater than 54 mils.

Table E7-69
Inverted Single L-Header Assembly Spans – Uplift Loading
Headers Supporting Two Floors, Roof and Ceiling
36-Foot-Wide Building^{1,2,3,4}

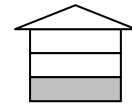

EXPOSURE B	Wind Speed, mph									
	115	120	130	140	150	160	170	180		
EXPOSURE C			115	120	130	140	150	160	170	180
Single L-Header Designation										
600L150-43	N/U	N/U	N/U	N/U	4'-0"	4'-0"	4'-0"	4'-0"	3'-10"	3'-5"
600L150-54	N/U	N/U	N/U	N/U	4'-0"	4'-0"	4'-0"	4'-0"	4'-0"	4'-0"
600L150-68	N/U	N/U	N/U	N/U	4'-0"	4'-0"	4'-0"	4'-0"	4'-0"	4'-0"
800L150-43	N/U	N/U	N/U	N/U	4'-0"	4'-0"	4'-0"	4'-0"	4'-0"	4'-0"
800L150-54	N/U	N/U	N/U	N/U	4'-0"	4'-0"	4'-0"	4'-0"	4'-0"	4'-0"
800L150-68	N/U	N/U	N/U	N/U	4'-0"	4'-0"	4'-0"	4'-0"	4'-0"	4'-0"

For SI: 1 inch = 25.4 mm, 1 mil = 0.0254 mm, 1 mph = 1.61 km/hr = 0.447 m/sec, 1 foot = 0.305 m

¹ Building width is measured in the direction of horizontal framing members supported by the header.

² Design assumptions: Roof and ceiling dead load = 12 psf (0.58 kN/m²) Floor live load = 30 psf (1.44 kN/m²)
 Floor dead load = 10 psf (0.48 kN/m²) 2-foot (0.61-m) roof overhang

³ N/U indicates no net uplift loads acting on header. Header need only be selected based on gravity loading.

⁴ The minimum yield strength, F_y , of cold-formed steel framing members is 50 ksi (340 MPa) for members with a designation thickness equal to or greater than 54 mils.

Table E7-70
Inverted Single L-Header Assembly Spans – Uplift Loading
Headers Supporting Two Floors, Roof and Ceiling
40-Foot-Wide Building^{1,2,3,4}

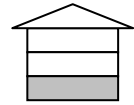

EXPOSURE B	Wind Speed, mph									
	115	120	130	140	150	160	170	180		
EXPOSURE C			115	120	130	140	150	160	170	180
Single L-Header Designation										
600L150-43	N/U	N/U	N/U	N/U	4'-0"	4'-0"	4'-0"	4'-0"	3'-8"	3'-3"
600L150-54	N/U	N/U	N/U	N/U	4'-0"	4'-0"	4'-0"	4'-0"	4'-0"	4'-0"
600L150-68	N/U	N/U	N/U	N/U	4'-0"	4'-0"	4'-0"	4'-0"	4'-0"	4'-0"
800L150-43	N/U	N/U	N/U	N/U	4'-0"	4'-0"	4'-0"	4'-0"	4'-0"	3'-11"
800L150-54	N/U	N/U	N/U	N/U	4'-0"	4'-0"	4'-0"	4'-0"	4'-0"	4'-0"
800L150-68	N/U	N/U	N/U	N/U	4'-0"	4'-0"	4'-0"	4'-0"	4'-0"	4'-0"

For SI: 1 inch = 25.4 mm, 1 mil = 0.0254 mm, 1 mph = 1.61 km/hr = 0.447 m/sec, 1 foot = 0.305 m

¹ Building width is measured in the direction of horizontal framing members supported by the header.

² Design assumptions: Roof and ceiling dead load = 12 psf (0.58 kN/m²) Floor live load = 30 psf (1.44 kN/m²)
Floor dead load = 10 psf (0.48 kN/m²) 2-foot (0.61-m) roof overhang

³ N/U indicates no net uplift loads acting on header. Header need only be selected based on gravity loading.

⁴ The minimum yield strength, F_y , of cold-formed steel framing members is 50 ksi (340 MPa) for members with a designation thickness equal to or greater than 54 mils.

Table E7-71
Jack and King Studs Required at Each End of an Opening

Size of Opening	24-inch o.c. Stud Spacing		16-inch o.c. Stud Spacing	
	No. of Jack Studs	No. of King Studs	No. of Jack Studs	No. of King Studs
Up to 3'-6"	1	1	1	1
> 3'-6" to 5'-0"	1	2	1	2
> 5'-0" to 5'-6"	1	2	2	2
> 5'-6" to 8'-0"	1	2	2	2
> 8'-0" to 10'-6"	2	2	2	3
> 10'-6" to 12'-0"	2	2	3	3
> 12'-0" to 13'-0"	2	3	3	3
> 13'-0" to 14'-0"	2	3	3	4
> 14'-0" to 16'-0"	2	3	3	4
> 16'-0" to 18'-0"	3	3	4	4

For SI: 1 inch = 25.4 mm, 1 foot = 0.305 m

Table E7-72
Head and Sill Track Span

Basic Wind Speed (mph)	Allowable Head and Sill Track Span ^{1,2,3,4} (ft-in.)						
	Exposure		Track Designation				
B	C	350T125-33	350T125-43	350T125-54	550T125-33	550T125-43	550T125-54
115		5'-9"	6'-9"	9'-3"	7'-3"	9'-1"	12'-5"
120		5'-6"	6'-6"	8'-11"	7'-0"	8'-9"	11'-11"
130	115	4'-10"	5'-9"	7'-10"	6'-2"	7'-8"	10'-6"
140	120	4'-8"	5'-6"	7'-6"	5'-11"	7'-4"	10'-1"
150	130	4'-3"	5'-1"	6'-11"	5'-6"	6'-9"	9'-4"
160	140	4'-0"	4'-9"	6'-5"	5'-1"	6'-4"	8'-8"
170	150	3'-8"	4'-5"	6'-0"	4'-9"	5'-11"	8'-1"
188	160	3'-6"	4'-2"	5'-8"	4'-5"	5'-6"	7'-7"
	170	3'-3"	3'-11"	5'-4"	4'-2"	5'-2"	7'-1"
	180	3'-1"	3'-8"	5'-0"	3'-11"	4'-11"	6'-9"

For SI: 1 inch = 25.4 mm, 1 mil = 0.0254 mm, 1 foot = 0.305 m

¹ Deflection Limit: L/240

² Head and sill *track spans* are based on components and cladding wind speeds and 48-inch (1.22-m) tributary *span*.

³ For openings less than 4 feet (1.22 m) in height that have both a head *track* and a sill *track*, the above *spans* are permitted to be multiplied by 1.75. For openings less than or equal to 6 feet (1.83 m) in height that have both a head *track* and a sill *track*, the above *spans* are permitted to be multiplied by a factor of 1.5.

⁴ The minimum *yield strength*, F_y , of *cold-formed steel framing members* is 50 ksi (340 MPa) for members with a *designation thickness* equal to or greater than 54 mils.

Table E8-1
Minimum Percentage of Full-Height
Structural Sheathing on Braced Wall Line

Wall Supporting	Roof Slope	Basic Wind Speed (mph) and Exposure					
		115B	120 B	130 B	<140 B	130 C	<140 C
				115 C	120 C		
Roof & Ceiling Only (One Story or Top Floor of Two- or Three-Story Building)	3:12	9	11	11	13	17	20
	6:12	13	15	17	22	28	35
	9:12	23	27	29	33	53	59
	12:12	32	39	40	44	70	76
One Story, Roof & Ceiling (First Floor of a Two-Story Building or Second Floor of a Three-Story Building)	3:12	26	32	34	39	53	67
	6:12	27	33	34	44	61	75
	9:12	38	45	46	61	78	92
	12:12	43	53	57	72	106	116
Two Story, Roof & Ceiling (First Floor of a Three-Story Building)	3:12	43	53	57	64	89	113
	6:12	41	51	51	67	95	114
	9:12	53	63	63	89	104	126
	12:12	54	67	74	100	142	157

For SI: 1 mph = 0.447 m/sec, 1 inch = 25.4 mm, 1 foot = 0.305 m

¹ Linear interpolation is permitted.

² For hip-roofed homes, the minimum percentage of full-height sheathing, based upon wind, is permitted to be multiplied by a factor of 0.95 for roof slopes not exceeding 7:12 and a factor of 0.9 for roof slopes greater than 7:12.

Table E8-2
Minimum Percentage of Full-Height
Structural Sheathing on Braced Wall Line

Wall Supporting	Seismic Design Category A	Seismic Design Category B	Seismic Design Category C
Roof & Ceiling Only (One Story or Second Floor of Two-Story Building)	6	6	19
One Story, Roof & Ceiling (First Floor of a Two- Story Building)	13	13	40

Table E8-3
Minimum Percentage of Full-Height
Structural Sheathing on Braced Wall Line

Wall Supporting	Seismic Design Category A	Seismic Design Category B	Seismic Design Category C
Roof & Ceiling Only	7	7	22
One Story, Roof & Ceiling	16	16	50
Two Stories, Roof & Ceiling	23	23	70

Table E8-4
Full-Height Sheathing Length Adjustment Factors

Plan Aspect Ratio	Length Adjustment Factors	
	Short Wall	Long Wall
1:1	1.0	1.0
1.5:1	1.5	0.67
2:1	2.0	0.50
3:1	3.0	0.33

Table E8-5
Full-Height Sheathing Length Adjustment Factors

Plan Aspect Ratio	Length Adjustment Factors	
	Short Wall	Long Wall
1:1	1.0	1.0
1.5:1	1.5	1.0
2:1	2.0	1.0
3:1	3.0	1.0

Table E11-1
Full-Height Sheathing Length Adjustment Factors Based Upon Edge Screw Spacing

Bracing Material	Length Adjustment Factors							
	Type I Braced Wall Shearwall Edge Screw Spacing (in.)				Type II Braced Wall Shearwall Edge Screw Spacing (in.)			
	6	4	3	2	6	4	3	2
Wood structural panels	1.00	0.80	0.55	0.50	1.00	0.80	0.80	0.80
Steel sheet panels	NA	0.70	0.65	0.60	NA	0.70	0.70	0.70

For SI: 1inch =25.4 mm

Table E11-2
Type II Braced Wall Full-Height Sheathing Length Adjustment Factors

Percent Fully Sheathed Wall ¹	Length Adjustment Factors					
	Maximum Unrestrained Opening Height					
	H/3	H/2	2H/3	3H/4	5H/6	H
0	1.00	1.50	2.00	2.22	2.50	3.00
20	1.00	1.36	1.67	1.79	1.92	2.14
40	1.00	1.25	1.43	1.49	1.56	1.67
60	1.00	1.15	1.25	1.28	1.32	1.36
80	1.00	1.07	1.11	1.12	1.14	1.15
100	1.00	1.00	1.00	1.00	1.00	1.00

¹ Percent fully sheathed wall is the percent of wall by length, measured between *hold-down* anchors, that is sheathed full-height.

Table E12-1
SDC D₀ Type I Sidewall Sheathing for Top of One- or Two-Story Building
(Normal Roof and Heavy Wall Systems)

Type I Percent Full-Height Sidewall Sheathing ¹						
Aspect Ratio	Diaphragm Span (feet) ²					
	15	20	30	40	50	60
0.25	12	13	17	20	24	28
0.50	12	14	18	21	25	28
0.75	13	15	19	22	26	29
1.00	14	16	20	23	27	30
1.25	-	17	21	24	28	31
1.50	-	-	21	25	29	32
1.75	-	-	22	26	29	33
2.00	-	-	23	27	30	34
2.25	-	-	-	28	31	35
2.50	-	-	-	29	32	36
2.75	-	-	-	30	33	37
3.00	-	-	-	-	34	38
3.25	-	-	-	-	35	38
3.50	-	-	-	-	-	39
3.75	-	-	-	-	-	40
4.00	-	-	-	-	-	41

¹ Interpolation is permitted for intermediate values of diaphragm span and aspect ratio.

² Diaphragm span is the dimension of the diaphragm perpendicular to the walls under consideration.

Table E12-2
SDC D₀ Type I Sidewall Sheathing for Bottom of Two-Story Building
(Normal Roof and Heavy Wall Systems)

Type I Percent Full-Height Sidewall Sheathing ¹						
Aspect Ratio	Diaphragm Span (feet) ²					
	15	20	30	40	50	60
0.25	16	18	23	28	33	38
0.50	18	20	25	30	35	39
0.75	19	22	27	31	36	41
1.00	21	24	28	33	38	43
1.25	-	25	30	35	40	44
1.50	-	-	32	37	41	46
1.75	-	-	33	38	43	48
2.00	-	-	35	40	45	49
2.25	-	-	-	42	46	51
2.50	-	-	-	43	48	53
2.75	-	-	-	45	50	55
3.00	-	-	-	-	51	56
3.25	-	-	-	-	53	58
3.50	-	-	-	-	-	60
3.75	-	-	-	-	-	61
4.00	-	-	-	-	-	63

¹ Interpolation is permitted for intermediate values of *diaphragm span* and aspect ratio.

² *Diaphragm span* is the dimension of the *diaphragm* perpendicular to the walls under consideration.

Table E12-3
SDC D₀ Type I Sidewall Sheathing for Top of Three-Story Building
(Normal Roof and Heavy Wall Systems)

Type I Percent Full-Height Sidewall Sheathing ¹						
Aspect Ratio	Diaphragm Span (feet) ²					
	15	20	30	40	50	60
0.25	13	15	19	24	28	32
0.50	14	16	20	25	29	33
0.75	15	17	22	26	30	34
1.00	16	18	23	27	31	35
1.25	-	20	24	28	32	36
1.50	-	-	25	29	33	37
1.75	-	-	26	30	34	38
2.00	-	-	27	31	35	39
2.25	-	-	-	32	36	40
2.50	-	-	-	33	37	41
2.75	-	-	-	34	38	42
3.00	-	-	-	-	39	43
3.25	-	-	-	-	40	44
3.50	-	-	-	-	-	45
3.75	-	-	-	-	-	46
4.00	-	-	-	-	-	47

¹ Interpolation is permitted for intermediate values of *diaphragm span* and aspect ratio.

² *Diaphragm span* is the dimension of the *diaphragm* perpendicular to the walls under consideration.

Table E12-4
SDC D₀ Type I Sidewall Sheathing for Middle of Three-Story Building
(Normal Roof and Heavy Wall Systems)

Type I Percent Full-Height Sidewall Sheathing ¹						
Aspect Ratio	Diaphragm Span (feet) ²					
	15	20	30	40	50	60
0.25	20	23	29	35	41	47
0.50	22	25	31	37	43	49
0.75	24	27	33	39	45	51
1.00	26	29	35	41	47	53
1.25	-	32	38	44	50	55
1.50	-	-	40	46	52	58
1.75	-	-	42	48	54	60
2.00	-	-	44	50	56	62
2.25	-	-	-	52	58	64
2.50	-	-	-	54	60	66
2.75	-	-	-	56	62	68
3.00	-	-	-	-	64	70
3.25	-	-	-	-	66	72
3.50	-	-	-	-	-	75
3.75	-	-	-	-	-	77
4.00	-	-	-	-	-	79

¹ Interpolation is permitted for intermediate values of *diaphragm span* and aspect ratio.

² *Diaphragm span* is the dimension of the *diaphragm* perpendicular to the walls under consideration.

Table E12-5
SDC D₀ Type I Sidewall Sheathing for Bottom of Three-Story Building
(Normal Roof and Heavy Wall Systems)

Type I Percent Full-Height Sidewall Sheathing ¹						
Aspect Ratio	Diaphragm Span (feet) ²					
	15	20	30	40	50	60
0.25	24	27	34	41	48	55
0.50	27	30	37	44	51	58
0.75	29	33	40	47	54	61
1.00	32	36	43	50	56	63
1.25	-	39	45	52	59	66
1.50	-	-	48	55	62	69
1.75	-	-	51	58	65	72
2.00	-	-	54	61	68	75
2.25	-	-	-	64	71	78
2.50	-	-	-	67	74	81
2.75	-	-	-	70	76	83
3.00	-	-	-	-	79	86
3.25	-	-	-	-	82	89
3.50	-	-	-	-	-	92
3.75	-	-	-	-	-	95
4.00	-	-	-	-	-	98

¹ Interpolation is permitted for intermediate values of diaphragm span and aspect ratio.

² *Diaphragm span* is the dimension of the *diaphragm* perpendicular to the walls under consideration.

Table E12-6
SDC D₁ Type I Sidewall Sheathing for Top of One- or Two-Story Building
(Normal Roof and Heavy Wall Systems)

Type I Percent Full-Height Sidewall Sheathing ¹						
Aspect Ratio	Diaphragm Span (feet) ²					
	15	20	30	40	50	60
0.25	14	17	21	25	30	34
0.50	15	18	22	26	31	35
0.75	17	19	23	28	32	36
1.00	18	20	24	29	33	38
1.25	-	21	25	30	34	39
1.50	-	-	27	31	35	40
1.75	-	-	28	32	36	41
2.00	-	-	29	33	38	42
2.25	-	-	-	34	39	43
2.50	-	-	-	35	40	44
2.75	-	-	-	37	41	45
3.00	-	-	-	-	42	47
3.25	-	-	-	-	43	48
3.50	-	-	-	-	-	49
3.75	-	-	-	-	-	50
4.00	-	-	-	-	-	51

¹ Interpolation is permitted for intermediate values of *diaphragm span* and aspect ratio.

² *Diaphragm span* is the dimension of the *diaphragm* perpendicular to the walls under consideration.

Table E12-7
SDC D₁ Type I Sidewall Sheathing for Bottom of Two-Story Building
(Normal Roof and Heavy Wall Systems)

Type I Percent Full-Height Sidewall Sheathing ¹						
Aspect Ratio	Diaphragm Span (feet) ²					
	15	20	30	40	50	60
0.25	20	23	29	35	41	47
0.50	22	25	31	37	43	49
0.75	24	27	33	39	45	51
1.00	26	29	35	41	47	53
1.25	-	31	37	43	49	55
1.50	-	-	39	45	51	57
1.75	-	-	41	47	53	59
2.00	-	-	44	49	55	61
2.25	-	-	-	52	57	63
2.50	-	-	-	54	60	66
2.75	-	-	-	56	62	68
3.00	-	-	-	-	64	70
3.25	-	-	-	-	66	72
3.50	-	-	-	-	-	74
3.75	-	-	-	-	-	76
4.00	-	-	-	-	-	78

¹ Interpolation is permitted for intermediate values of *diaphragm span* and aspect ratio.

² *Diaphragm span* is the dimension of the *diaphragm* perpendicular to the walls under consideration.

Table E12-8
SDC D₁ Type I Sidewall Sheathing for Top of Three-Story Building
(Normal Roof and Heavy Wall Systems)

Type I Percent Full-Height Sidewall Sheathing ¹						
Aspect Ratio	Diaphragm Span (feet) ²					
	15	20	30	40	50	60
0.25	16	19	24	29	34	39
0.50	18	20	25	30	35	41
0.75	19	22	27	32	37	42
1.00	20	23	28	33	38	43
1.25	-	24	29	34	39	44
1.50	-	-	31	36	41	46
1.75	-	-	32	37	42	47
2.00	-	-	33	38	43	48
2.25	-	-	-	39	45	50
2.50	-	-	-	41	46	51
2.75	-	-	-	42	47	52
3.00	-	-	-	-	48	53
3.25	-	-	-	-	50	55
3.50	-	-	-	-	-	56
3.75	-	-	-	-	-	57
4.00	-	-	-	-	-	59

¹ Interpolation is permitted for intermediate values of *diaphragm span* and aspect ratio.

² *Diaphragm span* is the dimension of the *diaphragm* perpendicular to the walls under consideration.

Table E12-9
SDC D₁ Type I Sidewall Sheathing for Middle of Three-Story Building
(Normal Roof and Heavy Wall Systems)

Type I Percent Full-Height Sidewall Sheathing ¹						
Aspect Ratio	Diaphragm Span (feet) ²					
	15	20	30	40	50	60
0.25	25	29	36	43	51	58
0.50	28	31	39	46	53	61
0.75	30	34	41	49	56	64
1.00	33	36	44	51	59	66
1.25	-	39	47	54	61	69
1.50	-	-	49	57	64	71
1.75	-	-	52	59	67	74
2.00	-	-	54	62	69	77
2.25	-	-	-	64	72	79
2.50	-	-	-	67	74	82
2.75	-	-	-	70	77	85
3.00	-	-	-	-	80	87
3.25	-	-	-	-	82	90
3.50	-	-	-	-	-	92
3.75	-	-	-	-	-	95
4.00	-	-	-	-	-	98

¹ Interpolation is permitted for intermediate values of *diaphragm span* and aspect ratio.

² *Diaphragm span* is the dimension of the *diaphragm* perpendicular to the walls under consideration.

Table E12-10
SDC D₁ Type I Sidewall Sheathing for Bottom of Three-Story Building
(Normal Roof and Heavy Wall Systems)

Type I Percent Full-Height Sidewall Sheathing ¹						
Aspect Ratio	Diaphragm Span (feet) ²					
	15	20	30	40	50	60
0.25	29	34	42	51	59	68
0.50	33	37	46	54	63	71
0.75	36	41	49	58	66	75
1.00	40	44	53	61	70	79
1.25	-	48	56	65	73	82
1.50	-	-	60	68	77	86
1.75	-	-	63	72	81	89
2.00	-	-	67	76	84	93
2.25	-	-	-	79	88	96
2.50	-	-	-	83	91	100
2.75	-	-	-	86	95	103
3.00	-	-	-	-	98	107
3.25	-	-	-	-	102	110
3.50	-	-	-	-	-	114
3.75	-	-	-	-	-	117
4.00	-	-	-	-	-	121

¹ Interpolation is permitted for intermediate values of *diaphragm span* and aspect ratio.

² *Diaphragm span* is the dimension of the *diaphragm* perpendicular to the walls under consideration.

Table E12-11
SDC D₂ Type I Sidewall Sheathing for Top of One- or Two-Story Building
(Normal Roof and Heavy Wall Systems)

Type I Percent Full-Height Sidewall Sheathing ¹						
Aspect Ratio	Diaphragm Span (feet) ²					
	15	20	30	40	50	60
0.25	22	25	32	38	45	51
0.50	23	27	33	40	46	53
0.75	25	28	35	42	48	55
1.00	27	30	37	43	50	56
1.25	-	32	38	45	52	58
1.50	-	-	40	47	53	60
1.75	-	-	42	48	55	62
2.00	-	-	43	50	57	63
2.25	-	-	-	52	58	65
2.50	-	-	-	53	60	67
2.75	-	-	-	55	62	68
3.00	-	-	-	-	63	70
3.25	-	-	-	-	65	72
3.50	-	-	-	-	-	73
3.75	-	-	-	-	-	75
4.00	-	-	-	-	-	77

¹ Interpolation is permitted for intermediate values of *diaphragm span* and aspect ratio.

² *Diaphragm span* is the dimension of the *diaphragm* perpendicular to the walls under consideration.

Table E12-12
SDC D₂ Type I Sidewall Sheathing for Bottom of Two-Story Building
(Normal Roof and Heavy Wall Systems)

Type I Percent Full-Height Sidewall Sheathing ¹						
Aspect Ratio	Diaphragm Span (feet) ²					
	15	20	30	40	50	60
0.25	30	34	43	52	61	70
0.50	33	38	47	55	64	73
0.75	36	41	50	59	68	77
1.00	39	44	53	62	71	80
1.25	-	47	56	65	74	83
1.50	-	-	59	68	77	86
1.75	-	-	62	71	80	89
2.00	-	-	66	74	83	92
2.25	-	-	-	78	87	95
2.50	-	-	-	81	90	99
2.75	-	-	-	84	93	102
3.00	-	-	-	-	96	105
3.25	-	-	-	-	99	108
3.50	-	-	-	-	-	111
3.75	-	-	-	-	-	114
4.00	-	-	-	-	-	118

¹ Interpolation is permitted for intermediate values of *diaphragm span* and aspect ratio.

² *Diaphragm span* is the dimension of the *diaphragm* perpendicular to the walls under consideration.

Table E12-13
SDC D₂ Type I Sidewall Sheathing for Top of Three-Story Building
(Normal Roof and Heavy Wall Systems)

Type I Percent Full-Height Sidewall Sheathing ¹						
Aspect Ratio	Diaphragm Span (feet) ²					
	15	20	30	40	50	60
0.25	25	29	36	44	51	59
0.50	27	31	38	46	53	61
0.75	29	33	40	48	55	63
1.00	31	34	42	50	57	65
1.25	-	36	44	52	59	67
1.50	-	-	46	54	61	69
1.75	-	-	48	56	63	71
2.00	-	-	50	58	65	73
2.25	-	-	-	59	67	75
2.50	-	-	-	61	69	77
2.75	-	-	-	63	71	79
3.00	-	-	-	-	73	81
3.25	-	-	-	-	75	82
3.50	-	-	-	-	-	84
3.75	-	-	-	-	-	86
4.00	-	-	-	-	-	88

¹ Interpolation is permitted for intermediate values of *diaphragm span* and aspect ratio.

² *Diaphragm span* is the dimension of the *diaphragm* perpendicular to the walls under consideration.

Table E12-14
SDC D₂ Type I Sidewall Sheathing for Middle of Three-Story Building
(Normal Roof and Heavy Wall Systems)

Type I Percent Full-Height Sidewall Sheathing ¹						
Aspect Ratio	Diaphragm Span (feet) ²					
	15	20	30	40	50	60
0.25	37	43	54	65	77	88
0.50	41	47	58	69	81	92
0.75	45	51	62	73	84	96
1.00	49	55	66	77	88	100
1.25	-	59	70	81	92	104
1.50	-	-	74	85	96	107
1.75	-	-	78	89	100	111
2.00	-	-	82	93	104	115
2.25	-	-	-	97	108	119
2.50	-	-	-	101	112	123
2.75	-	-	-	105	116	127
3.00	-	-	-	-	120	131
3.25	-	-	-	-	124	135
3.50	-	-	-	-	-	139
3.75	-	-	-	-	-	143
4.00	-	-	-	-	-	147

¹ Interpolation is permitted for intermediate values of *diaphragm span* and aspect ratio.

² *Diaphragm span* is the dimension of the *diaphragm* perpendicular to the walls under consideration.

Table E12-15
SDC D₂ Type I Sidewall Sheathing for Bottom of Three-Story Building
(Normal Roof and Heavy Wall Systems)

Type I Percent Full-Height Sidewall Sheathing ¹						
Aspect Ratio	Diaphragm Span (feet) ²					
	15	20	30	40	50	60
0.25	44	51	64	76	89	102
0.50	49	56	69	82	95	108
0.75	55	61	74	87	100	113
1.00	60	67	79	92	105	118
1.25	-	72	85	98	111	124
1.50	-	-	90	103	116	129
1.75	-	-	95	108	121	134
2.00	-	-	101	114	127	140
2.25	-	-	-	119	132	145
2.50	-	-	-	124	137	150
2.75	-	-	-	130	143	156
3.00	-	-	-	-	148	161
3.25	-	-	-	-	153	166
3.50	-	-	-	-	-	172
3.75	-	-	-	-	-	177
4.00	-	-	-	-	-	182

¹ Interpolation is permitted for intermediate values of *diaphragm span* and aspect ratio.

² *Diaphragm span* is the dimension of the *diaphragm* perpendicular to the walls under consideration.

Table E12-16
Braced Wall Full-Height Sheathing Length Adjustment Factors
for Roof and Exterior Wall System Weights ¹

Braced Wall Supporting	Lightweight Roof/Ceiling Assembly	Lightweight Exterior Walls	Buildings Having Both lightweight Walls and Roofs	Lightweight Exterior Walls and Heavy Roof/Ceiling Assembly	Heavyweight Roof/Ceiling Assembly
Roof/Ceiling Only	0.91	0.90	0.78	1.25	1.35
One Floor and Roof/Ceiling	0.95	0.86	0.78	1.10	1.25

For SI: 1 psf = 0.0479 kN/m²

¹ Factors are based on the baseline configuration of a *normal weight roof* and a *heavyweight exterior wall*. See Table A1-1 for roof and wall system weights.

Table E12-17
Required Hold-Down Anchor¹ and Chord Stud Strengths - Seismic

Required Hold-Down Anchor and Chord Stud Strengths (lbs)				
Wall Height (ft)	Panel Edge Screw Spacing (in.)			
	6	4	3	2
8	2250	2950	4120	5260
9	2530	3310	4620	5900
10	2800	3670	5120	6540

For SI: 1 inch = 25.4 mm, 1 foot = 0.305 m, 1 lb = 4.45 N

¹ Required strengths are nominal values to be used with published strengths expressed as allowable loads.

Table E12-18
Required Shear Anchorage for Braced Walls

Required Anchor Bolt Spacing (ft-in.)				
Anchor Bolt Diameter (in.)	Panel Edge Screw Spacing (in.)			
	6	4	3	2
1/2"	5'-0"	3'-6"	2'-6"	2'-0"
5/8"	6'-0"	4'-6"	3'-3"	2'-6"

For SI: 1 inch = 25.4 mm, 1 foot = 0.305 m

Table E12-19
Allowable Chord Stud Strength ^{1,2}

Chord Stud Strength (lbs)			
(2) Back-to-Back	Wall Height (ft)		
	8	9	10
350S162 -33	5420	5160	4860
350S162 -43	7380	7000	6590
550S162 -33	5550	5930	5810
550S162 -43	7670	8300	8110

For SI: 1 inch = 25.4 mm, 1 foot = 0.305 m, 1 lb = 4.45 N

¹ *Chord stud* strengths given are for (2) back-to-back *studs* connected with a minimum of (2) No. 8 screws at 12 inches on center vertically.

² *Chord stud* strengths are nominal values based on Allowable Strength Design with bracing provided according to Section E4.

Table E12-20
Top Track Thickness and Splice Screw Requirements ^{1,2,3}

Total Number of No. 8 Screws on Each Side of Track Splice																				
Diaph. Span	Aspect Ratio		Seismic Design Category																	
			D ₀						D ₁						D ₂					
			NR/ HW	LR/ HW	NR/ LW	LR/ LW	HR/ LW	HR/ HW	NR/ HW	LR/ HW	NR/ LW	LR/ LW	HR/ LW	HR/ HW	NR/ HW	LR/ HW	NR/ LW	LR/ LW	HR/ LW	HR/ HW
60'	≥3	Roof	23	20	19	16	18	20	28	25	23	20	22	25	43	37	35	30	34	NA ³
		1st	17	17	12	12	12	17	21	21	15	15	15	21	32	32	22	22	22	NA ³
	<3	Roof	19	17	16	15	15	18	23	21	20	18	19	22	35	32	30	28	28	34
		1st	14	14	11	11	11	14	17	17	13	13	13	17	26	26	21	21	21	26
50'	≥ 2.5	Roof	16	14	13	11	19	15	20	17	16	14	23	18	30	26	24	21	35	28
		1st	12	12	9	9	9	12	15	15	11	11	11	15	22	22	17	17	17	22
	<2.5	Roof	13	11	11	10	16	12	16	14	14	12	20	15	24	21	21	19	30	22
		1st	9	9	7	7	7	9	11	11	9	9	9	11	17	17	13	13	13	17
40'	≥2.67	Roof	11	9	8	7	12	14	13	11	10	9	15	17	21	17	15	13	22	26
		1st	7	7	6	6	6	7	9	9	7	7	7	9	14	14	11	11	11	13
	<2.67	Roof	9	8	8	6	11	12	11	10	10	8	14	15	17	17	15	12	21	22
		1st	6	6	5	5	5	6	8	8	6	6	6	8	11	12	9	9	9	11
30'	All	Roof	6	5	5	4	6	8	7	6	6	5	8	10	11	9	9	7	12	15
		1st	4	4	3	3	3	4	5	5	4	4	4	5	8	8	6	6	6	8
<20'	All	Roof	2	2	2	2	3	4	3	3	3	2	4	5	5	4	4	4	6	7
		1st	2	2	2	2	2	2	2	2	2	2	2	2	4	3	4	4	4	4

For SI: 1 inch = 25.4 mm, 1 foot = 0.305 m

¹ Minimum top track thickness is 33 mil (0.84 mm), except where indicated by shading. In locations indicated by shading, minimum top track thickness is 43 mils (1.09 mm).

² NR = Normal Weight Roof; LR = Lightweight Roof; HR = Heavyweight Roof

³ HW = Heavyweight Exterior Wall; LW = Lightweight Exterior Wall

Table E13-1
Range of Allowable Sidewall Lengths
(One-Story Slab on Grade)

		Basic Wind Speed (mph)									
EXPOSURE B		160		170		180					
EXPOSURE C		140		150		160		170		180	
Foundation Supporting	Building Endwall Width (ft)	Allowable Building Sidewall Length (ft)									
		Min	Max	Min	Max	Min	Max	Min	Max	Min	Max
One-Story Slab on Grade	12	10	38	10	32	10	27	10	22	10	19
	16	10	51	10	42	10	35	10	30	11	26
	20	10	64	10	52	10	44	12	37	12	33
	24	10	75	10	62	12	53	13	44	15	38
	28	10	80	12	73	14	62	15	52	18	45
	32	11	80	14	80	16	71	18	60	20	51
	36	13	80	15	80	18	80	20	67	23	58
	40	14	80	17	80	20	80	22	74	26	64

For SI: 1 foot = 0.305 m, 1 mph = 1.61 km/hr

Table E13-2
Range of Allowable Sidewall Lengths
(All Other Cases)

		Basic Wind Speed (mph)									
EXPOSURE B		160		170		180					
EXPOSURE C		140		150		160		170		180	
Foundation Supporting	Building Endwall Width (ft)	Allowable Building Sidewall Length (ft)									
		Min	Max	Min	Max	Min	Max	Min	Max	Min	Max
1-3 Stories	12	10	27	10	22	10	19	10	15	10	13
	16	10	36	10	30	10	25	11	21	11	18
	20	10	45	10	37	11	31	13	26	14	23
	24	10	54	12	45	14	37	15	32	17	28
	28	11	63	14	51	16	44	17	36	20	32
	32	13	72	15	59	18	50	20	42	23	36
	36	15	80	17	66	20	56	23	47	26	41
	40	16	80	19	74	23	63	25	53	29	46

For SI: 1 foot = 0.305 m, 1 mph = 1.61 km/hr

Table E13-3
Type I Braced Wall Panel
Sidewall Sheathing Length Requirements

		Basic Wind Speed (mph)				
EXPOSURE B		160	170	180		
EXPOSURE C		140	150	160	170	180
Braced Wall Supporting	Building Endwall Length, W (ft)	Minimum Length of Full-Height Sheathing on Building Sidewall, L ^{1,2,3} (ft)				
Roof/Ceiling Only ⁴	12	5	5	5	5	5
	16	5	5	5	5	6
	20	5	5	6	7	7
	24	5	6	7	8	9
	28	6	7	8	9	10
	32	6	8	9	10	12
	36	7	9	10	12	12
	40	8	10	11	13	14
One Floor and Roof/Ceiling ⁵	20	8	10	11	13	14
	24	10	12	14	15	17
	28	11	14	16	17	20
	32	13	15	18	20	23
	36	15	17	20	23	26
	40	16	19	23	25	29
Two Floors and Roof/Ceiling ⁶	20	12	15	17	19	22
	24	15	17	20	23	26
	28	17	20	24	27	31
	32	20	23	26	31	34
	36	22	26	30	35	39
	40	24	29	33	38	43

For SI: 1 foot = 0.305 m, 1 mph = 1.61 km/hr

¹ Tabulated sheathing lengths are based on 8-foot (2.44-m) wall heights. For 9-foot (2.74-m) wall heights the tabulated values are to be multiplied by 1.13. For 10-foot (3.05 m) wall heights, the tabulated values are to be multiplied by 1.25.

² Tabulated sheathing lengths assume a *mean roof height* of 33 feet (10.8 m). For *mean roof heights* of 15 feet (4.92 m) or less, the tabulated values are permitted to be multiplied by 0.8.

³ Tabulated sheathing lengths assume a 6-inch (152-mm) edge screw spacing. Required lengths are permitted to be multiplied by the adjustment factors in Table E11-1 for edge screw spacing other than 6 inches (152 mm), but the resulting sheathing length shall not be less than 5 feet (1.64 m).

⁴ Applies to a one story building or the top story of a two or three story building.

⁵ Applies to the lower story of a two-story building and the middle story of a three story building.

⁶ Applies to the lower story of a three-story building.

Table E13-4
Type I Braced Wall Panel
Endwall Sheathing Length Requirements

		Basic Wind Speed (mph)				
EXPOSURE B		160	170	180		
EXPOSURE C		140	150	160	170	180
Braced Wall Supporting	Building Sidewall Length, W (ft)	Minimum Length of Full-Height Sheathing on Building Endwall, L ^{1,2,3} (ft)				
Roof/Ceiling Only ⁴	12	5	5	5	5	5
	16	5	5	5	5	5
	20	5	5	5	6	7
	24	5	5	6	7	8
	28	5	6	7	8	9
	32	6	7	8	9	11
	36	6	8	9	10	12
	40	7	9	10	12	12
	50	9	11	12	14	16
One Floor and Roof/Ceiling ⁵	20	9	11	13	15	16
	24	11	13	15	16	19
	28	13	15	18	19	22
	32	14	17	20	22	26
	36	16	19	23	25	29
	40	18	21	25	28	31
	50	22	27	30	35	41
	60	27	32	37	42	48
Two Floors and Roof/Ceiling ⁶	20	15	18	21	23	26
	24	18	21	25	28	31
	28	21	25	28	32	36
	32	24	28	32	36	42
	36	27	32	36	41	47
	40	30	35	40	46	52
	50	37	44	51	58	66
	60	44	53	61	69	78

For SI: 1 foot = 0.305 m, 1 mph = 1.61 km/hr

¹ Tabulated sheathing lengths are based on 8-foot (2.44 m) wall heights. For 9-foot (2.74 m) wall heights the tabulated values are to be multiplied by 1.13. For 10-foot (3.05 m) wall heights, the tabulated values are to be multiplied by 1.25.

² Tabulated sheathing lengths are based on a *mean roof height* of 33 (10.8 m) feet. For *mean roof heights* of 15 feet (4.92 m) or less, the tabulated values are permitted to be multiplied by 0.8.

³ Tabulated sheathing lengths are based on a 6-inch (152 mm) edge screw spacing. Required lengths are permitted to be multiplied by the adjustment factors in Table E11-1 for edge screw spacing other than 6 inches (152 mm), but the resulting sheathing length shall not be less than 5 feet (1.64 m).

⁴ Applies to a one-story building or the top story of a two-story building.

⁵ Applies to the lower story of a two-story building and the middle story of a three-story building.

⁶ Applies to the lower story of a three-story building.

**Table E13-5
Required Uplift Strength
Wall Assembly to Wall Assembly**

		Basic Wind Speed (mph)				
EXPOSURE B		160	170	180		
EXPOSURE C		140	150	160	170	180
Framing Spacing ³ (in.)	Roof Span (ft)	Required Connection Strength ^{1,2} (lbs)				
12	24	222	275	333	394	459
	28	254	315	380	449	523
	32	287	355	427	504	586
	36	319	394	474	559	650
	40	352	434	521	614	713
16	24	295	367	444	526	613
	28	339	420	507	599	697
	32	382	473	569	672	781
	36	426	526	632	746	866
	40	470	579	695	819	951
19.2	24	354	441	533	631	735
	28	406	504	608	719	836
	32	459	567	683	807	938
	36	511	631	759	895	1040
	40	564	694	834	983	1140
24	24	443	551	666	789	919
	28	508	630	760	898	1050
	32	573	709	854	1010	1170
	36	639	788	948	1120	1300
	40	704	868	1040	1230	1430

For SI: 1 inch = 25.4 mm, 1 foot = 0.305 m, 1 lb = 4.45 N, 1 mph = 1.61 km/hr

¹ Uplift requirements assume a roof/ceiling dead load of 12 psf (0.58 kN/m²).

² Required connection strengths are nominal values to be used with published strengths expressed as allowable loads.

³ The 12-inch (305-mm) and 19.2-inch (488 mm) framing spacing provide options for design, but do not negate the *in-line framing* requirement of Chapter E.

Table E13-6
Uplift Strap Connection Requirements
Wall Assembly to Wall Assembly

		Basic Wind Speed (mph)				
EXPOSURE B		130	140	150		
EXPOSURE C		110	120	130	140	140
Framing Spacing ¹ (in.)	Roof Span (ft)	Number of No. 8 Screws in Each End of Steel Uplift Strap				
12	24	2	2	3	3	3
	28	2	2	3	3	4
	32	2	3	3	4	4
	36	2	3	3	4	4
	40	3	3	4	4	5
16	24	2	3	3	4	4
	28	3	3	4	4	5
	32	3	3	4	5	5
	36	3	4	4	5	6
	40	3	4	5	5	6
19.2	24	3	3	4	4	5
	28	3	4	4	5	6
	32	3	4	5	5	6
	36	4	4	5	6	7
	40	4	5	6	6	7
24	24	3	4	5	5	6
	28	4	4	5	6	7
	32	4	5	6	7	8
	36	4	5	6	7	8
	40	5	6	7	8	9

For SI: 1 inch = 25.4 mm, 1 foot = 0.305 m, 1 mph = 1.61 km/hr

¹ The 12-inch (305-mm) and 19.2-inch (488-mm) framing spacing provide options for design, but do not negate the *in-line framing* requirement of Chapter E.

Table E13-7
Required Uplift Strength
Roof Rafter or Roof Truss to Wall

		Basic Wind Speed (mph)				
EXPOSURE B		160	170	180		
EXPOSURE C		140	150	160	170	180
Framing Spacing ³ (in.)	Roof Span (ft)	Required Connection Strength ^{1,2} (lbs)				
12	24	270	323	381	442	507
	28	302	363	428	497	571
	32	335	403	475	552	634
	36	367	442	522	607	698
	40	400	482	569	662	761
16	24	359	431	508	590	677
	28	403	484	571	663	761
	32	446	537	633	736	845
	36	490	590	696	810	930
	40	534	643	759	883	1020
19.2	24	431	517	610	708	812
	28	483	581	685	796	913
	32	536	644	760	883	1010
	36	588	708	835	972	1120
	40	640	771	911	1060	1220
24	24	539	647	762	885	1020
	28	604	726	856	994	1140
	32	669	805	950	1100	1270
	36	735	884	1040	1220	1400
	40	800	964	1140	1330	1520

For SI: 1 inch = 25.4 mm, 1 foot = 0.305 m, 1 lb = 4.45 N, 1 mph = 1.61 km/hr

¹ Uplift requirements assume a roof/ceiling dead load of 12 psf (0.58 kN/m²).

² Required connection strengths are nominal values to be used with published strengths expressed as allowable loads.

³ The 12-inch (305-mm) and 19.2-inch (488-mm) framing spacing provide options for design, but do not negate the in-line framing requirement of Chapter E.

Table E13-8
Uplift Strap Connection Requirements
Roof Rafter or Roof Truss to Wall

		Basic Wind Speed (mph)				
Exposure B		160	170	180		
Exposure C		140	150	160	170	180
Framing Spacing ¹ (in.)	Roof Span (ft)	Number of No. 8 Screws in Each End of Steel Uplift Strap				
12	24	2	2	3	3	4
	28	2	3	3	4	4
	32	3	3	3	4	4
	36	3	3	4	4	5
	40	3	3	4	5	5
16	24	3	3	4	4	5
	28	3	3	4	5	5
	32	3	4	4	5	6
	36	3	4	5	5	6
	40	4	4	5	6	7
19.2	24	3	4	4	5	5
	28	3	4	5	5	6
	32	4	4	5	6	7
	36	4	5	6	6	7
	40	4	5	6	7	8
24	24	4	4	5	6	7
	28	4	5	6	7	7
	32	5	5	6	7	8
	36	5	6	7	8	9
	40	5	6	7	9	10

For SI: 1 inch = 25.4 mm, 1 foot = 0.305 m, 1 mph = 1.61 km/hr

¹ The 12-inch (305-mm) and 19.2-inch (488-mm) framing spacing provide options for design, but do not negate the *in-line framing* requirement of Chapter E.

Table E13-9
Minimum Size of Steel Uplift Strap

Strap Width (in.)	Minimum Thickness of Strap (mils) ²									
	Required Number of Screws ¹									
	4 OR LESS	5	6	7	8	9	10	11	12	13
1.25	33	43	54	54	68	68	97	97	97	97
1.50	33	43	43	54	54	68	68	97	97	97
1.75	33	33	33	43	54	54	54	68	68	97
2.00	33	33	33	43	43	54	54	68	68	68

For SI: 1 inch = 25.4 mm, 1 mil = 0.0254 mm

¹ Required number of screws per Table E13-6 or E13-8 in each end of the steel uplift strap.

² The minimum yield strength, F_y , of cold-formed steel framing members is 50 ksi (340 MPa) for members with a designation thickness equal to or greater than 54 mils.

Table E13-10
Required Hold-Down Anchor¹ and Chord Stud Strengths - Wind

Required Hold-Down Anchor and Chord Stud Strengths (lbs) ²				
Wall Height (ft)	Panel Edge Screw Spacing (in.)			
	6	4	3	2
8	3030	3972	5548	7082
9	3400	4457	6222	7938
10	3770	4938	6895	8798

For SI: 1 inch = 25.4 mm, 1 foot = 0.305 m, 1 lb = 4.45 N

¹ Required strengths are nominal values to be used with published strengths expressed as allowable loads.

² Required strengths are permitted to be multiplied by a factor equal to the required full-height sheathing length divided by the actual full-height sheathing length that is provided.

F. ROOF FRAMING

F1 Roof Construction

Roof framing shall consist of *ceiling joists*, *roof rafters*, and other structural elements as required by Sections F2 to F5, as applicable. Alternatively, *roof trusses* are permitted subject to the requirements in Section F6.

F2 Ceiling Joists

F2.1 Minimum Ceiling Joist Size

Ceiling joist size and thickness shall be determined in accordance with the limits set forth in Tables F2-1 through F2-2. When determining the size of *ceiling joists*, the lateral support of the top *flange* shall be classified as unbraced, braced at mid-*span*, or braced at third points in accordance with Section F2.4. Where sheathing material is attached to the top *flange* of *ceiling joists* or where the *bracing* is spaced closer than third point of the *joists*, the "third point" values from Tables F2-1 through F2-2 shall be used.

When continuous *joists* are framed across interior bearing supports, the interior bearing supports shall be located within 2 feet (0.610 m) of the mid-point along the length of the *ceiling joist*, and the individual *spans* shall not exceed the applicable *spans* in Tables F2-1 through F2-2. **Exception:** Tables F2-1 and F2-2 are not applicable for 350S162-33, 350S162-43, 550S162-33, 550S162-43 and 800S162-43 continuous *joist* members.

Ceiling joists shall have a bearing support length of not less than 1.5 inches (38 mm) and shall be connected to *roof rafters* (heel joint) with No. 10 screws in accordance with Figures F2-1, F2-2 and F2-3 and Table F2-3.

When the attic is to be used as an occupied space, the *ceiling joists* shall be designed in accordance with Section D.

F2.2 Ceiling Joist Bearing Stiffeners

Bearing stiffeners are permitted to be installed at each bearing support in accordance with Section B2 and Figure F2-3.

F2.3 Ceiling Joist Bottom Flange Bracing

The bottom *flanges* of *ceiling joists* shall be laterally braced by the application of gypsum board or continuous steel *straps* installed perpendicular to the *joist* run, in accordance with one of the following:

- (a) Gypsum board shall be fastened with No. 6 screws in accordance with Table F2-4.
- (b) Steel straps with a minimum size of 1-1/2 inch x 33 mil (38 mm x 0.84 mm) shall be installed at a maximum spacing of 4 feet (1.2 m). *Straps* shall be fastened to the bottom *flange* at each *joist* with one No. 8 screw and shall be fastened to *blocking* with two No. 8 screws. *Blocking* shall be installed between *joists* at a maximum spacing of 12 feet (3.7 m) measured along a line of continuous strapping (perpendicular to the *joist* run). *Blocking* shall also be located at the termination of all straps.

F2.4 Ceiling Joist Top Flange Bracing

The top *flanges* of *ceiling joists* shall be laterally braced as required by Tables F2-1 through F2-2, in accordance with one of the following:

- (a) Minimum 33 mil (0.84 mm) *C-shaped* member in accordance with Figure F2-5.
- (b) Minimum 33 mil (0.84 mm) *track* section in accordance with Figure F2-5.

- (c) Minimum 33 mil (0.84 mm) hat section in accordance with Figure F2-5.
- (d) Minimum 54 mil (1.37 mm) 1-1/2 inch cold-rolled channel section in accordance with Figure F2-5.
- (e) Minimum 1-1/2 inch x 33 mil (38 mm x 0.84 mm) continuous steel *strap* in accordance with Figure F2-6.

Lateral *bracing* shall be installed perpendicular to the *ceiling joists* and shall be fastened to the top *flange* of each *joist* with one No. 8 screw. *Blocking* shall be installed between *joists* in-line with *bracing* at a maximum spacing of 12 feet (3.66 m) measured perpendicular to the *joists*. Ends of lateral *bracing* shall be attached to *blocking* or anchored to a stable building component with two No. 8 screws.

Exception: When *strap bracing* and 3.5 inch (88.9 mm) *ceiling joists* are used, *strap bracing* shall be fastened to *blocking* with three No. 8 screws and ends of the *strap bracing* shall be attached to *blocking* or anchored to a stable building component with three No. 8 screws.

F2.5 Ceiling Joist Splicing

Splices in *ceiling joists* are permitted, provided that *ceiling joist* splices are supported at interior bearing points and are constructed in accordance with Figure F2-4. The number of screws on each side of the splice shall be the same as required for the heel joint connection in Table F2-3.

F3 Roof Rafters

F3.1 Minimum Roof Rafter Sizes

Roof rafter size and thickness shall be determined in accordance with the limits set forth in Table F3-1 based upon the horizontal projection of the *roof rafter span*. For determination of *roof rafter* sizes, *roof spans* are permitted to be reduced when a *roof rafter* support brace is installed in accordance with Section F3.2. The reduced *roof rafter span* shall be taken as the larger of the distance from the *roof rafter* support brace to the *ridge* or to the heel measured horizontally.

For the purpose of determining *roof rafter* sizes in Table F3-1, wind speeds shall be converted to equivalent ground snow load in accordance with Table F3-2. *Roof rafter* sizes shall be based on the higher of the ground snow load or the equivalent snow load converted from the wind speed.

F3.1.1 Eave Overhang

Eave overhangs shall not exceed 24 inches (610 mm) measured horizontally.

F3.1.2 Rake Overhang

Rake overhangs shall not exceed 12 inches (305 mm) measured horizontally. Outlookers at gable endwalls shall be installed in accordance with Figure F3-1.

F3.2 Roof Rafter Support Brace

When used to reduce *roof rafter spans* in determining *roof rafter* sizes, a *roof rafter* support brace shall meet all of the following conditions:

- (1) Minimum 350S162-33 *C-shaped* brace member with maximum length of 8 feet (2.44 m).
- (2) Minimum brace member slope of 45 degrees to the horizontal.
- (3) Minimum connection of brace to a *roof rafter* and *ceiling joist* with 4 No. 10 screws at each end.
- (4) Maximum 6 inches (152 mm) between brace/*ceiling joist* connection and structural wall

below.

- (5) Each *roof rafter* support brace greater than 4 feet (1.22 m) in length shall be braced with a supplemental brace having a minimum size of 350S162-33 or 350T162-33 such that the maximum unsupported length of the *roof rafter* support brace is 4 feet (1.22 m). The supplemental brace shall be continuous and shall be connected to each *roof rafter* support brace using 2 No. 8 screws.

F3.3 Roof Rafter Splice

Roof rafters shall not be spliced without an *approved* design. Splicing of *tracks* used as a fascia connected to the ends of rafters shall conform to Figure D6-1.

F3.4 Roof Rafter to Ceiling Joist and Ridge Member Connection

Roof rafters shall be connected to a parallel *ceiling joist* to form a continuous tie between exterior walls in accordance with Figures F2-2 or F2-3 and Table F2-3. *Ceiling joists* shall be connected to the top *track* of the structural wall in accordance with Table F2-4, either with the required number of No. 10 screws applied through the *flange* of the *ceiling joist* or by using a 54 mil (1.37 mm) *clip angle* with the required number of No. 10 screws in each leg. *Roof rafters* shall be connected to a *ridge* member with a minimum 2-inch x 2-inch (51x51 mm) *clip angle* fastened with No. 10 screws to the *ridge* member in accordance with Figure F3-2 and Table F3-3. The *clip angle* shall have a steel thickness equivalent to or greater than the *roof rafter* thickness and shall extend the depth of the *roof rafter* member to the extent possible. The *ridge* member shall be fabricated from a *C-shaped* member and a *track* section, which shall have a minimum size and steel thickness equivalent to or greater than that of adjacent *roof rafters* and shall be installed in accordance with Figure F3-2. The *ridge* member shall extend the full depth of the sloped *roof rafter* cut.

F3.5 Roof Rafter Bottom Flange Bracing

The bottom *flanges* of *roof rafters* shall be continuously braced, at a maximum spacing of 8 feet (2.44 m) as measured parallel to the *roof rafters*, with one of the following members:

- (a) Minimum 33 mil (0.84 mm) *C-shaped* member.
- (b) Minimum 33 mil (0.84 mm) *track* section.
- (c) Minimum 1-1/2 inch x 33 mil (38 x 0.84 mm) steel *strap*.

The *bracing* element shall be fastened to the bottom *flange* of each *roof rafter* with one No. 8 screw and shall be fastened to *blocking* with two No. 8 screws. *Blocking* shall be installed between *roof rafters* in-line with the continuous *bracing* at a maximum spacing of 12 feet (3.66 m) measured perpendicular to the *roof rafters*. The ends of continuous *bracing* shall be fastened to *blocking* or anchored to a stable building component with two No. 8 screws.

F4 Hip Framing

Hip framing shall consist of jack rafters, hip members, hip support columns and connections in accordance with this section or shall be in accordance with an *approved* design.

The provisions of this section for hip members and hip support columns shall only apply where the jack rafter slope is greater than or equal to the roof slope.

For the purpose of determining member sizes in this section, wind speeds shall be converted to equivalent ground snow load in accordance with Table F3-2. Member sizes shall be based on the higher of the ground snow load or the equivalent snow load converted from the wind speed.

F4.1 Jack Rafters

Jack rafters shall meet the requirements for *roof rafters* in accordance with Section F3, except the requirements in Section F3.4 shall not apply.

F4.2 Hip Members

Hip members shall be fabricated from a *C-shape* member and a *track* section, which shall have minimum sizes determined in accordance with Table F4-1. The *C-shaped* member and *track* section shall be connected at a maximum spacing of 24 inches using No. 10 screws through top and bottom *flanges*, as shown in Figure F3-2.

The depth of the hip member shall match that of the *roof rafters* and jack rafters, unless an *approved* beam pocket is provided at the corner of the supporting wall.

F4.3 Hip Support Columns

Hip support columns shall be used to support hip members at the *ridge*. A hip support column shall consist of a pair of *C-shapes*, with a minimum size determined in accordance with Table F4-2. The *C-shapes* shall be connected at a maximum spacing of 24 inches to form a box using minimum 3-inch x 33-mil strap connected to each of the *flanges* of the *C-shapes* with 3 No. 10 screws.

Hip support columns shall have a continuous load path to the foundation and shall be supported at the ceiling line by an interior wall or by an *approved* supporting element.

F4.4 Hip Framing Connections

Jack rafters shall be connected at the eave to a parallel *C-shape blocking* member in accordance with Figure F4-1. In other than *high wind areas*, the *C-shape blocking* member shall be attached to the supporting wall *track* with minimum 2-No. 10 screws. In *high wind areas*, the *C-shape blocking* member shall be attached to the supporting wall in accordance with Section F7.2.

Jack rafters shall be connected to a hip member with a minimum 2-inch x 2-inch (51-mm x 51-mm) *clip angle* fastened with No. 10 screws to the hip member in accordance with Figure F3-2 and Table F3-3. The clip angle shall have a steel thickness equivalent to or greater than the jack rafter thickness and shall extend the depth of the jack rafter member to the extent possible.

The connection of hip support columns at the ceiling line shall be in accordance with Figure F4-2, with an uplift strap sized in accordance with Table F4-3.

The connection of hip members, *ridge* members and hip support columns at the *ridge* shall be in accordance with Figures F4-3 and F4-4 and Table F4-4.

The connection of hip members to the wall corner shall be in accordance with Figure F4-5 and Table F4-5.

F5 Framing of Openings in Roofs and Ceilings

Openings in roofs and ceilings shall not exceed the lesser of 8 feet (2.44 m) or 50 percent of the parallel building dimension.

Openings in roofs and ceilings shall be framed with *header* and *trimmer joists*. *Header* and *trimmer joists* shall be framed in accordance with Figure F5-1 and installed in accordance with Figure F5-2. *Header* and *trimmer joists* shall be fabricated from *joist* and *track* members having a minimum size and thickness at least equivalent to the adjacent *ceiling joists* or *roof rafters*, except *header joist* for spans greater than 4 feet (1.22 m) shall be determined in accordance with Tables F5-1 through F5-4. *Track* sections shall be the same thickness as the *C-shape* listed in the tables.

Each *track* section for a built-up *header* or trimmer *joist* shall extend the full length of the *joist* (continuous). Each *header joist* shall be connected to trimmer *joists* with a minimum of four 2-inch x 2-inch (51-mm x 51-mm) *clip angles*. Each *clip angle* shall be fastened to both the *header* and trimmer *joists* with 4 No. 8 screws, evenly spaced, through each leg of the *clip angle*. The *clip angles* shall have a steel thickness not less than that of the *ceiling joist* or *roof rafter*.

A built-up trimmer *joist* consisting of at least a pair of *C-shape* members shall be supported by a pair of wall *studs* beneath. Trimmer *joists* are to be provided with *bearing stiffeners* and shall be installed at each bearing support in accordance with Section B2 and Figure F2-3

F6 Roof Trusses

Trusses shall be designed and installed in accordance with Chapter E of AISI S240.

Trusses shall be connected to the top *track* of the structural wall in accordance with Table F2-4, either with the required number of No. 10 screws applied through the *flange* of the *truss* or by using a 54 mil (1.37 mm) *clip angle* with the required number of No. 10 screws in each leg.

F7 Ceiling and Roof Diaphragms

At gable endwalls, a ceiling *diaphragm* shall be provided by attaching a minimum 1/2-inch (13-mm) gypsum board in accordance with Tables F7-1 and F7-2 or a minimum 3/8-inch (9.5-mm) wood structural panel sheathing, which complies with DOC PS 1, DOC PS 2, CSA O437, or CSA O325, in accordance with Table F7-3 and F7-4 to the bottom of *ceiling joists* or *roof trusses* and connected to wall framing in accordance with Figures F7-1 and F7-2, unless *studs* are designed as full-height without bracing at the ceiling. Flat *blocking* shall consist of *C-shape* or *track* section with a minimum thickness of 33 mils (0.84 mm).

The ceiling *diaphragm* shall be secured with screws spaced at a maximum 6 inches (152 mm) o.c. at panel edges and a maximum 12 inches (305 mm) o.c. in the field. The required lengths in Table F7-1 and F7-2 for gypsum board sheathed ceiling *diaphragms* is permitted to be multiplied by 0.35 if all panel edges are blocked. The required lengths in Table F7-1 and Table F7-2 for gypsum board sheathed ceiling *diaphragms* is permitted to be multiplied by 0.9 if all panel edges are secured with screws spaced at 4 inches (102 mm) o.c.

A roof *diaphragm* shall be provided by attaching a minimum of 3/8 inch (9.5 mm) wood structural panel, which complies with DOC PS 1, DOC PS 2, CSA O437 or CSA O325 to *roof rafters* or *truss* top chords in accordance with Tables F2-4 and F2-5. Buildings with 3:1 or larger *plan aspect ratio* and with *roof rafters* slope (pitch) of 9:12 or larger shall have the *roof rafters* and *ceiling joists* blocked in accordance with Figure F7-3.

F7.1 Roof Diaphragms in High Seismic Areas

Roof *diaphragms* in *high seismic areas* shall be constructed with the provisions of this section.

Roof *diaphragms* shall be constructed of minimum 3/8-inch (9.5-mm) C-D or C-C Sheathing with screws at 6-inch (152-mm) spacing on panel edges and in the field. The *diaphragms* are permitted to be unblocked, and are permitted to be constructed in any panel configuration except in the case of a building in *Seismic Design Category D₂*, where a heavy roof system is used and the *diaphragm span* is greater than or equal to 40 feet (12.2 m).

In *Seismic Design Category D₂*, where a heavy roof system is used on a building with a *diaphragm span* greater than or equal to 40 feet (12.2 m), the roof *diaphragm* shall be constructed of 15/32 inch (12 mm) Structural I Plywood, unblocked, and in any configuration, with screws at 6-inch (152 mm) spacing on panel edges and at maximum 12 inch (305 mm) spacing in the field. Alternatively, it is permitted to use 3/8-inch (9.5 mm) C-D or C-C Sheathing with screws at 6-inch (152 mm) spacing on panel edges and in the field,

with all unblocked edges and continuous panel joints parallel to the longer *diaphragm span*.

F7.2 Roof Diaphragms in High Wind Areas

In *high wind areas*, roof *diaphragms* shall be constructed of minimum 3/8-inch (9.5 mm) C-D or C-C Sheathing with screws spaced as indicated in Table F2-5. The *diaphragms* are permitted to be unblocked, and are permitted to be constructed in any panel configuration.

F8 Roof Framing Connections in High Wind Areas

F8.1 General

In *high wind areas*, connection of the roof framing members shall be provided, in accordance with this section to ensure a continuous load path capable of transferring shear and uplift loads from floors, *studs*, and roof framing to the foundation.

F8.2 Uplift Connection - Roof Rafter or Truss to Wall

Roof rafters and *trusses* shall be attached to their supporting wall assemblies by connections capable of resisting the uplift loads listed in Table F8-1. Alternatively, a steel uplift *strap* sized in accordance with Table F8-5 connecting the *roof rafter* or *truss* to the *in-line framing stud* below is permitted. Each end of the uplift *strap* shall be fastened with minimum No. 8 screws as required by Table F8-2.

F8.3 Ridge Strap Connection

Roof rafters shall be provided with a connection at the *ridge* line to transfer tension loads. The *ridge* connection shall be capable of resisting the unit loads listed in Table F8-3 multiplied by the appropriate spacing multiplier listed in Table F8-4. Alternatively, a steel *ridge strap* sized in accordance with Table F8-5 shall be provided with minimum No. 8 screws on each end of the *strap* as required in Table F8-3. The number of screws shall be increased to account for the spacing multipliers shown in Table F8-4.

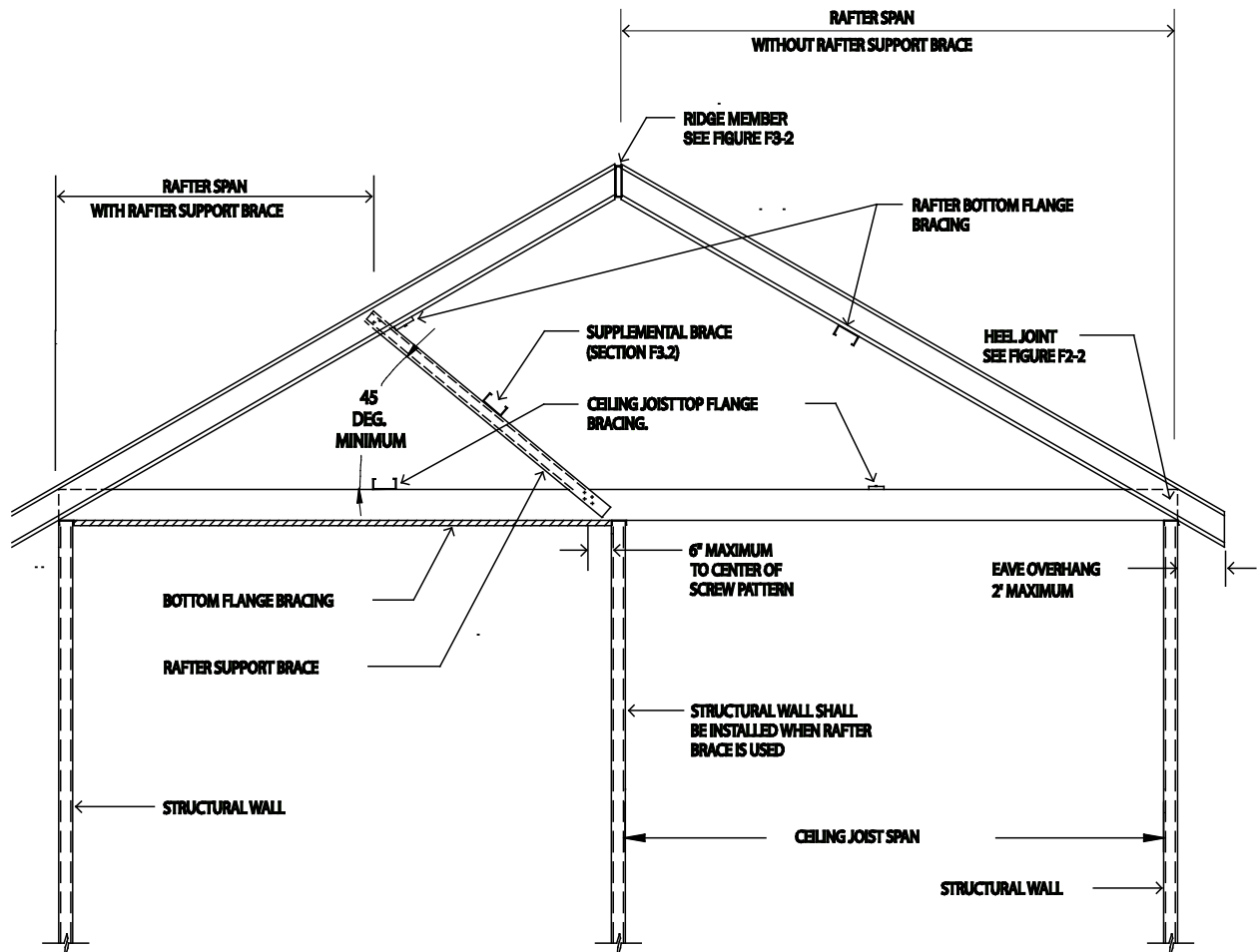

Figure F2-1 Roof Construction

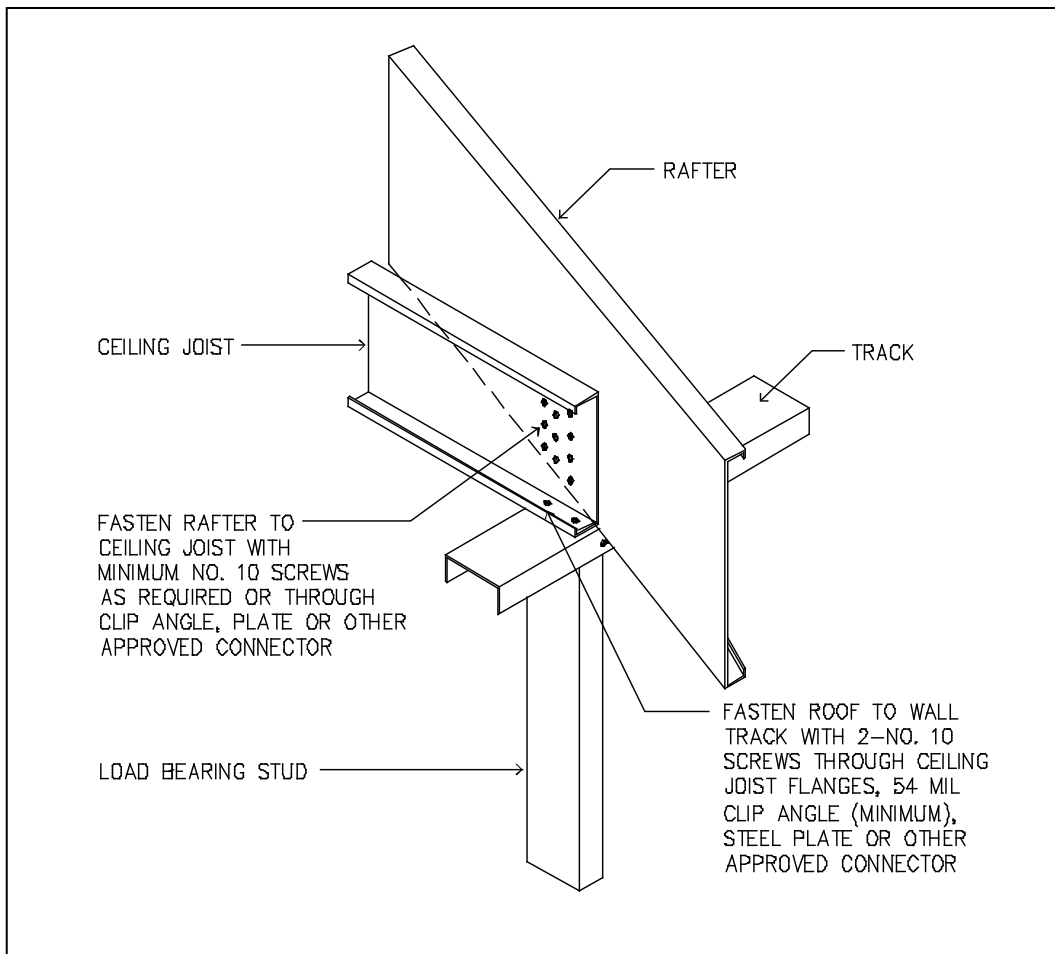

Figure F2-2 Heel Joint Connection

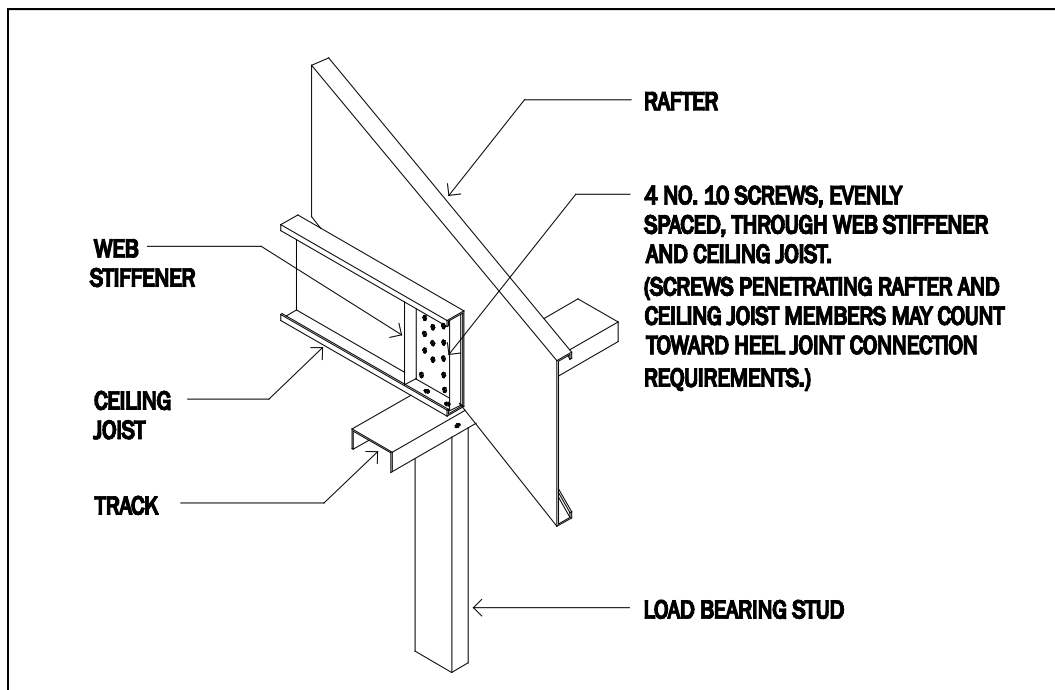

Figure F2-3 Bearing Stiffener at the Heel Joint Connection

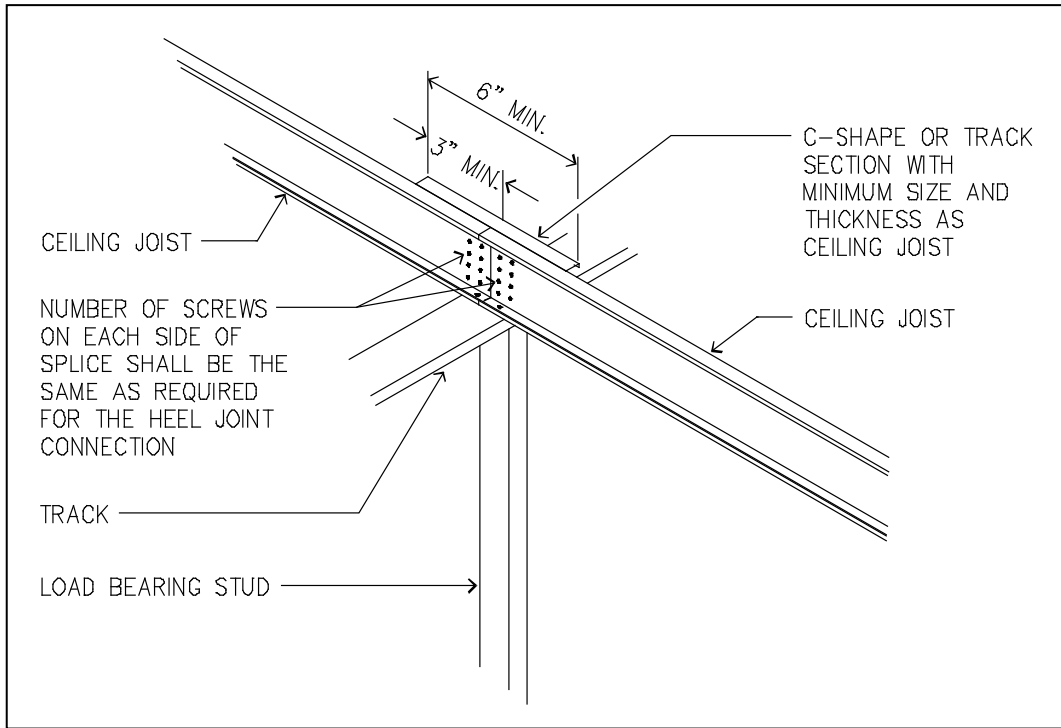

Figure F2-4 Spliced Ceiling Joists

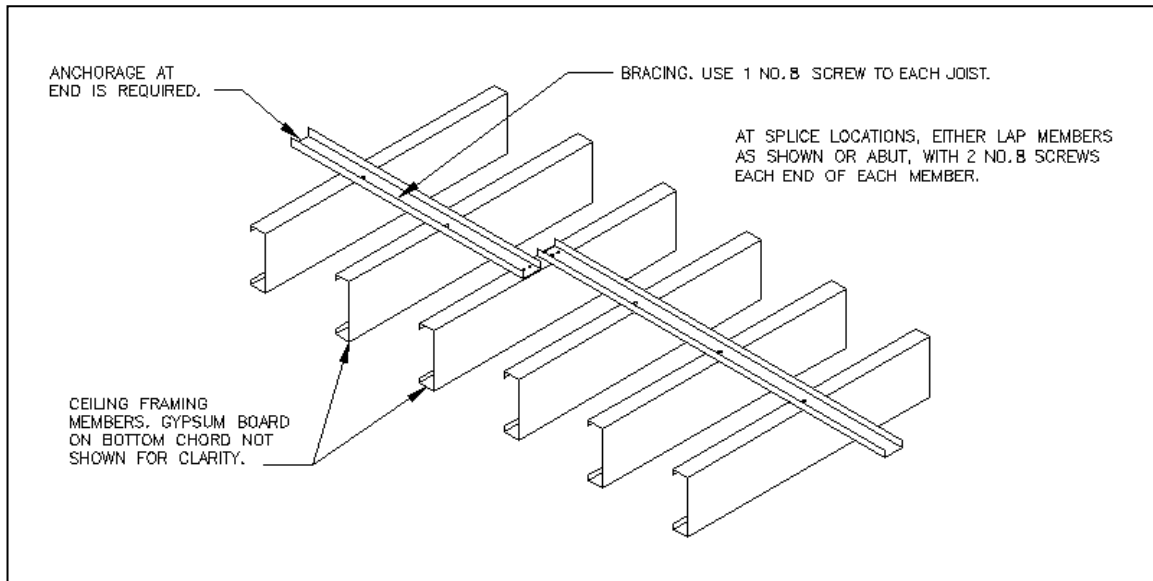

Figure F2-5 Ceiling Joist Top Flange Bracing with C-Shape, Track or Cold-Rolled Channel

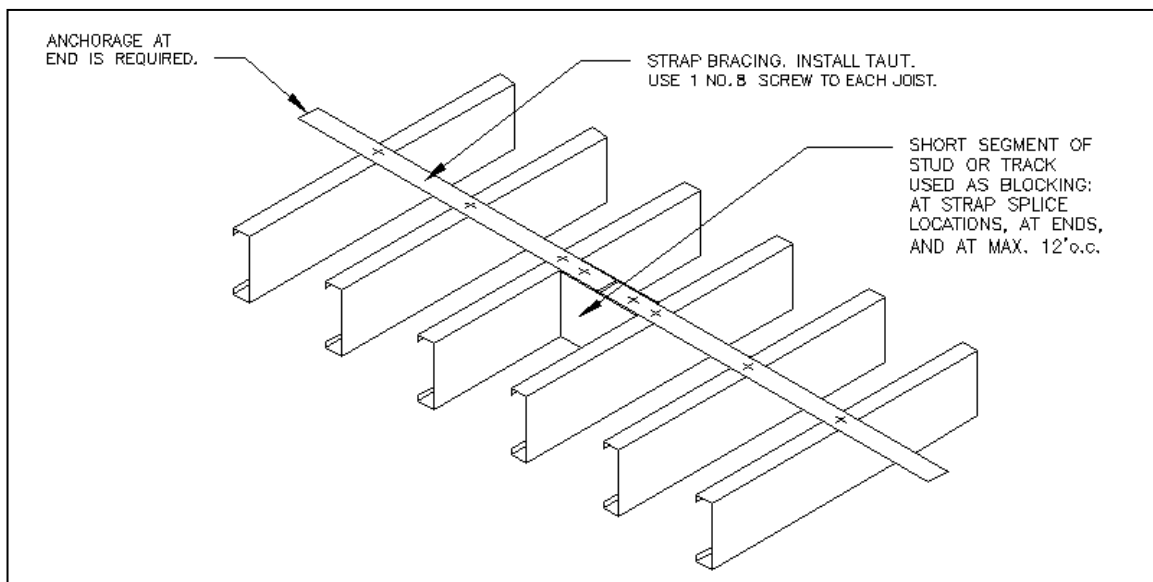

Figure F2-6 Ceiling Joist Top Flange Bracing with Continuous Steel Strap and Blocking

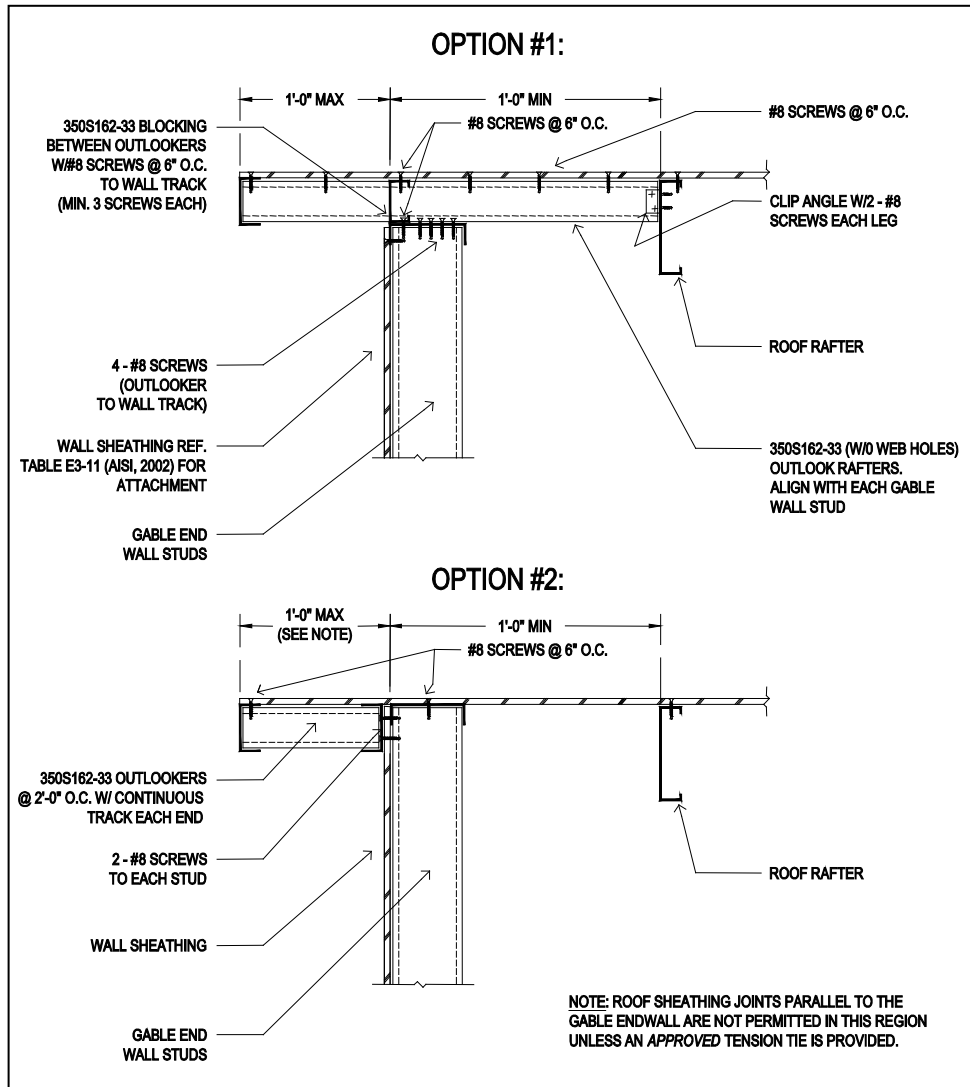

Figure F3-1 Gable Endwall Overhang Details

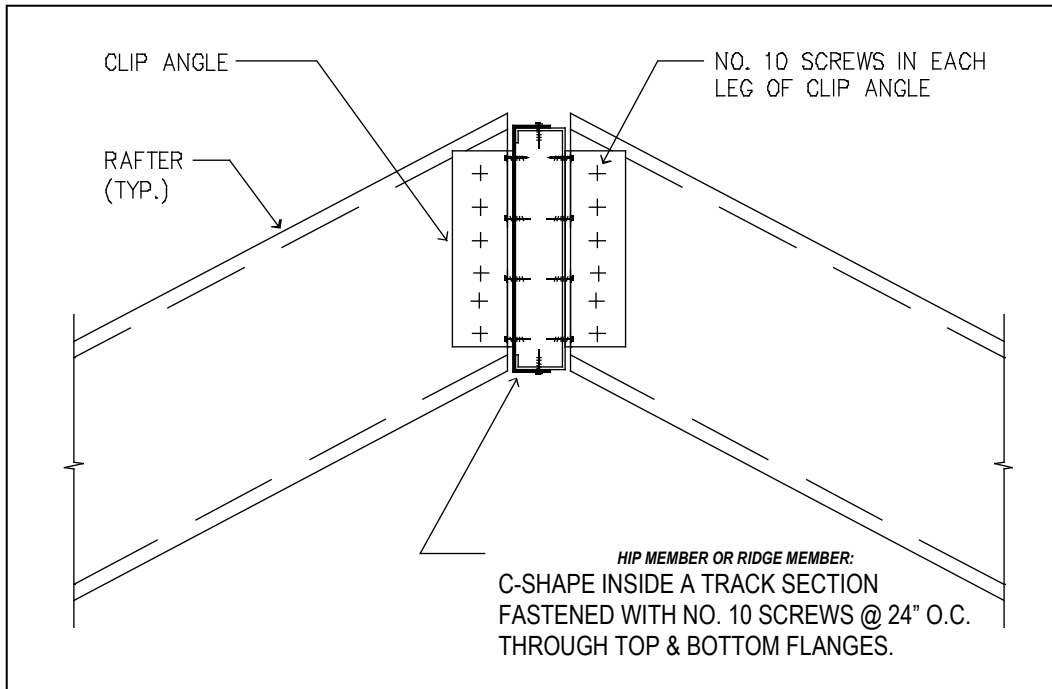

Figure F3-2 Hip Member or Ridge Member Connection

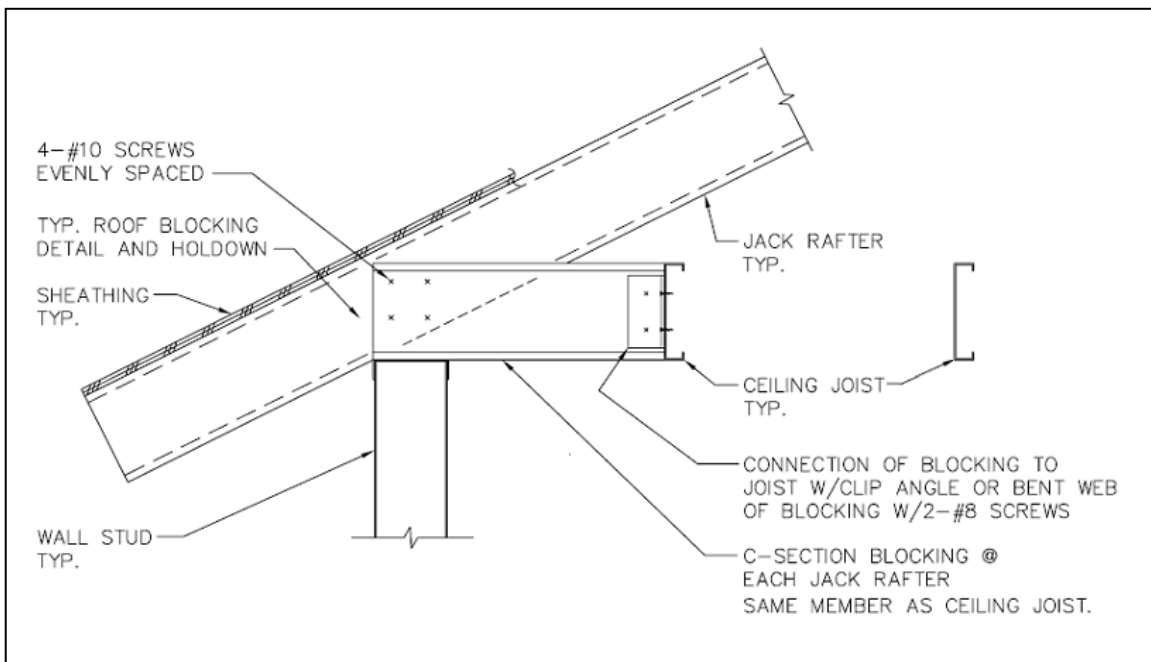

Figure F4-1 Jack Rafter Connection at Eave

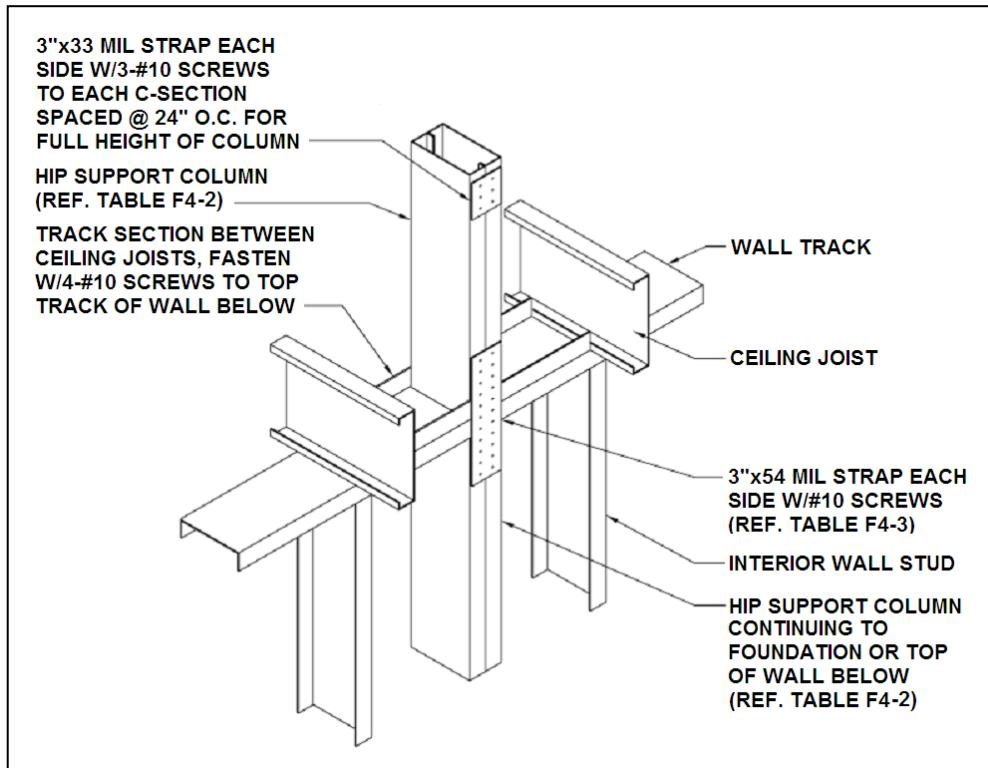

Figure F4-2 Hip Support Column

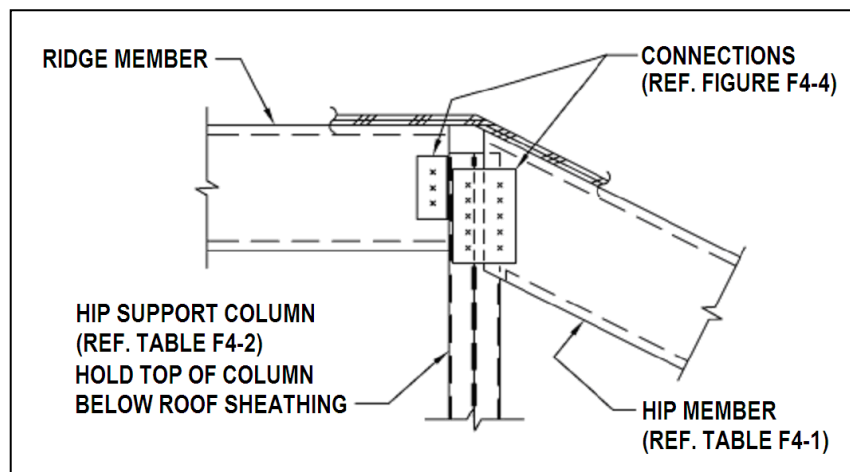

Figure F4-3 Hip Connections at Ridge

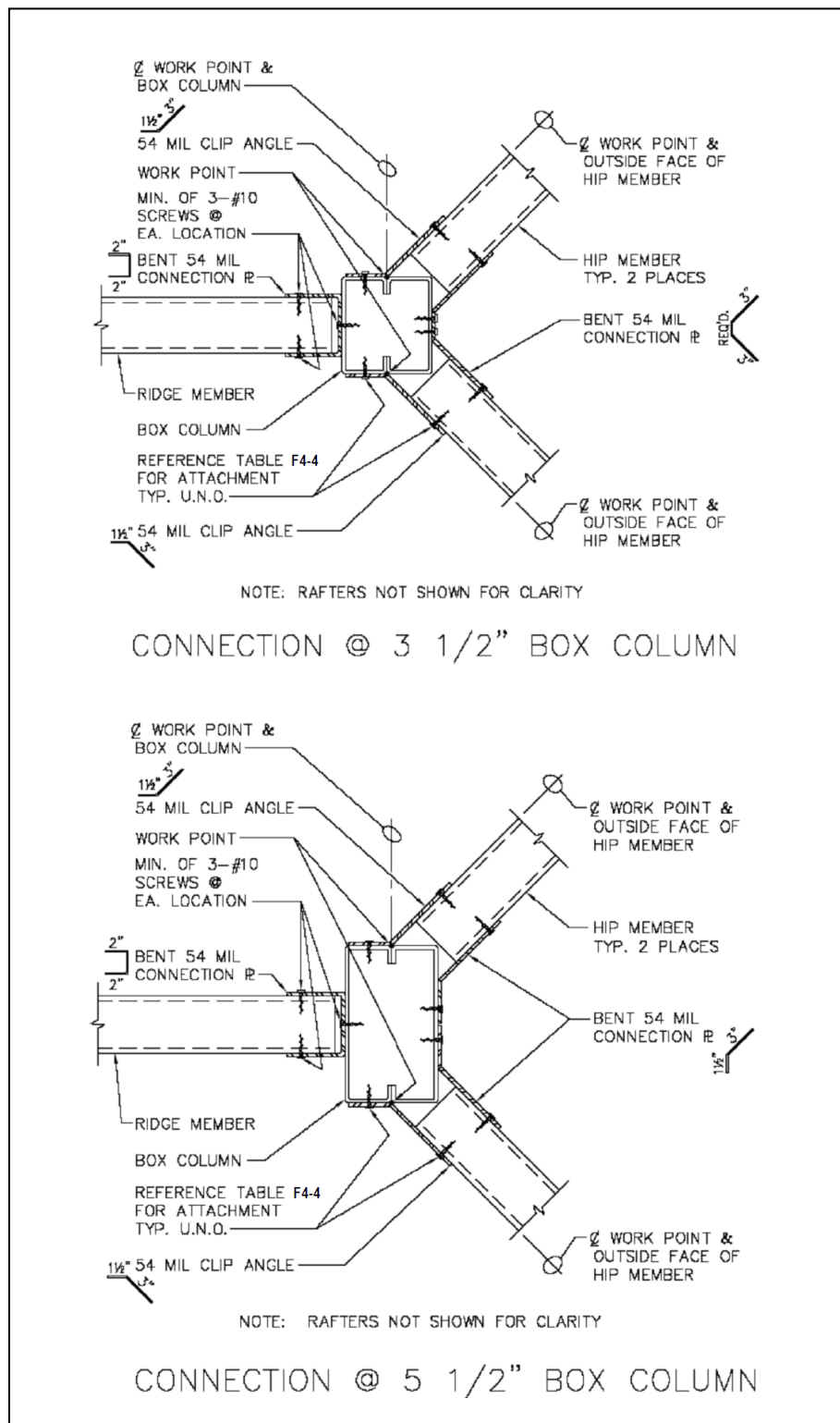

Figure F4-4 Hip Connections at Ridge and Box Column

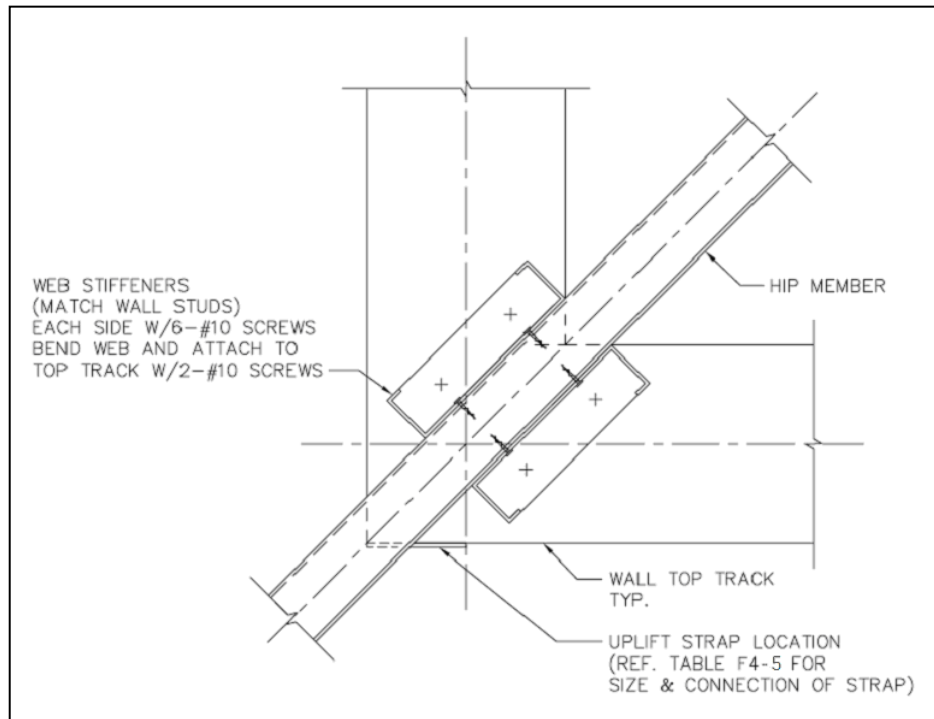

Figure F4-5 Hip Member Connection at Wall Corner

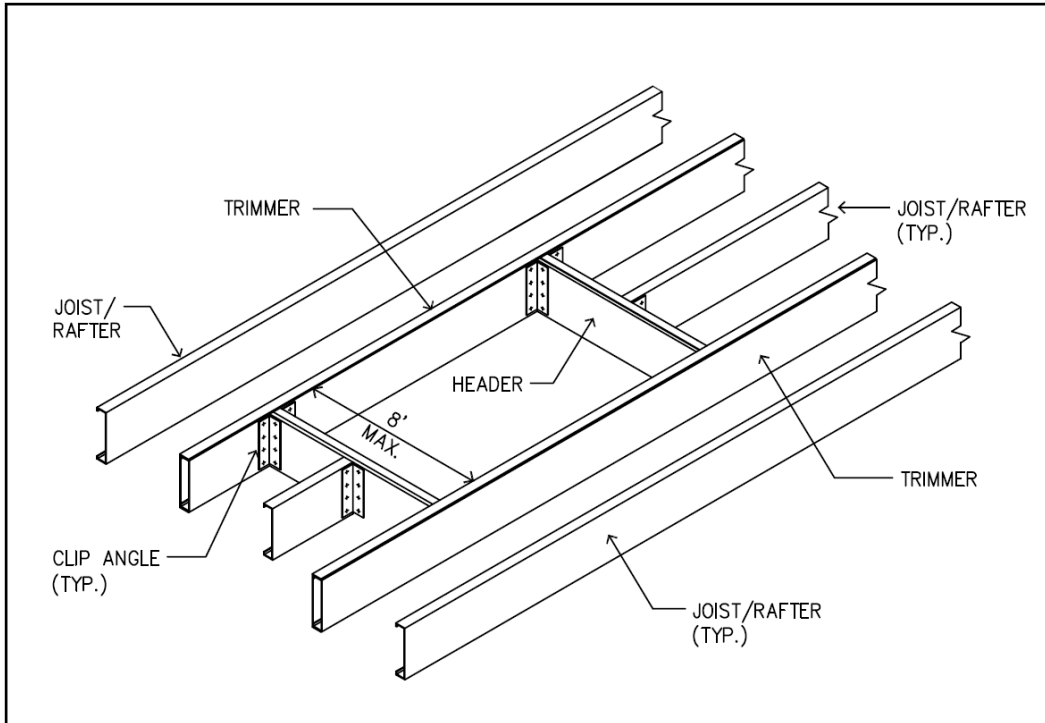

Figure F5-1 Roof or Ceiling Opening

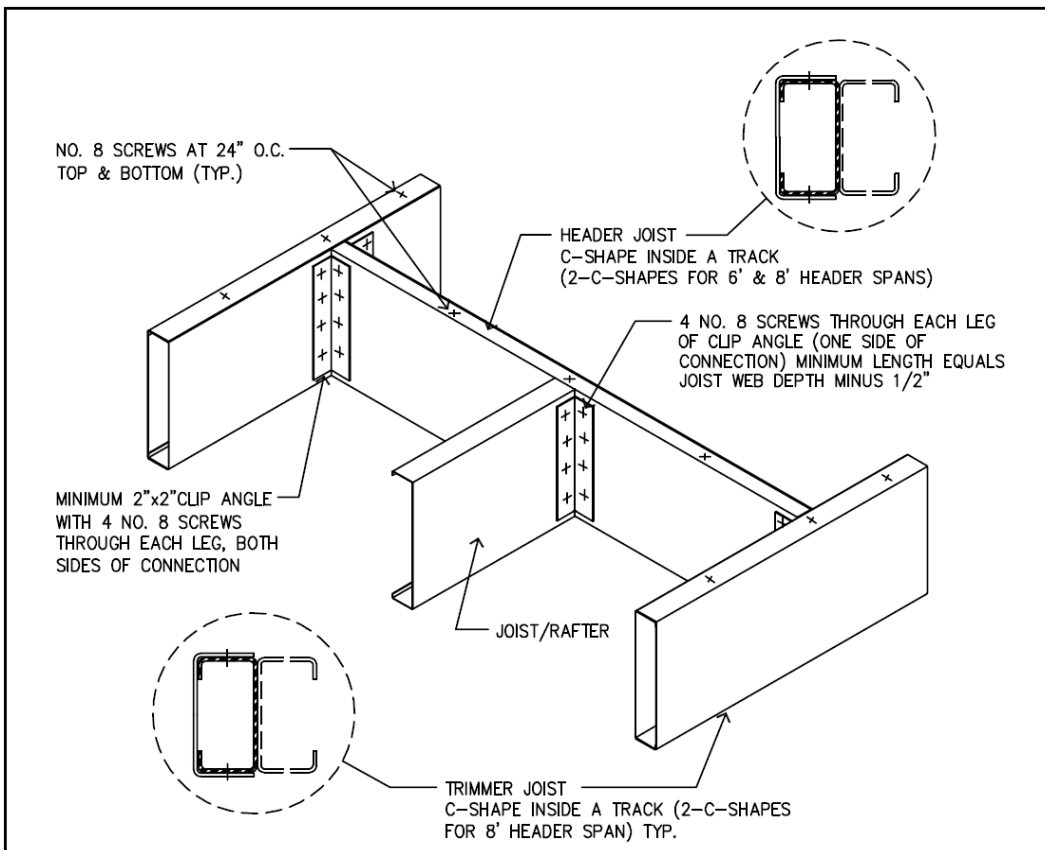

Figure F5-2 Header to Trimmer Detail

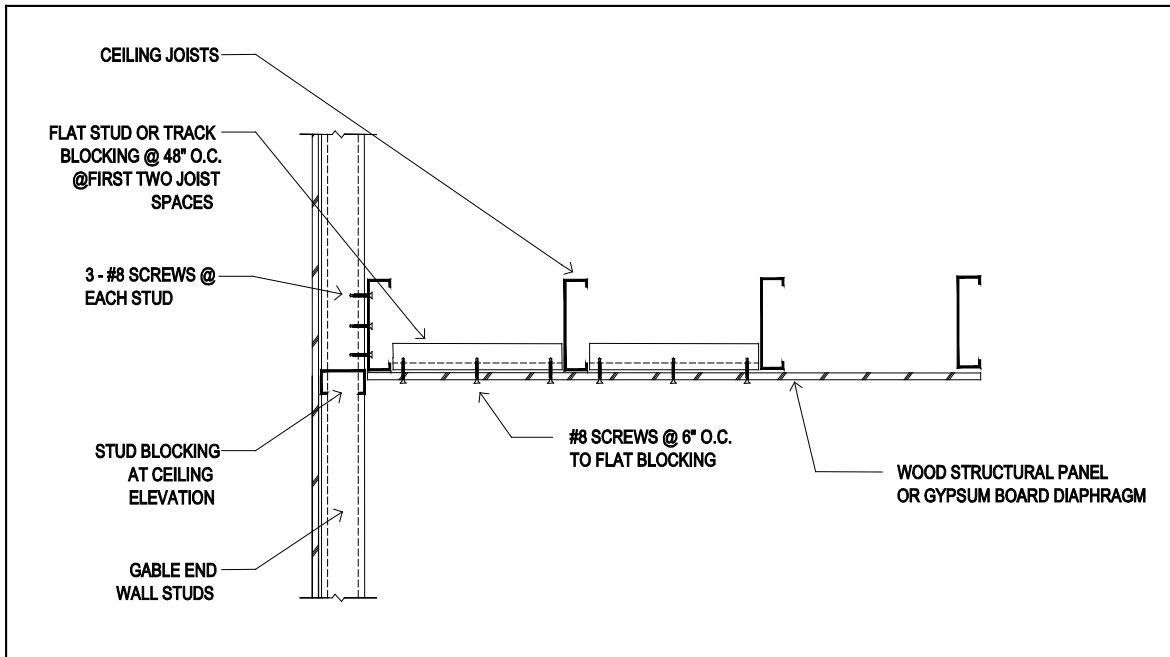

Figure F7-1 Ceiling Diaphragm to Gable Endwall Detail

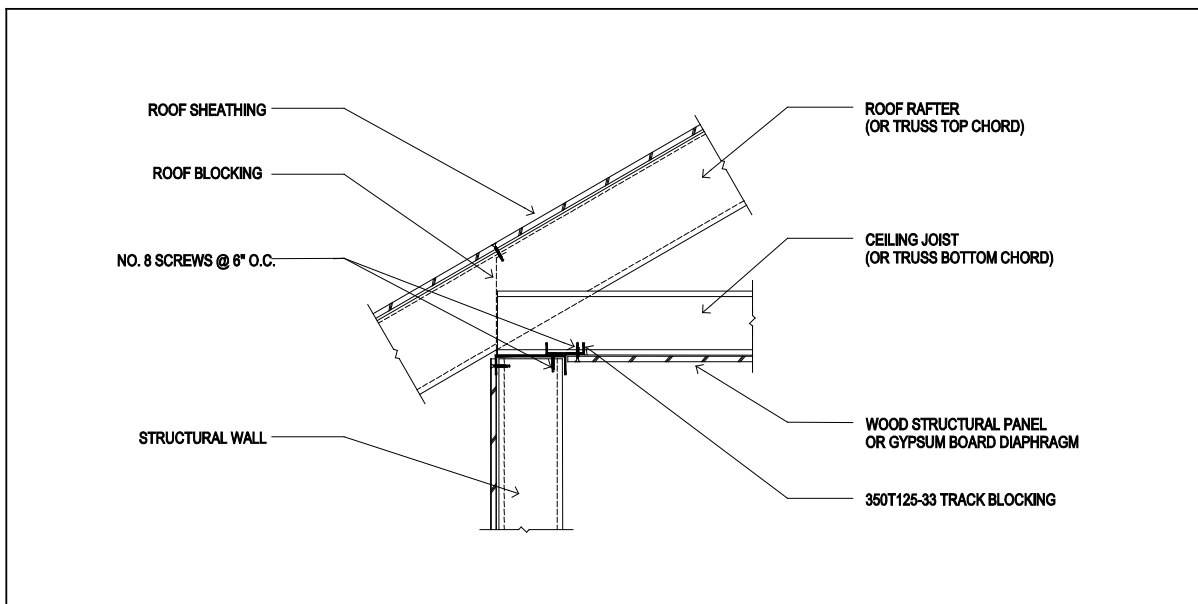

Figure F7-2 Ceiling Diaphragm to Sidewall Detail

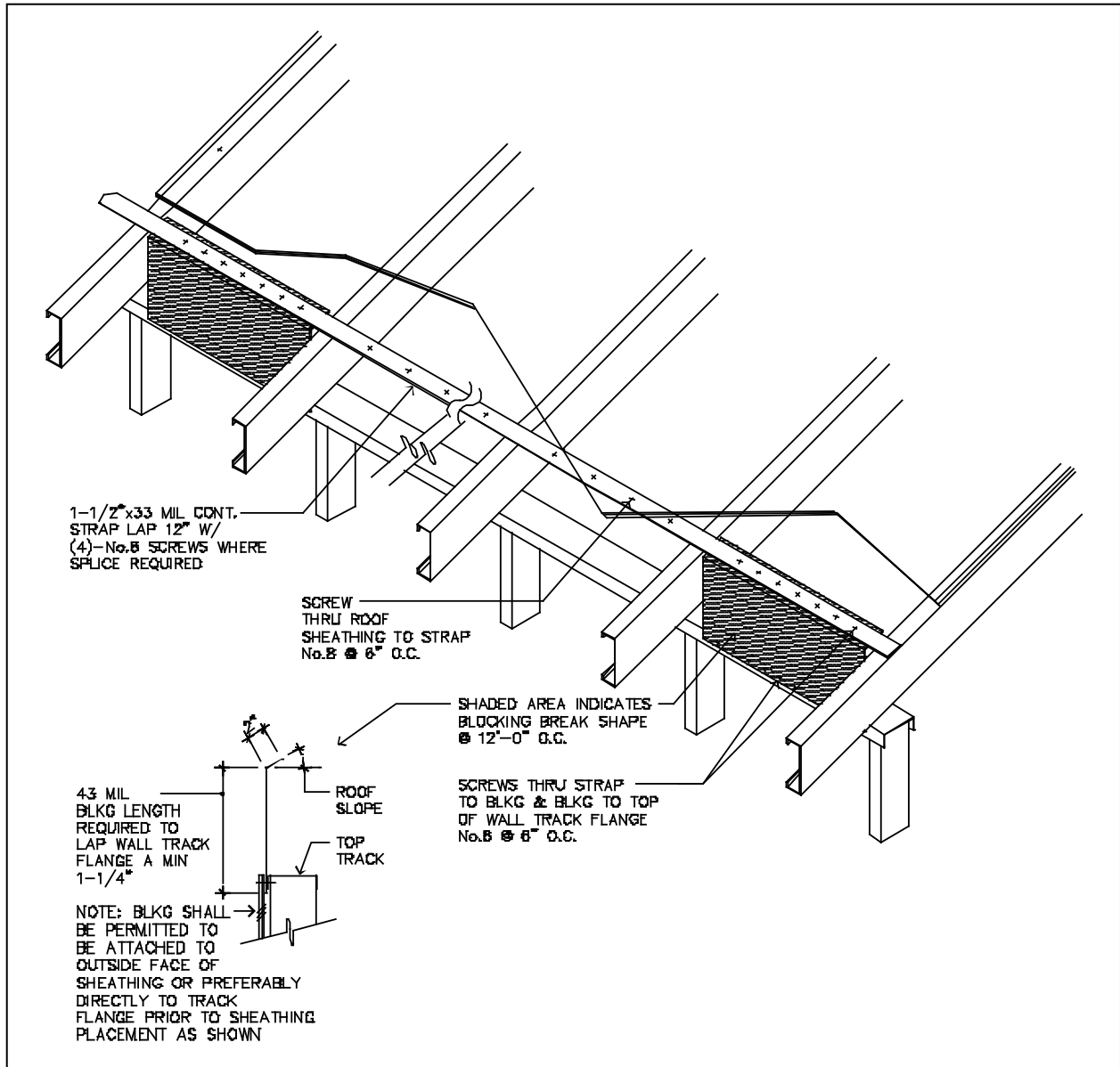

Figure F7-3 Roof Blocking Detail

Table F2-1
Ceiling Joist Spans
Single Spans Without Bearing Stiffeners
10 lbs per Square Foot Live Load (No Attic Storage) ^{1,2,3,4}

Member Designation	Allowable Span (Feet-Inches)					
	Lateral Support of Top (Compression) Flange					
	Unbraced		Mid-Span Bracing		Third-Point Bracing	
	Ceiling Joist Spacing (inches)					
	16	24	16	24	16	24
350S162-33	9'-6"	8'-6"	11'-10"	9'-10"	11'-10"	10'-4"
350S162-43	10'-4"	9'-3"	12'-10"	11'-3"	12'-10"	11'-3"
350S162-54	11'-1"	9'-11"	13'-9"	12'-0"	13'-9"	12'-0"
350S162-68	12'-2"	10'-10"	14'-9"	12'-10"	14'-9"	12'-10"
350S162-97	14'-3"	12'-7"	16'-3"	14'-2"	16'-3"	14'-2"
550S162-33	10'-11"	9'-10"	15'-7"	12'-0"	16'-10"	12'-0"
550S162-43	11'-8"	10'-6"	16'-10"	14'-10"	18'-4"	16'-0"
550S162-54	12'-7"	11'-3"	18'-0"	16'-2"	19'-4"	17'-2"
550S162-68	13'-7"	12'-1"	19'-3"	17'-3"	20'-6"	18'-5"
550S162-97	15'-9"	13'-11"	21'-8"	19'-3"	22'-5"	20'-4"
800S162-43	13'-1"	11'-9"	18'-9"	16'-9"	21'-2"	18'-7"
800S162-54	13'-11"	12'-6"	20'-1"	18'-1"	21'-5"	20'-5"
800S162-68	14'-11"	13'-4"	21'-4"	19'-2"	22'-9"	21'-9"
800S162-97	17'-1"	15'-2"	23'-9"	21'-3"	24'-10"	23'-10"
1000S162-54	14'-10"	13'-4"	21'-4"	19'-2"	22'-8"	21'-8"
1000S162-68	15'-10"	14'-3"	22'-9"	20'-5"	24'-3"	23'-3"
1000S162-97	17'-11"	16'-0"	25'-2"	22'-6"	26'-4"	25'-4"
1200S162-68	16'-8"	14'-11"	23'-11"	21'-7"	25'-5"	24'-5"
1200S162-97	18'-9"	16'-8"	26'-5"	23'-8"	27'-7"	26'-8"

For SI: 1 inch = 25.4 mm, 1 foot = 0.305 m, 1 psf = 0.0479 kN/m²

¹ Ceiling dead load = 5 psf (0.24 kN/m²)

² Deflection criteria: L/240 for total loads

³ The minimum *yield strength*, F_y , of cold-formed steel framing members is 50 ksi (340 MPa) for members with a *designation thickness* equal to or greater than 54 mils.

⁴ Table F2-1 is not applicable for 350S162-33, 550S162-33, 550S162-43 and 800S162-43 continuous joist members.

Table F2-2
Ceiling Joist Spans
Single Spans Without Bearing Stiffeners
20 lbs per Square Foot Live Load (Limited Attic Storage) ^{1,2,3,4}

Member Designation	Allowable Span (Feet-Inches)					
	Lateral Support of Top (Compression) Flange					
	Unbraced	Mid-Span Bracing		Third-Point Bracing		
	Ceiling Joist Spacing (inches)					
	16	24	16	24	16	24
350S162-33	8'-0"	6'-5"	9'-2"	7'-5"	9'-11"	7'-5"
350S162-43	8'-11"	7'-8"	10'-9"	8'-9"	10'-10"	9'-6"
350S162-54	9'-7"	8'-7"	11'-7"	10'-2"	11'-7"	10'-2"
350S162-68	10'-4"	9'-3"	12'-5"	10'-10"	12'-5"	10'-10"
350S162-97	12'-1"	10'-8"	13'-8"	12'-0"	13'-8"	12'-0"
550S162-33	9'-5"	6'-11"	10'-5"	6'-11"	10'-5"	6'-11"
550S162-43	10'-2"	9'-2"	14'-2"	11'-8"	15'-2"	11'-8"
550S162-54	10'-10"	9'-9"	15'-7"	14'-0"	16'-7"	14'-5"
550S162-68	11'-8"	10'-5"	16'-7"	14'-10"	17'-9"	15'-6"
550S162-97	13'-4"	11'-10"	18'-6"	16'-7"	19'-8"	17'-2"
800S162-43	11'-4"	10'-2"	16'-1"	11'-0"	16'-6"	11'-0"
800S162-54	12'-0"	10'-10"	17'-4"	15'-7"	18'-7"	17'-7"
800S162-68	12'-10"	11'-6"	18'-6"	16'-7"	19'-11"	18'-11"
800S162-97	14'-6"	12'-11"	20'-5"	18'-3"	21'-7"	20'-7"
1000S162-54	12'-10"	11'-7"	18'-5"	16'-6"	19'-8"	18'-8"
1000S162-68	13'-8"	12'-3"	19'-8"	17'-9"	21'-1"	20'-1"
1000S162-97	15'-4"	13'-8"	21'-8"	19'-5"	22'-11"	21'-11"
1200S162-68	14'-5"	12'-11"	20'-9"	18'-7"	22'-0"	21'-0"
1200S162-97	16'-1"	14'-4"	22'-10"	20'-5"	24'-2"	23'-2"

For SI: 1 inch = 25.4 mm, 1 foot = 0.305 m, 1 psf = 0.0479 kN/m²

¹ Ceiling dead load = 5 psf (0.24 kN/m²)

² Deflection criteria: L/240 for total loads

³ The minimum yield strength, F_y , of cold-formed steel framing members is 50 ksi (340 MPa) for members with a designation thickness equal to or greater than 54 mils.

⁴ Table F2-2 is not applicable for 350S162-33, 350S162-43, 550S162-33, 550S162-43 and 800S162-43 continuous joist members.

Table F2-3
Screws Required for Ceiling Joist to Roof Rafter Connections¹

Roof Slope	Number of Screws																			
	Building Width (feet)																			
	24'					28'				32'				36'				40'		
	Ground Snow Load (psf)																			
	20	30	50	70	20	30	50	70	20	30	50	70	20	30	50	70	20	30	50	70
3/12	5	6	9	11	5	7	10	13	6	8	11	15	7	8	13	17	8	9	14	19
4/12	4	5	7	9	4	5	8	10	5	6	9	12	5	7	10	13	6	7	11	14
5/12	3	4	6	7	4	4	6	8	4	5	7	10	5	5	8	11	5	6	9	12
6/12	3	3	5	6	3	4	6	7	4	4	6	8	4	5	7	9	4	5	8	10
7/12	3	3	4	6	3	3	5	7	3	4	6	7	4	4	6	8	4	5	7	9
8/12	2	3	4	5	3	3	5	6	3	4	5	7	3	4	6	8	4	4	6	8
9/12	2	3	4	5	3	3	4	6	3	3	5	6	3	4	5	7	3	4	6	8
10/12	2	2	4	5	2	3	4	5	3	3	5	6	3	3	5	7	3	4	6	7
11/12	2	2	3	4	2	3	4	5	3	3	4	6	3	3	5	6	3	4	5	7
12/12	2	2	3	4	2	3	4	5	2	3	4	5	3	3	5	6	3	4	5	7

For SI: 1 foot = 0.305 m, 1 psf = 0.0479 kN/m²

¹ Screws are minimum No. 10.

**Table F2-4
Roof Framing Fastening Schedule**

Description of Building Elements		Number and Size of Fasteners ¹				Number and Spacing of Fasteners	
Roof sheathing (oriented strand board or plywood) to <i>roof rafter</i> or <i>truss</i>		No. 8 screws				Refer to Table F2-5 for screw spacing (6" o.c. minimum at gable end <i>truss</i>)	
Gypsum board to <i>ceiling joists</i>		No. 6 screws				12" on center	
Gable end <i>truss</i> to endwall top <i>track</i>		No. 10 screws				12" o.c.	
<i>Roof rafter</i> to <i>ceiling joist</i> and to <i>ridge member</i>		No. 10 screws				See Tables F2-3 and F3-3	
Ceiling joist or roof truss to top track of structural wall ²	Ceiling Joist or Truss Spacing (in)	Roof Span (ft)	Wind Speed (mph), Exposure				Each ceiling joist or roof truss
			130 B 115 C	140 B 120 C	130 C	< 140 C	
	16	24	3	3	4	5	
		28	3	3	4	5	
		32	3	4	5	6	
		36	4	4	5	6	
		40	4	4	6	7	
	24	24	4	5	6	7	
		28	4	5	6	8	
		32	4	6	7	8	
		36	5	6	8	9	
40		6	6	8	10		

For SI: 1 inch = 25.4 mm, 1 foot = 0.305 m, 1 psf = 0.0479 kN/m²

¹ Screws are minimum No. 10 unless noted otherwise.

² Screws are to be applied through the *flanges* of the *truss* or *ceiling joist*, or a 54-mil (1.37-mm) *clip angle* is to be used with 2 No. 10 screws in each leg.

Table F2-5
Minimum Roof Sheathing Attachment for Wind Loads ¹

Wind Speed (mph)	Rafter Spacing (inches)	Roof Area			
		Interior Zone ³		Edge Zone ²	
		Exposure B	Exposure C	Exposure B	Exposure C
115	16	6/12	6/12	6/12	6/12
	24	6/12	6/12	6/12	6/6
120	16	6/12	6/12	6/12	6/12
	24	6/12	6/12	6/12	6/6
130	16	6/12	6/12	6/12	6/12
	24	6/12	6/12	6/12	6/6
140	16	6/6	6/6	6/6	6/6
	24	6/6	6/6	6/6	6/6
150	16	6/6	6/6	6/6	6/6
	24	6/6	6/6	6/6	6/6
160	16	6/6	6/6	6/6	6/6
	24	6/6	6/6	6/6	4/4
170	16	6/6	6/6	6/6	6/6
	24	6/6	6/6	6/6	4/4
180	16	6/6	6/6	6/6	6/6
	24	6/6	6/6	6/6	4/4

For SI: 1 inch = 25.4 mm, 1 foot = 0.305 m, 1 mph = 1.61 km/hr

¹ Values are for screw spacing in inches at panel edges and in the field (i.e., 6/12 = 6" o.c. edge and 12" o.c. field).

² Edge zone attachment is for sheathing located within 4 feet of the roof perimeter or 4 feet either side of the ridge and hips.

³ Interior zone attachment is for sheathing not designated as an edge zone.

Table F3-1
Roof Rafter Spans^{1,2,3,4}

Member Designation	Allowable Span Measured Horizontally (Feet-Inches)							
	Equivalent Ground Snow Load							
	20 psf		30 psf		50 psf		70 psf	
	Roof Rafter Spacing (in.)							
	16	24	16	24	16	24	16	24
550S162-33	13'-11"	11'-4"	11'-9"	9'-7"	9'-5"	7'-8"	8'-1"	6'-7"
550S162-43	15'-9"	13'-8"	14'-3"	11'-8"	11'-4"	9'-3"	9'-9"	7'-11"
550S162-54	16'-11"	14'-10"	15'-3"	13'-4"	13'-3"	11'-7"	12'-0"	10'-6"
550S162-68	18'-2"	15'-10"	16'-5"	14'-4"	14'-3"	12'-5"	12'-11"	11'-3"
550S162-97	20'-1"	17'-7"	18'-2"	15'-10"	15'-9"	13'-9"	14'-3"	12'-5"
800S162-33	16'-4"	13'-4"	13'-11"	11'-4"	11'-1"	9'-0"	9'-6"	6'-7"
800S162-43	19'-7"	16'-0"	16'-8"	13'-7"	13'-4"	10'-10"	11'-5"	9'-4"
800S162-54	22'-9"	19'-11"	20'-7"	17'-11"	17'-10"	14'-9"	15'-6"	12'-7"
800S162-68	24'-7"	21'-6"	22'-2"	19'-5"	19'-3"	16'-10"	17'-5"	14'-8"
800S162-97	27'-4"	23'-10"	24'-8"	21'-6"	21'-5"	18'-8"	19'-4"	16'-11"
1000S162-43	22'-2"	18'-1"	18'-10"	15'-4"	15'-1"	12'-4"	12'-11"	10'-7"
1000S162-54	27'-1"	23'-8"	24'-6"	20'-9"	20'-5"	16'-8"	17'-6"	14'-3"
1000S162-68	29'-5"	25'-8"	26'-6"	23'-2"	23'-0"	19'-6"	20'-6"	16'-9"
1000S162-97	32'-11"	28'-9"	29'-8"	25'-11"	25'-9"	22'-6"	23'-4"	20'-5"
1200S162-54	31'-3"	27'-0"	28'-1"	22'-11"	22'-6"	18'-4"	19'-4"	15'-9"
1200S162-68	34'-0"	29'-8"	30'-8"	26'-9"	26'-6"	21'-7"	22'-8"	18'-6"
1200S162-97	38'-6"	33'-6"	34'-8"	30'-3"	30'-1"	26'-3"	27'-3"	23'-1"

For SI: 1 inch = 25.4 mm, 1 mil = 0.0254 mm, 1 foot = 0.305 m, 1 psf = 0.0479 kN/m²

¹ Table provides maximum horizontal *roof rafter spans* in feet & inches for slopes between 3:12 & 12:12

² Deflection criteria: L/240 for live loads and L/180 for total loads

³ Roof dead load = 12 psf (0.58 kN/m²)

⁴ The minimum *yield strength*, F_y , of *cold-formed steel* framing members is 50 ksi (340 MPa) for members with a *designation thickness* equal to or greater than 54 mils.

Table F3-2
Conversion of Basic Wind Speed to Equivalent Snow Load ^{1,2}

Basic Wind Speed And Exposure		Equivalent Ground Snow Load (psf)									
		Roof Slope									
Exposure	Wind Speed	3:12	4:12	5:12	6:12	7:12	8:12	9:12	10:12	11:12	12:12
B	115 mph	20	20	20	20	30	20	30	30	30	50
	120 mph	20	20	20	20	30	30	30	30	30	50
	130 mph	20	20	20	20	30	30	30	50	50	50
	140 mph	20	20	20	20	30	50	50	50	50	50
	150 mph	30	30	30	50	50	50	70	70	70	-
	160 mph	30	50	50	50	70	70	70	-	-	-
	170 mph	50	50	50	70	70	70	-	-	-	-
	180 mph	50	50	70	70	70	-	-	-	-	-
C	115 mph	20	20	20	20	30	30	30	50	50	50
	120 mph	20	20	20	20	30	30	50	50	50	50
	130 mph	20	20	20	30	30	50	50	50	50	70
	140 mph	30	30	30	50	50	50	70	70	70	-
	150 mph	30	50	50	50	70	70	70	-	-	-
	160 mph	50	50	50	70	70	-	-	-	-	-
	170 mph	50	50	70	70	-	-	-	-	-	-
	180 mph	50	70	70	-	-	-	-	-	-	-

For SI: 1 mph = 1.61 km/hr, 1 psf = 0.0479 kN/m²

¹ In areas where the *basic wind speed* equals or exceeds 120 mph (193 km/h), the equivalent snow load is to be used only to determine the size of members.

² Connections of *roof rafters* to the *ridge* and the roof members to walls are to comply with Section F3.4 and Section F7.

Table F3-3
Screws Required at Each Leg of Clip Angle
for Hip Rafter to Hip Member or Roof Rafter to Ridge Member Connection ¹

Building Width (feet)	Number of Screws			
	Ground Snow Load (psf)			
	0 to 20	21 to 30	31 to 50	51 to 70
24	2	2	3	4
28	2	3	4	5
32	2	3	4	5
36	3	3	5	6
40	3	4	5	7

For SI: 1 foot = 0.305 m, 1 psf = 0.0479 kN/m²

¹ Screws are minimum No. 10.

Table F4-1
Hip Member Sizes ²

Building Width (feet)	Hip Member Designation ¹			
	Equivalent Ground Snow Load (psf)			
	0 to 20	21 to 30	31 to 50	51 to 70
24	800S162-68 800T150-68	800S162-68 800T150-68	800S162-97 800T150-97	1000S162-97 1000T150-97
28	1000S162-68 1000T150-68	1000S162-68 1000T150-68	1000S162-97 1000T150-97	1200S162-97 1200T150-97
32	1000S162-97 1000T150-97	1000S162-97 1000T150-97	1200S162-97 1200T150-97	-
36	1200S162-97 1200T150-97	-	-	-
40	-	-	-	-

For SI: 1 foot = 0.305 m, 1 mil = 0.0254 mm, 1 psf = 0.0479 kN/m²

¹ It is generally desirable that the web depth of the roof rafters and jack rafters match the hip member selected.

² The minimum yield strength, F_y , of cold-formed steel framing members is 50 ksi (340 MPa) for members with a designation thickness equal to or greater than 54 mils.

Table F4-2
Hip Support Column Sizes ²

Building Width (feet)	Hip Support Column Designation ^{1,2}			
	Equivalent Ground Snow Load (psf)			
	0 to 20	21 to 30	31 to 50	51 to 70
24	2-350S162-33	2-350S162-33	2-350S162-43	2-350S162-54
28	2-350S162-54	2-550S162-54	2-550S162-68	2-550S162-68
32	2-550S162-68	2-550S162-68	2-550S162-97	-
36	2-550S162-97	-	-	-
40	-	-	-	-

For SI: 1 foot = 0.305 m, 1 mil = 0.0254 mm, 1 psf = 0.0479 kN/m²

¹ Box shape column only. Refer to Figure F4-2.

² The minimum yield strength, F_y , of cold-formed steel framing members is 50 ksi (340 MPa) for members with a designation thickness equal to or greater than 54 mils.

**Table F4-3
Uplift Strap Connection Requirements
Hip Support Column at Ceiling Line**

Basic Wind Speed (mph)										
Exposure B	115	120	130	140	150	160	170	180		
Exposure C			115	120	130	140	150	160	170	180
Building Width (feet)	Number of No. 10 Screws in Each End of Each 3-inch x 54-mil Steel Strap ^{1, 2, 3}									
	24	3	3	5	5	6	7	8	9	11
28	4	4	7	7	9	10	12	13	15	17
32	6	7	9	10	11	13	15	17	20	22
36	8	9	11	12	15	17	20	22	25	28
40	-	-	-	-	-	-	-	-	-	-

For SI: 1 foot = 0.305 m, 1 psf = 0.0479 kN/m²

¹ Two straps are required, one on each side of the column.

² Space screws at $\frac{3}{4}$ " on center and provide a minimum of $\frac{3}{4}$ " end distance.

³ F_y = 50 ksi for the strap.

**Table F4-4
Connection Requirements
Hip Member to Hip Support Column**

Building Width (feet)	Number of No. 10 Screws in Each Framing Angle ^{1, 2, 3}			
	Equivalent Ground Snow Load (psf)			
	0 to 20	21 to 30	31 to 50	51 to 70
24	10	10	10	12
28	10	10	14	18
32	10	12		-
36	14	-	-	-
40	-	-	-	-

For SI: 1 foot = 0.305 m, 1 psf = 0.0479 kN/m²

¹ Screws are to be divided equally between the connection to the hip member and the column. Refer to Figures F4-3 and F4-4.

² The number of screws required in each framing angle is not to be less than shown in Table F4-3.

³ F_y = 50 ksi for the framing angle.

Table F4-5
Uplift Strap Connection Requirements
Hip Member to Wall

Basic Wind Speed (mph)										
Exposure B	115	120	130	140	150	160	170	180		
Exposure C			115	120	130	140	150	160	170	180
Building Width (feet)	Number of No. 10 Screws in Each End of 1-1/2" x 54-mil Steel Strap ^{1, 2, 3, 4}									
24	2	3	3	3	4	4	5	5	6	7
28	2	4	4	4	5	5	6	7	8	9
32	3	4	5	5	6	7	8	9	10	12
36	4	5	6	6	7	9	10	11	13	15
40	-	-	-	-	-	-	-	-	-	-

For SI: 1 foot = 0.305 m, 1 psf = 0.0479 kN/m²

- ¹ Connections in the unshaded area require a single strap located on either side of the hip member.
- ² Connections in the shaded area require two straps with half the number of screws shown in each end of the strap.
- ³ Space screws at 3/4" on center and provide a minimum of 3/4" end distance.
- ⁴ F_y = 50 ksi for the strap.

Table F5-1
Built-Up Header Size for Six-Foot Roof Opening ^{1,2,3}

Member Designation	Ground Snow Load (psf)			
	20		30	
	Rafter Spacing (inches)			
	16	24	16	24
1000S162-43	1000S162-43	1000S162-43	1000S162-43	1000S162-43
1000S162-54	1000S162-54	1000S162-54	1000S162-54	1000S162-54
1000S162-68	1000S162-54	1000S162-54	1000S162-54	1000S162-54
1000S162-97	1000S162-54	1000S162-54	1000S162-54	1000S162-54
1200S162-54	1200S162-54	1200S162-54	1200S162-54	1200S162-54
1200S162-68	1200S162-54	1200S162-54	1200S162-54	1200S162-54
1200S162-97	1200S162-54	1200S162-54	1200S162-54	1200S162-54

For SI: 1 inch = 25.4 mm, 1 mil = 0.0254 mm, 1 psf = 0.0479 kN/m², 1 foot = 0.305 m.

¹ Deflection criteria: L/240 for live loads, L/180 for total loads.

² Roof dead load = 12 psf (0.575 kN/m²)

³ The minimum yield strength, F_y, of cold-formed steel framing members is 50 ksi (340 MPa) for members with a designation thickness equal to or greater than 54 mils.

Table F5-2
Built-Up Header Size for Six-Foot Roof Opening ^{1,2,3}

Member Designation	Ground snow load (psf)			
	50		70	
	Rafter Spacing (inches)			
	16	24	16	24
1000S162-43	1000S162-43	1000S162-43	1000S162-43	1000S162-43
1000S162-54	1000S162-54	1000S162-54	1000S162-54	1000S162-54
1000S162-68	1000S162-54	1000S162-54	1000S162-54	1000S162-54
1000S162-97	1000S162-54	1000S162-54	1000S162-54	1000S162-54
1200S162-54	1200S162-54	1200S162-54	1200S162-54	1200S162-54
1200S162-68	1200S162-54	1200S162-54	1200S162-54	1200S162-54
1200S162-97	1200S162-54	1200S162-54	1200S162-68	1200S162-54

For SI: 1 inch = 25.4 mm, 1 mil = 0.0254 mm, 1 psf = 0.0479 kN/m², 1 foot = 0.305 m.

¹ Deflection criteria: L/240 for live loads, L/180 for total loads.

² Roof dead load = 12 psf (0.575 kN/m²)

³ The minimum yield strength, F_y , of cold-formed steel framing members is 50 ksi (340 MPa) for members with a designation thickness equal to or greater than 54 mils.

Table F5-3
Built-Up Header Size for Eight-Foot Roof Opening ^{1,2,3}

Member Designation	Ground Snow Load (psf)			
	20		30	
	Rafter Spacing (inches)			
	16	24	16	24
1000S162-43	1000S162-43	1000S162-43	1000S162-43	1000S162-43
1000S162-54	1000S162-54	1000S162-54	1000S162-54	1000S162-54
1000S162-68	1000S162-54	1000S162-54	1000S162-54	1000S162-54
1000S162-97	1000S162-54	1000S162-54	1000S162-54	1000S162-54
1200S162-54	1200S162-54	1200S162-54	1200S162-54	1200S162-54
1200S162-68	1200S162-54	1200S162-54	1200S162-54	1200S162-54
1200S162-97	1200S162-54	1200S162-54	1200S162-54	1200S162-54

For SI: 1 inch = 25.4 mm, 1 psf = 0.0479 kN/m², 1 foot = 0.305 m

¹ Deflection criteria: L/240 for live loads, L/180 for total loads

² Roof dead load = 12 psf (0.575 kN/m²)

³ The minimum yield strength, F_y , of cold-formed steel framing members is 50 ksi (340 MPa) for members with a designation thickness equal to or greater than 54 mils.

Table F5-4
Built-Up Header Size for 8-Foot Roof Opening^{1,2,3}

Member Designation	Ground snow load (psf)			
	50		70	
	Rafter Spacing (inches)			
	16	24	16	24
1000S162-43	1000S162-43	1000S162-43	1000S162-43	1000S162-43
1000S162-54	1000S162-54	1000S162-54	1000S162-54	1000S162-54
1000S162-68	1000S162-54	1000S162-54	1000S162-54	1000S162-54
1000S162-97	1000S162-54	1000S162-54	1000S162-54	1000S162-54
1200S162-54	1200S162-54	1200S162-54	1200S162-54	1200S162-54
1200S162-68	1200S162-68	1200S162-54	1200S162-68	1200S162-54
1200S162-97	1200S162-68	1200S162-68	1200S162-68	1200S162-68

For SI: 1 inch = 25.4 mm, 1 mil = 0.0254 mm, 1 psf = 0.0479 kN/m², 1 foot = 0.305 m

¹ Deflection criteria: L/240 for live loads, L/180 for total loads

² Roof dead load = 12 psf (0.575 kN/m²)

³ The minimum yield strength, F_y , of cold-formed steel framing members is 50 ksi (340 MPa) for members with a designation thickness equal to or greater than 54 mils.

Table F5-5
Built-Up Header Size for Six- or Eight-Foot Ceiling Openings^{1,2,3,4}

Member Designation	Live Load (psf)			
	10		20	
	Ceiling Joist Spacing (inches)			
	16	24	16	24
1000S162-54	1000S162-43	1000S162-43	1000S162-43	1000S162-43
1000S162-68	1000S162-43	1000S162-43	1000S162-43	1000S162-43
1000S162-97	1000S162-43	1000S162-43	1000S162-43	1000S162-43
1200S162-68	1200S162-54	1200S162-54	1200S162-54	1200S162-54
1200S162-97	1200S162-54	1200S162-54	1200S162-54	1200S162-54

For SI: 1 inch = 25.4 mm, 1 mil = 0.0254 mm, 1 psf = 0.0479 kN/m², 1 foot = 0.305 m

¹ Deflection criteria: L/240 for total loads

² Ceiling dead load = 5 psf (0.240 kN/m²)

³ This table applies to all joist bracing conditions of the top (compression) flange.

⁴ The minimum yield strength, F_y , of cold-formed steel framing members is 50 ksi (340 MPa) for members with a designation thickness equal to or greater than 54 mils.

Table F7-1
Required Lengths for Ceiling Diaphragms at Gable Endwalls
Gypsum Board Sheathed
Ceiling Height = 8 ft^{1,2,3,4,5,6}

		Basic Wind Speed (mph)									
Exposure B		115	120	130	140	150	160	170	180		
Exposure C				115	120	130	140	150	160	170	180
Roof Pitch	Building Endwall Width (ft)	Minimum Diaphragm Length (ft)									
3:12 to 6:12	24 - 28	16	18	24	26	30	34	38	42	46	52
	28 - 32	20	20	26	32	34	40	44	50	56	64
	32 - 36	24	26	30	36	42	46	52	60	66	72
	36 - 40	26	28	36	40	48	52	60	68	76	86
6:12 to 9:12	24 - 28	20	20	26	30	34	38	44	48	54	60
	28 - 32	24	26	30	36	42	46	52	58	66	72
	32 - 36	26	30	38	42	48	54	62	70	78	88
	36 - 40	30	34	40	50	56	62	72	80	90	100
9:12 to 12:12	24 - 28	22	24	30	34	38	44	48	56	62	70
	28 - 32	26	28	36	40	46	52	60	68	74	84
	32 - 36	30	32	40	48	54	62	70	80	90	100
	36 - 40	36	38	48	56	64	72	82	92	104	116

For SI: 1 inch = 25.4 mm, 1 mil = 0.0254 mm, 1 psf = 0.0479 kN/m², 1 mph = 1.61 km/hr, 1 foot = 0.305 m

¹ Ceiling *diaphragm* is composed of 1/2-in. gypsum board (min. thickness) secured with screws spaced at 6 in. o.c. at panel edges and 12 in. o.c. in field. Use No. 8 screws (min.) when framing members have a *designation thickness* of 54 mils or less and No. 10 screws (min.) when framing members have a *designation thickness* greater than 54 mils.

² Maximum aspect ratio (length/width) of *diaphragms* is 2:1.

³ Building width is in the direction of horizontal framing members supported by the wall *studs*.

⁴ Required *diaphragm* lengths are to be provided at each end of the structure.

⁵ Required *diaphragm* lengths are permitted to be multiplied by 0.35 if all panel edges are blocked.

⁶ Required *diaphragm* lengths are permitted to be multiplied by 0.9 if all panel edges are secured with screws spaced at 4 in. o.c.

Table F7-2
Required Lengths for Ceiling Diaphragms at Gable Endwalls
Gypsum Board Sheathed
Ceiling Height = 9 or 10 ft ^{1,2,3,4,5,6}

		Basic Wind Speed (mph)									
Exposure B		115	120	130	140	150	160	170	180		
Exposure C				115	120	130	140	150	160	170	180
Roof Pitch	Building Endwall Width (ft)	Minimum Diaphragm Length (ft)									
3:12 to 6:12	24 - 28	18	20	26	30	34	40	44	50	56	62
	28 - 32	24	26	30	36	42	46	52	58	66	72
	32 - 36	26	28	36	40	48	52	60	68	76	86
	36 - 40	30	32	42	48	54	60	70	80	88	98
6:12 to 9:12	24 - 28	22	24	30	34	40	44	50	56	64	70
	28 - 32	26	28	36	40	46	52	60	68	74	84
	32 - 36	30	32	42	48	54	60	70	80	88	98
	36 - 40	36	36	48	54	62	70	80	90	102	114
9:12 to 12:12	24 - 28	24	26	32	38	44	48	56	62	68	78
	28 - 32	28	32	40	46	52	58	66	76	84	94
	32 - 36	32	36	46	54	60	68	78	88	98	110
	36 - 40	40	44	54	60	70	80	92	102	114	128

For SI: 1 inch = 25.4 mm, 1 psf = 0.0479 kN/m², 1 mph = 1.61 km/hr, 1 foot = 0.305 m

¹ Ceiling *diaphragm* is composed of 1/2-in. gypsum board (min. thickness) secured with screws spaced at 6 in. o.c. at panel edges and 12 in. o.c. in field. Use No. 8 screws (min.) when framing members have a *designation thickness* of 54 mils or less and No. 10 screws (min.) when framing members have a *designation thickness* greater than 54 mils.

² Maximum aspect ratio (length/width) of *diaphragms* is 2:1.

³ Building width is in the direction of horizontal framing members supported by the wall *studs*.

⁴ Required *diaphragm* lengths are to be provided at each end of the structure.

⁵ Required *diaphragm* lengths are permitted to be multiplied by 0.35 if all panel edges are blocked.

⁶ Required *diaphragm* lengths are permitted to be multiplied by 0.9 if all panel edges are secured with screws spaced at 4 in. o.c.

Table F7-3
Required Lengths for Ceiling Diaphragms at Gable Endwalls
Wood Structural Panel Sheathed
Ceiling Height = 8 ft ^{1,2,3,4}

		Basic Wind Speed (mph)									
Exposure B		115	120	130	140	150	160	170	180		
Exposure C				115	120	130	140	150	160	170	180
Roof Pitch	Building Endwall Width (ft)	Minimum Diaphragm Length (ft)									
3:12 to 6:12	24 - 28	10	10	10	10	10	10	10	10	10	10
	28 - 32	12	12	12	12	12	12	12	12	12	12
	32 - 36	12	12	12	12	12	12	12	12	12	12
	36 - 40	14	14	14	14	14	14	14	14	14	14
6:12 to 9:12	24 - 28	10	10	10	10	10	10	10	10	10	10
	28 - 32	12	12	12	12	12	12	12	12	12	12
	32 - 36	12	12	12	12	12	12	12	12	14	14
	36 - 40	14	14	14	14	14	14	14	14	16	16
9:12 to 12:12	24 - 28	10	10	10	10	10	10	10	10	10	12
	28 - 32	12	12	12	12	12	12	12	12	12	14
	32 - 36	12	12	12	12	12	12	12	14	16	18
	36 - 40	14	14	14	14	14	14	14	16	18	18

For SI: 1 inch = 25.4 mm, 1 mil = 0.0254 mm, 1 psf = 0.0479 kN/m², 1 mph = 1.61 km/hr, 1 foot = 0.305 m

¹ Ceiling *diaphragm* is composed of 3/8" wood structural panel sheathing (min. thickness) secured with screws spaced at 6" o.c. at panel edges and in field. Use No. 8 screws (min.) when framing members have a *designation thickness* of 54 mils or less and No. 10 screws (min.) when framing members have a *designation thickness* greater than 54 mils.

² Maximum aspect ratio (length/width) of *diaphragms* is 3:1.

³ Building width is in the direction of horizontal framing members supported by the wall *studs*.

⁴ Required *diaphragm* lengths are to be provided at each end of the structure.

Table F7-4
Required Lengths for Ceiling Diaphragms at Gable Endwalls
Wood Structural Panel Sheathed
Ceiling Height = 9 or 10 ft^{1,2,3,4}

		Basic Wind Speed (mph)									
Exposure B		115	120	130	140	150	160	170	180		
Exposure C				115	120	130	140	150	160	170	180
Roof Pitch	Building Endwall Width (ft)	Minimum Diaphragm Length (ft)									
3:12 to 6:12	24 - 28	10	10	10	10	10	10	10	10	10	12
	28 - 32	12	12	12	12	12	12	12	12	12	12
	32 - 36	12	12	12	12	12	12	12	12	12	14
	36 - 40	14	14	14	14	14	14	14	14	14	16
6:12 to 9:12	24 - 28	10	10	10	10	10	10	10	10	10	12
	28 - 32	12	12	12	12	12	12	12	12	12	14
	32 - 36	12	12	12	12	12	12	12	12	12	16
	36 - 40	14	14	14	14	14	14	14	14	14	18
9:12 to 12:12	24 - 28	10	10	10	10	10	10	10	10	10	14
	28 - 32	12	12	12	12	12	12	12	12	12	16
	32 - 36	12	12	12	12	12	12	12	12	14	18
	36 - 40	14	14	14	14	14	14	14	14	16	20

For SI: 1 inch = 25.4 mm, 1 mil = 0.0254 mm, 1 psf = 0.0479 kN/m², 1 mph = 1.61 km/hr, 1 foot = 0.305 m

¹ Ceiling *diaphragm* is composed of 3/8" wood structural panel sheathing (min. thickness) secured with screws spaced at 6" o.c. at panel edges and in field. Use No. 8 screws (min.) when framing members have a *designation thickness* of 54 mils or less and No. 10 screws (min.) when framing members have a *designation thickness* greater than 54 mils.

² Maximum aspect ratio (length/width) of *diaphragms* is 3:1.

³ Building width is in the direction of horizontal framing members supported by the wall *studs*.

⁴ Required *diaphragm* lengths are to be provided at each end of the structure.

**Table F8-1
Required Uplift Strength
Roof Rafter or Roof Truss to Wall**

		Basic Wind Speed (mph)				
EXPOSURE B		160	170	180		
EXPOSURE C		140	150	160	170	180
Framing Spacing ³ (in.)	Roof Span (ft)	Required Connection Strength ^{1,2} (lbs)				
12	24	270	323	381	442	507
	28	302	363	428	497	571
	32	335	403	475	552	634
	36	367	442	522	607	698
	40	400	482	569	662	761
16	24	359	431	508	590	677
	28	403	484	571	663	761
	32	446	537	633	736	845
	36	490	590	696	810	930
	40	534	643	759	883	1020
19.2	24	431	517	610	708	812
	28	483	581	685	796	913
	32	536	644	760	883	1010
	36	588	708	835	972	1120
	40	640	771	911	1060	1220
24	24	539	647	762	885	1020
	28	604	726	856	994	1140
	32	669	805	950	1100	1270
	36	735	884	1040	1220	1400
	40	800	964	1140	1330	1520

For SI: 1 inch = 25.4 mm, 1 foot = 0.305 m, 1 lb = 4.45 N, 1 mph = 1.61 km/hr

¹ Uplift requirements assume a roof/ceiling dead load of 12 psf (0.58 kN/m²).

² Required connection strengths are nominal values to be used with published strengths expressed as allowable loads.

³ The 12-inch (305-mm) and 19.2-inch (488-mm) framing spacing provide options for design, but do not negate the in-line framing requirement of Chapter E.

Table F8-2
Uplift Strap Connection Requirements
Roof Rafter or Roof Truss to Wall

		Basic Wind Speed (mph)				
EXPOSURE B		160	170	180		
EXPOSURE C		140	150	160	170	180
Framing Spacing ¹ (in.)	Roof Span (ft)	Number of No. 8 Screws in Each End of Steel Uplift Strap				
12	24	2	2	3	3	4
	28	2	3	3	4	4
	32	3	3	3	4	4
	36	3	3	4	4	5
	40	3	3	4	5	5
16	24	3	3	4	4	5
	28	3	3	4	5	5
	32	3	4	4	5	6
	36	3	4	5	5	6
	40	4	4	5	6	7
19.2	24	3	4	4	5	5
	28	3	4	5	5	6
	32	4	4	5	6	7
	36	4	5	6	6	7
	40	4	5	6	7	8
24	24	4	4	5	6	7
	28	4	5	6	7	7
	32	5	5	6	7	8
	36	5	6	7	8	9
	40	5	6	7	9	10

For SI: 1 inch = 25.4 mm, 1 foot = 0.305 m, 1 mph = 1.61 km/hr

¹ The 12-inch (305-mm) and 19.2-inch (488-mm) framing spacing provide options for design, but do not negate the *in-line framing* requirement of Chapter E.

Table F8-3
Ridge Tension Strap Connection Requirements per Foot of Ridge Span ³

		Basic Wind Speed (mph)					Basic Wind Speed (mph)				
EXPOSURE B		160	170	180			160	170	180		
EXPOSURE C		140	150	160	170	180	140	150	160	170	180
Roof Pitch	Roof Span (ft)	Number of No. 8 Screws in Each End of a Steel Ridge Strap ²					Required Ridge Connection Strength ¹ (plf)				
3:12	24	4	5	6	6	7	620	744	870	977	1098
	28	5	6	7	7	8	716	859	1007	1130	1270
	32	6	7	8	8	9	831	992	1165	1308	1469
	36	6	7	8	9	11	936	1126	1312	1474	1655
	40	7	8	9	10	12	1041	1252	1459	1639	1841
4:12	24	3	4	5	5	6	494	594	691	776	871
	28	4	5	6	6	7	573	689	802	901	1012
	32	4	5	6	7	8	660	790	923	1037	1165
	36	5	6	7	8	9	743	890	1040	1168	1312
	40	6	7	8	8	9	826	989	1156	1298	1458
5:12	24	3	3	4	4	5	387	465	542	608	683
	28	3	4	4	5	5	449	540	630	707	795
	32	4	4	5	5	6	516	620	723	812	912
	36	4	5	5	6	7	581	697	815	915	1029
	40	4	5	6	7	8	646	777	905	1017	1142
6:12	24	3	3	3	4	4	342	412	480	539	605
	28	3	3	4	4	5	398	478	558	627	704
	32	3	4	4	5	5	457	549	639	719	806
	36	4	4	5	5	6	514	618	720	809	908
	40	4	5	5	6	7	571	686	799	897	1008
7:12	24	2	3	3	4	4	313	376	439	493	554
	28	3	3	4	4	4	365	438	511	574	644
	32	3	4	4	5	5	418	503	585	657	738
	36	3	4	5	5	6	471	565	659	741	832
	40	4	4	5	6	6	523	629	732	822	923
8:12-12:12	24	2	3	3	4	4	294	353	412	463	520
	28	3	3	3	4	4	342	412	480	539	605
	32	3	3	4	4	5	393	472	550	618	694
	36	3	4	4	5	5	441	530	618	695	780
	40	3	4	5	5	6	491	590	688	773	868

For SI: 1 inch = 25.4 mm, 1 foot = 0.305 m, 1 lb = 4.45 N, 1 mph = 1.61 km/hr

¹ Connection requirements are based on a roof assembly dead load of 7 psf (0.34 kN/m²).

² Connection strengths shown in Table F8-3 are based on a 12-in. (305 mm) *ridge strap* spacing. For spacing greater than 12 inches (305 mm), strength values are to be increased using the multipliers in Table F8-4.

³ The required number of screws shown in Table F8-3 is based on a 12-in. (305 mm) *strap* spacing. For spacing other than 12 in. (305 mm), the appropriate connection strength in the table is to be increased using the multipliers in Table F8-4 and dividing by the screw shear value of 165 lb/screw. Screw substitutions factors from Table B1-1 can be used for screws larger than No. 8.

Table F8-4
Framing Spacing Multiplier for Use With Table F8-3

Framing Spacing ¹	12 in.	16 in.	19.2 in.	24 in.
Multiplier	1.00	1.33	1.60	2.00

For SI: 1 inch = 25.4 mm

Table F8-5
Minimum Size of Steel Uplift Strap or Ridge Strap ²

Strap Width (in.)	Minimum Thickness of Strap (mils)									
	Required Number of Screws ¹									
	4 OR LESS	5	6	7	8	9	10	11	12	13
1.25	33	43	54	54	68	68	97	97	97	97
1.50	33	43	43	54	54	68	68	97	97	97
1.75	33	33	33	43	54	54	54	68	68	97
2.00	33	33	33	43	43	54	54	68	68	68

For SI: 1 inch = 25.4 mm, 1 mil = 0.0254 mm

¹ Required number of screws per Table F8-2 or F8-3 in each end of the steel uplift strap or ridge strap.

² The minimum yield strength, F_y , of cold-formed steel framing members is 50 ksi (340 MPa) for members with a designation thickness equal to or greater than 54 mils.



AISI STANDARD

Commentary on the Standard for Cold-Formed Steel Framing— Prescriptive Method for One- and Two-Family Dwellings

2015 Edition

Revision of:
AISI S230-07-C With Supplements 2 and 3
(Reaffirmed 2012)

DISCLAIMER

The material contained herein has been developed by the American Iron and Steel Institute (AISI) Committee on Framing Standards. The Committee has made a diligent effort to present accurate, reliable, and useful information on cold-formed steel framing design and installation. The Committee acknowledges and is grateful for the contributions of the numerous researchers, engineers, and others who have contributed to the body of knowledge on the subject. Specific references are included in this *Commentary*.

With anticipated improvements in understanding of the behavior of cold-formed steel framing and the continuing development of new technology, this material will become dated. It is anticipated that AISI will publish updates of this material as new information becomes available, but this cannot be guaranteed.

The materials set forth herein are for general purposes only. They are not a substitute for competent professional advice. Application of this information to a specific project should be reviewed by a *registered design professional*. Indeed, in many jurisdictions, such review is required by law. Anyone making use of the information set forth herein does so at their own risk and assumes any and all liability arising therefrom.

The user is advised to check the availability of specific framing material in the region in which the dwelling is being constructed.

1st Printing – November 2015

Produced by American Iron and Steel Institute

Copyright American Iron and Steel Institute 2015

PREFACE

The American Iron and Steel Institute (AISI) Committee on Framing Standards (COFS) has developed this *Commentary on the Standard for Cold-Formed Steel Framing – Prescriptive Method for One- and Two-Family Dwellings (Commentary)* to provide the background, supplemental information, engineering assumptions and methods, and detailed calculations for the provisions of AISI S230 (AISI, 2015a).

The loads, load combinations, and other design parameters used to develop the provisions in AISI S230 were based on the *International Residential Code* (ICC, 2015b), the *International Building Code* (ICC, 2015a) (where no provisions are included in the *International Residential Code*) and ASCE 7-10, *Minimum Design Loads for Buildings and Other Structures* (ASCE, 2010).

The *Commentary* is provided only for those sections of AISI S230 where background or supplemental information is of benefit to the user. Sections thought to need no explanation are left blank.

This document contains the background, supplemental information and engineering assumptions. In previous editions of the *Commentary*, Section 2, Design Examples, contained detailed calculations that demonstrated how the values in the AISI S230 were derived. These examples no longer apply with the update of the Standard to ASCE 7-10 using ultimate values for wind.

Terms within the body of this *Commentary* that are shown in *italics* indicate that the italicized word is a defined term by AISI S230 or AISI S240 (AISI, 2015b).

The Committee acknowledges and is grateful for the contributions of the numerous engineers, researchers, producers and others who have contributed to the body of knowledge on the subjects.

This Page is Intentionally Left Blank.

**COMMENTARY ON THE
STANDARD FOR COLD-FORMED STEEL FRAMING —
PRESCRIPTIVE METHOD FOR ONE- AND TWO-FAMILY DWELLINGS**

Disclaimer	ii
Preface	iii
COMMENTARY ON THE STANDARD FOR COLD-FORMED STEEL FRAMING— PRESCRIPTIVE METHOD FOR ONE AND TWO FAMILY DWELLINGS	1
A. GENERAL	1
A1 Scope.....	1
A1.1 Limits of Applicability	1
A1.2 Limitations in High Seismic and High Wind Areas	2
A1.2.1 Irregular Buildings in High Seismic and High Wind Areas	2
A2 Definitions	2
A3 Referenced Documents	2
A4 Limitations of Framing Members.....	3
A4.1 General	3
A4.2 Sheathing Span Capacity.....	3
A4.4 Material Properties	4
A4.4.1 Material Properties in High Wind and High Seismic Areas.....	4
A4.5 Web Holes.....	5
A4.6 Hole Reinforcing.....	5
A4.7 Hole Patching.....	5
B. CONNECTIONS.....	6
B1 Fastening Requirements	6
B2 Bearing Stiffeners.....	6
B3 Clip Angles	6
B4 Anchor Bolts	6
D. FLOOR FRAMING.....	7
D1 Floor Construction.....	7
D2 Floor to Foundation or Structural Wall Connection.....	7
D3 Minimum Floor Joist Sizes	7
D3.1 Floor Cantilevers	8
D4 Bearing Stiffeners.....	8
D5 Joist Bracing and Blocking.....	8
D5.1 Joist Top Flange Bracing.....	8
D5.2 Joist Bottom Flange Bracing/Blocking	8
D5.3 Blocking at Interior Bearing Supports	8
D5.4 Blocking at Cantilevers	8
D6 Splicing.....	9
D7 Framing of Floor Openings	9
D8 Floor Trusses	9
D9 Diaphragms	9
D9.1 Floor Diaphragms in High Seismic and High Wind Areas	9
E. WALL FRAMING.....	11
E2 Wall to Foundation or Floor Connection	11
E3 Minimum Stud Sizes	11
E4 Stud Bracing	12

E5	Splicing.....	12
E6	Corner Framing.....	13
E7	Headers.....	13
E7.1	Box Headers	13
E7.2	Back-to-Back Headers	13
E7.3	L-Headers	14
E7.3.1	Double L-Headers.....	14
E7.3.2	Single L-Headers.....	14
E7.3.3	Inverted L-Headers.....	14
E7.4	Jack and King Studs	15
E7.5	Head and Sill Track.....	15
E8	Wall Bracing	15
E8.1	Strap Bracing (X-brace).....	15
E8.2	Structural Sheathing.....	16
E9	Exterior Wall Covering.....	17
E11	Braced Walls in High Wind Areas and High Seismic Areas	17
E11.1	General.....	17
E11.2	Braced Wall Lines.....	19
E11.3	Type I (Solid Sheathed) Braced Wall Panels.....	19
E11.4	Type II (Perforated) Braced Wall Lines.....	19
E12	Braced Wall Design in High Seismic Areas	19
E12.2	Braced Wall Anchorage and Chord Stud Requirements.....	19
E13	Braced Wall Design in High Wind Areas.....	20
E13.3	Connections of Walls in High Wind Areas.....	20
E13.3.2	Uplift Connection - Wall Assembly to Wall Assembly.....	20
E13.3.3	Header Uplift Connections.....	20
F.	ROOF FRAMING.....	21
F1	Roof Construction.....	21
F2	Ceiling Joists.....	21
F2.1	Minimum Ceiling Joist Size	21
F2.2	Ceiling Joist Bearing Stiffeners	21
F2.3	Ceiling Joist Bottom Flange Bracing	21
F2.4	Ceiling Joist Top Flange Bracing	21
F2.5	Ceiling Joist Splicing	21
F3	Roof Rafters	22
F3.1	Minimum Roof Rafter Sizes	22
F3.1.1	Eave Overhang	22
F3.1.2	Rake Overhang.....	22
F3.2	Roof Rafter Support Brace.....	22
F3.3	Roof Rafter Splice	22
F3.5	Roof Rafter Bottom Flange Bracing.....	22
F4	Hip Framing	23
F5	Framing of Openings in Roofs and Ceilings.....	23
F6	Roof Trusses	23
F7	Ceiling and Roof Diaphragms	23
	REFERENCES.....	24

COMMENTARY ON THE STANDARD FOR COLD-FORMED STEEL FRAMING— PRESCRIPTIVE METHOD FOR ONE- AND TWO-FAMILY DWELLINGS

A. GENERAL

A1 Scope

AISI S230 (AISI, 2015a) consists of prescriptive requirements for *cold-formed steel* floor, wall, and roof framing to be used in the construction of one- and two-family dwellings, townhouses, and other attached and detached single-family dwellings not more than three stories in height using *repetitive in-line framing* practices.

A1.1 Limits of Applicability

AISI S230 is not applicable to all possible conditions of use and is subject to the applicability limits set forth in Section A1.1 and A1.2. The applicability limits are necessary to define reasonable boundaries to the conditions that must be considered in developing prescriptive construction requirements. The applicability limits should be carefully understood as they define important constraints on the use of AISI S230.

The applicability limits strike a reasonable balance between engineering theory, available test data, and proven field practices for typical residential construction applications. The applicability limits are intended to prevent misapplication while addressing a reasonably large percentage of new housing conditions. Special consideration is directed toward the following items related to the applicability limits.

Building Geometry: The provisions in AISI S230 apply to detached one- and two-family dwellings, townhouses, and other attached single-family dwellings not more than three stories in height. Its application to homes with complex architectural configurations is subject to careful interpretation by the user and therefore, engineering design support may be required. The most common building widths (or depths) range from 24 feet to 40 feet (7.3 to 12.2 m), with axially load bearing wall heights up to 10 feet (3.1 m). The building width as used in AISI S230 is the dimension measured along the length of the *joists* (floor or ceiling) between the outmost structural walls. The maximum length of building is limited to 60 feet (18.3 m) where the length is measured in the direction parallel to the roof ridge or perpendicular to the *floor joists* or roof *trusses*. In 2006, the maximum *mean roof height* was explicitly defined as 33 feet (9.14 m) above *average grade*, since this is what was actually used in the development of the Standard.

Site Conditions: Conditions for each site must be established by the user. Local conditions include ground snow loads, *basic wind speeds*, and the *Seismic Design Category*.

Snow Loads: Snow load values are typically given in a ground snow load map such as provided in the building code, ASCE 7 (ASCE, 2010) or by local practice. The national model building codes in the U.S. either adopt the ASCE 7 snow map and load requirements or have a similar map published in the code. The 0 to 70 psf (0 to 3.35 kN/m²) ground snow load used in AISI S230 covers approximately 90 percent of the United States, which was deemed to include the majority of the buildings that are expected to utilize this document. Buildings in areas with greater snow loads than 70 psf (3.35 kN/m²) should not use this document without consulting a *registered design professional*.

Basic Wind Speed: In 2006, in recognition that all areas of the U.S. fall within the 90 to 150

mph (3-second gust) (145 to 241 km/hr) range of design wind speeds per ASCE 7 (ASCE, 2005), the maximum *basic wind speed* in the Standard was increased from 130 mph (209 km/hr) to 150 mph (241 km/hr). Also per ASCE 7, the three-second-gust wind speeds were used in the development of AISI S230. ASCE 7 (ASCE, 2010) enables the determination of wind load by either the directional or envelope method. The directional method was used for the development of AISI S230-15. Wind speed maps were also revised in ASCE 7 (ASCE, 2010) and are directly applicable to determining pressures for strength design. Wind speed and exposure are defined in AISI S230. *Wind exposure category* is a critical determinant of the wind loads to be expected at a given site, and it should be determined by good judgment on a case-by-case basis. The *wind exposure category* in AISI S230 tables is limited to *Wind Exposures B and C*.

In 2015, provisions were added to allow dwellings sited in *Wind Exposure D* to be designed in accordance with the requirements for *Wind Exposure C*, provided that the *basic wind speed* for the *Wind Exposure D* site is adjusted to an equivalent *basic wind speed* for a *Wind Exposure C* site in accordance with Table A1-3. This means, for example, that the provisions of AISI S230 for 150 mph *Wind Exposure C* may be used in cases where *Wind Exposure D* is specified by the *applicable building code* and the *basic wind speed* is not greater than 138 mph.

Seismic Design Category: AISI S230 covers all residential constructions in *Seismic Design Categories A, B, C, D₀, D₁, D₂* and E (within the limits of applicability of Tables A1-1 and A1-2).

Loads: Consistent values were established for design loads in accordance with a review of the major building codes and standards. The results of this load review are embodied in the applicability limits table in AISI S230. Loads and load combinations requiring calculations to analyze the structural components and assemblies of a home are presented in the design examples shown throughout this document. The Load and Resistance Factor Design (LRFD) load combinations as shown in ASCE 7 were used to develop the tables and other provisions in AISI S230.

AISI S230, however, does not limit the application of alternative methods or materials through engineering design.

A1.2 Limitations in High Seismic and High Wind Areas

A1.2.1 Irregular Buildings in High Seismic and High Wind Areas

In *high wind* and *high seismic areas*, additional limitations were considered to be necessary. Plan and vertical offsets are not permitted in this edition of AISI S230 for simplicity. Where the user wishes to exceed the irregularity limits, a *registered design professional* should be consulted.

A2 Definitions

Many of the terms in AISI S230 are self-explanatory. Only definitions of terms not self-explanatory or not defined in the referenced documents are provided in AISI S230 or AISI S240.

A3 Referenced Documents

The design tables contained in previous editions of AISI S230 were generated at different times and, consequently, were based on different editions of AISI S100, *North American Specification for the Design of Cold-Formed Steel Structural Members*. For example, the *floor joist*, *ceiling joist* and screw connection tables were developed using the 1996 edition with the 1999 Supplement; whereas the wall stud, back-to-back *header*, box *header*, L-*header*, roof rafter and

gable end wall tables were developed using the 2001 edition with the 2004 Supplement. The 2012 edition of AISI S100 (AISI, 2012a) was used in the development of the 2015 edition of AISI S230.

A4 Limitations of Framing Members

A4.1 General

The *structural members* used in AISI S230 are standard *C-shapes* produced by roll forming hot-dipped metallic coated sheet steel conforming to AISI S201 (AISI, 2012b).

In 2007, AISI S230 recognized that steel sheet in compliance with the requirements of ASTM A653 Type SS or ASTM A792 Type SS complied with the material specification requirements of the AISI framing standards. In 2010, as part of an exercise to synchronize all relevant codes and specifications, provisions that were considered duplicative of the requirements already in AISI standards were eliminated. However, it should be noted that it is no longer the intention of the Standard that steel sheet in compliance with the requirements of ASTM A653 Type SS or ASTM A792 Type SS be deemed to comply with the material specification requirements of the AISI framing standards, including AISI S230. ASTM A1003 Type H steels are used in the construction of braced walls in high seismic areas.

A4.2 Sheathing Span Capacity

In 2015, limitations for the spacing of structural floor, wall, roof and ceiling members based on the *span capacity* of the *structural sheathing* were included. Prior editions did not address *structural sheathing span* requirements for out-of-plane loading such as live load or snow load. These limitations are the same as those given in AISI S240-15.A4.3, Physical Dimensions.

Member section designations, in accordance with AISI S201 (AISI, 2012b), are used throughout AISI S230. The designation system was developed in 1996 in order to standardize the identification of cold-formed steel framing based on specific shapes and material thickness. The designator consists of four parts: the first value represents the *web* depth, the second value represents the type of steel framing member, the third value represents the *flange* width, and the fourth value represents the minimum base steel thickness.

Web Depth: The actual *web* depths chosen for AISI S230 are 3-1/2 inches, 5-1/2 inches, 8 inches, 10 inches, and 12 inches (89, 140, 203, 254 and 305 mm). The 3-1/2 and 5-1/2 inch (89 and 140 mm) *web* depths were chosen to accommodate current framing dimensions utilized in the residential building industry (i.e., to accommodate window and door jambs). These sizes can be used directly with conventional building materials and practices; however, the substitution of a slightly larger size member, such as using a 3-5/8 inch (92 mm) or 4-inch (102 mm) stud instead of a 3-1/2 inch (89 mm) stud, are acceptable. The depth of the *web* for 8-, 10-, and 12-inch (203, 254, and 305 mm) members, versus traditional lumber sizes, are not of great significance because they are typically used for horizontal framing members (i.e. headers and joists).

Flange Width: AISI S230 requires that the standard *C-shape* have a minimum of 1-5/8 inch (41 mm) *flange* with a maximum *flange* dimension of 2 inches (51 mm).

Lip Size and Corner Radii: AISI S201 provides a minimum size for the stiffening *lip* and the corner radii. These dimensions are common in the industry. Decreasing the *lip* size may have a detrimental effect on the structural capacity of structural members in many circumstances.

AISI S230 requires steel *tracks* to have a minimum *flange* dimension of 1-1/4 inches (32

mm). This dimension ensures a sufficient *flange* width to allow fastening of the *track* to the framing members and finish materials. Steel *track webs* are measured from inside to inside of *flanges* and thus have wider overall *web* depths than the associated standard *C-shapes*. This difference in size allows the *C-shape* to be properly nested into the *track* sections. In AISI S230, *tracks* are always required to have a minimum steel thickness equal to or greater than the *structural members* to which they are attached.

The steel thickness indicated by AISI S230 is the minimum uncoated steel thickness (excluding the thickness of the metallic coating) and is given in mils (1/1000 of an inch). This unit is a deviation from the historic practice, which uses a gauge designation for thickness. The “gauge” is an outdated reference that represents a range of thicknesses and is, therefore, a vague unit of measure when specifying minimums. The practice of using “gauge” as a basis for measurement has been discontinued in the industry. In order to achieve consistency, the *mil* designation was adopted. For example, the 33 mils (i.e., 0.033 inches or 0.84 mm), 43 mils (i.e., 0.043 inches or 1.09 mm), 54 mils (i.e., 0.054 inches or 1.37 mm), 68 mils (i.e., 0.068 inches or 1.73 mm), and 97 mils (i.e., 0.097 inches or 2.46 mm) are specified for the thickness.

The minimum thickness is the minimum delivered thickness that cannot be less than the *design thickness* multiplied by 0.95, which is permitted by the AISI *Specification* (AISI, 2012). The *design thickness* of the flat steel stock, exclusive of coatings, is used in the structural calculations.

The corner bend radius is measured on the inside of bends in cold-formed steel members. Strength increases are realized in the regions of bends due to a phenomenon known as cold working, which locally increases the yield strength of the steel.

A4.4 Material Properties

Prior to 2015, AISI S230 applied to steel with minimum *yield strength* of 33 ksi (230 MPa) or 50 ksi (345 MPa). The 33 ksi (230 MPa) steels are the minimum required for all steel floors, roofs, and *header* components. Multiple-span *floor joist*, wall *stud*, *header* and *roof rafter* tables were provided for both 33 ksi (230 MPa) and 50 ksi (345 MPa) minimum *yield strength*. The 50 ksi (345 MPa) *yield strength* steel was included because of the structural benefits.

In 2015, AISI S230 was streamlined to include tabulated solutions for just the more popular material *yield strengths* for each *designation thickness*: 33 ksi is used for 33 mil and 43 mil thick material, and 50 ksi is used for material equal to or greater than 54 mil thickness.

The user is advised to check the availability of specific framing material in the region in which the dwelling is being constructed. Not all material specified in AISI S230 is expected to be available in all locations.

Strength increase from the cold work of forming (as permitted by the AISI *Specification*) is utilized for the design of *C-shaped* members in AISI S230 used as flexural members, concentrically loaded compression members, and members with combined axial and bending loads. The reader is referred to the *Cold-Formed Steel Design Manual* (AISI, 2013) for engineering calculations illustrating the application of the strength increase due to cold work of forming.

A4.4.1 Material Properties in High Wind and High Seismic Areas

Further limitations on material properties are imposed for the use of AISI S230 in high wind and high seismic areas. These limitations were imposed to reflect the material properties used in the available *shear wall* test data.

A4.5 Web Holes

All *structural members* (i.e., *floor and ceiling joists, wall studs and headers*), except cantilevered portions of framing members, used in AISI S230 are designed assuming maximum web hole dimensions as shown in Figure A4-1 and A4-2 of AISI S230. The maximum web hole dimensions are consistent with AISI S201 (AISI, 2012b). The design procedure follows AISI S100 (AISI, 2012a).

A4.6 Hole Reinforcing

This section provides reinforcing options for web holes violating the requirements of AISI S230 Section A4.5 and is based on engineering judgment and research at McMaster University (Siva, 2007).

A4.7 Hole Patching

In 2004, the limitations “that the depth of the hole does not exceed 70% of the flat width of the *web* and the length of the hole measured along the *web* does not exceed 10 inches (254 mm) or the depth of the *web*, whichever is greater” were added along with other editorial changes to better differentiate the permitted use of a patch versus required member replacement or engineering analysis.

B. CONNECTIONS

B1 Fastening Requirements

Self-drilling screws conforming to the requirements of AISI S240 (AISI, 2015b) are specified as the fastener for cold-formed steel framing members in AISI S230. Requirements for sharp point screws connecting gypsum board and sheathing to steel *studs* are found in ASTM C1002 (ASTM, 2007) and ASTM C954 (ASTM, 2010). The edge distance and center-to-center spacing of these screws follow industry recommendations and AISI S100 (AISI, 2012a). Although AISI S230 specifies the use of screws, other fastening methods are permitted to be used provided that the connection capacity can be shown to equal or exceed the connection capacity implied in AISI S230.

For practical purposes and added capacity in certain applications, No. 10 screws are specified in AISI S230. Because the point style of the screw may affect constructability, screw manufacturer recommendations should be consulted. For example, a sharp point screw may be efficiently used to connect gypsum board and other panel products to steel framing members that are no thicker than 33 mils (0.84 mm).

Screw capacities are calculated based on the design equations given in AISI S100. This equations are used to calculate the shear, pull-over, and pull-out capacities of a connection based on the thickness and tensile strength of the steel, and diameter of the screw.

AISI S230 also provides a screw substitution factor where larger screws can be used in lieu of the No. 8 screws or when one of the sheets of steel being connected is thicker than 33 mils (0.84 mm). This may result in a reduced number of screws.

B2 Bearing Stiffeners

Webs of cold-formed steel members may cripple or buckle locally at locations of a concentrated load or a bearing support. The allowable reactions and concentrated loads for beams having single unreinforced *webs* depend on *web* depth, bend radius, *web* thickness, *yield strength*, and actual bearing length.

The *floor joist spans* in AISI S230 were derived assuming *bearing stiffeners* (also called *web stiffeners*) are located at all support or bearing point locations. *Ceiling joist span* tables were developed for two cases: 1) assuming *bearing stiffeners* are located at all support or bearing point locations, and 2) no *bearing stiffeners*. Where specified, *bearing stiffeners* are to be a minimum of 43 mil (1.09 mm) clip angle or *track* section, or 33 mil (0.84 mm) *C-shaped* member.

Three types of *bearing stiffeners* are permitted in AISI S230: *C-shaped*, *track*, and *clip angle*. The requirements for the *C-shaped* and *track bearing stiffeners* are based on engineering judgment, the *bearing stiffener* connection to the rim *track* is optional, and either screw pattern in Figure B2-1 is permitted. The *clip angle bearing stiffener* requirements are stipulated in AISI S240 (AISI, 2015b).

B3 Clip Angles

All *clip angle* dimensions prescribed are shown as minimums. *Clip angles* that are of a greater *base steel thickness* or have greater overall dimensions, or both, are permitted to be used up to a maximum thickness of 68 mils.

B4 Anchor Bolts

In the *high wind areas* and *high seismic areas*, the requirement for a minimum steel plate washer is based on engineering judgment.

D. FLOOR FRAMING

D1 Floor Construction

Floor *trusses* are not prescriptively addressed in AISI S230 but are permitted, in accordance with Section D8, and must be designed by a *registered design professional*. Floor girders are also not addressed in AISI S230.

D2 Floor to Foundation or Structural Wall Connection

AISI S230 provides several details for connecting floor assemblies to foundations or structural walls. The details reflect common industry practice. In areas where wind speeds exceed 140 mph (177 km/hr) (*Wind Exposure C*) or in *Seismic Design Category D₁, D₂ or E*, additional requirements for hold-downs and anchors are specified in Sections E11, E12 and E13.

D3 Minimum Floor Joist Sizes

AISI S230 provides *floor joist* tables with maximum allowable spans for two live load conditions: 30 psf and 40 psf (1.44 and 1.92 kN/m²). The two live load conditions are specified in the *International Building Code* (ICC, 2015a) and the *International Residential Code* (ICC, 2015b). The 30 psf (1.44 kN/m²) is typically specified for sleeping areas, while the 40 psf (1.92 kN/m²) is specified for living areas. The spans shown in AISI S230 assume *bearing stiffeners* are installed at each bearing point. *Bearing stiffener* requirements are provided in Section B2 of AISI S230.

For the design of *floor joists*, the following design considerations were evaluated:

- Flexural yielding
- Flexural buckling
- Web crippling
- Shear
- Vertical deflection
- Combined bending and shear (for multiple spans only)

All *joists* are considered to have *web* holes (a.k.a. “penetrations,” “utility holes,” and “punchouts”) in accordance with Section A4.5. The compression *flange* (top *flange*) of a *floor joist* is assumed to be continuously braced by the subflooring, thus providing lateral bracing for the top *flanges*.

The *joist span* tables are calculated for a deflection limit of L/480 for live load and L/240 for total loads, where L is the clear horizontal distance between supports. The L/480 limit may be more stringent than the minimum deflection limits established by building codes, but was selected to achieve a satisfactory floor design for serviceability.

Two-span joists are commonly used in the residential steel building market. Certain measures are necessary to address the responses of the loaded members. The magnitude of the reaction at the middle support will be greater than the end reactions. The mid-span reaction and also the end reactions may cause a *web* crippling failure at those locations, and consequently, the *bearing stiffener* at the bearing point is required. The second issue with *two-span joists* is the presence of negative moments (i.e., reversed bending) near the middle support resulting in the compression *flange* being at the bottom rather than the top of the *joists*. If left unbraced, this could cause lateral instability and result in premature failure of the *joists* under maximum loading conditions. Furthermore, due to the presence of high shear and bending stresses at the middle reactions, shear and bending interaction is checked for *two-span joists*.

Bottom *flange bracing* at interior supports is provided by ceiling finishes (when present) and

by positive connection to the interior bearing wall.

In 2015, as part of a streamlining of AISI S230, tables for multiple spans were deleted and users were permitted to select two-span members using the tables for single spans, with certain exceptions.

D3.1 Floor Cantilevers

Cantilevers supporting structural walls may create special loading conditions that require an engineering analysis. In AISI S230, floor cantilevers are limited to a maximum of 24 inches (610 mm) for floors supporting one wall and roof only (one story). This limitation is imposed to minimize the impact of the added load on the *floor joists*. To fully utilize the strength of the *joist, web* holes are not permitted in cantilevered portions of a *joist*. AISI S230 provides details for cantilevered floors. It is essential that *blocking* be installed between cantilevered *joists* at the bearing locations to adequately transfer floor *diaphragm* or *shear wall* loads (refer to Section D5.4).

D4 Bearing Stiffeners

The *floor joist* spans in AISI S230 were calculated assuming that *bearing stiffeners* (also called *web stiffeners*) are located at all support or bearing point locations. The *bearing stiffeners* are specified to be *C-shaped, track* or *clip angle bearing stiffeners* installed in accordance with Section B2. In 2006, language was added to clarify the requirements for *bearing stiffeners* when *floor joists* are lapped over interior bearing supports and to explicitly require that *floor joists* supporting *jamb studs* with multiple members have two *bearing stiffeners*.

D5 Joist Bracing and Blocking

D5.1 Joist Top Flange Bracing

For typical residential floors, it has been assumed that the function of the floor sheathing is to transfer the loads to the *joists*, and to provide continuous lateral *bracing* to the compression *flanges*. Testing has indicated that using a single *joist* for strength calculation agrees with actual behavior when uniform loads are applied (WJE, 1977).

D5.2 Joist Bottom Flange Bracing/Blocking

Bracing the bottom *flanges* of *joists* as specified in AISI S230 is based on industry practice and engineering judgment. Steel strapping and finished ceilings (e.g., application of gypsum board) are considered to be adequate *bracing* for the tension *flanges*. It is necessary, however, for steel strapping to have *blocking* installed at a maximum spacing of 12 feet (3.7 m) and at the termination ends of all *straps*. Alternatively, the ends of steel *straps* may be fastened to a stable component of the building in lieu of *blocking* (i.e. to a bearing wall or foundation).

D5.3 Blocking at Interior Bearing Supports

Single-span *floor joists* that are lapped over interior supports do not require *blocking* as the lapped sections provide adequate stiffness to prevent lateral movements. Continuous *joists* over interior supports, on the other hand, require *blocking* at every other joist to provide adequate stiffness to prevent lateral movement.

D5.4 Blocking at Cantilevers

Blocking is required for cantilevered supports to transfer shear loads from the floor *diaphragm* or *shear wall*.

D6 Splicing

Splicing of *structural members* is not permitted by AISI S230; however, there may be some situations where splicing would be useful. Applications may include repair of damaged *joists*, and simplified details for dropped floors. In these situations, a *registered design professional* must be consulted.

The *floor joist spans* provided in AISI S230 are based on the assumption that the *joists* are full-length, with no splices. Therefore, splicing of *joist* members in AISI S230 requires an *approved* design except when lapped *joists* occur at interior bearing points.

D7 Framing of Floor Openings

In 2015, the limitation for opening size was added to ensure adequacy of the floor *diaphragm*. Also, because the floor system provides the lateral support for a load-bearing *stud* wall, the requirement that the opening be no closer than 2 feet (0.61 m) from the exterior wall was added. In such cases when the floor opening is less than 2 feet (0.61 m) from the exterior wall, an engineered design is required.

Openings in floors are needed for several reasons (such as at stairs, chases, and chimneys). AISI S230 limits the maximum width of the floor opening to 12 feet (3.6 m) and provides a provision for reinforcing the members around floor openings. All members around floor openings (i.e., *header* and *trimmer joists*) are required to be box-type members made by nesting *C-shaped joists* into a *track* and fastening them together along the top and bottom *flanges*. These built-up members are required to be equal to or greater in size and steel thickness than the *floor joists*, to which they are connected. Each *header joist* is required to be connected to the *trimmer joist* with a *clip angle* on each side of each connection. The *clip angle* is required to be of a thickness equivalent to the *floor joists*. The members around an opening are designed to support joists that have been displaced by the opening. The perimeter members given in AISI S230 do not consider additional stair loads.

D8 Floor Trusses

AISI S230 does not contain provisions for floor *trusses*, which must have an *approved* design. This section is included so that pre-engineered floor *trusses* may be used in conjunction with this document. AISI S240 (AISI, 2015b) should be consulted for the *truss* design.

D9 Diaphragms

Floor *diaphragms* are required to adequately transfer shear loads to the foundation. In steel-framed floors, the shear load transfer is typically accomplished by sheathing the top *flanges* of the *joists* with wood *structural sheathing* (such as OSB or plywood). Shear strength values used in verifying the adequacy of the floor *diaphragms* were taken from AISI S240 (AISI, 2015b) for oriented strand board (OSB) panels fastened to steel members with No. 8 screws at 6 inch (152 mm) on center spacing at panel edges and 12 inch (305 mm) on center spacing at intermediate supports. Additional requirements for steel floors constructed in *high wind* [140 mph (177 km/hr) or greater] or *high seismic areas* (*Seismic Design Category D₀, D₁, D₂* and E) are specified in Section D9.1.

D9.1 Floor Diaphragms in High Seismic and High Wind Areas

Shear strength values used in verifying the adequacy of the floor *diaphragms* were taken from AISI S240 (AISI, 2015b) for oriented strand board (OSB) panels fastened to steel members with No. 8 screws at 6 inch (152 mm) on center spacing at panel edges and 6 inch

(152 mm) on center spacing at intermediate supports. The reduced fastener spacing from 12 inches (305 mm) to 6 inches (152 mm) is to ensure that the *diaphragm* adequately transfers shear loads to the foundation.

E. WALL FRAMING

E2 Wall to Foundation or Floor Connection

Historically, the wall *track* was required to be connected through the floor sheathing to a steel member; i.e., the *floor joist* or *track* below. In 2004, Table E2-1 was revised to enable connection of the wall *track* to the floor sheathing alone (Figure E2-4). This revision was based on research by the NAHB Research Center (NAHBRC, 2003) in which five shear tests and six withdrawal tests were conducted where 33-mil (0.84 mm) *track* was connected to 23/32-inch-thick (18 mm) OSB sheathing using No. 8 screws. The average ultimate shear capacity was 412 lb (187 kg) and the average ultimate pullout capacity was 350 lb (159 kg). Considering that the minimum allowable fastener capacities for steel-to-steel connections for No. 8 screws and 33 mil (0.84 mm) material of 164 lb (74 kg) for shear and 72 lb (32.6 kg) for pullout were used to calculate the requirements for AISI S230, the Committee deemed that it would not be necessary to require that every fastener connect to a *floor joist* or *track* member. In 2007, AISI S230 was expanded to include gable endwall to floor connection requirements for *studs* with heights greater than 10 feet, based on a study at the University of Missouri-Rolla (Downey et al., 2005).

Prior to 2015, the uplift wind requirements were permitted to be reduced by 30% for high wind connections to foundations or floor assemblies. Because the Directional Method replaced the previously used Envelope Method, this reduction was no longer applicable.

E3 Minimum Stud Sizes

This section dictates the minimum required thickness of steel *studs* for different wind speeds, *wind exposure* categories, wall heights, building widths, live loads, and ground snow loads. *Stud* selection tables are limited to buildings not greater than three stories with *structural wall* heights up to 10 feet (3.05 m). In 2007, AISI S230 was expanded to include gable endwall *studs* with heights greater than 10 feet, based on a study at the University of Missouri-Rolla (Downey et al., 2005).

The 8-foot (2.44 m) wall height is widely used in residential construction; however, the higher strength of cold-formed steel wall *studs* enable light-steel-framed construction to provide for higher ceilings such as 9- and 10-foot (2.74 and 3.05 m) walls.

The wall *studs* are grouped into three categories:

- *Studs* for one-story or second floor of two-story building or third floor of a three-story building (supporting roof only)
- *Studs* for first story of a two-story building or second story of a three-story building (supporting roof + one floor)
- *Studs* for first story of a three-story building (supporting roof + two floors)

For walls sheathed on both faces with wood structural panels [minimum 7/16 inch (11.1 mm) OSB or minimum 15/32 inch (11.9 mm) plywood], a reduction in thickness of the *stud* is allowed. All *studs* in exterior walls are treated as *structural members* in AISI S230. The following design assumptions were made in developing the wall *stud* selection tables:

- *Studs* are simply supported beam-columns.
- The exterior *flanges* of the *studs* are braced by *structural sheathing* and the interior *flanges* are braced by mechanical *bracing* [mechanical bracing at mid-height for 8-foot studs (2.4 m), 1/3 point for 9-foot (2.74 m) and 10-foot (3.05 m) and 11'-4" (3.45 m) studs].
- Maximum roof overhang is 24 inches (610 mm).
- Roof slopes are limited to a range of 3:12 to 12:12.

- Deflection limit is $L/240$.
- Ceilings, roofs, attics, and floors span the full width of the house (no interior *bearing* walls).
- Permitted attic live load is limited to 10 psf (0.48 kN/m²).
- Second floor of a two-story building and third floor of a three-story building live load is 30 psf (1.44 kN/m²). Second floor of a three-story building floor live load is 40 psf.
- Unbalanced snow loads is determined in accordance with ASCE 7.

Stud Design

The design of the *studs* was based on the following design checks as stipulated by AISI S240 (AISI, 2015b):

- Combined bending and axial strength using Main Wind Force-Resisting System (MWFRS) wind loads and the bracing as defined by Section E4.
- Bending strength based on Components and Cladding (C&C) loads and the bracing as defined by Section E4.
- Web crippling strength based on Components and Cladding (C&C) loads. Because bending alone was considered, Equation B2.2-1 was used for the development of the *stud* tables.
- Deflection limit based upon 70% of Components and Cladding (C&C) loads.

Wind Design Loads

Components and Cladding (C&C) loads at the ends and corners of walls can be significantly higher than in the middle or field of the wall. However, historically (for residential construction), rather than design the entire wall for these increased corner loads, the loads in the middle of the wall were used to design the *studs*. Thus, the tables in AISI S230 were developed for field of the wall wind loads.

In 2015, Table E3-19 was developed and added to address minimum connection requirements of the wall sheathing for wind suction from C&C wind loads.

E4 Stud Bracing

Studs in structural walls are laterally braced on each *flange* by either a continuous 1-1/2 inch x 33 mil (38.1 x 0.84 mm) (minimum) *strap* at mid-height [or third points for 9-foot (2.74 m) and 10-foot (3.05 m) studs] or by direct attachment of *structural sheathing* or rigid wall finishes (i.e., structural panels such as plywood, OSB or gypsum board), according to the requirements of AISI S230. Therefore, for the evaluation of both the bending strength and axial strength, all *studs* were considered to be braced at mid-height [or third points for 9-foot (2.74 m) and 10-foot (3.05 m) studs] for the engineering analysis of the *stud* tables. As previously noted, the benefit achieved from *structurally sheathed* walls (both wall faces) on the required *stud* thickness and the composite wall strength are recognized by the allowance in dropping down a *stud* thickness for 43 mil Grade 33 *studs*.

Temporary *bracing* may be necessary to facilitate safe construction practices and to ensure that the structural integrity of the wall assembly is maintained. Prior to the installation of cladding or bridging, a wall *stud* is free to twist, thus making the *stud* potentially subject to premature failure under heavy construction loads (i.e., stack of gypsum wallboard or roof shingles). In such cases, temporary *bracing* must be provided.

E5 Splicing

The *stud* tables provided in AISI S230 are based on an assumption that the *studs* are continuous, with no splices. Therefore, *structural studs* shall not be spliced without an *approved*

design. *Tracks* are permitted to be spliced according to the requirements and details in AISI S230.

E6 Corner Framing

AISI S230 utilizes a traditional three-stud practice for framing corners. The corner cavity should be insulated before the exterior sheathing is applied.

E7 Headers

Headers are horizontal members used to transfer loads around openings in *structural walls*. *Headers* specified in AISI S230 are allowed only above the opening immediately below the wall top *track* (i.e., high *headers*). In 2007, an exception to this requirement was included in AISI S230 along with an alternative detail for box and back-to-back *headers* in gable endwalls, based on a study at the University of Missouri-Rolla (Downey et al., 2005). Historically, the two traditional ways of constructing *headers* was to put two *C-shaped* members back-to-back or in a box shape. However, recent testing of single and double L-shaped *headers* has proven that they, as well as inverted L-headers, may be an economical alternative to traditional *headers* in lightly loaded situations.

The following general design assumptions were made in determining *header* spans:

- *Headers* are simply supported beams
- Maximum roof overhang of 24 inches (610 mm)
- Roof slopes limited to a range of 3:12 to 12:12
- Ceilings, roofs, attics, and floors *span* the full width of the house; no interior load bearing walls, except as noted
- Deflection limit of $L/240$

The design of *headers* is based on AISI S240 (AISI, 2015b).

E7.1 Box Headers

Box headers are formed from two equal-sized *C-shaped* members placed toe-to-toe in a box-type configuration and fastened to both the wall top *track* and a *track* below. *Tracks* used to frame around openings are required to have a steel thickness equivalent to or greater than the wall *studs*. The orientation of the lower *track* is not critical to the structural performance of the box *header*. Thus, the lower *track* can be oriented to face either the top or the bottom of the wall. The following design assumptions were used when developing the header selection tables:

- Bending capacity is based on two C-sections alone. The *track* is not considered composite with the C-sections.
- Shear capacity is based on two C-sections alone.
- Interior-one-flange loading web crippling capacity is based on AISI S240 (AISI, 2015b) with a bearing length, $N = 1$.
- End-one-flange loading web crippling capacity is not evaluated because the typical end detail precludes web crippling.
- Bending and web crippling capacities are based on AISI S240 (AISI, 2015b).
- Deflection is based on two C-sections alone. The *track* is not considered composite with the C-sections.

E7.2 Back-to-Back Headers

Back-to-back *headers* are formed from two equal-sized *C-shaped* members in a back-to-

back configuration creating an I-section. These *C-shaped* sections are fastened to the wall top *track* and a lower *track* spanning the width of the opening. *Tracks* used to frame around openings are required to have a steel thickness equal to or greater than the wall *studs*. The lower *track* can be oriented to face either towards the top or the bottom of the wall. It is more difficult to install *strapping* around back-to-back *headers* in *high wind areas*. The following design assumptions were made in developing the header selection tables:

- Bending capacity is based on two C-sections alone. The *track* is not considered composite with the C-sections.
- Shear capacity is based on two C-sections alone.
- Interior-one-flange loading web crippling capacity is based on AISI S100 (AISI, 2012a) with a bearing length, $N = 1$.
- End-one-flange loading web crippling capacity is not evaluated because the typical end detail precludes web crippling.
- Bending and web crippling capacities are based on AISI S100 (AISI, 2012a).
- Deflection is based on two C-sections alone. The *track* is not considered composite with the C-sections.

E7.3 L-Headers

E7.3.1 Double L-Headers

A double *L-header* is shown in Figure E7-5 of AISI S230. Tables for gravity and uplift loads are provided for double *L-headers*. Double *L-headers* are easy to install. They can be installed during or after the wall has been framed. They do not require pre-insulation and provide a large surface to apply finishing materials. They also require less material (steel and screws) than back-to-back or box *headers*. Double *L-headers* do not need to be cut to exact lengths; however, they need to lap over a minimum of one *king stud* at each end. The design of the *L-header* is based on AISI S240 (AISI, 2015b), which stipulates that the bending capacity be based on the angles alone. AISI S240 also stipulates that shear and web crippling alone, as well as combinations of shear, bending or web crippling, need not be checked.

E7.3.2 Single L-Headers

A single *L-header* is shown in Figure E7-6 of AISI S230. Tables for gravity loads only are provided for single *L-headers*. They can be installed during or after the wall has been framed. They do not require pre-insulation and provide a large surface to apply finishing materials. They also require less material (steel and screws) than back-to-back or box *headers*. Single *L-headers* do not need to be cut to exact lengths; however, they need to lap over the required *king studs*. *L-header* strength is usually controlled by wind uplift load since the *L-header* vertical leg is in compression. Inverted *L-headers* (see Section E7.3.3) may be required for wind uplift load. The design of the *L-header* is based on AISI S240 (AISI, 2015b), which stipulates that the bending capacity be based on the angle alone. AISI S240 also stipulates that shear and web crippling alone, as well as combinations of shear, bending or web crippling, need not be checked.

E7.3.3 Inverted L-Headers

An inverted *L-header* is shown in Figure E7-7 of AISI S230. Tables for gravity and uplift loads are provided for inverted *L-headers*. They can be installed during or after the wall has

been framed. They do not require pre-insulation and provide a large surface to apply finishing materials. They also require less material (steel and screws) than back-to-back or box *headers*. Inverted L-headers need to be cut to exact lengths. The design of the L-header is based on AISI S240. AISI S240 stipulates that for double inverted L-headers (double L-headers plus inverted double L-headers), the bending capacity is determined by summing the double L-headers' bending capacities for gravity loading, and summing the inverted double L-headers' bending capacities for uplift loading. For the single inverted L-header (one L-header plus one inverted L-header), AISI S240 states that the gravity capacity is equal to the single L-header bending capacity, and uplift capacity is equal to the inverted single L-header bending capacity. AISI S240 also stipulates that shear and web crippling alone, as well as combinations of shear, bending or *web* crippling, need not be checked.

E7.4 Jack and King Studs

The required number of *jack* and *king studs* was calculated based on the size of the opening. The number was determined by taking the width of the opening, dividing by the *stud* spacing, and rounding to the next higher whole number. The resulting number is further divided into *jack* and *king studs* based on the required axial capacity being provided by the *jack studs* only. *King* and *jack studs* are required to be the same size and thickness as the adjacent wall *studs*. *Jack* and *king studs* are interconnected by *structural sheathing* (plywood or OSB) to transfer lateral loads (when multiple *king* and *jack studs* are required).

E7.5 Head and Sill Track

Head and sill *tracks* are those located at top (i.e., head) or bottom (i.e., sill) of window or door openings. Head and sill *tracks* span the full width of the opening and are designed to resist lateral wind loads only. The allowable head and sill *track* spans were calculated using C&C wind loads for a 48-inch (1.22-m) tributary span [i.e., assuming the opening covers the entire height of the 8-foot (2.44 m) wall.] As the tributary *span* decreases, the head and sill *track* will have to resist less wind loads. Therefore, for a 4-foot (1.22-m) opening, the tributary opening width is 2 feet (0.61 m) and hence the allowable head and sill *track* span increases by a factor of 1.75. Similarly, for a 6-foot (1.83 m) opening, the tributary opening is 3 feet (0.92 m) and hence the allowable head and sill *track* span increases by a factor of 1.50.

E8 Wall Bracing

The wall bracing provisions of this section are applicable to buildings classified as *Seismic Design Category* A, B and C and for buildings located where the *basic wind speed* is less than 140 mph (225 km/hr) Exposure C.

Three different *bracing* methods are recognized in AISI S230:

- Steel *strap bracing* (diagonal X-bracing)
- *Structural sheathing* (plywood or OSB)
- Sheet steel (in *high wind* and *high seismic* regions)

E8.1 Strap Bracing (X-brace)

The wall *bracing* in AISI S230 was conservatively limited to the use of continuously sheathed walls with limitations on loading conditions and building geometry. The use of sheet steel diagonal *strap bracing* must be designed in accordance with *approved* engineering practices.

E8.2 Structural Sheathing

The wall *bracing* requirements in AISI S230 are based on an engineered approach that utilizes available technical knowledge. The allowable shear strength for plywood and oriented strand board (OSB) sheathing are based on Table B5.2.2.3-2 of AISI S240 (AISI, 2015b) and a *safety factor* of 2.5. The *safety factor* of 2.5 is appropriate for *high seismic areas* and is conservative for other cases. The shear strength for assemblies relevant to this document is summarized in Table C-E8.2.

Table C-E8.2
Cold-Formed Steel Framed Walls Shear Strength (AISI S240)

Assembly Description	Nominal Shear Strength (plf)	Allowable Shear Strength (plf)
15/32" Plywood APA Rated sheathing w/ panels on one side	1065	426
7/16" OSB APA Rated sheathing w/ panels on one side	910	364

The intent in AISI S230 is to have the entire building fully sheathed (except for door and window openings, as limited by the minimum length of full-height sheathing).

The lateral wind loads were calculated for a range of building surfaces using the orthogonal wind loading approach of ASCE 7 (ASCE, 2010). Tributary areas consisting of the leeward and windward wall surfaces were assigned to each exterior *shear wall* (i.e., sidewalls and endwalls) to determine the in-plane shear loads to be resisted by the walls.

No interior walls or alternative shear pathways were considered.

Using the more conservative allowable shear strength from Table C-E8.2 of 364 plf (5.39 kN/m), AISI S230 wall *bracing* requirements were determined. The length of full-height sheathing required was then tabulated as a percentage of wall length for sidewalls and endwalls over the range of building geometries defined in AISI S230 applicability limits. The length of wall with full-height sheathing is defined as the sum of wall segments that have sheathing extending from the bottom track to the top track, without interruption due to openings (i.e., the total of lengths of wall between window and door openings). The individual wall segments must be 48 inches (1.22 m) in length or greater to contribute to the required length of full-height sheathing for a given wall line, unless permitted otherwise.

As a final step necessary for a basic prescriptive approach, the requirements were conservatively reduced to the minimum percent lengths of full-height sheathed wall shown in the wall-bracing table of AISI S230. The only building geometry parameter retained was roof slope due to a significant impact on the wind loads transferred to the *shear walls*. Footnotes to the *shear wall* table provide additional information related to the proper applications of the requirements.

Fastening of *structural sheathing* is typically done at 6-inch (152 mm) spacing at the perimeters and 12-inch spacing (305 mm) in the field. When this spacing is reduced to 4 inches (102 mm) (perimeter spacing only), the percentage of full-height sheathing is permitted to be multiplied by 0.72.

A *hold-down anchor* shall consist of an approved *strap* or bracket adequately attached to the *stud* and anchored to the foundation, floor, or wall below to form a continuous load path

to the foundation. *Hold-down anchors* may also be added to reduce the amount of full-height sheathing required, or to increase the shear (racking) strength of the wall.

E9 Exterior Wall Covering

It is required that exterior coverings be installed in accordance with the recommendations of the manufacturer. AISI S230 limits the total exterior envelope dead load (total load = stud framing plus wall coverings) to 10 psf (0.48 kN/m²). If the total exterior envelope dead load exceeds that value, then the walls must be engineered for that load (see Table A1-2 for maximum wall dead loads in high seismic areas).

E11 Braced Walls in High Wind Areas and High Seismic Areas

E11.1 General

This section provides additional *shear wall* requirements for buildings located in *high seismic areas* (i.e., *Seismic Design Categories* D₀, D₁, D₂ and E) or *high wind areas* (i.e., wind speed between 140 to 180 mph (225 to 290 km/hr)). In *high seismic areas*, buildings are required to comply with Sections E11 and E12; and in *high wind areas*, buildings are required to comply with the requirements in Sections E11 and E13.

The following general assumptions and building configurations were used in developing the high seismic tables and high wind provisions:

- Provisions and tables are limited to buildings of no more than two stories.
- Provisions and tables are limited to buildings on slab-on-grade or spread footing with stemwall foundation systems with a single top of slab/top of stemwall elevation.
- Wall clear heights are limited to 8, 9, and 10 feet (2.44, 2.74 and 3.05 m).
- Maximum roof slope is limited to 6.9:12.
- All ceilings are considered leveled (i.e., no offsets or cathedral ceilings).
- Buildings are considered regular (rectangular shape).
- First- and second-story walls are assumed vertically stacked (no offset).

Weights used in calculating the entries of the tables in the *high seismic areas* are as follows:

- Roof/Ceiling dead load = 25 psf (1.2 kN/m²) for heavyweight roofs
= 15 psf (0.72 kN/m²) for normal weight roofs
= 12 psf (0.57 kN/m²) for lightweight roof systems
- Wall dead load = 14 psf (0.67 kN/m²) for heavy walls
= 7 psf (0.34 kN/m²) for light walls
- Floor/Ceiling dead load = 10 psf (0.48 kN/m²)
- Interior wall dead load = 5 psf (0.24 kN/m²) (based on 10-foot (3.04 m) wall)
- Ground snow load = 30 psf (1.44 kN/m²) for normal or lightweight roofs
= 70 psf (3.35 kN/m²) for heavyweight roof systems
- Roof weight includes a 2-foot (610 mm) overhang

The dead loads that were used in determining the seismic mass are given below:

Wall Element	Weight (psf)	
	Lightweight Walls	Heavyweight Walls
Wallboard	1.8	1.8
Steel Framing	0.6	0.6
½" Plywood Sheathing	1.6	1.6
Insulation	1.0	1.0
7/8" Stucco	0	9.0
Exterior Siding	1.5	0
Total	6.5	14.0

For SI: 1 psf = 0.0479 kN/m²

Roof Element	Weight (psf)	
	Flat Roofs	Sloped Roofs (6:12)
Sheathing	1.6	1.63
Roof Framing or Trusses	2.5	2.5
Insulation	1.0	1.0
Miscellaneous	0.6	0.84
Ceiling Covering	1.8	1.8
Subtotal	7.5	7.8
Total with Roof 3.7 psf Covering	11.5	12
Total with Roof 6.4 psf Covering	14.2	15
Total with Roof 15.3 psf Covering	23.5	25

For SI: 1 psf = 0.0479 kN/m²

Roof Category	Roof/Ceiling Weight (psf)
Lightweight Roof	12
Normal Weight Roof	15
Heavyweight Roof	25

For SI: 1 psf = 0.0479 kN/m²

Design assumptions that are used in developing the shear wall and other tables in the high seismic areas are as follows:

- Nominal shear values are taken from Table C-E8.2.
- *Seismic Design Category* (SDC) assignments in accordance with Table R301.2.2.1.1 of the *International Residential Code* (ICC, 2015b).
- Seismic base shears were calculated in accordance with the IBC (ICC, 2012) using an $R = 5.5$ and $\Omega_0 = 2.5$. Upper end S_{DS} values are used for each SDC.
- *Diaphragms* are considered to be flexible rather than rigid. No requirement for inclusion of accidental torsion and reduction of Ω_0 from 3 to 2.5 in accordance with the IBC (ICC, 2012) was used.
- $F_u = 45$ ksi (310 MPa) and $F_y = 33$ ksi (230 MPa) were used in lieu of what the *International Residential Code* (ICC, 2015b) allowed 1.08 tensile/yield ratio in determining screw capacities. *Shear wall* test values are based on the 33 ksi/45 ksi (230/310 MPa) steels.
- ϕ factor was used in combination with the Ω_0 , the over-strength factor, to determine screw requirements for chord splices. Chord splice screw requirements are based on the lesser of Ω_0 times $T_{seismic}$ or T_{n_r} , divided by ϕV_n . Both the 3-1/2 inch (88.9 mm)

and the 5-1/2 inch (140 mm) members were considered, as well as both the 33 mil (0.84 mm) and the 43 mil (1.09 mm) thickness.

- ASCE 7 requires the use of 20% of the uniform design snow load if the flat roof snow load, P_t , exceeds 30 psf (1.44 kN/m²). Where the ground snow load is 70 psf (3.35 kN/m²), the heavy roof system criteria applies.

Example: Load due to 70 psf ground snow load for normal weight roofs =
 $15 \text{ psf} + 0.2 \times 0.7 \times 70 \text{ psf} = 24.8 \text{ psf}$ (1.19 kN/m²) (equals the heavyweight roof systems)

E11.2 Braced Wall Lines

Two types of *braced wall lines* are presented in this section: *Type I* and *Type II Braced Walls*. *Type I braced walls* are traditional *shear walls* that have a *hold-down* anchor at each end and have no openings between anchors. *Type II braced walls*, also known as perforated *shear walls*, are *shear walls* that have openings between anchors and there is no design for shear transfer around the openings.

E11.3 Type I (Solid Sheathed) Braced Wall Panels

This section describes the traditional method of sheathing a steel-framed wall where continuous panels have *hold-down* anchors at each end. The aspect ratio (height-to-width) used in the development of these provisions for this wall type is 2:1.

E11.4 Type II (Perforated) Braced Wall Lines

The *Type II Braced Wall*, or perforated *shear wall* method, requires *hold down* anchors at each end of each wall rather than at each end of continuous panels. The aspect ratio (height to width) is also 2:1 for this wall type. For a defined *Type II* (perforated) *shear wall*, the adjustment factors given in Table E11-2 define the magnitude by which the strength of an otherwise solid wall must be divided to get the strength of the *Type II* (perforated) wall. The tabulated values, adopted from wood frame construction, were justified on the basis of a series of full-scale reversed cyclic tests by Vagh, Dolan and Easterling (2000) in which it was demonstrated that the tested wall capacities were greater than the reductions that are required by Table E11-2.

E12 Braced Wall Design in High Seismic Areas

E12.2 Braced Wall Anchorage and Chord Stud Requirements

In 2015, the tabulated values were changed and expressed in allowable loads. Prior to 2015, AISI S230 permitted the tabulated values to be divided by 1.4 when comparing requirements with manufacturers' published strengths expressed as allowable loads. The derivation of this adjustment factor is: $\phi \times \Omega = 0.55 \times 2.5 = 1.4$. In earlier editions of cold-formed steel lateral design provisions, the resistance factor was set at 0.55 to reflect the 1.4 value used in the UBC to compute allowable seismic loads (1.4 approx. = 0.55×2.5).

E13 Braced Wall Design in High Wind Areas

E13.3 Connections of Walls in High Wind Areas

E13.3.2 Uplift Connection – Wall Assembly to Wall Assembly

In 2015, the tabulated values were changed and expressed in allowable loads. Prior to 2015, AISI S230 permitted the tabulated values to be divided by 1.3 when comparing requirements with manufacturers' published strengths expressed as allowable loads. The derivation of this adjustment factor is: $\phi \times \Omega = 0.60 \times 2.0 = 1.3$.

E13.3.3 Header Uplift Connections

For back-to-back *headers* supporting roof and ceiling only, these provisions require that uplift straps be installed on both sides of the *header* beam (inside and outside of the wall) in order to minimize any effect of torsion. This requirement is based on engineering judgment and recognizes that the back-to-back *header* lacks sufficient torsional strength and stiffness. For back-to-back *headers* supporting loads from one floor, roof and ceiling, and for any box and double L-*headers*, a single uplift strap is permitted and may be installed on either side of the *header* beam.

F. ROOF FRAMING

F1 Roof Construction

Roof *trusses* are not prescriptively addressed in AISI S230 and so as roof girders, but both are permitted in accordance with Section F6. Roof trusses or roof girders must be designed by a *registered design professional*.

F2 Ceiling Joists

F2.1 Minimum Ceiling Joist Size

The *ceiling joist* tables in AISI S230 provide the maximum allowable *ceiling joist* spans for two loading conditions: 10 psf (0.48 kN/m²) and 20 psf (0.96 kN/m²) attic live loads.

For the design of *ceiling joists*, the following design considerations were evaluated:

- Flexural yielding
- Flexural buckling
- Web crippling (not required if *bearing stiffeners* are specified)
- Shear
- Vertical deflection

The engineering approach used to develop *ceiling joist span* tables for AISI S230 is similar to that used for *floor joists*, with the exception of the magnitude of dead and live loads.

F2.2 Ceiling Joist Bearing Stiffeners

Previously, AISI S230 enabled the selection of continuous span *ceiling joists* which required the use of *bearing stiffeners*. Continuous *span joist* tables were removed in 2014.

F2.3 Ceiling Joist Bottom Flange Bracing

Gypsum board (i.e. finished ceilings) is considered to be adequate *bracing* for the bottom (tension) *flanges* of the *ceiling joists*. Steel *strapping* can also be used as bottom *flange bracing* for *ceiling joists*.

F2.4 Ceiling Joist Top Flange Bracing

For braced top (compression) *flanges*, it is necessary for steel strapping to have *blocking* (or bridging) installed at a maximum spacing of 12 feet (3.66 m) and at the termination of all *straps*. Moreover, the ends of steel *straps* are to be fastened to a stable component of the building if end *blocking* is not installed. *Ceiling joist* tables provide *spans* for braced, as well as unbraced, top *flanges*. To stabilize *ceiling joists*, the Standard requires that the *strap bracing* be screwed to *blocking* and the ends of the *strap bracing* be anchored. When the *ceiling joist* depth is 35 inches (88.9 mm), connection requirements are increased due to the increased forces needed to provide restraint to the shallower members.

F2.5 Ceiling Joist Splicing

Splicing of *ceiling joists* in AISI S230 requires an *approved* design except when lapped *ceiling joists* occur at an interior bearing wall.

F3 Roof Rafters

F3.1 Minimum Roof Rafter Sizes

The *roof rafter span* table was designed based primarily on gravity loads, hence the *roof rafter spans* are based on the horizontal projection of the *roof rafter*, regardless of the slope. The gravity loads consist of a 7 psf (0.34 kN/m²) dead load and the greater of a 16 psf (0.77 kN/m²) live load or the applied roof snow load. Unbalanced snow loads in accordance with ASCE 7 were considered.

Wind load effects are developed by a procedure that equates the wind loads to equivalent snow loads as shown in Table F3-2 of AISI S230. Wind pressures were calculated using the ASCE 7 (ASCE, 2010) Components and Cladding (C&C) coefficients. Wind loads acting perpendicular to the plane of the *roof rafter* were adjusted to represent loads acting orthogonal to the horizontal projection of the *roof rafter*. Wind loads were examined for both uplift and downward loads, and the worst case was correlated to a corresponding snow load.

Permissible roof slopes range between 3:12 through 12:12 and more importantly, the roof system must consist of both *ceiling joists* (i.e., acting as rafter ties) and *roof rafters*. AISI S230 does not currently address cathedral ceilings because a prescriptive ridge beam and post design is not provided.

Lapped *ceiling joists* must be connected with the same screw size and number (or more) as the heel joint connection to ensure adequate transfer of tension loads across the spliced joint. The splice must occur over an interior bearing wall.

F3.1.1 Eave Overhang

A 24-inch (610 mm) eave overhang was used when calculating the *roof rafter spans* in AISI S230.

F3.1.2 Rake Overhang

In 2007, limitations and details were added to AISI S230 to clarify the installation requirements at gable endwalls, based on a study at University of Missouri-Rolla (Downey et al., 2005).

F3.2 Roof Rafter Support Brace

The support brace is used to increase the *span* of a particular member. When the brace is used, the *roof rafter span* is determined from the heel joint to the brace point or from the ridge member to the brace point (horizontal projection), whichever is greater.

F3.3 Roof Rafter Splice

The *roof rafter spans* provided in AISI S230 are based on the assumption that the members are continuous, with no splices. Therefore, *roof rafters* are not to be spliced without an *approved design*.

F3.5 Roof Rafter Bottom Flange Bracing

The *bracing* requirements provided in AISI S230 are commonly used in residential steel construction and are based on engineering judgment.

F4 Hip Framing

Prior to the 2007 edition of this Standard, roof framing was limited to *roof rafters* and *ceiling joists*. Hip and valley framing options were added in 2007, based on research at the University of Missouri-Rolla (Waldo et al., 2006).

F5 Framing of Openings in Roofs and Ceilings

The requirements of this section are based on engineering judgment.

In 2015, the limitation for opening size was added to ensure adequacy of the *diaphragm*. Also, to preserve the tolerance limits required for in-line framing and transfer the more heavily loaded trimmer *joist* end reactions, requirements were added that in roof or ceiling assemblies supported by wall framing, a built-up trimmer *joist* consisting of at least one pair of *joist* or *track* members must be supported by a pair of wall *studs*.

F6 Roof Trusses

AISI S230 does not contain provisions for *roof trusses*, which must have an *approved* design. This section is included so that pre-engineered *roof trusses* may be used in conjunction with this document. AISI S240 (AISI, 2015b) should be consulted for the *truss* design.

F7 Ceiling and Roof Diaphragms

Roof *diaphragms* are required to adequately transfer shear loads to the *braced wall lines* in a structure. The load transfer is typically accomplished by sheathing the roof-framing members with wood structural panels. Shear values used in the design of roof *diaphragms* were taken from AISI S240 (AISI, 2015b). Additional requirements for steel roof *diaphragms* in *high wind areas* (i.e., 140 mph (225 km/hr) or greater wind speed) or *high seismic areas* (i.e., *Seismic Design Category D₀, D₁, D₂ and E*) are specified in Sections F7.1 and F7.2.

Ceiling *diaphragms* are also required to adequately transfer shear loads to the *braced wall lines* in a structure. The load transfer is typically accomplished by sheathing the ceiling-framing members with gypsum board or wood structural panels. Shear values used in the design of ceiling *diaphragms* were taken from AISI S240 (AISI, 2015b).

In 2015, Table F2-5 was developed and added to address minimum connection requirements of the roof sheathing for wind suction from C&C wind loads.

REFERENCES

- (AISC, 1991), *Structural Performance Requirements for Domestic Steel Framing*, Australian Institute of Steel Construction, Milsons Point, Australia, 1991.
- (AISI, 2011), *North American Standard for Cold-Formed Steel Framing – Nonstructural Members*, AISI S220-11, American Iron and Steel Institute, Washington, DC, 2011.
- (AISI, 2012a), *North American Specification for the Design of Cold-Formed Steel Structural Members*, AISI S100-12, American Iron and Steel Institute, Washington, DC, 2012.
- (AISI, 2012b), *North American Standard for Cold-Formed Steel Framing – Product Data*, AISI S201-12, American Iron and Steel Institute, Washington, DC, 2012.
- (AISI, 2013), *Cold-Formed Steel Design Manual*, AISI D100-13, American Iron and Steel Institute, Washington, DC, 2013.
- (AISI, 2015a), *North American Standard for Cold-Formed Steel Framing – Prescriptive Method for One- and Two-Family Dwellings*, AISI S230-15, American Iron and Steel Institute, Washington, DC, 2015.
- (AISI, 2015b), *North American Standard for Cold-Formed Steel Structural Framing*, AISI S240-15, American Iron and Steel Institute, Washington, DC, 2015.
- (ASCE, 2010), *ASCE 7, Minimum Design Loads for Buildings and Other Structures*, American Society of Civil Engineers, Reston, VA, 2010.
- (ASTM, 2010), *ASTM C954, Standard Specification for Steel Drill Screws for the Application of Gypsum Panel Products or Metal Plaster Bases to Steel Studs From 0.033 in. (0.84 mm) to 0.112 in. (2.84 mm) in Thickness*, ASTM International, West Conshohocken, PA, 2010.
- (ASTM, 2007), *ASTM C1002, Standard Specification for Steel Self-Piercing Tapping Screws for the Application of Gypsum Panel Products or Metal Plaster Bases to Wood Studs or Steel Studs*, ASTM International, West Conshohocken, PA, 2007.
- (AWC, 2012), *Wood Frame Construction Manual for One- and Two-Family Dwellings*, American Wood Council, Leesburg, VA, 2012.
- (ICC, 2015a), *International Building Code*, International Code Council, Falls Church, VA, 2015.
- (ICC, 2015b), *International Residential Code*, International Code Council, Falls Church, VA, 2015.
- Downey, B.W, S.F. Stephens and R.A. LaBoube (2005), *“Cold-Formed Steel Gable End Wall Design for the Prescriptive Method for One- and Two-Family Dwellings,”* Final Report, Department of Civil Engineering, Wei-Wen Yu Center for Cold-Formed Steel Structures, University of Missouri-Rolla, Rolla, MO.
- (NAHBRC, 2003), *Hybrid Wood and Steel Sole Plate Connection Walls to Floors Testing Report*, National Association of Home Builders’ Research Center, Upper Marlboro, MD, 2003.
- Sivakumaran, K.S. (2007), *Reinforcement Schemes for Cold-Formed Steel Joists Having Web Openings*, Final Report, McMaster University, Hamilton, Ontario, Canada, 2007.
- Vagh, Dolan and Easterling (2000), *Effect of Anchorage and Sheathing Configuration on the Cyclic Response of Long Steel-Frame Shear Walls*, Report No. TE-2000-002, Virginia Polytechnic Institute and State University, Blacksburg, VA, 2000.
- Waldo, L., S.F. Stephens and R.A. LaBoube (2006), *“Residential Hip Roof Framing Using Cold-Formed Steel Members,”* Final Report, Department of Civil Engineering, Wei-Wen Yu Center for

Cold-Formed Steel Structures, University of Missouri-Rolla, Rolla, MO.

Wiss, Janney, Elstner Associates (1977), Report Number 73345, *Report of Laboratory Tests and Analytical Studies of Structural Characteristics of Cold-Formed Steel-Joist Floor Systems*, San Francisco, CA, 1977.



25 Massachusetts Avenue NW
Suite 800
Washington, DC 20001
www.steel.org





25 Massachusetts Avenue NW
Suite 800
Washington, DC 20001
www.steel.org





**American
Iron and Steel
Institute**

25 Massachusetts Avenue NW
Suite 800
Washington, DC 20001
www.steel.org

