

Wood I Beam™ Joists

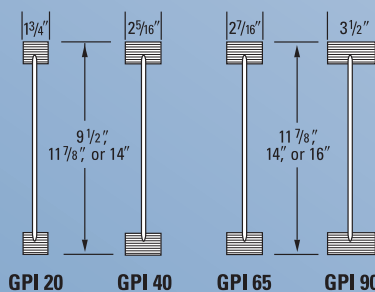

All Wood I Beam joists have an enhanced OSB web. Referenced dimensions are nominal and used for design purposes. Not all products are available at all distribution centers; contact Georgia-Pacific for product availability.

GPI Series (LVL Flanges)



WI Series (Lumber Flanges)

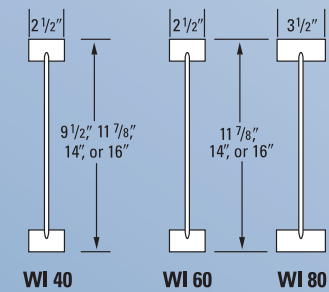

Greater load-carrying capacity, firmer-feeling floors

Lightweight and cost effective, WI and GPI Series Wood I Beam™ joists are the builder's choice for residential floor and roof systems. A wide selection of sizes and flange choices make it easy to specify the materials that are right for the homes you build, whether you're building production homes or custom plans.

Each joist features an enhanced OSB web with high-grade solid sawn lumber or GP Lam® LVL flanges. The wider flanges offered by the 40, 60, 65, 80, and 90 series joists provide broader gluing and nailing surfaces for sheathing, helping to save time and money for builders. Occupants enjoy the benefits of firm, level floors and smooth, flat ceilings.

More stable floors

When used as part of a flooring system, Wood I Beam joists can help floors stay quiet over time, reducing bothersome and costly callbacks. Conventional lumber can shrink, twist and warp as the moisture found naturally in the wood evaporates. Floors can bow, nails pull away from the joists, and the floor decking slides up and down against the nails, creating annoying squeaks.

In contrast, Wood I Beam joists are more stable by design. The wide flange helps reduce vibration, creating a firmer feeling floor. Wood I Beam joists are produced at a lower moisture content, thereby minimizing the effects of shrinking, twisting, and warping.



Available depths and lengths

- Some series are available in deeper depths by special order.
- All joists are available in value lengths of 24', 28', 32', 36', 40', 44', and 48'.
- Lengths up to 60' may be special ordered.
- Lifetime Limited Warranty.*

* See manufacturer's warranty for terms, conditions and limitations, available at www.gp.com/build or by calling 800-284-5347.

System performance

The ultimate goal in the design of a floor or roof system is the end user's safety and satisfaction. **Although joists used at spans indicated in this guide meet or exceed minimum code criteria and will safely support the loads imposed on them, judgement must be used to adequately meet user expectation levels.** These expectations may vary from one user to another.

- The specifier should consider the meaning of a given deflection limit in terms of allowable deflection and the effects this could have on the system. For example, L/360 (span/360) for a 30' span is 1" of deflection. L/240 would be 1½", and L/180 would be 2" of deflection. Consideration might also be given to cases in which a joist with a long span parallels a short span or a foundation end wall. For example, a 30' span with up to 1" of allowable live load deflection could be

adjacent to an end wall with no deflection, causing a noticeable difference in floor levels under full design load.

- **A stiffer floor will result from using a live load deflection limit of L/480 versus the code minimum L/360.** A roof system with less total load deflection than the code required L/180 may be achieved by using an L/240 criterion.
- In addition to more stringent deflection limits, several other factors may improve overall floor performance. **Reducing joist spacing and/or increasing the subfloor thickness will lessen deflection between adjacent joists and increase load sharing. For increased floor stiffness, gluing the subfloor to the joists is recommended before nailing or screwing rather than nailing only.**
- As with any construction, it is essential to follow proper installation procedures. Joists must be plumb and anchored securely to supports

before system sheathing is attached. Supports for multiple span joists must be level. To minimize settlement when using hangers, joists should be firmly seated in the hanger bottoms. Leave a 1/16" gap between joist end and header.

- **Vibrations may occur in floor systems with very little dead load,** as in large empty rooms. A gypsum wallboard ceiling attached to the bottom of the joists will generally dampen vibration as will interior partition walls running perpendicular to the joists. If a ceiling will not be attached to the bottom of the joists, vibration can be minimized by nailing a continuous 2x4 perpendicular to the bottom of the joists at midspan running from end wall to end wall. Where future finishing of the ceiling is likely, x-bridging or Wood I Beam blocking panels may be used in place of the 2x4.

Floor Joist Maximum Spans

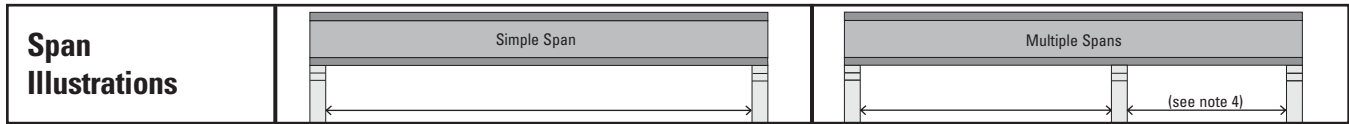

40 PSF Live Load + 10 PSF Dead Load Improved Performance (L/480)

Joist Series	Joist Depth	Spacing (Simple Span)				Spacing (Multiple Span)			
		12' o.c.	16' o.c.	19.2' o.c.	24' o.c.	12' o.c.	16' o.c.	19.2' o.c.	24' o.c.
GPI 20	9 1/2"	17'-01"	15'-07"	14'-09"	13'-10"	18'-07"	17'-00"	16'-01"	15'-00"
	11 7/8"	20'-05"	18'-08"	17'-08"	16'-06"	22'-03"	20'-04"	19'-02"	17'-05"
	14"	23'-03"	21'-03"	20'-01"	18'-09"	25'-04"	23'-02"	21'-04"	18'-06"
GPI 40	9 1/2"	18'-00"	16'-06"	15'-07"	14'-07"	19'-08"	17'-11"	16'-11"	15'-06"
	11 7/8"	21'-06"	19'-08"	18'-07"	17'-04"	23'-05"	21'-05"	19'-09"	17'-08"
	14"	24'-04"	22'-03"	21'-01"	19'-05"	26'-07"	23'-09"	21'-08"	19'-04"
GPI 65	11 7/8"	23'-03"	21'-03"	20'-00"	18'-08"	25'-04"	23'-01"	21'-09"	20'-04"
	14"	26'-05"	24'-02"	22'-09"	21'-03"	28'-10"	26'-03"	24'-09"	20'-08"
	16"	29'-04"	26'-09"	25'-03"	23'-07"	32'-00"	29'-02"	25'-11"	20'-08"
GPI 90	11 7/8"	26'-04"	24'-00"	22'-07"	21'-00"	28'-08"	26'-01"	24'-07"	22'-10"
	14"	29'-11"	27'-02"	25'-07"	23'-10"	32'-07"	29'-07"	27'-10"	25'-11"
	16"	33'-01"	30'-01"	28'-04"	26'-04"	36'-01"	32'-09"	30'-10"	26'-07"
WI 40	9 1/2"	18'-00"	16'-05"	15'-06"	14'-06"	19'-07"	17'-11"	16'-04"	14'-07"
	11 7/8"	21'-05"	19'-07"	18'-06"	16'-08"	23'-05"	20'-05"	18'-07"	16'-07"
	14"	24'-04"	22'-03"	20'-06"	18'-04"	25'-11"	22'-05"	20'-05"	18'-03"
WI 60	11 7/8"	22'-07"	20'-08"	19'-06"	18'-02"	24'-08"	22'-06"	21'-02"	19'-07"
	14"	25'-09"	23'-06"	22'-02"	20'-08"	28'-00"	25'-07"	24'-01"	19'-09"
	16"	28'-06"	26'-00"	24'-07"	22'-10"	31'-01"	28'-04"	24'-09"	19'-09"
WI 80	11 7/8"	24'-11"	22'-08"	21'-04"	19'-10"	27'-01"	24'-08"	23'-03"	21'-07"
	14"	28'-03"	25'-09"	24'-03"	22'-07"	30'-10"	28'-00"	26'-05"	23'-11"
	16"	31'-04"	28'-06"	26'-10"	25'-00"	34'-02"	31'-01"	29'-03"	23'-11"

40 PSF Live Load + 20 PSF Dead Load Improved Performance (L/480)

Joist Series	Joist Depth	Spacing (Simple Span)				Spacing (Multiple Span)			
		12' o.c.	16' o.c.	19.2' o.c.	24' o.c.	12' o.c.	16' o.c.	19.2' o.c.	24' o.c.
GPI 20	9 1/2"	17'-01"	15'-07"	14'-09"	13'-10"	18'-07"	17'-00"	15'-07"	13'-11"
	11 7/8"	20'-05"	18'-08"	17'-08"	15'-11"	22'-03"	19'-05"	17'-09"	15'-05"
	14"	23'-03"	21'-03"	19'-06"	17'-05"	24'-08"	21'-04"	19'-03"	15'-05"
GPI 40	9 1/2"	18'-00"	16'-06"	15'-07"	14'-02"	19'-08"	17'-04"	15'-10"	14'-02"
	11 7/8"	21'-06"	19'-08"	18'-01"	16'-02"	22'-10"	19'-09"	18'-00"	16'-01"
	14"	24'-04"	21'-09"	19'-10"	17'-09"	25'-01"	21'-08"	19'-09"	17'-01"
GPI 65	11 7/8"	23'-03"	21'-03"	20'-00"	18'-08"	25'-04"	23'-01"	21'-06"	17'-02"
	14"	26'-05"	24'-02"	22'-09"	21'-03"	28'-10"	25'-11"	21'-06"	17'-02"
	16"	29'-04"	26'-09"	25'-03"	22'-03"	32'-00"	25'-11"	21'-06"	17'-02"
GPI 90	11 7/8"	26'-04"	24'-00"	22'-07"	21'-00"	28'-08"	26'-01"	24'-07"	22'-02"
	14"	29'-11"	27'-02"	25'-07"	23'-02"	32'-07"	29'-07"	27'-09"	22'-02"
	16"	33'-01"	30'-01"	28'-04"	23'-02"	36'-01"	32'-09"	27'-09"	22'-02"
WI 40	9 1/2"	18'-00"	16'-05"	14'-11"	13'-04"	18'-11"	16'-04"	14'-11"	13'-03"
	11 7/8"	21'-05"	18'-08"	17'-01"	15'-03"	21'-06"	18'-07"	17'-00"	15'-02"
	14"	23'-09"	20'-06"	18'-09"	16'-09"	23'-08"	20'-05"	18'-08"	16'-05"
WI 60	11 7/8"	22'-07"	20'-08"	19'-06"	17'-11"	24'-08"	21'-11"	20'-00"	16'-05"
	14"	25'-09"	23'-06"	22'-00"	19'-08"	27'-10"	24'-01"	20'-07"	16'-05"
	16"	28'-06"	26'-00"	23'-09"	19'-10"	30'-00"	24'-09"	20'-07"	16'-05"
WI 80	11 7/8"	24'-11"	22'-08"	21'-04"	19'-10"	27'-01"	24'-08"	22'-09"	18'-02"
	14"	28'-03"	25'-09"	24'-03"	21'-02"	30'-10"	28'-00"	24'-11"	19'-11"
	16"	31'-04"	28'-06"	26'-06"	21'-02"	34'-02"	30'-00"	24'-11"	19'-11"

NOTES:

- These span tables are based on uniform loads, as noted above; live load deflection is limited to L/480 for better performance. Floor performance is greatly influenced by the stiffness of the floor joists. Experience has shown that joists designed to the code minimum live load deflection (L/360) will result in a floor which may not meet the expectations of some end users. Floor spans for Wood I Beam joists in accordance with those given above are strongly recommended, which are based on L/480 live load deflection. (One-third stiffer than required by code.)
- Spans are clear distances between supports, and are based on composite action with glued-nailed APA Rated[®] sheathing or Sturd-I-Floor[®] panels of minimum thickness 1 9/32" (40/20 or 20 o.c.) for joist spacing of 19.2" or less, or 2 3/32" (48/24 or 24 o.c.) for a joist spacing of 24".

Adhesive must meet APA AFG-01 or ASTM D 3498. Apply a continuous line of adhesive (about 1/4" diameter) to top flange of joists. All surfaces must be clean and dry. If sheathing is nailed only (not recommended), reduce spans by 12".

- Minimum end bearing length is 1 3/4". Minimum intermediate bearing length is 3 1/2".
- For multiple-span joists: End spans must be at least 40% of the adjacent span. Spans shown above cover a broad range of applications. It may be possible to exceed these spans by analyzing a specific application with FASTBeam[®] selection software.
- For loading other than that shown above, refer to Uniform Load Tables, use FASTBeam software, or contact Georgia-Pacific Engineered Lumber Technical Services.

Bonus Room Floor Joist Selection Guide

L (Span)	X (Kneewall Location)	WI Joists (Series – Depth) ¹				GPI Joists (Series – Depth) ¹			
		Spacing				Spacing			
		12' o.c.	16' o.c.	19.2' o.c.	24' o.c.	12' o.c.	16' o.c.	19.2' o.c.	24' o.c.
20'	4'	60-11 ⁷ / ₈ "	60-14"	60-16"	80-16" ²	65-11 ⁷ / ₈ "	65-14"	65-14"	65-16" ³
	5'	60-11 ⁷ / ₈ "	60-14"	60-16"	80-16" ²	65-11 ⁷ / ₈ "	65-14"	65-14"	65-16"
	6'	60-11 ⁷ / ₈ "	60-14"	60-16"	80-16"	65-11 ⁷ / ₈ "	65-14"	65-14"	65-16"
22'	4'	60-14"	60-16"	80-16"	80-16" ^{3,4}	65-14"	65-16"	65-16"	90-16" ³
	5'	60-14"	60-16"	80-16"	80-16" ³	65-14"	65-16"	65-16"	90-16" ²
	6'	60-14"	60-16"	80-16"	80-16" ²	65-14"	65-16"	65-16"	90-16" ²
24'	4'	60-16"	80-16"	80-16" ²	Dbl 60-16"	65-16"	65-16"	90-16"	Dbl 65-16"
	5'	60-16"	80-16"	Dbl 60-16"	Dbl 60-16"	65-16"	90-14"	90-16"	Dbl 65-16"
	6'	60-16"	80-16"	Dbl 60-16"	Dbl 60-16"	65-16"	90-14"	90-16"	Dbl 65-16"
	7'	60-16"	80-16"	Dbl 60-16"	Dbl 60-16"	65-16"	90-14"	90-16"	Dbl 65-16"
26'	4'	80-16"	Dbl 60-16"	Dbl 60-16"	Dbl 80-16"	65-16"	90-16"	Dbl 65-16"	Dbl 90-14"
	5'	80-16"	Dbl 60-16"	Dbl 60-16"	Dbl 80-16"	65-16"	90-16"	Dbl 65-16"	Dbl 90-16"
	6'	80-16"	Dbl 60-16"	Dbl 60-16"	Dbl 80-16"	65-16"	90-16"	Dbl 65-16"	Dbl 90-16"
	7'	80-16"	Dbl 60-16"	Dbl 60-16"	Dbl 80-16"	65-16"	90-16"	Dbl 65-16"	Dbl 90-16"

1. Double joist (2-ply) is denoted by "Dbl". Both joists must be glued and nailed as required for floor sheathing. No filler blocking required when top-loaded only.
2. A 2½" minimum bearing length must be provided by support wall or hanger seat.
3. A 3" minimum bearing length must be provided by support wall or hanger seat.
4. To be used in this application, the joist requires bearing stiffeners at both ends per detail F18.

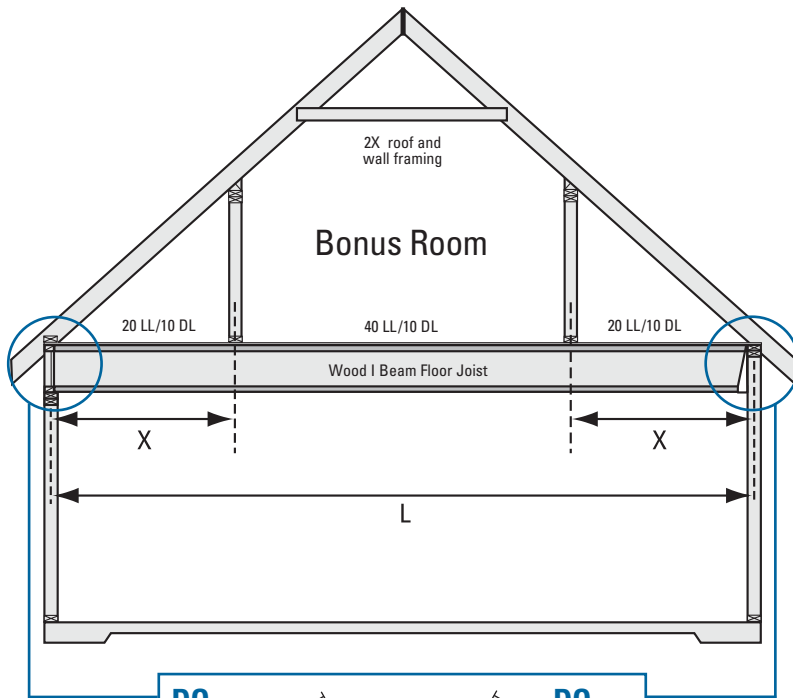

DESIGN PARAMETERS:

1. Glued and nailed floor sheathing.
2. Deflection limits: L/240 total load, L/480 live load, unless noted otherwise.
3. Roof loads of 30 PSF live load at 115% (snow load).
4. Roof dead load of 12 PSF (asphalt shingles).
5. Roof rafter slope between 8/12 and 12/12.
6. Kneewall weight of 40 PLF.
7. Attic storage load of 20 PSF live load (outside the kneewalls).
8. Floor live load of 40 PSF (between the kneewalls).
9. Attic and floor dead load of 10 PSF.
10. Straight gable roof framing. No hip framing is permitted.
11. For other conditions, including holes, use FASTBeam® software or call Georgia-Pacific at 800-284-5347.

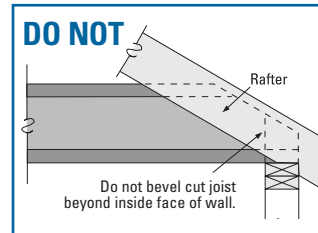
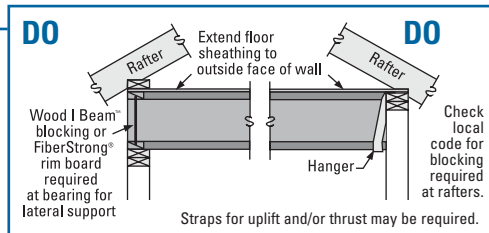

Roof Joist Maximum Spans

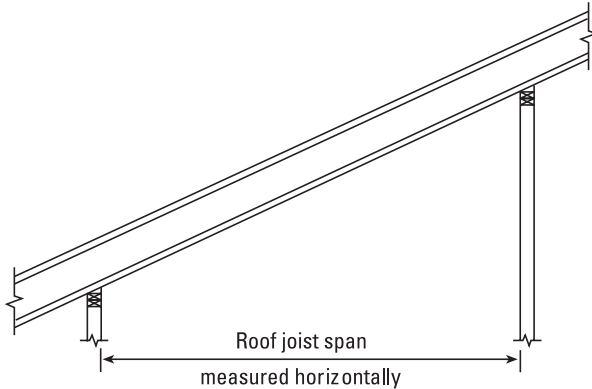

Notes:

1. Roof joists to be sloped min. ¼" in 12". No camber provided.
2. Maximum deflection is limited to L/180 at total load, L/240 at live load.
3. Maximum slope is limited to 12" in 12" for use of these tables.
4. Tables are based on the more restrictive of simple or multiple spans.
5. End spans of multiple-span joists must be at least 40% of the adjacent span.
6. For other loading conditions or on-center spacings, refer to Uniform Load Tables or use FASTBeam® selection software.
7. Minimum end bearing length is 1¾". Minimum intermediate bearing length is 3½".
8. Spans shown below cover a broad range of applications. It may be possible to exceed these spans by analyzing a specific application using FASTBeam software.
9. Tables apply to gravity loads only.
10. Dead load is calculated along the joist length.
11. 20 psf non-snow live loads have been reduced per code for slopes of over 8/12 through 12/12.

Roof Joist Maximum Spans – 115% (Snow)

Refer to Notes above.

Load (PSF)	Joist Series	Joist Depth	Slope of 4/12 or less			Slope of over 4/12 through 8/12			Slope of over 8/12 through 12/12			
			16" o.c.	19.2" o.c.	24" o.c.	16" o.c.	19.2" o.c.	24" o.c.	16" o.c.	19.2" o.c.	24" o.c.	
Snow 115%	GPI 20	9½"	19'-09"	18'-07"	17'-02"	18'-07"	17'-06"	16'-02"	17'-03"	16'-02"	15'-00"	
		11⅞"	23'-09"	22'-04"	20'-08"	22'-04"	21'-00"	19'-05"	20'-09"	19'-05"	18'-00"	
		14"	27'-02"	25'-04"	22'-08"	25'-07"	24'-00"	22'-01"	23'-08"	22'-03"	20'-07"	
	GPI 40	9½"	21'-01"	19'-10"	18'-04"	19'-10"	18'-08"	17'-03"	18'-05"	17'-03"	16'-00"	
		11⅞"	25'-03"	23'-06"	21'-00"	23'-09"	22'-04"	20'-05"	22'-00"	20'-08"	19'-02"	
		14"	28'-03"	25'-09"	23'-00"	27'-00"	25'-01"	22'-05"	25'-00"	23'-06"	21'-07"	
	GPI 65	11⅞"	27'-08"	26'-00"	24'-00"	26'-01"	24'-06"	22'-08"	24'-02"	22'-08"	21'-00"	
		14"	31'-06"	29'-07"	27'-05"	29'-08"	27'-11"	25'-10"	27'-06"	25'-10"	23'-11"	
		16"	35'-00"	32'-11"	29'-10"	33'-00"	31'-00"	28'-08"	30'-07"	28'-09"	26'-07"	
	GPI 90	11⅞"	31'-09"	29'-10"	27'-07"	29'-11"	28'-01"	26'-00"	27'-09"	26'-01"	24'-01"	
		14"	36'-01"	33'-10"	31'-04"	34'-00"	31'-11"	29'-07"	31'-06"	29'-07"	27'-05"	
		16"	39'-11"	37'-06"	34'-09"	37'-08"	35'-04"	32'-09"	34'-10"	32'-09"	30'-04"	
	Live 25 Dead 15	WI 40	9½"	21'-01"	19'-05"	17'-04"	19'-10"	18'-08"	16'-11"	18'-05"	17'-03"	16'-00"
			11⅞"	24'-03"	22'-02"	19'-09"	23'-07"	21'-07"	19'-03"	22'-00"	20'-08"	18'-07"
			14"	26'-08"	24'-04"	21'-09"	25'-11"	23'-08"	21'-02"	25'-00"	22'-10"	20'-05"
	WI 60	11⅞"	26'-10"	25'-02"	23'-03"	25'-03"	23'-09"	22'-00"	23'-05"	22'-00"	20'-04"	
		14"	30'-07"	28'-07"	25'-07"	28'-10"	27'-01"	24'-11"	26'-08"	25'-01"	23'-03"	
		16"	33'-09"	30'-10"	27'-06"	32'-00"	30'-00"	26'-10"	29'-08"	27'-10"	25'-09"	
	WI 80	11⅞"	29'-10"	28'-00"	25'-11"	28'-01"	26'-05"	24'-05"	26'-01"	24'-06"	22'-08"	
		14"	33'-11"	31'-10"	29'-06"	32'-00"	30'-00"	27'-10"	29'-08"	27'-10"	25'-09"	
		16"	37'-08"	35'-04"	32'-09"	35'-06"	33'-04"	30'-10"	32'-10"	30'-11"	28'-07"	
	Snow 115%	GPI 20	9½"	19'-00"	17'-10"	16'-06"	17'-11"	16'-10"	15'-07"	16'-08"	15'-08"	14'-06"
			11⅞"	22'-10"	21'-05"	19'-06"	21'-06"	20'-03"	18'-09"	20'-00"	18'-09"	17'-05"
			14"	26'-01"	23'-11"	21'-04"	24'-08"	23'-02"	20'-10"	22'-11"	21'-06"	19'-11"
GPI 40		9½"	20'-03"	19'-00"	17'-05"	19'-01"	17'-11"	16'-07"	17'-09"	16'-08"	15'-05"	
		11⅞"	24'-03"	22'-02"	19'-10"	22'-11"	21'-06"	19'-04"	21'-03"	20'-00"	18'-06"	
		14"	26'-08"	24'-04"	21'-09"	26'-00"	23'-09"	21'-02"	24'-02"	22'-08"	20'-06"	
GPI 65		11⅞"	26'-07"	24'-11"	23'-01"	25'-01"	23'-07"	21'-10"	23'-04"	21'-11"	20'-03"	
		14"	30'-03"	28'-05"	26'-04"	28'-07"	26'-10"	24'-10"	26'-07"	24'-11"	23'-01"	
		16"	33'-08"	31'-07"	26'-06"	31'-09"	29'-10"	27'-05"	29'-06"	27'-09"	25'-08"	
GPI 90		11⅞"	30'-06"	28'-08"	26'-06"	28'-10"	27'-01"	25'-00"	26'-09"	25'-02"	23'-03"	
		14"	34'-08"	32'-07"	30'-01"	32'-09"	30'-09"	28'-05"	30'-05"	28'-07"	26'-05"	
		16"	38'-05"	36'-00"	33'-04"	36'-03"	34'-00"	31'-06"	33'-08"	31'-07"	29'-03"	
Live 30 Dead 15		WI 40	9½"	20'-01"	18'-04"	16'-04"	19'-01"	17'-11"	16'-00"	17'-09"	16'-08"	15'-05"
			11⅞"	22'-11"	20'-11"	18'-08"	22'-04"	20'-05"	18'-02"	21'-03"	19'-09"	17'-08"
			14"	25'-02"	22'-11"	20'-06"	24'-07"	22'-05"	20'-00"	23'-09"	21'-08"	19'-04"
WI 60		11⅞"	25'-09"	24'-02"	22'-00"	24'-04"	22'-10"	21'-02"	22'-07"	21'-03"	19'-08"	
		14"	29'-05"	27'-00"	24'-01"	27'-09"	26'-01"	23'-07"	25'-09"	24'-02"	22'-05"	
		16"	31'-10"	29'-01"	25'-04"	30'-10"	28'-05"	25'-04"	28'-07"	26'-11"	24'-07"	
WI 80		11⅞"	28'-08"	26'-11"	24'-11"	27'-01"	25'-05"	23'-06"	25'-02"	23'-07"	21'-10"	
		14"	32'-07"	30'-07"	28'-04"	30'-10"	28'-11"	26'-09"	28'-07"	26'-10"	24'-11"	
		16"	36'-02"	34'-00"	30'-08"	34'-02"	32'-01"	29'-08"	31'-09"	29'-10"	27'-07"	

Table continues on next page.

Roof Joist Maximum Spans – 115% (Snow) continued

Refer to Notes on page 8.

Load (PSF)	Joist Series	Joist Depth	Slope of 4/12 or less			Slope of over 4/12 through 8/12			Slope of over 8/12 through 12/12			
			16" o.c.	19.2" o.c.	24" o.c.	16" o.c.	19.2" o.c.	24" o.c.	16" o.c.	19.2" o.c.	24" o.c.	
Snow 115%	GPI 20	9½"	17'-09"	16'-08"	15'-05"	16'-10"	15'-09"	14'-07"	15'-08"	14'-08"	13'-07"	
		11⅞"	21'-04"	19'-09"	17'-08"	20'-02"	18'-11"	17'-04"	18'-10"	17'-08"	16'-04"	
		14"	23'-09"	21'-08"	19'-04"	23'-01"	21'-03"	19'-00"	21'-06"	20'-03"	18'-05"	
	GPI 40	9½"	18'-11"	17'-07"	15'-09"	17'-11"	16'-10"	15'-05"	16'-08"	15'-08"	14'-06"	
		11⅞"	22'-00"	20'-01"	17'-11"	21'-06"	19'-08"	17'-07"	20'-00"	18'-09"	17'-01"	
		14"	24'-01"	22'-00"	19'-08"	23'-08"	21'-07"	19'-03"	22'-09"	21'-00"	18'-09"	
	GPI 65	11⅞"	24'-10"	23'-03"	21'-06"	23'-06"	22'-01"	20'-05"	21'-11"	20'-07"	19'-01"	
		14"	28'-03"	26'-07"	21'-07"	26'-09"	25'-02"	22'-05"	25'-00"	23'-05"	21'-09"	
		16"	31'-05"	27'-01"	21'-07"	29'-09"	27'-11"	22'-05"	27'-09"	26'-01"	24'-02"	
	GPI 90	11⅞"	28'-06"	26'-09"	24'-09"	27'-00"	25'-04"	23'-05"	25'-02"	23'-08"	21'-11"	
		14"	32'-04"	30'-05"	27'-10"	30'-08"	28'-09"	26'-08"	28'-07"	26'-10"	24'-10"	
		16"	35'-10"	33'-08"	27'-10"	33'-11"	31'-10"	27'-07"	31'-08"	29'-09"	26'-02"	
	WI 40	9½"	18'-02"	16'-07"	14'-10"	17'-10"	16'-03"	14'-06"	16'-08"	15'-08"	14'-01"	
		11⅞"	20'-09"	18'-11"	16'-10"	20'-04"	18'-06"	16'-07"	19'-09"	18'-00"	16'-01"	
		14"	22'-09"	20'-09"	18'-06"	22'-04"	20'-04"	18'-02"	21'-09"	19'-10"	17'-08"	
	WI 60	11⅞"	24'-01"	22'-03"	19'-11"	22'-10"	21'-05"	19'-06"	21'-03"	20'-00"	18'-06"	
		14"	26'-09"	24'-05"	20'-08"	26'-00"	23'-11"	21'-05"	24'-03"	22'-09"	20'-10"	
		16"	28'-10"	25'-11"	20'-08"	28'-03"	25'-10"	21'-06"	26'-11"	25'-01"	22'-05"	
	WI 80	11⅞"	26'-09"	25'-02"	22'-10"	25'-04"	23'-10"	22'-00"	23'-08"	22'-03"	20'-07"	
		14"	30'-06"	28'-07"	25'-00"	28'-10"	27'-01"	25'-01"	26'-11"	25'-03"	23'-05"	
		16"	33'-10"	31'-04"	25'-00"	32'-00"	30'-01"	25'-03"	29'-10"	28'-00"	23'-11"	
	Snow 115%	GPI 20	9½"	16'-08"	15'-08"	14'-03"	15'-11"	14'-11"	13'-10"	14'-10"	13'-11"	12'-11"
			11⅞"	19'-11"	18'-02"	16'-03"	19'-01"	17'-10"	15'-11"	17'-10"	16'-09"	15'-06"
			14"	21'-10"	19'-11"	16'-04"	21'-06"	19'-07"	17'-00"	20'-05"	19'-02"	17'-01"
GPI 40		9½"	17'-09"	16'-03"	14'-06"	16'-11"	15'-11"	14'-03"	15'-10"	14'-11"	13'-09"	
		11⅞"	20'-03"	18'-05"	16'-06"	19'-11"	18'-02"	16'-02"	19'-00"	17'-09"	15'-10"	
		14"	22'-02"	20'-03"	18'-01"	21'-10"	19'-11"	17'-09"	21'-04"	19'-05"	17'-04"	
GPI 65		11⅞"	23'-04"	21'-11"	18'-03"	22'-03"	20'-10"	19'-00"	20'-10"	19'-06"	18'-01"	
		14"	26'-07"	22'-10"	18'-03"	25'-04"	23'-10"	19'-00"	23'-08"	22'-03"	20'-07"	
		16"	27'-06"	22'-10"	18'-03"	28'-02"	23'-10"	19'-00"	26'-04"	24'-09"	21'-00"	
GPI 90		11⅞"	26'-09"	25'-01"	23'-02"	25'-07"	24'-00"	22'-02"	23'-11"	22'-05"	20'-09"	
		14"	30'-05"	28'-06"	23'-06"	29'-00"	27'-03"	23'-06"	27'-02"	25'-06"	22'-06"	
		16"	33'-08"	29'-06"	23'-06"	32'-02"	29'-05"	23'-06"	30'-01"	28'-01"	22'-06"	
WI 40		9½"	16'-09"	15'-03"	13'-07"	16'-05"	15'-00"	13'-05"	15'-10"	14'-08"	13'-01"	
		11⅞"	19'-01"	17'-05"	15'-06"	18'-09"	17'-01"	15'-03"	18'-04"	16'-08"	14'-11"	
		14"	20'-11"	19'-01"	17'-01"	20'-07"	18'-09"	16'-09"	20'-01"	18'-04"	16'-05"	
WI 60		11⅞"	22'-05"	20'-06"	17'-06"	21'-07"	20'-02"	18'-00"	20'-02"	18'-11"	17'-06"	
		14"	24'-08"	21'-11"	17'-06"	24'-03"	22'-01"	18'-02"	23'-00"	21'-07"	19'-03"	
		16"	26'-04"	21'-11"	17'-06"	26'-01"	22'-10"	18'-02"	25'-06"	23'-03"	19'-03"	
WI 80		11⅞"	25'-02"	23'-07"	19'-04"	24'-00"	22'-06"	20'-01"	22'-05"	21'-01"	19'-06"	
		14"	28'-08"	26'-06"	21'-02"	27'-04"	25'-08"	21'-06"	25'-06"	24'-00"	20'-06"	
		16"	31'-08"	26'-06"	21'-02"	30'-04"	26'-11"	21'-06"	28'-04"	25'-08"	20'-06"	

Roof Joist Maximum Spans – 125% (Non-Snow)

Refer to Notes on page 8.

Load (PSF)	Joist Series	Joist Depth	Slope of 4/12 or less			Slope of over 4/12 through 8/12			Slope of over 8/12 through 12/12			
			16" o.c.	19.2" o.c.	24" o.c.	16" o.c.	19.2" o.c.	24" o.c.	16" o.c.	19.2" o.c.	24" o.c.	
Non-Snow 125% Live 20 Dead 10	GPI 20	9½"	21'-10"	20'-06"	19'-00"	20'-07"	19'-04"	17'-11"	19'-11"	18'-09"	17'-04"	
		11⅝"	26'-03"	24'-08"	22'-10"	24'-09"	23'-03"	21'-06"	23'-11"	22'-06"	20'-10"	
		14"	30'-00"	28'-02"	26'-01"	28'-04"	26'-07"	24'-08"	27'-05"	25'-09"	23'-10"	
	GPI 40	9½"	23'-04"	21'-11"	20'-03"	22'-00"	20'-08"	19'-01"	21'-03"	20'-00"	18'-06"	
		11⅝"	27'-11"	26'-03"	24'-03"	26'-04"	24'-09"	22'-11"	25'-06"	23'-11"	22'-02"	
		14"	31'-08"	29'-09"	27'-07"	29'-11"	28'-01"	26'-00"	28'-11"	27'-02"	25'-03"	
	GPI 65	11⅝"	30'-07"	28'-08"	26'-07"	28'-10"	27'-01"	25'-01"	27'-11"	26'-03"	24'-04"	
		14"	34'-10"	32'-08"	30'-03"	32'-10"	30'-10"	28'-07"	31'-10"	29'-11"	27'-08"	
		16"	38'-08"	36'-04"	33'-08"	36'-06"	34'-04"	31'-09"	35'-04"	33'-03"	30'-09"	
	GPI 90	11⅝"	35'-01"	33'-00"	30'-06"	33'-02"	31'-01"	28'-10"	32'-01"	30'-02"	27'-11"	
		14"	39'-10"	37'-05"	34'-08"	37'-07"	35'-04"	32'-09"	36'-05"	34'-03"	31'-09"	
		16"	44'-02"	41'-05"	38'-05"	41'-08"	39'-02"	36'-03"	40'-04"	37'-11"	35'-02"	
	WI 40	9½"	23'-04"	21'-11"	20'-03"	22'-00"	20'-08"	19'-01"	21'-03"	20'-00"	18'-06"	
		11⅝"	27'-11"	26'-03"	23'-10"	26'-04"	24'-09"	22'-11"	25'-06"	23'-11"	22'-02"	
		14"	31'-08"	29'-04"	26'-03"	29'-11"	28'-01"	25'-07"	28'-11"	27'-02"	25'-03"	
	WI 60	11⅝"	29'-08"	27'-10"	25'-09"	28'-00"	26'-03"	24'-04"	27'-01"	25'-05"	23'-07"	
		14"	33'-09"	31'-09"	29'-05"	31'-10"	29'-11"	27'-09"	30'-10"	29'-00"	26'-10"	
		16"	37'-06"	35'-03"	32'-08"	35'-05"	33'-03"	30'-10"	34'-03"	32'-03"	29'-10"	
	WI 80	11⅝"	33'-00"	31'-00"	28'-08"	31'-01"	29'-03"	27'-01"	30'-02"	28'-04"	26'-03"	
		14"	37'-06"	35'-03"	32'-07"	35'-05"	33'-03"	30'-10"	34'-03"	32'-03"	29'-10"	
		16"	41'-07"	39'-01"	36'-02"	39'-03"	36'-11"	34'-02"	38'-00"	35'-09"	33'-01"	
	Non-Snow 125% Live 20 Dead 15	GPI 20	9½"	20'-08"	19'-05"	18'-00"	19'-05"	18'-03"	16'-11"	18'-07"	17'-05"	16'-02"
			11⅝"	24'-10"	23'-04"	21'-07"	23'-04"	21'-11"	20'-04"	22'-04"	20'-11"	19'-05"
			14"	28'-05"	26'-08"	24'-09"	26'-08"	25'-01"	23'-03"	25'-06"	24'-00"	22'-03"
GPI 40		9½"	22'-01"	20'-09"	19'-02"	20'-09"	19'-06"	18'-00"	19'-10"	18'-07"	17'-03"	
		11⅝"	26'-05"	24'-10"	23'-00"	24'-10"	23'-04"	21'-07"	23'-09"	22'-03"	20'-08"	
		14"	30'-00"	28'-02"	25'-08"	28'-02"	26'-06"	24'-06"	26'-11"	25'-04"	23'-06"	
GPI 65		11⅝"	28'-11"	27'-02"	25'-02"	27'-02"	25'-06"	23'-08"	26'-00"	24'-05"	22'-07"	
		14"	33'-00"	30'-11"	28'-08"	31'-00"	29'-01"	26'-11"	29'-07"	27'-10"	25'-09"	
		16"	36'-08"	34'-05"	31'-10"	34'-05"	32'-04"	29'-11"	32'-11"	30'-11"	28'-08"	
GPI 90		11⅝"	33'-03"	31'-02"	28'-11"	31'-03"	29'-04"	27'-02"	29'-10"	28'-01"	26'-00"	
		14"	37'-09"	35'-05"	32'-10"	35'-06"	33'-04"	30'-10"	33'-11"	31'-10"	29'-06"	
		16"	41'-09"	39'-03"	36'-04"	39'-03"	36'-11"	34'-02"	37'-07"	35'-03"	32'-08"	
WI 40		9½"	22'-01"	20'-09"	19'-02"	20'-09"	19'-06"	18'-00"	19'-10"	18'-07"	17'-03"	
		11⅝"	26'-05"	24'-08"	22'-00"	24'-10"	23'-04"	21'-04"	23'-09"	22'-03"	20'-08"	
		14"	29'-08"	27'-01"	24'-02"	28'-02"	26'-03"	23'-06"	26'-11"	25'-04"	23'-06"	
WI 60		11⅝"	28'-01"	26'-04"	24'-05"	26'-04"	24'-09"	22'-11"	25'-02"	23'-08"	21'-11"	
		14"	32'-00"	30'-00"	27'-10"	30'-00"	28'-03"	26'-02"	28'-09"	27'-00"	25'-00"	
		16"	35'-06"	33'-04"	30'-08"	33'-04"	31'-04"	29'-00"	31'-11"	30'-00"	27'-09"	
WI 80		11⅝"	31'-03"	29'-04"	27'-02"	29'-04"	27'-07"	25'-06"	28'-01"	26'-04"	24'-05"	
		14"	35'-06"	33'-04"	30'-10"	33'-04"	31'-04"	29'-00"	31'-11"	30'-00"	27'-09"	
		16"	39'-05"	37'-00"	34'-03"	37'-00"	34'-09"	32'-02"	35'-05"	33'-03"	30'-10"	
Non-Snow 125% Live 20 Dead 20		GPI 20	9½"	19'-09"	18'-06"	17'-02"	18'-06"	17'-04"	16'-01"	17'-06"	16'-05"	15'-03"
			11⅝"	23'-08"	22'-03"	20'-07"	22'-02"	20'-10"	19'-04"	21'-00"	19'-09"	18'-03"
			14"	27'-01"	25'-06"	23'-07"	25'-05"	23'-10"	22'-01"	24'-00"	22'-07"	20'-11"
	GPI 40	9½"	21'-00"	19'-09"	18'-03"	19'-08"	18'-06"	17'-02"	18'-08"	17'-06"	16'-03"	
		11⅝"	25'-02"	23'-08"	21'-10"	23'-07"	22'-02"	20'-06"	22'-04"	21'-00"	19'-05"	
		14"	28'-08"	26'-09"	23'-11"	26'-10"	25'-02"	23'-01"	25'-05"	23'-10"	22'-01"	
	GPI 65	11⅝"	27'-07"	25'-11"	24'-00"	25'-10"	24'-03"	22'-06"	24'-06"	23'-00"	21'-04"	
		14"	31'-05"	29'-06"	27'-04"	29'-05"	27'-08"	25'-07"	27'-11"	26'-03"	24'-03"	
		16"	34'-11"	32'-10"	30'-05"	32'-09"	30'-09"	28'-06"	31'-00"	29'-02"	27'-00"	
	GPI 90	11⅝"	31'-08"	29'-09"	27'-06"	29'-08"	27'-11"	25'-10"	28'-02"	26'-05"	24'-06"	
		14"	36'-00"	33'-10"	31'-03"	33'-09"	31'-08"	29'-04"	32'-00"	30'-00"	27'-10"	
		16"	39'-10"	37'-05"	34'-08"	37'-04"	35'-01"	32'-06"	35'-05"	33'-03"	30'-09"	
	WI 40	9½"	21'-00"	19'-09"	18'-00"	19'-08"	18'-06"	17'-02"	18'-08"	17'-06"	16'-03"	
		11⅝"	25'-02"	23'-00"	20'-07"	23'-07"	22'-02"	19'-10"	22'-04"	21'-00"	19'-05"	
		14"	27'-08"	25'-03"	22'-07"	26'-09"	24'-05"	21'-10"	25'-05"	23'-10"	21'-09"	
	WI 60	11⅝"	26'-09"	25'-02"	23'-03"	25'-01"	23'-07"	21'-10"	23'-09"	22'-04"	20'-08"	
		14"	30'-06"	28'-08"	26'-06"	28'-07"	26'-10"	24'-10"	27'-01"	25'-05"	23'-07"	
		16"	33'-11"	31'-10"	28'-07"	31'-09"	29'-10"	27'-07"	30'-01"	28'-03"	26'-02"	
	WI 80	11⅝"	29'-09"	27'-11"	25'-10"	27'-11"	26'-02"	24'-03"	26'-05"	24'-10"	23'-00"	
		14"	33'-10"	31'-10"	29'-05"	31'-09"	29'-10"	27'-07"	30'-01"	28'-03"	26'-02"	
		16"	37'-07"	35'-03"	32'-08"	35'-02"	33'-01"	30'-07"	33'-04"	31'-04"	29'-00"	

Dead Load Material Weights

Pounds per square foot (PSF)

Material	PSF	Material	PSF	Material	PSF
Sheathing and Decking		Roofing		2x Framing (12" o.c.)	
1 1/2" Plytanium® Plywood	1.1	2-15 lb. and 1-90 lb. rolled	1.7	2x4 (for 16" o.c. divide by 1.33)	1.4
1 5/8" Plytanium Plywood	1.5	3-15 lb. and 1-90 lb. rolled	2.2	2x6 (for 16" o.c. divide by 1.33)	2.2
1 7/8" Plytanium Plywood	1.8	3-ply and gravel	5.5	2x8 (for 16" o.c. divide by 1.33)	2.9
2 3/8" Plytanium Plywood	2.2	4-ply and gravel	6.0	2x10 (for 16" o.c. divide by 1.33)	3.7
7/8" Plytanium Plywood	2.6	5-ply and gravel	6.5	2x12 (for 16" o.c. divide by 1.33)	4.4
1 1/8" Plytanium Plywood	3.4	Single-ply membrane	2.0	GPI (for 19.2" o.c. divide by 1.6)	2.3–4.8
3/8" OSB	1.3	and gravel	5.5	WI (for 19.2" o.c. divide by 1.6)	2.6–4.5
7/16" OSB	1.5	Asphalt shingles	2.5	See page 29 for weight per lineal foot	
1/2" OSB	1.7	Tough-Glass®	2.1	Interior Walls (wood or steel studs)	
1 9/32" OSB	2.0	Tough-Glass® Plus	2.4	5/8" gypsum board each side	8.0
2 3/32" OSB	2.6	Summit®	2.5	5/8" gypsum board one side plaster one side	12.0
1x decking	2.3	Summit® III	3.0	Plaster both sides	
2x decking	4.3	Wood shingles	3.0	Exterior Walls (2x6 studs with insulation)	
3x decking	7.0	Asbestos-cement shingles	4.0	5/8" gypsum board and wood siding	10.0
18 gage metal deck	3.0	Clay tile (minimum)	10.0	5/8" gypsum board and cement siding	12.0
20 gage metal deck	2.5	Concrete tile (Monier®)	9.5	5/8" gypsum board and stucco	18.0
Ceilings		Spanish tile	19.0	Windows, glass, frame and sash	8.0
1/2" gypsum board	2.2	Floor Finish		5/8" gypsum board and brick veneer	48.0
5/8" gypsum board	2.8	Hardwood (nominal 1")	4.0	Note: Wall weights are per square foot of wall	
Metal suspension system w/acoustical tile	1.8	Carpet and pad	2.0	Multiply weight times wall height for plf.	
Wood suspension system w/acoustical tile	2.5	Linoleum or soft tile	1.5	Insulation (per 1" thickness)	
1" plaster with lath	8.0	3/4" ceramic or quarry tile (w/out mortar)	10.0	Rigid	1.5
Miscellaneous		1/2" mortar bed	6.0	Batts	0.5
Mechanical ducts	2.0-4.0	1" mortar bed	12.0	1.0-2.0 PSF is recommended for miscellaneous dead loads.	
Skylight, metal frame 3/8" glass	8.0	Floor Fill			
Stucco	10.0	1 1/2" lightweight concrete	14.0		
		1 1/2" regular concrete	18.0		
		3/4" GYP-CRETE	6.5		

General Notes and Information for Allowable Uniform Loads – Floor and Roof (use these general notes for pages 12-13)

- Table values are based on: (a) clear distance between supports, (b) simple or multiple spans, (c) spans of multiple span joists at least 40% of adjacent span.
- Uniform loads shown below cover a broad range of applications. It may be possible to exceed these loads by analyzing a specific application using FASTBeam® software. For cases with cantilevers or point loads, use FASTBeam software or contact Georgia-Pacific.
- Both live and total loads must be checked—live load against the Live row and total load against the Total row. When no value is shown in the Live row, total load will govern.
- Verify that the deflection criteria herein are accepted by local codes and authorities.
- Provide lateral support at bearing points and continuous lateral support along the compression flange of each joist.
- Minimum end bearing length is 1 1/4". Minimum intermediate bearing length is 3/4".
- For double joists, double the table values and connect joists per detail F11.
- For proper installation procedures, refer to appropriate sections in this publication.
- Table does not include additional stiffness from composite action with glue-nailed or nailed decking.

PSF to PLF Conversion

Load in pounds per lineal foot (PLF)

O.C. Spacing	Spacing Factor	Load in pounds per square foot (PSF)											
		20	25	30	35	40	45	50	55	60	65	70	75
12"	1.00	20	25	30	35	40	45	50	55	60	65	70	75
16"	1.33	27	34	40	47	54	60	67	74	80	87	94	100
19.2"	1.60	32	40	48	56	64	72	80	88	96	104	112	120
24"	2.00	40	50	60	70	80	90	100	110	120	130	140	150

Calculating Uniform Loads (Plan View)

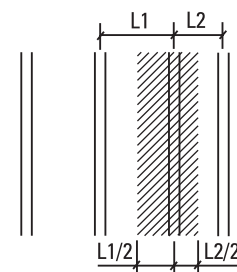

Joist Spacing (L1, L2)

$$\left(\frac{L1(ft.)}{2} + \frac{L2(ft.)}{2} \right) \times LL(psf) = LL(plf)$$

$$\left(\frac{L1(ft.)}{2} + \frac{L2(ft.)}{2} \right) \times TL(psf) = TL(plf)$$

Check resulting loads against those in the appropriate table.

Allowable Uniform Floor Loads (PLF)

Joist Series	Depth	Joist Span:	6'	7'	8'	9'	10'	11'	12'	13'	14'	15'	16'	17'	18'	19'	20'	21'	22'	23'	24'	25'	26'	27'	28'	29'	30'	
GPI 20	9 1/2"	Live L/600			208	153	116	90	71	57	46	38	32	26	22													
		L/480				192	145	112	88	71	57	47	39	33	28													
	Total L/240	301	259	227	202	182	165	152	137	115	95	79	66	56														
	11 1/8"	Live L/600						148	117	94	77	64	53	45	38	33	28	24	21	19								
		L/480							146	118	96	79	66	56	48	41	35	31	27	24								
	Total L/240	301	259	228	203	183	167	153	142	132	123	115	104	93	82	70	61	53	47									
14"	Live L/600									136	112	93	77	65	56	48	41	36	32	28	25	22	19	17				
	L/480										116	97	82	70	60	52	45	39	35	31	27	24	22					
Total L/240	301	259	228	203	183	167	153	142	132	123	115	109	103	97	91	82	75	69	61	55	49	44						
GPI 40	9 1/2"	Live L/600				180	137	106	84	67	55	45	38	32	27													
		L/480					171	133	105	84	69	57	47	40	34													
	Total L/240	321	275	240	214	192	175	160	141	122	107	94	79	68														
	11 1/8"	Live L/600						172	137	111	91	75	63	53	45	39	34	29	26	22								
		L/480								139	113	94	79	66	56	48	42	36	32	28								
	Total L/240	334	288	253	226	204	185	170	157	146	137	121	108	96	86	78	71	64	56									
14"	Live L/600									129	107	90	76	65	56	48	42	37	32	29	26	23	20					
	L/480										134	112	95	81	70	60	52	46	41	36	32	28	26					
Total L/240	334	288	253	226	204	185	170	157	146	137	128	121	114	104	94	85	78	71	65	60	56	51						
GPI 65	11 1/8"	Live L/600								140	115	95	80	68	58	50	43	38	33	29								
		L/480									143	119	100	85	72	62	54	47	41	36								
	Total L/240	336	289	254	226	204	186	171	158	147	137	129	121	115	109	103	94	82	73									
	14"	Live L/600										136	115	97	83	72	62	54	48	42	37	33	30	27				
		L/480											104	90	78	68	60	53	47	42	37	33						
	Total L/240	336	289	254	226	204	186	171	158	147	137	129	121	115	109	103	98	94	90	86	83	74	67					
16"	Live L/600														111	96	84	73	64	57	51	45	40	36	33	30	27	
	L/480															92	80	71	63	56	50	45	41	37	33			
Total L/240	336	289	254	226	204	186	171	158	147	137	129	121	115	109	103	98	94	90	86	83	80	77	74	71	67			
GPI 90	11 1/8"	Live L/600								194	162	135	115	98	84	72	63	55	48	43								
		L/480										169	143	122	105	91	79	69	61	54								
	Total L/240	432	372	327	291	263	239	220	203	189	176	165	156	147	140	133	126	121	107									
	14"	Live L/600											160	137	118	102	89	78	69	61	54	49	43	39				
		L/480												128	112	98	86	76	68	61	54	49						
	Total L/240	432	372	327	291	263	239	220	203	189	176	165	156	147	140	133	126	121	116	111	106	102	98					
16"	Live L/600															135	118	103	91	81	72	64	58	52	47	43	39	
	L/480																114	101	90	81	72	65	59	53	49			
Total L/240	432	372	327	291	263	239	220	203	189	176	165	156	147	140	133	126	121	116	111	106	102	99	95	92	89			
WI 40	9 1/2"	Live L/600				180	137	106	84	67	55	45	38	32	27													
		L/480					133	105	84	69	57	47	40	34														
	Total L/240	278	239	210	187	169	154	141	125	108	94	83	74	66														
	11 1/8"	Live L/600						172	137	111	91	75	63	53	45	39	34	29	26	22								
		L/480							139	113	94	79	66	56	48	42	36	32	28									
	Total L/240	322	277	243	217	196	178	164	151	140	122	108	96	85	77	69	63	57	53									
14"	Live L/600									129	107	90	76	65	56	48	42	37	32	29	26	23	20					
	L/480										112	95	81	70	60	52	46	41	36	32	28	26						
Total L/240	322	277	243	217	196	178	164	151	141	131	123	115	103	92	84	76	69	63	58	54	50	46						
WI 60	11 1/8"	Live L/600							160	129	106	88	74	63	53	46	40	35	30	27								
		L/480								133	110	92	78	67	57	50	43	38	33									
	Total L/240	322	277	243	217	196	178	164	151	141	131	123	116	110	104	96	86	76	67									
	14"	Live L/600									126	106	90	77	66	57	50	44	39	34	31	27	25					
		L/480										112	96	83	72	63	55	48	43	38	34	31						
	Total L/240	322	277	243	217	196	178	164	151	141	131	123	116	110	104	99	94	90	86	80	74	68	61					
16"	Live L/600														103	89	77	67	59	52	46	41	37	33	30	27	25	
	L/480															96	84	74	65	58	52	46	41	37	33	30	27	
Total L/240	322	277	243	217	196	178	164	151	141	131	123	116	110	104	99	94	90	86	83	79	76	73	69	64	60			
WI 80	11 1/8"	Live L/600									139	116	98	83	71	61	53	47	41	36								
		L/480										122	104	89	77	67	58	51	45									
	Total L/240	355	306	269	240	216	197	181	167	155	145	136	128	121	115	109	104	99	90									
	14"	Live L/600											138	118	101	88	76	67	59	52	46	41	37	33				
		L/480												127	109	95	83	73	65	58	51	46	41					
	Total L/240	389	335	294	262	236	215	198	183	170	159	149	140	133	126	119	114	109	104	100	96	92	83					
16"	Live L/600															116	101	89	78	69	62	55	49	44	40	36	33	
	L/480																111	98	87	77	69	62	55	50	45	41		
Total L/240	389	335	294	262	236	215	198	183	170	159	149	140	133	126	119	114	109	104	100	96	92	89	86	83	80			

NOTES:

1. Refer to General Notes on page 11.
2. L/480 live load deflection is recommended (See System Performance on page 5.) For L/360 (minimum code deflection) multiply L/480 value times 1.33.
3. Total load deflection is limited to L/240.

Allowable Uniform Roof Loads (PLF)

Joist Series	Depth	Joist Span:	6'	7'	8'	9'	10'	11'	12'	13'	14'	15'	16'	17'	18'	19'	20'	21'	22'	23'	24'	25'	26'	27'	28'	29'	30'		
GPI 20	9 1/2"	Live L/240							177	141	115	95	79	66	56	48	41	36	31	28	24								
		Total	115%	346	298	262	232	209	190	174	158	137	119	105	88	75	64	55	48	42	37	33							
	11 1/8"	Live L/240												133	112	95	82	70	61	53	47	42	37	33	29	27	24		
		Total	115%	346	298	262	234	211	192	176	163	151	141	133	120	107	96	87	79	71	63	55	49	44	39	35	32		
	14"	Live L/240												120	104	90	79	69	61	55	49	44	39	35	32				
		Total	115%	346	298	262	234	211	192	176	163	151	141	133	125	118	112	104	95	86	79	73	67	62	58	52	47	43	
GPI 40	9 1/2"	Live L/240											168	137	113	94	79	68	58	50	43	38	33	29	26	23			
		Total	115%	369	316	277	246	221	201	184	163	141	123	108	96	86	77	67	58	51	44	39	35	31					
	11 1/8"	Live L/240												133	113	97	84	73	64	56	50	44	39	35	32	29	26		
		Total	115%	385	331	291	259	234	213	196	181	168	157	140	124	111	99	90	82	74	68	63	58	53	47	42	38	35	
	14"	Live L/240												105	92	81	72	64	57	51	46	41	37	34					
		Total	115%	385	331	291	259	234	213	196	181	168	157	147	139	131	119	108	98	89	82	75	69	64	59	55	52	48	
GPI 65	11 1/8"	Live L/240																		105	94	83	74	67	60	54	49		
		Total	115%	386	333	292	260	235	214	197	182	169	158	148	139	132	125	119	113	108	97	86	76	68	61	55	50	45	
	14"	Live L/240												125	108	94	82	73	64	57	51	46	41	37	34				
		Total	115%	386	333	292	260	235	214	197	182	169	158	148	139	132	125	119	113	108	97	86	76	68	61	55	50	45	
	16"	Live L/240												129	123	117	112	108	103	99	95	92	88	85	82	79			
		Total	115%	386	333	292	260	235	214	197	182	169	158	148	139	132	125	119	113	108	103	99	95	92	88	85	82	79	
GPI 90	11 1/8"	Live L/240																											
		Total	115%	496	428	376	335	302	275	253	234	217	203	190	179	169	161	153	145	139	133	127	113	101	91	82	74	67	
	14"	Live L/240																											
		Total	115%	496	428	376	335	302	275	253	234	217	203	190	179	169	161	153	145	139	133	127	113	101	91	82	74	67	
	16"	Live L/240																											
		Total	115%	496	428	376	335	302	275	253	234	217	203	190	179	169	161	153	145	139	133	127	113	101	91	82	74	67	
WI 40	9 1/2"	Live L/240																											
		Total	115%	320	275	242	216	194	177	163	144	124	109	96	85	76	68	62	56	51	44	39	35	31					
	11 1/8"	Live L/240																											
		Total	115%	370	319	280	249	225	205	188	174	161	141	124	110	98	88	80	72	66	60	56	51	47	44	41	38	35	
	14"	Live L/240																											
		Total	115%	370	319	280	249	225	205	188	174	162	151	142	132	118	106	96	87	80	73	67	62	57	53	49	46	43	
WI 60	11 1/8"	Live L/240																											
		Total	115%	370	319	280	249	225	205	188	174	162	151	142	134	126	120	110	100	91	84	77	70	63	56	50	46	41	
	14"	Live L/240																											
		Total	115%	370	319	280	249	225	205	188	174	162	151	142	134	126	120	114	108	104	99	92	85	79	73	68	64	59	
	16"	Live L/240																											
		Total	115%	370	319	280	249	225	205	188	174	162	151	142	134	126	120	114	108	104	99	95	91	88	85	79	74	69	
WI 80	11 1/8"	Live L/240																											
		Total	115%	408	352	309	275	248	226	208	192	179	167	157	147	139	132	126	120	114	109	105	95	85	76	69	62	56	
	14"	Live L/240																											
		Total	115%	447	385	338	301	272	248	227	210	195	183	171	161	153	145	137	131	125	120	115	110	106	102	97	90	81	
	16"	Live L/240																											
		Total	115%	447	385	338	301	272	248	227	210	195	183	171	161	153	145	137	131	125	120	115	110	106	102	98	95	92	

NOTES:

1. Refer to General Notes on page 11.
2. All roof joists to be sloped 1/4" in 12" minimum.
3. Use of this table for horizontal spans should be limited to roof slopes of 2" per foot or less. For greater slopes, convert horizontal span to up-the-slope span using the table on page 14.
4. Total load deflection is limited to L/180. For less deflection use the L/240 row.
5. Table applies to gravity loads only.

Up-the-Slope Spans & Cutting Lengths for Sloped Roofs

Slope	Slope Factor	Joist Depth			
		9 1/2"	11 1/8"	14"	16"
Amount to Increase Length for Plumb Cut (Lp in feet)					
2 1/2 in 12	1.021	0.165	0.206	0.243	0.278
3 in 12	1.031	0.198	0.247	0.292	0.333
3 1/2 in 12	1.042	0.231	0.289	0.340	0.389
4 in 12	1.054	0.264	0.330	0.389	0.444
4 1/2 in 12	1.068	0.297	0.371	0.438	0.500
5 in 12	1.083	0.330	0.412	0.486	0.556
6 in 12	1.118	0.396	0.495	0.583	0.667
7 in 12	1.158	0.462	0.577	0.681	0.778
8 in 12	1.202	0.528	0.660	0.778	0.889
9 in 12	1.250	0.594	0.742	0.875	1.000
10 in 12	1.302	0.660	0.825	0.972	1.111
11 in 12	1.357	0.726	0.907	1.069	1.222
12 in 12	1.414	0.792	0.990	1.167	1.333

When using the uniform load table for roofs with slopes greater than 2" per foot, substitute the up-the-slope-span in the table on page 13.

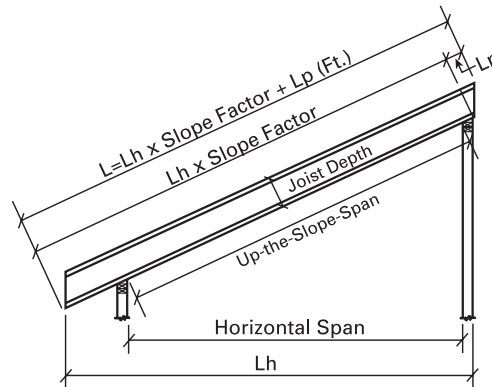

EXAMPLE:

7/12 slope and 20'-0" horizontal span, 2'-0" overhang (horizontal) one end, 2x4 walls
 Up-the-slope span: 20' x 1.158 = 23.16' — use 24' joist span column to check load capacity.

Overall length: $L_h = 2' + 3.5"/12 + 20' + 3.5"/12 = 22.583'$
 If a 14" joist will be used, $L_p = 0.681$ feet
 $L = (22.583' \times 1.158) + 0.681' = 26.832' = 26'-10"$

Storage and Handling

- Wood I Beam™ joists and FiberStrong® rim board should not be stored in direct contact with the ground and should be protected from weather. Provide air circulation under covering and around stacks of materials.
- Bundles should be stored level.
- Do not open bundles until time of installation. Use care when handling bundles and individual components to prevent injury to handlers or damage by forklifts or cranes.
- Stack and handle Wood I Beam joists in the upright position. Stack and handle FiberStrong rim board flatwise.
- Twisting of joists, or applying loads to the joist when flat can damage the joist.
- Damaged products should not be used.

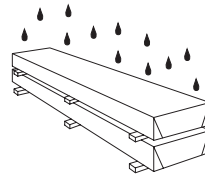

Protect products from sun and water. Use support blocks at 10' on-center to keep bundles out of water.

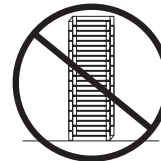

DO NOT store Wood I Beam joists flat.



DO NOT lift Wood I Beam joists by top flange.

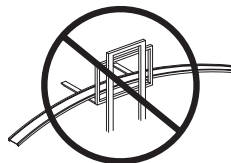

DO NOT lift Wood I Beam joists in the flat orientation.

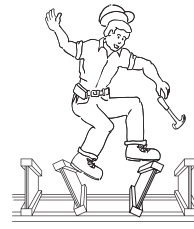

Do not allow workers or loads on Wood I Beam joists until properly installed and braced.

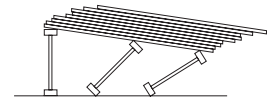

Stack building materials over main beams or walls only—NOT on unsheathed joists.

Safety Warning

Handlers and installers should use appropriate personal protective equipment such as gloves and goggles. An MSDS is available at www.gp.com/build.

Wood I Beam joists will not support workers or other loads until properly installed and braced. To minimize risk of injury, each Wood I Beam joist shall be properly fastened as it is erected. Continuous closure and/or blocking panels must be installed and attached to joists prior to installing floor or roof sheathing. Lateral restraint, such as an existing deck or braced end wall, must be established at the ends of the bay. Alternatively, a temporary or permanent deck (sheathing) may be nailed to the first 4 feet of joists at the end of the bay.

Rows of temporary bracing at right angles to joists

must be fastened with a minimum of two 8d nails (10d box nails if net thickness of bracing exceeds 1") to the upper surface of each parallel joist and the established lateral restraint. Bracing should be 1x4 minimum and at least 8' long with on-center spacing not to exceed 10'. Ends of adjoining bracing should lap over at least two joists. Stack building materials over main beams or walls only.

The following can result in serious accidents: improper storage or installation, failure to follow applicable building codes, failure to follow proper load tables, failure to use acceptable hole sizes and locations, or failure to use bearing stiffeners when required. Installation notes must be followed carefully.

Installation Notes

- A. Engineered lumber must not be installed in direct contact with concrete or masonry construction per code and shall be used in covered, dry-use conditions only (moisture content less than 16%).
- B. Except for cutting to length and birdsmouth cuts, top and bottom flanges of Wood I Beam™ joists shall not be cut, drilled or notched.
- C. Concentrated loads shall only be applied to the upper surface of the top flange, not suspended from the bottom flange. Contact Georgia-Pacific for exceptions.
- D. When nailing to the wide face of the flange surface, maintain spacing in the ranges shown below:

Nail Size	Flange Nail Spacing					
	GPI 20		GPI 40, GPI 65, GPI 90		WI 40, WI 60, WI 80	
	Min.	Max.	Min.	Max.	Min.	Max.
8d Box, 8d Common	3"	16"	2"	24"	4"	24"
10d Box, 12d Box	3"	16"	2"	24"	4"	24"
10d Common, 12d Common	4½"	16"	3"	24"	4"	24"

NOTES:

1. If more than one row of nails is required, rows must be offset by at least ½" (¾" for WI joists) and staggered.
2. 14 gauge staples may be substituted for 8d nails if staples penetrate the joist flange at least 1".
3. Do not use nails larger than those shown above when attaching sheathing to flanges of Wood I Beam joists.

Example: When using 8d common nails and GPI 20 series joists, space no closer (min.) than 3" o.c. and no farther (max.) than 16" o.c.

- E. End bearing length must be at least 1¾". Intermediate bearings of multiple span joists must be at least 3½".
- F. Wood I Beam joists must be supported on walls, beams, or in hangers. They may not be supported by a non-structural ridge board or by toe-nailing into a beam or ledger.

- G. Wood I Beam joists must be restrained against rotation at the ends of joists by use of rim joists, blocking panels, or cross bridging. To laterally restrain cantilevered joists, blocking panels must also be installed over supports nearest the cantilever. The top flange of a Wood I Beam joist must be laterally supported and kept straight within ½" of true alignment. Plytanium® Plywood or OSB sub-floor nailed to the top flange (per Note D) is adequate to provide lateral support.

- H. When nail type is not specified in this guide, use common, box or sinker.

- I. To help safeguard the structural integrity of connections with preservative or fire-retardant treated wood, use only hot-dipped galvanized or stainless steel fasteners, connectors and hardware, as required by code and type of treatment.

As a minimum requirement, hot-dipped galvanized coated fasteners should conform to ASTM Standard A 153 and hot-dipped galvanized coated connectors should conform to ASTM Standard A 653 (Class G-185). In demanding applications, or in highly corrosive environments, stainless steel fasteners and connectors should be utilized and may, in fact, be required by building codes.

Most commonly available electroplated galvanized fasteners do not have a sufficient coating of zinc and are not recommended. Aluminum should not be used in direct contact with preservative treated wood. Never mix galvanized steel with stainless steel in the same connection.

- J. Certain applications of staple-up radiant heating may cause additional deflection in I-joists with solid-sawn flanges due to unequal drying within the floor cavity. Contact Georgia-Pacific for additional information.

- K. Wood I Beam joists are manufactured without camber or specific vertical orientation. They may be installed with the identifying stamps on the side faces reading right side up or upside down.

Common Installation Errors

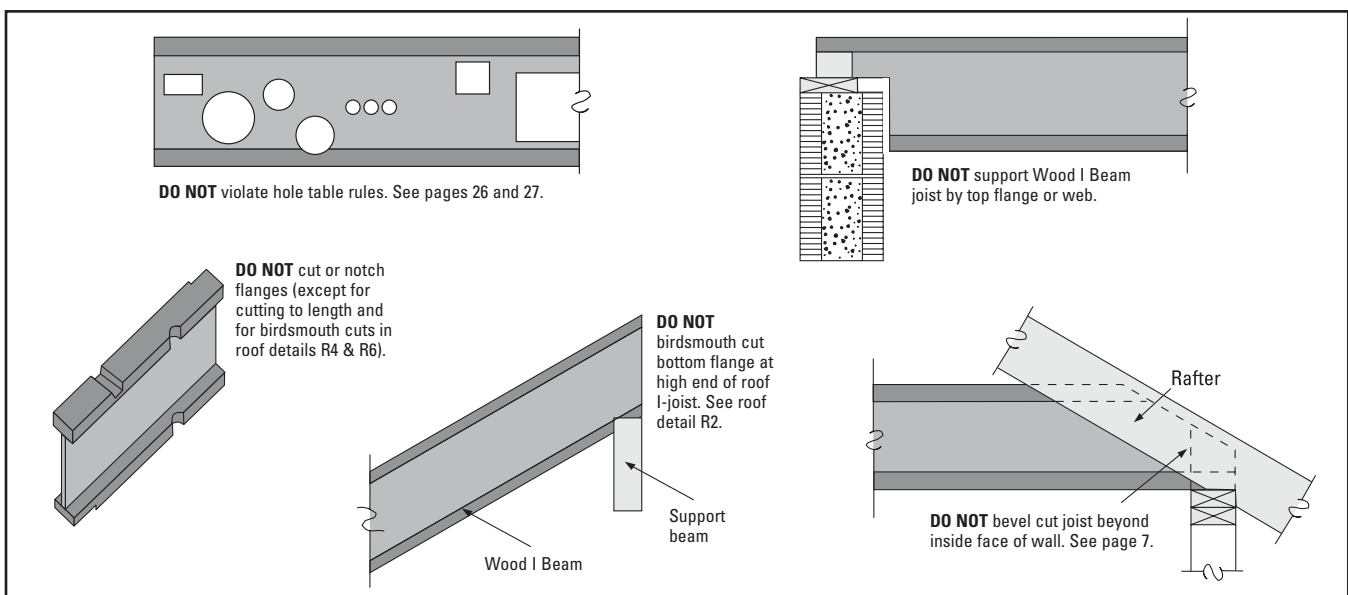

Fire Rated Assemblies*

Building codes for apartments and multi-family homes commonly require floor, ceiling or even roof framing assemblies that have a fire-resistant rating in accordance with standard ASTM fire tests. Wood I-joists along with conventional lumber and other framing materials provide the structural support, and the fire rated assemblies provide the fire-resistant rating. For these fire-rated assemblies, Wood I Beam™ joists are acceptable for use as noted in the table below. Several widely used “generic” assemblies are provided in “Design for Code Acceptance 3” (DCA 3), an American Wood Council (AWC) publication. Most of these details have also been adopted by the International Building Code (IBC) as contained in Table 720.1(3) of the

Duration	2006 IBC Table 720.1(3)	AWC DCA 3	APA ICC-ES Report ESR-1405	Wood I Beam Joists that meet the requirements
1 Hr.	Item 21-1.1	–	Assembly 2	All GPI and WI series
1 Hr.	Item 23-1.1	WIJ-1.3	–	All GPI and WI series
1 Hr.	Item 25-1.1	WIJ-1.1	–	GPI 90 and WI 80
1 Hr.	Item 26-1.1	WIJ-1.2	–	16” GPI 90
1 Hr.	Item 27-1.1	WIJ-1.5	–	GPI 90, WI 40, WI 60 and WI 80
1 Hr.	Item 28-1.1	WIJ-1.6	–	All GPI and WI series
1 Hr.	–	–	Assembly 1	GPI 90, WI 40, WI 60 and WI 80
1 Hr.	–	–	Assembly 3	All GPI and WI series
2 Hr.	Item 29-1.1	WIJ-2.1	–	GPI 90, WI 40, WI 60 and WI 80

For additional resources, please see the following:

AWC: DCA 3 (www.awc.org/Publications/)

APA: The Engineered Wood Association (www.apawood.org/publications)
ICC ES Report ESR-1405
Form No. W305 for I-joists
Form No. D350 for Rim Board

GPI: ICC-ES Reports ESR-1325 & NER-707 (www.icc-es.org/reports/pdf_files/)
www.gp.com/safetyinfo

GA: Gypsum Association (www.gypsum.org)

IBC: International Building Code (www.iccsafe.org)

2006 IBC. Several of the details and similar assemblies are provided in the Gypsum Association’s Fire Resistance Design Manual (GA-600-2006). Assemblies specific to GPI and WI Series I-joists appear in ICC-ES reports ESR-1325 and NER-707, respectively.

Additional “generic” assemblies appear in various APA publications and in the APA ICC-ES code report ESR-1405. Instead of being specific to a single manufacturer, “generic” assemblies are generally dependent on the product dimensions for wood I-joists, and the product grades for gypsum board. All Wood I Beam (GPI and WI) series in this guide can be used in the following common assembly (WIJ-1.6 from DCA 3).

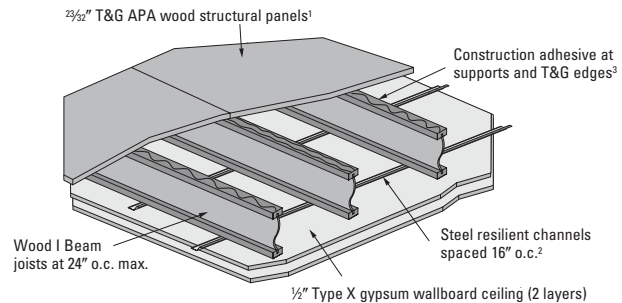

- Paragraph 13 of the UL Fire Resistance Directory indicates wood structural panels include all-veneer plywood, composite panels, and mat-formed (OSB) panels bearing a PS 1 or PS 2 standard label, or labeled to meet APA Standard PRP-108 or PFS Standard PRP-133. Substitution is based on equivalent panel thickness.
- For improved acoustical performance, gypsum wallboard is fastened to steel resilient furring channels in some assemblies.
- Construction adhesive must conform to APA Specification AFG-01, or ASTM D 3498.

* Although most residential structures (detached one- and two-family dwellings) do not require fire-resistance-rated assemblies, the inclusion of a protective membrane such as gypsum board can improve fire performance. Passing a fire test in a controlled laboratory setting and referring to an assembly as having a one-hour, two-hour, or any other fire resistance or protection rating does not mean that either the particular assembly/system will necessarily provide one-hour fire resistance, two-hour fire resistance, or any other specified fire resistance or protection in an actual fire. In the event of an actual fire, you should immediately take any and all actions necessary for your safety and the safety of others without regard for any fire rating of any assembly/system. For additional information please visit www.gp.com/safetyinfo.

Noise Rated Assemblies

Building codes may also require that framing assemblies meet certain noise ratings. The assembly is typically rated for both noise transmission types—airborne (sound transmission class or STC number) and impact (impact insulation class or IIC number). The higher the number, the better the noise control. For reference, an STC rating of 25 would allow normal speech to be heard quite clearly, while an STC of 50 would limit loud speech to an inaudible range.

All Wood I Beam joist series in this guide can be used in the noise rated assembly shown here. Many more noise rated assemblies are in the AWC, APA, and Gypsum Association references listed in the section above. Further general information on noise rated assemblies is given in APA Form No. W460 (www.apawood.org/publications).

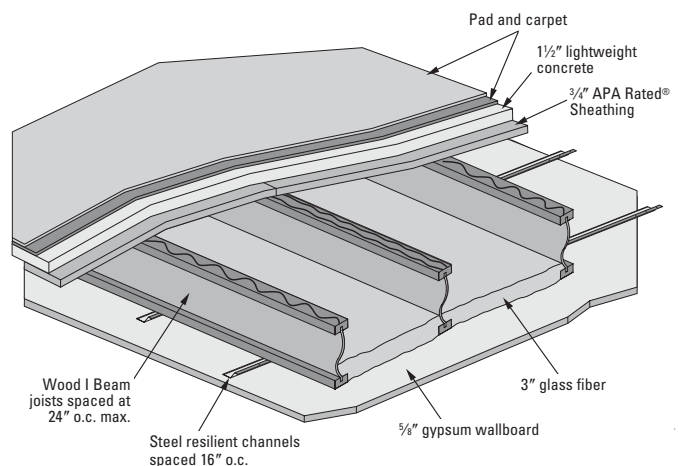

Test Sponsor and Number ¹	Finish Floor	Deck	Gypsum Wallboard Ceiling	Insulation	STC Rating	IIC Rating	Weight (lbs./sq. ft.)
G&H USDA 11 ST	Vinyl or Tile	1½” of 100-pcf cellular concrete over ¾” APA Rated® Sheathing subfloor on I-joists at 24” o.c.	5/8” screwed to steel resilient channels	3” glass fiber	58	50	21.0
G&H USDA 11x ST	Carpet & Pad			None	57	None	
	None						

1. USDA Forest Service Wood Construction Research (Seattle, WA); acoustical tests by Geiger & Hamme, Inc. (Ann Arbor, MI).

Typical Framing

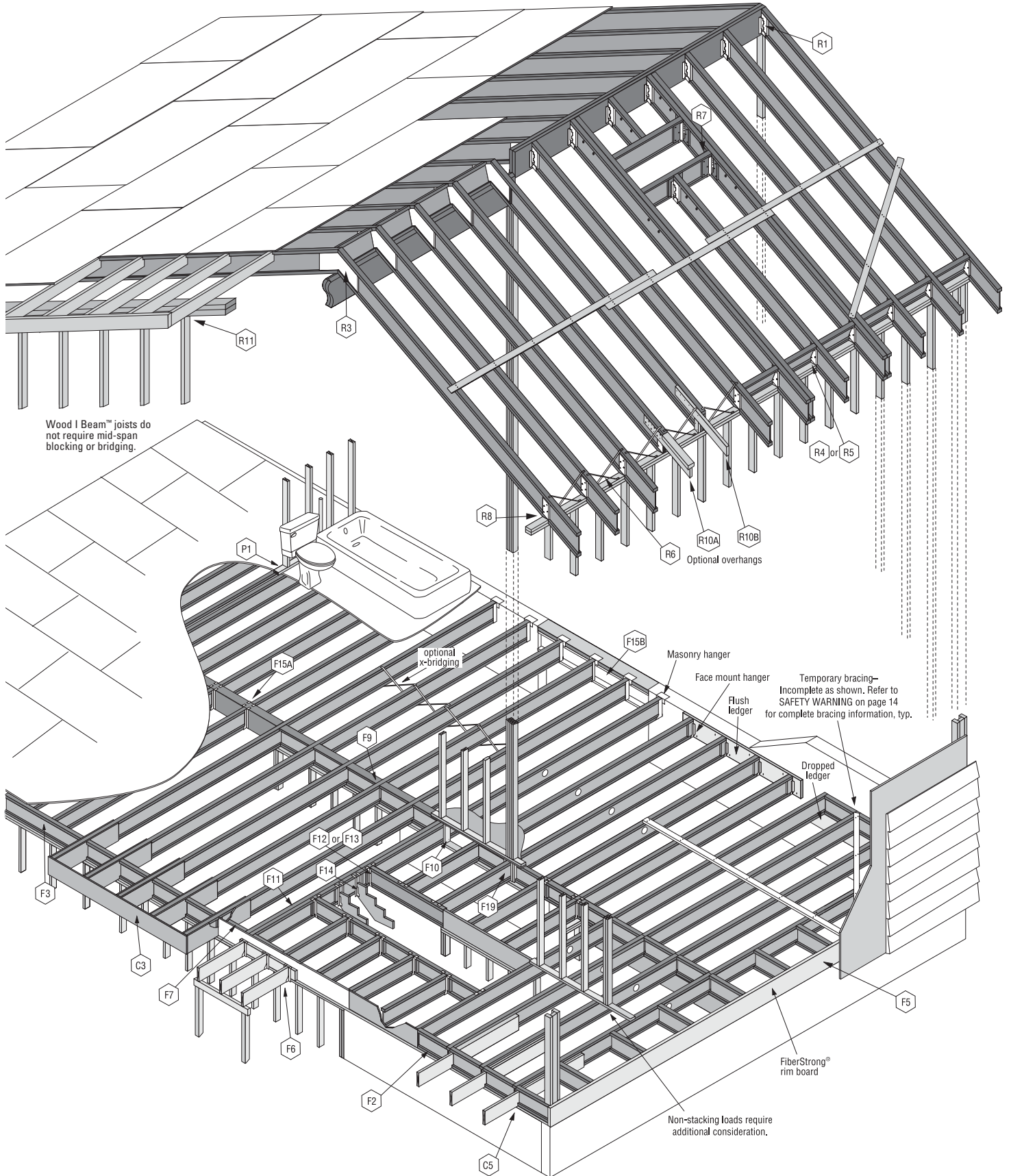

Floor Details

F1 ATTACHMENT AT END BEARING

One 10d box or sinker nail each side at bearing, typical for all wood bearings

1 3/4" minimum end bearing length at all floor and roof details

To minimize splitting of flange and bearing plate, angle nails and start at least 1 1/2" from end.

F2 BLOCKING PANEL, EXTERIOR
Vertical load transfer = 2000 plf max.

Wood I Beam™ blocking panel

8d nails at 6" o.c.
Note: For shear transfer, use same nailing as required for sheathing, but complying with Installation Note D, page 15.

F3 WOOD I BEAM™ RIM JOIST
Vertical load transfer = 2000 plf max.

Wood I Beam rim joist

Provide backer for siding attachment unless nailable sheathing is used.

8d nails at 6" o.c.
Note: For shear transfer, use same nailing as required for sheathing, but complying with Installation Note D, page 15.

Minimum 1 3/4" joist bearing at wall

Toe-nail rim joist to top flange of joist with 10d nail.

F4 SQUASH BLOCKS & SINGLE RIM
Vertical load transfer = 2000 plf max. along load bearing wall

2 3/32" 48/24 APA Rated® sheathing where allowed by local code or use F5

Squash Blocks (2x4 minimum)

8d nails at 6" o.c., toe-nail to plate, typical
Note: For shear transfer, see APA EWS Y250.

8d nail top and bottom flange

8d nail into top flange

8d nail into bottom flange or plate

1/16"

See detail F7 for additional braced wall blocking requirements.

Check local building code for appropriate detail in areas of high lateral load.

F5 F6 FIBERSTRONG® RIM CLOSURE AND DECK ATTACHMENT
Vertical load transfer of rim board = 4850 plf

Do not butt ends at joist location.

One 2x4 min. with 1/8" gap at top, fasten with 8d box nails from each web into 2x_

Blocking where required by local codes for lateral load transfer and/or optional blocking for diaphragm nailing

Starter joist

FiberStrong rim board

8d nails top and bottom flange

8d nails at 6" o.c. toe-nail to plate, typical
Note: For shear transfer, use same nailing as required for sheathing, but complying with Installation Note D, page 15.

(3) 8d nails at corners

FiberStrong rim board

1 1/2"

1 1/2"

Metal flashing-under weather barrier at top, over weather barrier at bottom

1/2" sheathing with weather barrier

2x PT ledger attached with 1/2" diameter through-bolts with washers and nuts or 1/2" lag screws with tip extending a minimum of 1/2" beyond rim board. (See note 1, page 15.) Capacity is 350 pounds per fastener. Bolt/lag screw spacing to be determined by design vertical and lateral load. Lower fastener may alternately be located in wall plate. Use high quality caulk to fill holes and seal flashing.

CAUTION: The lag screw should be inserted in a lead hole by turning with a wrench, not by driving with hammer. Over-torquing can significantly reduce the lateral resistance of the screw and therefore should be avoided.

Siding

Weather Barrier

Sheathing

FiberStrong rim board

Extend flashing below 2x_ ledger and over siding.

Check local building code for appropriate detail in areas of high lateral load.

Floor Details (continued)

F7 BLOCKING PANELS USED FOR BRACED WALL

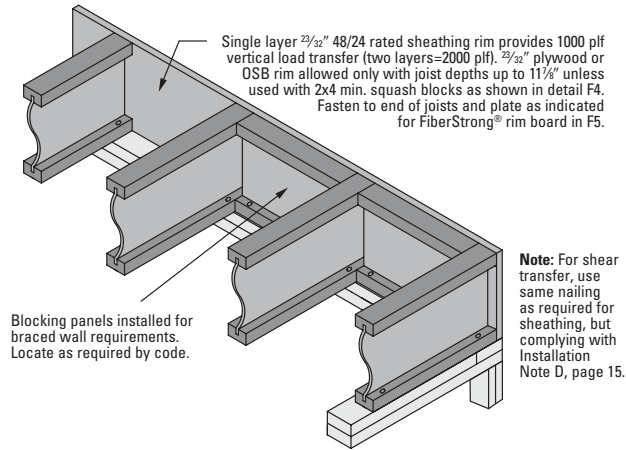

Check local building code for appropriate detail in areas of high lateral load.

F8 BEVEL CUT JOIST

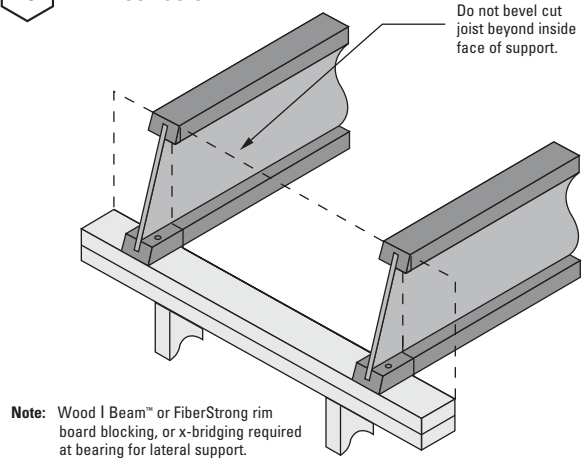

Check local building code for appropriate detail in areas of high lateral load.

F9 BLOCKING PANEL, INTERIOR
Vertical load transfer = 2000 plf max. along load bearing wall.

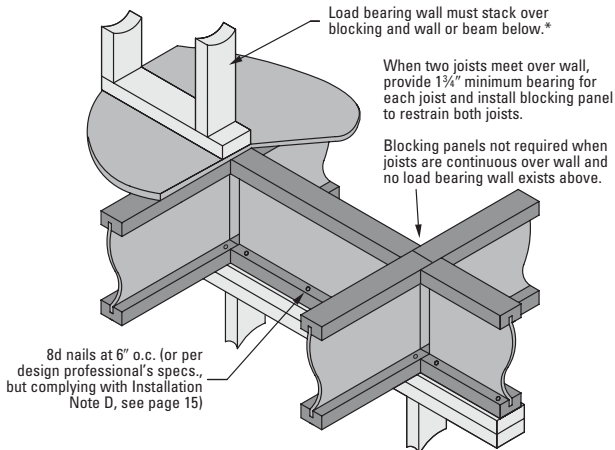

*Non-stacking load bearing walls require additional consideration.

F10 SQUASH BLOCKS AT INTERIOR BEARING
Vertical load transfer = 2000 plf max along load bearing wall.

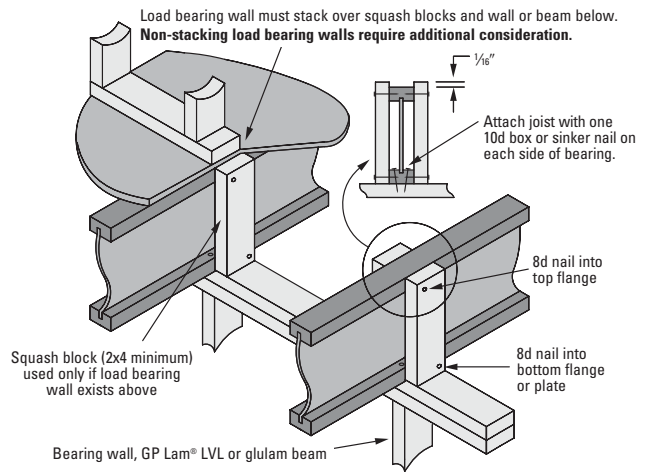

Check local building code for appropriate detail in areas of high lateral load.

F11 DOUBLE JOIST CONSTRUCTION WITH FILLER

Joist Series	Joist Depth	Regular Filler Blocking Use in detail F12	Full-Depth Filler Blocking Use in details C4, F13, F14 & R7
GPI 20	9 1/2"	2x6	2x6
	11 7/8"	2x6	2x8
	14"	2x8	2x10
GPI 40	9 1/2"	2x6 + 3/8" OSB/Plywood	2x6 + 3/8" OSB/Plywood
	11 7/8"	2x6 + 3/8" OSB/Plywood	2x8 + 3/8" OSB/Plywood
	14"	2x8 + 3/8" OSB/Plywood	2x10 + 3/8" OSB/Plywood
GPI 65 WI 40 WI 60	9 1/2"	2x6 + 5/8" OSB/Plywood	2x6 + 5/8" OSB/Plywood
	11 7/8"	2x6 + 5/8" OSB/Plywood	2x8 + 5/8" OSB/Plywood
	14"	2x8 + 5/8" OSB/Plywood	2x10 + 5/8" OSB/Plywood
GPI 90 WI 80	16"	2x8 + 5/8" OSB/Plywood	2x12 + 5/8" OSB/Plywood
	11 7/8"	(2) 2x8	(2) 2x8
	14"	(2) 2x8	(2) 2x10
	16"	(2) 2x8	(2) 2x12

Note: Filler blocks and fastening between joists can be omitted when double joists are loaded evenly from above to the tops of both joists, such as when a parallel bearing wall is directly centered over the double joist.

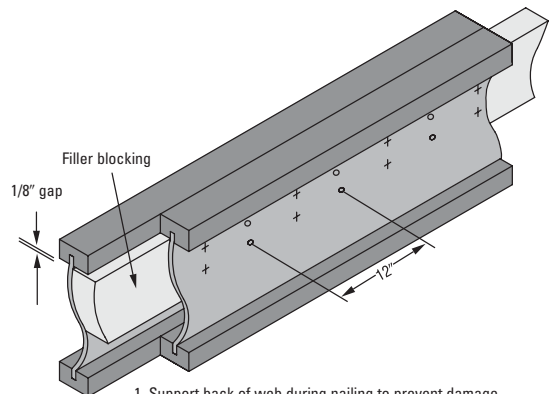

- Support back of web during nailing to prevent damage to web-flange connection.
- Leave 1/8" gap between top of filler blocking and bottom of top flange.
- Block solid between joists. For all applications except cantilever reinforcement, filler need not be one continuous length, but must extend the entire length of span. For double I-joist cantilever reinforcement C4, filler must be one continuous piece extending the full length of the reinforcement.
- Place joists together and nail from each side with 2 rows of 10d (16d for WI 80 and GPI 90) nails at 12" o.c., clinched when possible. Stagger rows from opposite sides by 6".

Floor Details (continued)

F12 FLOOR OPENING, TOP MOUNT HANGERS

Backer Blocks*

Joist Series	Joist Depth	Material	Depth
GPI 20	9½", 11⅞"	2⅜"	5½"
	14"	2⅜"	7¼"
GPI 40	9½", 11⅞"	⅞"	5½"
	14"	⅞"	7¼"
GPI 65, WI 40, WI 60	9½", 11⅞"	½" + ½"	5½"
	14", 16"	½" + ½"	7¼"
GPI 90, WI 80	11⅞", 14", 16"	2x8	7¼"

*Block must be long enough to permit required nailing without splitting.

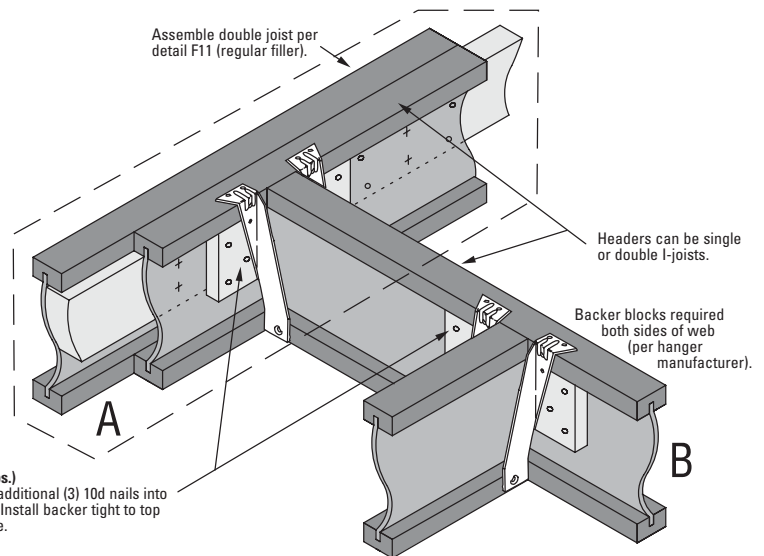

Backer Block (use if hanger load exceeds 250 lbs.)
Before installing backer to double joist, drive an additional (3) 10d nails into web where backer will fit. Clinch when possible. Install backer tight to top flange. Use (10) 10d nails, clinched when possible.

F13 FLOOR OPENING, FACE MOUNT HANGERS

Backer Block

Before installing backer to double joist, drive an additional (3) 10d nails into web where backer will fit. Clinch when possible. Install backer tight to top flange. Use (10) 10d nails, clinched when possible.

Backer Blocks*

Joist Series	Joist Depth	Material	Depth
GPI 20	9½", 11⅞", 14"	2⅜"	6¼", 8¾", 10¾"
GPI 40	9½", 11⅞", 14"	⅞"	6¼", 8¾", 10¾"
GPI 65, WI 40, WI 60	9½", 11⅞", 14", 16"	½" + ½"	6¼", 8¾", 10¾", 12¾"
GPI 90, WI 80	11⅞", 14", 16"	1½" net	8¾", 10¾", 12¾"

*Block must be long enough to permit required nailing without splitting.

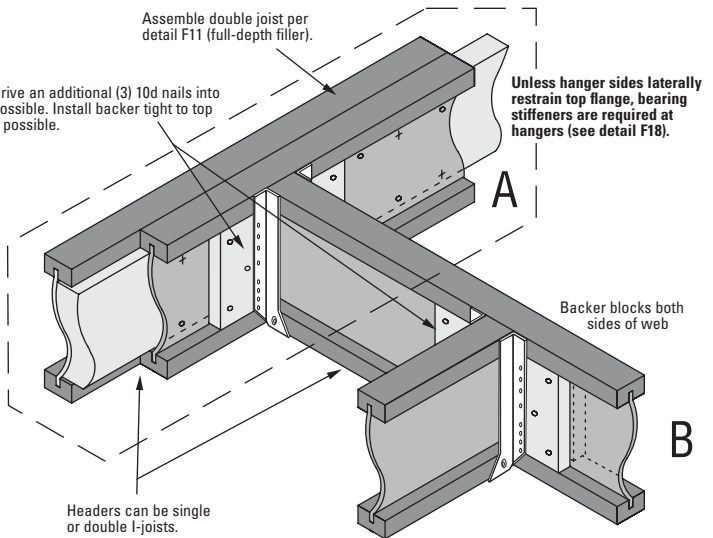

Headers can be single or double I-joists.

F14 STAIR STRINGER TO JOIST CONNECTION

Double Wood I Beam™ joist construction per detail F11 (full depth filler); backer block size and installation per detail F13.

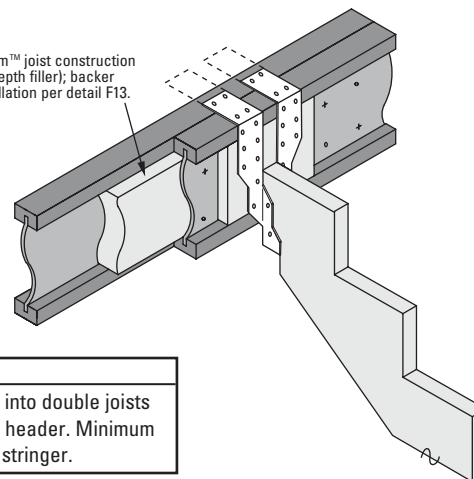

Hangers for 14' (max) Stringer	Nailing Requirement
United Steel Products MSH 218 OR Simpson Strong-Tie® THA 218	Minimum (12) 10d nails into double joists or single or double LVL header. Minimum (4) 10d x 1½" nails into stringer.

For stair stringers longer than 14' or stringer reactions greater than 700 lbs., call Georgia-Pacific.

Floor Details (continued)

F15 JOIST TO BEAM CONNECTION

*Appropriate face mount hangers may be substituted. Properly fastened solid wood blocking of the steel beam also required for face mount hangers on steel beam.

F16 JOIST TO BEAM CONNECTION, STEP DOWN

F17 JOIST TO DROPPED BEAM CONNECTION, STEP DOWN

Bearing stiffeners may be required at hangers. (See detail F18)

See detail F7 for braced wall blocking requirements.

F18 BEARING STIFFENERS

Joist Series	Stiffener Size	Nails
GPI 20	5/8" × 2 5/16"	(3) 10d
GPI 40	1/2" + 1/2" × 2 5/16"	(3) 10d
GPI 65	1/2" + 1/2" × 2 5/16"	(3) 10d
GPI 90	1 1/2" × 2 5/16"	(3) 12d
WI 40	1/2" + 1/2" × 2 5/16"	(3) 10d
WI 60	1/2" + 1/2" × 2 5/16"	(3) 10d
WI 80	1 1/2" × 2 5/16"	(3) 12d

Minimum stiffener width is 2 5/16"

F19 SQUASH BLOCKS AT CONCENTRATED LOADS

Solid block all posts to bearing below with equal number of squash blocks.

F20 WEB STIFFENERS

Stiffeners are required for concentrated loads exceeding 1500 lbs. I-joists **must** be sized to support **all** applied loads. Install stiffeners per detail F18 but tight against top flange and gap at bottom. Verify adequacy of joist to carry concentrated load.

Cantilever Reinforcement Requirements

Joist Depth	Roof Truss Span	ROOF LOADINGS															
		TL = 35 psf LL not to exceed 20 psf Joist spacing				TL = 45 psf LL not to exceed 30 psf Joist spacing				TL = 55 psf LL not to exceed 40 psf Joist spacing				TL = 65 psf LL not to exceed 50 psf Joist spacing			
		12"	16"	19.2"	24"	12"	16"	19.2"	24"	12"	16"	19.2"	24"	12"	16"	19.2"	24"
9 1/2"	26'	0	0	1	2	0	1	2	X	1	2	X	X	2	X	X	X
	28'	0	1	1	2	1	1	2	X	2	X	X	X	2	X	X	X
	30'	0	1	1	2	1	2	X	X	2	X	X	X	X	X	X	X
	32'	0	1	2	X	1	2	X	X	2	X	X	X	X	X	X	X
	34'	0	1	2	X	1	2	X	X	2	X	X	X	X	X	X	X
	36'	1	1	2	X	1	X	X	X	X	X	X	X	X	X	X	X
11 1/2"	26'	0	0	0	0	0	0	0	1	0	1	1	2	1	1	2	X
	28'	0	0	0	1	0	0	1	1	0	1	2	2	1	2	2	X
	30'	0	0	0	1	0	0	1	2	0	1	2	X	1	2	X	X
	32'	0	0	0	1	0	0	1	2	1	1	2	X	1	2	X	X
	34'	0	0	0	1	0	1	1	2	1	2	2	X	1	2	X	X
	36'	0	0	0	1	0	1	1	2	1	2	X	X	1	X	X	X
14"	26'	0	0	0	0	0	0	0	1	0	0	1	1	0	1	1	2
	28'	0	0	0	0	0	0	0	1	0	0	1	1	0	1	1	2
	30'	0	0	0	1	0	0	1	1	0	1	1	2	0	1	1	2
	32'	0	0	0	1	0	0	1	1	0	1	1	2	0	1	2	2
	34'	0	0	0	1	0	0	1	1	0	1	1	2	1	1	2	X
	36'	0	0	0	1	0	0	1	2	0	1	1	2	1	1	2	X
16"	26'	0	0	0	0	0	0	0	1	0	0	1	1	0	1	1	1
	28'	0	0	0	0	0	0	0	1	0	0	1	1	0	1	1	2
	30'	0	0	0	0	0	0	0	1	0	0	1	1	0	1	1	2
	32'	0	0	0	1	0	0	1	1	0	1	1	2	0	1	1	2
	34'	0	0	0	1	0	0	1	1	0	1	1	2	0	1	1	2
	36'	0	0	0	1	0	0	1	1	0	1	1	2	0	1	2	X
16"	38'	0	0	0	1	0	0	1	1	0	1	1	2	1	1	2	X
	40'	0	0	0	1	0	1	1	2	0	1	1	2	1	1	2	X
	42'	0	0	1	1	0	1	1	2	0	1	2	X	1	1	2	X

- 0 - No reinforcement is required. See Detail C1.
- 1 - Single Reinforcement is required. See Detail C2.
- 2 - Double Reinforcement is required. See Detail C3 or C4.
- X - Joist does not work. Select closer spacing or deeper joist.

NOTES:

1. Assumes floor load of 40 psf live load at L/480, 10 psf dead load and maximum joist simple spans.
2. Assumes exterior wall load of 80 plf. Wall load based on 3'-0" maximum width window or door openings. For larger openings, or multiple 3'-0" width openings spaced less than 6'-0" o.c., additional joists beneath the opening's cripple studs may be required.
3. Roof loads use a load duration factor of 115%.
4. This table was designed to cover a broad range of applications. It may be possible to exceed these limitations by analyzing a specific application using FASTBeam® selection software.
5. For stick-built roofs braced to interior supports, with loadings shown above, this table will be conservative. Use FASTBeam software to check for a more economical design.

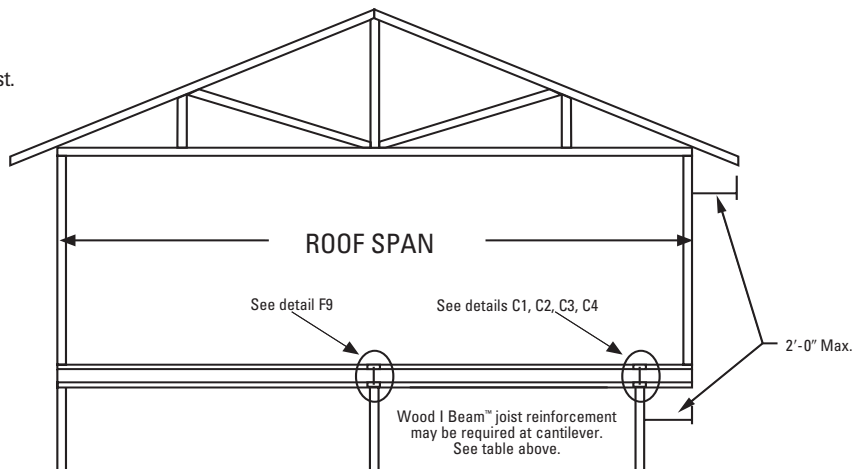

Cantilever Details

C1 CANTILEVER, UNREINFORCED

For allowable wall/roof loads on cantilever, use cantilever table, FASTBeam® software or contact Georgia-Pacific.

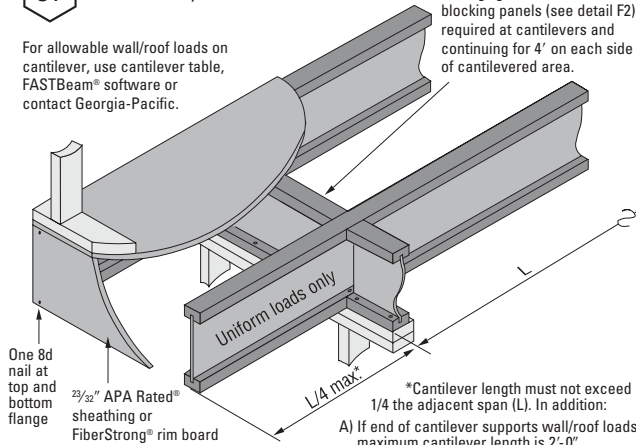

Note: Wood I Beam joists must be protected from the weather.

For other conditions contact Georgia-Pacific.

C2 CANTILEVER, REINFORCED Single Sheathing/Rim Board (Option I)

For allowable wall/roof loads on cantilever, use cantilever table, FASTBeam® software or contact Georgia-Pacific.

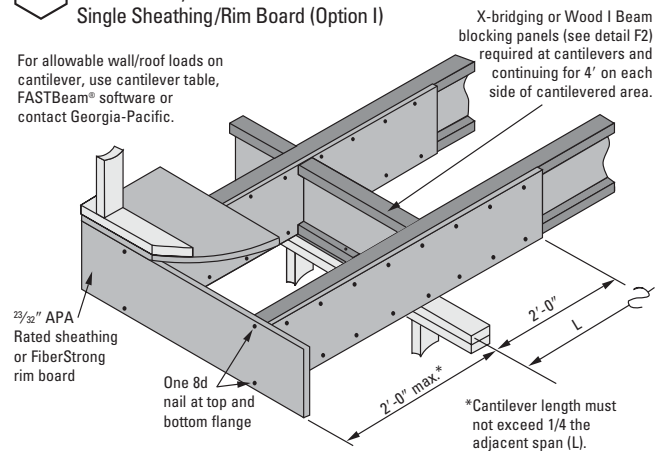

Note: FiberStrong rim board or 48/24 APA Rated sheathing (strength axis horizontal) required one side of joist. Depth must match full depth of joist. Nail to joist flanges with 8d nails at 6" o.c.

C3 CANTILEVER, REINFORCED Double Sheathing/Rim Board (Option II)

For allowable wall/roof loads on cantilever, use cantilever table, FASTBeam® software or contact Georgia-Pacific.

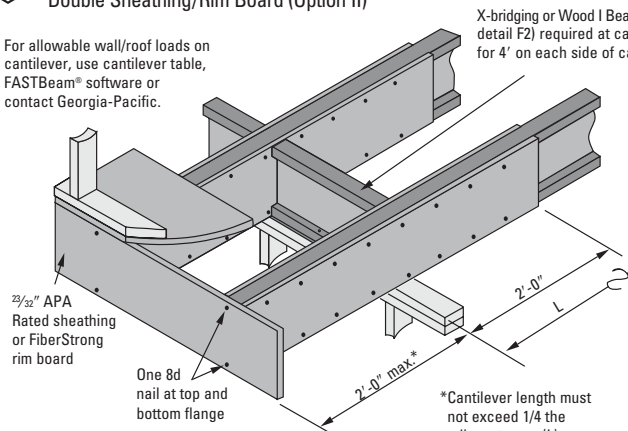

Note: FiberStrong rim board or 48/24 APA Rated sheathing (strength axis horizontal) required both sides of joist. Depth must match full depth of joist.

X-briding or Wood I Beam blocking panels (see detail F2) required at cantilevers and continuing for 4' on each side of cantilevered area.

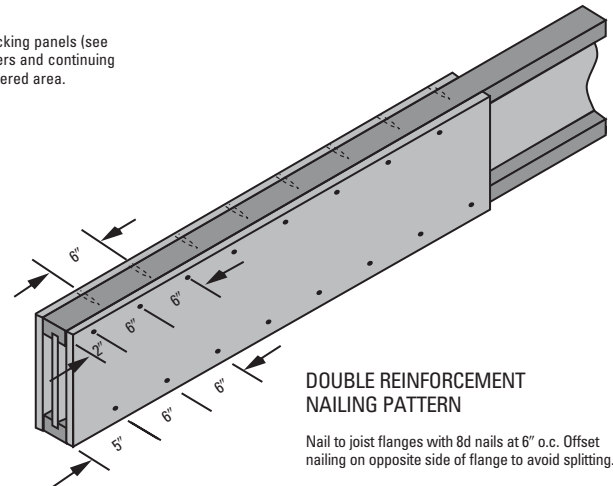

C4 CANTILEVER, REINFORCED Double Joist (Option III)

For allowable wall/roof loads on cantilever, use cantilever table, FASTBeam® software or contact Georgia-Pacific.

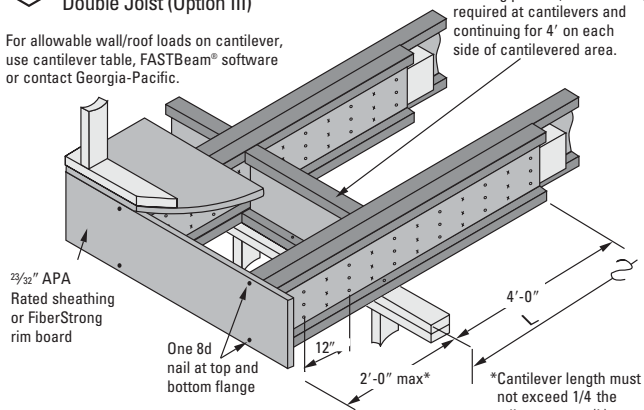

Note: Block together full length with full-depth filler blocking. See detail F11 for filler size, except filler must be one continuous length. Use 2 rows of 10d (16d for WI 80 and GPI 90) nails at 12" o.c. from each side; offset opposite side nailing by 6". Clinch nails when possible.

X-briding or Wood I Beam blocking panels (see detail F2) required at cantilevers and continuing for 4' on each side of cantilevered area.

C5 CANTILEVER, DROPPED

X-briding or Wood I Beam blocking panels (see detail F2) required at cantilevers and continuing for 4' on each side of cantilevered area.

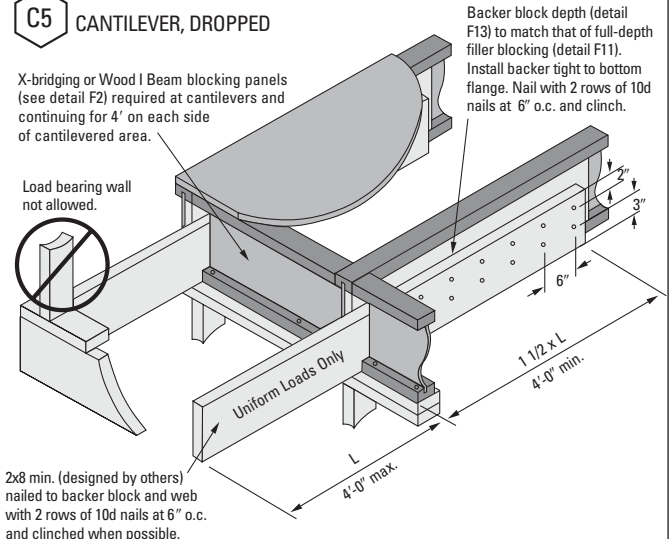

Roof Details

<p>R1 RIDGE-JOIST CONNECTION 12/12 maximum slope</p> <p>Additional uplift connections may be required.</p> <p>*Strap required for members with slope of 3/12 and greater.</p>	<p>R2 UPPER END, BEARING ON WALL 12/12 maximum slope</p> <p>Alternate 2: FiberStrong® rim board or 3/32" 48/24 APA Rated® sheathing as continuous closure. Nail to top and bottom flange with 8d nails. Toe-nail to plate with 8d nails at 6" o.c.</p> <p>*Strap required for members with slope of 3/12 and greater.</p> <p>Blocking panel: Wood I Beam™ (nail through top of flange to plate) or FiberStrong® rim board (toe-nail to plate). Use 8d nails at 6" o.c. Alternate 1 (not shown): x-bridding attached to top flanges and to plate.</p> <p>For Wood I Beam blocking panel shear transfer, use same nailing as required for sheathing, but complying with Installation Note D, page 15. For rim board or continuous closure shear transfer, see APA EWS Y250.</p> <p>Follow detail F1 for nailing to bearing plate. Additional uplift connections may be required.</p>
<p>R3 JOISTS ABOVE RIDGE SUPPORT BEAM 12/12 maximum slope</p> <p>Follow detail F1 for nailing to bearing plate. Additional uplift connections may be required.</p> <p>Double beveled wood plate.</p> <p>GP Lam LVL or glulam support beam</p> <p>Blocking panel: Wood I Beam (nail through top of flange to plate) or FiberStrong® rim board (toe-nail to plate). Use 8d nails at 6" o.c. Alternate 1 (not shown): x-bridding attached to top flanges and to plate.</p> <p>For Wood I Beam blocking panel shear transfer, use same nailing as required for sheathing, but complying with Installation Note D, page 15. For rim board shear transfer, see APA EWS Y250.</p>	<p>R4 BIRDSMOUTH CUT Low end of joist only. 12/12 maximum slope</p> <p>Blocking panel: Wood I Beam (for low-sloped roofs only) (nail through top of flange to plate) or FiberStrong® rim board (toe-nail to plate). Use 8d nails at 6" o.c. Alternate 1 (not shown): x-bridding attached to top flanges and to plate.</p> <p>Follow detail F1 for nailing to bearing plate. Additional uplift connections may be required.</p> <p>For Wood I Beam blocking panel shear transfer, use same nailing as required for sheathing, but complying with Installation Note D, page 15. For rim board shear transfer, see APA EWS Y250.</p> <p>Notch Wood I Beam joist to provide full bearing for bottom flange.</p>
<p>R5 JOISTS ON BEVELED PLATE 12/12 maximum slope</p> <p>Blocking panel: Wood I Beam (nail through top of flange to plate) or FiberStrong® rim board (toe-nail to plate). Use 8d nails at 6" o.c. Alternate 1 (not shown): x-bridding attached to top flanges and to plate.</p> <p>For Wood I Beam blocking panel shear transfer, use same nailing as required for sheathing, but complying with Installation Note D, page 15. For rim board shear transfer, see APA EWS Y250.</p> <p>Follow detail F1 for nailing to bearing plate. Additional uplift connections may be required.</p>	<p>R6 BIRDSMOUTH CUT Low end of joist only 12/12 maximum slope</p> <p>Blocking panel: Wood I Beam (nail through top of flange to plate) or FiberStrong® rim board (toe-nail to plate). Use 8d nails at 6" o.c. Alternate 1 (not shown): x-bridding attached to top flanges and to plate.</p> <p>For Wood I Beam blocking panel shear transfer, use same nailing as required for sheathing, but complying with Installation Note D, page 15. For rim board shear transfer, see APA EWS Y250.</p> <p>Follow detail F1 for nailing to bearing plate. Additional uplift connections may be required.</p>

Roof Details (continued)

R7 ROOF OPENING, FACE MOUNT HANGERS
12/12 maximum slope

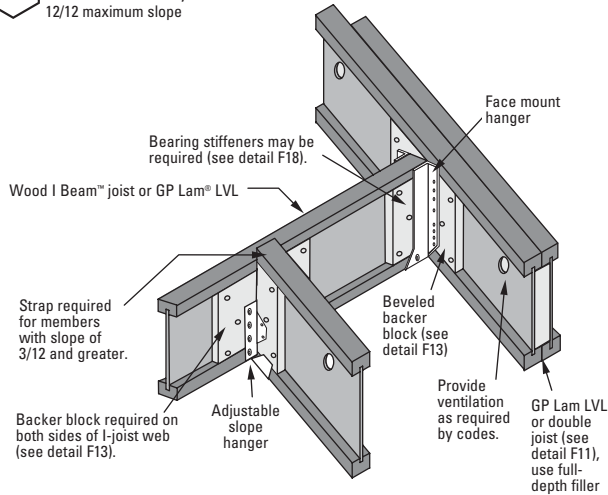

Additional uplift connections may be required.

R8 BEVELED CUT BEARING STIFFENER
12/12 maximum slope

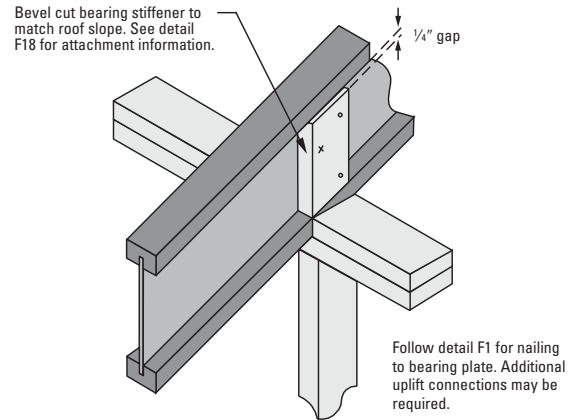

R10 OPTIONAL OVERHANG EXTENSIONS
12/12 maximum slope May be used with detail R4, R5, and R6 (Low end only)

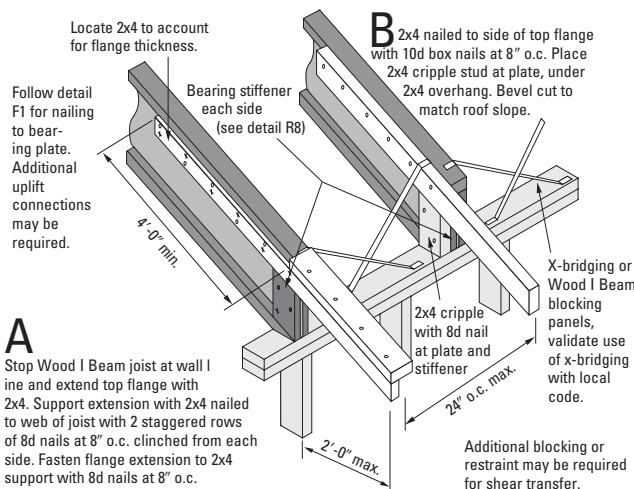

A Stop Wood I Beam joist at wall line and extend top flange with 2x4. Support extension with 2x4 nailed to web of joist with 2 staggered rows of 8d nails at 8" o.c. clinched from each side. Fasten flange extension to 2x4 support with 8d nails at 8" o.c.

R11 OVERHANG PARALLEL TO JOIST
12/12 maximum slope

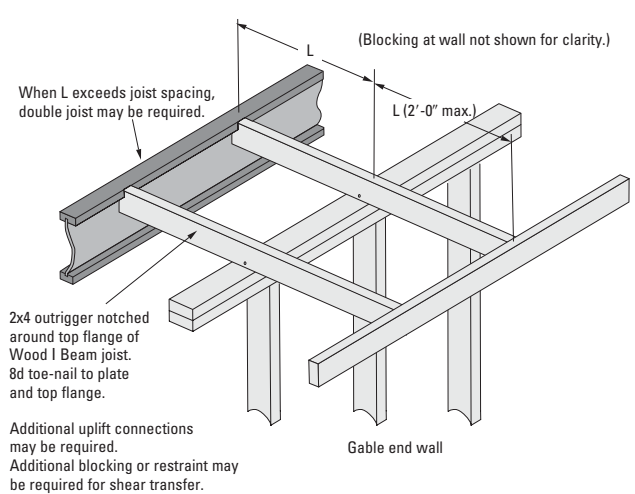

RB ROOF BLOCKING WITH PERMITTED VENTILATION

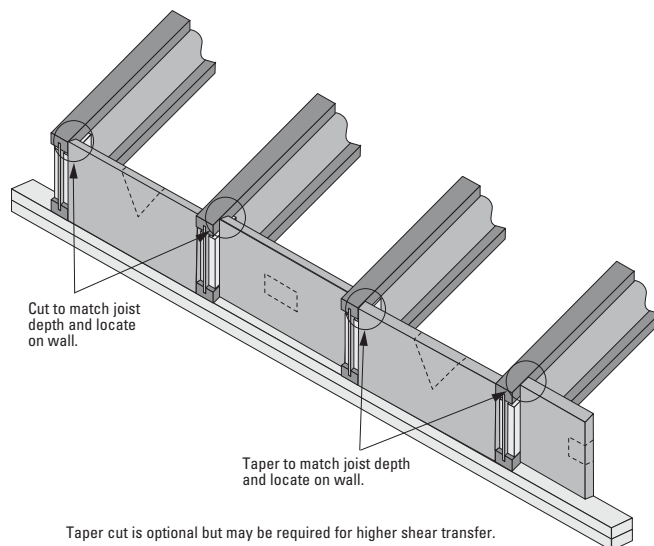
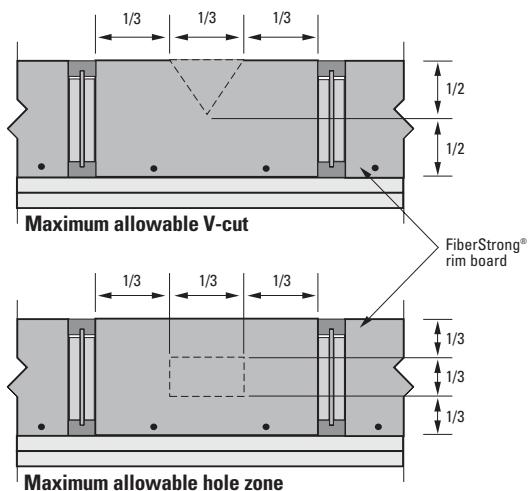

Hole Location for GPI 20, 40 and 65 (Simple or Multiple Span)

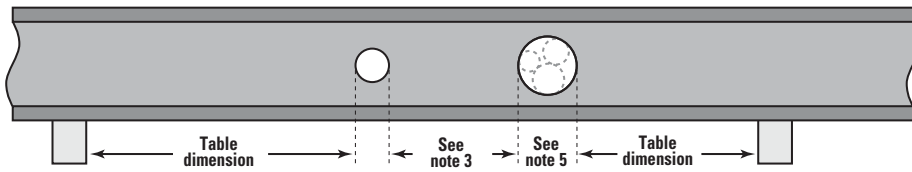

Do not drill or cut flanges.



Table dimension is minimum distance from inside face of support to nearest edge of hole.

Joist Depth	Joist Clear Span	Round Hole Diameter														
		2"	3"	4"	5"	6"	6 1/2"	7"	8"	8 1/2"	9"	10"	11"	12"	13"	
9 1/2"	10'	0'-6"	0'-6"	0'-9"	1'-9"	2'-9"	3'-6"	Not Permitted						Not Permitted		
	12'	0'-6"	1'-0"	2'-0"	3'-0"	4'-3"	4'-9"	Not Permitted						Not Permitted		
	14'	1'-0"	2'-0"	3'-0"	4'-3"	5'-6"	6'-0"	Not Permitted						Not Permitted		
	16'	0'-6"	0'-6"	1'-9"	3'-6"	5'-0"	6'-0"	Not Permitted						Not Permitted		
	18'	0'-6"	0'-6"	0'-9"	2'-3"	4'-6"	5'-6"	Not Permitted						Not Permitted		
11 1/2"	10'	0'-6"	0'-6"	0'-9"	1'-0"	1'-0"	1'-0"	1'-3"	2'-3"	3'-3"	Not Permitted				Not Permitted	
	12'	0'-6"	0'-6"	0'-9"	1'-0"	1'-6"	2'-0"	2'-6"	3'-9"	4'-9"	Not Permitted				Not Permitted	
	14'	0'-6"	0'-6"	0'-9"	1'-9"	2'-9"	3'-6"	4'-0"	5'-0"	6'-3"	Not Permitted				Not Permitted	
	16'	0'-6"	1'-0"	2'-0"	3'-0"	4'-0"	4'-9"	5'-3"	6'-6"	7'-6"	Not Permitted				Not Permitted	
	18'	0'-6"	0'-6"	1'-3"	2'-6"	4'-0"	4'-9"	5'-6"	7'-0"	8'-6"	Not Permitted				Not Permitted	
	20'	0'-6"	1'-3"	2'-6"	4'-0"	5'-3"	6'-0"	6'-9"	8'-6"	Not Permitted				Not Permitted		
	22'	0'-6"	0'-6"	1'-3"	3'-0"	4'-6"	5'-6"	6'-3"	8'-3"	10'-0"	Not Permitted				Not Permitted	
24'	0'-6"	0'-6"	0'-9"	1'-0"	2'-6"	3'-9"	4'-9"	7'-3"	9'-3"	Not Permitted				Not Permitted		
14"	12'	0'-6"	0'-6"	0'-9"	1'-0"	1'-0"	1'-0"	1'-3"	2'-3"	2'-3"	3'-6"	4'-6"	Not Permitted			
	14'	0'-6"	0'-6"	0'-9"	1'-0"	1'-0"	1'-0"	1'-6"	2'-6"	3'-6"	3'-9"	4'-9"	6'-0"			
	16'	0'-6"	0'-6"	0'-9"	1'-0"	1'-9"	2'-3"	2'-9"	4'-0"	5'-0"	5'-0"	6'-3"	7'-6"			
	18'	0'-6"	0'-6"	0'-9"	1'-0"	1'-6"	2'-0"	2'-9"	4'-0"	5'-3"	5'-3"	6'-9"	8'-6"			
	20'	0'-6"	0'-6"	0'-9"	1'-3"	2'-6"	3'-3"	3'-9"	5'-3"	6'-6"	6'-6"	8'-0"	10'-3"			
	22'	0'-6"	0'-6"	0'-9"	1'-0"	1'-3"	2'-0"	2'-9"	4'-6"	6'-0"	6'-3"	8'-0"	10'-3"			
	24'	0'-6"	0'-6"	0'-9"	1'-0"	2'-6"	3'-3"	4'-3"	5'-9"	7'-6"	7'-9"	9'-9"	Example below			
	26'	0'-6"	0'-6"	0'-9"	1'-0"	1'-3"	2'-3"	3'-3"	5'-0"	7'-0"	7'-3"	9'-6"	12'-0"			
28'	0'-6"	0'-6"	0'-9"	1'-0"	1'-0"	1'-9"	3'-0"	5'-0"	7'-0"	7'-3"	9'-9"	12'-3"				
16"	14'	0'-6"	0'-6"	0'-9"	1'-0"	1'-0"	1'-0"	1'-0"	1'-0"	1'-0"	1'-3"	2'-3"	3'-6"	4'-6"	6'-0"	
	16'	0'-6"	0'-6"	0'-9"	1'-0"	1'-0"	1'-0"	1'-0"	1'-6"	2'-6"	2'-6"	4'-9"	6'-0"	7'-3"		
	18'	0'-6"	0'-6"	0'-9"	1'-0"	1'-0"	1'-0"	1'-0"	1'-0"	2'-3"	2'-3"	3'-9"	5'-0"	6'-6"	8'-3"	
	20'	0'-6"	0'-6"	0'-9"	1'-0"	1'-0"	1'-0"	1'-0"	2'-3"	3'-6"	3'-9"	5'-0"	6'-6"	8'-3"		
	22'	0'-6"	0'-6"	0'-9"	1'-0"	1'-0"	1'-0"	1'-0"	1'-0"	2'-6"	2'-9"	4'-3"	6'-0"	8'-0"	10'-0"	
	24'	0'-6"	0'-6"	0'-9"	1'-0"	1'-0"	1'-0"	1'-0"	2'-3"	3'-9"	4'-0"	5'-9"	7'-6"	9'-6"		
	26'	0'-6"	0'-6"	0'-9"	1'-0"	1'-0"	1'-0"	1'-0"	1'-0"	2'-9"	3'-0"	5'-0"	7'-0"	9'-3"	11'-9"	
	28'	0'-6"	0'-6"	0'-9"	1'-0"	1'-0"	1'-0"	1'-0"	2'-3"	4'-0"	4'-3"	6'-3"	8'-6"	10'-9"		
	30'	0'-6"	0'-6"	0'-9"	1'-0"	1'-0"	1'-0"	1'-0"	2'-0"	3'-9"	4'-0"	6'-3"	8'-6"	11'-0"	13'-9"	

NOTES:

- Hole locations are based on worst case of simple and multiple span conditions with uniform floor loads of 40 PSF live load and 10 or 20 PSF dead load, and spans from page 6.
- Small holes not greater than 1.5" in diameter can be placed anywhere in the web, but each hole must be spaced a minimum horizontal clear distance of 2 times its diameter (but not less than 1") from any adjacent hole. No more than two small holes can be placed next to each other and/or adjacent to larger holes following the guidelines in this note. More than one group of small holes is permitted on a joist, but adjacent groups must be spaced a minimum horizontal clear distance of 12".
- For holes greater than 1.5" diameter, minimum clear distance between
 - two round holes is 2 times the diameter of the larger hole
 - a round hole and a rectangular hole is the larger of 2 times the hole diameter or twice the rectangular hole width
- For rectangular holes, the longest side may not exceed 75% of a round hole diameter permitted at that location; i.e., if an 8 inch round hole is permitted, the longest side of a rectangular hole centered at that location is 8" x 0.75 = 6".

- A group of round holes at approximately the same location shall be permitted if they meet the requirements for a single round hole circumscribed around them.
- For joists with more than one span, use the longest span to determine hole location in either span. For large differences in adjacent span lengths, use FASTBeam® software.
- All holes shown on this table may be located vertically anywhere within the web; a clear distance of at least 1/8" must be maintained from the hole edge to the inner surface of the closest flange.
- For other conditions use FASTBeam software. Analysis using FASTBeam software could permit larger holes, or holes closer to the supports than shown in this table.

EXAMPLE:

Determine the allowable location of a 9" round hole in a 14" deep GPI Series joist which spans 20'.
 Enter the table in the left column and find 14" joist depth, move to the right and find 20' in the joist span column and move across the table to intersect the 9" round hole column. The nearest allowable location to either bearing is 6'-9".

Hole Location for GPI 90 and WI Series (Simple or Multiple Span)

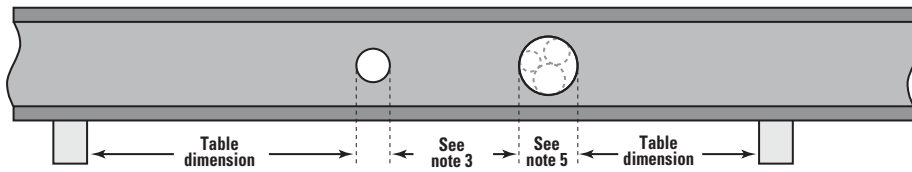

Do not drill or cut flanges.



Table dimension is minimum distance from inside face of support to nearest edge of hole.

Joist Depth	Joist Clear Span	Round Hole Diameter														
		2"	3"	4"	5"	6 1/4"	7"	8"	8 1/2"	9"	10"	10 1/4"	11"	12"	12 1/4"	
9 1/2"	10'	0'-6"	0'-6"	0'-9"	1'-9"	3'-3"	Not Permitted									
	12'	0'-6"	1'-3"	2'-3"	3'-3"	4'-6"	Not Permitted									
	14'	0'-6"	1'-0"	2'-3"	3'-6"	5'-6"	Not Permitted									
	16'	0'-6"	0'-6"	2'-0"	3'-6"	5'-9"	Not Permitted									
11 1/8"	12'	0'-6"	0'-6"	0'-9"	1'-0"	1'-9"	2'-6"	3'-9"	4'-6"	Not Permitted					Not Permitted	
	14'	0'-6"	0'-6"	0'-9"	1'-9"	3'-3"	4'-0"	5'-3"	6'-0"	Not Permitted					Not Permitted	
	16'	0'-6"	1'-3"	2'-3"	3'-3"	4'-6"	5'-6"	6'-6"	7'-6"	Not Permitted					Not Permitted	
	18'	1'-6"	2'-6"	3'-6"	4'-6"	6'-0"	6'-9"	8'-0"	Not Permitted					Not Permitted		
	20'	0'-9"	2'-0"	3'-3"	4'-6"	6'-3"	7'-3"	8'-9"	Not Permitted					Not Permitted		
	22'	1'-6"	2'-9"	4'-0"	5'-6"	7'-3"	8'-3"	9'-9"	Not Permitted					Not Permitted		
14"	12'	0'-6"	0'-6"	0'-9"	1'-0"	1'-0"	1'-0"	1'-3"	1'-9"	2'-3"	3'-6"	4'-3"	Not Permitted			
	14'	0'-6"	0'-6"	0'-9"	1'-0"	1'-0"	1'-6"	2'-6"	3'-3"	3'-9"	4'-9"	5'-9"	Not Permitted			
	16'	0'-6"	0'-6"	0'-9"	1'-0"	2'-0"	2'-9"	4'-0"	4'-6"	5'-0"	6'-3"	7'-3"	Not Permitted			
	18'	0'-6"	0'-6"	1'-0"	2'-0"	3'-3"	4'-3"	5'-3"	6'-0"	6'-6"	7'-9"	8'-6"	Not Permitted			
	20'	0'-6"	0'-6"	0'-9"	1'-6"	3'-0"	4'-0"	5'-3"	6'-3"	6'-9"	8'-6"	10'-0"	Not Permitted			
	22'	0'-6"	0'-6"	1'-6"	2'-9"	4'-3"	5'-6"	6'-9"	7'-9"	8'-3"	10'-0"	10'-9"	Not Permitted			
	24'	0'-6"	1'-0"	2'-3"	3'-6"	5'-3"	6'-3"	7'-9"	8'-9"	9'-3"	10'-9"	11'-3"	Not Permitted			
	26'	0'-6"	0'-6"	1'-0"	2'-6"	4'-6"	5'-9"	7'-6"	8'-6"	9'-3"	11'-3"	Not Permitted				
16"	14'	0'-6"	0'-6"	0'-9"	1'-0"	1'-0"	1'-0"	1'-0"	1'-0"	1'-3"	2'-6"	3'-3"	3'-6"	4'-9"	5'-6"	
	16'	0'-6"	0'-6"	0'-9"	1'-0"	1'-0"	1'-0"	1'-6"	2'-3"	2'-9"	3'-9"	4'-6"	5'-0"	6'-3"	7'-0"	
	18'	0'-6"	0'-6"	0'-9"	1'-0"	1'-0"	2'-0"	3'-0"	3'-6"	4'-0"	5'-3"	6'-0"	6'-3"	7'-6"	Not Permitted	
	20'	0'-6"	0'-6"	0'-9"	1'-0"	1'-0"	1'-6"	2'-9"	3'-6"	4'-0"	5'-3"	6'-3"	6'-9"	8'-3"	Not Permitted	
	22'	0'-6"	0'-6"	0'-9"	1'-0"	1'-9"	2'-9"	4'-0"	4'-9"	5'-3"	6'-9"	7'-9"	8'-3"	9'-9"	Not Permitted	
	24'	0'-6"	0'-6"	0'-9"	1'-0"	2'-6"	3'-6"	4'-9"	5'-6"	6'-3"	7'-6"	8'-9"	9'-0"	10'-9"	Not Permitted	
	26'	0'-6"	0'-6"	0'-9"	1'-0"	2'-0"	3'-0"	4'-6"	5'-6"	6'-3"	8'-0"	9'-3"	9'-9"	11'-9"	Not Permitted	
	28'	0'-6"	0'-6"	0'-9"	1'-0"	2'-6"	3'-6"	5'-3"	6'-3"	7'-0"	8'-9"	10'-3"	10'-9"	12'-9"	Not Permitted	
	30'	0'-6"	0'-6"	0'-9"	1'-9"	3'-9"	5'-0"	6'-6"	7'-6"	8'-3"	10'-0"	11'-6"	11'-9"	13'-9"	Not Permitted	
	32'	0'-6"	0'-6"	0'-9"	1'-0"	2'-3"	3'-6"	5'-6"	6'-9"	7'-6"	9'-6"	11'-0"	11'-6"	13'-9"	Not Permitted	

NOTES:

- Hole locations are based on worst case of simple and multiple span conditions with uniform floor loads of 40 PSF live load and 10 or 20 PSF dead load, and spans from page 6.
- Small holes not greater than 1.5" in diameter can be placed anywhere in the web, but each hole must be spaced a minimum horizontal clear distance of 2 times its diameter (but not less than 1") from any adjacent hole. No more than two small holes can be placed next to each other and/or adjacent to larger holes following the guidelines in this note. More than one group of small holes is permitted on a joist, but adjacent groups must be spaced a minimum horizontal clear distance of 12".
- For holes greater than 1.5" diameter, minimum clear distance between
 - two round holes is 2 times the diameter of the larger hole
 - a round hole and a rectangular hole is the larger of 2 times the hole diameter or twice the rectangular hole width
- For rectangular holes, the longest side may not exceed 75% of a round hole diameter permitted at that location; i.e., if an 8 inch round hole is permitted, the longest side of a rectangular hole centered at that location is 8" x 0.75 = 6".

- A group of round holes at approximately the same location shall be permitted if they meet the requirements for a single round hole circumscribed around them.
- For joists with more than one span, use the longest span to determine hole location in either span. For large differences in adjacent span lengths, use FASTBeam® software.
- All holes shown on this table may be located vertically anywhere within the web; a clear distance of at least 1/8" must be maintained from the hole edge to the inner surface of the closest flange.
- For other conditions use FASTBeam software. Analysis using FASTBeam software could permit larger holes, or holes closer to the supports than shown in this table.

EXAMPLE:

Determine the allowable location of a 9" round hole in a 14" deep WI Series joist which spans 20'.
 Enter the table in the left column and find 14" joist depth, move to the right and find 20' in the joist span column and move across the table to intersect the 9" round hole column. The nearest allowable location to either bearing is 6'-9".

Framing Connectors for Wood I Beam™ Joists

USP Structural Connectors™																					
Joist Series	Joist Depth	Top Mount	Cpcy ^{1,2} Lbs-100%	Nailing ⁷		Face Mount	Cpcy ^{1,3} Lbs-100%	Nailing ⁷		Double Face Mount	Cpcy ^{1,3} Lbs-100%	Nailing ⁷		Field Sloped & Skewed	Cpcy ^{1,3,5} Lbs-115%	Nailing ⁷		Variable Pitch	Cpcy ^{1,4} Lbs-115%	Nailing ⁷	
				H	J			H	J			H	J			H	J			P	J
GPI 20	9 1/2"	THO17950	1134	10d x 1 1/2"	10d x 1 1/2"	THF17925	1370	10d	10d x 1 1/2"	THF35925	1370	10d	10d x 1 1/2"	LSSH179	1310	10d	10d x 1 1/2"	TMP175	1150	10d	10d x 1 1/2"
	11 7/8"	THO17118	1175	10d x 1 1/2"	10d x 1 1/2"	THF17112	1825	10d	10d x 1 1/2"	THF35112	1825	10d	10d x 1 1/2"	LSSH179	1310	10d	10d x 1 1/2"	TMP175	1150	10d	10d x 1 1/2"
	14"	THO17140	1584	10d x 1 1/2"	10d x 1 1/2"	THF17140	2280	10d	10d x 1 1/2"	THF35140	2320	10d	10d x 1 1/2"	LSSH179	1310	10d	10d x 1 1/2"	TMP175	1150	10d	10d x 1 1/2"
GPI 40	9 1/2"	THO23950	1056	10d x 1 1/2"	10d x 1 1/2"	THF23925	1370	10d	10d x 1 1/2"	THF23925-2 ^a	1625	10d	10d x 1 1/2"	LSSH23	1310	10d	10d x 1 1/2"	TMP23	1970	10d	10d x 1 1/2"
	11 7/8"	THO23118	1193	10d x 1 1/2"	10d x 1 1/2"	THF23118	1595	10d	10d x 1 1/2"	THF23118-2 ^a	1855	10d	10d x 1 1/2"	LSSH23	1310	10d	10d x 1 1/2"	TMP23	1970	10d	10d x 1 1/2"
	14"	THO23140	1765	10d x 1 1/2"	10d x 1 1/2"	THF23140	2090	10d	10d x 1 1/2"	THF23140-2 ^a	2500	10d	10d x 1 1/2"	LSSH23	1310	10d	10d x 1 1/2"	TMP23	1970	10d	10d x 1 1/2"
WI 40, 60 & GPI 65	9 1/2"	THO25950	1056	10d x 1 1/2"	10d x 1 1/2"	THF25925	1370	10d	10d x 1 1/2"	THF25925-2 ^a	1390	10d	10d	LSSH25	1825	16d	10d x 1 1/2"	TMP25	1970	10d	10d x 1 1/2"
	11 7/8"	THO25118	1193	10d x 1 1/2"	10d x 1 1/2"	THF25112	1595	10d	10d x 1 1/2"	THF25112-2 ^a	1855	10d	10d	LSSH25	1825	16d	10d x 1 1/2"	TMP25	1970	10d	10d x 1 1/2"
	14"	THO25140	1765	10d x 1 1/2"	10d x 1 1/2"	THF25140	2090	10d	10d x 1 1/2"	THF25140-2 ^a	2500	10d	10d	LSSH25	1825	16d	10d x 1 1/2"	TMP25	1970	10d	10d x 1 1/2"
WI 80 & GPI 90	11 7/8"	THO35118	2050	10d x 1 1/2"	10d x 1 1/2"	THF35112	1570	10d	10d x 1 1/2"	HD7120 ^a	1935	16d	10d	LSSH35	1915	16d	10d x 1 1/2"	TMP4	1970	10d	10d x 1 1/2"
	14"	THO35140	2100	10d x 1 1/2"	10d x 1 1/2"	THF35140	2000	10d	10d x 1 1/2"	HD7140 ^a	2420	16d	10d	LSSH35	1915	16d	10d x 1 1/2"	TMP4	1970	10d	10d x 1 1/2"
	16"	THO35160	2100	10d x 1 1/2"	10d x 1 1/2"	THF35157	2200	10d	10d x 1 1/2"	HD7160 ^a	2905	16d	10d	LSSH35	1915	16d	10d x 1 1/2"	TMP4	1970	10d	10d x 1 1/2"

Simpson Strong-Tie® Connectors																					
Joist Series	Joist Depth	Top Mount	Cpcy ^{1,2} Lbs-100%	Nailing ⁷		Face Mount	Cpcy ^{1,3} Lbs-100%	Nailing ⁷		Double Face Mount	Cpcy ^{1,3} Lbs-100%	Nailing ⁷		Field Sloped & Skewed	Cpcy ^{1,3,5} Lbs-115%	Nailing ⁷		Variable Pitch	Cpcy ^{1,4} Lbs-115%	Nailing ⁷	
				H	J			H	J			H	J			H	J			P	J
GPI 20	9 1/2"	ITT9.5	1050	10d x 1 1/2"	10d x 1 1/2"	IUT9	890	10d	10d x 1 1/2"	MIU3.56/9	1907	10d	10d x 1 1/2"	LSSUI25	1145	10d	10d x 1 1/2"	VPA25	870	10d	10d x 1 1/2"
	11 7/8"	ITT11.88	1050	10d x 1 1/2"	10d x 1 1/2"	IUT11	1110	10d	10d x 1 1/2"	MIU3.56/11	2386	10d	10d x 1 1/2"	LSSUI25	1145	10d	10d x 1 1/2"	VPA25	870	10d	10d x 1 1/2"
	14"	ITT14	1050	10d x 1 1/2"	10d x 1 1/2"	IUT14	1555	10d	10d x 1 1/2"	MIU3.56/14	2625	10d	10d x 1 1/2"	LSSUI25	1145	10d	10d x 1 1/2"	VPA25	870	10d	10d x 1 1/2"
GPI 40	9 1/2"	ITT359.5	1050	10d x 1 1/2"	10d x 1 1/2"	IUT3510	890	10d	10d x 1 1/2"	MIU4.75/9	1907	10d	10d x 1 1/2"	LSSUI35	1145	10d	10d x 1 1/2"	VPA35	1020	10d	10d x 1 1/2"
	11 7/8"	ITT3511.88	1050	10d x 1 1/2"	10d x 1 1/2"	IUT3512	1110	10d	10d x 1 1/2"	MIU4.75/11	2386	10d	10d x 1 1/2"	LSSUI35	1145	10d	10d x 1 1/2"	VPA35	1020	10d	10d x 1 1/2"
	14"	ITT3514	1050	10d x 1 1/2"	10d x 1 1/2"	IUT3514	1555	10d	10d x 1 1/2"	MIU4.75/14	2625	10d	10d x 1 1/2"	LSSUI35	1145	10d	10d x 1 1/2"	VPA35	1020	10d	10d x 1 1/2"
WI 40, 60 & GPI 65	9 1/2"	ITT39.5	1050	10d x 1 1/2"	10d x 1 1/2"	IUT310	890	10d	10d x 1 1/2"	MIU5.12/9	1907	10d	10d x 1 1/2"	LSSUH310	1344	10d	10d x 1 1/2"	VPA3	1020	10d	10d x 1 1/2"
	11 7/8"	ITT311.88	1050	10d x 1 1/2"	10d x 1 1/2"	IUT312	1110	10d	10d x 1 1/2"	MIU5.12/11	2386	10d	10d x 1 1/2"	LSSUH310	1344	10d	10d x 1 1/2"	VPA3	1020	10d	10d x 1 1/2"
	14"	ITT314	1050	10d x 1 1/2"	10d x 1 1/2"	IUT314	1555	10d	10d x 1 1/2"	MIU5.12/14	2625	10d	10d x 1 1/2"	LSSUH310	1344	10d	10d x 1 1/2"	VPA3	1020	10d	10d x 1 1/2"
WI 80 & GPI 90	11 7/8"	MIT316	1230	10d x 1 1/2"	10d x 1 1/2"	IUT316	1775	10d	10d x 1 1/2"	MIU5.12/16	2864	10d	10d x 1 1/2"	LSSUH310	1344	10d	10d x 1 1/2"	VPA3	1020	10d	10d x 1 1/2"
	14"	ITT411.88	1050	10d x 1 1/2"	10d x 1 1/2"	IUT412	960	10d	10d x 1 1/2"	HU412-2 ^a	1855	16d	16d	LSSU410	1625	16d	10d x 1 1/2"	VPA4	1020	10d	10d x 1 1/2"
	16"	MIT416	1230	10d x 1 1/2"	10d x 1 1/2"	IUT416	1535	10d	10d x 1 1/2"	HU414-2 ^a	2320	16d	16d	LSSU410	1625	16d	10d x 1 1/2"	VPA4	1020	10d	10d x 1 1/2"

NOTES:

- Capacity is for the stated duration of load—100% floor loading—115% roof snow loading. Connector capacity depends on the model selected, quantity and size of nails used, and the size and type of fastener support. Stated capacity is based on manufacturer's required nailing. Douglas Fir-Larch or Southern Pine web filler has been assumed for all I-joist series and depths except for all WI 80 and GPI 90 depths where SPF has been used. Higher capacities may be available based on different header materials; please refer to appropriate reference/design guide from the connector manufacturer for expanded design information. Some connector/header/fastener combinations may not meet maximum joist reaction capacities and a qualified designer should be consulted. VPA and TMP connectors are based on SPF wood plates. Clinch nails across grain when possible.
- Top mount hanger capacities shown are based on the same series and depth of Wood I Beam™ joists carried. To achieve design capacity shown, use 10d nails for single 1 3/4" thick GP Lam® LVL beams and 16d nails for double 1 3/4" thick (3 1/2") GP LVL, Douglas Fir-Larch or Southern Pine glulam beams. Refer to detail F12.
- Hanger capacities are based on the lesser value of single 1 3/4" thick GP Lam LVL, Douglas Fir-Larch or Southern Pine Glulam beams or the same series and depth of Wood I Beam joists carried. Refer to detail F13 and R1.

- Bearing stiffeners required for Wood I Beam applications. Refer to details F13 and F18.
- Beveled bearing stiffeners are required. Refer to detail R8. Maximum slope is 12/12. A tie strap is required for all Wood I Beam applications with slopes of 3/12 and greater. Refer to detail R1.
- TMP connectors may be used for slopes of 1/12 through 6/12. For greater slopes use TMPH series connectors with bearing stiffeners.
- Nailing key. "H" column indicates size of nails to connect hanger to supporting header. "J" column indicates nails to attach the hanger to the joist. "P" indicates nails to connect to plate. Fill all nail holes as required by hanger manufacturer. Nails 10d x 1 1/2" are 0.148" x 1 1/2" long, 10d nails are 0.148" x 3" long and 16d are 0.162" x 3 1/2" long.

NOTE: Model numbers shown are for United Steel Products Company, Inc. 1-800-328-5934 and Simpson Strong-Tie® Company, Inc. 1-800-999-5099. Some locations carry similar products produced by other manufacturers. Contact your local building material retailer for conversion information and details. Other designs are available for specialized applications.

Design Properties for Wood I Beam™ Joists

Joist Series	Joist Depth	EI (10 ⁶ in ² -lbs)	Allowable Moment ^{a,b} (ft-lbs)	Allowable Shear ^b (lbs)	Allowable Reactions		C (10 ⁶ ft-lbs/in)	Weight ^e (lbs/ft)
					End ^{b,c} (lbs)	Intermediate ^{b,d} (lbs)		
GPI 20	9½"	159	3000	1135	1050	2340	0.412	2.3
	11⅞"	274	3870	1435	1100	2340	0.515	2.6
	14"	409	4640	1710	1150	2340	0.607	2.9
GPI 40	9½"	193	3090	1200	1120	2600	0.412	2.9
	11⅞"	330	3990	1460	1225	2600	0.515	3.1
	14"	482	4790	1715	1250	2600	0.607	3.5
GPI 65	11⅞"	434	6325	1495	1230	2610	0.515	3.1
	14"	640	7605	1740	1335	2610	0.607	3.5
	16"	877	8755	2000	1345	2610	0.693	3.7
GPI 90	11⅞"	661	10255	1925	1400	3355	0.515	4.1
	14"	965	12235	2125	1400	3355	0.607	4.4
	16"	1306	14020	2330	1400	3355	0.693	4.8
WI 40	9½"	193	2735	1120	1080	2160	0.412	2.6
	11⅞"	330	3545	1420	1200	2500	0.515	2.9
	14"	482	4270	1710	1200	2500	0.607	3.3
WI 60	11⅞"	396	4900	1420	1200	2500	0.515	3.2
	14"	584	5895	1710	1200	2500	0.607	3.4
	16"	799	6835	1970	1200	2500	0.693	3.7
WI 80	11⅞"	547	6940	1420	1280	2760	0.515	3.9
	14"	802	8360	1710	1280	3020	0.607	4.2
	16"	1092	9690	1970	1280	3020	0.693	4.5

NOTES:

- a. Allowable moment may not be increased for any code allowed repetitive member use factor.
- b. Allowable moment, shear, and reaction values are for normal duration loading and may be increased for other load durations in accordance with code.
- c. Allowable end reaction is based on a minimum bearing length of 1¼" without bearing stiffeners. For a bearing length of 4", the allowable end reaction may be set equal to the tabulated shear value. Interpolation of the end reaction between 1¼" and 4" bearing is permitted. For end reaction values over 1550 lbs. (1900 lbs. for GPI 90), bearing stiffeners are required.
- d. Allowable intermediate reaction is based on a minimum bearing length of 3½".
- e. Weight of joists for dead load calculations. For shipping weights contact Georgia-Pacific at 800-284-5347.

$$\text{APPROXIMATE DEFLECTION* (Inches)} = \frac{22.5 \times W \times L^4}{EI} + \frac{W \times L^2}{C}$$

W = Uniform Load (lbs/foot)
 L = Span (feet)
 EI = Stiffness Constant (in²-lbs)
 C = Shear Deflection Constant (ft-lbs/in)

*Constants have been adjusted to maintain unit consistency.

Plumbing Details

P1 JOIST SPACING BELOW PLUMBING WALL
Parallel to wall

Joist	2x4 Wall	2x6 Wall
GPI 20	5¼"	7¼"
GPI 40 and 65 WI 40 and 60	6"	8"
GPI 90/WI 80	7"	9"

Non-load bearing wall only

Every third joist may be shifted up to 3" to avoid plumbing interference.

*Provide blocking between adjacent joists when needed to support panel ends.

P2 JOIST SPACING BELOW PLUMBING

Every third joist may be shifted up to 3" to avoid plumbing interference.

May not be appropriate for some sheathing and finished flooring applications.

Wood I Beam™ Joist Architectural Specifications

Part 1—General

1.0—Description:

- A. Work in this section includes, but is not limited to: Prefabricated Wood I Beam™ GPI 20, GPI 40, GPI 65, GPI 90, WI 40, WI 60 and WI 80 ceiling, floor, and roof joists with enhanced OSB webs and lumber flanges (WI) or LVL flanges (GPI).
- B. Related work specified elsewhere: Rough carpentry.

1.1—Submittals:

- A. Product data: Submit manufacturer's descriptive literature indicating material composition, thicknesses, dimensions, loading and fabrication details.
- B. Shop drawings or installation guide: Manufacturer's literature indicating installation details. Include locations and details of bearing, blocking, bridging, and cutting and drilling of webs for work by others.

1.2—Quality Assurance:

- A. Certification: All Georgia-Pacific Wood I Beam joists have been qualified to ASTM D 5055 by APA-The Engineered Wood Association.

1.3—Delivery, Storage and Handling:

- A. Delivery: Deliver materials to the job site in manufacturer's original packaging, containers and bundles with manufacturer's brand name and identification intact and legible.
- B. Storage and handling: Store and handle materials to protect against contact with damp and wet surfaces, exposure to weather, breakage and damage. Provide air circulation under covering and around stacks of materials. Individual joists shall be handled in the upright position.

1.4—Limitations:

- A. Loads: Concentrated loads shall not be applied to the bottom flange.
- B. Cutting: Except for cutting to length and birdsmouth cuts, top and bottom flanges of Wood I Beam floor and roof joists shall not be cut, drilled or notched.
- C. Wood I Beam joists are for use in covered, dry-use conditions only (moisture content less than 16%).

Part 2—Products

2.0—Prefabricated Joists:

- A. Acceptable products:
 1. Georgia-Pacific, WI 40.
 2. Georgia-Pacific, WI 60.
 3. Georgia-Pacific, WI 80.
 4. Georgia-Pacific, GPI 20.
 5. Georgia-Pacific, GPI 40.
 6. Georgia-Pacific, GPI 65.
 7. Georgia-Pacific, GPI 90.

B. Characteristics:

1. Flanges:
 - Lumber flanges (width).
 - a. WI 40 (2½").
 - b. WI 60 (2½").
 - c. WI 80 (3½").
 - LVL flanges (width).
 - a. GPI 20 (1¾").
 - b. GPI 40 (2⅝").
 - c. GPI 65 (2⅝").
 - d. GPI 90 (3½").
2. Webs: ⅜" minimum thickness FiberStrong® OSB web.
3. Beam depths as required for loading, deflection, and span:
 - a. GPI 20 (9½", 11⅞", and 14")
 - b. GPI 40 or WI 40 (9½", 11⅞", and 14")
 - c. WI 60 (11⅞", 14" and 16")
 - d. GPI 65 (11⅞", 14" and 16")
 - e. WI 80 (11⅞", 14" and 16")
 - f. GPI 90 (11⅞", 14" and 16")
4. Beam length as required for span and bearing.

2.1—Accessories:

- A. Nails: 8d, 10d, and 12d box, sinker, and common nails.
- B. Bracing and blocking:
 1. Bearing stiffeners: 2x4 or combination of ⅜", ½" or ⅝" Plywood Sturd-I-Floor® or OSB.
 2. Band joists and continuous closure at load-bearing walls: per standard approved Wood I Beam details.
 3. Lateral support at intermediate bearing of multiple span joists: Wood I Beam blocking.
- C. Joist hangers:
 1. Model numbers are shown for United Steel Products and Simpson Strong-Tie® connectors. Contact Georgia-Pacific for other acceptable connectors.

Part 3—Execution

3.0—General:

- A. Provide Wood I Beam floor and roof joists where indicated on drawings using hangers and accessories specified.
- B. Install Wood I Beam joists in accordance with manufacturer's recommendations.
- C. Install and brace Wood I Beam floor and roof joists to prevent dominoing of system and buckling of top flange.

3.1—Accessories:

Install accessories where indicated and in accordance with manufacturer's instructions.

ENGINEERED FOR PERFORMANCE

What you don't see matters.™
Build it better.®



When it comes to floor joists, rim board, beams and headers, builders and contractors choose Georgia-Pacific engineered lumber for many reasons. Today's residential building trends call for large, open spaces and high ceilings, creating a demand for products that provide higher strength and greater stability over longer spans.

Georgia-Pacific engineered lumber provides the following benefits:

- More open spaces
- Quieter floors
- A flat, level, more stable floor system
- Lifetime limited warranty*

For more information, call 877-437-9759 or visit www.gp.com/build.

SALES, UPDATES AND CURRENT INFORMATION

The sale of our engineered lumber products is subject to our terms of sale which are available at www.gp.com/tc or upon request. The information in this document may change without notice. Visit our website at www.gp.com/build for updates and current information or call 800-284-5347 to request a current copy.

GENERAL

The user is responsible for proper installation of our engineered lumber products. Our engineered lumber products must be installed in strict conformity with our instructions and all applicable building code requirements and other regulations. In addition, if not specifically covered by our installation instructions or construction detail illustrations, the products must be installed in accordance with generally accepted design and construction practices. When installing engineered lumber products, the user must also consider the effects of local climate and geography. We do not warrant and are not responsible for the design and construction of any finished structure or system into which our engineered lumber products may be incorporated or other building components that may be used with our products.

LIMITATION OF REMEDIES AND DAMAGES

EXCEPT AS EXPRESSLY STATED IN OUR LIFETIME LIMITED WARRANTY, WE DO NOT MAKE AND HEREBY EXPRESSLY DISCLAIM, ANY AND ALL OTHER REPRESENTATIONS AND WARRANTIES OF ANY KIND WHATSOEVER, EXPRESS OR IMPLIED, INCLUDING BUT NOT LIMITED TO WARRANTIES OF OR AS TO MERCHANTABILITY OR FITNESS FOR A PARTICULAR PURPOSE. THE EXCLUSIVE REMEDIES FOR BREACH OF WARRANTY, AND AT GP'S SOLE OPTION, ARE REPAIR OF AFFECTED PRODUCT, REPLACEMENT OF AFFECTED PRODUCT OR REIMBURSEMENT OF THE REASONABLE COST OF REPAIR OR REPLACEMENT OF THE AFFECTED PRODUCT. WE SHALL NOT BE RESPONSIBLE UNDER ANY CIRCUMSTANCES FOR LOST PROFITS, DAMAGE TO A STRUCTURE IN WHICH THE AFFECTED PRODUCT IS INSTALLED, DAMAGE TO OTHER PROPERTY OR ANY OTHER INDIRECT, INCIDENTAL, EXEMPLARY, SPECIAL, CONSEQUENTIAL OR PUNITIVE DAMAGES. IN NO EVENT, REGARDLESS OF THE FORM OF THE CLAIM OR CAUSE OF ACTION, OUR CUMULATIVE LIABILITY TO BUYER SHALL NOT EXCEED THE PURCHASE PRICE FOR THE SPECIFIC PRODUCT GIVING RISE TO THE CLAIM OR CAUSE OF ACTION. WARRANTY CLAIMS SHALL BE

DEEMED WAIVED IF THEY ARE NOT SUBMITTED TO US IN WRITING WITHIN THIRTY (30) DAYS AFTER DISCOVERY. OUR ENGINEERED LUMBER PRODUCTS MAY SUPPORT MOLD GROWTH IF EXPOSED TO CERTAIN CONDITIONS, INCLUDING MOISTURE, DAMPNES, CONDENSATION, HUMIDITY, WATER OR WET CONDITIONS. MOLD, MILDEW, FUNGI, ALGAE, MOSS, BACTERIAL GROWTH, DECAY, ROT OR SIMILAR CONDITIONS ARE NOT MANUFACTURING OR PRODUCT DEFECTS AND WE ASSUME NO RESPONSIBILITY OR LIABILITY FOR SUCH CONDITIONS, REGARDLESS OF CAUSE.

HEALTH AND SAFETY CAUTION

Georgia-Pacific engineered lumber products are manufactured with one or more of the following adhesives: phenol-formaldehyde, phenol-resorcinol-formaldehyde, melamine and/or polyurethane. Formaldehyde emissions from products with these adhesives are considered close to background levels and current regulations do not generally require emission measurements. A Material Safety Data Sheet (MSDS) containing potential physical and health hazard information is available from your employer or by contacting the Products Safety and Health Information Department at Georgia-Pacific LLC, P.O. Box 105605, Atlanta, GA 30348-5605, 404-652-5119 or visit www.gp.com/build.



Georgia-Pacific Wood Products LLC
133 Peachtree Street, 14th Floor
Atlanta, GA 30303
877-437-9759

* See manufacturer's warranty for terms, conditions and limitations (www.gp.com/build).

Georgia-Pacific, GP, the GP logo, Wood I Beam logo, Wood I Beam, GP Lam, FiberStrong, What you don't see matters, and Build It Better are owned by or licensed to Georgia-Pacific Wood Products LLC.
©2012 Georgia-Pacific Wood Products LLC. All rights reserved. Printed in the U.S.A. 3/12 GEO-TM Lit. Item #123040 (pgs. 4-30)