

service



i n v e n t

A large, white HP LaserJet printer with a built-in scanner and automatic document feeder (ADF). The scanner lid is open, and the printer is positioned in an office setting with windows in the background.

Scanner/ADF for the  
**hp** LaserJet  
9000mfp/9000Lmfp/9040mfp/9050mfp  
and  
**hp** color LaserJet 9500mfp



# Scanner/ADF service manual for the HP LaserJet 9000mfp/9000Lmfp/9040mfp/ 9050mfp/9500mfp

## **service** \_\_\_\_\_

This manual is used in conjunction with the  
*HP LaserJet 9000 and 9050 Printer Service Manual*, and the  
*HP Color LaserJet 9500/9500mfp Print Engine Service Manual*.

© 2004 Copyright Hewlett-Packard Development Company, L.P.

Reproduction, adaptation, or translation without prior written permission is prohibited, except as allowed under the copyright laws.

Part number: C8549-90955

Edition 1, 9/2004

The information contained in this document is subject to change without notice.

The only warranties for HP products and services are set forth in the express warranty statements accompanying such products and services. Nothing herein should be construed as constituting an additional warranty. HP shall not be liable for technical or editorial errors or omissions contained herein.

## Trademark Credits

Adobe® and PostScript® are trademarks of Adobe Systems Incorporated.

Microsoft®, MS-DOS®, and Windows® are U.S. registered trademarks of Microsoft Corporation.

TrueType™ is a U.S. trademark of Apple Computer, Inc.

UNIX® is a registered trademark of The Open Group.

Energy Star® is a U.S. registered service mark of the United States Environmental Protection Agency.



# Table of contents

## List of tables

## List of figures

### 1

#### MFP requirements

Space requirements HP LJ 9000mfp/9000Lmfp/9040mfp/9050mfp	18
Space requirements HP LJ 9500mfp	20

### 2

#### MFP information

MFP specifications	22
MFP features	22
Identification	22
Specifications	23
Interface connections	26
Regulatory information	28
Service approach	28
Parts and supplies	28
Warranty	28
Limited warranty for the print cartridge	28
Service and support	29

### 3

#### MFP configuration

Control panel	32
Control panel layout HP LJ 9000mfp/9000Lmfp	32
Touch-screen graphical display layout HP LJ 9000mfp/9000Lmfp	33
Control panel layout HP LJ 9040mfp/9050mfp/9500mfp	34
Touch-screen display layout HP LJ 9040mfp/9050mfp/9500mfp	35
Settings and defaults	36
Setting the display language	36
Setting tray registration	36
E-mail settings	38
FAX settings (HP LaserJet 9040mfp/9050mfp/9500mfp)	39
Color copy settings (HP LaserJet 9500mfp)	40
Control panel menus (LJ 9000mfp/9000Lmfp/9040mfp/9050mfp)	41
Menu map (LJ 9000mfp/9000Lmfp/9040mfp/9050mfp)	41
Using a menu map (LJ 9000mfp/9000Lmfp/9040mfp/9050mfp)	41
Retrieve job menu (LJ 9000mfp/9000Lmfp/9040mfp/9050mfp)	42
If you select PRINT, the printer prompts you to specify the number of copies to print (1 to 32,000)	42
Information menu (LJ 9000mfp/9000Lmfp/9040mfp/9050mfp)	42
Paper handling menu (LJ 9000mfp/9000Lmfp/9040mfp/9050mfp)	43
Configure device menu (LJ 9000mfp/9000Lmfp/9040mfp/9050mfp)	45
Printing submenu (LJ 9000mfp/9000Lmfp/9040mfp/9050mfp)	45
PCL submenu	47

Print-quality submenu (LJ 9000mfp/9000Lmfp/9040mfp/9050mfp)	.48
System setup submenu (LJ 9000mfp/9000Lmfp/9040mfp/9050mfp)	.50
I/O submenu (LJ 9000mfp/9000Lmfp/9040mfp/9050mfp)	.52
EIO X Jetdirect submenu (LJ 9000mfp/9000Lmfp/9040mfp/9050mfp)	.53
Resets submenu (LJ 9000mfp/9000Lmfp/9040mfp/9050mfp)	.57
Diagnostics menu (HP LJ 9000mfp/9000Lmfp/9040mfp/9050mfp)	.58
Service menu (HP LJ 9000mfp/9000Lmfp/9040mfp/9050mfp)	.58
Control panel menus (HP CLJ 9500mfp)	.59
Menu map (CLJ 9500mfp)	.59
Using a menu map (CLJ 9500mfp)	.59
Retrieve job menu (CLJ 9500mfp)	.60
Information menu (CLJ 9500mfp)	.61
Paper handling menu (CLJ 9500mfp)	.62
Configure device menu (CLJ 9500mfp)	.64
Printing submenu (CLJ 9500mfp)	.68
PCL submenu (CLJ 9500mfp)	.70
Print quality submenu (CLJ 9500mfp)	.72
System setup submenu (CLJ 9500mfp)	.74
I/O submenu (CLJ 9500mfp)	.77
Resets submenu (CLJ 9500mfp)	.81
Diagnostics menu (CLJ 9500mfp)	.82
Service menu (CLJ 9500mfp)	.85
Installing firmware updates	.87
Downloading the new firmware to the MFP	.87
Remote firmware update through a local Windows port	.88
Remote firmware update through a Windows network	.89
Remote firmware update for UNIX systems	.89
Remote firmware update by using FTP on a direct network connection	.90
Remote firmware update by using FTP through a browser	.91
Remote firmware update using the HP LaserJet utility (Mac OS 8.6 and 9.x only)	.92
Remote firmware update using the LPR command	.93
Using HP Web Jetadmin to download the firmware to the MFP	.93
MFP messages during firmware update	.94
Troubleshooting a firmware update	.95

## 4 MFP maintenance

Cleaning the MFP and accessories	.98
General cleaning	.98
ADF cleaning	.99
Glass cleaning	.105

## 5 Theory of operation

Differences in MFPs	.108
Mechanical structure	.110
Motors and fans	.112
Basic block diagram	.114
Basic system configuration	.115
Scanner unit systems	.115
Scan mode	.116
Power supply assembly	.117
PowerSave (sleep) mode (HP LJ 9000mfp/9000Lmfp)	.119
Sleep mode (HP LJ 9040mfp/9050mfp/9500mfp)	.120
Low-voltage power supply circuit	.122
Scanner controller circuit	.124

Flatbed operation . . . . .	125
Flatbed document exposure control . . . . .	125
Flatbed optical drive control . . . . .	126
Flatbed optical unit operation . . . . .	127
Flatbed document size detection . . . . .	128
ADF operation . . . . .	131
ADF document exposure control . . . . .	131
ADF document feed control . . . . .	132
ADF document size detection . . . . .	134
ADF feeder sensors . . . . .	135
ADF document skew detection . . . . .	136
Scanned data flow . . . . .	137
Copy processor . . . . .	138
Scanning process control signals . . . . .	139
Typical scanning process flow . . . . .	139
Copy processor LEDs (HP LJ 9000mfp/9000Lmfp) . . . . .	140
Copy processor LEDs (HP LJ 9040mfp/9050mfp/9500mfp) . . . . .	142

## 6 Removal and replacement

Introduction . . . . .	147
Removal and replacement strategy . . . . .	147
Electrostatic discharge . . . . .	147
Required tools . . . . .	147
External covers . . . . .	148
Control panel (HP LJ 9000mfp/9000Lmfp) . . . . .	148
Control panel (HP LJ 9040mfp/9050mfp/9500mfp) . . . . .	150
ADF feeder cover . . . . .	151
ADF feeder cover handle . . . . .	153
ADF back cover . . . . .	154
ADF front cover . . . . .	155
Lower delivery roller cover . . . . .	156
White board cover . . . . .	157
Copy processor/connect board . . . . .	158
Flatbed rail cover . . . . .	159
Flatbed back cover . . . . .	160
Flatbed right cover . . . . .	161
Flatbed left cover . . . . .	162
Flatbed upper front cover . . . . .	163
Flatbed lower front cover . . . . .	164
ADF base cover assembly . . . . .	165
Glass . . . . .	170
Internal . . . . .	172
ADF main assembly . . . . .	172
ADF optical assembly . . . . .	177
ADF scanning lamp (HP LJ 9000mfp/9000Lmfp) . . . . .	184
ADF shading filter . . . . .	187
Flatbed optical unit . . . . .	188
Flatbed scanning lamp (HP LJ 9000mfp/9000Lmfp) . . . . .	191
Switch and solenoids . . . . .	193
ADF feeder cover detection switch . . . . .	193
Weight solenoid . . . . .	194
Shutter solenoid . . . . .	195

Motors and fans . . . . .	196
Pickup motor . . . . .	196
Delivery motor . . . . .	198
Flatbed motor . . . . .	200
Power supply assembly . . . . .	202
ADF fan assembly . . . . .	205
Flatbed fan assembly . . . . .	206
PCB assemblies . . . . .	207
ADF analog processor PCB (HP LJ 9000mfp/9000Lmfp only) . . . . .	207
ADF inverter PCB (HP LJ 9000mfp/9000Lmfp only) . . . . .	208
ADF intermediate PCB . . . . .	209
ADF width detection sensor assembly . . . . .	210
Flatbed inverter PCB (HP LJ 9000mfp/9000Lmfp only) . . . . .	211
Flatbed intermediate PCB . . . . .	212
Scanner controller board . . . . .	214
Intermediate PCB assembly . . . . .	217
Power supply assembly . . . . .	219
Rollers and belts . . . . .	222
Pickup roller (D-roller) . . . . .	222
Pickup roller assembly . . . . .	223
Feed roller assembly . . . . .	224
Lower registration roller assembly . . . . .	225
Lower delivery roller . . . . .	231
Upper delivery roller assembly . . . . .	232
Separation belt assembly . . . . .	233
Separation belts . . . . .	236
Scan engine . . . . .	238

## 7 Troubleshooting

Troubleshooting process . . . . .	245
Preliminary operating checks . . . . .	246
Power on . . . . .	247
Power-on defects . . . . .	247
Malfunction troubleshooting . . . . .	248
Troubleshooting with control panel messages . . . . .	249
Control panel display . . . . .	249
Event log page . . . . .	249
Control panel messages . . . . .	252
MFP message tables . . . . .	253
Alphabetic error messages . . . . .	253
Numeric error messages . . . . .	255
Troubleshooting with the copy processor . . . . .	260
HP LJ 9000mfp/9000Lmfp . . . . .	260
HP LJ 9040mfp/9050mfp/9500mfp . . . . .	262
User- and service-level diagnostics . . . . .	264
Diagnostics . . . . .	264
Service test (HP LJ 9000mfp/9000Lmfp/9040mfp/9050mfp) . . . . .	265
Service-level diagnostics . . . . .	266
Service menu . . . . .	266
Calibrations . . . . .	268
Control-panel touch screen calibration (HP LJ 9000mfp/9000Lmfp) . . . . .	268
Control-panel touch screen calibration (HP LJ 9040mfp/9050mfp/9500mfp) . . . . .	270
Scanner/ADF calibration simplified . . . . .	271
ADF calibrations . . . . .	274
Glass calibrations . . . . .	282

Measurement and adjustment . . . . .	287
ADF unit height adjustment . . . . .	287
ADF skew adjustment . . . . .	289
ADF width sensor adjustment . . . . .	291
Weight solenoid stroke adjustment . . . . .	292
Jam troubleshooting . . . . .	293
Jams . . . . .	293
Evaluating the information pages . . . . .	295
Configuration page . . . . .	295
Jetdirect page . . . . .	297
Supplies status page . . . . .	298
Usage page . . . . .	299
File directory page . . . . .	300
Image-formation troubleshooting . . . . .	301
Copy-image defects . . . . .	302
Scanner controller PCB . . . . .	309
Connector locations . . . . .	310
Electrical structure . . . . .	311
Wiring diagrams . . . . .	312

## 8 Parts and diagrams

Introduction . . . . .	316
Ordering parts . . . . .	316
Consumables (HP LJ 9000mfp/9000Lmfp9040mfp/9050mfp) . . . . .	317
Consumables (HP CLJ 9500mfp) . . . . .	322
Common hardware . . . . .	326
Illustrations and parts lists . . . . .	327
MFP system assembly . . . . .	328
External panels and covers . . . . .	329
Flatbed scanner assembly . . . . .	332
Flatbed optical assembly . . . . .	337
ADF scanner assembly . . . . .	339
Paper pickup assembly . . . . .	342
ADF main assembly . . . . .	347
ADF optical assembly . . . . .	350
PCB assemblies . . . . .	352
Alphabetical parts list . . . . .	353
Numerical parts list . . . . .	358

## Index



# List of tables

Table 1. Electrical specifications	23
Table 2. Environmental specifications HP LJ 9000mfp/9000Lmfp	24
Table 3. Environmental specifications HP LJ 9040mfp/9050mfp	24
Table 4. Environmental specifications HP LJ 9500mfp	24
Table 5. Noise level specifications HP LJ 9000mfp/9000Lmfp	24
Table 6. Noise level specifications HP LJ 9040mfp/9050mfp	24
Table 7. Noise level specifications HP LJ 9500mfp	25
Table 8. Skew specifications	25
Table 9. Control panel features, and key functions	32
Table 10. Touch-screen graphical display features and functions	33
Table 11. Touch-screen graphical display features and functions	35
Table 12. Color copy settings (HP LaserJet 9500mfp)	40
Table 13. Information menu (LJ 9000mfp/9000Lmfp/9040mfp/9050mfp)	42
Table 14. Information menu (LJ 9000mfp/9000Lmfp/9040mfp/9050mfp)	43
Table 15. Printing submenu (LJ 9000mfp/9000Lmfp/9040mfp/9050mfp)	45
Table 16. PCL submenu (LJ9000mfp/9000Lmfp/9040mfp/9050mfp)	47
Table 17. print-quality submenu (LJ 9000mfp/9000Lmfp/9040mfp/9050mfp)	48
Table 18. System setup submenu (LJ 9000mfp/9000Lmfp/9040mfp/9050mfp)	50
Table 19. I/O timeout submenu (LJ 9000mfp/9000Lmfp/9040mfp/9050mfp)	52
Table 20. Parallel input submenu (LJ 9000mfp/9000Lmfp/9040mfp/9050mfp)	52
Table 21. EIO X Jetdirect submenu (LJ 9000mfp/9000Lmfp/9040mfp/9050mfp)	53
Table 22. Diagnostics menu (HP LJ 9000mfp/9000Lmfp9040mfp/9050mfp)	58
Table 23. Service menu (HP LJ 9000mfp/9000Lmfp9040mfp/9050mfp)	58
Table 24. Retrieve job menu (CLJ 9500mfp)	60
Table 25. Information menu (CLJ 9500mfp)	61
Table 26. Paper handling menu settings (CLJ 9500mfp)	62
Table 27. Originals submenu (CLJ 9500mfp)	64
Table 28. Copying submenu (CLJ 9500mfp)	65
Table 29. Enhancement submenu (CLJ 9500mfp)	66
Table 30. Sending submenu (CLJ 9500mfp)	66
Table 31. E-mail submenu (CLJ 9500mfp)	67
Table 32. Printing submenu (CLJ 9500mfp)	68
Table 33. PCL submenu (CLJ 9500mfp)	70
Table 34. Print quality submenu (CLJ 9500mfp)	72
Table 35. System setup submenu (CLJ 9500mfp)	74
Table 36. I/O submenu (CLJ 9500mfp)	77
Table 37. EIO submenu (CLJ 9500mfp)	78
Table 38. Resets submenu (CLJ 9500mfp)	81
Table 39. Diagnostics menu (CLJ 9500mfp)	82
Table 40. Service menu (CLJ 9500mfp)	85
Table 41. MFP messages during firmware update	94
Table 42. Troubleshooting a firmware update (1 of 2)	95
Table 43. Troubleshooting a firmware update (2 of 2)	95
Table 44. Differences between the LJ 9000mfp/9000Lmfp and the LJ 9040mfp/9050mfp	108
Table 45. Differences between the LJ 9000mfp/9000Lmfp and the CLJ 9500mfp	108
Table 46. Differences between the LJ 9040mfp/9050mfp and the CLJ 9500mfp	109
Table 47. Mechanical structure	110
Table 48. Mechanical structure	111
Table 49. Motors and fans	113

Table 50. Electrical specifications	117
Table 51. Powersave mode (HP LJ 9000mfp/9000Lmfp)	119
Table 52. System behavior in sleep mode	120
Table 53. Copy processor LEDs (HP LJ 9000mfp/9000Lmfp)	140
Table 54. Copy processor LEDs (HP LJ 9040mfp/9050mfp/9500mfp)	142
Table 55. Primary steps for troubleshooting	245
Table 56. Power-on defects or blank display	247
Table 57. Malfunction troubleshooting	248
Table 58. Alphabetic error messages	253
Table 59. Numeric error messages	255
Table 60. Troubleshooting copy processor board LEDs	261
Table 61. Copy processor LEDs (HP LJ 9040mfp/9050mfp/9500mfp)	262
Table 62. Replaced components and required calibrations	268
Table 63. Scanner calibration values	273
Table 64. ADF motor speed calibration values	286
Table 65. General jam troubleshooting	293
Table 66. General jam troubleshooting	294
Table 67. Image quality checks	301
Table 68. ADF simplex (front side)	303
Table 69. ADF duplex (second side)	304
Table 70. Flatbed glass	306
Table 71. All scan locations	307
Table 72. Sensors	311
Table 73. Consumables, supplies, accessories, FRUs, and documentation	317
Table 74. Kits and supplies	322
Table 75. Accessories, exchange parts, and documentation	322
Table 76. Hardware table	326
Table 77. Common torque values	326
Table 78. MFP system assembly	328
Table 79. External panels and covers	331
Table 80. Flatbed scanner assembly	335
Table 81. Flatbed optical assembly	338
Table 82. ADF scanner assembly	340
Table 83. Paper pickup assembly	344
Table 84. ADF main assembly	348
Table 85. ADF optical assembly	351
Table 86. PCB assemblies	352
Table 87. Alphabetical parts list	353
Table 88. Numerical parts list	358

# List of figures

Figure 1. MFP space requirements with a finishing device (HP LJ 9000mfp/9000Lmfp/9040mfp/9050mfp) . . . . .	18
Figure 2. MFP space requirements with a finishing device (HP LJ 9000mfp/9000Lmfp/9040mfp/9050mfp) . . . . .	19
Figure 3. MFP space requirements with a finishing device (HP LJ 9500mfp) (top and front view) . . . . .	20
Figure 4. Sample identification label from an HP LaserJet 9000mfp/9000Lmfp . . . . .	22
Figure 5. Interface connections HP LJ 9000mfp/9000Lmfp . . . . .	26
Figure 6. Interface connections HP LJ 9040mfp/9050lmp . . . . .	26
Figure 7. Interface connections HP LJ 9500mfp . . . . .	27
Figure 8. Control panel layout HP LJ 9000mfp/9000Lmfp . . . . .	32
Figure 9. Touch-screen graphical display layout HP LJ 9000mfp/9000Lmfp . . . . .	33
Figure 10. Control panel layout HP LJ 9040mfp/9050mfp/9500mfp . . . . .	34
Figure 11. Touch-screen graphical display layout HP LJ 9040mfp/9050mfp/9500mfp . . . . .	35
Figure 12. Registration page (HP LJ 9000 Series printer shown) (1 of 2) . . . . .	37
Figure 13. Registration page (HP LJ 9000 Series printer shown) (2 of 2) . . . . .	37
Figure 14. ADF delivery system (1 of 5) . . . . .	99
Figure 15. ADF delivery system (2 of 5) . . . . .	99
Figure 16. ADF delivery system (3 of 5) . . . . .	100
Figure 17. ADF delivery system (4 of 5) . . . . .	100
Figure 18. ADF delivery system (5 of 5) . . . . .	100
Figure 19. Upper ADF glass strip (1 of 4) . . . . .	101
Figure 20. Upper ADF glass strip (2 of 4) . . . . .	101
Figure 21. Upper ADF glass strip (3 of 4) . . . . .	102
Figure 22. Upper ADF glass strip (4 of 4) . . . . .	102
Figure 23. ADF rollers (1 of 6) . . . . .	103
Figure 24. ADF rollers (2 of 6) . . . . .	103
Figure 25. ADF rollers (3 of 6) . . . . .	103
Figure 26. ADF rollers (4 of 6) . . . . .	104
Figure 27. ADF rollers (5 of 6) . . . . .	104
Figure 28. ADF rollers (6 of 6) . . . . .	104
Figure 29. Mechanical structure (1 of 2) . . . . .	110
Figure 30. Mechanical structure (2 of 2) . . . . .	111
Figure 31. Motors and fans . . . . .	112
Figure 32. Basic block diagram for the HP LJ 9000mfp/9000Lmfp . . . . .	114
Figure 33. Basic block diagram for the HP LJ 9040mfp/9050mfp and the HP CLJ 9500mfp . . . . .	114
Figure 34. Basic system configuration . . . . .	116
Figure 35. Power supply assembly . . . . .	118
Figure 36. HP LJ 9000mfp/9000Lmfp . . . . .	119
Figure 37. Low-voltage power supply circuit . . . . .	122
Figure 38. Printer power supply . . . . .	123
Figure 39. Scanner controller circuit . . . . .	124
Figure 40. Flatbed document exposure control . . . . .	125
Figure 41. Flatbed optical drive control . . . . .	126
Figure 42. Flatbed optical unit operation . . . . .	127
Figure 43. Flatbed document size detection . . . . .	128
Figure 44. Functions operation . . . . .	129
Figure 45. ADF angle detection . . . . .	130
Figure 46. ADF document exposure control . . . . .	131
Figure 47. ADF document feed control . . . . .	132
Figure 48. ADF document size detection . . . . .	134
Figure 49. ADF feeder sensors . . . . .	135

Figure 50. Document skew jam . . . . .	136
Figure 51. Scanned data flow. . . . .	137
Figure 52. Example of a copy processor (HP LJ 9000mfp/9000Lmfp shown) . . . . .	138
Figure 53. Copy processor LEDs (HP LJ 9000mfp/9000Lmfp) . . . . .	140
Figure 54. Copy processor LEDs (HP LJ 9040mfp/9050mfp/9500mfp) . . . . .	142
Figure 55. Control panel (HP LJ 9000mfp/9000Lmfp) (1 of 3) . . . . .	148
Figure 56. Control panel (HP LJ 9000mfp/9000Lmfp) (2 of 3) . . . . .	148
Figure 57. Control panel (HP LJ 9000mfp/9000Lmfp) (3 of 3) . . . . .	149
Figure 58. Control panel (HP LJ 9040mfp/9050mfp/9500mfp) (1 of 3) . . . . .	150
Figure 59. Control panel (HP LJ 9040mfp/9050mfp/9500mfp) (2 of 3) . . . . .	150
Figure 60. ADF feeder cover (1 of 3) . . . . .	151
Figure 61. ADF feeder cover (2 of 3) . . . . .	151
Figure 62. ADF feeder cover (3 of 3) . . . . .	152
Figure 63. ADF feeder cover handle (1 of 2) . . . . .	153
Figure 64. ADF feeder cover handle (2 of 2) . . . . .	153
Figure 65. ADF back cover (1 of 2) . . . . .	154
Figure 66. ADF back cover (2 of 2) . . . . .	154
Figure 67. ADF front cover . . . . .	155
Figure 68. Delivery roller cover. . . . .	156
Figure 69. White board cover . . . . .	157
Figure 70. Copy processor board (HP LJ 9000mfp/9000Lmfp shown) . . . . .	158
Figure 71. Flatbed rail cover. . . . .	159
Figure 72. Flatbed back cover (1 of 2) . . . . .	160
Figure 73. Flatbed back cover (2 of 2) . . . . .	160
Figure 74. Flatbed right cover (1 of 2) . . . . .	161
Figure 75. Flatbed right cover (2 of 2) . . . . .	161
Figure 76. Flatbed left cover (1 of 2) . . . . .	162
Figure 77. Flatbed left cover (2 of 2) . . . . .	162
Figure 78. Flatbed upper front cover . . . . .	163
Figure 79. Flatbed lower front cover. . . . .	164
Figure 80. ADF base cover assembly (1 of 9) . . . . .	165
Figure 81. ADF base cover assembly (2 of 9) . . . . .	165
Figure 82. ADF base cover assembly (3 of 9) . . . . .	166
Figure 83. ADF base cover assembly (4 of 9) . . . . .	166
Figure 84. ADF base cover assembly (5 of 9) . . . . .	167
Figure 85. ADF base cover assembly (6 of 9) . . . . .	167
Figure 86. ADF base cover assembly (7 of 9) . . . . .	168
Figure 87. ADF base cover assembly (8 of 9) . . . . .	168
Figure 88. ADF base cover assembly (9 of 9) . . . . .	169
Figure 89. Glass (1 of 2). . . . .	170
Figure 90. Glass (2 of 2). . . . .	170
Figure 91. Register the glass . . . . .	171
Figure 92. ADF main assembly (1 of 8) . . . . .	172
Figure 93. ADF main assembly (2 of 8) . . . . .	173
Figure 94. ADF optical unit (3 of 8). . . . .	173
Figure 95. ADF main assembly (4 of 8) . . . . .	174
Figure 96. ADF main assembly (5 of 8) . . . . .	174
Figure 97. ADF main assembly (6 of 8) . . . . .	175
Figure 98. ADF main assembly (7 of 8) . . . . .	175
Figure 99. ADF main assembly (8 of 8) . . . . .	176
Figure 100. Remove the ADF optical assembly (1 of 13). . . . .	177
Figure 101. Remove the ADF optical assembly (2 of 13). . . . .	177
Figure 102. Remove the ADF optical assembly (3 of 13). . . . .	178
Figure 103. Remove the ADF optical assembly (4 of 13). . . . .	178
Figure 104. Remove the ADF optical assembly (5 of 13). . . . .	179
Figure 105. Remove the ADF optical assembly (6 of 13). . . . .	179
Figure 106. Remove the ADF optical assembly (7 of 13). . . . .	180
Figure 107. Remove the ADF optical assembly (8 of 13). . . . .	180
Figure 108. Remove the ADF optical assembly (9 of 13). . . . .	181

Figure 109. Remove the ADF optical assembly (10 of 13)	181
Figure 110. Remove the ADF optical assembly (11 of 13)	182
Figure 111. Remove the ADF optical assembly (12 of 13)	182
Figure 112. Remove the ADF optical assembly (13 of 13)	183
Figure 113. ADF scanning lamp (1 of 5)	184
Figure 114. ADF scanning lamp (2 of 5)	184
Figure 115. ADF scanning lamp (3 of 5)	185
Figure 116. ADF scanning lamp (4 of 5)	185
Figure 117. ADF scanning lamp (5 of 5)	186
Figure 118. ADF shading filter (1 of 2)	187
Figure 119. ADF shading filter (2 of 2)	187
Figure 120. Flatbed optical unit (1 of 6)	188
Figure 121. Flatbed optical unit (2 of 6)	188
Figure 122. Flatbed optical unit (3 of 6)	189
Figure 123. Flatbed optical unit (4 of 6)	189
Figure 124. Flatbed optical unit (5 of 6)	190
Figure 125. Flatbed optical unit (6 of 6)	190
Figure 126. Flatbed scanning lamp (1 of 3)	191
Figure 127. Flatbed scanning lamp (2 of 3)	191
Figure 128. Flatbed scanning lamp (3 of 3)	192
Figure 129. ADF feeder cover detection switch	193
Figure 130. Weight solenoid (1 of 2)	194
Figure 131. Weight solenoid (2 of 2)	194
Figure 132. Shutter solenoid	195
Figure 133. Pickup motor (1 of 2)	196
Figure 134. Pickup motor (2 of 2)	196
Figure 135. Delivery motor (1 of 2)	198
Figure 136. Delivery motor (2 of 2)	198
Figure 137. Flatbed motor (1 of 3)	200
Figure 138. Flatbed motor (2 of 3)	200
Figure 139. Flatbed motor (3 of 3)	201
Figure 140. Power supply assembly (1 of 6)	202
Figure 141. Power supply assembly (2 of 6)	202
Figure 142. Power supply assembly (3 of 6)	203
Figure 143. Power supply assembly (4 of 6)	203
Figure 144. Power supply assembly (5 of 6)	204
Figure 145. Power supply assembly (6 of 6)	204
Figure 146. ADF fan	205
Figure 147. Flatbed fan assembly	206
Figure 148. ADF analog processor PCB	207
Figure 149. ADF inverter PCB (1 of 2)	208
Figure 150. ADF inverter PCB (2 of 2)	208
Figure 151. ADF intermediate PCB	209
Figure 152. ADF width detection sensor assembly	210
Figure 153. Flatbed inverter PCB (1 of 2)	211
Figure 154. Flatbed intermediate PCB (1 of 2)	212
Figure 155. Flatbed intermediate PCB (2 of 2)	213
Figure 156. Scanner controller board (1 of 5)	214
Figure 157. Scanner controller board (2 of 5)	214
Figure 158. Scanner controller board (3 of 5)	215
Figure 159. Scanner controller board (4 of 5)	215
Figure 160. Scanner controller board (5 of 5)	216
Figure 161. Intermediate PCB assembly	217
Figure 162. Reinstalling the ADF optic assembly (1 of 2)	217
Figure 163. Reinstalling the ADF optic assembly (2 of 2)	218
Figure 164. Power supply assembly (1 of 6)	219
Figure 165. Power supply assembly (2 of 6)	219
Figure 166. Power supply assembly (3 of 6)	220
Figure 167. Power supply assembly (4 of 6)	220

Figure 168. Power supply assembly (5 of 6) . . . . .	221
Figure 169. Power supply assembly (6 of 6) . . . . .	221
Figure 170. Pickup roller. . . . .	222
Figure 171. Pickup roller assembly . . . . .	223
Figure 172. Feed roller assembly . . . . .	224
Figure 173. Lower registration roller assembly (1 of 10) . . . . .	225
Figure 174. Lower registration roller assembly (2 of 10) . . . . .	226
Figure 175. Lower registration roller assembly (3 of 10) . . . . .	227
Figure 176. Lower registration roller assembly (4 of 10) . . . . .	227
Figure 177. Lower registration roller assembly (5 of 10) . . . . .	228
Figure 178. Lower registration roller assembly (6 of 10) . . . . .	228
Figure 179. Lower registration roller assembly (7 of 10) . . . . .	229
Figure 180. Lower registration roller assembly (8 of 10) . . . . .	229
Figure 181. Lower registration roller assembly (9 of 10) . . . . .	230
Figure 182. Lower registration roller assembly (10 of 10) . . . . .	230
Figure 183. Lower delivery roller (1 of 2) . . . . .	231
Figure 184. Lower delivery roller (2 of 2) . . . . .	231
Figure 185. Upper delivery roller . . . . .	232
Figure 186. Separation belt assembly (1 of 6) . . . . .	233
Figure 187. Separation belt assembly (2 of 6) . . . . .	233
Figure 188. Separation belt assembly (3 of 6) . . . . .	234
Figure 189. Separation belt assembly (4 of 6) . . . . .	234
Figure 190. Separation belt assembly (5 of 6) . . . . .	235
Figure 191. Separation belt assembly (6 of 6) . . . . .	235
Figure 192. Separation belts (1 of 3) . . . . .	236
Figure 193. Separation belts (2 of 3) . . . . .	236
Figure 194. Separation belts (3 of 3) . . . . .	237
Figure 195. Scan engine (HP LJ 9000mfp/9040mfp/9050mfp shown) (1 of 7) . . . . .	238
Figure 196. Scan engine (HP LJ 9000/9040mfp/9050mfp shown) (2 of 7) . . . . .	239
Figure 197. Scan engine (HP LJ 9000/9040mfp/9050mfp shown) (3 of 7) . . . . .	239
Figure 198. Scan engine (HP LJ 9000/9040mfp/9050mfp shown) (4 of 7) . . . . .	240
Figure 199. Scan engine (HP LJ 9000/9040mfp/9050mfp shown) (5 of 7) . . . . .	240
Figure 200. Scan engine (HP LJ 9000/9040mfp/9050mfp shown) (6 of 7) . . . . .	241
Figure 201. Scan engine (HP LJ 9000/9040mfp/9050mfp shown) (7 of 7) . . . . .	241
Figure 202. Sample event log page (HP LJ 9000mfp/9000Lmfp shown) . . . . .	250
Figure 203. Example of events on the event log . . . . .	251
Figure 204. Copy processor board LEDs . . . . .	260
Figure 205. Copy processor LEDs (HP LJ 9040mfp/9050mfp/9500mfp) . . . . .	262
Figure 206. Calibrate the touch screen (HP LaserJet 9000mfp/9000Lmfp) (1 of 3) . . . . .	268
Figure 207. Calibrate the touch screen (HP LaserJet 9000mfp/9000Lmfp) (2 of 3) . . . . .	269
Figure 208. Calibrate the touch screen (HP LaserJet 9000mfp/9000Lmfp) (3 of 3) . . . . .	269
Figure 209. Scanner/ADF test page . . . . .	271
Figure 210. Control-panel up and down arrows . . . . .	272
Figure 211. Left side front calibration (1 of 4) . . . . .	274
Figure 212. Left side front calibration (2 of 4) . . . . .	275
Figure 213. Left side front calibration (3 of 4) . . . . .	275
Figure 214. Left side front calibration (4 of 4) . . . . .	276
Figure 215. ADF motor speed calibration (1 of 2) . . . . .	285
Figure 216. ADF motor speed calibration (1 of 2) . . . . .	285
Figure 217. ADF unit height adjustment (1 of 2) . . . . .	287
Figure 218. ADF unit height adjustment (2 of 2) . . . . .	288
Figure 219. ADF skew adjustment (1 of 3) . . . . .	289
Figure 220. ADF skew adjustment (2 of 3) . . . . .	290
Figure 221. ADF skew adjustment (3 of 3) . . . . .	290
Figure 222. Weight solenoid stroke adjustment . . . . .	292
Figure 223. Sample configuration page (HP LJ 9000mfp/9000Lmfp shown) . . . . .	296
Figure 224. Sample Jetdirect page (HP LJ 9000mfp/9000Lmfp shown) . . . . .	297
Figure 225. Sample supplies status page (HP LJ 9000mfp/9000Lmfp shown) . . . . .	298
Figure 226. Sample usage page (HP LJ 9000mfp/9000Lmfp shown) . . . . .	299

Figure 227. Sample file directory page (HP LJ 9000mfp/9000Lmfp shown) . . . . .	300
Figure 228. Scanner controller PCB (HP LaserJet 9000mfp/9000Lmfp shown) . . . . .	309
Figure 229. Connector locations . . . . .	310
Figure 230. Circuit diagram (1 of 2) . . . . .	312
Figure 231. Circuit diagram (2 of 2) . . . . .	313
Figure 232. MFP system assembly (HP LJ 9000mfp/9000Lmfp/9040mfp/9050mfp shown) . . . . .	328
Figure 233. External panels and covers (1 of 2) . . . . .	329
Figure 234. External panels and covers (2 of 2) . . . . .	330
Figure 235. Flatbed scanner assembly (1 of 3) . . . . .	332
Figure 236. Flatbed scanner assembly (2 of 3) . . . . .	333
Figure 237. Flatbed scanner assembly (3 of 3) . . . . .	334
Figure 238. Flatbed optical assembly . . . . .	337
Figure 239. ADF scanner assembly . . . . .	339
Figure 240. Paper pickup assembly (1 of 2) . . . . .	342
Figure 241. Paper pickup assembly (2 of 2) . . . . .	343
Figure 242. ADF main assembly . . . . .	347
Figure 243. ADF optical assembly . . . . .	350
Figure 244. PCB assemblies . . . . .	352



# 1

# MFP requirements

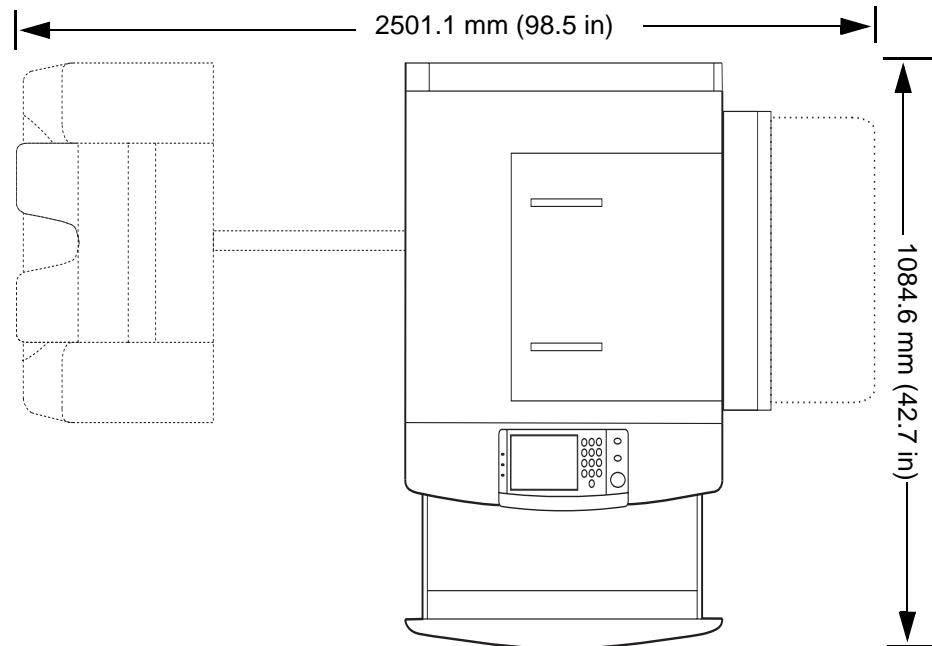
## Chapter contents

Space requirements HP LJ 9000mfp/9000Lmfp/9040mfp/9050mfp . . . . .	18
Space requirements HP LJ 9500mfp . . . . .	20

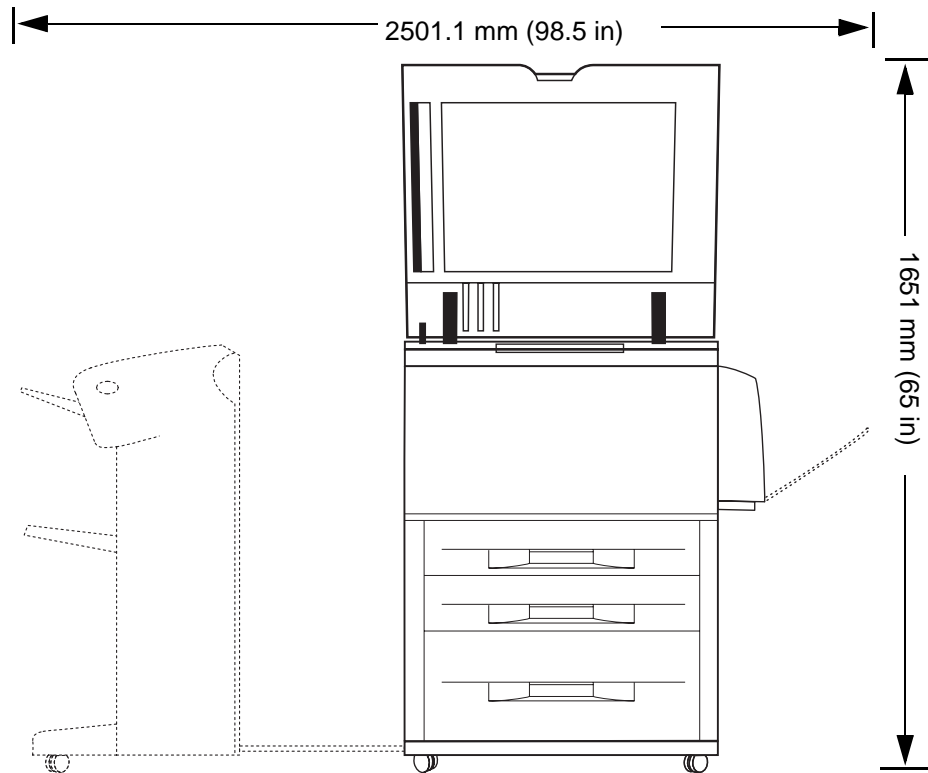
## Space requirements HP LJ 9000mfp/9000Lmfp/9040mfp/9050mfp

The dimensions of the shipping box that contains the HP LaserJet 9000mfp are 1016 mm (40 inches) wide, 914 mm (36 inches) deep, and 1448 mm (57 inches high). The customer must locate a door or receiving area large enough to accept delivery of the shipping box.

### MFP physical dimensions



**Figure 1.** MFP space requirements with a finishing device (HP LJ 9000mfp/9000Lmfp/9040mfp/9050mfp)



**Figure 2. MFP space requirements with a finishing device (HP LJ 9000mfp/9000Lmfp/9040mfp/9050mfp)**

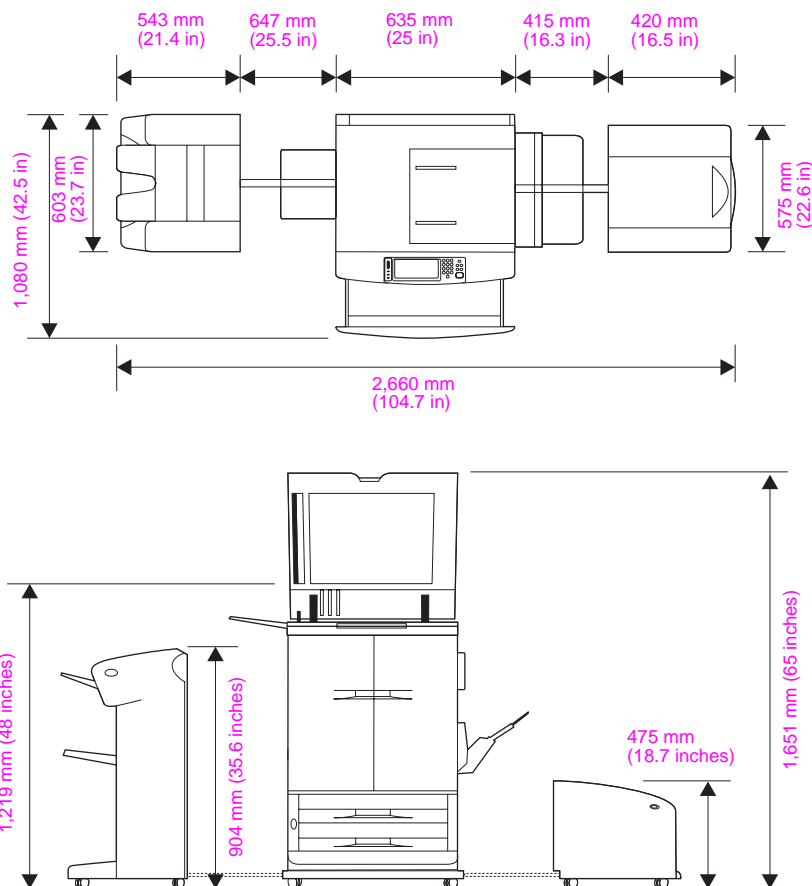
**Note** Before removing the plastic wrapping around the box, make sure that adequate space is available to unpack the MFP and to roll the MFP off of the shipping pallet. At least 10 feet of clearance around the box is required to remove all the shipping materials.

**Note** The front of the shipping box contains a slot that, when opened, reveals the software, the manual, and power cords.

# Space requirements HP LJ 9500mfp

The dimensions of the shipping box that contains the HP LaserJet 9500mfp are 1022 mm (40 inches) wide, 1488 mm (59 inches) deep, and 1200 mm (47 inches) high. The customer must locate a door or receiving area large enough to accept delivery of the shipping box.

## MFP physical dimensions



**Figure 3.** MFP space requirements with a finishing device (HP LJ 9500mfp) (top and front view)

**Note** Before removing the plastic wrapping around the box, make sure that adequate space is available to unpack the MFP and to roll the MFP off of the shipping pallet. At least 10 feet of clearance around the box is required to remove all the shipping materials.

**Note** The front of the shipping box contains a slot that, when opened, reveals the software, the manual, and power cords.

# 2

## MFP information

### Chapter contents

MFP specifications .....	22
Identification .....	22
Specifications .....	23
Interface connections .....	26
Regulatory information .....	28
Service approach .....	28
Parts and supplies .....	28
Warranty .....	28
Limited warranty for the print cartridge .....	28
Service and support .....	29

# MFP specifications

## MFP features

MFP feature information is found in the User Guide for individual models.

## Identification

The model number and serial number are listed on an identification label located on the back cover for the HP LJ 9000mfp/9000Lmfp/9040mfp/9050/mfp and inside of the front door of the HP LJ 9500mfp. The model number is alphanumeric, such as C4270A.

### Note

The serial number alone is on a user-accessible label inside the right door of the print engine that.

The serial number contains information about the country/region of origin and the revision level, production code, and production number of the MFP. An example of a serial number is USBB123456.

The identification label also contains electrical information and regulatory information (see figure 4).

### Note

The electrical information and regulatory information vary by country/region.

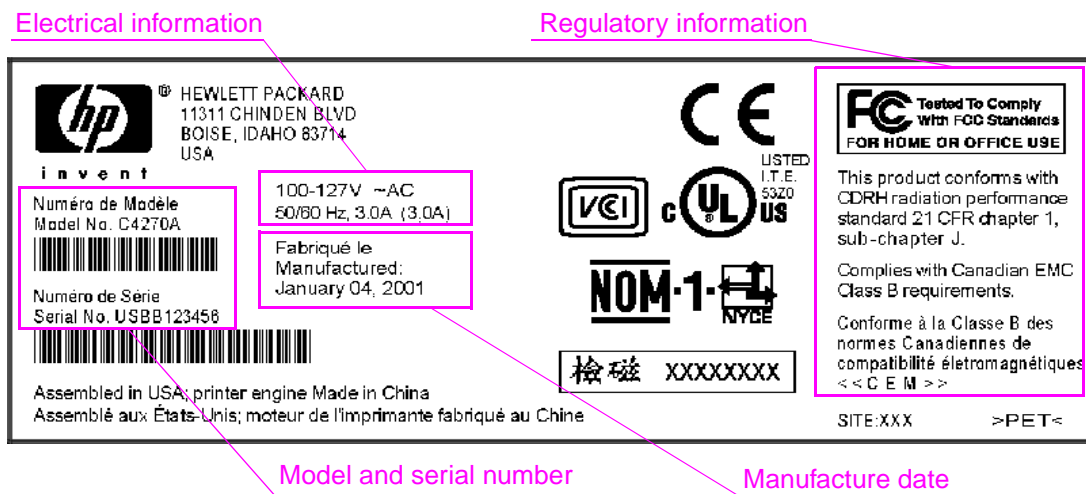


Figure 4. Sample identification label from an HP LaserJet 9000mfp/9000Lmfp

# Specifications

**Table 1. Electrical specifications**

Volts	Frequency	Amperes (amps)	Watts (W) (typical)	Thermal units per hour (Btu/hr)
HP LaserJet 9000mfp/9000Lmfp <sup>1</sup>				
100-127 Vac ± 10 percent	50/60 Hz ± 2 Hz	Minimum recommended current capacity = 15-amp dedicated circuit	printing = 1,075 W standby = 440 W PowerSave 1 = 70 W low power = 230 W off = .5 W ADF printing = 1,130 W	printing = 3,670 Btu/hr standby = 1,500 Btu/hr PowerSave 1 = 240 Btu/hr low power = 785 Btu/hr off = 1.7 Btu/hr ADF printing = 3,860
220-240 Vac ± 10 percent	50/60 Hz ± 2 Hz	Minimum recommended current capacity = 6.5 amp	printing = 1,070 W standby = 415 W PowerSave 1 = 70 W low power = 230 W off = 1.3 W ADF printing = 1,075 W	printing = 3,650 Btu/hr standby = 1,420 Btu/hr PowerSave 1 = 240 Btu/hr low power = 785 Btu/hr off = 4.5 Btu/hr ADF printing = 3,670
HP LaserJet 9040mfp/9050mfp <sup>1</sup>				
100-127 Vac ± 10 percent	50/60 Hz ± 2 Hz	Minimum recommended current capacity = 15-amp dedicated circuit	printing = 1,040 W standby = 265 W PowerSave 1 = 40 W PowerSave 2 = 25 W off = 0 W	printing = 3,550.36 Btu/hr standby = 904.71 Btu/hr PowerSave 1 = 136.56 Btu/hr PowerSave 2 = 85.35 Btu/hr off = 0 Btu/hr
220-240 Vac ± 10 percent	50/60 Hz ± 2 Hz	Minimum recommended current capacity = 6.5-amp dedicated circuit	printing = 995 W standby = 265 W PowerSave 1 = 40 W PowerSave 2 = 25 W off = 0.2 W	printing = 3,396.93 Btu/hr standby = 904.71 Btu/hr PowerSave 1 = 136.56 Btu/hr PowerSave 2 = 85.35 Btu/hr off = 0.69 Btu/hr
HP color LaserJet 9500mfp <sup>1</sup>				
100-127 Vac ± 10 percent	50/60 Hz ± 2 Hz	Minimum recommended current capacity = 15-amp dedicated circuit	printing* = 820 W copying* = 990 W ready = 240 W Sleep 1 = 142 W Sleep 2 = 49 W off = 2 W *24 PPM	printing = 2797.84 Btu/hr copying = 3377.88 Btu/hr ready = 818.88 Btu/hr Sleep 1 = 484.50 Btu/hr Sleep 2 = 167.18 Btu/hr off = 6.82 Btu/hr
220-240 Vac ± 10 percent	50/60 Hz ± 2 Hz	Minimum recommended current capacity = 7 amp	Same as the 110 Vac model.	Same as the 110 Vac model.

<sup>1</sup>Values subject to change. See [www.hp.com.support/lj9000mfp](http://www.hp.com.support/lj9000mfp), [www.hp.com.support/lj9040mfp](http://www.hp.com.support/lj9040mfp), [www.hp.com.support/lj9050mfp](http://www.hp.com.support/lj9050mfp), or [www.hp.com.support/cj9500mfp](http://www.hp.com.support/cj9500mfp) for updated information.

**WARNING!**

Power requirements are based on the region/region where the MFP is sold. Do not convert operating voltages. This can damage the MFP and void the product warranty.

The electrical and environmental specifications must be maintained to ensure the proper operation of the MFP. Consider the following points before installing the MFP:

- Install the MFP in a well-ventilated, dust-free area.
- Install the MFP on a level, flat surface that can support its size and weight. Do not install on carpet or on other soft surfaces. Make sure all four MFP feet are level.
- Make sure the power supply circuitry is adequate. (See “MFP specifications” on page 22.)
- Install the MFP where temperature and humidity are stable, with no abrupt changes (away from water sources, humidifiers, air conditioners, refrigerators, or other major appliances). (See “MFP specifications” on page 22.)
- Install away from direct sunlight, areas that experience vibration, open flames, ammonia fumes, ultrasonic heaters, and devices that emit a magnetic field. If the MFP is placed near a window, make sure the window has a curtain or blind to block direct sunlight.
- Maintain enough space around the MFP for proper access and ventilation. (See “Space requirements HP LJ 9000mfp/9000Lmfp/9040mfp/9050mfp” on page 18, “Space requirements HP LJ 9500mfp” on page 20, or “Space requirements HP LJ 9500mfp” on page 20.)

**Table 2. Environmental specifications HP LJ 9000mfp/9000Lmfp**

	Operating/printing	Storage/standby
Temperature (MFP and print cartridge)	10 degrees to 32.5 degrees C (50 degrees to 90.5 degrees F)	-20 degrees to 40 degrees C (-4 degrees to 104 degrees F)
Relative humidity	20 percent to 80 percent	15 percent to 90 percent

**Table 3. Environmental specifications HP LJ 9040mfp/9050mfp**

	Operating/printing	Storage/standby
Temperature (MFP and print cartridge)	10 degrees to 32 degrees C (50 degrees to 90.5 degrees F)	-20 degrees to 40 degrees C (-4 degrees to 104 degrees F)
Relative humidity	20 percent to 80 percent	15 percent to 90 percent

**Table 4. Environmental specifications HP LJ 9500mfp**

	Operating/printing	Storage/standby
Temperature (MFP and print cartridge)	15 degrees to 30 degrees C (59 degrees to 86 degrees F)	0 degrees to 35 degrees C (32 degrees to 95 degrees F)
Relative humidity	10 percent to 80 percent	10 percent to 95 percent

**Table 5. Noise level specifications HP LJ 9000mfp/9000Lmfp**

	Operator position	Bystander (1m)	Sound power
Copying at 50 ppm	L <sub>Pam</sub> 57 db(A)	L <sub>Pam</sub> 60 db(A)	L <sub>WAd</sub> 7.4 bels(A)
Idle	L <sub>Pam</sub> 40 db(A)	L <sub>Pam</sub> 40 db(A)	L <sub>WAd</sub> 5.7 bels(A)
PowerSave	inaudible	inaudible	inaudible

**Table 6. Noise level specifications HP LJ 9040mfp/9050mfp**

	Operator position	Bystander (1m)	Sound power
Printing at 50 ppm	L <sub>Pam</sub> 59 db(A)	L <sub>Pam</sub> 55 db(A)	L <sub>WAd</sub> 7.1 db(A)
Idle	L <sub>Pam</sub> 43 db(A)	L <sub>Pam</sub> 41 db(A)	L <sub>WAd</sub> 6.0 db(A)
PowerSave	inaudible	inaudible	inaudible

**Table 7. Noise level specifications HP LJ 9500mfp**

	Operator position	Bystander (1m)	Sound power
Printing/copying at 24 ppm	$L_{Wad} = 7.3$ Bells (A) (73 db (A))	$L_{Pam}$ 55 db (A)	NA
Ready	$L_{Wadm} = 5.6$ Bells (A) (56 db (A))	$L_{Pam}$ 37 db (A)	NA
PowerSave	inaudible	inaudible	NA

**Note**

Testing per International Standards Organization (ISO) 9296.

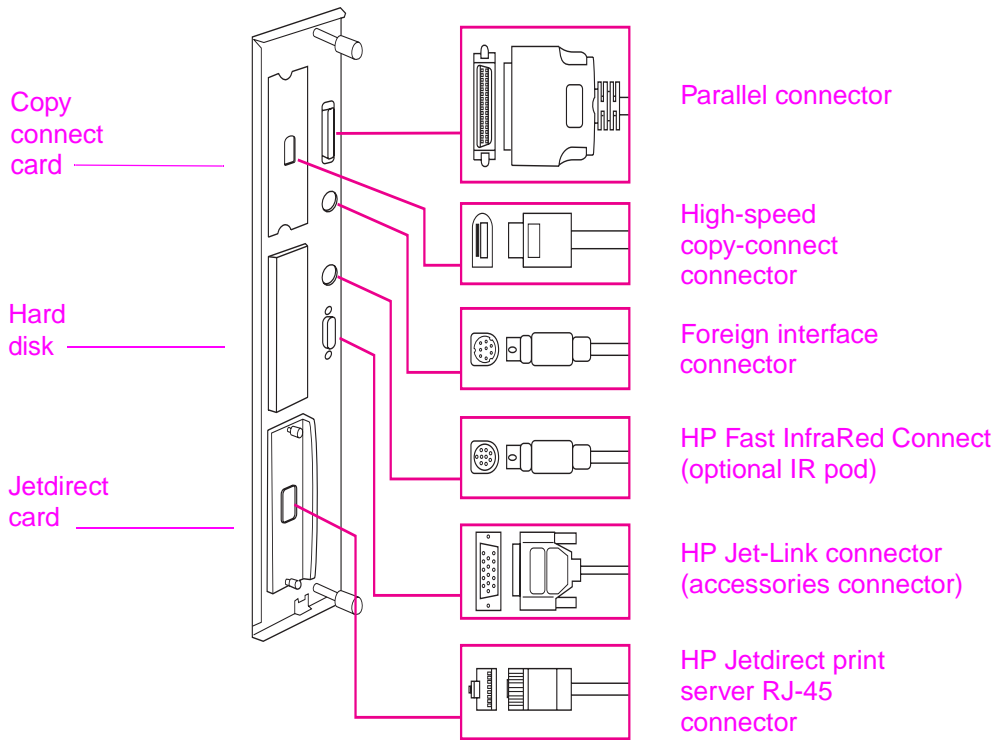
**Table 8. Skew specifications**

	ADF	Platen
Skew	(<= 0.6%)	(<= 0.6%)
Leading edge	+/- 1.5mm	+/- 1.0mm
Left margin	+/- 1.5mm	+/- 1.0mm
Image length and width	+/- 1.0%	+/- 1.0%

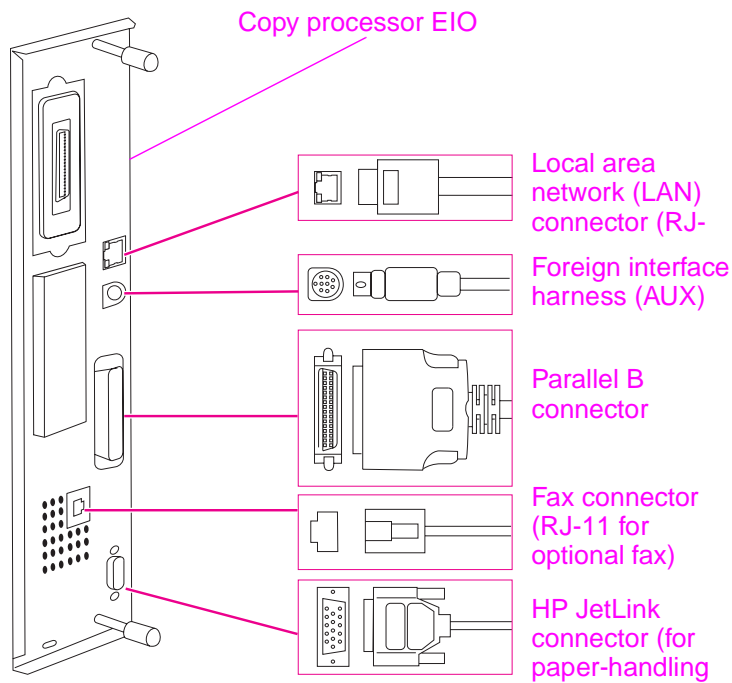
**Note**

For information about skew adjustment, see “ADF skew adjustment” on page 289.

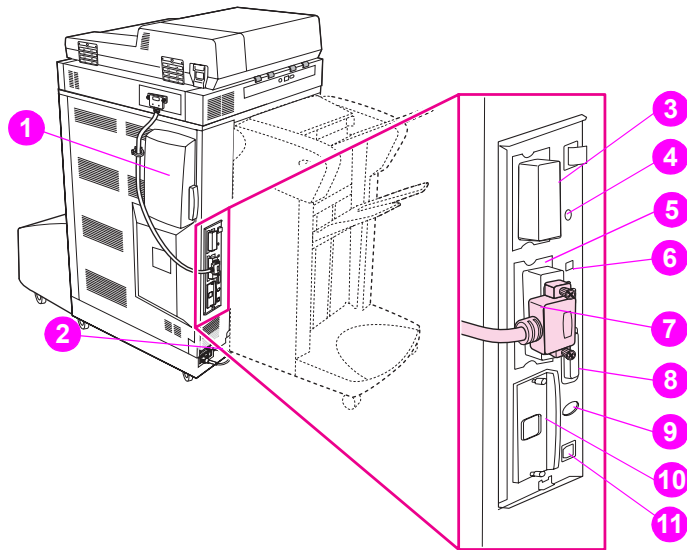
## Interface connections



**Figure 5.** Interface connections HP LJ 9000mfp/9000Lmfp



**Figure 6.** Interface connections HP LJ 9040mfp/9050lmfp



**Figure 7. Interface connections HP LJ 9500mfp**

1	the air filter	5	the RJ11 connector (to the external fax line)	9	the FIH (foreign interface harness) connector
2	the power-cord connector	6	the HP JetLink connector	10	the ethernet network card (EIO)
3	the hard disk (EIO)	7	the copy processor EIO	11	the USB port
4	the disk-drive security lock	8	the parallel port		

## Regulatory information

For regulatory information and requirements, FCC regulations, and declaration of conformity, please see the *start* guide.

For environmental product stewardship program information, please see the *use* guide.

## Service approach

Repair of the MFP normally begins with a three-step process:

- 1 Isolate the problem to the major system (the host computer, the network and/or server, or the MFP).
- 2 Determine whether the problem is located in the print engine, the copy/scan engine, or the finishing device.
- 3 Troubleshoot the problem using “Malfunction troubleshooting” in chapter 7.

Once a faulty part is located, repair is usually accomplished by assembly-level replacement of field replaceable units (FRUs). Some mechanical assemblies can be repaired at the subassembly level. Hewlett-Packard does not support replacement of components on the printed circuit assemblies.

## Parts and supplies

### Information about ordering

Chapter 8 of this manual contains FRU and replacement part numbers. Replacement parts can be ordered from the HP Customer Support (HPCS) organization.

### HPCS phone listings

- HPCS (for U.S.)  
(1) (800) 752-0900
- HPCS (for Canada)  
(1) (800) 387-3867
- HPCS (for Europe)  
(49 7031) 142253

### Exchange program

HP might offer remanufactured assemblies for parts. These can be ordered through HPCS.

## Warranty

For warranty information and requirements, see the *start* guide.

### Limited warranty for the print cartridge

For print cartridge warranty information, see the *start* guide.

# Service and support

## World Wide Web

Print drivers, updated HP MFP firmware, and product and support information can be obtained from the following URLs:

- U.S.
  - [www.hp.com/support/lj9000mfp](http://www.hp.com/support/lj9000mfp)
  - [www.hp.com/support/lj9000Lmfp](http://www.hp.com/support/lj9000Lmfp)
  - [www.hp.com/support/lj9040mfp](http://www.hp.com/support/lj9040mfp)
  - [www.hp.com/support/lj9050mfp](http://www.hp.com/support/lj9050mfp)
  - [www.hp.com/support/clj9500mfp](http://www.hp.com/support/clj9500mfp)
- Europe
  - [www.hp.com/support/lj9000mfp](http://www.hp.com/support/lj9000mfp)
  - [www.hp.com/support/lj9000Lmfp](http://www.hp.com/support/lj9000Lmfp)
  - [www.hp.com/support/lj9040mfp](http://www.hp.com/support/lj9040mfp)
  - [www.hp.com/support/lj9050mfp](http://www.hp.com/support/lj9050mfp)
  - [www.hp.com/support/c/lj9500mfp](http://www.hp.com/support/c/lj9500mfp)
- China
  - <ftp://www.hp.com.cn/support/lj9000mfp>
  - <ftp://www.hp.com.cn/support/lj9000Lmfp>
  - <ftp://www.hp.com.cn/support/lj9040mfp>
  - <ftp://www.hp.com.cn/support/lj9050mfp>
  - <ftp://www.hp.com.cn/support/clj9500mfp>
- Japan
  - <ftp://www.jpn.hp.com/support/lj9000mfp>
  - <ftp://www.jpn.hp.com/support/lj9000Lmfp>
  - <ftp://www.jpn.hp.com/support/lj9040mfp>
  - <ftp://www.jpn.hp.com/support/lj9050mfp>
  - <ftp://www.jpn.hp.com/support/clj9500mfp>
- Korea, [www.hp.co.kr/support/lj9000](http://www.hp.co.kr/support/lj9000)
  - [www.hp.co.kr/support/lj9000mfp](http://www.hp.co.kr/support/lj9000mfp)
  - [www.hp.co.kr/support/lj9000Lmfp](http://www.hp.co.kr/support/lj9000Lmfp)
  - [www.hp.co.kr/support/lj9040mfp](http://www.hp.co.kr/support/lj9040mfp)
  - [www.hp.co.kr/support/lj9050mfp](http://www.hp.co.kr/support/lj9050mfp)
  - [www.hp.co.kr/support/clj9500mfp](http://www.hp.co.kr/support/clj9500mfp)
- Taiwan, the local driver Web site, <http://www.dds.com.tw> or:
  - [www.hp.com.tw/support/lj9000mfp](http://www.hp.com.tw/support/lj9000mfp)
  - [www.hp.com.tw/support/lj9000Lmfp](http://www.hp.com.tw/support/lj9000Lmfp)
  - [www.hp.com.tw/support/lj9040mfp](http://www.hp.com.tw/support/lj9040mfp)
  - [www.hp.com.tw/support/lj9050mfp](http://www.hp.com.tw/support/lj9050mfp)
  - [www.hp.com.tw/support/clj9500mfp](http://www.hp.com.tw/support/clj9500mfp)

## HP-authorized resellers and support

To locate HP-authorized resellers and support, call (1) (800) 243-9816 in the U.S. or (1) (800) 387-3867 in Canada.

## HP service agreements

Call (1) (800) 743-8305 in the U.S. or (1) (800) 268-1221 in Canada.

## HP PartnerCare

You can use the following information to contact HP PartnerCare:

- PartnerShip Web. [www.partner.americas.hp.com](http://www.partner.americas.hp.com)  
e-mail at [websupport@mn1.com](mailto:websupport@mn1.com)
- Connect Online. [www.connect-online.hp.com](http://www.connect-online.hp.com)  
e-mail at PTS, INFOLINE (HP-Germany, exgen1)
- Asia Pacific countries/regions. <http://partnercare.asiapac.hp.com/>
- Canada Partner. [www.canada.hp.com](http://www.canada.hp.com)
- Latin America. [www.conecta.latinamerica.hp.com](http://www.conecta.latinamerica.hp.com)  
e-mail at SUPPORT-TEAM,LAR (HP-Miami, exgen1)

# 3

## MFP configuration

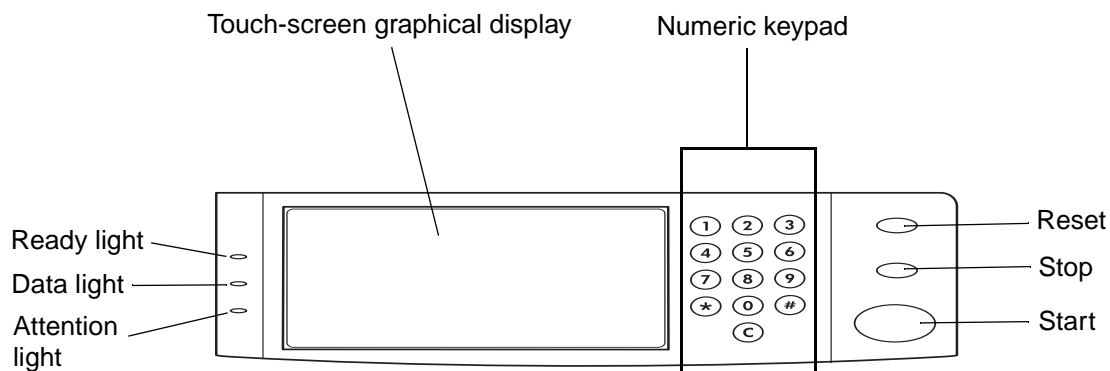
### Chapter contents

Control panel . . . . .	32
Control panel layout HP LJ 9000mfp/9000Lmfp . . . . .	32
Control panel layout HP LJ 9040mfp/9050mfp/9500mfp . . . . .	34
Settings and defaults . . . . .	36
Setting tray registration . . . . .	36
E-mail settings . . . . .	38
FAX settings (HP LaserJet 9040mfp/9050mfp/9500mfp) . . . . .	39
Color copy settings (HP LaserJet 9500mfp) . . . . .	40
Control panel menus (LJ 9000mfp/9000Lmfp/9040mfp/9050mfp) . . . . .	41
Menu map (LJ 9000mfp/9000Lmfp/9040mfp/9050mfp) . . . . .	41
Using a menu map (LJ 9000mfp/9000Lmfp/9040mfp/9050mfp) . . . . .	41
Retrieve job menu (LJ 9000mfp/9000Lmfp/9040mfp/9050mfp) . . . . .	42
Information menu (LJ 9000mfp/9000Lmfp/9040mfp/9050mfp) . . . . .	42
Paper handling menu (LJ 9000mfp/9000Lmfp/9040mfp/9050mfp) . . . . .	43
Configure device menu (LJ 9000mfp/9000Lmfp/9040mfp/9050mfp) . . . . .	45
Diagnostics menu (HP LJ 9000mfp/9000Lmfp/9040mfp/9050mfp) . . . . .	58
Service menu (HP LJ 9000mfp/9000Lmfp/9040mfp/9050mfp) . . . . .	58
Control panel menus (HP CLJ 9500mfp) . . . . .	59
Menu map (CLJ 9500mfp) . . . . .	59
Using a menu map (CLJ 9500mfp) . . . . .	59
Retrieve job menu (CLJ 9500mfp) . . . . .	60
Paper handling menu (CLJ 9500mfp) . . . . .	62
Configure device menu (CLJ 9500mfp) . . . . .	64
Copying submenu (CLJ 9500mfp) . . . . .	65
Enhancement submenu (CLJ 9500mfp) . . . . .	66
E-mail submenu (CLJ 9500mfp) . . . . .	67
EIO submenu (CLJ 9500mfp) . . . . .	78
Printing submenu (CLJ 9500mfp) . . . . .	68
PCL submenu (CLJ 9500mfp) . . . . .	70
Print quality submenu (CLJ 9500mfp) . . . . .	72
System setup submenu (CLJ 9500mfp) . . . . .	74
I/O submenu (CLJ 9500mfp) . . . . .	77
EIO submenu (CLJ 9500mfp) . . . . .	78
Resets submenu (CLJ 9500mfp) . . . . .	81
Diagnostics menu (CLJ 9500mfp) . . . . .	82
Service menu (CLJ 9500mfp) . . . . .	85
Installing firmware updates . . . . .	87
Downloading the new firmware to the MFP . . . . .	87
Troubleshooting a firmware update . . . . .	95

# Control panel

## Control panel layout HP LJ 9000mfp/9000Lmfp

The control panel includes a touch-screen graphical display, three job-control buttons, a numeric keypad, and three light-emitting diode (LED) indicator lights.



**Figure 8.** Control panel layout HP LJ 9000mfp/9000Lmfp

### Control panel features

**Table 9. Control panel features, and key functions**

Feature or key	Function
Touch-screen graphical display	<ul style="list-style-type: none"> <li>Provides access to settings, help screens, copy functions, and shows device status.</li> </ul>
Ready light	<ul style="list-style-type: none"> <li>Off—the MFP is offline or has an error.</li> <li>On—the MFP is ready.</li> <li>Blinking—the MFP is going offline.</li> </ul>
Data light	<ul style="list-style-type: none"> <li>Off—the MFP has no data to print.</li> <li>On—the MFP has data to print but is offline.</li> <li>Blinking—the MFP is processing the data.</li> </ul>
Attention light	<ul style="list-style-type: none"> <li>Off—the MFP has no error.</li> <li>On—the MFP has a critical error; turn power off and then on.</li> <li>Blinking—action is required; see the graphical display.</li> </ul>
RESET	<ul style="list-style-type: none"> <li>Resets the job settings to factory or user-defined default values.</li> </ul>
STOP	<ul style="list-style-type: none"> <li> Cancels the active job.</li> </ul>
START	<ul style="list-style-type: none"> <li> Begins a copy job, starts digital sending, or continues a job that has been interrupted.</li> </ul>
Numeric keypad	<ul style="list-style-type: none"> <li> Allows for input of numeric values.</li> </ul>

## Touch-screen graphical display layout HP LJ 9000mfp/9000Lmfp

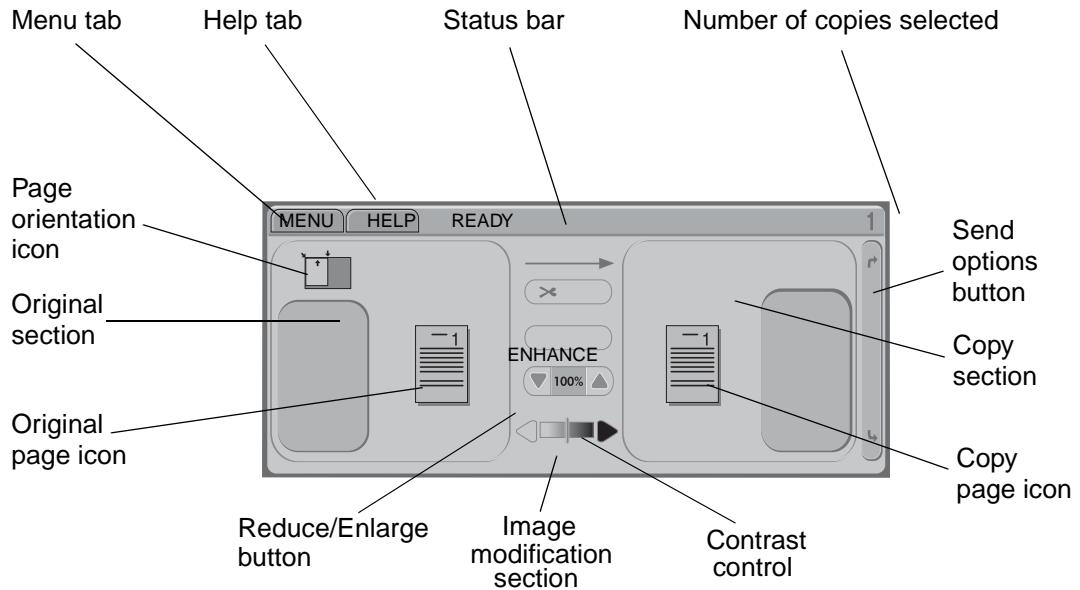





Figure 9.

Touch-screen graphical display layout HP LJ 9000mfp/9000Lmfp

### Touch-screen graphical display features

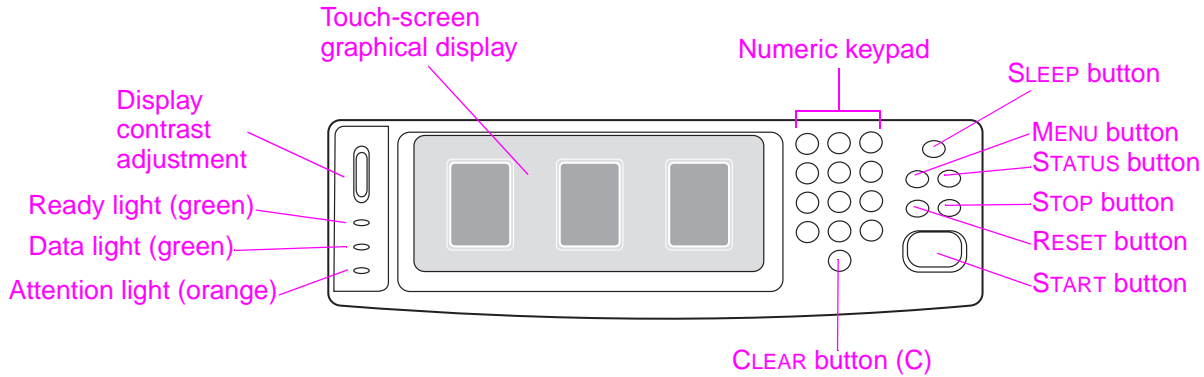
The touch-screen graphical display provides access to settings, help screens, copy functions, and shows device status. User attention messages are shown in a pop-up window with distinct text and codes. See “Troubleshooting with control panel messages” in chapter 7 for error messages associated with the scanner/ADF. For error messages associated with the print engine portion of the MFP, see the *HP LaserJet 9000 and 9050mfp Printer Service Manual*.

Table 10. Touch-screen graphical display features and functions

Feature	Function
Status bar	<ul style="list-style-type: none"> <li>Shows current device status, number of copies, and menu and Help options.</li> </ul>
Menu	<ul style="list-style-type: none"> <li>Provides access to settings, such as paper-handling and device configuration.</li> </ul>
Help	<ul style="list-style-type: none"> <li>Provides access to “What is this?” or “Show me how” Help options.</li> </ul>
Original	<ul style="list-style-type: none"> <li>Shows settings that describe the original document. The MFP automatically detects document size.</li> </ul>
Copy	<ul style="list-style-type: none"> <li>Shows settings that describe the output features of the document.</li> </ul>
Send Options	<ul style="list-style-type: none"> <li>Allows you to send your documents using e-mail.</li> </ul>
Reduce/Enlarge 	<ul style="list-style-type: none"> <li>Reduces or enlarges the size of the scanned image.</li> </ul>
Contrast Control 	<ul style="list-style-type: none"> <li>Increases or decreases the brightness of the scanned image.</li> </ul>
HELP ?	<ul style="list-style-type: none"> <li>Allows access to “What is this?” Help. This feature is embedded in the touch-screen menus.</li> </ul>
Enhance 	<ul style="list-style-type: none"> <li>Allows access to the screen that contains enhancement features.</li> </ul>

## Control panel layout HP LJ 9040mfp/9050mfp/9500mfp

The control panel includes a touch-screen graphical display, three job-control buttons, a numeric keypad, and three light-emitting diode (LED) indicator lights.

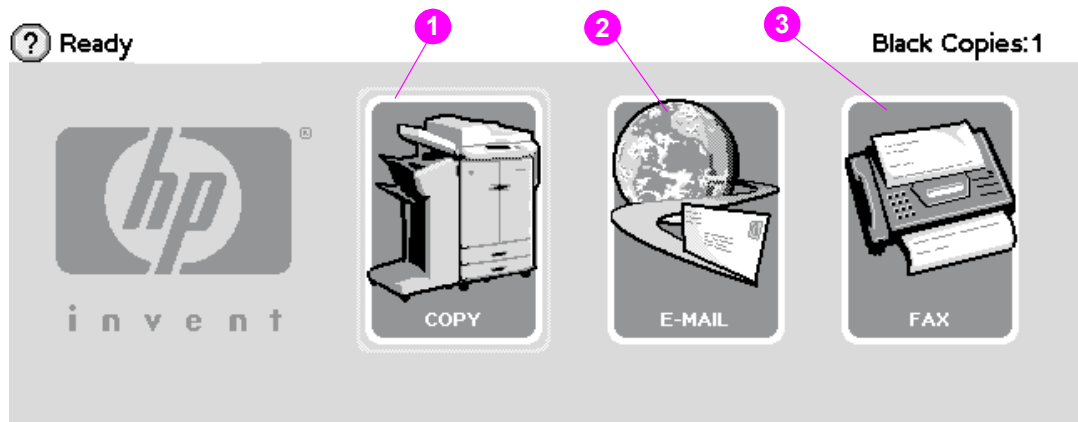


**Figure 10.** Control panel layout HP LJ 9040mfp/9050mfp/9500mfp

### Control panel features

Features and buttons	Function
DISPLAY CONTRAST ADJUSTMENT	Use this to adjust the amount of contrast on the control-panel display.
TOUCH-SCREEN GRAPHICAL DISPLAY	This touch-screen display provides the user with text and graphical information about the configuration and status of the MFP. The touch screen allows you to control all of the MFP functions and features.
SLEEP	Use this to put the MFP in Sleep Mode.
MENU	Use this to open the MFP <b>Information, Configuration</b> , and other menus.
STATUS	This button shows the current jobs and their progress, and also shows the status of the trays and supplies.
RESET	Use this button to reset the job settings to user-defined default values.
STOP	Use this button to cancel the active job.
START	Use this button to begin a copy job, start digital sending or faxing, or continue a job that has been interrupted.
C	This is the <b>Clear</b> button which resets the number of copies to one.
NUMERIC KEYPAD	Use the keypad to type numeric values for the number of copies that are required and to specify other numeric values.

## Touch-screen display layout HP LJ 9040mfp/9050mfp/9500mfp



**Figure 11.** Touch-screen graphical display layout HP LJ 9040mfp/9050mfp/9500mfp

### Touch-screen graphical display features

The home screen, or main menu, displays the three basic functions of the MFP. Touch the corresponding icon to copy, send e-mail, or fax. If additional optional functionality is installed (such as send to network), those icons also appear on the home screen. See “Troubleshooting with control panel messages” in chapter 7 for error messages associated with the scanner/ADF. For error messages associated with the print engine portion of the MFP, see the *HP LaserJet 9500/9500mfp Print Engine Manual*.

**Table 11. Touch-screen graphical display features and functions**

Feature	Function
1	touch this to use the copy screen.
2	touch this to use the e-mail screen.
3	touch this to use the fax screen.
Menu	touch this to open the menus.

# Settings and defaults

Most of the MFP printing decisions are based on temporary settings or on factory defaults.

---

**Note**

---

Most of the settings you send from software applications override MFP defaults.

**Temporary settings** are the values set through your software application for the current print job. Temporary settings remain in effect until the current print job is finished.

**Control panel defaults** are the values entered by selecting a control panel item on the touch screen and then touching it. A bullet (●) next to the item name indicates that it is now the default. The MFP retains default settings even when power is turned off.

**Factory defaults** are preset at the factory and are the default values for each menu item. Factory default values are listed in “Control panel menus (HP CLJ 9500mfp)” on page 59.

## Setting the display language

- 1 Using the control panel, touch **MENU** to open the menus.
- 2 Touch **CONFIGURE DEVICE**, and then press ▼ to scroll to system setup.
- 3 Touch **SYSTEM SETUP**, and then press ▼ to scroll to language.
- 4 Touch **LANGUAGE** to activate the selection screen.
- 5 Select the language you want, and then touch **OK**.

## Setting tray registration

- 1 Using the control panel, touch **MENU** to open the menus.
- 2 Touch **CONFIGURE DEVICE**.
- 3 Touch **PRINT QUALITY**.
- 4 Touch **SET REGISTRATION**.
- 5 Touch **SOURCE**. Select the tray that you want to set registration.
- 6 Touch **PRINT TEST PAGE**.
- 7 The registration page prints. Follow the instructions on the page to complete the registration setting.

---

**Note**

---

The tray registration can only be performed using letter or A4 paper.

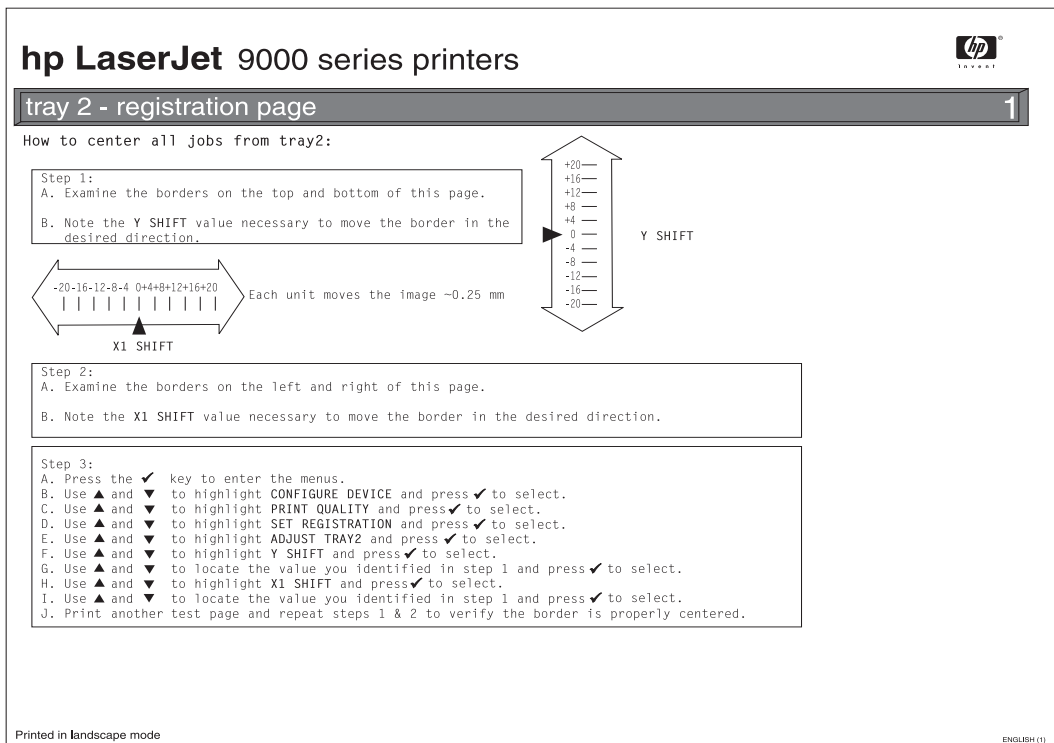


Figure 12. Registration page (HP LJ 9000 Series printer shown) (1 of 2)

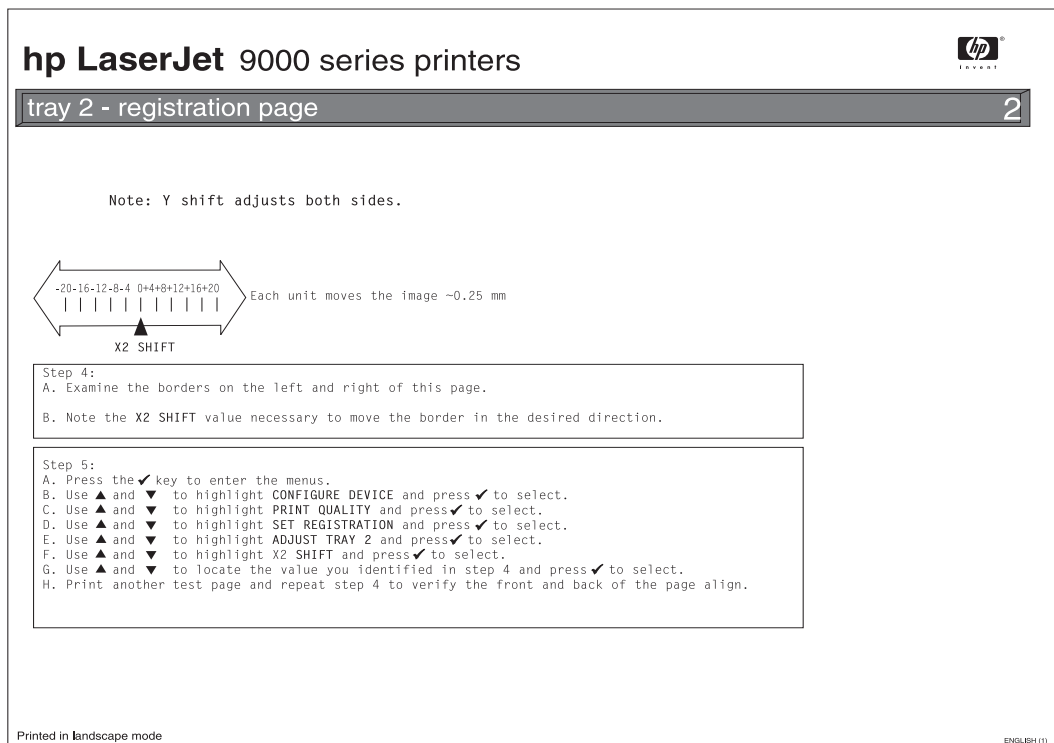


Figure 13. Registration page (HP LJ 9000 Series printer shown) (2 of 2)

## E-mail settings

To configure the embedded Send to e-mail feature, you must either know the Internet Protocol (IP) address or hostname of the Simple Mail Transfer Protocol (SMTP) server on your network, or use the Find Servers menu option to attempt to locate the server. The MFP uses SMTP to send e-mail messages with attachments containing the image that is scanned at the MFP.

Optionally, you can configure the MFP to use the Lightweight Directory Access Protocol (LDAP) to connect to a directory server so that you can easily address an e-mail that will be sent from the MFP. Directory servers contain recipient names (for example, "John Smith"), and associated e-mail addresses (jsmith@hp.com).

When the MFP is configured to use LDAP, users simply type the first few characters of a recipient's name. The MFP searches the directory server for names that match and uses the closest matching name. In most environments, the Embedded Web Server must be used to correctly configure LDAP.

---

### Note

---

If you do not know the IP address or hostname of the SMTP or LDAP servers on your network, ask the network or e-mail administrator for this information.

- 1 Touch **MENU**.
- 2 Touch **CONFIGURE DEVICE**.
- 3 Touch **SENDING**.
- 4 Touch **E-MAIL**.
- 5 You can touch **FIND SEND GATEWAYS** to let the MFP search the local network for LDAP and SMTP servers. If this is successful, go to step 8. Otherwise, go to step 6.
- 6 Touch **SMTP GATEWAY** and then enter the IP address or hostname of the SMTP server. If a LDAP server is available, touch **LDAP GATEWAY** and then enter the IP address or hostname of the LDAP server.
- 7 Touch **OK**.
- 8 Touch **TEST SEND GATEWAYS** to test the configuration.

## FAX settings (HP LaserJet 9040mfp/9050mfp/9500mfp)

After the fax is installed, you must establish these settings before you can use the fax:

- Date and time
- Location (country/region)
- Fax header (phone number and company name)

This information is used in the fax header that is printed on all outgoing faxes.

---

### Note

In the U.S. and many other countries/regions, setting the date, time, location, phone number and company name is a legal requirement.

Because the fax reads some of these settings from the MFP, a value might already be set. Verify the value that appears to make sure that the information is correct.

### Using the Fax Settings menu

Use the **Fax Settings** menu to establish the required fax settings. Press the **MENU** button on the MFP control panel to open the **Fax Settings** menu.

---

### Note

If you have the HP MFP Digital Sending Software installed and the LAN fax is enabled, the fax settings do not appear on the menu because the settings are only used to configure the analog fax. Only one type of fax can be enabled at a time, and only the controls for that fax appear on the control-panel display. If you want to use analog fax when the LAN fax is enabled, use the HP MFP Digital Sending Software Configuration Utility to disable the LAN fax.

### Setting or verifying the date and time

The date and time setting for the fax is the same value as the MFP date and time setting. If you are turning on the MFP for the first time, you will be prompted for this information.

- 1 Press the **MENU** button.
- 2 Scroll to and touch **FAX**.
- 3 Scroll to and touch **FAX SETUP REQUIRED**.
- 4 Scroll to and touch **DATE/TIME**.

Select the date and time formats, and then type the date and time.

### Setting or verifying the location

The location setting identifies the country/region where the MFP is located. This setting selects the date/time format and the minimum and maximum rings-to-answer range for the country/region. Because this setting is a legal requirement in some countries/regions, it must be set before the fax can operate. If you are turning on the MFP for the first time, you will be prompted for this information.

- 1 Press the **MENU** button.
- 2 Scroll to and touch **FAX**.
- 3 Scroll to and touch **FAX SETUP REQUIRED**.
- 4 Scroll to and touch **FAX HEADER**.
- 5 Scroll to and touch **LOCATION**.
- 6 Scroll through the list until your country/region appears, and then touch the country/region to select it.

## Color copy settings (HP LaserJet 9500mfp)

The table in this section describes the HP recommended settings for optimum copy-quality when printing, copying, or scanning using the HP LaserJet 9500mfp. Use the control panel to gain access to the copy screen to change these settings.

**Table 12. Color copy settings (HP LaserJet 9500mfp)**

Describe Original (page content)			
Setting	Best for	What it does	How it affects print quality
Text	Optimized for best black text on a white background.	Increases contrast and sharpens text.	Images will not look as good. Color matching is not as accurate.
Photo	Optimized for best printed half toned images (for example magazines, newspapers, and computer printed graphics).	Optimizes the tone scale for half toned printed images density range.	Text will not be as sharp or dark. Some noise will be present due to the half tone.
Glossy Photo	Optimized for best glossy, continuous-tone glossy photographs.	Optimizes the tone scale for continuous-tone film-based photo density range.	Half tone patterns cause interference. Text will not be as sharp or as dark.
Mixed - Text/Photo Default setting	Optimized for best black text on a white background and half toned image quality.	Contrast is not as high as Text, but higher than Photo. Optimized for a half tone printed photo density range.	Color matching is not as accurate as with photo settings.
Mixed - Text/Glossy Photo	Optimized for best black text on a white background and continuous-tone film-based image quality.	Contrast is not as high as Text, but higher than Photo. Optimized for a glossy film-based photo density range.	Color matching is not as accurate as with photo settings.
Other copy settings			
Setting	Best for	What it does	How it affects print quality
Light/Dark (on the main copy screen)	Enhances by darkening light text on light originals or lighting dark originals.	Tone scale is shifted to lighten or darken output.	Image details might fade in shadowed or highlighted areas.
Background Removal (copy settings - advanced)	Removes bleed through and unwanted background color.	Changes light backgrounds to white.	Light text may fade.
Sharpness (copy settings - advanced)	Increase fine details.	Sharpens images.	Can enhance half tone patterns and make moire patterns more visible.

# Control panel menus (LJ 9000mfp/9000Lmfp/9040mfp/9050mfp)

Touch **MENU** on the touch-screen graphical display to cycle through the control panel menus. Each menu is described in a separate table in this section. Menu items appear only if their associated option is installed, or if their functions are activated. All menus and their associated items are available when the MFP is online.

## Menu map (LJ 9000mfp/9000Lmfp/9040mfp/9050mfp)

From the control panel, you can print a menu map that shows the current MFP configuration. Additional menu items can appear in the control panel, depending on the options currently installed in the MFP. The following is a list of menus available from the control panel, and where to find information about each.

- Retrieve job menu (LJ 9000mfp/9000Lmfp/9040mfp/9050mfp) (page 42)
- Information menu (LJ 9000mfp/9000Lmfp/9040mfp/9050mfp) (page 42)
- Paper handling menu (LJ 9000mfp/9000Lmfp/9040mfp/9050mfp) (page 43)
- Configure device menu (LJ 9000mfp/9000Lmfp/9040mfp/9050mfp) (page 45)
- Resets submenu (LJ 9000mfp/9000Lmfp/9040mfp/9050mfp) (page 57)
- Diagnostics menu (HP LJ 9000mfp/9000Lmfp/9040mfp/9050mfp) (page 58)
- Service menu (HP LJ 9000mfp/9000Lmfp/9040mfp/9050mfp) (page 58)

## Using a menu map (LJ 9000mfp/9000Lmfp/9040mfp/9050mfp)

To see the current settings for the menus and items available in the control panel, select or print a menu map.

### Print a menu map

- 1 Touch **MENU** on the touch screen.
- 2 Touch **INFORMATION MENU**.
- 3 Touch **PRINT MENU MAP**. A current menu map prints.

Values that appear with a bullet (●) next to them are the currently selected values for a setting. Many of these values can be overridden from the print driver or a user program. You might want to store the menu map near the MFP for reference.

The contents of the menu map vary, depending on the optional accessories installed in the MFP. For a complete list of accessories or to change a control panel item and its values, see the following tables.



### Select an item from the menu map

- 1 Touch **MENU** on the touch screen.
- 2 Touch the required menu.
- 3 Touch **▲** or **▼** to scroll to the menu you want, and then touch the required item.

## Retrieve job menu (LJ 9000mfp/9000Lmfp/9040mfp/9050mfp)

### Note

If no private, stored, quick copy, or proof and hold jobs are stored on the printer hard disk or in RAM, the message `NO STORED JOB` appears when the menu is selected.

- 1 A list of user names appears.
- 2 Select a user name, and a list of jobs that are stored for that user appears.
- 3 Select a job name, and print or delete that job. If a job requires a PIN before it can be printed or deleted,  appears next to the `PRINT` or `DELETE` command and a PIN must be typed. If a job requires a PIN to delete,  appears next to the `DELETE` command and a PIN must be provided.

If you select `PRINT`, the printer prompts you to specify the number of copies to print (1 to 32,000).

## Information menu (LJ 9000mfp/9000Lmfp/9040mfp/9050mfp)

Table 13. Information menu (LJ 9000mfp/9000Lmfp/9040mfp/9050mfp)

Item	Explanation
<code>PRINT MENU MAP</code>	Generates a menu map that shows the layout and current settings of the control-menu items. The printer will back up one screen to <code>SET FRONT TO BACK</code> when the page is completed.
<code>PRINT CONFIGURATION</code>	Generates a page detailing the current configuration of the printer. The printer will return to the online <code>READY</code> state when the page is completed.
<code>PRINT SUPPLIES STATUS PAGE</code>	Generates a page that shows the number of pages remaining for each supply in the printer. The printer will return to the online <code>READY</code> state when the page is completed.
<code>PRINT USAGE PAGE</code>	Generates a page that contains information that could be used for cost accounting. This item is only available if a hard disk is installed. The printer will return to the online <code>READY</code> state when the page is completed.
<code>PRINT FILE DIRECTORY</code>	Generates a directory page containing information for all installed mass-storage devices. The printer will return to the online <code>READY</code> state when the page is completed.
<code>PRINT PCL FONT LIST</code>	Generates a typeface list of all PCL fonts that are available on the printer. The printer will return to the online <code>READY</code> state when the page is completed.
<code>PRINT PS FONT LIST</code>	Generates a typeface list of all PS fonts that are available on the printer. The printer will return to the online <code>READY</code> state when the page is completed.

## Paper handling menu (LJ 9000mfp/9000Lmfp/9040mfp/9050mfp)

When paper-handling settings are correctly configured through the control panel, you can print by selecting the type and size of paper from the printer driver or software program.

Some items in this menu (such as duplex and manual feed) are available from specific software programs, or from the printer driver (if the appropriate driver is installed). Printer-driver and software-program settings override control-panel settings.

**Table 14. Information menu (LJ 9000mfp/9000Lmfp/9040mfp/9050mfp)**

Item	Values	Explanation
TRAY 1=FIRST (HP LaserJet 9000mfp/ 9000Lmfp <i>only</i> )	FIRST  CASSETTE	FIRST: The user can specify if media in the tray should be used.  CASSETTE: If set to CASSETTE, the tray must be configured with a size and type, but it then functions like all of the other trays.
TRAY <N> SIZE=LETTER	ANY SIZE LETTER LETTER-ROTATED LEGAL A4 A4-ROTATED EXECUTIVE EXECUTIVE(JIS) A3 A5 B4(JIS) B5(JIS) 8K 16K 8.5 X 13 11 X 17 CUSTOM ANY CUSTOM	The user can set the paper size for trays 2 and 3 and for optional tray 4 (if installed) when the custom switch is in the CUSTOM position. The size is detected if the switch is in the STANDARD position. Substitute the tray number for <N>.
TRAY <N> TYPE=PLAIN	ANY TYPE PLAIN PREPRINTED LETTERHEAD TRANSPARENCY PREPUNCHED LABELS BOND RECYCLED COLOR CARDSTOCK>163 ROUGH 90-105 G/M2 ENVELOPE *	The user can specify the type of media that is loaded in each tray. Substitute the tray number for <N>. *ENVELOPE appears for tray 1 only.

**Table 14. Information menu (LJ 9000mfp/9000Lmfp/9040mfp/9050mfp) (continued)**

Item	Values	Explanation
<p>FUSER MODES (HP LaserJet 9000mfp/ 9000Lmfp <i>only</i>)</p>	<p>List of print-media types</p>	<p>Configure the fuser mode that is associated with each media type. The default value for each paper type is <code>AUTO</code>. The fuser mode can only be changed from this menu option on the control panel.</p> <p><code>AUTO</code>: Utilizes the optimum mode for that media type.</p> <p><code>NORMAL</code>: Normal temperature; prints at 50 pages per minute (ppm).</p> <p><code>LOW</code>: Low temperature; prints at 50 ppm.</p> <p><code>HIGH1</code>: Raises the temperature, prints at 50 ppm.</p> <p><code>HIGH2</code>: Raises the temperature; prints at 32 ppm.</p> <p><code>SPECIAL</code>: Use this mode to print at normal speeds with a 40-second delay added to the beginning of the next job. After each 400 pages are printed, the first page of that job is printed at a slower speed in order to clean the fuser. No defects should be noticeable on the printed page. This is <i>not</i> a preferred setting.</p> <p><b>CAUTION</b></p> <p>If you change the fuser mode to <code>HIGH1</code> or <code>HIGH2</code>, be sure to change it back to the default when you are done printing. Setting a paper type to <code>HIGH1</code> or <code>HIGH2</code> might shorten the life of some consumables, such as the fuser, and might cause other failures or jams.</p>

## Configure device menu (LJ 9000mfp/9000Lmfp/9040mfp/9050mfp)

This menu contains all of the administrative functions.

### Printing submenu (LJ 9000mfp/9000Lmfp/9040mfp/9050mfp)

Some items in this menu are available from a software program, or from the printer driver (if the appropriate driver is installed). Printer-driver and software-program settings override control-panel settings.

**Table 15. Printing submenu (LJ 9000mfp/9000Lmfp/9040mfp/9050mfp)**

Item	Values	Explanation
COPIES=1	1 to 32,000	Set the default number of copies by selecting any number from 1 to 32,000. Use the numeric keypad to select the number of copies.  <b>Note</b> It is best to set the number of copies from the printer driver or software program. (Driver and software settings override control-panel settings.)
DEFAULT PAPER SIZE= LETTER	LETTER LEGAL A4 EXECUTIVE 11X17 A3 B4(JIS) B5(JIS) CUSTOM A5 LETTER ROTATED STATEMENT 8.5X13 12X18 A4 ROTATED RA3 EXECUTIVE(JIS) DPOSTCARDS(JIS) 8K 16k ENVELOPE #10 ENVELOPE MONARCH ENVELOPE C5 ENVELOPE DL ENVELOPE B5	Set the default image size for paper and envelopes. (The item name will change from paper to envelope as you scroll through the available sizes.)
DEFAULT CUSTOM PAPER SIZE	UNIT OF MEASURE X DIMENSION Y DIMENSION	Allows the user to set a custom paper size for any of the installed trays. Substitute the tray number for <N>. This menu only appears when the custom switch in the selected tray is in the custom size position. The user selects the X and Y dimensions of the custom paper size by using the ruler labels in the trays.
PAPER DESTINATION= STANDARD OUTPUT	STANDARD OUTPUT LEFT OUTPUT BIN STANDARD TOP BIN	Allows the user to configure the output bin destination. Only the installed bins appear on the menu.

**Table 15. Printing submenu (LJ 9000mfp/9000Lmfp/9040mfp/9050mfp) (continued)**

Item	Values	Explanation
DUPLEX=OFF	OFF ON	<p>This item appears only when an optional duplex printing accessory is installed. Set the value to <b>ON</b> to print on both sides (duplex) or <b>OFF</b> to print on one side (simplex) of a sheet of paper.</p> <p>For more information, see the HP support flyer or go to <a href="http://www.hp.com/support/lj9000">www.hp.com/support/lj9000</a> or <a href="http://www.hp.com/support/lj9040">www.hp.com/support/lj9040</a> or <a href="http://www.hp.com/support/lj9050">www.hp.com/support/lj9050</a>.</p>
DUPLEX BINDING=LONG EDGE	LONG EDGE SHORT EDGE	<p>Allows the user to change the binding edge for duplex printing. The menu item appears when a duplex printing accessory is installed in the printer and <b>DUPLEX=ON</b>.</p>
OVERRIDE A4/ LETTER=NO	YES NO	<p>This command is used to print on letter-size media when an A4 job is sent, but no A4-size media is loaded in the printer (or to print on A4-size media when a letter job is sent, but no letter media is loaded in the printer).</p>
MANUAL FEED=OFF	OFF ON	<p>Use this item to set the printer to feed the paper manually from optional tray 1, rather than automatically from a tray. When <b>MANUAL FEED=ON</b> and optional tray 1 is empty, the printer goes offline when it receives a print job. The message <b>MANUALLY FEED [PAPER SIZE]</b> appears on the control-panel display.</p>
EDGE TO EDGE OVERRIDE=NO	NO YES	<p>Turn the edge-to-edge mode on or off for all print jobs. This mode can be overridden inside a print job by using an edge-to-edge PJI variable.</p>
COURIER FONT=REGULAR	REGULAR DARK	<p>Select the version of Courier font to use:  <b>REGULAR:</b> The internal Courier font that is available on the HP LaserJet 4 Series printers.  <b>DARK:</b> The internal Courier font that is available on the HP LaserJet III Series printers.            Both fonts are not available at the same time.</p>
WIDE A4=NO	YES NO	<p>The Wide A4 setting changes the number of characters that can be printed on a single line of A4 media.  <b>YES:</b> Up to 80 10-pitch characters can be printed on one line.  <b>NO:</b> Up to 78 10-pitch characters can be printed on one line.</p>
PRINT PS ERRORS=OFF	ON OFF	<p>Select <b>ON</b> to print the PS error page when PS errors occur.</p>
PRINT PDF ERRORS= OFF	OFF ON	<p>Select <b>ON</b> to print the PDF error page when PDF errors occur.</p>

## PCL submenu

Items in the PCL submenu affect PCL tasks.

**Table 16. PCL submenu (LJ9000mfp/9000Lmfp/9040mfp/9050mfp)**

Item	Values	Explanation
FORM LENGTH=60	5 to 128	Sets vertical spacing from 5 to 128 lines for the default paper size. Specify the value by using the numeric keypad.
ORIENTATION= PORTRAIT	PORTRAIT LANDSCAPE	Allows the user to select the default page orientation.  <b>Note</b> It is best to set the page orientation from the printer driver or software program. (Driver and software settings override control-panel settings.)
FONT SOURCE=INTERNAL	INTERNAL CARD SLOT X	<b>INTERNAL:</b> Internal fonts. SLOT 1, 2, or 3: Fonts that are stored in one of the three DIMM slots.
FONT NUMBER=0	0-999	The printer assigns a number to each font and lists the numbers on the PCL Font List. The font number appears in the Font # column of the printout.
FONT PITCH=10.00	0.44 to 99.99	Using the numeric keypad or ▲ and ▼, specify a value. This item might not appear, depending on the font that you selected.
SYMBOL SET=PC-8	Variety of available symbol sets	Select any one of several available symbol sets from the printer control panel. A symbol set is a unique grouping of all of the characters in a font. PC-8 or PC-850 is recommended for line-draw characters.
APPEND CR TO LF=NO	YES NO	Select YES to append a carriage return to each line feed that is encountered in backward-compatible PCL jobs (pure text, no job control). Some environments, such as UNIX®, indicate a new line by using only the line-feed control code. This option allows the user to append the required carriage return to each line feed.
SUPPRESS BLANK PAGES=NO	NO YES	When set to YES, form feeds are ignored if the page is blank.

## Print-quality submenu (LJ 9000mfp/9000Lmfp/9040mfp/9050mfp)

Some items in this menu can be set with a software program, or from the driver (if the appropriate driver is installed). Driver and software settings override control-panel settings.

**Table 17. print-quality submenu (LJ 9000mfp/9000Lmfp/9040mfp/9050mfp)**

Item	Values	Explanation
SET REGISTRATION	PRINT TEST PAGE  SOURCE=TRAY 2  ADJUST TRAY <X>	Shift the margin alignment to center the image on the page from top to bottom, and from left to right. You can also align the image on the front with the image printed on the back.
FUSER MODES (HP LaserJet 9040mfp/ 9050mfp <i>only</i> )	List of media types	<p>Configure the fuser mode that is associated with each print-media type. The fuser mode can only be changed from this menu option on the control panel. The default value for each paper type is <b>AUTO</b>.</p> <p><b>AUTO</b>: Utilizes the optimum mode for that media type.</p> <p><b>NORMAL</b>: Normal temperature; prints at 50 pages per minute (ppm).</p> <p><b>LOW</b>: Low temperature; prints at 50 ppm.</p> <p><b>HIGH1</b>: Raises the temperature; prints at 50 ppm.</p> <p><b>HIGH2</b>: Raises the temperature; prints at 32 ppm.</p> <p><b>SPECIAL</b>: Use this mode to print at normal speeds with a 40-second delay added to the beginning of the next job. After each 400 pages are printed, the first page of that job is printed at a slower speed in order to clean the fuser. No defects should be noticeable on the printed page. This is <i>not</i> a preferred setting.</p> <p><b>CAUTION</b></p> <p>If you change the fuser mode to <b>HIGH1</b> or <b>HIGH2</b>, be sure to change it back to the default when you are done printing. Setting a paper type to <b>HIGH1</b> or <b>HIGH2</b> might shorten the life of some consumables, such as the fuser, and might cause other failures or jams.</p>
RESOLUTION= FASTRES 1200	300 600 FASTRES 1200	<p>Select the resolution from the following values:</p> <p><b>300</b>: Produces draft print quality at maximum printer speed. 300 dpi (dots per inch) is recommended for some bitmapped fonts and graphics, and for compatibility with the HP LaserJet III family of printers.</p> <p><b>600</b>: Produces high print quality at maximum product speed.</p> <p><b>FASTRES 1200</b>: Produces optimum print quality (comparable to 1200 dpi) at maximum product speed.</p> <p><b>Note</b></p> <p>It is best to change the resolution from the driver or software program. (Driver and software settings override control-panel settings.)</p>
RET=MEDIUM	OFF LIGHT MEDIUM DARK	<p>Use the printer Resolution Enhancement technology (REt) setting to produce print that contains smooth angles, curves, and edges. All print resolutions, including FastRes 1200, benefit from REt.</p> <p><b>Note</b></p> <p>It is best to change the REt setting from the driver or software program. (Driver and software settings override control-panel settings.)</p>

**Table 17. print-quality submenu (LJ 9000mfp/9000Lmfp/9040mfp/9050mfp) (continued)**

Item	Values	Explanation
ECONOMODE	ON OFF	When set to “on”, the printer prints by using a reduced amount of toner per page; however, the print quality of the page is drastically reduced.
TONER DENSITY=3	1 to 5	<p>Lighten or darken the print on the page by changing the toner-density setting. The settings range from 1 (light) to 5 (dark), but the default setting of 3 usually produces the best results.</p> <p><b>Note</b> It is best to change the toner density from the driver or software program. (Driver and software settings override control-panel settings.)</p>
SMALL PAPER MODE=NORMAL	NORMAL SLOW	When printing on narrow media, this setting slows down the printer which stabilizes the fuser temperature to minimize wrinkles.
CREATE CLEANING PAGE	No value to select	<p>Press ✓ to print a cleaning page (for cleaning excess toner from the paper path. In order for the cleaning page to work correctly, print the page on copier-grade paper (not bond or rough paper). Follow the instructions on the cleaning page. The progress bar shows the time remaining before the process is complete.</p>
PROCESS CLEANING PAGE	No value to select	<p>This item appears only after a cleaning page has been generated.</p> <p>Press ✓ to process the cleaning page. The progress bar shows the time remaining before the process is complete.</p>

## System setup submenu (LJ 9000mfp/9000Lmfp/9040mfp/9050mfp)

Items in this menu affect the printer function. Configure the printer according to your printing needs.

**Table 18. System setup submenu (LJ 9000mfp/9000Lmfp/9040mfp/9050mfp)**

Item	Values	Explanation
DATE/TIME (HP LaserJet 9040mfp/9050mfp only)	DATE DATE FORMAT TIME TIME FORMAT	Sets the date and time for the printer. The Real Time Clock is set to Greenwich Mean Time (GMT).
JOB STORAGE LIMIT=32	1 to 100	Specifies the number of jobs that can be stored on the printer hard-disk accessory.
JOB HELD TIMEOUT= OFF	OFF 1 HOUR 4 HOURS 1 DAY 1 WEEK	Sets the length of time that quick copy, proof and hold, private, and stored jobs are kept before being automatically deleted from the queue.
SHOW ADDRESS=OFF (HP LaserJet 9040mfp/9050mfp only)	AUTO OFF	Sets whether or not the printer IP address appears with the Ready message. If this value is "on," the address of the EIO card in slot 1 is shown.
TRAY BEHAVIOR (HP LaserJet 9040mfp/9050mfp only)	USE REQUESTED TRAY MANUAL FEED PROMPT PS DEFER MEDIA	Specifies the behavior of the tray by indicating which tray the printer should print from.  USE REQUESTED TRAY sets the tray that the printer should print from for specified jobs. The values for this menu item are EXCLUSIVELY (default) and FIRST.  MANUAL FEED PROMPT determines whether or not the product prompts the user when a job does not match a requested configured tray. The values for this menu item are ALWAYS (default) or UNLESS LOADED.  PS DEFER MEDIA sets whether the paper-handling model is based on PostScript rules or HP rules. The values for this menu item are ENABLED (default) and DISABLED.
SLEEP DELAY=90 MINUTES  POWERSAVE TIME=1 HOUR (HP LaserJet 9000mfp/ 9000Lmfp only)	1 MINUTE 15 MINUTES 30 MINUTES 60 MINUTES 90 MINUTES 2 HOURS 4 HOURS	Set how long the printer remains idle before it enters Sleep mode. The Sleep mode minimizes the amount of power that the printer consumes when it is idle and reduces wear on the printer electronic components.  When you send a print job, press a control-panel button, open a paper tray, or open the top cover, the printer automatically exits Sleep mode.  <b>Note</b> Sleep turns off the backlight on the display, but the display is still readable.
WAKE TIME SUBMENU (HP LaserJet 9040mfp/9050mfp only)	SETTING WAKE TIME	Sets the time that the printer automatically comes out of Sleep mode. This feature can be set for a different time for each day of the week.

**Table 18. System setup submenu (LJ 9000mfp/9000Lmfp/9040mfp/9050mfp) (continued)**

Item	Values	Explanation
PERSONALITY=AUTO	AUTO PCL PS PDF XHTML MIME	Select the default printer language (personality). Possible values are determined by which valid languages are installed in the printer. Normally, you should not change the printer language (the default is AUTO). If you change it to a specific printer language, the printer does not automatically switch from one language to another unless specific software commands are sent to the printer.
CLEARABLE WARNINGS= JOB	ON JOB	Set the amount of time that a clearable warning appears on the printer control panel. ON: Warning messages appear on the control panel until ✓ is pressed. JOB: Warning messages appear on the control panel until the end of the job from which they were generated.
AUTO CONTINUE=ON	ON OFF	Determine how the printer reacts to errors. ON: If an error prevents printing, the message appears, and the printer goes offline for 10 seconds before returning online. OFF: If an error prevents printing, the message remains on the display and the printer does not print until ✓ is pressed.  <b>Note</b> To stop printing when an installed optional stapler accessory is out of staples, set AUTO CONTINUE=OFF on the control-panel <b>System setup</b> menu.
CARTRIDGE LOW= CONTINUE	CONTINUE STOP	Determine how the printer functions when toner is low. The CARTRIDGE LOW message first appears when the print cartridge is almost out of toner. (About 2,400 pages can still be printed at 5% coverage.) CONTINUE: The printer continues to print while the CARTRIDGE LOW message appears. STOP: The printer goes offline and wait for attention.
CARTRIDGE OUT= CONTINUE  (HP LaserJet 9040mfp/9050mfp only)	STOP CONTINUE	Determine how the printer functions when toner is out.
JAM RECOVERY= AUTO	AUTO ON OFF	Determine how the printer functions when a jam occurs. AUTO: The printer automatically selects the best mode for printer jam recovery (usually ON). This is the default setting. ON: The printer automatically reprints pages after a jam is cleared. OFF: The printer does not reprint pages following a jam. Printing performance might be increased with this setting.

**Table 18. System setup submenu (LJ 9000mfp/9000Lmfp/9040mfp/9050mfp) (continued)**

Item	Values	Explanation
RAM DISK=AUTO (HP LaserJet 9000mfp/ 9000Lmfp <i>only</i> )	AUTO OFF	This item determines how the RAM disk is configured. This item appears only if no optional hard disk is installed and the printer has at least 8 MB of memory.  OFF: The RAM disk is disabled.  <b>Note</b> If the setting is changed from OFF to AUTO, the printer automatically reinitializes after it comes out of an idle period.
LANGUAGE=ENGLISH	List of available languages	Sets the language that is used on the control panel.

## I/O submenu (LJ 9000mfp/9000Lmfp/9040mfp/9050mfp)

Items in the *I/O* (input/output) menu affect the communication between the printer and the computer.

**Table 19. I/O timeout submenu (LJ 9000mfp/9000Lmfp/9040mfp/9050mfp)**

Item	Values	Explanation
I/O TIMEOUT=15	5 to 300	Select the <i>I/O</i> timeout period in seconds. ( <i>I/O</i> timeout refers to the time, measured in seconds, that the printer waits before ending a print job.) Use this setting to adjust timeout for best performance. If data from other ports appears in the middle of your print job, increase the timeout value.

**Table 20. Parallel input submenu (LJ 9000mfp/9000Lmfp/9040mfp/9050mfp)**

Item	Values	Explanation
HIGH SPEED=YES	YES NO	The printer accepts the faster parallel communications that are used for connections with newer computers.
ADVANCED FUNCTIONS=ON	ON OFF	Turn the bidirectional parallel communication on or off. The default is set for a bidirectional parallel port (IEEE-1284). This setting allows the printer to send status readback messages to the computer. (Turning the parallel advanced functions on might slow language switching.)

## EIO X Jetdirect submenu (LJ 9000mfp/9000Lmfp/9040mfp/9050mfp)

The EIO (enhanced input/output) submenu appears only when an EIO device is installed in an EIO slot on the printer (such as an HP Jetdirect print server). The items in the menu depend on the particular accessory product that is installed. If the printer contains an HP Jetdirect print server EIO card, you can configure basic networking parameters by using the EIO menu. These and other parameters can also be configured through HP Web Jetadmin or other network configuration tools (such as by using Telnet or browsing the embedded Web server).

For more information about the EIO submenu, see the documentation that came with the EIO Jetdirect card.

**Table 21. EIO X Jetdirect submenu (LJ 9000mfp/9000Lmfp/9040mfp/9050mfp)**

Item	Options	Values	Explanation
TCP/IP	ENABLE	ON	Enable the TCP/IP protocol.
		OFF	Disable the TCP/IP protocol.
	HOST NAME		An alphanumeric string, up to 32 characters, that identifies the device. This name is listed on the Jetdirect configuration page. The default host name is NPIxxxxxx, where xxxxxx is the last six digits of the LAN hardware (MAC) address.
	CONFIG METHOD	BOOTP	Use BootP (Bootstrap Protocol) for automatic configuration from a BootP server.
		DHCP	Use DHCP (Dynamic Host Configuration Protocol) for automatic configuration from a DHCP server. If selected and a DHCP lease exists, DHCP RELEASE and DHCP RENEW menus will be available to set DHCP lease options.
		AUTO IP	Use automatic link-local IP addressing. An address in the form 169.254.x.x will be automatically assigned.
		MANUAL	Use the MANUAL SETTINGS menu to configure TCP/IP parameters.
	DHCP RELEASE		The current DHCP lease along with the leased IP address are released.
DHCP RENEW	NO (default)	The print server does not request to renew the DHCP lease.	
	YES	The print server requests to renew the current DHCP lease.	



**Table 21. EIO X Jetdirect submenu (LJ 9000mfp/9000Lmfp/9040mfp/9050mfp) (continued)**

<b>Item</b>	<b>Options</b>	<b>Values</b>	<b>Explanation</b>
APPLETALK	ENABLE	ON OFF	Enable or disable the AppleTalk protocol.
DLC/LLC	ENABLE		Enable or disable the DLC/LLC protocol.
SECURE WEB	HTTPS REQUIRED  HTTPS OPTIONAL		For secure, encrypted communications, only HTTPS access is accepted. The print server appears as a secure site.  Access is permitted to either HTTP or HTTPS.

**Table 21. EIO X Jetdirect submenu (LJ 9000mfp/9000Lmfp/9040mfp/9050mfp) (continued)**

Item	Options	Values	Explanation	
DIAGNOSTICS HP LJ 9040mfp/ 9050mfp <i>only</i> )	LOOPBACK TEST	YES NO	<b>CAUTION</b> This test will erase your TCP/IP configuration. YES the loopback test will be initiated. NO the loopback test will not be initiated.	
	PING TEST	DEST IP	Specify the IP address of the remote host. A valid IP address must be specified.	
		PACKET SIZE	Specify the size of each packet, in bytes, to be sent to the remote host. The minimum is 64 (default) and the maximum is 2,048.	
		TIMEOUT	Specify the length of time, in seconds, to wait for a response from the remote host. The default is 1 and the maximum is 100.	
		COUNT	Specify the number of ping test packets to send for this test. Select a value from 1 to 100. To configure the test to run continuously, select 0.	
		PRINT RESULTS	If the ping test was not set for continuous operation, you can choose to print the test results. Select YES to print results or NO.	
		EXECUTE	Specify whether to initiate the ping test. Select YES to initiate the test or NO.	
		PING RESULTS	PACKETS SENT	Determines the number of packets (0-65,535) that have been sent to the remote host since the most recent test was initiated or completed.
			PACKETS RECEIVED	Shows the number of packets (0-65,535) that have been received from the remote host since the most recent test was initiated or completed.
			PERCENT LOST	Shows the percent of ping test packets that were sent with no response from the remote host since the most recent test was initiated or completed.
			RTT MIN	Shows the minimum detected round-trip-time (RTT), from 0 to 4096 milliseconds, for packet transmission and response.
			RTT MAX	Shows the maximum detected RTT, from 0 to 4096 milliseconds, for packet transmission and response.
			RTT AVE	Shows the average detected RTT, from 0 to 4,096 milliseconds, for packet transmission and response.
			PING IN PROGRESS	Shows whether or not a ping test is in progress. YES indicates a test in progress and NO indicates that a test completed or was not run.
		REFRESH	Updates the ping test data with current results.	

**Table 21. EIO X Jetdirect submenu (LJ 9000mfp/9000Lmfp/9040mfp/9050mfp) (continued)**

Item	Options	Values	Explanation
RESET SECURITY	NO YES	NO YES	Specifies whether the current security settings on the print server will be saved or reset to factory defaults. NO (default): The current security settings are maintained. YES: The security settings are reset to factory defaults.
LINK SPEED	AUTO  10T HALF  10T FULL  100TX HALF  100TX FULL		The print server automatically configures itself to match the network link speed and communication mode. If it fails, 100TX HALF is set.  10 Mbps, half-duplex operation  10 Mbps, full-duplex operation  100 Mbps, half-duplex operation  100 Mbps, full-duplex operation

## Resets submenu (LJ 9000mfp/9000Lmfp/9040mfp/9050mfp)

### Note

Use this menu with caution. You can lose buffered page data or printer configuration settings when you select these items. Reset the product only under the following circumstances:

- You want to restore the printer default settings.
- Communication between the product and computer has been interrupted.
- You are having problems with a port.

The items in the **Resets** submenu clear all memory in the printer, while **RESET** clears only the current job.

## Diagnostics menu (HP LJ 9000mfp/9000Lmfp/9040mfp/9050mfp)

Use this menu to perform MFP and finishing device diagnostics.

**Table 22. Diagnostics menu (HP LJ 9000mfp/9000Lmfp9040mfp/9050mfp)**

Item	Values	Explanation
DIAGNOSTICS	PRINT EVENT LOG SHOW EVENT LOG PAPER PATH TEST SCANNER TESTS CONTROL PANEL SERVICE TEST	MFP and finishing device diagnostics. A service test can be performed from this menu.

## Service menu (HP LJ 9000mfp/9000Lmfp/9040mfp/9050mfp)

Use this menu to enter the service mode.

- LJ 9000mfp/9000Lmfp PIN: 00900001
- LJ 9040mfp PIN: 11904004
- LJ 9050mfp PIN: 11905004

**Table 23. Service menu (HP LJ 9000mfp/9000Lmfp9040mfp/9050mfp)**

Item	Values	Explanation
SERVICE	CLEAR EVENT LOG TOTAL PAGE COUNT = MAINTENANCE COUNT = MAINTENANCE INTERVAL = 350000 ADF COUNT = FLATBED COUNT = ADF SIMPLEX COUNT = ADF DUPLEX COUNT = COPY SCAN COUNT = SEND SCAN COUNT = COPY PAGES COUNT = SCANNER SETTINGS SERIAL NUMBER = XXXXX COLD RESET PAPER	Use the service menu after service has been performed on the MFP and accessories. Cold-reset paper is set here.

## Control panel menus (HP CLJ 9500mfp)

Touch **MENU** on the touch-screen graphical display to cycle through the control panel menus. Each menu is described in a separate table in this section. Menu items appear only if their associated option is installed, or if their functions are activated.

All menus and their associated items are available when the MFP is online. In menu mode, if no item is touched for approximately 60 seconds, the system automatically returns to the home screen.

### Menu map (CLJ 9500mfp)

From the control panel, you can print a menu map that shows the current MFP configuration. Additional menu items can appear in the control panel, depending on the options currently installed in the MFP. The following is a list of menus available from the control panel, and where to find information about each.

- Retrieve job menu (CLJ 9500mfp) (page 60)
- Information menu (CLJ 9500mfp) (page 61)
- Paper handling menu (CLJ 9500mfp) (page 62)
- Configure device menu (CLJ 9500mfp) (page 64)
- Diagnostics menu (CLJ 9500mfp) (page 82)
- Service menu (CLJ 9500mfp) (page 85)

### Using a menu map (CLJ 9500mfp)

To see the current settings for the menus and items available in the control panel, select or print a menu map.

#### Select an item from the menu map

- 1 Touch **MENU** on the touch screen.
- 2 Touch the required menu.
- 3 Touch **▲** or **▼** to scroll to the page you want, and then touch the required item.

#### Print a menu map

- 1 Touch **MENU** on the touch screen.
- 2 Touch **INFORMATION MENU**.
- 3 Touch **PRINT MENU MAP**. A current menu map prints.


Values that appear with a bullet (●) next to them are the currently selected values for a setting. Many of these values can be overridden from the print driver or a user program. You might want to store the menu map near the MFP for reference.

The contents of the menu map vary, depending on the optional accessories installed in the MFP. For a complete list of accessories or to change a control panel item and its values, see the following tables.


## Retrieve job menu (CLJ 9500mfp)

### Note

If no private, stored, quick copy, or proof and hold jobs are stored on the MFP hard disk or in random-access memory (RAM), the message `NO STORED JOB` appears when the menu is selected.

- 1 A list of user names appears.
- 2 Select a user name, and a list of jobs that are stored for that user appears.
- 3 Select a job name, and print or delete that job. If a job requires a PIN before it can be printed or deleted,  appears next to the `PRINT` or `DELETE` command and a PIN must be typed.
- 4 If you select **PRINT**, the MFP prompts you to specify the number of copies to print (1 to 32,000).

**Table 24. Retrieve job menu (CLJ 9500mfp)**

Item	Explanation
<code>USER 1 (X1)</code> <code>USER 2 (X2)</code> <code>USER 3 (X3)</code> <code>USER 4 (X4)</code> <code>USER 5 (X5)</code> <code>USER 6 (X6)</code>	Use this item to see the private, stored, quick copy, and proof and hold job names for the user name that you select. The <code>(X1)</code> notation is the number of stored print jobs for that user.
<code>&lt;USER NAME&gt;</code> <code>ALL PRIVATE JOBS</code> <code>JOB 1</code> <code>JOB 2</code> <code>JOB 3</code> <code>JOB 4</code>	Use this item to select which print jobs to work with. Select the <code>ALL PRIVATE JOBS</code> option to see a list of all of the print jobs for that user that require a PIN.
<code>&lt;JOB NAME&gt;</code> <code>PRINT</code> <code>DELETE</code>	Use this item to print or delete the selected job.  If a job requires a PIN to be printed or deleted,  appears next to the <code>PRINT</code> or <code>DELETE</code> command, and a PIN must be provided.  If you select <code>PRINT</code> , the printer prompts you to specify the number of copies to print (1 to 32,000).

## Information menu (CLJ 9500mfp)

This menu contains MFP information pages that give details about the MFP and its configuration.

**Table 25. Information menu (CLJ 9500mfp)**

Item	Explanation
PRINT MENU MAP	Use this item to generate a menu map of the layout and the current control-panel menu settings. The MFP backs up one screen to SET FRONT TO BACK when the menu map is completed.
PRINT CONFIGURATION	Use this item to generate a page that indicates the status of all of the consumables. The MFP returns to the READY state when the page is completed.
PRINT SUPPLIES STATUS PAGE	Use this item to generate a page that indicates the number of pages remaining for each supply in the MFP. The MFP returns to the READY state when the page is completed.
PRINT USAGE PAGE	Use this item to generate a page that contains information that can be used for cost accounting. This item is only available if a hard disk is installed. The MFP returns to the READY state when the page is completed.
SUPPLIES STATUS	Use this item to generate a page that indicates availability of the supplies and the status of all of the consumables.
PRINT DEMO	Use this item to generate a demonstration test page that describes the printer features.
PRINT RGB SAMPLES	Use this item to generate a color palette with the associated RGB values.
PRINT CMYK SAMPLES	Use this item to generate a color palette with the associated CMYK values.
PRINT FILE DIRECTORY	Use this item to generate a directory page that contains information for all of the installed mass storage devices. The MFP returns to the READY state when the page is completed.
PRINT PCL FONT LIST	Use this item to generate a typeface list of all of the PCL fonts that are available on the MFP. The MFP returns to the READY state when the page is completed.
PRINT PS FONT LIST	Use this item to generate a typeface list of all of the PS fonts that are available on the MFP. The MFP returns to the READY state when the page is completed.

## Paper handling menu (CLJ 9500mfp)

When paper-handling settings are correctly configured through the control panel, you can print by choosing the type and size of paper from the print driver or software application.

Some items in this menu can be set from a software application or from the print driver (if the appropriate driver is installed). Print-driver and software-application settings override control-panel settings.

### Note

When a value is specified with an ( \* ), that value is the factory (default) setting.

**Table 26. Paper handling menu settings (CLJ 9500mfp)**

Item	Values	Explanation
TRAY <N> SIZE	*ANY SIZE LETTER LETTER ROTATED LEGAL EXECUTIVE STATEMENT 8.5X13 11X17 12X18 A3 A4 A4 ROTATED A5 RA3 B5(ISO) B5(JIS) B4(JIS) EXECUTIVE(JIS) DPOSTCARD(JIS) 8K 16K ENVELOPE #10 ENVELOPE MONARCH ENVELOPE C5 ENVELOPE DL ENVELOPE B5 CUSTOM ANY CUSTOM	Use this item to set the paper size for tray 1, tray 2, tray 3, and the 2,000-sheet side input tray (tray 4). Substitute the tray number for <N>.  <b>Note</b> ENVELOPE #10, ENVELOPE MONARCH, ENVELOPE C5, ENVELOPE DL, STATEMENT, 12X18, RA3, and ENVELOPE B5 appear for tray 1 only.  <b>Note</b> The 2,000-sheet side input tray (tray 4) only supports LETTER, LETTER ROTATED, A4, and A4 ROTATED.

**Table 26. Paper handling menu settings (CLJ 9500mfp) (continued)**

Item	Values	Explanation
TRAY <N> TYPE	*ANY PLAIN PREPRINTED LETTERHEAD TRANSPARENCY PREPUNCHED LABELS BOND RECYCLED COLOR LIGHT<75 G/M2 HEAVY 105-119 G/M2 CARD STOCK>163 GLOSSY 75-105 G/M2 HEAVY GLOSSY NON HP HVY GLOSSY HIGH GLOSS IMAGES TOUGH PAPER ENVELOPE	Use this item to specify the type of media in each tray. Substitute the tray number for <N>.
TRAY <N> CUSTOM	UNIT OF MEASURE X DIMENSION Y DIMENSION	This message appears when the custom switch is in the CUSTOM position and you select CUSTOM from the list of media sizes.  The listed values are available in a pop-up menu where you select millimeters or inches as the unit of measure and set the X and Y dimensions of the custom paper size.

## Configure device menu (CLJ 9500mfp)

This menu contains controls for all of the MFP administrative functions.

### Originals submenu

This submenu controls the default settings for several of the copying functions that relate to the type of originals that are being copied.

---

**Note**

---

When a value is specified with an ( \* ), that value is the factory (default) setting.

**Table 27. Originals submenu (CLJ 9500mfp)**

Item	Values	Explanation
PAPER SIZE	*AUTO LETTER LEDGER LEGAL EXEC A3 A4 A5 B4 B5 BOOK	Use this item to specify the media size of the original document. The MFP uses the media sensors to automatically describe the size of the original document. If media is not detected, you can select from a list of supported media sizes.
NUMBER OF SIDES	*1 2	Use this item to determine whether one side or both sides of the original document are scanned. The MFP prompts you to turn the page over if 2 is selected and the original is placed on the scanner glass.
ORIENTATION	*PORTRAIT LANDSCAPE	Use this item to determine whether the orientation of the original is portrait (short edge top) or landscape (long edge top).
CONTENT	TEXT PHOTO GLOSSY PHOTO MIXED	Use this item to describe the type of image that the original contains. Select text for the best text quality, photo for printed halftone graphics, glossy photo for photographs, or mixed if the original is text and graphics.
DENSITY	0-8 *4	Use this item to describe the density (darkness) of the image that the original contains. 0=darkest 8=lightest
TEXT/PHOTO MIX	0-8	Use this item to determine the priority of text and graphics if CONTENT is defined as mixed. (This item only appears if MIXED is set as the default). You can select from nine increments. 0=emphasis on text 8=emphasis on graphics
HEAVY PAPER	ON *OFF	Use this item to determine whether heavy media is being scanned. If HEAVY PAPER is set to ON, the scanner will adjust the tension on the media as it moves through the scanning area. The setting can impact output quality for media with weights more than 100 g/m <sup>2</sup> (26-lb bond).

## Copying submenu (CLJ 9500mfp)

This submenu controls the default settings for several of the copying functions that relate to the characteristics of the copied output.

### Note

When a value is specified with an ( \* ), that value is the factory (default) setting.

**Table 28. Copying submenu (CLJ 9500mfp)**

Item	Values	Explanation
COLOR MODE	*BLACK COPIES COLOR COPIES	Use this item to specify the walk-up default of black only or color copies.
NUMBER OF SIDES	*1 2	Use this item to specify whether images should be printed on one side or both sides of the copy.
COLLATE	*ON OFF	Use this item to specify whether copies should be collated or not collated.
PAPER DESTINATION	N/A	Use this item to set the default MFP output destination (available values vary depending on the model of output device that is installed).
COPIES	1-999	Use this item to indicate the number of copies that are produced when you press <b>START</b> without selecting the number of copies.  The factory (default) setting is 1.
STAPLE	Values vary depending on the finishing device that is attached	<p>If stapling is requested, use this item to indicate where the staple is placed and how many staples are placed.</p> <p>If a stacker or 8-bin mailbox is attached to the MFP, stapling is not an option.</p> <p>If a stapler/stacker is attached, you can select the following values:</p> <p>*NONE ONE (upper-left corner) CORNER (upper-left corner) TWO THREE SIX CUSTOM (available only if the stapler/stacker has a definition for "custom") OPPOSITE CORNER</p> <hr/> <p><b>Note</b> Because of media size, media orientation, and media feed direction, you should experiment with staple options to find the results you want.</p> <p>If a multifunction finisher is attached, you can select the following values:</p> <p>*NONE ONE TWO SADDLE STITCH</p>

## Enhancement submenu (CLJ 9500mfp)

This submenu controls the default settings for copy enhancement features.

**Table 29. Enhancement submenu (CLJ 9500mfp)**

Item	Values	Explanation
SHARPNESS	0-4	Use this item to specify the sharpness setting. 0=minimum sharpness 4=maximum sharpness  The factory (default) setting is 2.
BACKGROUND REMOVAL	0-8	Use this item to control the amount of background on the original that is eliminated in the copy. Background removal is useful when you copy a two-sided original and do not want the material on the first side to be visible on the second side of the copy or when originals with colored media cause poor copy quality. 0=minimum background removal (more background is visible) 8=maximum background removal (less background is visible)  The factory (default) setting is 2.

## Sending submenu (CLJ 9500mfp)

This submenu contains controls for sending functions.

**Table 30. Sending submenu (CLJ 9500mfp)**

Item	Values	Explanation
E-MAIL	SCANNED PREFERENCE=COLO R	Use this item to set the e-mail defaults. See table 31.
REPLICATE MFP	N/A	This item allows a administrator to duplicate the current digital send configurations of an MFP, and then apply them to another MFP on the same network. Enter the IP address of the target MFP to duplicate MFP configuration.

## E-mail submenu (CLJ 9500mfp)

This submenu contains controls for e-mail settings.

---

**Note**

---

When a value is specified with an ( \* ), that value is the factory (default) setting.

**Table 31. E-mail submenu (CLJ 9500mfp)**

Item	Values	Explanation
SCAN PREFERENCE	BLACK AND WHITE *COLOR	Use this item to specify the walk up default of color or black and white copies (this setting appears on the control-panel display).
FILE TYPE	*PDF MTIFF TIFF JPEG	Use this item to specify the file format of the e-mail attachment.
FILE SIZE	SMALL *STANDARD LARGE	Use this item to specify the compressed value of a document.
RESOLUTION	75 DPI *150 DPI 200 DPI 300 DPI	Use this item to specify the resolution value of a scanned image.
FIND SEND GATEWAYS	No value to select.	Use this item to automatically search the network for SMTP and LDAP gateways that can be used to send e-mail.
SMTP GATEWAY	No value to select.	Use this item to specify the IP address of the SMTP gateway that is used to send e-mail.
LDAP GATEWAY	No value to select.	Use this item to specify the IP address of the LDAP gateway that is used to address e-mail.
TEST SEND GATEWAYS	No value to select.	Use this item to test the configured gateways for correct functionality. If the configured gateways are functional, GATEWAYS OK appears on the control-panel display.

## Printing submenu (CLJ 9500mfp)

Some items in this menu are available from a software program or from the driver (if the appropriate driver is installed). Driver and program settings override control-panel settings.

### Note

When a value is specified with an ( \* ), that value is the factory (default) setting.

**Table 32. Printing submenu (CLJ 9500mfp)**

Item	Values	Explanation
COPIES	1 to 32,000	Use this item to set the default number of copies by specifying any number from 1 to 32,000. Use the numeric keypad to specify the number of copies.  The factory (default) setting is 1.
DEFAULT PAPER SIZE	*LETTER LETTER ROTATED LEGAL EXECUTIVE STATEMENT 8.5X13 11X17 12X18 A3 A4 A4 ROTATED A5 RA3 B5(JIS) B4(JIS) EXECUTIVE(JIS) DPOSTCARD(JIS) 8K 16K ENVELOPE #10 ENVELOPE MONARCH ENVELOPE C5 ENVELOPE DL ENVELOPE B5 CUSTOM	Use this item to set the default size for which media and envelopes to print on if no size is selected for the print job. (The item name changes from media to envelope as you scroll through the available sizes.)  <b>Note</b> This value is used only if no paper size was sent with the job.
DEFAULT CUSTOM PAPER SIZE	UNIT OF MEASURE X DIMENSION Y DIMENSION	Use this item to set a custom media size for any of the installed trays. Substitute the tray number for <N>. This menu only appears when the paper-size switch on the selected tray is in the "custom" position. The user selects the X and Y dimensions of the custom media size using the ruler labels in the trays.

**Table 32. Printing submenu (CLJ 9500mfp) (continued)**

Item	Values	Explanation
PAPER DESTINATION	UPPER BIN LOWER BIN BIN 1 BIN 2 BIN 3 BIN 4 BIN 5 BIN 6 BIN 7 BIN 8 BOOKLET BIN	Use this item to set the output destination. Only the installed bins appear on the menu and the value depends on the finishing device that is installed.
DUPLEX	*OFF ON	<p>This item appears only when a duplexer is installed. Set the value to ON to print on both sides (duplex) or OFF to print on one side (simplex) of a sheet of paper.</p> <hr/> <p><b>Note</b> It is best to set the duplex option in the printer driver or software program. (Printer-driver and software-program settings override control-panel settings.)</p>
DUPLEX BINDING	*LONG EDGE SHORT EDGE	<p>Use this item to change the binding edge for duplex printing. The menu item appears when a duplexer is installed in the printer and DUPLEX=ON.</p> <hr/> <p><b>Note</b> It is best to set the binding layout in the printer driver or software program. (Printer-driver and software-program settings override control-panel settings.)</p>
OVERRIDE A4/ LETTER	*YES NO	<p>Use this item to print on letter-size media when an A4 job is sent but no A4-size media is loaded in the MFP (or to print on A4-size media when a letter job is sent but no letter media is loaded in the MFP).</p> <hr/> <p><b>Note</b> This item also applies to A3- and 11 x 17 size media.</p>
MANUAL FEED	*OFF ON	Feed the media manually from tray 1, rather than automatically from a tray. When MANUAL FEED=ON and tray 1 is empty, the MFP stops and displays MANUALLY FEED [PAPER TYPE SIZE].
COURIER FONT	*REGULAR DARK	Use this item to select the version of Courier font to use: REGULAR: The internal Courier font that is available on the HP LaserJet 4 Series printers. DARK: The internal Courier font that is available on the HP LaserJet III Series printers.
WIDE A4	*NO YES	Use the Wide A4 setting to change the number of characters that can be printed on a single line of A4 media. YES: Up to 80 10-pitch characters can be printed on one line. NO: Up to 78 10-pitch characters can be printed on one line.
PRINT PS ERRORS	*OFF ON	Select ON to print the PS error page when PS errors occur.
PRINT PDF ERRORS	*OFF ON	Select ON to print the PDF error page when PDF errors occur.

## PCL submenu (CLJ 9500mfp)

Use this submenu to specify settings for PCL printing.

---

**Note**

---

When a value is specified with an ( \* ), that value is the factory (default) setting.

**Table 33. PCL submenu (CLJ 9500mfp)**

Item	Values	Explanation
FORM LENGTH	60	Use this item to set vertical spacing from 5 to 128 lines for default media size. Specify the value by using the numeric keypad.
ORIENTATION	*PORTRAIT LANDSCAPE	Use this item to select default page orientation.  <b>Note</b> It is best to set the page orientation from the driver or software program. (Driver and software settings override control-panel settings.)
FONT SOURCE	INTERNAL CARD SLOT 1 CARD SLOT 2 CARD SLOT 3 INTERNAL DISK EIO 1 DISK EIO 2 DISK EIO 3 DISK	INTERNAL: Internal fonts. CARD SLOT X: Fonts that are stored on the compact flash. INTERNAL DISK: Non-removable hard disk (not an EIO). EIO X DISK: Removable hard disk installed in an EIO slot.
FONT NUMBER	0-999	The MFP assigns a number to each font and lists it on the PCL Font List. The font number appears in the Font # column of the printout.  The factory (default) setting is 0.
FONT PITCH	0.44-99.99	Use this item to select a default pitch for a fixed-spaced font.  The factory (default) setting is 10.00.
FONT POINT SIZE	4.00 to 999.75	Use the numeric keypad or scroll and touch to specify a value. This item might not appear, depending on the font that you selected.  The factory (default) setting is 12.00.

**Table 33. PCL submenu (CLJ 9500mfp) (continued)**

Item	Values	Explanation
SYMBOL SET	*PC-8 ROMAN-8 ROMAN-9 ISO L1 ISO L2 ISO L5 ISO L6 ISO L9 PC-775 PC-8 DN PC-850 PC-852 PC-858 PC-8TK PC-1004 WIN L1 WIN L2 WIN L5 WINBALT DESKTOP PS TEXT LEGAL ISO-4 ISO-6 ISO-11 ISO-15 ISO-17 ISO-21 ISO-60 ISO-69 WIN 3.0 MC TEXT UCS-2	<p>Use the numeric keypad or scroll and touch to specify a value. This item might not appear, depending on the font that you selected.</p> <p>Select any one of several available symbol sets from the control panel. A symbol set is a unique grouping of all of the characters in a font. Use of PC-8 or PC-850 is recommended for line-drawing characters.</p>
APPEND CR TO LF	*NO YES	<p>Select YES to append a carriage return to each line feed that is encountered in backward-compatible PCL jobs (pure text, no job control). Some environments, such as UNIX, indicate a new line by using only the line-feed control code. Use this item to append the required carriage return to each line feed.</p>
SUPPRESS BLANK PAGES	*NO YES	<p>Some PCL data streams contain extra form-feed characters. Set this value to YES to ignore form feeds if the page is blank.</p>

## Print quality submenu (CLJ 9500mfp)

Some items in this menu are available from a software program or from the driver (if the appropriate driver is installed). Driver and software program settings override control-panel settings.

**Table 34. Print quality submenu (CLJ 9500mfp)**

Item	Values	Explanation
ADJUST COLOR	HIGHLIGHTS MIDTONES SHADOWS	Use this item to modify density settings for each primary color plane (cyan, magenta, yellow, and black). Each density setting can be modified for the highlights, mid-tones, and shadow regions of the copy. The color density value range is -5 to +5. Negative adjustments lighten the tone curve and positive adjustments darken the tone curve. The factory (default) setting is 0.
SET REGISTRATION	PRINT TEST PAGE SOURCE ADJUST TRAY 1 ADJUST TRAY 2 ADJUST TRAY 3 ADJUST TRAY 4	Shift the margin alignment to center the image on the page from top to bottom, and left to right. You can also align the image on the front with the image that is printed on the back.  Additional instructions are printed on the test page when the source is selected and PRINT TEST PAGE is selected.
PRINT MODES	AUTO SENSE MODE AUTO SENSE OFF LIGHT MODE HEAVY MODE CARDSTOCK MODE TRANSPARENCY MODE ENVELOPE MODE LABEL MODE GLOSSY MODE IMAGE MODE HUY GLOSSY MODE NON HP HUY GLOSSY MODE BEST GLOSSY MODE BEST HP HUY GLOSSY MODE BEST NON HP HUY GLOSSY MODE BEST TOUGH PAPER MODE TONER MODE TOUGH PAPER MODE BLISTERS MODE	Use this item to configure the mode that is associated with the media type that you want to use. For each of the following types, any of the modes listed in the values column can be set.  <b>Note</b> For information about print mode settings, see the <i>HP Color LaserJet 9500/9500mfp Print Engine Service Manual</i> .  PLAIN PREPRINTED LETTERHEAD TRANSPARENCY PREPUNCHED LABELS BOND RECYCLED COLOR LIGHT<75 G/M2 HEAVY 106-163 CARDSTOCK>163 G/M2 GLOSSY 75-105 G/M2 HEAVY GLOSSY NON HP HEAVY HUY GLOSS HIGH GLOSS IMAGE TOUGH PAPER ENVELOPE RESTORE MODES

**Table 34. Print quality submenu (CLJ 9500mfp) (continued)**

Item	Values	Explanation
OPTIMIZE	TRANSFER UP 1 TRANSFER UP 2 TRANSFER DOWN 1 TRANSFER DOWN 2 HIGH COVERAGE 1 HIGH COVERAGE 2 HIGH COVERAGE 3 LEADING EDGE UP LEADING EDGE DOWN RESTORE OPTIMIZE	Use this item to optimize a number of engine parameters for all jobs rather than by media type. Each item can be set to OFF or ON. The default value of each item is OFF. The RESTORE OPTIMIZE option resets all options to the factory default position (OFF).  <b>Note</b> For information about print mode settings, see the <i>HP Color LaserJet 9500/9500mfp Print Engine Service Manual</i> .
QUICK CALIBRATE NOW	No value to select.	Use this item to perform only DMax and DHalf color-tone adjustments.
FULL CALIBRATE NOW	No value to select.	Use this item to perform DMax, DHalf, and color-plane registration (CPR) adjustments.
PROCESS CLEANING PAGE	No value to select.	This item feeds a blank page through the MFP to clean excess toner after a fuser jam.

## System setup submenu (CLJ 9500mfp)

Items in this menu affect the MFP function. Configure the MFP according to your printing needs.

### Note

When a value is specified with an ( \* ), that value is the factory (default) setting.

**Table 35. System setup submenu (CLJ 9500mfp)**

Item	Values	Explanation
DATE/TIME	DATE DATE FORMAT TIME TIME FORMAT	Use this item to set the day, month, year, and time by using the controls on the control-panel display.
JOB STORAGE LIMIT=32	1 to 100	Use this item to specify the number of jobs that can be stored on the hard disk.  The factory (default) setting is 32
JOB HELD TIMEOUT	*OFF 1 HOUR 4 HOURS 1 DAY 1 WEEK	Use this item to set the amount of time that QuickCopy, proof and hold, private, and stored jobs are kept before being automatically deleted from the queue.
SHOW ADDRESS	AUTO *OFF	Use this item to define whether or not the printer IP address appears on the control panel with the READY message. If AUTO is selected, the IP address of the device is shown if the device is connected to a network.
OPTIMUM SPEED/ COST	*AUTO SPEED COST PER PAGE	Use this item to control how the MFP switches from color mode to monochrome mode. AUTO switches between modes based on the job being printed. SPEED increases print speed but is not as efficient when switching modes. COST PER PAGE slows print speed but is the most cost-effective option for switching modes.  <b>Note</b> For information about print mode settings, see the <i>HP Color LaserJet 9500/9500mfp Print Engine Service Manual</i> .
TRAY BEHAVIOR	*USE REQUESTED TRAY MANUALLY FEED PROMPT PS DEFER MEDIA	Use this item to specify the behavior of the trays. Each of the options opens its own submenu:  USE REQUESTED TRAY EXCLUSIVELY. The printer does not automatically select another tray when you indicate that a specific tray should be used. FIRST. The printer pulls media from another tray if the specified tray is empty.  MANUALLY FEED PROMPT ALWAYS. You are always prompted to insert media even if the tray is loaded with media. UNLESS LOADED. You are prompted only if tray 1 is empty.  PS DEFER MEDIA ENABLED. Do <i>not</i> use the PostScript paper-handling function. DISABLED. Use the PostScript paper-handling function.

**Table 35. System setup submenu (CLJ 9500mfp) (continued)**

Item	Values	Explanation
SLEEP DELAY	1 MINUTE 15 MINUTES 30 MINUTES *45 MINUTES 60 MINUTES 90 MINUTES 2 HOURS 4 HOURS	<p>Use this item to set how long the MFP remains idle before it enters Sleep mode. Sleep mode minimizes the amount of power that the MFP consumes when it is idle and reduces wear on the MFP electronic components (turns off the display backlight).</p> <p>When you send a print job, press the control-panel key, open a tray, or open the top cover, the MFP automatically exits Sleep mode.</p> <p><b>Note</b> Sleep mode turns off the backlight on the display, but the display can still be read.</p>
WAKE TIME	OFF* CUSTOM	<p>Use this item to set the day and time that the MFP will automatically exit sleep mode. The custom setting allows you to set the day, hour, and minute (AM or PM) that the MFP will exit sleep mode.</p>
COPY/SEND SETTINGS	INACTIVITY TIMEOUT  AUTO SETTINGS RESET  TIMEOUT AFTER SEND  HOLD OFF PRINT JOB  HOLD OFF TIME  SCAN AHEAD  AUTO JOB INTERRUPT  COPY JOB INTERRUPT  AUDIBLE FEEDBACK	<p><b>INACTIVITY TIMEOUT:</b> The amount of time that the copy, send, or fax settings are kept before resetting to the defined settings. The value range, in seconds, is 10 to 300, and the reset default is 60.</p> <p><b>AUTO SETTINGS RESET:</b> This option resets the copy, send, and fax settings when the <b>START</b> button is pressed. The values are OFF and ON, and the default is OFF.</p> <p><b>TIMEOUT AFTER SEND:</b> The amount of time that a send setting is kept before resetting to the factory (default) settings. The value range is 10 to 300, and the default is 10.</p> <p><b>HOLD OFF PRINT JOB:</b> If this value is set to ON, the print jobs will be held while you are using the MFP control panel.</p> <p><b>HOLD OFF TIME:</b> This value controls how long a print job is held off after the copy/send job is complete.</p> <p><b>SCAN AHEAD:</b> A copy job can be scanned even if the MFP is printing another job. The job is scanned and held until it can be printed. If SCAN AHEAD=OFF, the job will not be scanned until the print job is completed.</p> <p><b>AUTO JOB INTERRUPT:</b> A copy job can automatically interrupt any currently printing network print job in between the number of full copies printed. When this item is set to OFF, the copy job waits until the network print job is completed.</p> <p><b>COPY JOB INTERRUPT:</b> Interrupt the current copy job to make a different copy. When you press the <b>START</b> button, the MFP presents a message that asks if you want to interrupt the current copy job. When set to OFF, the current copy job cannot be interrupted by another copy job.</p> <p><b>AUDIBLE FEEDBACK:</b> Gives an audible indication when a key is pressed or when you touch an interactive area of the touch screen.</p>
PERSONALITY	*AUTO PCL PDF XHTML MIME PS	<p>Use this item to select the default printing language (personality). Possible values are determined by which valid languages are installed in the MFP.</p> <p>Usually, you should not change the MFP language (the default is AUTO). If you change it to a specific MFP language, the MFP does not automatically switch from one language to another unless it receives specific software commands.</p>

**Table 35. System setup submenu (CLJ 9500mfp) (continued)**

Item	Values	Explanation
CLEARABLE WARNINGS	*JOB ON	Use this item to set the amount of time that a clearable warning appears on the control panel. ON: Warning messages appear on the control panel until <b>CONTINUE</b> is touched. JOB: Warning messages appear on the control panel until the end of the job from which they were generated.
AUTO CONTINUE	*ON OFF	Determine how the MFP reacts to errors. ON: If an error prevents printing, the message appears and the MFP goes offline for 10 seconds before returning online. OFF: If an error prevents printing, the message continues to appear and the MFP does not print until <b>CONTINUE</b> is touched.  <b>Note</b> To stop printing when the MFP is out of staples, set <b>AUTO CONTINUE=OFF</b> on the control-panel <b>System setup</b> menu.
SUPPLIES LOW	*CONTINUE STOP	Use this item to determine how the MFP functions when toner is low. The <b>CARTRIDGE LOW</b> message appears when the print cartridge is almost out of toner. (After the message appears, about 2,400 pages can still be printed at 5% coverage.) CONTINUE: The MFP continues to print while the <b>CARTRIDGE LOW</b> message appears. STOP: The MFP goes offline and wait for further action.
COLOR SUPPLY OUT	*STOP AUTOCONTINUE BLACK	If a color supply other than black is not available (empty), the MFP can stop the print job or continue to print using black toner.
JAM RECOVERY	*AUTO OFF ON	Use this item to determine how the MFP functions when a jam occurs. AUTO: The MFP automatically selects the best mode for jam recovery (usually ON). This is the default setting. ON: The MFP automatically reprints pages after a jam is cleared. OFF: The MFP does not reprint pages following a jam. Printing performance might increase with this setting.
LANGUAGE	*ENGLISH CZECH DANISH DUTCH FINNISH FRENCH GERMAN HUNGARIAN ITALIAN NORWEGIAN POLISH PORTUGUESE RUSSIAN SPANISH SWEDISH TURKISH	The available values include all languages in the list, and all supported languages appear. Scroll through the language values until the language that you want appears. Touch the language that you want.

## I/O submenu (CLJ 9500mfp)

Items in the I/O (input/output) menu affect the communication between the MFP and the computer.

---

**Note**

When a value is specified with an ( \* ), that value is the factory (default) setting.

**Table 36. I/O submenu (CLJ 9500mfp)**

Item	Values	Explanation
I/O TIMEOUT	5 to 300	<p>Use this item to select the I/O timeout period in seconds. (The I/O timeout refers to the time, measured in seconds, that the MFP waits before ending a print job.)</p> <p>Use this setting to adjust the timeout for the best performance. If data from other ports appears in the middle of your print job, increase the timeout value.</p> <p>The factory (default) setting is 15.</p>
PARALLEL INPUT SUBMENU	HIGH SPEED ADVANCED FUNCTIONS	<p>Use this item to specify the attributes for a parallel connection.</p> <p><b>HIGH SPEED:</b> Accepts the faster parallel communications that are used for connections with newer computers. The values for HIGH SPEED include YES and NO.</p> <p><b>ADVANCED FUNCTIONS:</b> Turn the bidirectional parallel communication on or off. The default is set for a bidirectional parallel port (IEEE-1284). The values for ADVANCED FUNCTIONS include ON and OFF, and the default is ON.</p> <p>Use this setting to allow the MFP to send status readback messages to the computer. (Turning the parallel advanced functions on might slow the language switching.)</p>

## EIO submenu (CLJ 9500mfp)

The EIO (enhanced input/output) submenu appears only when an EIO device is installed in an EIO slot on the MFP (such as an HP Jetdirect print server). The items in the menu are MFP specific. If the MFP contains an HP Jetdirect print server EIO card, you can configure basic networking parameters by using the **EIO** menu. These and other parameters can also be configured through HP Web Jetadmin or other network configuration tools (such as by using Telnet or browsing with the embedded Web server).

**Table 37. EIO submenu (CLJ 9500mfp)**

Item	Options	Values	Explanation	
TCP/IP	ENABLE	ON OFF	Use this item to specify whether the TCP/IP protocol is enabled (ON) or disabled (OFF).	
	HOST NAME		Use this item to specify an alphanumeric string up to 32 characters. The default host name is NPIXXXXXX, where XXXXXX is the last six digits of the LAN hardware (MAC) address.	
	CONFIG METHOD	BOOTP DHCP AUTO IP MANUAL	Use this item to specify whether the TCP/IP configuration parameters are set automatically from a network server by using BootP (Bootstrap Protocol), DHCP (Dynamic Host Configuration Protocol), Auto IP, or manually from the <b>EIO</b> submenu.	
	DHCP RELEASE	NO YES	This item appears if the Config Method is set to DHCP and a DHCP lease for the print server exists.	
	DHCP RENEW	NO YES	This item appears if Config Method is set to DHCP and a DHCP lease for the print server exists.	
	MANUAL SETTINGS	IP ADDRESS	N.N.N.N	Use this item to provide access to parameters that can be manually configured from the control panel. For manual configuration, CONFIG METHOD must be set to MANUAL. The value represents the unique IP address of the MFP, where N is a value from 0 to 255.
		SUBNET MASK	M.M.M.M	The value represents the subnet mask for the MFP, where M is a value from 0 to 255. The mask is applied to IP addresses to identify subnetworks and modes uniquely.
SYSLOG SERVER		N.N.N.N	The value represents the IP address of the syslog server that is used to receive and log syslog messages.	
	DEFAULT GATEWAY	N.N.N.N	The value represents the IP address of the gateway or router used for communications with other networks.	

**Table 37. EIO submenu (CLJ 9500mfp) (continued)**

Item	Options	Values	Explanation
TCP/IP continued	<p>DEFAULT IP</p> <p>PRIMARY DNS</p> <p>SECONDARY DNS</p> <p>PROXY SERVER</p> <p>PROXY PORT</p>	<p>IDLE TIMEOUT XX</p> <p>AUTO IP LEGACY</p>	<p>The value represents the timeout value (in seconds) after an idle TCP print data connection is automatically closed. The default setting is 270 seconds, and 0 disables the timeout</p> <p>Use this item to specify what you want the IP address to default to when the print server is unable to obtain an IP address from the network during a forced TCP/IP reconfiguration.</p> <p>Use this item to specify the IP address of the primary DNS server.</p> <p>Use this item to specify the IP address of the secondary DNS server.</p> <p>Use this item to specify the proxy server that will be used by embedded software programs.</p> <p>Use this item to enter the port number used by the proxy server for client support. The port number identifies the port reserved for proxy activity on the network. The value can be from 0 to 65,535.</p>
DLC/LLC	ENABLE	ON OFF	Use this item to specify whether the DLC/LLC protocol stack is enabled (ON) or disabled (OFF).
IPX/SPXX	ENABLE	ON OFF	Use this item to specify whether the IPX/SPX protocol stack is enabled (ON) or disabled (OFF).
	FRAME TYPE	AUTO ENL8023 ENLII ENL8022 ENLSNAP	<p>Use this item to specify the frame type setting for your network.</p> <p>AUTO (the default): Automatically sets and limits the frame type to the first one that is detected.</p> <p>For an Ethernet network only, frame-type selections include ENL8023, ENLII, ENL8022, and ENLSNAP.</p>
APPLTALK	ENABLE	ON OFF	Use this item to enable or disable the AppleTalk protocol.
DLC/LLC	ENABLE	ON OFF	Use this item to enable or disable the DLC/LLC protocol.
SECURE WEB		HTTPS REQUIRED HTTPS OPTIONAL	Use this item to specify if the embedded Web server will accept communications by using only HTTPS (secure HTTP) or by using HTTP and HTTPS.
RESET SECURITY		NO YES	Use this item to specify if the current security setting on the print server will be saved or reset to the factory defaults.

**Table 37. EIO submenu (CLJ 9500mfp) (continued)**

Item	Options	Values	Explanation
LINK SPEED		AUTO 10T HALF 10T FULL 100T HALF 100T FULL	Use this item to select the network link speed and communication mode for the print server.

## Resets submenu (CLJ 9500mfp)

### Note

Be careful when using this menu. You can lose buffered page data or MFP configuration settings when you select these items. Reset the MFP with `RESTORE FACTORY SETTINGS` only under the following circumstances:

- You want to restore the MFP default settings.
- Communication between the MFP and the computer is interrupted.
- You are having problems with a port.

The items in the **Resets** submenu clear memory in the MFP, while **RESET** clears only the current job.

**Table 38. Resets submenu (CLJ 9500mfp)**

Item	Explanation
<code>RESTORE FACTORY SETTINGS</code>	Select this item to perform a simple reset and restore most of the factory (default) settings. This item also clears the input buffer for the active I/O. The e-mail gateways are not changed, and the local address book is not cleared. Resetting memory during a print job can result in data loss.
<code>CHARGER CLEANED</code>	Use this item to verify that the post charger was cleaned (only displays if charger cleaning condition has expired).
<code>SLEEP MODE</code>	Use this item to turn <code>SLEEP MODE</code> on and off. If <code>SLEEP MODE</code> is off, the MFP never enters sleep mode and no asterisk appears next to any item when you open the <code>SLEEP DELAY</code> menu item. The values for <code>SLEEP MODE</code> are <code>ON</code> , or <code>OFF</code> , and the default value is <code>ON</code> . When the MFP is in <code>SLEEP MODE</code> , the display backlight is turned off and the message <code>SLEEP ON</code> appears on the control-panel display.
<code>LOCK CARRIAGE</code>	Use this item to move the scan head into the locked position before turning the MFP off and before you transport the MFP.
<code>CLEAR ADDRESS BOOK</code>	Use this item to remove all entries in the local address book.
<code>RESET SUPPLIES</code>	Use this item to indicate that a new supply (consumable) has been installed in the MFP.

## Diagnostics menu (CLJ 9500mfp)

Use this menu to perform MFP and finishing device diagnostics.

**Table 39. Diagnostics menu (CLJ 9500mfp)**

Item	Values	Explanation
PRINT EVENT LOG		Use this item to generate a localized FIFO (first in, first out) list of the 50 most recent entries in the error log. The printed event log shows the error number, page count, error code, and description or personality.
SHOW EVENT LOG		Use this item to scroll through the contents of the event log at the control panel, and to show the 50 most recent events. Use the up arrow and the down arrow to scroll through the event log contents.
PQ TROUBLESHOOTING		Use this item to print eight pages to help you identify print-quality problems. The eight pages consist of two pages of instructions, one page for each color (cyan, magenta, yellow, and black), one demo page, and one configuration page.
DISABLE CARTRIDGE CHECK		Use this item to isolate defective cartridges by removing specific cartridges and then printing internal pages or creating a print job by using the remaining cartridges.
PAPER PATH SENSORS	<p><b>Note</b> A through N appear on the control panel I is omitted).</p> <ul style="list-style-type: none"> <li>● A: Upper cassette feed A</li> <li>● B: Upper cassette feed B</li> <li>● C: Lower cassette feed A</li> <li>● D: Lower cassette feed B</li> <li>● E: Pre-registration</li> <li>● F: Pre-T2</li> <li>● G: Pre-fuser</li> <li>● H: Fuser outlet</li> <li>● J: Duplex reversed</li> <li>● K: Tray 2 Y dimension (cross-feed direction)</li> <li>● M: Media sensor (not OHT = 0, OHT = 3)</li> <li>● N: Media-type-mismatch indication</li> </ul>	<p>This item allows you to monitor the activation of the paper path sensors using the control-panel display, as a sheet is being fed.</p> <p><b>NOTE</b> The STOP button cancels this test. Sensors in tray 4 or the 2,000-side input feeder are not tested with this diagnostic.</p> <p>When the MFP is in this mode, any printed page (internal or from a host PC) can be used for the test.</p>
PAPER PATH TEST	SOURCE DESTINATION DUPLEX COPIES	Use this item to generate a test page that is useful for troubleshooting the MFP paper-handling features. Define the test by selecting one of the options, and then select PRINT TEST PAGE to perform the test.

**Table 39. Diagnostics menu (CLJ 9500mfp) (continued)**

Item	Values	Explanation
MANUAL SENSOR TEST	A TO U 0 OR 1  <ul style="list-style-type: none"> <li>● A: Pre-registration</li> <li>● B: T2</li> <li>● C: Paper path</li> <li>● D: Fuser outlet</li> <li>● E: Face-down outlet</li> <li>● F: Face-down capacity full</li> <li>● G: Tray 1 media presence</li> <li>● H: Tray 2 media presence</li> <li>● J: Tray 2 feed sensor A and B</li> <li>● K: Tray 2 X dimension (cross feed direction)</li> <li>● L: Tray 2 Y dimension (cross feed direction)</li> <li>● M: Tray 3 media presence</li> <li>● N: Tray 3 feed sensor A and B</li> <li>● P: Tray 3 X dimension (cross feed direction)</li> <li>● Q: Tray 3 Y dimension (feed direction)</li> <li>● R: Lower right door</li> <li>● S: Right front/upper right door interlock</li> <li>● T: Left front/lower left door interlock</li> <li>● U: Upper left door</li> </ul>	Use this item to manually test paper-path sensors and switches. The sensor test reviews five areas: Paper path, trays, doors, environment, and toner density.
COMPONENT TEST	TRANSFER MOTORS BELT ONLY DEVELOPER MOTORS CARTRIDGE MOTORS YELLOW LASER SCANNER MAGENTA LASER SCANNER CYAN LASER SCANNER BLACK LASER SCANNER FUSER MOTOR TRAY PICKUP PREREGISTRATION REGISTRATION FACE UP SOLENOID	Use this test to exercise individual parts independently to isolate noise, leaks, or other issues. The results of the test depend on your observation of the printer during the test to determine the source of the problem.  When you select one of the components for testing, the printer goes offline and runs the test based on the REPEAT value. Depending on the component that you select, you might be prompted to remove parts from the printer. If you do not remove the correct parts or if you press the <b>STOP</b> button, the display returns to the <b>Diagnostics</b> menu. When the test is complete, the control panel also returns to the <b>Diagnostics</b> menu.
PRINT/STOP TEST	STOP TIME=0 MILLISECONDS	Use this item to isolate faults by stopping the printer in the middle of a print cycle to observe at what point in the process the image degrades. The range is 0 to 60,000 milliseconds, using increments of 10.

**Table 39. Diagnostics menu (CLJ 9500mfp) (continued)**

Item	Values	Explanation
COLOR BAND TEST	PRINT TEST PAGE COPIES	<p>Use this item to identify arcing in the high-voltage power supplies. The test includes printing a bar pattern that contains specific colors. The Color Band Test page should be printed on 11 x 17 or A3 paper, if available. If not, letter or A4 paper should be used.</p> <p>Evidence of arcing might not appear until a series of pages has been printed. Use the COPIES option to control how many copies of the internal page to print. The range is 1 to 30.</p>
SCANNER TESTS	LOWER LAMP UPPER LAMP SHUTTER SOLENOID WEIGHT SOLENOID SENSORS ADF OUTPUT MOTOR ADF INPUT MOTOR ADF INPUT REVERSE FLATBED MOTOR	Use this item to exercise the named components on the scanner and ADF area of the MFP.
CONTROL PANEL	LEDS DISPLAY BUTTONS TOUCH SCREEN	Use this item to exercise the functionality of the main components of the MFP control panel.

## Service menu (CLJ 9500mfp)

Use this menu to enter the service mode. A personal identification number is needed to open the service menu (the PIN for the HP CLJ 9500mfp is 11950004).

**Table 40. Service menu (CLJ 9500mfp)**

Item	Setting	Submenu 1	Submenu 2	Explanation
SERVICE	CLEAR EVENT LOG			Clear the event log after maintenance or repairs are accomplished.
	TOTAL MONO PAGES			View, or set the total monochrome page count if the count is lost.
	TOTAL COLOR PAGES			View, or set the total color page count if the count is lost.
	REFURBISH PAGE COUNT			View, or set the total refurbished page count if the count is lost.
	CLEANING KIT COUNT			View, or set the total cleaning page count if the count is lost.
	TRANSFER KIT COUNT			View, or set the total transfer kit page count if the count is lost.
	FUSER KIT COUNT			View, or set the total fuser kit page count if the count is lost.
	ADF COUNT			View, or set the total ADF page count if the count is lost.
	FLATBED COUNT			View, or set the total flatbed page count if the count is lost.
	ADF SIMPLEX COUNT			View, or set the total ADF simplex page count if the count is lost.
	ADF DUPLEX COUNT			View, or set the total ADF duplex page count if the count is lost.
	COPY SCAN COUNT			View, or set the total copy scan page count if the count is lost.
	SEND SCAN COUNT			View, or set the total send scan page count if the count is lost.
COPY PAGES COUNT			View, or set the total copy pages page count if the count is lost.	

**Table 40. Service menu (CLJ 9500mfp) (continued)**

Item	Setting	Submenu 1	Submenu 2	Explanation
SERVICE cont.	SCANNER SETTINGS			Scanner settings are used to calibrate the scanner. See "Scanner/ADF calibration simplified" on page 271.
		ADF SETTINGS	LEADING EDGE BACK LEFT SIDE FRONT LEFT SIDE BACK ADF PLAIN SCALING ADF HEAVY SCALING MOTOR SPEED PLAIN MOTOR SPEED HEAVY	Use these settings to correctly position images copied by using the ADF. See "Scanner/ADF calibration simplified" on page 271.
		GLASS SETTINGS	LEFT SIDE GLASS GLASS SCALING	Use these settings to correctly position images copied by using the glass. See "Scanner/ADF calibration simplified" on page 271.
		CLOCK/DENSITY SETUP <b>WARNING!</b> Do not change these settings unless the factory set values are lost. Re-enter the factory values from the label behind the control panel. See "Scanner controller PCB" on page 309. Incorrect settings <i>will</i> cause severe scanner errors or image-quality problems.	XP1 CLOCK SETUP 2 XP2 CLOCK SETUP 1 XP2 CLOCK SETUP 2 XCP CLOCK SETUP 1 XCP CLOCK SETUP 2 XRS CLOCK SETUP 1 XRS CLOCK SETUP 2	<i>Only</i> use these settings if you must manually enter the factory values from the scanner controller board label. See "Scanner controller PCB" on page 309.
			DENSITY SETUP 1 DENSITY SETUP 2	<i>Only</i> use these settings if you must manually re-enter the factory values from the scanner controller board label (because the values were lost). See "Scanner controller PCB" on page 309. This option adjusts the level of signal that is sent from the CCD to the analog boards. Incorrect settings <i>will</i> cause scanner errors or severe image-quality problems. Density 1 is the signal GAIN. Density 2 is the signal OFFSET. See "Scanner controller PCB" on page 309.
		SCB FLASH UPGRADE		<i>Only</i> use this option if there is a 30.01.12 or 30.01.13 communication error after replacing the ADF or flatbed optical assemblies (LJ9000mfp/9000Lmfp/9040mfp/9050mfp/9500mfp) or the ADF analog board (LJ 9000mfp/9000Lmfp). This option causes the scanner controller board and the analog boards on the ADF and flatbed optical assemblies to start communicating (if they were replaced).
		ADF TRAY WIDTH		If the ADF tray width sensor is replaced, use this option to calibrate the tray guides variable-resistor. Follow the instructions on the control-panel display after selecting the ADF TRAY WIDTH option.
		SAVE SETTINGS		Saves calibration settings when the scanner controller board is replaced.
		RESTORE SETTINGS		Restores calibration settings when the scanner controller board is replaced.
		SERIAL NUMBER		View, or set the serial number if the number is lost.
	SERVICE ID		Establishes the first power-on date for warranty determination.	
	COLD RESET PAPER		Set letter or A4 for the MFPs as the default paper size.	

# Installing firmware updates

---

**Note**

---

Example firmware update file names in this section are the update firmware file for the HP color LaserJet 9500mfp. You must substitute the correct file name for the update firmware file for the your specific model.

The MFP can use newer versions of its firmware as they become available. To obtain the latest firmware, go to one of the Web sites listed below, and follow the instructions on the screen. To download firmware updates easily to one or to many printers and MFPs, use the HP Web Jetadmin software (go to [www.hp.com/go/webjetadmin](http://www.hp.com/go/webjetadmin)).

- [www.hp.com/go/lj9000mfp](http://www.hp.com/go/lj9000mfp)
- [www.hp.com/go/lj9000Lmfp](http://www.hp.com/go/lj9000Lmfp)
- [www.hp.com/go/lj9040mfp](http://www.hp.com/go/lj9040mfp)
- [www.hp.com/go/lj9050mfp](http://www.hp.com/go/lj9050mfp)
- [www.hp.com/go/clj9500mfp](http://www.hp.com/go/clj9500mfp)

## Downloading the new firmware to the MFP

The MFP can receive an .RFU file update when the MFP is in the **READY** state. The MFP waits for all of the I/O channels to become idle before performing the update.

---

**Note**

---

The firmware update involves a change in the format of nonvolatile random-access memory (NVRAM). Any menu settings that are changed from the default settings return to default settings and must be changed again if you want settings that are different from the defaults. Examples of settings that are affected in this way are tray types, default symbol sets, and Web access alerts.

The elapsed time for an update depends on the I/O transfer time, as well as the time that it takes for the MFP to reinitialize. The I/O transfer time depends on a number of things, including the speed of the host computer that is sending the update and the I/O method (Fast InfraRed Connect [FIR], parallel, or network). The reinitialization time depends on the specific hardware configuration of the MFP, such as the number of EIO devices installed, the presence of external paper-handling devices, and the amount of memory installed.

If the remote firmware update process is interrupted before the firmware is downloaded (when **RECEIVING UPGRADE** appears on the control panel), the firmware file must be sent again. If power is lost during the flash DIMM update (when **UPGRADING PRINTER** appears on the control panel), the update is interrupted and the message **RESEND UPGRADE** appears (in English only) on the control panel. The update must be sent only by a computer that is attached to the parallel port of the MFP.

Finally, any print jobs that are ahead of the .RFU job in the queue are printed before the update is processed.

---

**Note**

---

The MFP automatically turns off and then on again after processing the update.

---

**Note**

---

HP LJ 9040mfp/9050mfp/9500mfp: If the firmware upgrade fails during the process, you might have to use the parallel port to install the upgrade firmware. See “Remote firmware update through a local Windows port” on page 88.

---

## Remote firmware update through a local Windows port

If the MFP is connected through a local port (USB or parallel), then you can send the .RFU file directly to the MFP by using a **Copy** command from a command prompt or an MS-DOS window. At the command prompt, perform the following steps for your operating system.

### Windows 95, Windows 98, or Windows Me

- 1 From a command prompt or in an MS-DOS window, type:  
Mode lpt1:.,p

---

#### Note

If the MFP is attached to a parallel port other than LPT1, then substitute the correct LPT port number in the mode command.

- 2 Press **ENTER**.
- 3 The response that you receive should be similar to these examples:
  - LPT1 Not Rerouted
  - Resident portion of MODE loaded
  - Infinite retry on parallel printer time-out
- 4 At a command prompt, type:  
copy /b <FILENAME> <PORTNAME>

where <FILENAME> is the name of the .RFU file (including the path) and <PORTNAME> is the name of the appropriate MFP port (such as LPT1). For example, C:\>COPY/b c:\9500MFPFW.RFU" LPT1

---

#### Note

If the file name or path includes a space, you must enclose the file name or path in quotation marks. For example, type C:\>COPY/b "c:\My Documents\9500MFPFW.RFU" LPT1

- 5 Press **ENTER**. A message appears on the control panel. At the end of the upgrade process, **READY** appears on the control panel.
- 6 Print a configuration page and verify that the firmware revision number matches the revision of the current upgrade.
- 7 Type the word "exit" at the command prompt to close the command window.

### Windows NT 4.0, Windows 2000, Windows XP, or Windows Server 2003

The .RFU file can be sent directly to the MFP by typing a copy command at a command prompt or in an MS-DOS window.

- 1 At a command prompt, type:  
copy /b <FILENAME> <PORTNAME>

where <FILENAME> is the name of the .rfu file (including the path) and <PORTNAME> is the name of the appropriate MFP port (such as LPT1). For example, C:\>COPY/b c:\9500MFPFW.RFU LPT1

---

#### Note

If the file name or path includes a space, you must enclose the file name or path in quotation marks. For example, type: C:\>COPY/b "c:\My Documents\9500MFPFW.RFU" LPT1

- 2 Press **ENTER**. A message appears on the control panel. At the end of the upgrade process, **READY** appears on the control panel.
- 3 At the command prompt, type the word "exit" to close the command window.

## Remote firmware update through a Windows network

If the MFP is shared on a Windows network, follow these instructions.

- 1 From a command prompt or in an MS-DOS window, type:  
`copy /B <FILENAME> \\<COMPUTERNAME>\<SHARENAME>`

where <FILENAME> is the name of the .rfu file (including the path), <COMPUTERNAME> is the name of the computer from which the MFP is being shared, and <SHARENAME> is the MFP share name. For example, `C:\>COPY /B c:\9500MFPFW.RFW \\your_server\your_computer`

---

### Note

If the file name or path includes a space, you must enclose the file name or path in quotation marks. For example, type `C:\>COPY/b "c:\My Documents\9500MFPFW.RFU" \\your_server\your_computer`

- 2 Press **ENTER**. A message appears on the control panel. At the end of the upgrade process, **READY** appears on the control panel. The message "1 file(s) copied" appears on the computer screen.

## Remote firmware update for UNIX systems

For UNIX systems, any command method that delivers the .RFU file to the MFP is acceptable, including the following procedure:

At the command prompt, type:

```
$cp </home/yourmachine/FILENAME/dev/parallel>
```

where </home/yourmachine/FILENAME> contains the .rfu file.

## Remote firmware update by using FTP on a direct network connection

If the MFP uses a direct network connection, use file transfer protocol (FTP) to update your HP LaserJet firmware. Complete the following steps for your operating system.

### Windows operating systems

- 1 Make note of the TCP/IP address on the EIO Jetdirect page. The HP Jetdirect page is the second page of the configuration page printout.

---

#### Note

---

Before connecting to the MFP, make sure that the MFP is not in PowerSave mode. Also, make sure that any error messages are cleared from the control panel.

- 2 Open a command window on your computer.
- 3 Type:  
ftp <TCP/IP PRINTER ADDRESS>  
  
For example, if the TCP/IP address is 192.168.0.90, type ftp 192.168.0.90
- 4 Press **ENTER**.
- 5 When prompted for the user name, press **ENTER**.
- 6 When prompted for the password, press **ENTER**.
- 7 Type the word "bin" at the command prompt.
- 8 Press **ENTER**. The message "200 Types set to I, Using binary mode to transfer files" appears in the command window.
- 9 Type:  
put <FILENAME>

where <FILENAME> is the name of the .RFU file that was downloaded from the Web, including the path. For example, type:  
put C:\LJ\9500FW.RFU

and then press **ENTER**.

---

#### Note

---

If the file name or path includes a space, you must enclose the file name or path in quotation marks. For example, type put "c:\My Documents\LJ\9500MFPFW.RFU"

- 10 The following series of messages appears in the command window:

- 200 PORT command successful
- 150 Opening BINARY mode data connection
- 226 Ready
- 226 Processing Job
- 226 Transfer complete

A message containing transfer speed information appears.

- 11 The download process begins and the firmware is updated on the MFP. This can take about five minutes. Let the process finish without further interaction with the MFP or computer.

---

#### Note

---

The MFP automatically turns off and then on again after processing the upgrade.

- 12 At the command prompt, type the word "bye" to exit the ftp command.
- 13 At the command prompt, type the word "exit" to return to the Windows interface.

## Mac operating systems (OS X)

- 1 Make note of the TCP/IP address on the EIO Jetdirect page. The Jetdirect page is the second page of the configuration page printout.
- 2 Open a Terminal window on your Macintosh. You can find the Terminal program on the computer hard drive under the Programs/Utilities folder.
- 3 Type:  
FTP <TCP/IP PRINTER ADDRESS>

For example, if the TCP/IP address is 192.168.0.90, type FTP 192.168.0.90.

- 4 Press **ENTER**.
- 5 When prompted for a user name and password, press **ENTER**.
- 6 Type put:  
<path>

where <path> is the location where the .RFU file was downloaded from the Web, including the path. For example, type  
users/computername/desktop/LaserJet/FW.RFU and then press **ENTER**.

---

### Note

If the file name or path includes a space, you must enclose the file name or path in quotation marks. For example, type \My Documents\LJFW.RFU

---

### Note

To verify that the entire proper path to the .RFU file is placed in the **Put** command, type the word "put", then type a space, and then click and drag the .rfu file on to the terminal window. The complete path to the file will be automatically placed after the **Put** command.

- 7 The download process begins and the firmware is updated on the MFP. This can take about five minutes. Let the process finish without further interaction with the MFP or computer.

---

### Note

The MFP automatically turns off and then turns on again to activate the update.

## Remote firmware update by using FTP through a browser

Follow the instructions below to use FTP through a browser to update the MFP firmware remotely.

---

### Note

The following instructions can be used on Windows or Mac operating systems, and the supported browsers include Microsoft Internet Explorer 5.5 and 6.0 (Windows only) and Netscape 7.0 (English) for all operating systems.

- 1 Open a browser window.
- 2 In the address line of the browser, type:  
ftp://<IPADDRESS>

where <IPADDRESS> is the TCP/IP address of your MFP. For example, if the TCP/IP address is 192.168.0.90, type FTP 192.168.0.90

- 3 Locate the .RFU file for the MFP.
- 4 Drag and drop the .RFU file onto the PORT1 icon in the browser window.

## Remote firmware update using the HP LaserJet utility (Mac OS 8.6 and 9.x only)

Follow these instructions to update the firmware by using the HP LaserJet utility.

- The first step is to make sure that you have the tools and files that are necessary for the update. You will need the HP LaserJet utility and the XXXXMFPFW.RFU file, which is the firmware file for the MFP.

The HP LaserJet utility is contained on the MFP printing-system software CD-ROM that came with the MFP. If you do not have the software CD-ROM, you can obtain the HP LaserJet utility by downloading the latest MFP installer from [www.hp.com](http://www.hp.com).

The firmware file can be downloaded from:

- [www.hp.com/go/lj9000mfp](http://www.hp.com/go/lj9000mfp)
- [www.hp.com/go/lj9000Lmfp](http://www.hp.com/go/lj9000Lmfp)
- [www.hp.com/go/lj9040mfp](http://www.hp.com/go/lj9040mfp)
- [www.hp.com/go/lj9050mfp](http://www.hp.com/go/lj9050mfp)
- [www.hp.com/go/clj9500mfp](http://www.hp.com/go/clj9500mfp)

When you have the firmware file and the HP LaserJet utility, you are ready to begin the upgrade process.

- 1 Start the HP LaserJet utility.
- 2 Click **Select Printer** and locate the MFP that you would like to upgrade on the network.
- 3 Select the MFP on the right side of the dialog box, and click **OK**. An information dialog box for the MFP appears.
- 4 On the left side of the information dialog box, click **Files**. A dialog box appears in which you can select a file to be downloaded to the MFP.
- 5 Click **Select File**.
- 6 Locate the XXXXMFPFW.RFU file on your hard disk, and click the file name to highlight it. Then click **Select**. The **Files** dialog box updates showing the 9500MFP.RFU file under **File to download**.
- 7 Click **Download**.

The HP LaserJet utility starts downloading the file to the MFP. A progress bar keeps you updated about how much of the file has been downloaded. When the file is downloading, `RECEIVING UPGRADE` appears on the control panel. After the file downloads to the MFP, `PERFORMING UPGRADE` appears on the control panel.

---

### Note

The MFP automatically turns off and then turns on again after processing the upgrade.

- 8 After the MFP turns on again and finishes initializing, print a configuration page to make sure that the new firmware is installed. Use the control-panel information menu (HP LJ 9000mfp/9000Lmfp) or press 22 (HP LJ 9040mfp/9050mfp and HP CLJ 9500mfp) on the control panel to print a configuration page.

## Remote firmware update using the LPR command

---

### Note

This remote firmware update method is for use in Windows NT 4.0, Windows 2000, Windows XP, and Windows Server 2003.

Follow these instructions to update the MFP software remotely by using the LPR command:

- 1 In a command window, type:  
lpr -P <IPADDRESS> -S <IPADDRESS> -o l <FILENAME>  
or  
lpr -S <IPADDRESS> -Pbins <FILENAME>

where <IPADDRESS> can be either the TCP/IP address or the hostname of the MFP, and where <FILENAME> is the filename of the .rfu file.

---

### Note

The parameter (-o l) consists of a lowercase “O”, not a zero, and a lowercase “L”, not the numeral 1. This parameter sets the transport protocol to binary mode.

- 2 Press **ENTER**. A message appears on the control panel. At the end of the upgrade process, **READY** appears on the control panel.
- 3 Type the word “exit” at the command prompt to close the command window.

## Using HP Web Jetadmin to download the firmware to the MFP

This procedure requires that you install HP Web Jetadmin version 7.0 or later on your computer. Complete the following steps to update a single MFP through HP Web Jetadmin after downloading the .RFU file from the HP Web site.

- 1 Start HP Web Jetadmin.
- 2 Type the TCP/IP address or IP host name of the MFP in the **Quick Device Find** field, and then click **Go**. The MFP Status window appears.
- 3 Open the Device Management folder in the drop-down list in the Navigation panel. Navigate to the Device Lists folder.
- 4 Expand the Device Lists folder and select All Devices. Locate the MFP that you want to update in the list of MFPs and click to select it.
- 5 Locate the drop-down box for **Device Tools** in the upper-right corner of the window. Select **Update Printer Firmware** from the **Choose Action** list.
- 6 If the name of the .RFU file is not listed in the **All Available Images** box, click **Browse** in the **Upload New Firmware Image** dialog box and navigate to the location of the .RFU file that you downloaded from the Web at the start of this procedure. If the filename is listed, select it.
- 7 Click **Upload** to move the .RFU file from your hard drive to the HP Web Jetadmin server.
- 8 Refresh the browser.
- 9 Select the .RFU file from the **Printer Firmware Update** drop-down menu.
- 10 Click **Update Firmware**. HP Web Jetadmin sends the selected .RFU file to the MFP. A message appears on the control panel. At the end of the upgrade process, **READY** appears on the control panel.

HP Web Jetadmin 6.5 can be used to perform multiple or unattended installations. Use the following procedures.

- 1 Start HP Web Jetadmin.
- 2 Create a device group. A simple way to do this is to follow these steps:
  - a Click **Device Management**, and then click **All Devices**.
  - b Shift-click to select MFPs that you want to be included in the group, and then click **OK**.
  - c When prompted, type a name for the new device group, and then click **OK**.
- 3 To modify several MFPs in a group, click the group name, and then click **Open**.
- 4 The drop-down menu for **Device Group Tools** appears in the right side of the window. Scroll if necessary to view it.
- 5 In the **Device Group Tools** drop-down box, choose an action. Type in the appropriate information, and then click **Return to Device Group** when you are finished.

## MFP messages during firmware update

The MFP shows three messages that appear during a normal update process.

**Table 41. MFP messages during firmware update**

MFP message	Explanation
RECEIVING UPGRADE	Appears when the MFP recognizes the start of an .RFU update until the MFP verifies the validity and integrity of the .RFU update
UPGRADING MFP	Appears when the MFP is reprogramming the firmware
WAIT FOR MFP TO REINITIALIZE	Appears when the MFP finishes reprogramming the compact flash until the MFP reinitializes

---

### Note

---

To verify that the firmware update succeeded, print a new configuration page from the control panel and make sure that the firmware date code on the configuration page has changed.

## Troubleshooting a firmware update

The following table lists the causes and results of possible interruptions to the firmware update.

**Table 42. Troubleshooting a firmware update (1 of 2)**

Cause	Result
Control panel cancelled a job.	No update occurred.
A break in the I/O stream occurred during a send.	No update occurred.
A power cycle occurred during RECEIVING UPGRADE.	No update occurred.
A power cycle occurred during UPGRADING PRINTER.	No update occurred (resend the update through a parallel port).
A power cycle occurred during WAIT FOR MFP TO REINITIALIZE.	The update is complete.

### Note

Print jobs sent to the MFP while an update is in process do not interrupt the update.

The following table lists possible reasons for the failure of a remote firmware update and the corrective action required for each situation.

**Table 43. Troubleshooting a firmware update (2 of 2)**

Cause	Action
The .RFU file is corrupted.	The MFP recognizes that the file is corrupted and rejects the update. Download the file again and send the new file to the MFP. Download the file from: <ul style="list-style-type: none"> <li>● <a href="http://www.hp.com/go/lj9000mfp">www.hp.com/go/lj9000mfp</a></li> <li>● <a href="http://www.hp.com/go/lj9000Lmfp">www.hp.com/go/lj9000Lmfp</a></li> <li>● <a href="http://www.hp.com/go/lj9040mfp">www.hp.com/go/lj9040mfp</a></li> <li>● <a href="http://www.hp.com/go/lj9050mfp">www.hp.com/go/lj9050mfp</a></li> <li>● <a href="http://www.hp.com/go/clj9500mfp">www.hp.com/go/clj9500mfp</a></li> </ul>
The .RFU file contains the wrong MFP model.	The MFP recognizes the model mismatch and rejects the update. Download the correct file and send it to the MFP. Download the file from: <ul style="list-style-type: none"> <li>● <a href="http://www.hp.com/go/lj9000mfp">www.hp.com/go/lj9000mfp</a></li> <li>● <a href="http://www.hp.com/go/lj9000Lmfp">www.hp.com/go/lj9000Lmfp</a></li> <li>● <a href="http://www.hp.com/go/lj9040mfp">www.hp.com/go/lj9040mfp</a></li> <li>● <a href="http://www.hp.com/go/lj9050mfp">www.hp.com/go/lj9050mfp</a></li> <li>● <a href="http://www.hp.com/go/clj9500mfp">www.hp.com/go/clj9500mfp</a></li> </ul>
The upgrade is interrupted.	See previous table.
A flash hardware failure occurred.	The MFP might have a hardware failure.



# 4

## MFP maintenance

### Chapter contents

Cleaning the MFP and accessories. . . . .	98
General cleaning. . . . .	98
ADF cleaning . . . . .	99
Glass cleaning . . . . .	105

# Cleaning the MFP and accessories

---

**Note** This service manual provides information about the scanner/ADF portion of the MFP. For maintenance information about the print engine portion of this MFP, see the *HP LaserJet 9000 and 9050 Printer Service Manual*, or the *HP color LaserJet 9500/9500mfp Print Engine Service Manual*.

---

## General cleaning

---

**WARNING!** In order to avoid shock hazard, turn the MFP and the finishing device off and unplug all power cords before you begin these steps.

---

---

**CAUTION** Do not use ammonia-based cleaners on the print engine or finishing device. While cleaning the MFP, be careful not to touch the transfer or delivery rollers. Skin oils on the roller can cause print-quality problems.

---

- Clean the outside of the MFP with a water-dampened cloth.
- Clean the inside of the MFP with a dry, lint-free cloth.
- Clean the glass and the white vinyl calibration strips with an ammonia-based cleaner.

---

**CAUTION** The ADF and the glass are the only MFP components that can tolerate ammonia-based cleaners. Keep the cleaners in a location away from the MFP. Only bring the dampened cloth near the MFP, and never touch the cloth to any part of the print engine or finishing devices.

---

Promptly remove any dampened cloth after the cleaning procedure is accomplished.

---

## ADF cleaning

### To clean the ADF delivery system

Clean the ADF only if it is visibly marked or dirty, or if you are experiencing a degradation of copy quality (such as streaking).

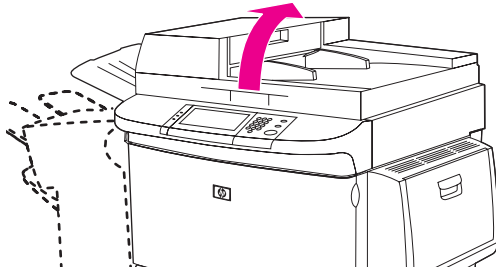
---

**WARNING!**

---

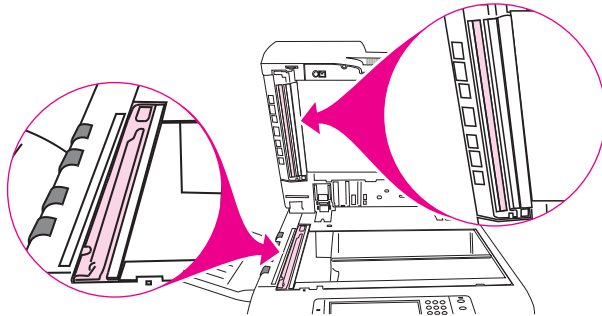
In order to avoid shock hazard, turn the print engine and the finishing devices off and unplug all power cords before you begin these steps.

- 1 Lift the ADF.



**Figure 14.** ADF delivery system (1 of 5)

- 2 Locate the top and bottom ADF glass strips.



**Figure 15.** ADF delivery system (2 of 5)

- 3 Clean the ADF glass strips by wiping them gently with a clean, damp, lint-free cloth. Use an ammonia-based surface cleaner to dampen the cloth.

---

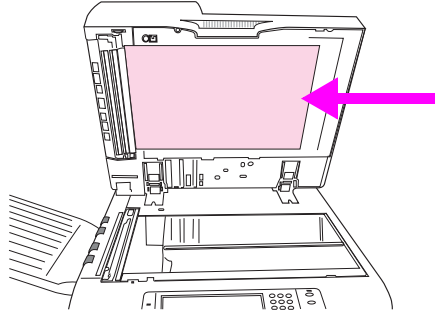
**CAUTION**

---

The ADF and the glass are the only MFP components that can tolerate ammonia-based cleaners. Keep the cleaners in a location away from the MFP. Only bring the dampened cloth near the MFP, and never touch the cloth to any part of the print engine or finishing devices.

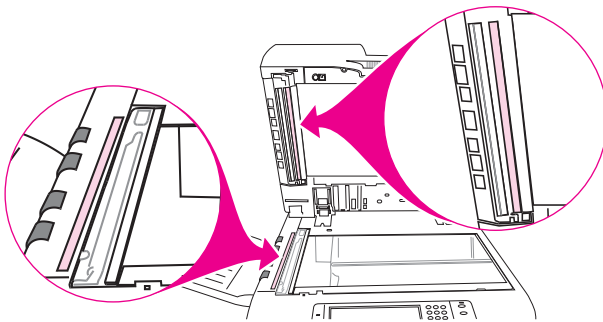
Promptly remove any dampened cloth after the cleaning procedure is accomplished.

- 4 Locate the white board.



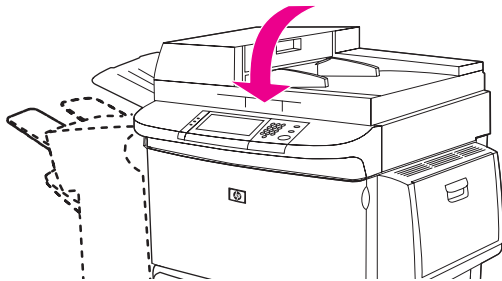
**Figure 16.** ADF delivery system (3 of 5)

- 5 Locate the white, vinyl calibration strips.



**Figure 17.** ADF delivery system (4 of 5)

- 6 Clean the ADF backing and the calibration strips by wiping them with a clean, damp, lint-free cloth. Use an ammonia-based surface cleaner to dampen the cloth.
- 7 Close the ADF.



**Figure 18.** ADF delivery system (5 of 5)

## To clean the upper ADF glass strip

If you continue to experience poor copy quality, you might need to clean the upper ADF glass strip.

### CAUTION

Clean this area only if you see copy defects such as streaks, and you notice dust inside the glass strip. Cleaning this area frequently could introduce dust into the MFP.

### WARNING!

In order to avoid shock hazard, turn the MFP and the finishing device off and unplug all power cords before you begin these steps.

- 1 Open the ADF feeder.

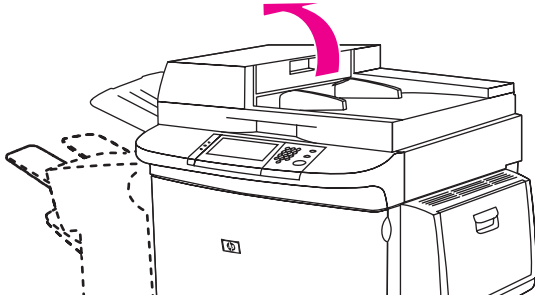


Figure 19. Upper ADF glass strip (1 of 4)

- 2 Locate the latch that releases the upper ADF glass strip. Push the latch to the left, and then pull the latch down to expose the inside of the glass strip.

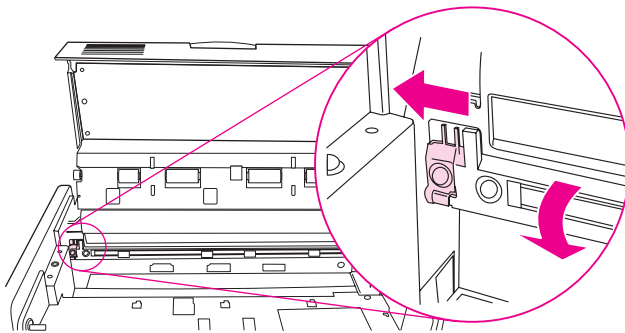


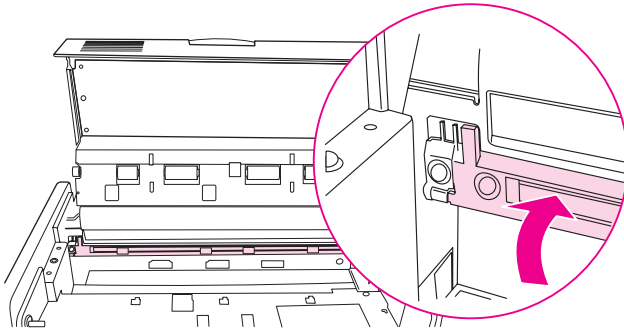
Figure 20. Upper ADF glass strip (2 of 4)

### CAUTION

Use dry cloth only in this area. Do not use solvents, cleaners, water, or compressed air. Doing so could severely damage the MFP.

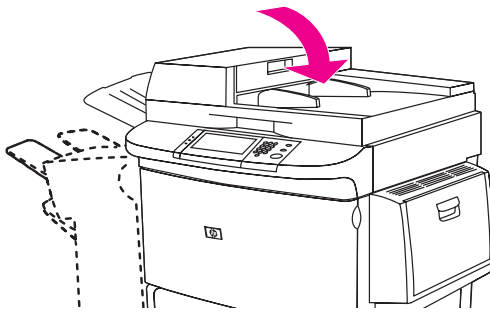
- 3 Gently wipe the glass with a dry, lint-free cloth.

- 4 Pull up the latch to return the glass strip to its normal position.



**Figure 21.** Upper ADF glass strip (3 of 4)

- 5 Close the ADF feeder.



**Figure 22.** Upper ADF glass strip (4 of 4)

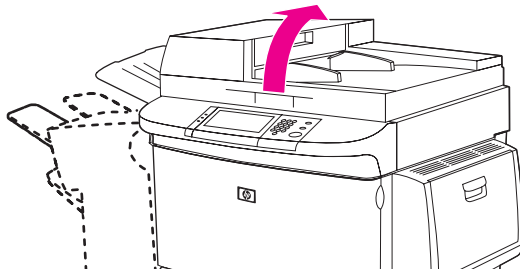
## To clean the ADF rollers

If the user is experiencing poor scan quality or several misfeeds, the ADF rollers might need to be cleaned.

### CAUTION

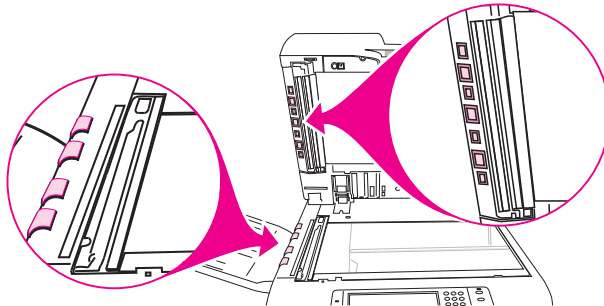
Clean the rollers only if the user experiences misfeeds or marks on the originals, or if you notice dust on the rollers. Cleaning the rollers frequently could introduce dust into the MFP.

- 1 Lift the ADF.



**Figure 23.** ADF rollers (1 of 6)

- 2 Locate the delivery rollers.
- 3 Wipe the rollers gently with a clean, water-dampened, lint-free cloth.

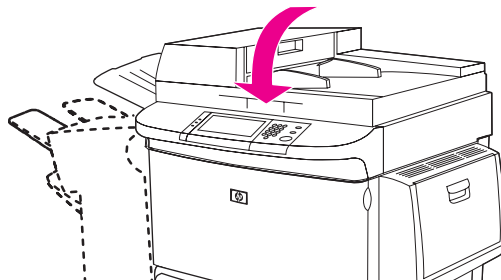


**Figure 24.** ADF rollers (2 of 6)

### CAUTION

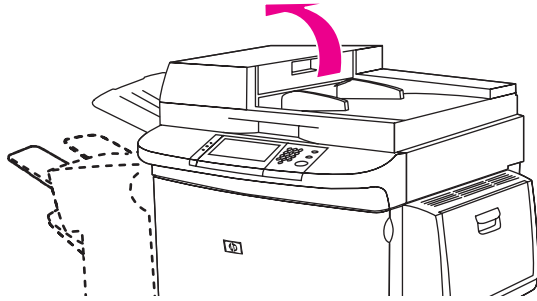
Do not pour water directly onto the rollers. Doing so might damage the MFP.

- 4 Close the ADF.



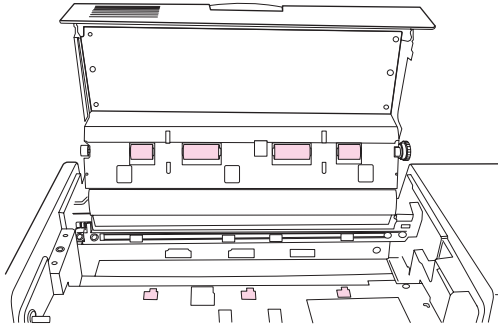
**Figure 25.** ADF rollers (3 of 6)

- 5 Open the ADF feeder.



**Figure 26.** ADF rollers (4 of 6)

- 6 Locate the registration rollers.
- 7 Wipe the rollers with a clean, water-dampened, lint-free cloth.

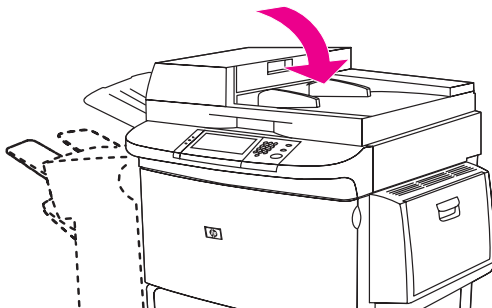


**Figure 27.** ADF rollers (5 of 6)

**CAUTION**

Do not pour water directly onto the rollers. Doing so might damage the MFP.

- 8 Close the ADF feeder.



**Figure 28.** ADF rollers (6 of 6)

## Glass cleaning

### To clean the glass

Clean the glass only if dirt is visible, or if you see poor copy quality (such as streaking).

Clean the glass surface by wiping it gently with a clean, damp, lint-free cloth. Use an ammonia-based surface cleaner to dampen the cloth.

---

**CAUTION**

The ADF and the glass are the only MFP components that can tolerate ammonia-based cleaners. Keep the cleaners in a location away from the MFP. Only bring the dampened cloth near the MFP, and never touch the cloth to any part of the print engine or accessories.

Promptly remove any dampened cloth after the cleaning procedure is accomplished.

Do not pour or spray liquids directly onto the glass.

---

Do not press hard on the glass surface. You might break the glass.



# 5

## Theory of operation

### Chapter contents

Differences in MFPs .....	108
Mechanical structure .....	110
Motors and fans .....	112
Basic block diagram .....	114
Basic system configuration .....	115
Scanner unit systems .....	115
Scan mode .....	116
Power supply assembly .....	117
PowerSave (sleep) mode (HP LJ 9000mfp/9000Lmfp) .....	119
Sleep mode (HP LJ 9040mfp/9050mfp/9500mfp) .....	120
Low-voltage power supply circuit .....	122
Scanner controller circuit .....	124
Flatbed operation .....	125
Flatbed document exposure control .....	125
Flatbed optical drive control .....	126
Flatbed optical unit operation .....	127
Flatbed document size detection .....	128
ADF operation .....	131
ADF document exposure control .....	131
ADF document feed control .....	132
ADF document size detection .....	134
ADF feeder sensors .....	135
ADF document skew detection .....	136
Scanned data flow .....	137
Copy processor .....	138
Scanning process control signals .....	139
Typical scanning process flow .....	139
Copy processor LEDs (HP LJ 9000mfp/9000Lmfp) .....	140
Copy processor LEDs (HP LJ 9040mfp/9050mfp/9500mfp) .....	142

## Differences in MFPs

The following tables provide a list of components that are different between the HP LaserJet 9000 Series printer, the HP LaserJet 9000mfp/9000Lmfp print engine, HP LaserJet 9040mfp/9050/mfp, and the HP LaserJet 9500mfp. Part numbers applicable to their respective engine are provided.

**Note** For troubleshooting purposes, the HP LaserJet 9000 series face-up tray can be used with the HP LaserJet 9000mfp, but the HP LaserJet 9000mfp does not ship with the face-up tray.

**Note** The flapper can keeps the diverter assembly in a constant state for diverting paper to the left output tray.

**Table 44. Differences between the LJ 9000mfp/9000Lmfp and the LJ 9040mfp/9050mfp**

Item	HP LJ 9000 series	HP LJ 9000mfp HP LJ 9000Lmfp	HP LJ 9040mfp/9050mfp	Qty
Control panel assembly	RG5-5703-000CN	RG5-5734-000CN	5851-1838	1
Control panel cable	N/A	RG5-5752-000CN	RG5-5752-000CN	1
Cover, left upper cover	RG5-5705-000CN	RG5-5706-000CN	RG5-5706-000CN	1
Cover, top left	RB2-5660-000CN	N/A	N/A	1
Cover, top right	RB2-5659-000CN	N/A	N/A	1
Delivery assembly	RG5-5643-030CN	RG5-5642-000CN	RG5-5642-000CN	1
Face-down tray fan	RH7-5302-000CN	N/A	N/A	1
Grounding cable	N/A	RG5-5736-000CN	RG5-5736-020CN	1
Holder, lock	N/A	RB2-6495-000CN	RB2-6495-000CN	4
Power supply cable	N/A	RG5-5735-000CN	RG5-5735-000CN	1
Tray, face-up	RB2-5690-000CN	N/A	N/A	1

**Table 45. Differences between the LJ 9000mfp/9000Lmfp and the CLJ 9500mfp**

Scanner/ADF components			
Item	HP LJ 9000mfp HP LJ 9000Lmfp	HP LaserJet 9500mfp	Qty
Scanner controller PCB	RH5-3075-000CN	RH5-3122-000CN	1
Flatbed optical assembly	RG5-6263-000CN	RG5-7374-000CN (lamps and inverters are <i>not</i> available as separate parts)	1
Paper pickup assembly	RG5-6275-000CN (not previously available)	RG5-6275-000CN	1
ADF main assembly	N/A	RG5-7379-000CN	1
ADF optical assembly	RH7-3065-000CN (lamps and inverters are available as separate parts)	RG5-7380-000CN (lamps and inverters are <i>not</i> available as separate parts)	1
Cable, CCD	RH2-5453-000CN (not previously available)	RH2-5453-000C	1

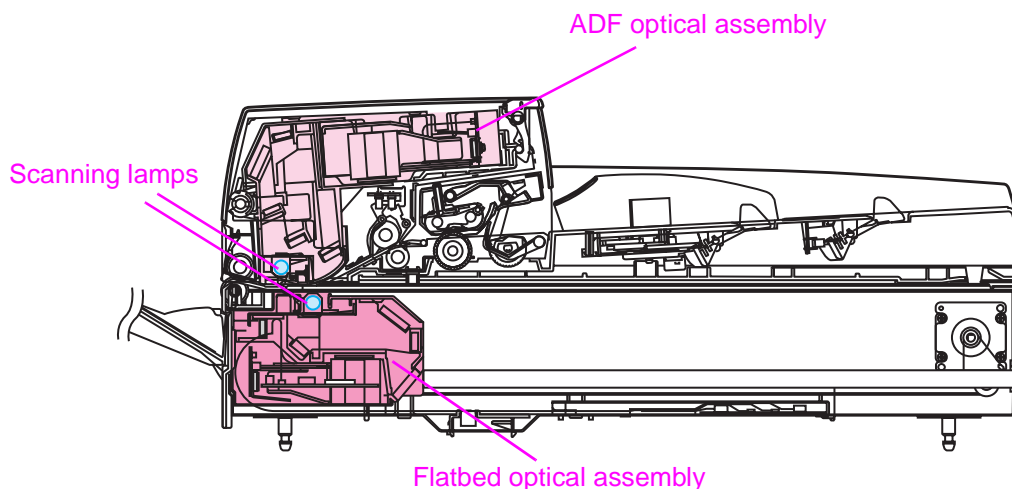
**Table 46. Differences between the LJ 9040mfp/9050mfp and the CLJ 9500mfp**

<b>Scanner/ADF components</b>			
<b>Item</b>	<b>HP LJ 9040mfp HP LJ 9050mfp</b>	<b>HP LaserJet 9500mfp</b>	<b>Qty</b>
Flatbed sensor assembly	RG5-7807-000CN	RG5-6259-000CN	1
Intermediate PCB case assembly	RG5-7806-000CN	RG5-6260-000CN	1
Scanner controller PCB	RH5-3075-000CN	RH5-3122-000CN	1
Flatbed optical assembly	RG5-6263-000CN	RG5-7374-000CN	1
ADF main assembly	RG5-6300-000CN	RG5-7379-000CN	1
ADF optical assembly	RG5-6307-000CN	RG5-7380-000CN	1
Intermediate PCB	RH5-3165-000CN	RH2-3074-000CN	

## Mechanical structure

**Note** The lamp cannot be replaced as a separate component for the HP LJ 9040/9050mfp or the HP CLJ 9500mfp. You must replace the entire optical assembly for these models.

The ADF optical assembly and the flatbed optical assembly both have a complete scanning system. This enables single-pass duplex scanning of a document.

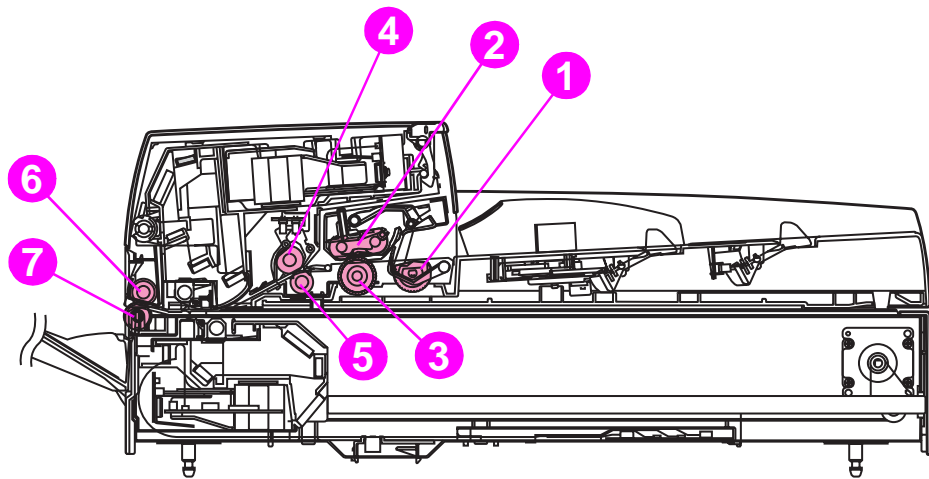


**Figure 29.** Mechanical structure (1 of 2)

**Note** When you order the ADF or flatbed optical assemblies using the part numbers in the table below, you will receive the entire assembly, including the lamp, lens, and mirrors.

**Table 47. Mechanical structure**

Description	Part number	Qty
ADF optical assembly	RG5-6307-000CN (LJ 9000mfp/9000Lmfp/ 9040mfp/9050mfp) RG5-7380-000CN (CLJ 9500mfp)	1
lamp assembly (includes shading filter)	RG5-6322-000CN (LJ 9000mfp/9000Lmfp only)	1
lens	N/A	1
mirrors	N/A	5
Flatbed optical assembly	RG5-6263-000CN (LJ 9000mfp/9000Lmfp/ 9040mfp/9050mfp) RG5-7374-000CN (CLJ 9500mfp)	1
lamp assembly (includes shading filter)	RG5-6323-000CN (LJ 9000mfp/9000Lmfp only)	1
lens	N/A	1
mirrors	N/A	5



**Figure 30.** Mechanical structure (2 of 2)

**Table 48. Mechanical structure**

Ref	Description	Part number	Qty
1	Pickup roller	RB2-7961-000CN	1
2	Separation belt assembly (belt, timing)	RB2-7988-000CN	4
3	Feed roller assembly	RB2-6281-000CN	1
4	Upper registration roller assembly	RG5-6304-000CN	1
5	Lower registration roller assembly	RG5-6277-000CN	1
6	Upper delivery roller assembly	RB2-7969-000CN	1
7	Lower delivery rollers	RB2-7884-000CN	4

## Motors and fans

The scanner uses three dc stepping motors. Two of the stepping motors drive the ADF unit rollers, and the other stepping motor drives the flatbed optical unit:

- The flatbed motor rotates in one direction to drive the flatbed optical unit when scanning is from the glass. The flatbed motor rotates in the opposite direction to position the flatbed optical unit for scanning from the ADF frontside.
- The pickup motor rotates in one direction to rotate the pickup and feed rollers. The pickup motor rotates in the opposite direction to rotate the registration rollers.
- The delivery motor rotates the delivery rollers.

The three fans are for the ADF, the flatbed, and the power supply:

- The ADF fan assembly includes a fan housing. The ADF fan is an intake fan.

### Note

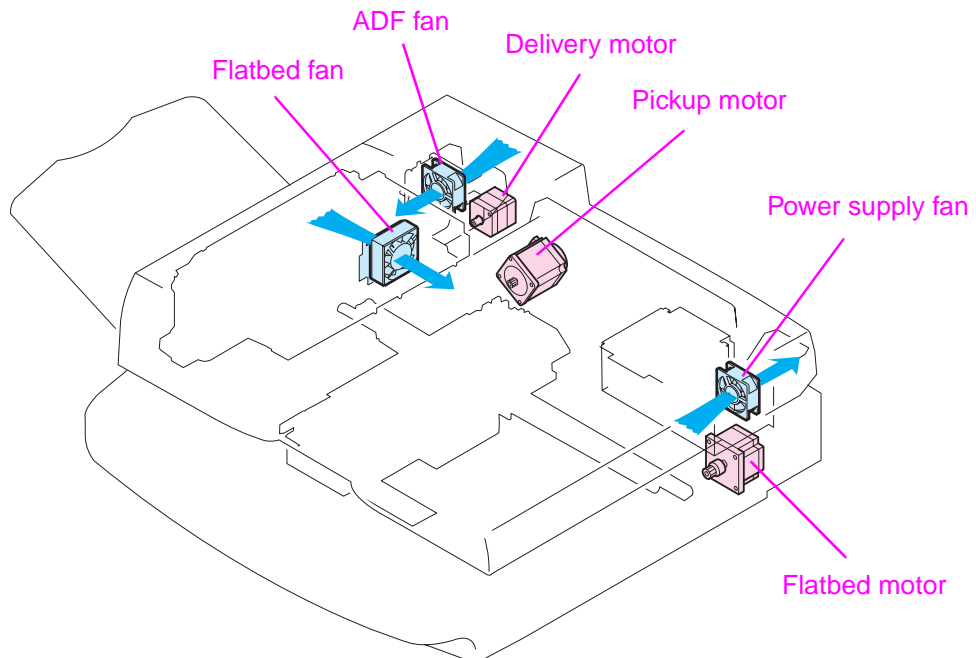
The ADF fan can be ordered separately or with its plastic housing.

- The flatbed fan assembly includes a filter. The flatbed fan is an intake fan.

### Note

The flatbed fan assembly filter only needs to be replaced when replacing the flatbed fan.

- The power supply fan is an exhaust fan.



**Figure 31. Motors and fans**

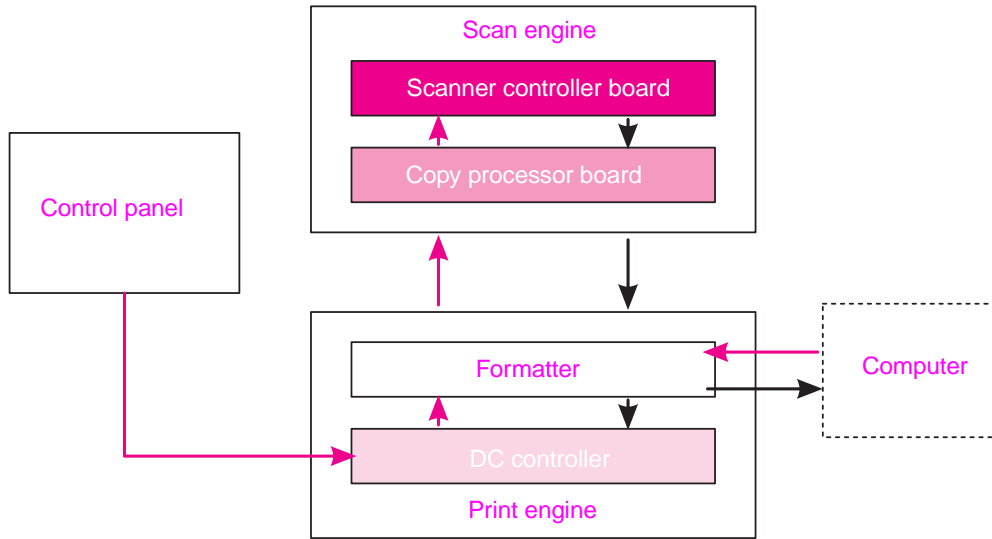
**Table 49. Motors and fans**

<b>Description</b>	<b>Part number</b>	<b>Qty</b>
ADF fan	RH7-1486-000CN	1
ADF fan assembly	RG5-6312-000CN	1
Delivery motor (24 vdc)	RH7-1487-000CN	1
Flatbed fan assembly	RG5-6318-000CN	1
Flatbed motor (24 vdc)	RH7-1485-000CN	1
Pickup motor (24 vdc)	RH7-1488-000CN	1
Power supply assembly (fan included)	RG1-4153-000CN	1

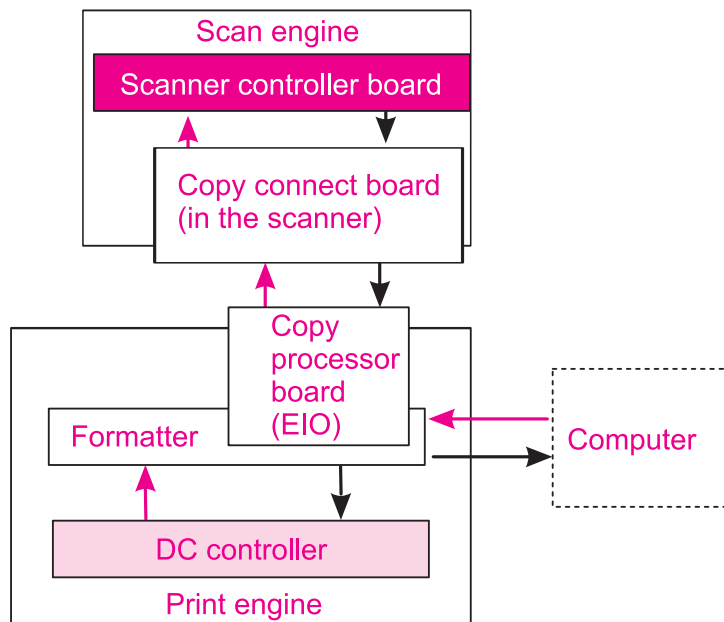
# Basic block diagram

The CP processes most jobs at the scan engine and sends the data to the print engine in the form of hardware ready bits (HRB). The formatter performs three processing tasks: n-up, book copying, and image rotation. When one of these tasks is performed, data is sent to the formatter in PCL-XL format.

The formatter sends a scan command to the CP after it receives a scan command from the control panel by way of the dc controller. The CP then sends a scan command to the scanner controller board (SCB). The SCB generates the image data and sends the image data back to the CP which, in turn, passes the image back to the formatter. Depending on the original request from the control panel (n-up, book copying, or image rotation), the formatter completes the processing. The data is then passed to the dc controller for printing, or is passed to a computer for digital sending.



**Figure 32.** Basic block diagram for the HP LJ 9000mfp/9000Lmfp



**Figure 33.** Basic block diagram for the HP LJ 9040mfp/9050mfp and the HP CLJ 9500mfp

# Basic system configuration

## Scanner unit systems

---

**Note**

---

The HP LJ9040/950mfp and the HP CLJ 9500mfp use different ADF and flatbed optical assemblies than the HP LJ 9000mfp/9000Lmfp.

The five main systems in the scanner unit include the following:

- ADF document feed system
  - ADF output tray
  - ADF feeder
  - ADF input tray
- ADF document exposure system
  - scanning lamp
  - document
  - optical path
- flatbed document exposure system
  - scanning lamp
  - document
  - optical path
  - optical drive unit
  - detection unit (home position sensor)
- image processing system
  - ADF analog processor
  - ADF CCD (charge coupled device) driver
  - flatbed analog processor
  - flatbed CCD driver
- scanner control system
  - scanner controller board (SCB)

## Scan mode

The functions based on a scan mode include:

- **ADF duplex mode:** controlled by the ADF document feed system, ADF document exposure system, flatbed document exposure system, and image processing system.
- **ADF simplex mode:** controlled by the ADF document feed system, flatbed document exposure system, and image processing system.
- **Flatbed mode:** controlled by the flatbed document exposure system and image processing system.

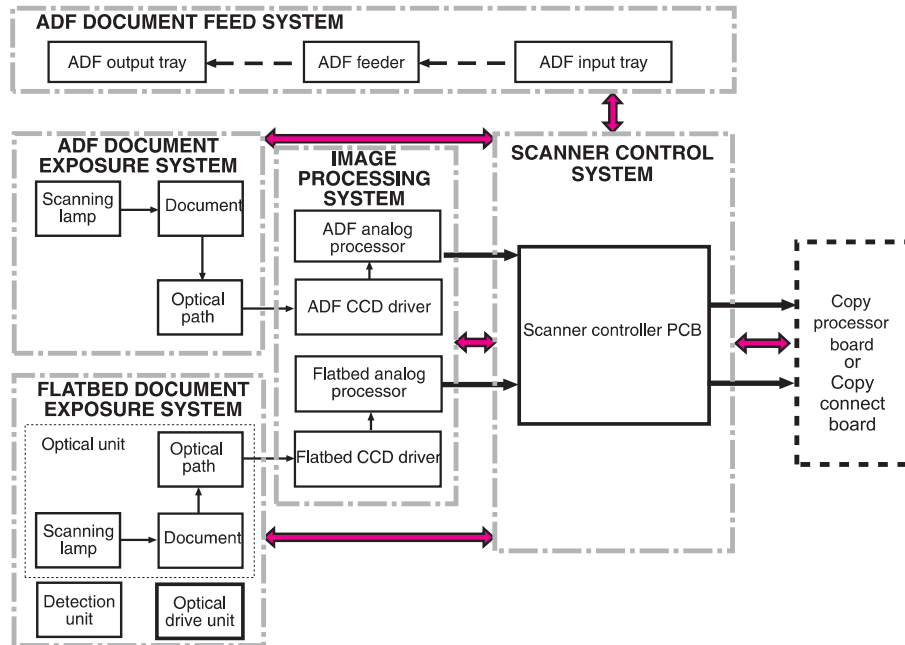


Figure 34. Basic system configuration

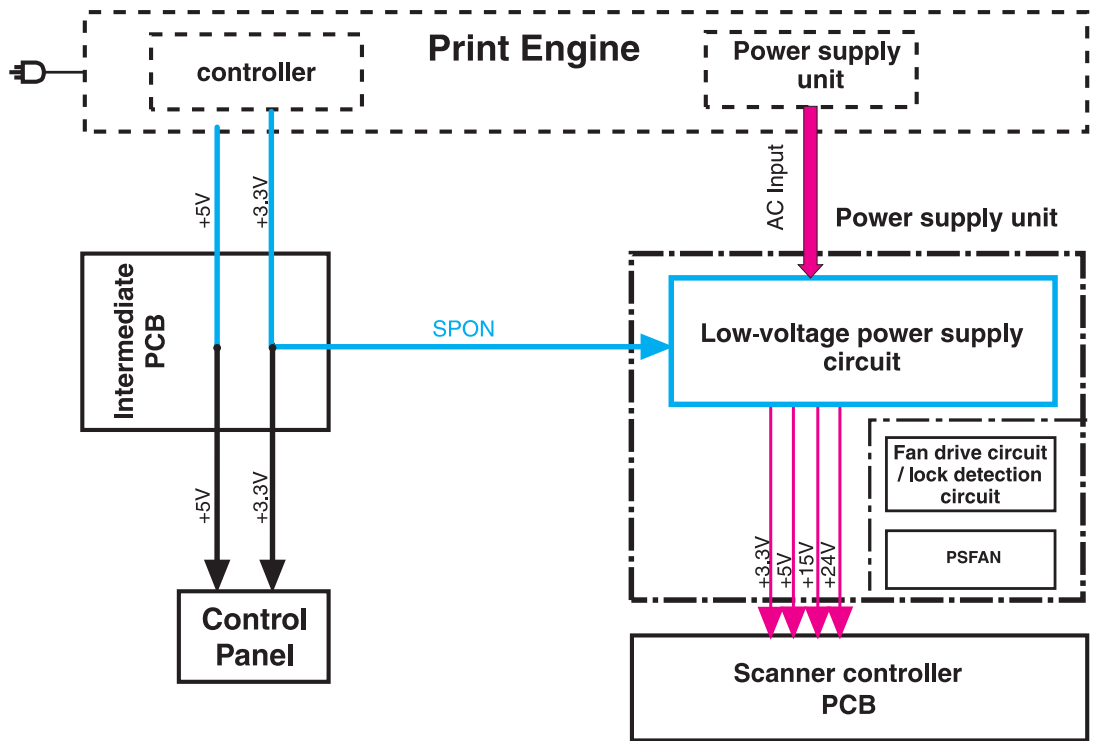
## Power supply assembly

### CAUTION

Alternating current (ac) is always on. Even if the MFP is off, the scan engine power supply is supplied with ac from the print engine power supply. Make sure you unplug the MFP before beginning any service on the MFP.

**Table 50. Electrical specifications**

Volts	Frequency	Amperes (amps)	Watts (W) (typical)	Thermal units per hour (Btu/hr)
HP LaserJet 9000mfp/9000Lmfp <sup>1</sup>				
100-127 Vac ± 10 percent	50/60 Hz ± 2 Hz	Minimum recommended current capacity = 15-amp dedicated circuit	printing = 1,075 W standby = 440 W PowerSave 1 = 70 W low power = 230 W off = .5 W ADF printing = 1,130 W	printing = 3,670 Btu/hr standby = 1,500 Btu/hr PowerSave 1 = 240 Btu/hr low power = 785 BTu/hr off = 1.7 Btu/hr ADF printing = 3,860
220-240 Vac ± 10 percent	50/60 Hz ± 2 Hz	Minimum recommended current capacity = 6.5 amp	printing = 1,070 W standby = 415 W PowerSave 1 = 70 W low power = 230 W off = 1.3 W ADF printing = 1,075 W	printing = 3,650 Btu/hr standby = 1,420 Btu/hr PowerSave 1 = 240 Btu/hr low power = 785 Btu/hr off = 4.5 Btu/hr ADF printing = 3,670
HP LaserJet 9040mfp/9050mfp <sup>1</sup>				
100-127 Vac ± 10 percent	50/60 Hz ± 2 Hz	Minimum recommended current capacity = 15-amp dedicated circuit	printing = 1,040 W standby = 265 W PowerSave 1 = 40 W PowerSave 2 = 25 W off = 0 W	printing = 3,550.36 Btu/hr standby = 904.71 Btu/hr PowerSave 1 = 136.56 Btu/hr PowerSave 2 = 85.35 Btu/hr off = 0 Btu/hr
220-240 Vac ± 10 percent	50/60 Hz ± 2 Hz	Minimum recommended current capacity = 6.5-amp dedicated circuit	printing = 995 W standby = 265 W PowerSave 1 = 40 W PowerSave 2 = 25 W off = 0.2 W	printing = 3,396.93 Btu/hr standby = 904.71 Btu/hr PowerSave 1 = 136.56 Btu/hr PowerSave 2 = 85.35 Btu/hr off = 0.69 Btu/hr
HP color LaserJet 9500mfp <sup>1</sup>				
100-127 Vac ± 10 percent	50/60 Hz ± 2 Hz	Minimum recommended current capacity = 15-amp dedicated circuit	printing* = 820 W copying* = 990 W ready = 240 W Sleep 1 = 142 W Sleep 2 = 49 W off = 2 W *24 PPM	printing = 2797.84 Btu/hr copying = 3377.88 Btu/hr ready = 818.88 Btu/hr Sleep 1 = 484.50 BTu/hr Sleep 2 = 167.18 Btu/hr off = 6.82 Btu/hr
220-240 Vac ± 10 percent	50/60 Hz ± 2 Hz	Minimum recommended current capacity = 7 amp	Same as the 110 Vac model.	Same as the 110 Vac model.



**Figure 35. Power supply assembly**

**Note**

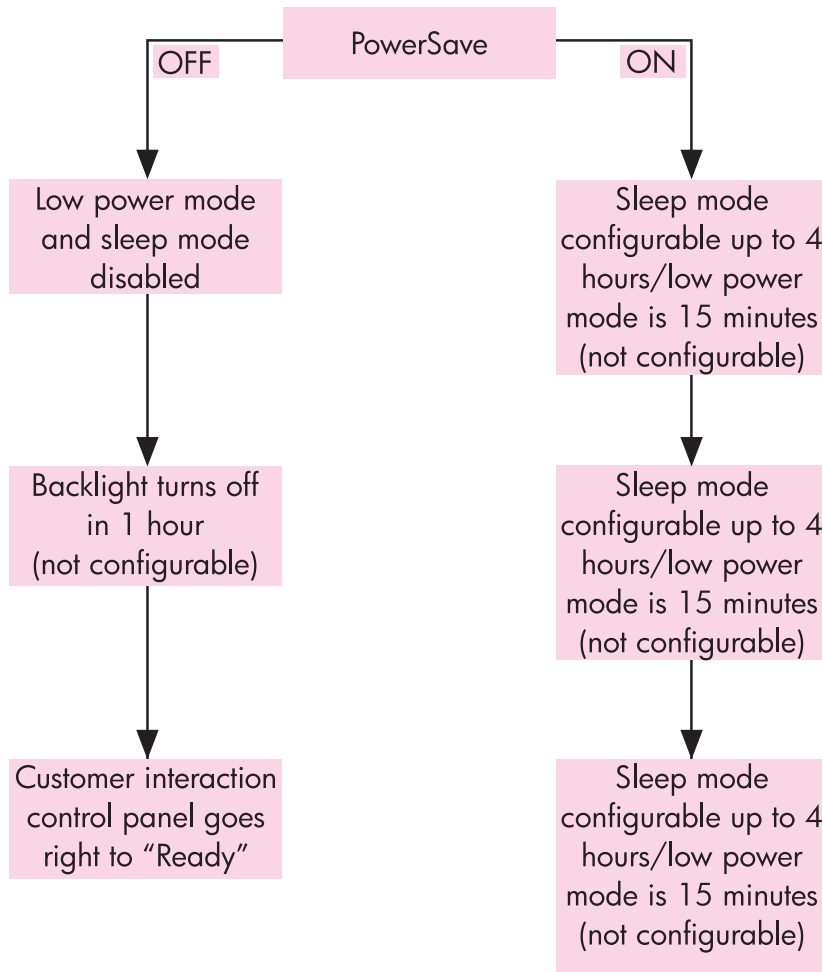
When the control panel backlight is off, the +5V line is being signaled off at the control panel assembly by the control panel controller board. SPON is the scanner power-on signal sent to the scan engine power supply when the MFP is powered on by pressing the power switch on the print engine. See "Low-voltage power supply circuit" on page 122 for more information.

## PowerSave (sleep) mode (HP LJ 9000mfp/9000Lmfp)

To extend the life of the control panel backlight, the lamp is turned off when the MFP goes into sleep mode. If the sleep mode has been disabled (PowerSave is turned off), the control panel backlight will turn off after an hour of no activity.

**Table 51. Powersave mode (HP LJ 9000mfp/9000Lmfp)**

Setting	Description
PowerSave on	<p>Sleep mode is configurable up to 4 hours/low power mode is 15 minutes (not configurable).</p> <p>The control-panel backlight turns off in sleep mode.</p> <p>Control panel goes to <code>WARMING UP</code>.</p> <p>* The customer can use the control panel (e.g. setup for and scan ahead a 50-page job from the ADF while the MFP is “warming up”).</p>
PowerSave off	<p>Low power mode and sleep mode disabled.</p> <p>The control-panel backlight turns off in 1 hour (not user configurable).</p> <p>Control panel goes right to <code>READY</code>.</p>



**Figure 36.** HP LJ 9000mfp/9000Lmfp

## Sleep mode (HP LJ 9040mfp/9050mfp/9500mfp)

To extend the life of MFP components and to meet Energy Star energy use guidelines, the MFP uses a sleep mode to conserve energy use. To further extend the life of the control panel backlight, the backlight will turn off after 15 minutes of MFP inactivity (the backlight also turns off when the MFP enters sleep mode). Table 52 below, describes the energy use behavior of the MFP components when the MFP is in sleep mode.

Sleep mode 1 is not configurable. The MFP enters sleep mode 1 after 15 minutes of inactivity. Sleep mode 2 is configurable. The MFP enters sleep mode 2 after 45 minutes (default setting; this setting is user configurable) of inactivity.

### Note

Sleep mode can be enabled or disabled by using the control panel menus (RESETS submenu) or by pushing the **SLEEP** button on the control panel. Pushing the **SLEEP** button while the MFP is in the READY (waiting for a print job) state begins the sleep mode (sleep mode 2). Pushing the **SLEEP** button while the MFP is in sleep mode, returns the MFP to the READY state.

Sleep mode 1 is defined as a level of MFP power consumption of less than that used when the MFP is in the READY (waiting for a print job) state, and more than that used when in sleep mode 2. Sleep mode 1 begins when the MFP has been inactive for 15 minutes (the 15 minute delay time is not configurable). Sleep mode 1 is the equivalent of the Energy Star program “Low Power” mode.

Sleep mode 2 is defined as the lowest level of MFP power consumption possible without the MFP power being turned off. Sleep mode 2 begins after the MFP has been inactive for the amount of time that is set in the SYSTEM SETUP menu SLEEP DELAY sub menu (45 minutes is the default setting).

### Note

When the SLEEP MODE setting in the RESETS submenu is set to OFF, and a SLEEP DELAY setting is selected in the SYSTEM SETUP menu, the SLEEP MODE setting in the RESETS submenu is automatically set to the ON or OFF option (which ever was the last saved option).

**Table 52. System behavior in sleep mode**

Item	Sleep mode	Behavior	Description
Control panel	Sleep mode 2	Backlight turns off.	The control-panel backlight is turned off when sleep mode 2 begins.
External paper handling devices	Sleep mode 1 and 2	Power turned off.	Power to the external paper handling devices is turned off when sleep mode 1 begins. The power remains off during sleep mode 2.
Formatter	Sleep mode 1 and 2	Processor slow down.	The microprocessor on the formatter slows to 1/16th speed when sleep mode 1 begins, and continue to run at this speed during sleep mode 2.
	Sleep mode 1 and 2	Color ASIC clock disabled (color MFPs only).	The color ASIC clock is disabled when sleep mode 1 begins. The clock is stays disabled during sleep mode 2.
	Sleep mode 2	Hard disk stops.	The hard disk is stopped when sleep mode 2 begins.

**Table 52. System behavior in sleep mode (continued)**

<b>Item</b>	<b>Sleep mode</b>	<b>Behavior</b>	<b>Description</b>
Engine	Sleep mode 1	Fuser fan slows down.	The fuser fan slows to half speed when sleep mode 1 begins.
	Sleep mode 1	Face down fan slows down (LJ 9040mfp/9050mfp only)	The face down fan slows to half speed when sleep mode 1 begins.
	Sleep mode 1	Fuser power decreases.	The fuser power is decreased when sleep mode 1 begins.
	Sleep mode 2	Fuser power off.	The fuser power is turned off when sleep mode 2 begins.
	Sleep mode 2	Duplexer power off.	The duplexer power is turned off when sleep mode 2 begins.

## Low-voltage power supply circuit

Opening the feeder cover switch cuts power to the ADF scanning lamp, pickup motor, delivery motor, and the solenoids.

The power supply unit generates dc power required in the scan engine based on the ac voltage supplied from the print engine power supply.

The remote switch is employed as a power switch of the scan engine. Of the voltages supplied from the print engine dc controller to the power supply of the scan engine, 3.3 vdc are used as a remote signal. The signal is supplied to the power supply unit as the power remote signal (SPON) through the intermediate circuit. When the signal is "H," the low-voltage power supply circuit generates the ac power to the dc power. The power generated in the circuit is converted to +24 vdc, +15 vdc, +5 vdc, and +3.3 vdc required in the scan engine. The +24 vdc is supplied to the motors, solenoids, and scanning lamps; +15 vdc to the sensors, LEDs, and ICs in the SCB; and +3.3 vdc to the CP.

The +24 vdc is divided into the +24 vb and +24 va. The +24 vb is constantly supplied from the low-voltage power supply circuit, and the +24 va stops power supply when the feeder cover switch (JMCSW) is turned off by opening the ADF feeder cover. The +24 va is supplied to the scanning lamps, pickup motors, delivery motors, and solenoids. It also functions as the ADF FEEDER COVER OPEN DETECTION signal, and allows the CPU to detect an open cover.

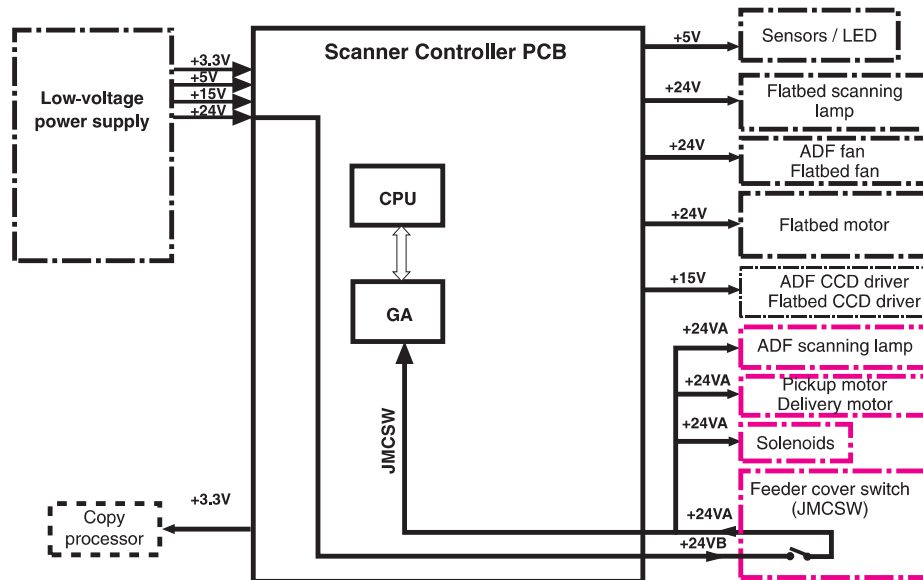
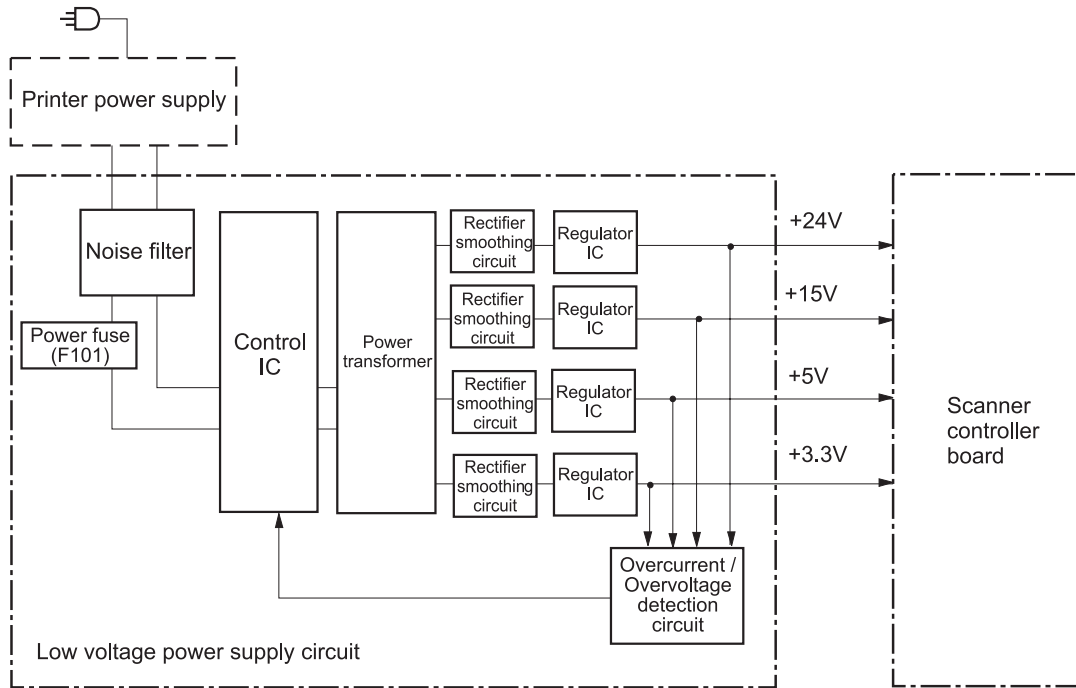


Figure 37. Low-voltage power supply circuit

## Protective functions

The low-voltage power supply circuit utilizes overcurrent and overvoltage protective functions. The protective functions automatically interrupt output voltage to prevent power supply failures. These failures occur from an excessive current flow that is caused by a short circuit on the load side, or from an abnormal voltage increase.

When the dc voltage is not output from the low-voltage power supply circuit, the overcurrent or overvoltage protective function might be activated. If it is activated, turn off the printer, correct the problem in the failure loads, wait about two minutes, and then turn on the printer. The circuit contains a power fuse (F1) which breaks and cuts off the power supply if overcurrent flows through the ac line.



**Figure 38.** Printer power supply

## Scanner controller circuit

The CPU on the SCB controls the operation sequences of the scan engine. When the dc power is supplied to the scanner controller, the CPU starts to control the scan engine. When the scan engine is in standby status, the CPU outputs signals to drive each load of charge-coupled devices (CCDs), motors, solenoids, and scanning lamps based on a scan command from the CP.

- **CPU (IC7):** According to the control programs stored in the ROM (IC5), the CPU performs:
  - image scanner sequence control
  - communication with the copy processor control
  - pickup motor and delivery motor drives control
- **GA (Gate Array) (IC4):** According to commands from the CPU, the GA performs:
  - scanning lamp drive control
  - sensors, switches, and LEDs control
  - solenoids control
  - fan motors control
  - flatbed document scanning motor control
- **EEPROM (IC16):** The EEPROM stores the specific backup adjustment data of the scanner, such as the leading-edge registration adjustment values and horizontal registration adjustment values.
- **ROM (IC5):** Stores the scanner control programs.
- **Pickup motor driver IC (IC3):** Drives the pickup motor based on commands from the CPU.
- **Delivery motor driver IC (IC1):** Drives the delivery motor based on commands from the CPU.
- **Flatbed document scanning motor driver IC (IC9):** Drives the flatbed scanning motor based on commands from the GA.
- **Reset IC (IC17):** Monitors +3.3V, and resets the CPU and GA when the power is turned on.

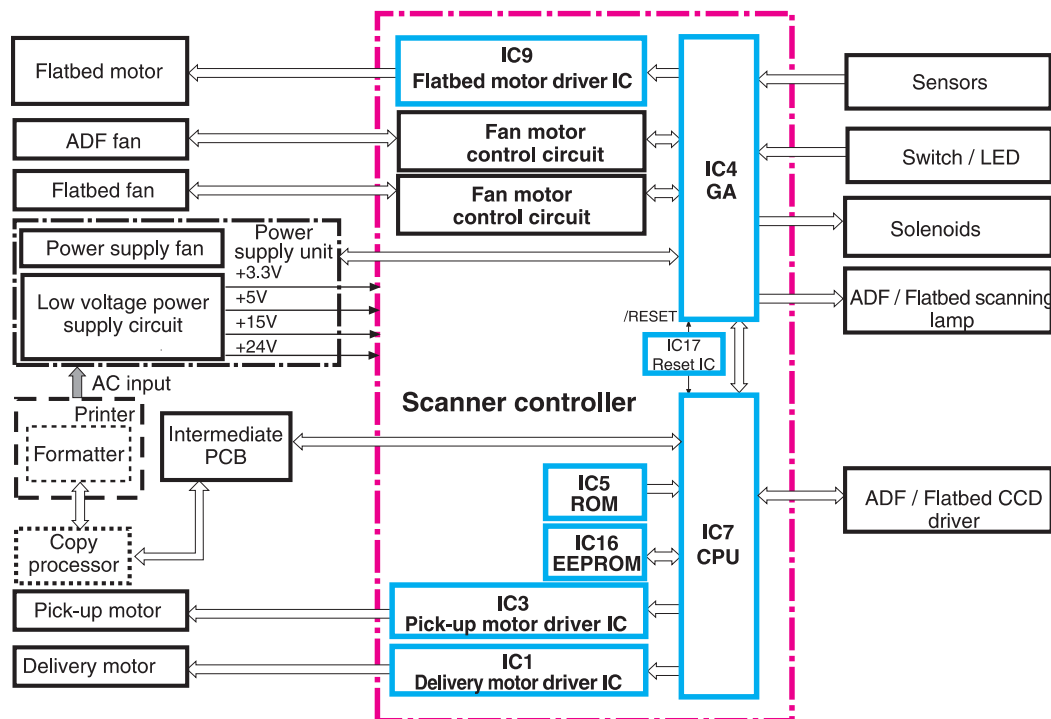


Figure 39. Scanner controller circuit

# Flatbed operation

## Flatbed document exposure control

The SCB sends a signal (FBLAMP) to the flatbed inverter to turn on the scanning lamp. The flatbed intermediate PCB and flatbed analog processor board pass on the signal. The flatbed inverter sends the signal to the scanning lamp and the document exposure process begins.

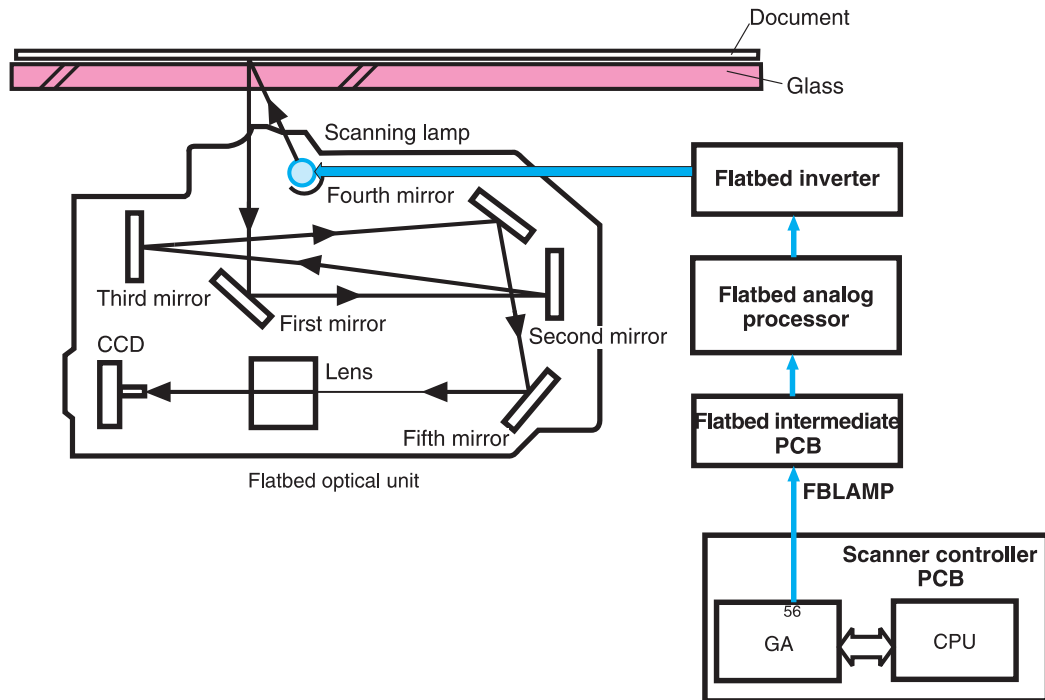


Figure 40. Flatbed document exposure control

## Flatbed optical drive control

The SCB sends a signal (CRMOT) to the flatbed motor to drive the flatbed optical unit forward to scan from the glass, or backward when scanning from the ADF frontside.

HP-S is the flatbed home position detection sensor. When the flatbed optical unit is in the home position, a signal (HP-S) is sent to the SCB.

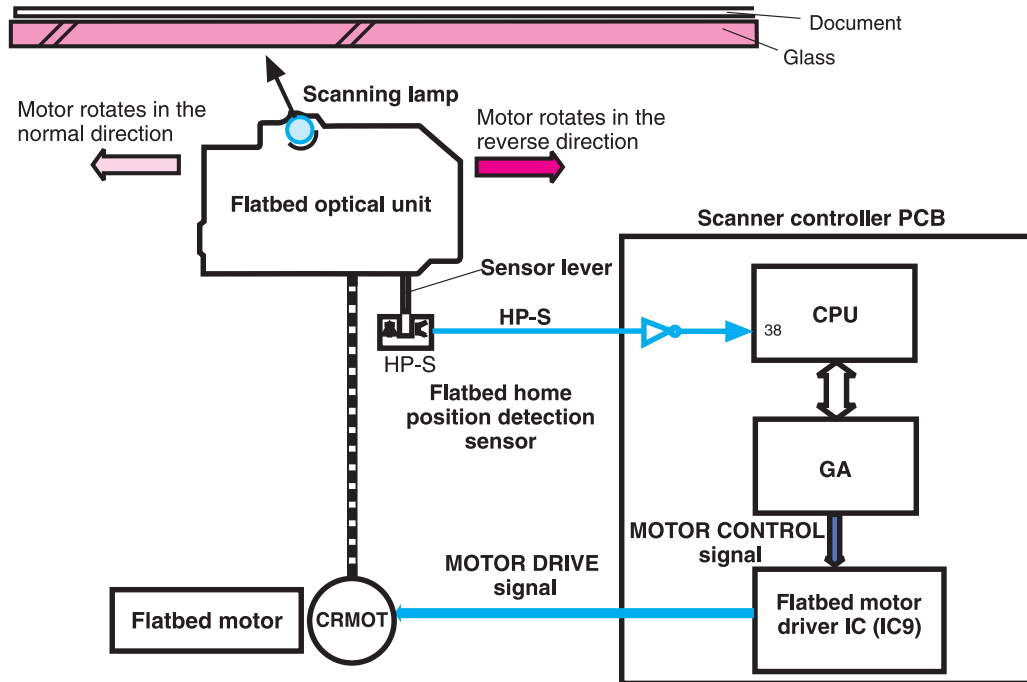


Figure 41. Flatbed optical drive control



## Flatbed document size detection

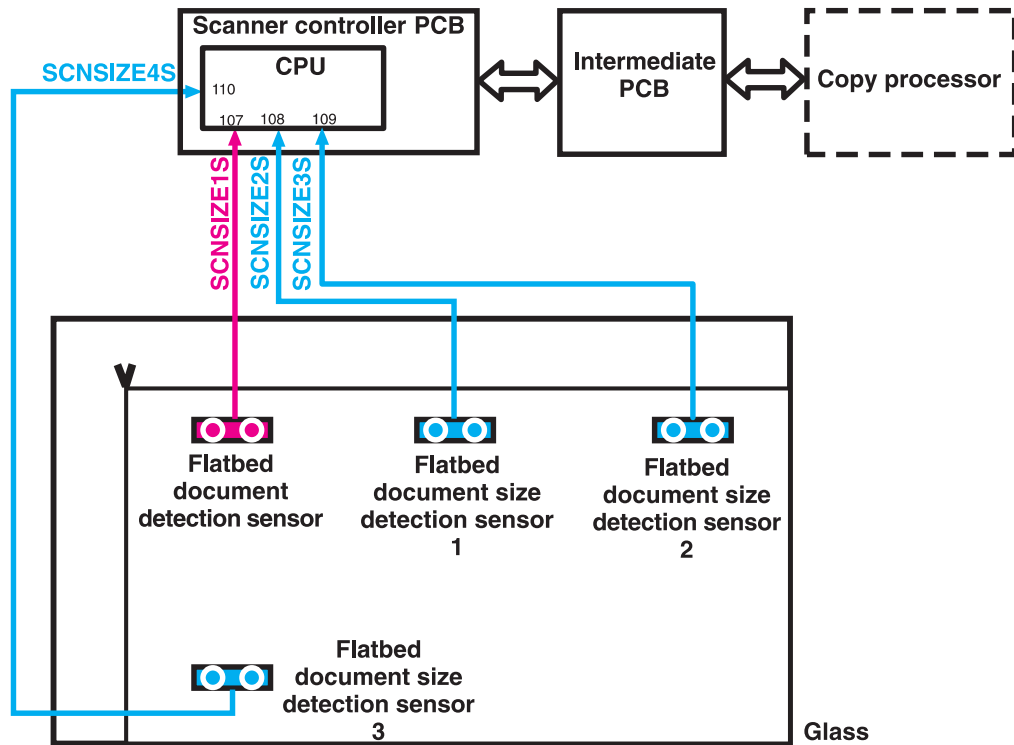


Figure 43. Flatbed document size detection

### Sensor names

- Flatbed document detection sensor: SCNSIZE1S (only detects the document on the glass)
- Flatbed document size detection sensor (1): SCNSIZE2S size sensor
- Flatbed document size detection sensor (2): SCNSIZE3S size sensor
- Flatbed document size detection sensor (3): SCNSIZE4S size sensor

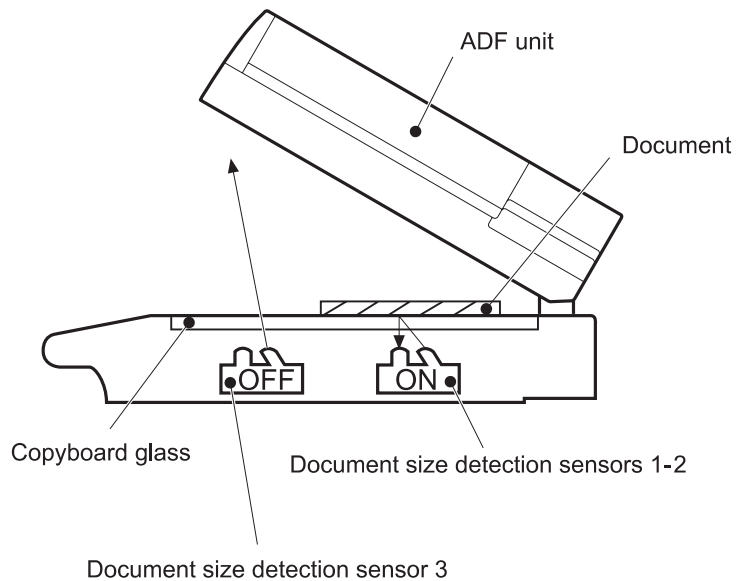
The sensors send signals to the SCB. The signals are transferred through the intermediate PCB to the CP. The CP calculates the size of the document based on the signals from the sensors.

The flatbed document sensors are located in the same positions on the 110 vdc and 220 vdc MFPs. To determine sizes of larger documents, the MFP searches the Cold Reset Paper Size. For example, it will detect ledger if it is set to letter, and it will detect A3 if it is set to A4.

## Functions operation

When a document is placed on the glass and the ADF unit is closed or at an angle of less than 30 degrees, the SCB begins to detect the presence and size of the document. The SCB monitors outputs from the flatbed document detection sensor (SCNSIZE1S) and the flatbed document size detection sensors (SCNSIZE2S, SCNSIZE3S, and SCNSIZE4S). The SCB passes the signals from the sensors to the CP.

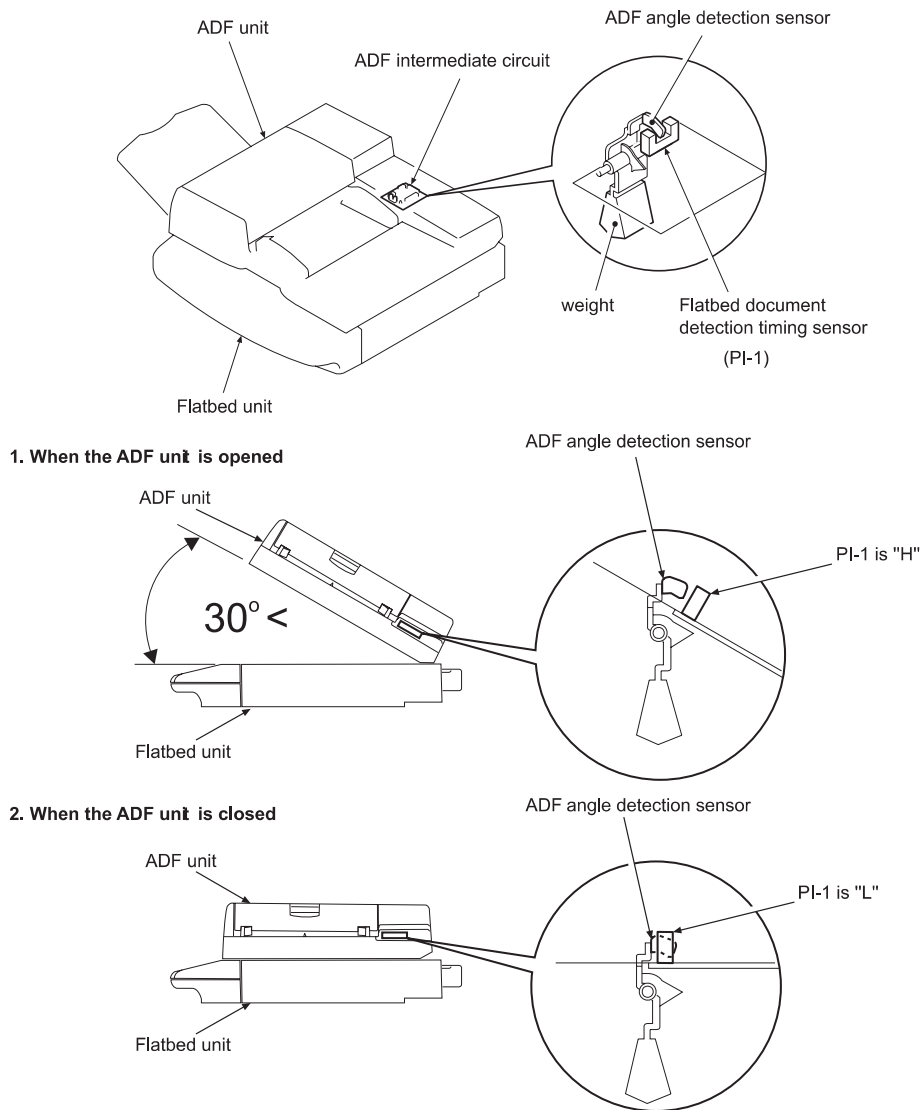
The reflecting sensor detects the presence and size information of the document based on whether the photoreceptor can receive the emitted light from the luminous body of the sensor. When a document is on the glass, the document reflects the emitted light and the photoreceptor can receive the reflected light. When there is not a document on the glass, the emitted light passes through the glass and the photoreceptor cannot receive the emitted light.



**Figure 44.** Functions operation

## ADF angle detection

The SCB performs the detection by monitoring an output of the ADF angle detection sensor (PI-1). The output of the PI-1 is "H" when the ADF unit is opened. When the angle between the glass and the ADF is less than 30 degrees, the sensor lever interrupts the PI-1 and the output of the PI-1 is "L."



**Figure 45.** ADF angle detection

## ADF operation

### ADF document exposure control

- 1 The SCB sends a signal to the ADF inverter to turn on the scanning lamp.
- 2 The ADF intermediate PCB and ADF analog processor board pass the signal through.
- 3 The ADF inverter sends the signal to the scanning lamp and the document exposure process begins.

#### Note

The ADF inverter, ADF analog processor, and the ADF intermediate PCB are located inside the ADF.

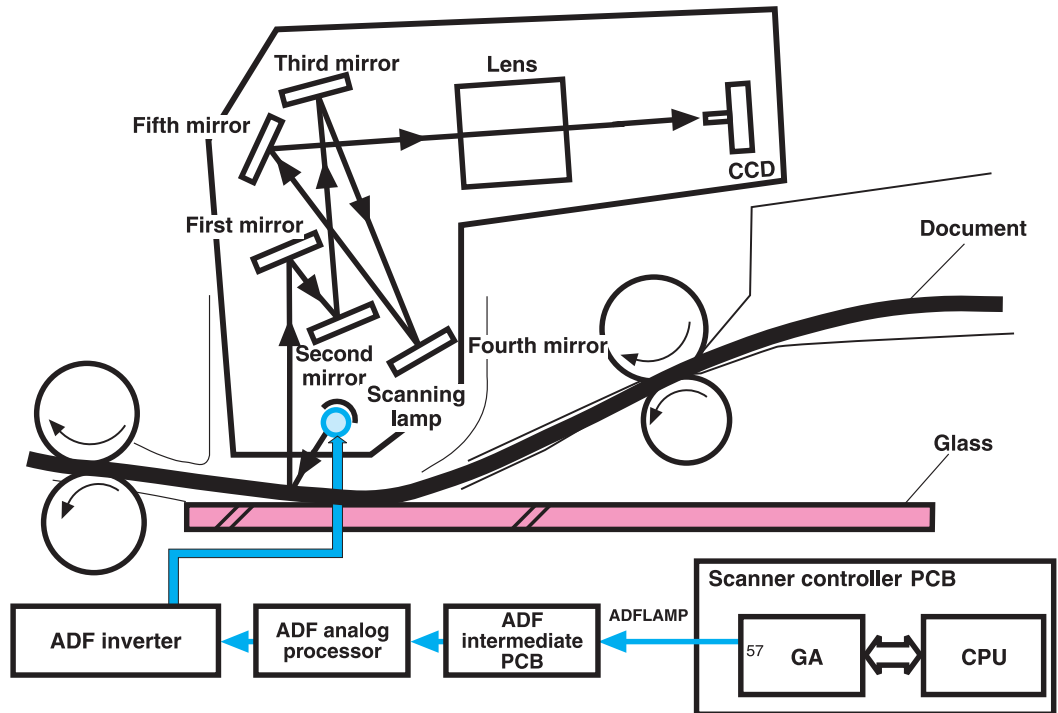


Figure 46. ADF document exposure control

## ADF document feed control

ADF document feed control is performed to pass paper over the optical units for exposure. The ADF document feed control process begins when the SCB sends signals. The shutter solenoid helps to align the paper, and the weight plate “slaps” down on the stack of paper.

### Note

Both the shutter solenoid and the weight plate help to perform the pickup process.

The pickup motor drives the pickup rollers and the feed rollers, and then reverses rotation to drive the registration rollers.

### ADF document feed control terminology

- STSOL: shutter solenoid
- PMOT: pickup motor
- WTSOL: weight solenoid
- DMOT: delivery motor

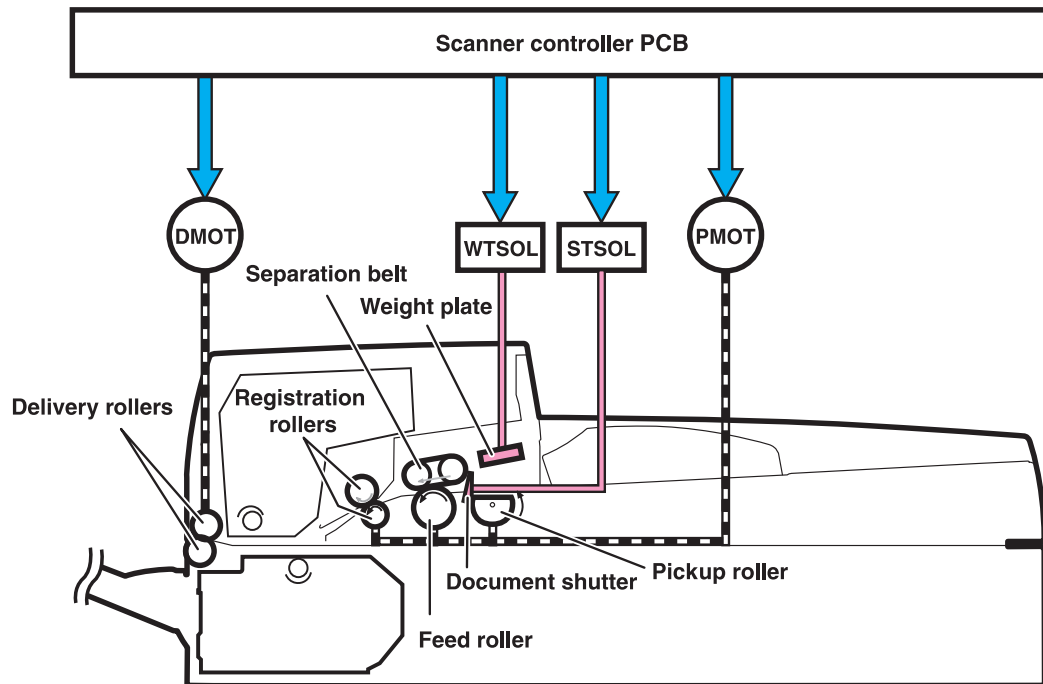


Figure 47. ADF document feed control

## Pickup and feed operation

- 1 The shutter solenoid is turned on when the SCB receives a scan command, and the document shutters drop.
- 2 About 200 milliseconds after the shutter solenoid is turned on, the pickup motor rotates in the normal direction. The pickup roller, feed roller, and separation belts begin to rotate. At the same time, the weight solenoid is turned on and the weight plate drops down. This allows the document on the document tray to be sent to the feed roller by receiving the rotation drive from the pickup roller and being pressed by the weight plate.
- 3 The document sent to the feed roller is sent to the ADF feeder after any multiple feeds are cleared by the feed roller and separation belts being driven by the pickup motor.
- 4 The document sent to the ADF feeder passes through the registration document detection sensor (REG-S) and reaches the registration roller. At this time the registration roller is not rotating so that the leading edge of the document is pushed against the registration roller to correct a skew.
- 5 After a set period of time from when the leading edge of the document passes the REG-S, the pickup motor rotates in its reverse direction. This allows the registration roller to start rotating and it re-feeds the document.
- 6 When the leading edge of the re-fed document reaches the timing detection sensor (TMG-S), the document scanning operation starts after a set period of time. The document set to the delivery roller is sent out of the scan engine by the delivery motor rotating in the normal direction. The delivery motor stops rotating after a set period of time.
- 7 When the delivery motor stops, the shutter solenoid is turned off. The pickup operation is complete after the pickup roller home position control operation.

## Pickup roller home position control operation

The pickup roller home position control operation sets the pickup roller at its home position as an advance preparation to allow the roller to pick up the document.

- 1 The SCB monitors the pickup home position detection sensor (PICK-S) to detect the home position.
- 2 At the initial operation, or after delivering the document, the SCB rotates the pickup motor in the reverse direction and checks a signal from the PICK-S.
- 3 When the PICK-S detects the pickup home position lever on the shaft of the pickup roller, the SCB determines that the pickup roller is at its home position and stops the pickup motor.
- 4 When the SCB cannot detect the home position of the pickup roller within a specified period of time after the pickup motor starts rotating in the normal direction, the SCB recognizes the pickup motor failure and notifies the CP. A 30.1.9 error is shown on the control panel.

## ADF document size detection

The sensors and the potentiometer send signals to the SCB, and these signals are transferred through the intermediate PCB to the CP. The CP calculates the size of the document based on the signals in the service menu.

### ADF document size detection terminology

- TRS-S: ADF document length detection (short)
- TRL-S: ADF document length detection (long)
- TRVR: ADF width detection unit (potentiometer)

#### Note

The width detection unit can be calibrated in the service menu.

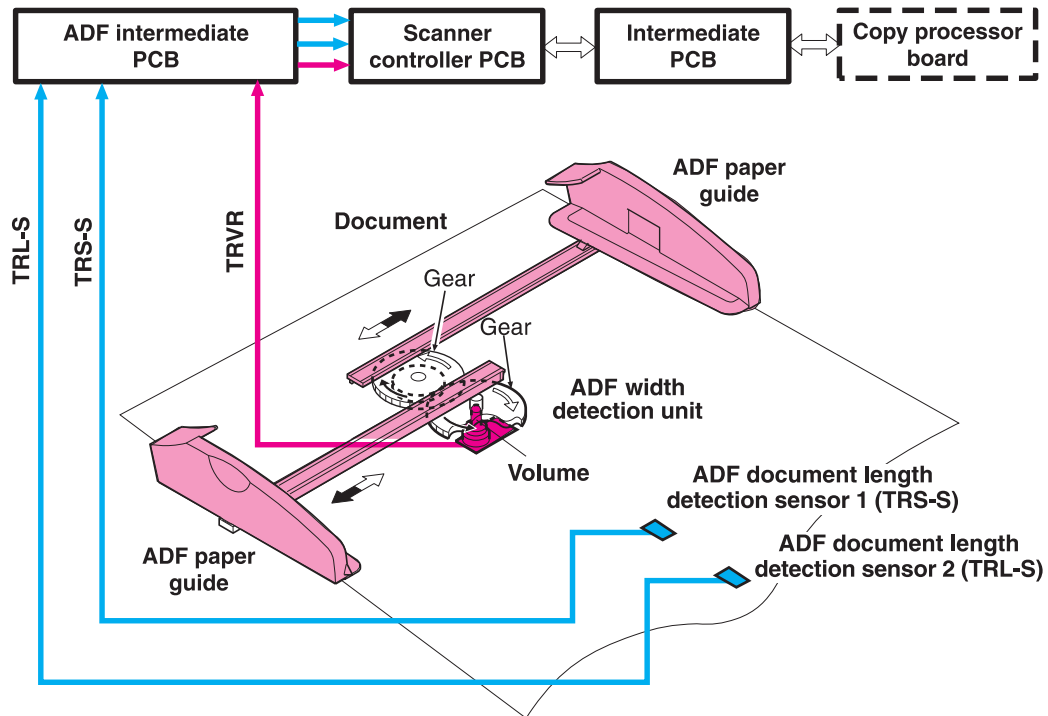


Figure 48. ADF document size detection

## ADF feeder sensors

- REG-S (registration sensor): detects when paper is approaching the registration rollers.
- TMG-S (timing sensor): verifies that paper is moving through the paper path.
- SKR-S (back skew sensor)
- SKF-S (front skew sensor)

### Note

The ADF has a document detection sensor that detects the presence of paper. This sensor is not shown in the graphic below. When the sensor detects the presence of paper, the LED on the ADF illuminates.

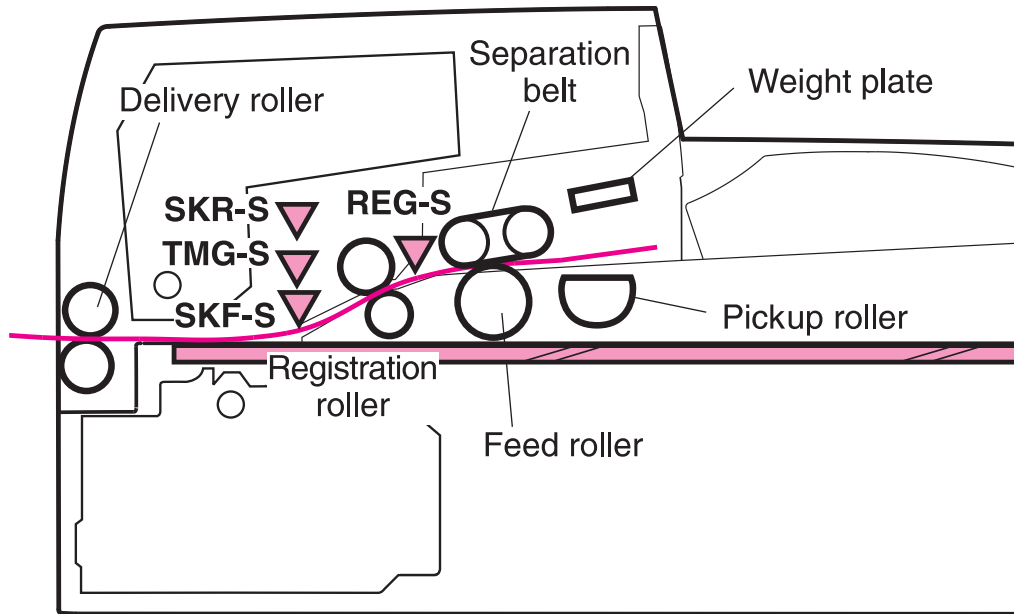


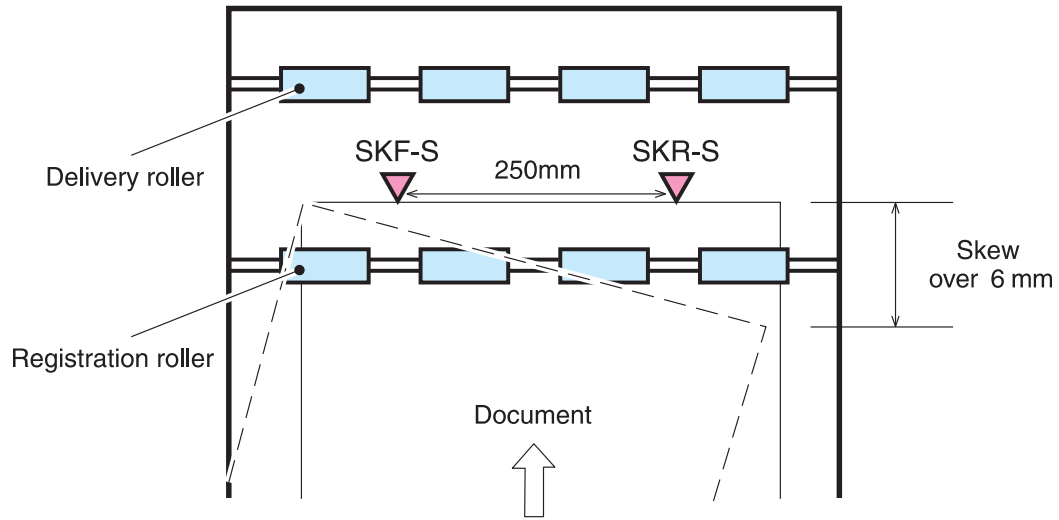
Figure 49. ADF feeder sensors

## ADF document skew detection

- 1 One of the skew sensors is activated.
- 2 A signal is sent to the SCB.
- 3 The SCB begins to read a certain number of clock pulses in 6 mm (.02 inch).
- 4 A skew jam is not reported if the second skew sensor is activated before the allotted number of pulses.

### Note

Skew detection is only performed when the document width is less than or equal to 257 mm (10.1 inches).



**Figure 50.** Document skew jam

## Scanned data flow

The MFP has a scan engine with 600 by 600 ppi (pixels per inch) resolution. It has three channels (red, blue, and green) with 10 bits per channel, resulting in the equivalent of a 30-bit scan engine.

Analog data is captured by the CCD driver circuit and converted to digital data on the analog processor board. Digital data is then sent through the three channels to the CP. The CP converts the digital data into one of the three final output types:

- HRB (hardware ready bits): most copy jobs are processed at the CP and sent to the print engine as HRB.
- PCL-XL: if rotation, book copying, or n-up is chosen in the job, the CP passes PCL-XL data to the print engine and the formatter finishes the processing.
- JPEG (lossless): compresses image data from the CP to the formatter when processing a digital send job. The formatter then processes the data into the desired file type (TIFF, MTIFF, JPEG, or PDF).

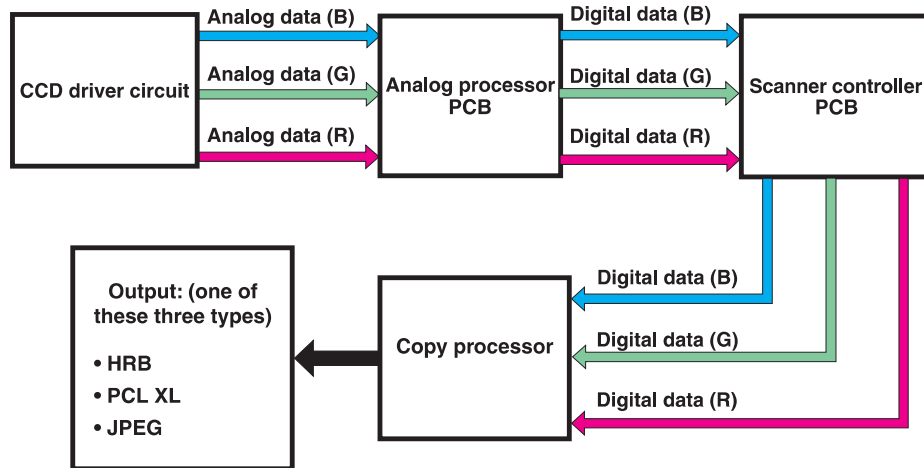


Figure 51. Scanned data flow

## Copy processor

The copy processor (CP) is the link between the formatter in the print engine and the SCB in the scan engine. Control signals from the formatter are sent to the CP. The CP sends these control signals to the SCB. After the scanning process is completed by the SCB, the scanned data is sent to the CP. The CP processes the image and sends the image data to the formatter.



**Figure 52.** Example of a copy processor (HP LJ 9000mfp/9000Lmfp shown)

## Scanning process control signals

The CP controls the following scanning process control signals:

- ADF unit and flatbed unit operation directs the SCB about the following:
  - when to scan
  - how to scan
  - when to activate motors
  - when to turn the scanning lamps on and off
- Image processing
  - color alignment
  - resolution conversion
  - image sharpening
  - moire removal
  - image scaling
  - shifting of data strips (reconstructing separately processed image data before CP communication to the formatter)
  - RGB conversion for CP communication
  - CP communication to the formatter using one of the following formats:
    - HRB (fastpath) communication with the hard drive on the formatter
    - PCL-XL (n-up, rotation, book mode) communication with the hard drive on the formatter
    - JPEG compression (when digitally sending data) communication with the hard drive on the formatter
  - data compression before sending to the formatter over the high speed copy connect cable

## Typical scanning process flow

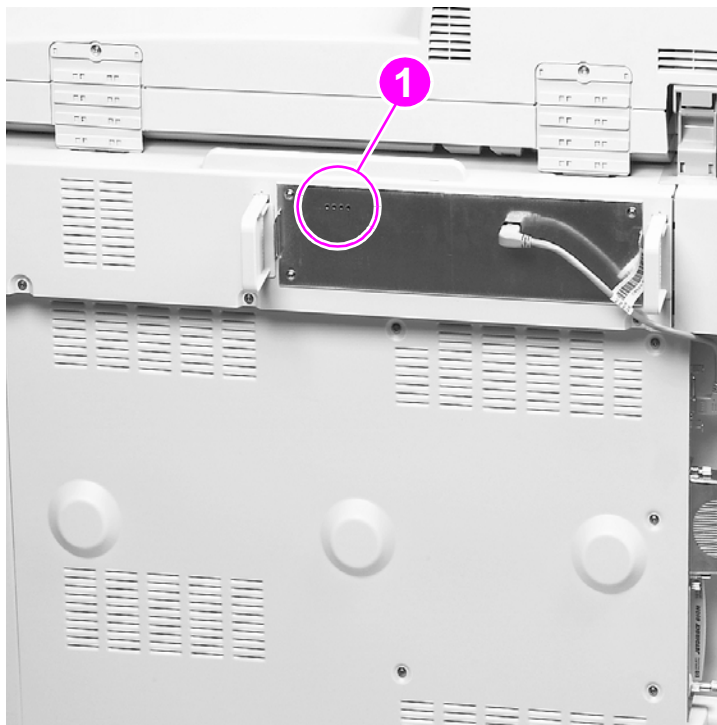
- 1 The original document is placed on the glass or in the ADF.
- 2 The user enters job preferences using the control panel keys. The user presses the **START** key. Job preferences are sent to the formatter.
- 3 Some job preferences, such as n-up, will be held and processed later by the formatter. Others are sent to the CP.
- 4 The CP sends control signals to the SCB. The document is scanned.
- 5 The SCB sends scanned image data back to the CP.
- 6 The CP processes the image.
- 7 The CP sends the image data to the formatter.
- 8 The formatter further processes the image data (if required).
- 9 The image data is then either printed or digitally sent depending on what the user specified at the beginning of the process.

## Copy processor LEDs (HP LJ 9000mfp/9000Lmfp)

The copy processor (CP) has four light-emitting diodes (LEDs) (callout 1) located at the back of the MFP. These LEDs illuminate in specific patterns depending on the status of the CP. The table in this section details what occurs at each stage of CP initialization.

**Hint** The LEDs can be difficult to see through the holes in the CP faceplate in a high-light environment. It may be necessary to turn off some lights or remove the faceplate to properly troubleshoot the LEDs.

The LED patterns displayed by the HP LaserJet 9000mfp are opposite those displayed by the HP LaserJet 4100/4101mfp because the CPs are mounted differently.



**Figure 53.** Copy processor LEDs (HP LJ 9000mfp/9000Lmfp)

**Table 53.** Copy processor LEDs (HP LJ 9000mfp/9000Lmfp)

LED pattern	CP status
<b>First stage of CP initialization</b>	
1 1 1* 1*	<ul style="list-style-type: none"> <li>Memory DIMM detected</li> <li>Firmware DIMM detected</li> <li>MIPS processor functional</li> <li>MIPS processor communicates with the ASIC</li> </ul>
* LEDs might flash before final continuous illumination	
<b>Note</b> If the LEDs stay in the illuminated state, a CP failure has occurred (for example, a memory DIMM is not present or fully seated).	
1 1 0 1	<ul style="list-style-type: none"> <li>The MIPS processor is communicating with the PCI Bridge</li> </ul>
0 1 0 1	<ul style="list-style-type: none"> <li>The MIPS processor is communicating with the FPGA</li> </ul>
0 0 0 1	<ul style="list-style-type: none"> <li>A check of the FPGA's SRAM is performed</li> </ul>

**Table 53. Copy processor LEDs (HP LJ 9000mfp/9000Lmfp) (continued)**

LED pattern	CP status
0 0 0 0	<ul style="list-style-type: none"><li>● CP is communicating with the DSP and DSP RAM</li></ul>
<b>Second stage of CP initialization</b>	
1 0 0 0	<ul style="list-style-type: none"><li>● The left-most LED illuminates and stays on when the connection to the SSA (the portion of the firmware that runs in the print engine RAM) is established.</li></ul>
1 1 0 0	<ul style="list-style-type: none"><li>● The second LED from the left illuminates when communication occurs between the CP and the scan engine.</li></ul>
1 1 0 1	<ul style="list-style-type: none"><li>● The right-most LED illuminates indicating the CP has booted properly. When this LED begins to flash (referred to as the CP heartbeat) the CP is functioning normally and the MFP is ready to process jobs.</li></ul>

## Copy processor LEDs (HP LJ 9040mfp/9050mfp/9500mfp)

The copy processor board (EIO) has two light-emitting diodes (LEDs) (LED 1 callout 1; LED 2 callout 2) located at the back of the MFP. These LEDs illuminate in specific patterns depending on the status of the copy processor board (EIO). The table in this section details what occurs at each stage of copy processor board (EIO) initialization.

### Hint

The LEDs are located on the engine portion of the MFP.



**Figure 54.** Copy processor LEDs (HP LJ 9040mfp/9050mfp/9500mfp)

**Table 54. Copy processor LEDs (HP LJ 9040mfp/9050mfp/9500mfp)**

LED 1	LED 2	Copy processor board (EIO) status
0	1	MFP power turned on. If LED 2 is does not illuminated, the copy processor board (EIO) is not seated correctly, or the copy processor board (EIO) or has failed.
1	1	The copy processor board (EIO) FPGA programming has started. If the copy processor board (EIO) does not processes past this stage, the copy processor board (EIO) has experienced a programming error, or the FPGA integrated circuit on the copy processor board (EIO) has failed.
0	1	The copy processor board (EIO) FPGA programming has finished. If the copy processor board (EIO) does not processes past this stage, the FPGA integrated circuit on the copy processor board (EIO) has failed.
1	1	The copy connect board assembly (in the scanner) FPGA programming has started. If the copy processor board (EIO) does not processes past this stage, check the wire harness connectors at the copy processor board (EIO) and the copy connect board assembly (in the scanner). Make sure the cable is not frayed, pinched, or broken. If the error persists, the FPGA integrated circuit on the copy connect board assembly (in the scanner) has failed.
0	1	The copy connect board assembly (in the scanner) FPGA programming has finished. If the copy processor board (EIO) does not processes past this stage, check the wire harness connectors at the copy processor board (EIO) and the copy connect board assembly (in the scanner). Make sure the cable is not frayed, pinched, or broken. If the error persists, the FPGA integrated circuit on the copy connect board assembly (in the scanner) has failed.

**Table 54. Copy processor LEDs (HP LJ 9040mfp/9050mfp/9500mfp) (continued)**

LED 1	LED 2	Copy processor board (EIO) status
0	0	The firmware is being downloaded and confirmed. If the copy processor board (EIO) does not processes past this stage, one or more of the following occurred. <ul style="list-style-type: none"><li>● the memory on the copy processor board (EIO) has failed</li><li>● the operating system did not start</li><li>● the copy processor board (EIO) is locked up</li></ul>
0	1	The operating system has successfully started and the copy processor board (EIO) application has started. If the copy processor board (EIO) does not processes past this stage, the copy processor board (EIO) is locked up, or the copy processor board (EIO) application failed to complete the startup processes.
0	0	The copy processor board (EIO) is initializing the scanner. LED 2 does not illuminate if there is communication between the formatter and the scanner fails, or if the fatal error in the scanner occurs.
0	1	The copy processor board (EIO) successfully established communication between the formatter and the scanner. If the copy processor board (EIO) does not processes past this stage, a problem exists with the Copy Send application (UI).
1	1	The copy processor board (EIO) successfully established communication with the Copy Send application (UI). If the copy processor board (EIO) does not processes past this stage, the copy processor board (EIO) heart beat signal did not start, or the signal is not being sent.
1,0,1,0 (blinking)	1	<ul style="list-style-type: none"><li>● LED 1 displays the copy processor board (EIO) LED heartbeat, indicating copy processor board (EIO) normal operation.</li><li>● If LED 1 stops in the off state, the copy processor board (EIO) application has failed.</li><li>● If LED 2 is off, a fatal error has occurred in the scanner, or the copy processor board (EIO) to scanner communication connection or the copy processor board (EIO) to formatter communication connection has failed,</li></ul>



# 7

# Troubleshooting

## Chapter contents

Troubleshooting process	245
Preliminary operating checks	246
Power on	247
Power-on defects	247
Malfunction troubleshooting	248
Troubleshooting with control panel messages	249
Control panel display	249
Event log page	249
Control panel messages	252
MFP message tables	253
Alphabetic error messages	253
Numeric error messages	255
Troubleshooting with the copy processor	260
HP LJ 9000mfp/9000Lmfp	260
HP LJ 9040mfp/9050mfp/9500mfp	262
User- and service-level diagnostics	264
Service test (HP LJ 9000mfp/9000Lmfp/9040mfp/9050mfp)	265
Service-level diagnostics	266
Service menu	266
Calibrations	268
Control-panel touch screen calibration (HP LJ 9000mfp/9000Lmfp)	268
Control-panel touch screen calibration (HP LJ 9040mfp/9050mfp/9500mfp)	270
Scanner/ADF calibration simplified	271
ADF calibrations	274
Glass calibrations	282
Plain motor speed calibration	285
Measurement and adjustment	287
ADF unit height adjustment	287
ADF skew adjustment	289
Weight solenoid stroke adjustment	292
Jam troubleshooting	293
Jams	293
Evaluating the information pages	295
Configuration page	295
Jetdirect page	297
Supplies status page	298
Usage page	299
File directory page	300

Image-formation troubleshooting .....	301
Copy-image defects .....	302
Scanner controller PCB .....	309
Connector locations .....	310
Electrical structure .....	311
Wiring diagrams .....	312

# Troubleshooting process

The troubleshooting process is a systematic approach that addresses the primary problems first, and then other problems, to discover the causes for MFP malfunctions and errors. An answer to a troubleshooting question allows troubleshooting to proceed to the next primary step.

Certain answers indicate that additional testing and correction is needed. Proceed to the appropriate section in this chapter and follow the directions. After completing the additional testing and correcting the problem, proceed to the next primary step.

This table describes the basic questions to answer and provides the corresponding troubleshooting sections that define the problem(s).

**Table 55. Primary steps for troubleshooting**

"Power on" on page 247	Does the MFP perform the initialization and power-on sequence?  This section contains the procedures for correcting power-supply problems.
"MFP message tables" on page 253	Does the control panel indicate an error condition?  This section contains the procedures for clearing control panel messages.
"Control panel menus (HP CLJ 9500mfp)" on page 59	Is it possible to perform a paper path test from the control-panel diagnostic menu?  This section contains information about how to troubleshoot paper-path and print-media problems.
"Evaluating the information pages" on page 295	Does information in the event log explain the problem?  This section contains the procedures for printing the information pages and evaluating and correcting MFP configuration.
"Image-formation troubleshooting" on page 301	Does the print quality meet customer expectations?  This section contains print-cartridge checks, information about EconoMode, image-defect examples, and the repeating-defect ruler.
"Measurement and adjustment" on page 287	Is the media in use acceptable for this MFP?  This section contains information about how to determine print-media problems and correct them.

## Preliminary operating checks

Make sure that the conditions in the following lists are met before troubleshooting a specific MFP problem.

### Installation environment:

- The MFP is plugged in, and specified power is delivered.
- Make sure that all cable connectors are fully seated.
- The MFP receives maintenance on a regular basis.
- The scan engine is securely installed on the print engine.
- The customer is using acceptable print media.
- The MFP is positioned on a solid, level surface.
- The line voltage does not vary more than 10 percent from the nominal rated value specified on the power rating label.
- The operating environment for the MFP is within the temperature and humidity specifications.
- The print engine is not exposed to ammonia fumes.
- The MFP is not exposed to direct sunlight.
- Non-HP components (such as refilled print cartridges, font DIMMs, and memory DIMMs) are removed from the MFP.

---

#### Note

Sudden changes in MFP environment can cause image defects and media-handling problems. Make sure the MFP is not exposed to direct sunlight or to heating or cooling vents. Allow time for the MFP and media to acclimate whenever changing environments (for example, moving from a cold environment to a warm one). Acclimation can take from 3 to 24 hours depending on the ambient conditions.

---

### Media checks

- The selected tray contains media that has been properly loaded and adjusted.
- The selected tray contains the correct amount of media.
- The recommended print media is in use.
- The document is not damp.
- The document is not dirty.

### Scanner/ADF checks

- Make sure the ADF feeder is closed.
- Make sure the ADF unit is closed.
- Make sure that the glass is clean

## Power on

It is important to have the MFP control panel functional as soon as possible in the troubleshooting process so that the MFP diagnostics can be used to assist in locating printing errors.

### Power-on defects

**Table 56. Power-on defects or blank display**

Problem	Action
Is ac power available at the print engine power receptacle?	Verify that power is available. See "Specifications" on page 23.
Is the MFP on/off switch set to the on position?	Push the switch to the "on" position.
Are the print engine fans on?	<p>Touch the display screen to put the MFP in the ready state.</p> <p><b>Note:</b> The fan operation is significant because all fans are controlled by the dc controller on the print engine. Fans 1 through 5 operate at full speed for 30 seconds during the WAIT period. Fans 1 through 4 will slow to half-speed, and fan 5 will stop during the STBY period and when the MFP is in PowerSave mode. Make sure that the MFP is not in PowerSave mode.</p> <p>Operational fans indicate the following:</p> <ol style="list-style-type: none"> <li>1 ac power is present in the print engine</li> <li>2 the dc power supply is functional (both 24 vdc and 5 vdc are being generated)</li> <li>3 the dc controller is functional</li> </ol>
NO	If the fans are NOT working, troubleshoot using the print engine service manual for your MFP model.
YES	If the test is successful, check the control panel cable connections at the back of the control panel and at the back of the print engine.

## Malfunction troubleshooting

If the malfunction is identified, use the following table for troubleshooting:

**Table 57. Malfunction troubleshooting**

Cause	Solution
<b>No ac power</b>	
Defective power supply assembly	<ul style="list-style-type: none"> <li>● Make sure that the wall receptacle has the appropriate voltage for the MFP.</li> <li>● If a power strip is being used, remove it and plug the MFP directly into the wall receptacle.</li> <li>● Make sure that the MFP is plugged into a dedicated circuit and that the circuit meets the recommended specifications. See See “Specifications” on page 23.</li> <li>● Make sure that the print engine power supply is functioning correctly.</li> <li>● Replace the power supply assembly.</li> </ul>
Defective remote function	<ul style="list-style-type: none"> <li>● Reconnect connectors J404 and J405 on the intermediate PCB, intermediate connector J171, and connector J206 on the dc controller on the print engine.</li> </ul>
<b>No dc power</b>	
No ac power is supplied	<ul style="list-style-type: none"> <li>● Check for ac power.</li> </ul>
The over-current/over-voltage detection circuit is activated	<ul style="list-style-type: none"> <li>● Turn off the MFP, wait approximately two minutes, and then turn it back on. If the problem persists, find the cause of the overcurrent/overvoltage detection circuit activation in the power supply assembly.</li> </ul>
Defective power supply assembly	<ul style="list-style-type: none"> <li>● Replace the power supply assembly.</li> </ul>
Defective wiring, dc loads, or scanner controller PCB	<ul style="list-style-type: none"> <li>● Turn off the power switch. Check the wiring ahead of the scanner controller PCB and the dc loads. If you discover the problem, replace the wiring and dc loads. If no problem exists on the wiring or dc loads, replace the scanner controller PCB.</li> </ul>

# Troubleshooting with control panel messages

## Control panel display

The control panel should show `READY`, `PAUSED`, or `POWERSAVE ON`. For information about error messages that appear, see the event log. If the control panel is blank, see “Power on” on page 247.

## Event log page

---

**Note**

---

The sample information pages in this section are from the HP LaserJet 9000mfp/9000Lmfp. Information pages printed from other MFPs will have some variation from these samples (for example the MFP name at the top of the page).

Use the event log to diagnose and troubleshoot MFP errors and intermittent failures. You can either print or show the event log from the control panel. (Select `PRINT EVENT LOG` or `SHOW EVENT LOG`.)

The event log is a last in-first out (LIFO) ordered listing of the last 50 entries. The printed event log is printed in four columns that show event number, page count, error code, and description or personality.

The description or personality gives detail to the error messages. The information is more useful for troubleshooting.

Items that should be logged in the event log include the following:

- critical errors
- jams
- sensors sensing out of range
- deleted jobs
- unexpected paper size
- complex pages
- buffer overflow
- NVRAM changes
- any diagnostics tests

## Print the event log

The MFP internal event log stores the 50 most recent events, and can be printed at any time. To print the event log:

- 1 Using the touch screen, touch `MENU` to open the menus.
- 2 Touch `DIAGNOSTICS`.
- 3 Touch `PRINT EVENT LOG`.
- 4 The event log prints. The control panel shows the message `PRINTING EVENT LOG`.

## Interpret the event log

Each individual entry in the log is called an “error,” while all errors occurring at the same page count are called an event. See page 146 for each error within an event and to better understand the event. Events usually conclude with a time-out or no response from the MFP (error 66.xx in the event log). Turn the MFP off, and then turn it back on.

Use the event log tables in this section to associate errors in the event log with the control panel error message. For each error or event, follow the recommended action listed in the event log table starting on page 253.

- 1 Check the event log for specific error trends in the last 10,000 printed pages.
- 2 Ask the customer for any observed error trends. (For example, do jams tend to occur in a specific area of the MFP?)
- 3 Record any specific error trends.
- 4 See “MFP message tables” on page 253 and follow the recommended actions.

**HP LaserJet 9000 series printers**

hp  
invent

Event Log Page 1

Current Page Count: 4      Serial Number: XXXXXXXXXX

Number	Error	Page Count	Description or Personality
2	55 0492	0	
1	55 0000	0	?? PRINTER ERROR CYCLE POWER TO CONTINUE

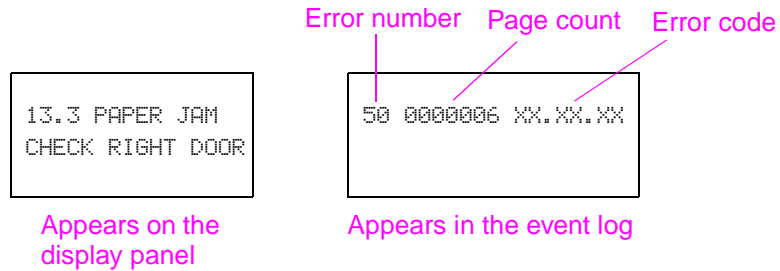
**Figure 202.** Sample event log page (HP LJ 9000mfp/9000Lmfp shown)

## Show the event log

Using the displayed event log, the customer can scroll through the contents of the event log from the control panel. Select this to show the 50 most recent events, with the most recent first. Use ▲ or ▼ to scroll through the event log contents. If the event log is empty, the control panel shows the message `EVENT LOG IS EMPTY`.

Follow these steps to show the event log:

- 1 Using the touch screen, touch `MENU` to open the menus.
- 2 Touch `DIAGNOSTICS`.
- 3 Touch `SHOW EVENT LOG`.
- 4 The event log appears.



**Figure 203.** Example of events on the event log

---

### Hint

Whenever a `13.xx` message appears on the control panel, a good practice is to clear the jammed paper from the MFP, press **STOP** to stop printing, and print the event log. Even if you cannot print the event log, you can read it on the control panel.

---

## Control panel messages

Be sure to read the exact text of the control panel message, including the error message number and the text, in order to locate the error message in the tables.

Messages that appear on the control panel provide six categories of information. Each message category is assigned a priority. If more than one condition occurs at the same time, the highest priority message appears. When it has been cleared, the next priority message appears, and so on. The messages and their priorities are:

- **Status messages**—Status messages communicate the current state of the MFP to the user. Whenever the MFP is ready and online, the MFP status message `READY` appears unless warning messages are pending. When the MFP is performing a task, such as a reset or a test, the associated MFP status message appears. When the task is complete, the message returns to `READY`, depending on the current state of the MFP.
- **Warning messages**—Warning messages are messages that are important enough that the user must acknowledge them, but not serious enough to cause the MFP to stop the printing process. They are usually transient in nature but they can affect the output, and so a record of their occurrence is important. Warnings generally alternate with the `READY` status message and remain on the control panel until the user touches Continue or presses Stop. Warnings appear in most recent order (LIFO) with duplicates removed.
- **Error messages**—Error messages communicate to the user that some action must be performed, such as adding paper or clearing a jam. Some errors are considered auto-continuable, because the error message appears on the control panel for 10 seconds, and then the MFP clears the message and continues normal operation. Pressing a control panel key during the 10-second period cancels the auto-continue feature and initiates the function of the key that was pressed. Error messages are limited to 19 seven-bit characters (or 9 two-byte characters) per line up, and to two lines. Unlike status and warning messages, error messages stop the printing process. The user has to either fix the problem or give the MFP a different command. If the error message is a scan engine error (30.x.xx), then the user cannot copy and scan, but can continue to print. If the user can continue past the error conditions without actually fixing the problem, then the user should be able to perform the task by touching Continue. If only one option is available when the user touches Continue, printing should continue by applying the option shown. If more than one option is available, the options are listed with the most logical option listed first and highlighted.
- **Critical error messages**—Critical error messages communicate MFP failures to the user. Generally, turning power off and then on is required in order for the MFP to resume normal operation. If the critical error persists, then the MFP probably requires maintenance and the user will have to request a service call. Critical errors are not auto-continuable.
- **Finishing device warning messages**—These messages are similar to the warning messages described above, except that they relate to the finishing device. By default, the message is all that appears if the finishing device does not provide any additional help. The prompt at the bottom of the control panel does not appear.
- **Finishing device error messages**—These messages are similar to the error messages described above, except that they relate to the finishing device. By default, the message is all that appears if the finishing device does not provide any additional help. The prompt at the bottom of the control panel does not appear. See the *Paper Handling Accessories Addendum* (Q5693-90002).

---

### Note

Print a configuration page to identify the input or finishing device that is configured. Notice that the error format only identifies the Jet-Link device number and the device type; it does not identify the input or finishing device.

## MFP message tables

Messages appear on the control panel to indicate MFP operation errors. Within the groupings listed below, the alphabetic error messages are listed first, followed by the numeric error messages.

### Alphabetic error messages

**Table 58. Alphabetic error messages**

Message	Event log display	Explanation	Recommended action
ADF COVER OPEN		The ADF feeder is open or the ADF feeder switch is not functioning correctly.	<ol style="list-style-type: none"> <li>1. Close the ADF feeder.</li> <li>2. If the error persists, perform a <b>SENSORS</b> diagnostic in the diagnostics menu to test the ADF feeder switch.</li> </ol>
ADF PAPER JAM		A page has jammed inside the ADF feeder and must be cleared before copying can continue.	<ol style="list-style-type: none"> <li>1. Open the ADF feeder and remove the jammed media. Close the ADF feeder.</li> <li>2. Reload the document and press <b>START</b>.</li> <li>3. If the error persists, perform an <b>ADF INPUT</b>, <b>ADF INPUT REVERSE</b>, and <b>ADF OUTPUT</b> diagnostic in the diagnostics menu to verify proper functionality of the ADF feeder rollers.</li> <li>3. Verify that the pickup roller, feed roller assembly, separation belt assembly, and registration roller assemblies are clean and not damaged.</li> </ol>
ADF PICK ERROR		Too many pages have been placed in the ADF or the pages are not correctly paced in the ADF feeder. The pickup roller might be dirty, damaged, or not installed correctly.	<ol style="list-style-type: none"> <li>1. Remove some of the pages and try the operation again. If necessary, open the ADF feeder and remove any jammed media, and then close the ADF feeder.</li> <li>2. Perform an <b>ADF INPUT</b> diagnostic in the diagnostics menu to verify that the pickup roller is functioning correctly.</li> <li>3. Perform a <b>WEIGHT SOLENOID</b> diagnostic in the diagnostics menu to verify the weight arm is functioning correctly.</li> <li>4. Verify that the pickup roller is clean and not damaged.</li> </ol>

**Table 58. Alphabetic error messages (continued)**

Message	Event log display	Explanation	Recommended action
ADF SKEW ERROR	30.01.11	A skew in the ADF feeder has been detected by the ADF skew sensors.	<ol style="list-style-type: none"> <li>1. Open the ADF feeder and remove the skewed media. Close the ADF feeder.</li> <li>2. Reload the document and press START.</li> <li>3. If the error persists, perform a <b>SENSORS</b> diagnostic in the diagnostics menu to verify that the skew front and skew back sensors are functioning correctly.</li> <li>4. Verify that J112 on the scanner control board, J701 and J704 on the ADF intermediate PCB, and J801 on the ADF sensor PCB are fully seated.</li> <li>5. Verify that the pickup roller, feed roller assembly, separation belt assembly, and registration roller assemblies are clean and not damaged.</li> </ol>
FLATBED COVER OPEN		The ADF is open or the ADF open/closed sensor is not functioning correctly.	<ol style="list-style-type: none"> <li>1. Close the ADF.</li> <li>2. If the error persists, perform a <b>SENSORS</b> diagnostic in the diagnostics menu to test the ADF open/closed sensor.</li> </ol>
RESEND UPGRADE		Power to the MFP was lost during a firmware upgrade	<ol style="list-style-type: none"> <li>1. Start the firmware upgrade operation over.</li> </ol>

# Numeric error messages

**Table 59. Numeric error messages**

Message	Event log display	Explanation	Recommended action
30.0.01 SCANNER I/O FAILURE CHECK CABLES AND CYCLE POWER		Communication between the formatter and the copy processor board has failed.	<ol style="list-style-type: none"> <li>1. Verify that the high-speed copy connect cable between the copy connect card and the copy processor board is correctly connected. Verify that the copy processor board is firmly seated into the connector on the intermediate PCB.</li> <li>3. Check for broken, frayed, or pinched wires.</li> <li>4. Verify that the copy processor board LEDs are illuminated.</li> </ol>
30.0.02 SCANNER I/O FAILURE CHECK COPY CONNECT CARD		The IEEE-1394 copy connect card is not detected.	Refer to the steps in this table for clearing the scanner I/O failure.
30.1.06 SCAN FAILURE		Flatbed fan failure.	<ol style="list-style-type: none"> <li>1. With the MFP powered on, verify that the fan is not functioning.</li> <li>2. Check for loose connections and broken, frayed, or pinched wires. Reseat the fan connector at scanner control PCB location J110, and connector J163 on the flatbed fan.</li> <li>3. Replace the fan. See "Flatbed fan assembly" on page 206.</li> </ol>
30.1.02 ADF PAPER JAM		A jam has occurred in the ADF.	<ol style="list-style-type: none"> <li>1. Open the ADF feeder and remove the jammed media. Close the ADF feeder.</li> <li>2. Reload the document and press START.</li> <li>3. If the error persists, perform a SENSORS diagnostic in the diagnostics menu to verify that the skew front and skew back sensors are functioning correctly.</li> <li>4. Verify that the pickup roller, feed roller assembly, separation belt assembly, and registration roller assemblies are clean and not damaged.</li> </ol>
30.1.07 SCAN FAILURE		Communication error.	<ol style="list-style-type: none"> <li>1. Print a configuration page to verify that the CPB firmware is loaded.</li> <li>2. Turn the power off, unplug the power cord. Plug in the power cord, and turn the power on.</li> </ol>

**Table 59. Numeric error messages (continued)**

Message	Event log display	Explanation	Recommended action
30.1.08 SCAN FAILURE		Flatbed motor failure.	<ol style="list-style-type: none"> <li>1. Perform a FLATBED MOTOR diagnostic in the diagnostics menu to verify that the flatbed motor is functioning correctly.</li> <li>2. Check for loose connections and broken, frayed, or pinched wires.</li> <li>3. Reseat the flatbed motor connector at the SCB location J108.</li> <li>4. Replace the flatbed motor.</li> </ol>
30.1.09 SCAN FAILURE		The pickup roller home position sensor is not detecting the pickup roller home position.	<ol style="list-style-type: none"> <li>1. Perform an ADF INPUT diagnostic in the diagnostics menu to verify that the pickup roller assembly is functioning correctly.</li> <li>2. Check for loose connections and broken, frayed, or pinched wires.</li> <li>3. Reseat connector J112 on the SCB, connectors J701 and J703 on the ADF intermediate PCB, and connector J716 on the pickup roller home position detection sensor.</li> <li>4. Check the pickup roller home position detection sensor and the pickup roller assembly for disengagement or damage.</li> <li>5. Replace the SCB.</li> </ol>
30.1.10 SCAN FAILURE		ADF fan error.	<ol style="list-style-type: none"> <li>1. With the MFP powered on, verify that the fan is not functioning.</li> <li>2. Check for loose connections and broken, frayed, or pinched wires.</li> <li>3. Reseat the fan connector at scanner control PCB location J109, and connector J156 on the ADF fan.</li> <li>4. Replace the ADF fan.</li> <li>5. Replace the SCB.</li> </ol>

**Table 59. Numeric error messages (continued)**

Message	Event log display	Explanation	Recommended action
<p>30.01.11 ADF SKEW ERROR</p>		<p>A skew in the ADF feeder has been detected by the ADF skew sensors.</p>	<ol style="list-style-type: none"> <li>1. Open the ADF feeder and remove the skewed media. Close the ADF feeder.</li> <li>2. Reload the document and press <b>START</b>.</li> <li>3. If the error persists, perform a <b>SENSORS</b> diagnostic in the diagnostics menu to verify that the skew front and skew back sensors are functioning correctly.</li> <li>4. Verify that J112 on the scanner control board, J701 and J704 on the ADF intermediate PCB, and J801 on the ADF sensor PCB are fully seated.</li> <li>5. Verify that the pickup roller, feed roller assembly, separation belt assembly, and registration roller assemblies are clean and not damaged.</li> </ol>
<p>30.1.12 SCAN FAILURE</p>		<p>ADF ASIC error.</p>	<ol style="list-style-type: none"> <li>1. Turn the power off, unplug the power cord. Plug in the power cord, and turn the power on.</li> <li>2. Reconnect connectors J158 and J159 on the ADF inverter PCB, and reconnect connector J104 on the SCB.</li> <li>3. Reconnect connector J102 on the ADF inverter PCB, connectors J301 and J304 on the ADF analog processor board, and J601 on the ADF CCD driver PCB.</li> <li>4. Reconnect connector J303 on the ADF analog processor PCB, and connector J602 on the ADF CCD driver PCB.</li> <li>5. Replace the ADF inverter PCB (LJ 9000mfp/9000Lmfp only).</li> <li>6. Replace the ADF lamp assembly (LJ 9000mfp/9000Lmfp only).</li> <li>7. Replace the ADF analog processor PCB.</li> <li>8. Replace the SCB.</li> <li>9. Replace the ADF optical assembly.</li> </ol>

**Table 59. Numeric error messages (continued)**

Message	Event log display	Explanation	Recommended action
30.1.13 SCAN FAILURE		Scanner ASIC error.	<ol style="list-style-type: none"> <li>1. Turn the power off, unplug the power cord. Plug in the power cord, and turn the power on.</li> <li>2. Reconnect connector J161 and J162 on the flatbed inverter PCB, and connector J205 on the SCB.</li> <li>3. Reconnect connector J103 on the SCB, J504 and J503 on the flatbed intermediate PCB, J201 and J202 on the flatbed analog processor PCB, and J601 on the flatbed CCD driver PCB.</li> <li>4. Reconnect connector J105 on the SCB, J502 and J501 on the flatbed intermediate PCB, J203 and J204 on the flatbed analog processor PCB, and J602 on the flatbed CCD driver PCB.</li> <li>5. Replace the flatbed inverter PCB (LJ 9000mfp/9000Lmfp only).</li> <li>6. Replace the flatbed lamp assembly (LJ 9000mfp/9000Lmfp only).</li> <li>7. Replace the SCB.</li> <li>8. Replace the flatbed optical assembly.</li> </ol>
30.1.14 SCAN FAILURE		EEPROM error.	Replace the SCB.
30.1.15 SCAN FAILURE		A condition has prevented the scan engine from initializing.	<ol style="list-style-type: none"> <li>1. Verify that all covers are installed correctly and that the ADF and ADF feeder are closed.</li> <li>2. Turn the power off, and then on.</li> <li>3. If the error persists, perform a <b>SENSORS</b> diagnostic in the diagnostics menu to verify that all of the sensors are functioning correctly.</li> <li>4. Check the LED status on the CP. Follow the CP troubleshooting instructions if the LEDs are not in the ready status.</li> </ol>
30.1.16 SCAN FAILURE		Incorrect ADF width sensor values.	Perform an <b>ADF WIDTH SENSOR</b> calibration.
30.1.20 SCAN FAILURE		CP processing error.	Turn the power off, unplug the power cord. Plug in the power cord, and turn the power on.
30.1.21 SCAN FAILURE		CP processing error.	Turn the power off, unplug the power cord. Plug in the power cord, and turn the power on.
30.1.22 SCAN FAILURE		CP processing error.	Turn the power off, unplug the power cord. Plug in the power cord, and turn the power on.

**Table 59. Numeric error messages (continued)**

<b>Message</b>	<b>Event log display</b>	<b>Explanation</b>	<b>Recommended action</b>
30.1.25 SCAN FAILURE		CP processing error.	1. Turn the power off, unplug the power cord. Plug in the power cord, and turn the power on. 2. Replace the SCB.

## Troubleshooting with the copy processor

### HP LJ 9000mfp/9000Lmfp

The table in this section is a quick-reference source for troubleshooting common copy processor board (CP) failures that might occur. The LED pattern column describes the status of the four LEDs located on the back of the MFP. The control panel display column lists the messages appearing on the control panel display when a failure occurs. The MFP functionality column describes what MFP functions are affected by the CP failure. The action column lists the appropriate troubleshooting steps.

To troubleshoot the CP using the LEDs, verify which LEDs are illuminated and those that are not. Check for messages appearing on the control panel display, and press **OK**. Match the LED pattern to the examples found in table 60 and perform the procedure found in the action column of the table.

---

#### Note

For information about CP initialization LED patterns and their meanings, see “Copy processor LEDs (HP LJ 9000mfp/9000Lmfp)” in chapter 5.

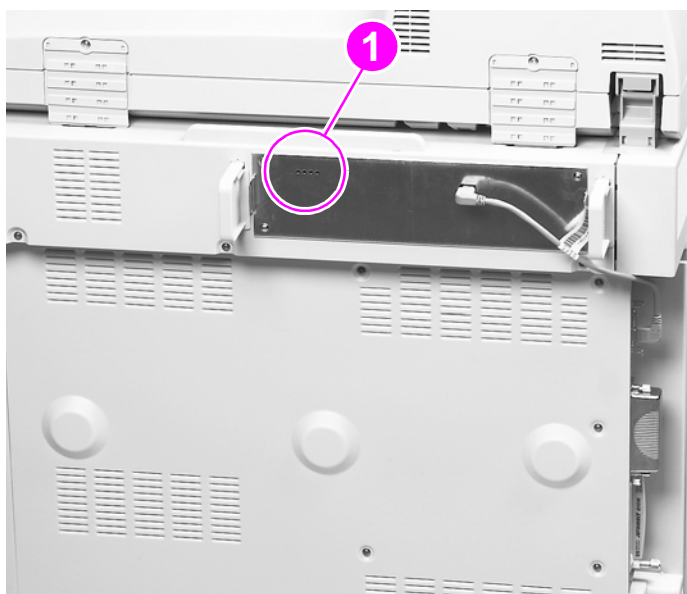
The print engine and scan engine have separate power supplies. The control panel is powered by the power supply in the print engine. The CP is powered by the power supply in the scan engine.

---

#### Hint

The LEDs can be difficult to see through the holes (callout 1) in the CP face-plate in a high-light environment. It might be necessary to turn off some lights or remove the face-plate to properly troubleshoot the LEDs.

---



**Figure 204.** Copy processor board LEDs

When troubleshooting the copy processor board LEDs, remember that the:

- Scan engine power supply is powered by the print engine power supply.
- Control panel is powered by the print engine power supply.
- CP is powered by the scan engine power supply.

**Table 60. Troubleshooting copy processor board LEDs**

LED pattern (HP LaserJet 9000mfp/9000Lmfp)	Control panel display	MFP functionality	Action
1 1 1 1 0 0 0 1 0 1 0 0 1 1 0 1 1 1 0 1*  *Flashing	READY	<ul style="list-style-type: none"> <li>● Print - yes</li> <li>● Copy - yes</li> <li>● Send - yes</li> </ul>	Normal, ready state and the CP is functioning properly. No troubleshooting is necessary.
1 1 1 1 0 0 0 1 0 1 0 0 1 1 0 1 0 1 0 1*  *Flashing	CHECK CABLES AND CYCLE POWER	Select OK, then attempt to: <ul style="list-style-type: none"> <li>● Print - yes</li> <li>● Copy - no</li> <li>● Send - no</li> </ul>	<ol style="list-style-type: none"> <li>1. Verify that the high-speed copy connect cable is fully seated at both ends.</li> <li>2. Turn the MFP power off, and then back on again.</li> <li>3. Replace the high-speed copy connect cable.</li> <li>4. Replace the CPB.</li> </ol>
1 1 1 1 0 0 0 1 0 1 0 0	CHECK CABLES AND CYCLE POWER	Select OK, then attempt to: <ul style="list-style-type: none"> <li>● Print - yes</li> <li>● Copy - no</li> <li>● Send - no</li> </ul>	<ol style="list-style-type: none"> <li>1. Verify that the high-speed copy connect cable is fully seated at both ends.</li> <li>2. Turn the MFP power off, and then back on again.</li> <li>3. Replace the high-speed copy connect cable.</li> </ol>
1 1 1 1*  *Flashing	CHECK CABLES AND CYCLE POWER	Select OK, then attempt to: <ul style="list-style-type: none"> <li>● Print - yes</li> <li>● Copy - no</li> <li>● Send - no</li> </ul>	<ol style="list-style-type: none"> <li>1. Reseat the firmware DIMM.</li> <li>2. Turn the MFP power off, and then back on again.</li> </ol>
1 1 1 1*  *Dimly lit	CHECK CABLES AND CYCLE POWER	Select OK, then attempt to: <ul style="list-style-type: none"> <li>● Print - yes</li> <li>● Copy - no</li> <li>● Send - no</li> </ul>	<ol style="list-style-type: none"> <li>1. Redownload the firmware,</li> <li>2. Replace the firmware DIMM.</li> </ol>
1 1 1 1	CHECK CABLES AND CYCLE POWER	Select OK, then attempt to: <ul style="list-style-type: none"> <li>● Print - yes</li> <li>● Copy - no</li> <li>● Send - no</li> </ul>	<ol style="list-style-type: none"> <li>1. Reseat the memory DIMM.</li> <li>2. Verify that the DIMM is 32 MB.</li> <li>3. Replace the memory DIMM.</li> </ol>
0 0 0 0	CHECK CABLES AND CYCLE POWER	Select OK, then attempt to: <ul style="list-style-type: none"> <li>● Print - yes</li> <li>● Copy - no</li> <li>● Send - no</li> </ul>	<ol style="list-style-type: none"> <li>1. Reseat the CP.</li> <li>2. Turn the MFP power off, and then back on again.</li> </ol>
1 1 1 1 0 0 0 1 0 1 0 0	CHECK COPY CONNECT CARD	Select OK, then attempt to: <ul style="list-style-type: none"> <li>● Print - yes</li> <li>● Copy - no</li> <li>● Send - no</li> </ul>	<ol style="list-style-type: none"> <li>1. Reseat the copy connect card.</li> <li>2. Turn the MFP power off, and then back on again.</li> </ol>

**Note**

If the CP failure persists after all attempts to troubleshoot the problem, replace the CP.

**Hint**

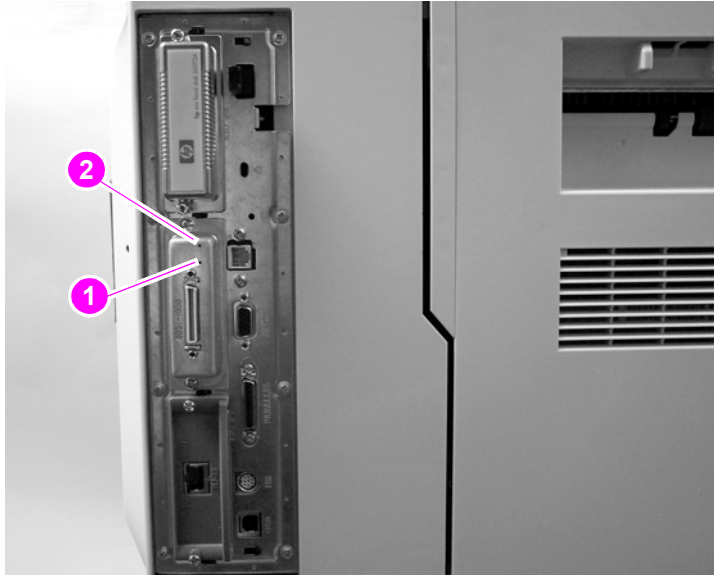
The LED patterns displayed by the HP LaserJet 9000mfp/9000Lmp are opposite those displayed by the HP LaserJet 4100/4101mfp because the CPs are mounted differently.

## HP LJ 9040mfp/9050mfp/9500mfp

The copy processor board (EIO) has two light-emitting diodes (LEDs) (LED 1 callout 1; LED 2 callout 2) located at the back of the MFP. These LEDs illuminate in specific patterns depending on the status of the copy processor board (EIO). The table in this section details what occurs at each stage of copy processor board (EIO) initialization.

### Hint

The LEDs are located on the engine portion of the MFP.



**Figure 205.** Copy processor LEDs (HP LJ 9040mfp/9050mfp/9500mfp)

**Table 61. Copy processor LEDs (HP LJ 9040mfp/9050mfp/9500mfp)**

LED 1	LED 2	CP status
0	1	MFP power turned on. If LED 2 is does not illuminated, the copy processor board (EIO) is not seated correctly, or the copy processor board (EIO) or has failed.
1	1	The copy processor board (EIO) FPGA programming has started. If the copy processor board (EIO) does not processes past this stage, the copy processor board (EIO) has experienced a programming error, or the FPGA integrated circuit on the copy processor board (EIO) has failed. A check cables error will appear on the control-panel display.
0	1	The copy processor board (EIO) FPGA programming has finished. If the copy processor board (EIO) does not processes past this stage, the FPGA integrated circuit on the copy processor board (EIO) has failed. A check cables error will appear on the control-panel display.
1	1	The copy connect board (in the scanner) FPGA programming has started. If the copy processor board (EIO) does not processes past this stage, check the wire harness connectors at the copy processor board (EIO) and the copy connect board (in the scanner). Make sure the cable is not frayed, pinched, or broken. If the error persists, the FPGA integrated circuit on the copy connect board (in the scanner) has failed.
0	1	The copy connect board (in the scanner) FPGA programming has finished. If the copy processor board (EIO) does not processes past this stage, check the wire harness connectors at the copy processor board (EIO) and the copy connect board (in the scanner). Make sure the cable is not frayed, pinched, or broken. If the error persists, the FPGA integrated circuit on the copy connect board (in the scanner) has failed.

**Table 61. Copy processor LEDs (HP LJ 9040mfp/9050mfp/9500mfp) (continued)**

LED 1	LED 2	CP status
0	0	The firmware is being downloaded and confirmed. If the copy processor board (EIO) does not processes past this stage, one or more of the following occurred. <ul style="list-style-type: none"><li>● the memory on the copy processor board (EIO) has failed</li><li>● the operating system did not start</li><li>● the copy processor board (EIO) is locked up</li></ul>
0	1	The operating system has successfully started and the copy processor board (EIO) application has started. If the copy processor board (EIO) does not processes past this stage, the copy processor board (EIO) is locked up, or the copy processor board (EIO) application failed to complete the startup processes.
0	0	The copy processor board (EIO) is initializing the scanner. LED 2 does not illuminate if there is communication between the formatter and the scanner fails, or if the fatal error in the scanner occurs.
0	1	The copy processor board (EIO) successfully established communication between the formatter and the scanner. If the copy processor board (EIO) does not processes past this stage, a problem exists with the Copy Send application (UI).
1	1	The copy processor board (EIO) successfully established communication with the Copy Send application (UI). If the copy processor board (EIO) does not processes past this stage, the copy processor board (EIO) heart beat signal did not start, or the signal is not being sent.
1,0,1,0 (blinking)	1	<ul style="list-style-type: none"><li>● LED 1 displays the copy processor board (EIO) LED heartbeat, indicating copy processor board (EIO) normal operation.</li><li>● If LED 1 stops in the off state, the copy processor board (EIO) application has failed.</li><li>● If LED 2 is off, a fatal error has occurred in the scanner, or the copy processor board (EIO) to scanner connection has failed.</li></ul>

# User- and service-level diagnostics

## Diagnostics

- Print event log
- Show event log
- Paper-path test
- Sensor tests:
  - Paper path
  - Trays
  - Doors
  - Scanner
- Scanner tests:
  - Lower lamp
  - Upper lamp
  - Shutter solenoid
  - Weight solenoid
  - Sensors
  - ADF output motor
  - ADF input motor
  - ADF input reverse
  - Flatbed motor
- Control panel
  - LEDs
  - Display
  - Buttons
  - Touchscreen
- Test
- Service test

## Service test (HP LJ 9000mfp/9000Lmfp/9040mfp/9050mfp)

### Note

For service tests and procedures, see the print engine service manual for your MFP model.

The service test helps to determine whether the print engine is functioning correctly. This test is very useful for isolating MFP problems. The test can be performed with a finishing device attached, but it will not activate any of the finishing device motors, switches, or sensors.

### To perform a service test

- 1 Make sure that the MFP paper path is clear of all media, and that the left, front, and right doors are closed.
- 2 Open tray 2 and tray 3.
- 3 Touch `MENU` to open the menus.
- 4 Scroll to `DIAGNOSTICS`.
- 5 Touch `DIAGNOSTICS` to open that menu.
- 6 Touch `SERVICE TEST`. The service test can take up to two minutes to complete. The control panel shows `PERFORMING SERVICE TEST`.
- 7 When the test is complete, `SERVICE TEST PASSED` should appear on the control panel display or up to five sets of four-digit numbers. If no abnormalities were noted, (0000 0000 0000 0000 0000) should appear. If abnormalities were noted, up to five four-digit codes show up in parentheses (0101 0111 0132 0000 0000). Write down these codes and see table 31 in the HP LaserJet 9000 service manual for an explanation of the codes.
- 8 Close tray 2 and tray 3.

# Service-level diagnostics

## Service menu

Only authorized service personnel should use the MFP service menu commands. The service menu can only be accessed by using a PIN code.

- HP LaserJet 9000mfp/9000Lmfp: 00900001.
- HP LaserJet 9040mfp: 11904004.
- HP LaserJet 9050mfp: 11905004.
- HP Color LaserJet 9500mfp: 11950004.

While in the service menu, you can:

- clear the event log.
- enter a total page count.
- enter a maintenance count.
- enter a maintenance interval.
- enter an ADF count.
- enter a flatbed count.
- enter an ADF simplex count.
- enter a duplex count.
- enter a copy/scan count.
- enter a send/scan count.
- enter a copy pages count.
- set the cold-reset paper size.
- set the following scanner settings:
  - ADF SETTINGS:
    - LEFT SIDE FRONT: adjusts which CCD pixels are used on the CCD array in the flatbed optical unit when using the ADF to scan.
    - LEFT SIDE BACK: adjusts which CCD pixels are used on the CCD array in the ADF optical unit.
    - LEADING EDGE FRONT: adjusts the time between when the pickup motor starts reverse rotation (registration roller mode) and when the CCD starts to read that the pickup motor is rotating.
    - LEADING EDGE BACK: adjusts the time between when the pickup motor starts reverse rotation (registration roller mode) and when the CCD starts to read that the pickup motor is rotating.
    - ADF PLAIN SCALING: adjusts the overall motor speeds of the registration rollers and the delivery rollers.
    - ADF HEAVY SCALING: adjusts the overall motor speeds of the registration rollers and the delivery rollers.
    - MOTOR SPEED PLAIN: adjusts the difference of motor speeds between the registration rollers and the delivery rollers.
    - MOTOR SPEED HEAVY: adjusts the difference of motor speeds between the registration rollers and the delivery rollers.

GLASS SETTINGS:

- LEFT SIDE GLASS: adjusts which CCD pixels are used on the CCD array in the flatbed optical unit when scanning from the flatbed.
- LEADING EDGE GLASS: adjusts the time between when the flatbed optical unit carriage leaves the “home” position and when the CCD on the flatbed optical unit starts to read that the flatbed optical unit is moving.
- GLASS SCALING: adjusts the flatbed optical unit carriage speed.  
SCP firmware
- CLOCK DENSITY SETUP
- ADF TRAY WIDTH CALIBRATION: writes the minimum (A6R) and maximum (A4) width values to the potentiometer.
- SAVE SETTINGS.
- RESTORE SETTINGS.

Perform calibrations if a customer experiences an image defect (image stretch, for example).

Also, perform calibrations if the glass, ADF width sensor, ADF optical unit, or flatbed optical unit are replaced. See See “Calibrations” on page 268.

# Calibrations

Replacing some components requires the MFP to be calibrated. Use the table below to determine what calibration procedures are required after components are replaced.

## CAUTION

Failure to properly calibrate the MFP will result in image quality problems and might cause damage to the MFP.

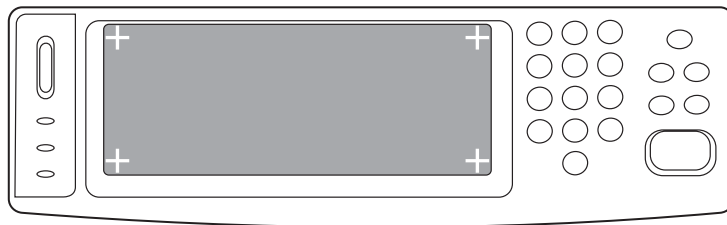
**Table 62. Replaced components and required calibrations**

Replaced component	Required calibration
Glass	<ul style="list-style-type: none"><li>● Leading edge glass</li><li>● Left side glass</li><li>● Leading edge front</li><li>● Left side front</li><li>● ADF plain scaling (ADF heavy scaling if necessary)</li><li>● Glass scaling</li></ul>
ADF width sensor	<ul style="list-style-type: none"><li>● ADF tray width calibration</li></ul>
ADF optical unit	<ul style="list-style-type: none"><li>● Leading edge back</li><li>● Left side back</li></ul>
Flatbed optical unit	<ul style="list-style-type: none"><li>● Leading edge glass</li><li>● Left side glass</li><li>● Leading edge front</li><li>● Left side front</li></ul>

## Control-panel touch screen calibration (HP LJ 9000mfp/9000Lmfp)

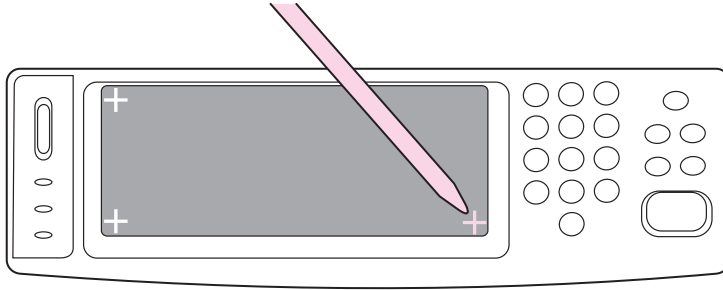
If the touch screen become unresponsive, it may need calibration. Follow the procedure below to calibrate the touch screen.

- 1 Turn the MFP power off.
- 2 Press and hold down the 1, 2, and 3 buttons on the keypad, and then turn the power on. Release the buttons when four crosses appear at the corners of the touch screen display.



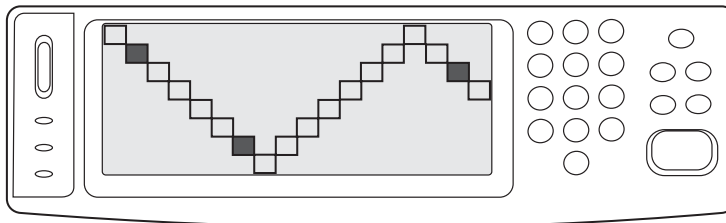
**Figure 206. Calibrate the touch screen (HP LaserJet 9000mfp/9000Lmfp) (1 of 3)**

- 3 Gently touch each cross with a blunt pointed object (like the eraser end of a pencil). The crosses will disappear as they are selected.



**Figure 207. Calibrate the touch screen (HP LaserJet 9000mfp/9000Lmfp) (2 of 3)**

- 4 Turn the MFP power off, and then on.
- 5 Use the control panel to gain access to the **DIAGNOSTIC** menu (see “Diagnostics menu (HP LJ 9000mfp/9000Lmfp/9040mfp/9050mfp)” on page 58).
- 6 Select the **TOUCH SCREEN** option. A series of squares will appear on the control-panel display.
- 7 To verify that the touch screen is accurately calibrated, touch the following squares (the squares should darken as they are touched).
  - the second square from left to right on the display (see figure 208)
  - the seventh square from left to right on the display see figure 208)
  - the seventeenth from left to right on the display see figure 208)



**Figure 208. Calibrate the touch screen (HP LaserJet 9000mfp/9000Lmfp) (3 of 3)**

- 8 If the squares do not darken when they are selected, repeat the calibration procedure.

## Control-panel touch screen calibration (HP LJ 9040mfp/9050mfp/9500mfp)

If the touch screen become unresponsive, it may need calibration. Follow the procedure below to calibrate the touch screen.

- 1 Turn the MFP power off.
- 2 Press and hold down the # (number) and C (clear) buttons on the keypad, and then turn the power on. A single dot will appear at the upper left side of the touch screen display.
- 3 Release the # (number) and C (clear) buttons.
- 4 Gently touch the dot with a blunt pointed object (like the eraser end of a pencil).
- 5 A second dot will appear at the lower right side of the touch screen display.
- 6 Gently touch the dot with a blunt pointed object (like the eraser end of a pencil). The MFP will initialize and be ready for use.

## Scanner/ADF calibration simplified

The following procedure is used to perform a simplified scanner calibration on the MFP. This calibration adjusts the location of the leading edge of the image, left edge image placement, and the scaling (stretch) of the image. This is a simplified method for basic calibration. The original calibration procedure is still available and is recommended if the customer requires full edge-to-edge scanning (HP LJ 9000mfp/9000Lmfp/9040mfp/9050mfp only).

- 1 Make a copy of table 63 in this section (this table is used to record and calculate calibration values during this procedure).
- 2 Perform the set registration procedure for all trays (this calibration *must* be performed using letter or A4 sized media). Follow the instructions on the printed set registration sheet to perform the tray registration.

### Note

See the print quality options in the “Configure device menu (LJ 9000mfp/9000Lmfp/9040mfp/9050mfp)” on page 45 and follow the instructions printed on the set registration page to set the tray registration.

- 3 HP LJ 9000mfp/9000Lmfp/9040mfp/9050mfp only: use the control panel to set `EDGE to EDGE COPIES to ON`.

### Note

See the system setup/copy send options in the “Configure device menu (LJ 9000mfp/9000Lmfp/9040mfp/9050mfp)” on page 45.

- 4 Perform a simplex paper path test from tray 3. Make sure that the printed paper path test pattern is centered on the page. Use the following settings when printing the test page.
  - **MENU/DIAGNOSTICS/PAPER PATH**
  - source: TRAY 3
  - duplex: OFF
  - copies: 1
- 5 Use colored ink to write “ORIGINAL” across the top of the test page.

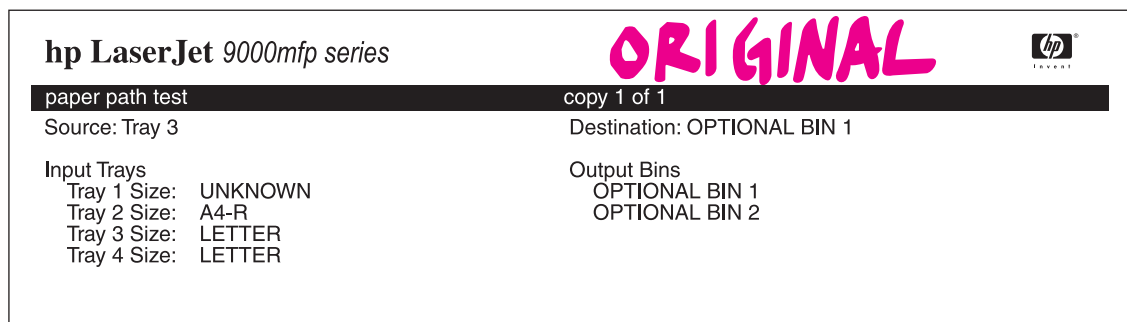
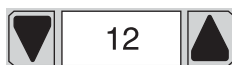


Figure 209. Scanner/ADF test page

- 6 Place the printed paper path test page into the ADF with the top of the page (short edge) into the ADF first (letter-rotated or A4-rotated).
- 7 Make sure that the media in tray 3 is loaded in the letter-rotated or A4-rotated position.
- 8 Make a 100% scaled simplex copy, selecting tray 3 as the source in the **Copy Settings** menu.
- 9 Align the top edges of the *original* and the copied page. Use a metric ruler with a millimeter scale to measure the difference between the top image borders. Record the difference in the ADF Front leading edge (top border) column in table 63.

- 10 Align the left edges of the *original* and the copied page. Use a metric ruler with a millimeter scale to measure the difference in the left image borders. Record the difference in the ADF Front left side border column in table 63.
- 11 Align the top border of the *copy* image with the top border of the original. Use a metric ruler with a millimeter scale to measure the difference in the *bottom* borders. Record the difference in the ADF plain scaling (bottom) column in table 63.
- 12 Place the page that you marked as “ORIGINAL” into the ADF face up. Make sure that the top of the page (short edge) goes into the ADF first.
- 13 Use the control panel to describe the original as 2-sided.
- 14 Use the control panel to describe the copy as 1-sided, and then press the START button.
- 15 Align the top edges of the *original* and the copied page. Use a metric ruler with a millimeter scale to measure the difference between the top image borders. Record the difference in the ADF Leading edge back (top border) column in table 63.
- 16 Align the left edges of the *original* and the copied page. Use a metric ruler with a millimeter scale to measure the difference in the left image borders. Record the difference in the ADF Left side back border column in table 63.
- 17 Open the scanner and place the *original* on the glass. Make sure that the original is loaded with the top edge of the page (short edge) towards the left paper guide (the same orientation as it was loaded in the ADF).
- 18 Make a copy from tray 3.
- 19 Align the top edges of the *original* and the copied page. Use a metric ruler with a millimeter scale to measure the difference between the top image borders. Record the difference in the Glass leading edge (top border) column in table 63.
- 20 Align the left edges of the *original* and the copied page. Use a metric ruler with a millimeter scale to measure the difference in the left image borders. Record the difference in the Glass left side border column in table 63.
- 21 Align the top borders of the *copy* image with the top border of the original. Use a metric ruler with a millimeter scale to measure the difference in the *bottom* borders. Record the difference in the Glass scaling (bottom) column in table 63.
- 22 Use the control panel to open the SERVICE menu.
  - HP LaserJet 9000mfp/9000Lmfp PIN: 00900001
  - HP LaserJet 9040mfp PIN: 11904004
  - HP LaserJet 9050mfp PIN: 11905004
  - HP Color LaserJet 9500mfp PIN: 11950004
- 23 Scroll to and open the SCANNER SETTINGS submenu.
- 24 Select the ADF SETTINGS and then select LEADING EDGE. Record the original value that appears on the control-panel display in table 63.
- 25 Using the calculated value from table 63 adjust the position of the image the number of units using the up or down arrows. For example, if you need to move the ADF Left side back setting 1mm to the right, press the Down arrow on the control panel 12 times.



**Figure 210.** Control-panel up and down arrows

- 26** Repeat steps 23 and 24 for each setting to be adjusted.
- 27** After adjusting the settings, copy the image again to make sure that the image is centered on the copy. If not, repeat this procedure, starting at step 7.
- 28** HP LJ 9000mfp/9000Lmfp/9040mfp/9050mfp only: use the control panel to set **EDGE** to **EDGE COPIES** to OFF, if OFF was the original setting.

**Note**

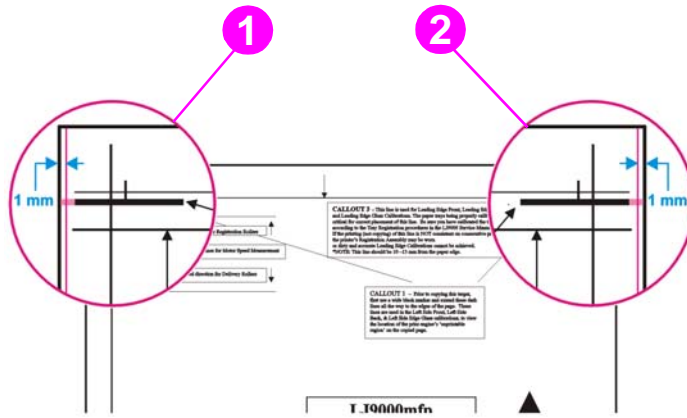
Heavy scaling adjustment values for the ADF can be obtained by using heavy media (supplied by the customer) to print the paper path test page.

**Table 63. Scanner calibration values**

Measurement	Item	Copy image too far	Original value	Action
ADF front side	Leading edge (top border)	High Low  ___mm x 10 = ___ units		If low, press the <b>UP</b> arrow the number of units indicated by the formula. If high, press the <b>DOWN</b> arrow the number of units indicated by the formula.
	Left side	Left Right  ___mm x 12 = ___ units		If left, press the <b>DOWN</b> arrow. If right, press the <b>UP</b> arrow.
	Scaling plain (bottom border)	High Low  ___mm x 3 = ___ units		If low, press the <b>UP</b> arrow. If high, press the <b>DOWN</b> arrow.
ADF back side	Leading edge back (top border)	High Low  ___mm x 10 = ___ units		If low, press the <b>UP</b> arrow. If high, press the <b>DOWN</b> arrow.
	Left side back	Left Right  ___mm x 12 = ___ units		If left, press the <b>UP</b> arrow. If right, press the <b>DOWN</b> arrow.
Glass	Leading edge (top border)	High Low  ___mm x 24 = ___ units		If low, press the <b>UP</b> arrow. If high, press the <b>DOWN</b> arrow.
	Left side	Left Right  ___mm x 12 = ___ units		If left, press the <b>DOWN</b> arrow. If right, press the <b>UP</b> arrow.
	Scaling	High Low  ___mm x 3 = ___ units		If low, press the <b>UP</b> arrow. If high, press the <b>DOWN</b> arrow.



- 4 On the calibration target page, extend the wide line (callout 1) on the top, left corner and the wide line on the top, right corner (callout 2) to the edge of the paper.
- 5 Using a straight edge, draw a line 1 mm (0.04 inch) in from the top, left edge of the page (callout 1) and from the top, right edge of the page (callout 2). Make the lines approximately 30 mm (1.2 inch) long.



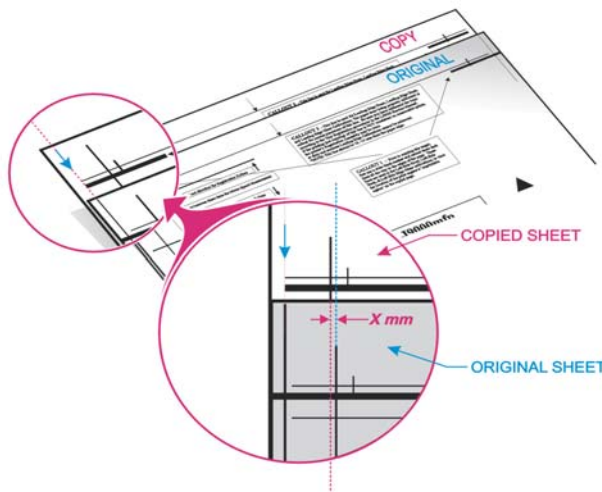
**Figure 212.** Left side front calibration (2 of 4)

- 6 Load the calibration target face down, and copy it using the ADF frontside optical unit.
- 7 Align the edge of the thick, black lines on the copy to the lines drawn on the original calibration target that are 1 mm (0.04 inch) from the edges.

**Note**

Make sure that you can see white on both sides of the calibration target. If not, you cannot perform the necessary measurements.

- 8 On the calibration target, compare the line on the left side of the original to the line on the left side of the copy.



**Figure 213.** Left side front calibration (3 of 4)

- 9 Determine whether the copied page needs to be shifted to the left or to the right. If the copied page needs to be shifted, determine the required distance in millimeters.

- 10 Using the two MFP calibration values charts, determine the value for the left side front that will be entered into the service menu.

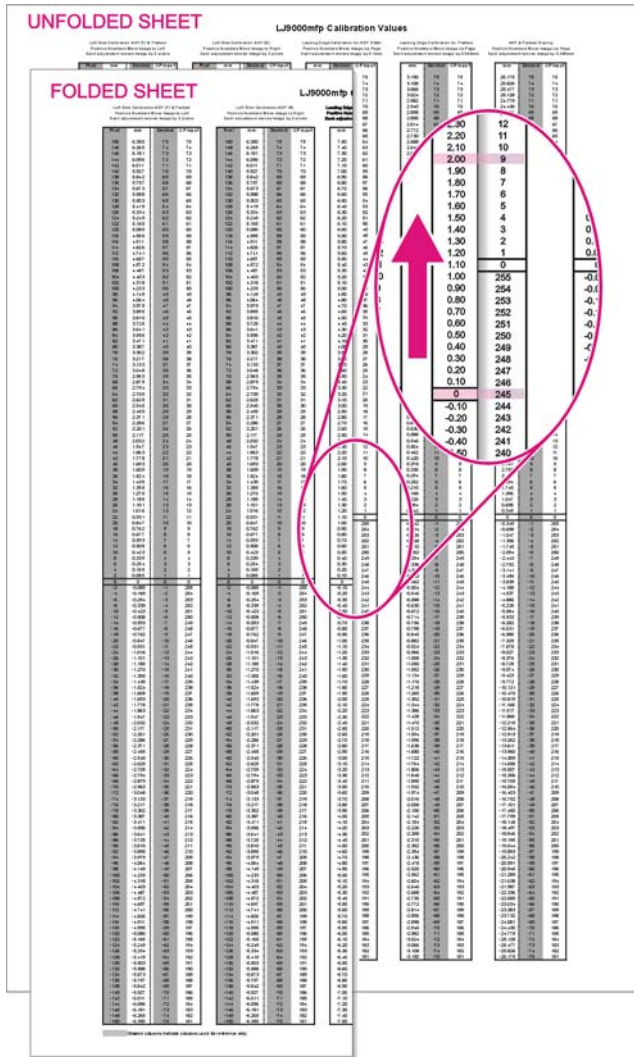


Figure 214. Left side front calibration (4 of 4)

## Left side back calibration

---

### Note

Before beginning the left side back calibration, perform the tray registration calibration on the print engine. To perform the tray registration calibration, touch **MENU**, then touch **CONFIGURE DEVICE**, then touch **PRINT QUALITY**, then touch **SET REGISTRATION**, then touch **SOURCE**, and then touch **PRINT TEST PAGE**. Follow the instructions on the printed registration page to complete the registration setting.

---

---

### Note

Make sure you perform the left side back calibration for all of the trays.

- 1 Download the MFP calibration target and the MFP calibration values chart.
- 2 On the MFP to be calibrated, print the calibration target on ledger or A3 paper. See figure 211.
- 3 Print two copies of the calibration values chart on ledger or A3 paper.
- 4 On the calibration target page, extend the wide line on the top, left corner and the wide line on the top, right corner to the edge of the paper. See figure 212.
- 5 Using a straight edge, draw a line 1 mm (0.04 inch) in from the top, left edge of the page and from the top, right edge of the page. Make the lines approximately 30 mm (1.2 inch) long.
- 6 Load the calibration target face up, and choose “two-sided original to a one-sided copy” to eliminate any print engine duplexing issues.
- 7 Copy the calibration target using the ADF backside optical unit.
- 8 Align the edge of the thick, black lines on the copied calibration target to the lines drawn on the original calibration target that are 1 mm (0.04 inch) from the edges.

---

### Note

Make sure that you can see white on both sides of the calibration target. If not, you cannot perform the necessary measurements.

- 9 On the calibration target, compare the line on the left side of the original to the line on the left side of the copy. See figure 213.
- 10 Determine whether the copied page needs to be shifted to the left or to the right. If the copied page needs to be shifted, determine the required distance in millimeters.
- 11 Using the two HP LaserJet 9000mfp calibration values charts, determine the value for the left side front that will be entered into the service menu. See figure 214.

## Leading edge front calibration

---

### Note

Before beginning the leading edge front calibration, perform the tray registration calibration on the print engine. To perform the tray registration calibration, touch **MENU**, then touch **CONFIGURE DEVICE**, then touch **PRINT QUALITY**, then touch **SET REGISTRATION**, then touch **SOURCE**, and then touch **PRINT TEST PAGE**. Follow the instructions on the printed registration page to complete the registration setting.

---

---

### Note

Make sure you perform the leading edge front calibration for all of the trays.

- 1 Download the MFP calibration target and the MFP calibration values chart.
- 2 On the MFP to be calibrated, print the calibration target on ledger or A3 paper. See figure 211.
- 3 Print two copies of the calibration values chart on ledger or A3 paper.
- 4 Load the calibration target face down, and copy it using the ADF frontside optical unit.
- 5 Align the top edge of the copied calibration target to the top edge of the original calibration target.

---

### Note

Make sure you align the paper edges and *not* the lines.

- 6 On the calibration target, compare the line at the top edge of the original to the line at top edge of the copy.
- 7 Determine if the copied page needs to be shifted up or down. If the copied page needs to be shifted, determine the required distance in millimeters.
- 8 Using the two MFP calibration values charts, determine the value for the leading edge front that will be entered into the service menu. See figure 214.

## Leading edge back calibration

---

### Note

Before beginning the leading edge back calibration, you must perform the tray registration calibration on the print engine. To perform the tray registration calibration, touch **MENU**, then touch **CONFIGURE DEVICE**, then touch **PRINT QUALITY**, then touch **SET REGISTRATION**, then touch **SOURCE**, and then touch **PRINT TEST PAGE**. Follow the instructions on the printed registration page to complete the registration setting.

---

---

### Note

Make sure you perform the leading edge back calibration for all of the trays.

- 1 Download the MFP calibration target and the MFP calibration values chart.
- 2 On the MFP to be calibrated, print the calibration target on ledger or A3 paper. See figure 211.
- 3 Print two copies of the calibration values chart on ledger or A3 paper.
- 4 Load the calibration target face up, and choose “two-sided original to a one-sided copy” to eliminate any print engine duplexing issues.
- 5 Copy the calibration target using the ADF backside optical unit.
- 6 Align the top edge of the copied calibration target to the top edge of the original calibration target.

---

### Note

Make sure you align the paper edges and *not* the lines.

- 7 On the calibration target, compare the line at the top edge of the original to the line at top edge of the copy.
- 8 Determine whether the copied page needs to be shifted up or down. If the copied page needs to be shifted, determine the required distance in millimeters.
- 9 Using the two MFP calibration values charts, determine the value for the leading edge back that will be entered into the service menu. See figure 214.

## ADF plain scaling calibration

---

### Note

Before beginning the ADF plain scaling calibration, perform the tray registration calibration on the print engine. To perform the tray registration calibration, touch **MENU**, then touch **CONFIGURE DEVICE**, then touch **PRINT QUALITY**, then touch **SET REGISTRATION**, then touch **SOURCE**, and then touch **PRINT TEST PAGE**. Follow the instructions on the printed registration page to complete the registration setting.

---

---

### Note

Make sure you perform the ADF plain scaling calibration for all of the trays.

- 1 Download the MFP calibration target and the MFP calibration values chart.
- 2 On the MFP to be calibrated, print the calibration target on ledger or A3 paper. See figure 211.
- 3 Print two copies of the calibration values chart on ledger or A3 paper.
- 4 Load the calibration target face down, and copy it using the ADF frontside optical unit.
- 5 Align the top line of the copied calibration target to the top line of the original calibration target.

---

### Note

Make sure you align the lines and *not* the edges.

- 6 On the calibration target, compare the line at the bottom edge of the original to the line at bottom edge of the copy.
- 7 Determine whether the copied page needs to be lengthened (line shifted down) or shortened (line shifted up). If the copied page needs to be shifted, determine the required distance in millimeters.
- 8 Using the two MFP calibration values charts, determine the value for the ADF plain scaling that will be entered into the service menu. See figure 214.

## ADF heavy scaling calibration

---

**Note** This calibration only needs to be performed if the customer is using heavy media.

---

**Note** Before beginning the ADF heavy scaling calibration, perform the tray registration calibration on the print engine. To perform the tray registration calibration, touch MENU, then touch CONFIGURE DEVICE, then touch PRINT QUALITY, then touch SET REGISTRATION, then touch SOURCE, and then touch PRINT TEST PAGE. Follow the instructions on the printed registration page to complete the registration setting.

---

**Note** Make sure you perform the ADF heavy scaling calibration for all of the trays.

- 1 Download the MFP calibration target and the MFP calibration values chart.
- 2 On the MFP to be calibrated, print the calibration target on *heavy* ledger or A3 paper. See figure 211.
- 3 Print two copies of the calibration values chart on ledger or A3 paper.
- 4 Load the calibration target face down, and copy it using the ADF frontside optical unit.
- 5 Align the top line of the copied calibration target to the top line of the original calibration target.

---

**Note** Make sure you align the lines and *not* the edges.

- 6 On the calibration target, compare the line at the bottom edge of the original to the line at bottom edge of the copy.
- 7 Determine whether the copied page needs to be lengthened (line shifted down) or shortened (line shifted up). If the copied page needs to be shifted, determine the required distance in millimeters.
- 8 Using the two MFP calibration values charts, determine the value for the ADF heavy scaling that will be entered into the service menu. See figure 214.

# Glass calibrations

## Left side glass calibration

---

**Note**

Before beginning the left side glass calibration, perform the tray registration calibration on the print engine. To perform the tray registration calibration, touch **MENU**, then touch **CONFIGURE DEVICE**, then touch **PRINT QUALITY**, then touch **SET REGISTRATION**, then touch **SOURCE**, and then touch **PRINT TEST PAGE**. Follow the instructions on the printed registration page to complete the registration setting.

---

**Note**

Make sure you perform the left side glass calibration for all of the trays.

- 1 Download the MFP calibration target and the MFP calibration values chart.
- 2 On the MFP to be calibrated, print the calibration target on ledger or A3 paper. See figure 211.
- 3 Print two copies of the calibration values chart on ledger or A3 paper.
- 4 On the calibration target page, extend the wide line on the top, left corner and the wide line on the top, right corner to the edge of the paper. See figure 212.
- 5 Using a straight edge, draw a line 1 mm (0.04 inch) in from the top, left edge of the page and from the top, right edge of the page. Make the lines approximately 30 mm (1.2 inch) long.
- 6 Load the calibration target face down on the glass with the left edge of the calibration target toward the back of the glass.
- 7 Copy the calibration target.
- 8 Align the edge of the thick, black lines on the copy to the lines drawn on the original calibration target that are 1 mm (0.04 inch) from the edges.

---

**Note**

Make sure that you can see white on both sides of the calibration target. If not, you cannot perform the necessary measurements.

- 9 On the calibration target, compare the line on the left side of the original to the line on the left side of the copy. See figure 213.
- 10 Determine whether the copied page needs to be shifted to the left or to the right. If the copied page needs to be shifted, determine the required distance in millimeters.
- 11 Using the two MFP calibration values charts, determine the value for the left side glass that will be entered into the service menu. See figure 214.

## Leading edge glass calibration

---

### Note

Before beginning the leading edge glass calibration, perform the tray registration calibration on the print engine. To perform the tray registration calibration, touch **MENU**, then touch **CONFIGURE DEVICE**, then touch **PRINT QUALITY**, then touch **SET REGISTRATION**, then touch **SOURCE**, and then touch **PRINT TEST PAGE**. Follow the instructions on the printed registration page to complete the registration setting.

---

---

### Note

Make sure you perform the leading edge glass calibration for all of the trays.

- 1 Download the MFP calibration target and the MFP calibration values chart.
- 2 On the MFP to be calibrated, print the calibration target on ledger or A3 paper. See figure 211.
- 3 Print two copies of the calibration values chart on ledger or A3 paper.
- 4 Load the calibration target face down on the glass with the left edge of the calibration target toward the back of the glass.
- 5 Copy the calibration target.
- 6 Align the top edge of the copied calibration target to the top edge of the original calibration target.

---

### Note

Make sure you align the paper edges and *not* the lines.

- 7 On the calibration target, compare the line on the left side of the original to the line on the left side of the copy.
- 8 Determine whether the copied page needs to be shifted up or down. If the copied page needs to be shifted, determine the required distance in millimeters.
- 9 Using the two MFP calibration values charts, determine the value for the leading edge glass that will be entered into the service menu. See figure 214.

## Glass scaling calibration

---

### Note

Before beginning the glass scaling calibration, perform the tray registration calibration on the print engine. To perform the tray registration calibration, touch **MENU**, then touch **CONFIGURE DEVICE**, then touch **PRINT QUALITY**, then touch **SET REGISTRATION**, then touch **SOURCE**, and then touch **PRINT TEST PAGE**. Follow the instructions on the printed registration page to complete the registration setting.

---

---

### Note

Make sure you perform the glass scaling calibration for all of the trays.

- 1 Download the MFP calibration target and the MFP calibration values chart.
- 2 On the MFP to be calibrated, print the calibration target on ledger or A3 paper. See figure 211.
- 3 Print two copies of the calibration values chart on ledger or A3 paper.
- 4 Load the calibration target face down on the glass with the left edge of the calibration target toward the back of the glass.
- 5 Copy the calibration target.
- 6 Align the top line of the copied calibration target to the top line of the original calibration target.

---

### Note

Make sure you align the lines and *not* the edges.

- 7 On the calibration target, compare the line at the bottom of the original to the line at the bottom of the copy.
- 8 Determine whether the copied page needs to be lengthened (line shifted down) or shortened (line shifted up). If the copied page needs to be shifted, determine the required distance in millimeters.
- 9 Using the two MFP calibration values charts, determine the value for the glass scaling that will be entered into the service menu. See figure 214.

## Plain motor speed calibration

### Note

Perform this procedure after replacing either of the ADF motors to ensure that the media feeds through the ADF at a uniform speed. After performing this procedure, immediately perform the ADF front and backside scaling procedure.

ADF motor speed calibration reduces variations in media movement speed to produce high quality copy and scan images. This section describes the procedure for calibrating the ADF motor speed for plain media. This procedure requires the use of the A3 or Ledger motor speed calibration target. The correct target must be printed on the correct corresponding media size. Printing the target page on a media size other than the corresponding size will create additional ADF motor speed timing issues.

### Note

Download the calibration motor speed target page from your technical support ASP Web site.

- 1 Perform the set tray calibration procedure for tray 3 (you can use letter- or A4-size media for this step).
- 2 Load tray 3 with A3 or 11 X 17 inch media.
- 3 Print the calibration motor speed target page from tray 3.
- 4 Place the target original face down in the ADF tray with the arrow pointing towards the paper feed direction.
- 5 Make a 100% scaled simplex copy (make sure that you print from tray 3).
- 6 Use a metric ruler (with a millimeter scale) to measure the space between the callout 2 (upper left corner of the target page) and callout 5 (lower right corner of the target page) lines as shown in figure 215 and figure 216. Make sure that you make these measurements on the printed copy. For example, callout 5 is *wider* than callout 2 by XX mm, or callout 5 is *narrower* than callout 2 by XX mm.

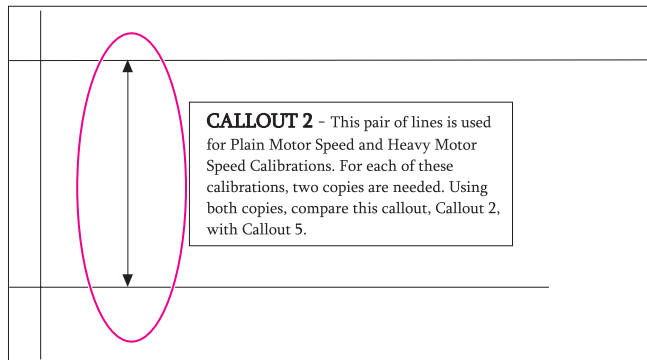


Figure 215. ADF motor speed calibration (1 of 2)

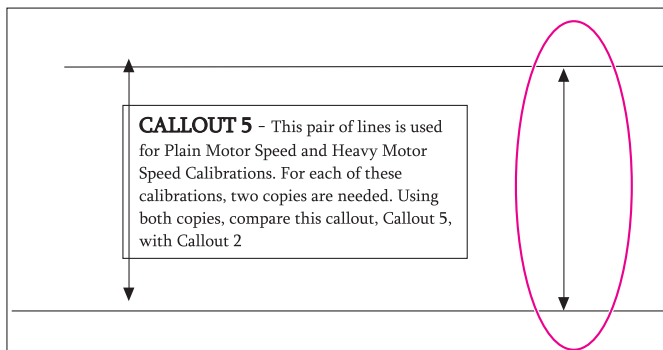


Figure 216. ADF motor speed calibration (1 of 2)

- 7 Record the difference in line spacing in table 64.

**Table 64. ADF motor speed calibration values**

Measurement	Setting	Alignment	Current setting	Action
ADF motor speed	Motor speed plain	Wide Narrow  ___mm x 25 = ___ units		If low, press the <b>UP</b> arrow the number of units indicated by the formula. If high, press the <b>DOWN</b> arrow the number of units indicated by the formula.

- 8 Use the control panel to open the `SERVICE` menu.
  - HP LaserJet 9000mfp/9000Lmfp PIN: 00900001
  - HP LaserJet 9040mfp PIN: 11904004
  - HP LaserJet 9050mfp PIN: 11905004
  - HP Color LaserJet 9500mfp PIN: 11950004
- 9 Open the `SCANNER SETTINGS` submenu.
- 10 Select the `ADF SETTINGS` option and then select `MOTOR SPEED PLAIN`. Record the current setting in table 64. Follow the instructions in the action column of table 64 to make adjustments to the ADF motor speed.

**Note**

The scale column in table 64 is the number of times you must press the indicated button to move the image 1 millimeter. For example, if the spacing between the parallel lines on the copy page is 1 millimeter narrower than on the target calibration page, you would press the down arrow 25 times to increase the spacing by 1 millimeter.

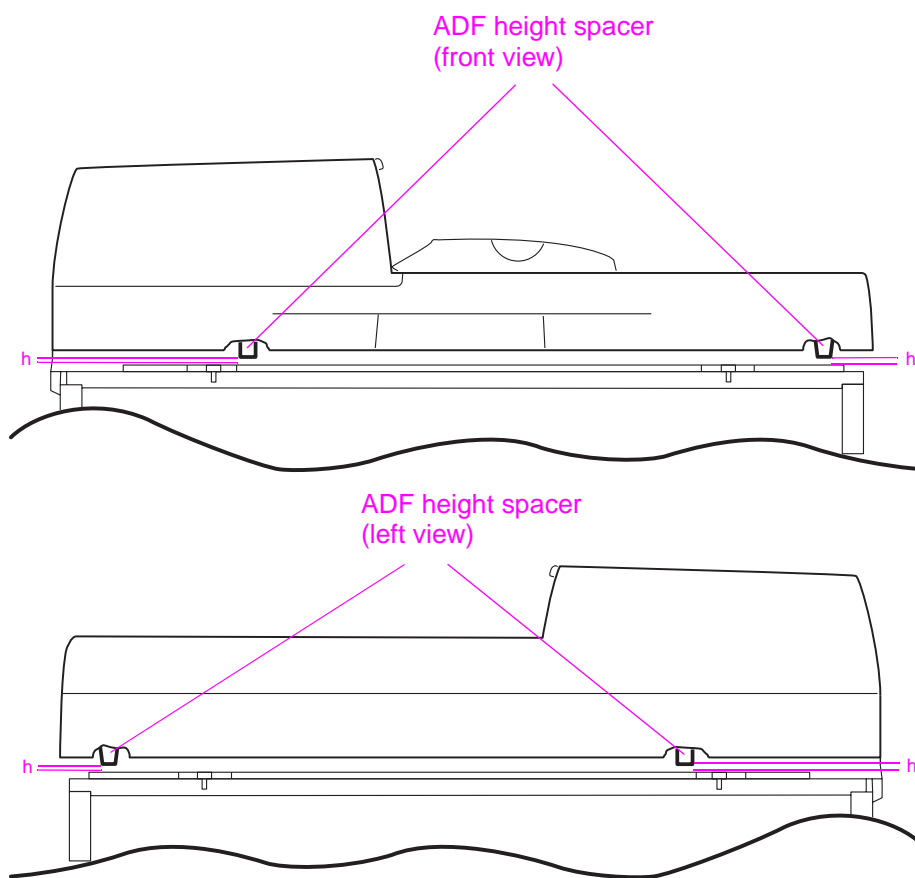
- 11 Repeat steps 4 to 11 to verify correct ADF motor speed calibration. Make additional adjustments as required.
- 12 After performing this calibration, you must perform the ADF front and back side calibration checks. To set the heavy media motor speed, repeat this procedure using the customer's heavy media for the target calibration and copy pages.

# Measurement and adjustment

## ADF unit height adjustment

If the height between the ADF and the glass is not properly adjusted, a transport defect might occur. If a transport defect occurs, check the height between the ADF unit and the glass according to the following procedures and then adjust the gap within the specifications.

- 1 Remove the following covers:
  - ADF back cover—See page 154.
  - Flatbed back cover—See page 160.
  - Flatbed right cover—See page 161.
- 2 Close the ADF unit.
- 3 Measure the gap between the four ADF height spacers and the glass. Make sure the gap is within the ADF unit height adjustment specification ( $h$ ) of 0.7 mm (0.03 inch) or less.

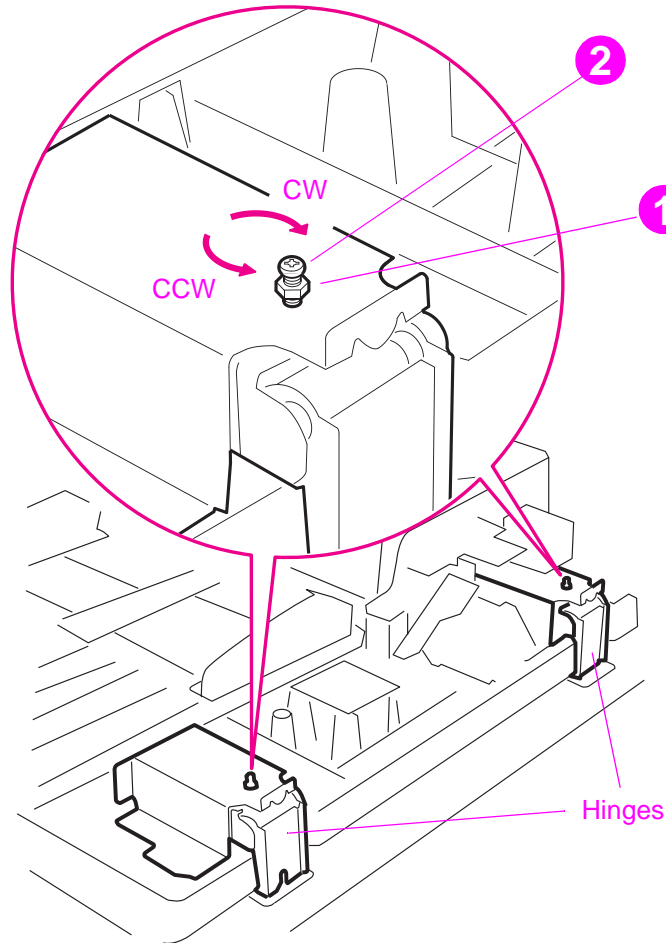


**Figure 217.** ADF unit height adjustment (1 of 2)

- 4 If the gap is not within specifications, loosen the fixing nut (callout 1) and turn the two ADF height adjust screws (callout 2). Turn the screws clockwise (CW) to increase the gap, or counterclockwise (CCW) to decrease the gap.

**Note** The gap will increase or decrease 0.7 mm (0.03 inch) with each rotation of the screw.

**Note** Make sure you loosen the fixing nut (callout 1) before rotating the screw.



**Figure 218.** ADF unit height adjustment (2 of 2)

## ADF skew adjustment

If the ADF unit is not properly aligned on the flatbed, a scanned image skew might occur from the ADF front optics. If an image skew occurs, check the amount of ADF skew and adjust it within specifications.

- 1 Make a copy in the ADF simplex mode by loading a test page face down in the ADF input tray.

### Note

Use a sheet of paper that allows you to measure at least 257 mm (10.1 inches).

- 2 Measure the L1 distance and the L2 distance with a ruler. If the difference between the two distances is equal to or less than 1.5 mm (0.06 inch), the skew is within the ADF skew adjustment specifications.

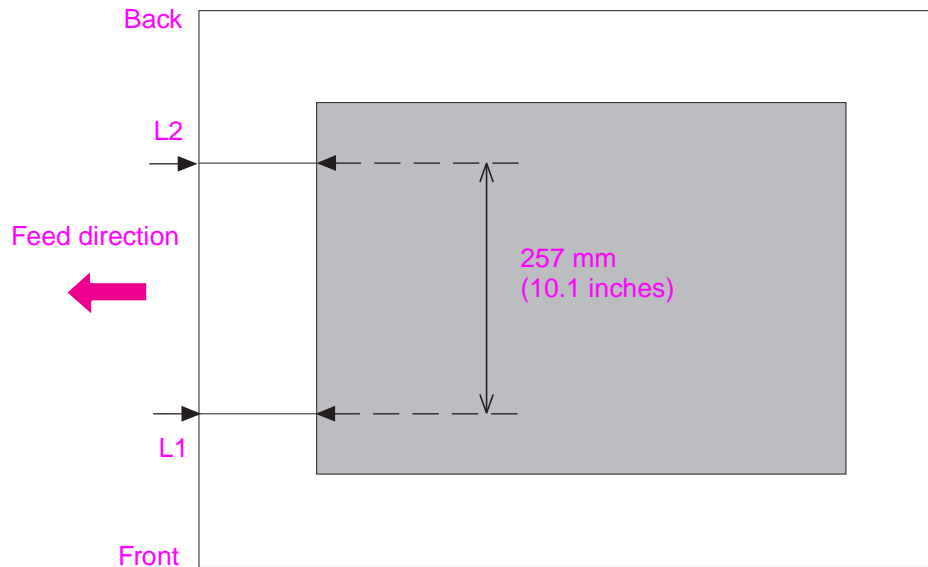


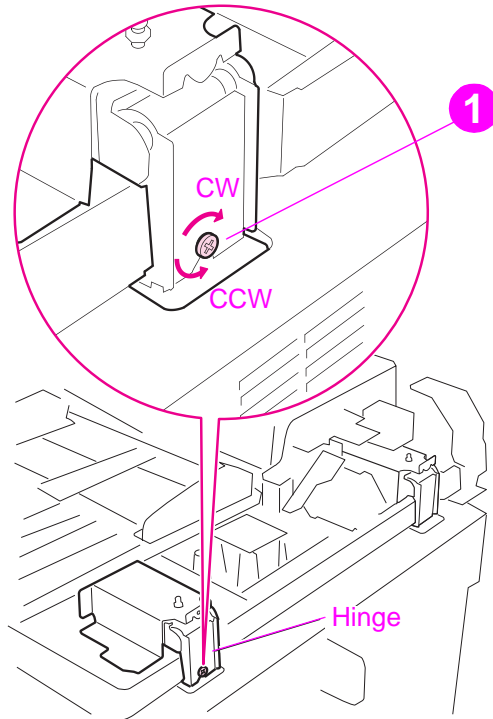
Figure 219. ADF skew adjustment (1 of 3)

- 3 If the distance is not within the ADF skew adjustment specifications, loosen the bracket fixing screw (callout 2 in Figure 220 below) and turn the ADF skew adjusting screw (callout 1). Turn the screw clockwise (CW) to decrease the distance of L1 (increase L2), and counterclockwise to increase the distance of L1 (decrease L2).

---

**Note**

The skew adjusts 0.7 mm (0.03 inch) with each rotation of the ADF skew adjusting screw.

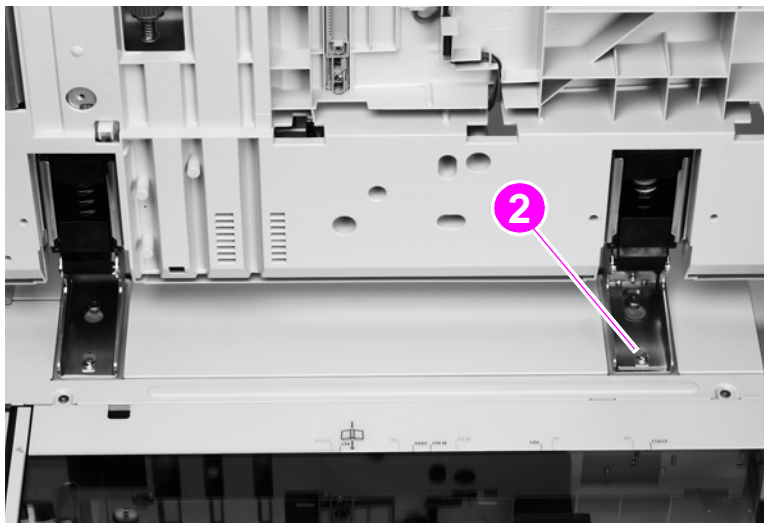


**Figure 220.** ADF skew adjustment (2 of 3)

---

**Note**

Make sure the bracket fixing screw (callout 2) is loosened before beginning the ADF skew adjustment, and make sure the screw is tightened after the adjustment.



**Figure 221.** ADF skew adjustment (3 of 3)

## ADF width sensor adjustment

To perform an ADF width sensor calibration:

- 1 Touch MENU.
- 2 Touch SERVICE MENU.
- 3 Touch SCANNER SETTINGS.
- 4 Touch ADF TRAY WIDTH.
- 5 Follow the instructions on the control panel.
- 6 Move the ADF width guides to A3.
- 7 Touch OK.
- 8 Move the ADF width guides to A6R.

---

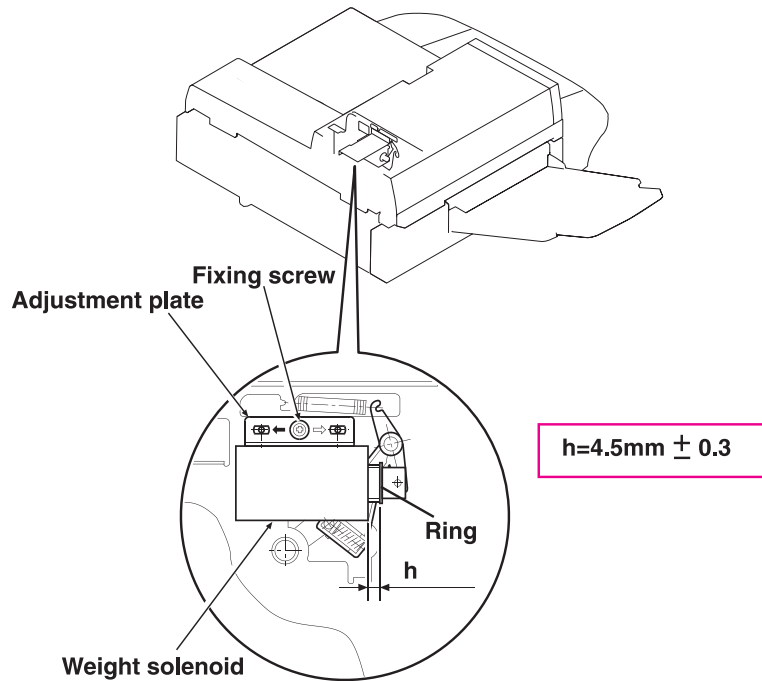
### Note

The A6R size is designated by a white triangle on the ADF.

- 9 Touch OK. The new values are stored.

## Weight solenoid stroke adjustment

Measure the distance “h” with the weight arm lowered. If the distance of “h” is not 4.5 mm (0.18 inch)  $\pm$  0.3 mm (0.012 inch), then loosen the fixing screw and slide the adjustment plate to the left or to the right until the distance “h” is within specifications.



**Figure 222.** Weight solenoid stroke adjustment

# Jam troubleshooting

Jams occur when media either does not reach or does not clear a sensor along the paper path in a specific amount of time. If a jam occurs, a 13.XX PAPER JAM message appears on the MFP control panel.

## Jams

Jams occur most often when the following conditions exist:

- Paper trays are not correctly loaded.
- The print media does not meet the specifications listed in the *HP LaserJet Printer Family Print Media Guide*.
- The media is in poor condition.
- The MFP needs to be cleaned.

If a jam occurs in the print engine, a 13.x PAPER JAM message will appear on the MFP control panel. For detailed descriptions of the 13.x messages and the actions recommended to resolve the errors, see the HP print engine service manual for your MFP model.

If a jam occurs in the scan engine, the MFP control panel shows an ADF PAPER JAM error.

**Table 65. General jam troubleshooting**

Cause	Solution
Improper action of the document shutter.	<ul style="list-style-type: none"><li>● If the spring or arm for the document shutter is out of place, reset it.</li></ul>
Defective shutter solenoid.	<ul style="list-style-type: none"><li>● Replace the shutter solenoid.</li></ul>
Dirty, worn, or deformed weight solenoid.	<ul style="list-style-type: none"><li>● If the weight solenoid is worn or deformed, replace it.</li></ul>
Dirty, worn, or deformed pickup roller.	<ul style="list-style-type: none"><li>● If the pickup roller is dirty, clean it water dampened lint-free cloth.</li><li>● If the pickup roller is worn or deformed, replace it.</li></ul>
Dirty, worn, or deformed feed roller assembly.	<ul style="list-style-type: none"><li>● If the feed roller assembly is dirty, clean it water dampened lint-free cloth.</li><li>● If the feed roller assembly is worn or deformed, replace it.</li></ul>
Dirty, worn, or deformed registration roller assembly <sup>1</sup> .	<ul style="list-style-type: none"><li>● If the registration roller assembly is dirty, clean it water dampened lint-free cloth.</li><li>● If the registration roller assembly is worn or deformed, replace it.</li></ul>
Dirty, worn, or deformed delivery rollers <sup>1</sup> .	<ul style="list-style-type: none"><li>● If the delivery rollers are dirty, clean them water dampened lint-free cloth.</li><li>● If the delivery rollers are worn or deformed, replace them.</li></ul>

<sup>1</sup>Upper and lower

**Table 66. General jam troubleshooting**

Cause	Solution
<b>Multiple feed</b>	
Dirty, worn, or deformed separation belts.	<ul style="list-style-type: none"> <li>● If the separation belts are dirty, clean them water dampened lint-free cloth.</li> <li>● If the separation belts are worn or deformed, replace them.</li> </ul>
Dirty, worn, or deformed feed roller assembly.	<ul style="list-style-type: none"> <li>● If the feed roller assembly is dirty, clean it water dampened lint-free cloth.</li> <li>● If the feed roller assembly is worn or deformed, replace it.</li> </ul>
<b>Wrinkles/folded leading edge</b>	
Dirty, worn, or deformed separation belts.	<ul style="list-style-type: none"> <li>● If the separation belts are dirty, clean them water dampened lint-free cloth.</li> <li>● If the separation belts are worn or deformed, replace them.</li> </ul>
Dirty, worn, or deformed feed roller assembly.	<ul style="list-style-type: none"> <li>● If the feed roller assembly is dirty, clean it water dampened lint-free cloth.</li> <li>● If the feed roller assembly is worn or deformed, replace it.</li> </ul>
Dirty, worn, or deformed registration roller assembly.	<ul style="list-style-type: none"> <li>● If the registration roller assembly is dirty, clean it water dampened lint-free cloth.</li> <li>● If the registration roller assembly is worn or deformed, replace it.</li> </ul>
Dirty, worn, or deformed delivery rollers.	<ul style="list-style-type: none"> <li>● If the delivery rollers are dirty, clean them water dampened lint-free cloth.</li> <li>● If the delivery rollers are worn or deformed, replace them.</li> </ul>
<b>Skew<sup>1</sup></b>	
Paper dust or dirt in the feed roller, registration roller, and/or feed guide.	<ul style="list-style-type: none"> <li>● Clean the dirty area water dampened lint-free cloth.</li> </ul>
Deformed registration roller or feed roller.	<ul style="list-style-type: none"> <li>● Replace the deformed roller.</li> </ul>

<sup>1</sup>If the skew is an ADF backside skew, follow the solutions in the table. If the skew is an ADF frontside skew, see “ADF skew adjustment” on page 289.

# Evaluating the information pages

---

## Note

The sample information pages in this section are from the HP LaserJet 9000mfp/9000Lmfp. Information pages printed from other MFPs will have some variation from these samples (for example the MFP name at the top of the page).

From the MFP control panel, you can print pages that show detailed information about the MFP and its current configuration. The following information pages are available:

- Configuration page
- HP Jetdirect page
- Supplies status page
- File directory page
- Usage page

For a complete list of the MFP information pages, print a menu map. See “Using a menu map (CLJ 9500mfp)” in chapter 3.

To select and print items from the information menu:

- 1 Press **MENU** to enter menus.
- 2 Use **▲** or **▼** to scroll to the **INFORMATION** menu, and select it.
- 3 Use **▲** or **▼** to scroll to the information page you want and select it.

## Configuration page

---

## Note

The sample information pages in this section are from the HP LaserJet 9000mfp/9000Lmfp. Information pages printed from other MFPs will have some variation from these samples (for example the MFP name at the top of the page).

Use the configuration page to view current MFP settings, to help troubleshoot MFP problems, or to verify installation of optional accessories, such as memory (DIMMs), and printer languages.

The content of the configuration page varies, depending on the options currently installed in the MFP.

If any of the installed devices are not shown on the configuration page, verify that the Jet-Link cabling is correctly connected and functional and that dc power is available to the finishing device. Check and reseat suspect cable connections. If any of the cables are replaced, you must turn the power off and back on again to have the MFP recognize the device.

## Configuration page elements

### Note

The sample information pages in this section are from the HP LaserJet 9000mfp/9000Lmfp. Information pages printed from other MFPs will have some variation from these samples (for example the MFP name at the top of the page).

Figure 223 shows a sample configuration page, which contains information about the following attributes:

- A. MFP information
- B. Event log
- C. Installed personalities and options
- D. Memory
- E. Security
- F. Paper trays and options

The image shows a sample configuration page for an HP LaserJet 9000 MFP. The page is divided into six sections, each highlighted with a pink border and a pink circle containing a letter (A-F). The sections are:

- A. Device Information:** Product Name: HP LaserJet 9000 MFP, Device Name: HP LaserJet 9000 MFP, Device Number: 18, Formatter Number: S46XXXXXXXX, Device Serial Number: XXXXXXXXXX, CPB: 1.98 (2.1), SCB: MFP300 17, Firmware Datecode: 20020311 20020311, PS Wait Time-out: 300 seconds, Page Count: 185, Preventive Maintenance Interval: 350000, Pages Since Last Maintenance: 185.
- B. Event Log:** Number of Entries in Use: 0, Maximum Number of Entries: 50, Event Log Is Empty.
- C. Installed Personalities and Options:** PS (20010402), PCLXL (20010402), PCL (20010402), DIMM Slot 1: Side 1: 8 MB Flash, Side 2: 8 MB Flash; DIMM Slot 2: Side 1: 64 MB SDRAM, Side 2: 64 MB SDRAM; DIMM Slot 3: Empty; DIMM Slot 4: Empty; EIO 1: HP JetDirect J6057A; EIO 2: HP J6054A; EIO 3: TI PCILynx; DISK Storage: 4641 MB Capacity; LDAP Gateway: 15.56.8.155; SMTP Gateway: 15.56.8.201.
- D. Memory:** Total Memory: 128 MB, DWS: 57.87, Automatic Resource Saving Enabled.
- E. Security:** Control Panel Lock: NONE, Control Panel Password: DISABLED, Write Protect: DISABLED.
- F. Paper Trays and Options:** Default Paper Size: LETTER, Tray 1 Size: UNKNOWN, Tray 2 Size: LETTER, Tray 3 Size: 11X17, Duplex Unit, Device 1: HEWLETT-PACKARD, 2000 SHEETS INPUT TRAY [03.26] C8531A, Input Trays: 1: TRAY 4, 2000 Sheets; Device 2: HEWLETT-PACKARD, HP MULTIFUNCTION FINISHER [020219] C8088A, Output Bins: 1: OPTIONAL BIN 1, 1000 Sheets, Face Up/Down; 2: OPTIONAL BIN 2, 250 Sheets, Face Down.

ENGLISH 13

Figure 223. Sample configuration page (HP LJ 9000mfp/9000Imp shown)

## Jetdirect page

### Note

The sample information pages in this section are from the HP LaserJet 9000mfp/9000Lmfp. Information pages printed from other MFPs will have some variation from these samples (for example the MFP name at the top of the page).

For the HP LaserJet 9040mfp/9050mfp and the HP Color LaserJet 9500mfp, a third output device configuration page will print with the printer configuration and Jetdirect pages.

Use the Jetdirect page to view current network settings, to help troubleshoot MFP problems, or to verify network statistics or protocol information.

### Jetdirect page elements

- A. HP Jetdirect configuration
- B. Security settings
- C. Network statistics
- D. TCP/IP status
- E. IPX/SPX status
- F. Novell/Netware settings
- G. AppleTalk status
- H. DLC/LLC status

The image shows a sample Jetdirect page for an HP LaserJet 9000mfp series printer. The page is titled "EIO 1 - JetDirect Page" and contains several sections of configuration information, each highlighted with a pink box and a lettered label (A-H) in a pink circle. The sections are:

- A. HP JetDirect Configuration:** Status: I/O Card Ready; Model Number: J6057A; Hardware Address: 0001E6627404; Firmware Version: R 22.09; Port Config: 10BASE-T HALF; Auto Negotiation: On; Manufacturing ID: 22014203902201; Date Manufactured: 01/2002.
- B. Security Settings:** Admin Password: Not Specified; SSL/TLS: Disabled; Cert Expires: Not Applicable; SNMP Versions: 1-2; SNMP Set Cmty Name: Not Specified; Access List: Not Specified.
- C. Network Statistics:** Total Packets Received: 344285; Unicast Packets Received: 19292; Bad Packets Received: 0; Framing Errors Received: 0; Total Packets Transmitted: 22056; Undeliverable Packets: 0; Transmit Collisions: 130; Transmit Late Collisions: 0.
- D. TCP/IP:** Status: Ready; Host Name: NP1627404; IP Address: 15.237.22.20; Subnet Mask: 255.255.252.0; Default Gateway: 15.237.20.1; Config By: DHCP; DHCP Server: 15.235.128.30; TFTP Servers: Not Specified; Config File: Not Specified; Domain Name: bo1.hp.com; DNS Server: 15.235.128.51; WINS Server: 15.56.40.21; Syslog Server: Not Specified; Idle Timeout: 270 sec; Web JetAdmin URL: Not Specified.
- E. IPX/SPX:** Status: Initializing; Primary Frame Type: Auto Select; Network Frame Type: Rcvd; Unknown EN II: 5699; Unknown EN 802.2: 48365; Unknown EN SNMP: 5017; Unknown EN 802.3: 19558.
- F. Novell/Netware:** Status: 16; NOT CONFIGURED; Node Name: NP1627404; NetWare Mode: Queue Server; NDS Tree Name: NDS Context: Attached Server: 60 sec; SAP Interval: 60 sec.
- G. AppleTalk:** Status: Ready; Name: HP LaserJet 9000 MFP; Zone: HP LaserJet; Type 1: LaserWriter; Type 2: 65281; Network Number: 65281; Node Number: 53.
- H. DLC/LLC:** Status: Ready.

Figure 224. Sample Jetdirect page (HP LJ 9000mfp/9000Lmfp shown)

## Supplies status page

### Note

The sample information pages in this section are from the HP LaserJet 9000mfp/9000Lmfp. Information pages printed from other MFPs will have some variation from these samples (for example the MFP name at the top of the page).

Use the supplies status page to view the current MFP supply status, to help troubleshoot MFP problems, or to verify MFP information.

### Supplies page elements

- A. Supplies-ordering information
- B. Cartridge information
- C. Other supplies information
- D. MFP information

**hp LaserJet 9000mfp series**

supplies status page 1

Hewlett-Packard Supplies can be ordered on the internet at <https://www.hp.com/go/ordersupplies-na> or by calling Hewlett-Packard. (Please refer to your printer User Manual for the telephone number).  
For highest print quality always use genuine Hewlett-Packard LaserJet supplies.

**Cartridge Information**

HP Black TonerGauge 41%

HP Part Number: C8543X  
Toner Low Reached: NO  
Toner Out Reached: NO  
Estimated Pages Remaining: 5016  
(Based on this printer's historical page coverage of 2%)

Page Count by Paper Size:

A3/Ledger:	56
Legal:	3
A4/Letter:	7083
B5/Executive:	0
Envelope:	0
Custom/Other:	77

Total Pages Printed: 7219  
Number of Jobs Processed: 1791

Cartridge Manufacture Date: 20010123  
Cartridge Serial Number: 205  
Marked as Reordered: NO

Please return your used HP cartridge to Hewlett-Packard. For more information see:  
<http://www.hp.com/go/recycle>

**Other Supplies Information**

HP Maintenance Kit 99%

HP Part Numbers:  
110V C9152A  
220V C9153A

**Device Information**

Total Printer Page Count: 187  
Preventive Maintenance Interval: 350000  
Pages Until Next Maintenance: 349813  
Device Serial Number: XXXXXXXXXX

ENGLISH (1)

Figure 225. Sample supplies status page (HP LJ 9000mfp/9000Lmfp shown)

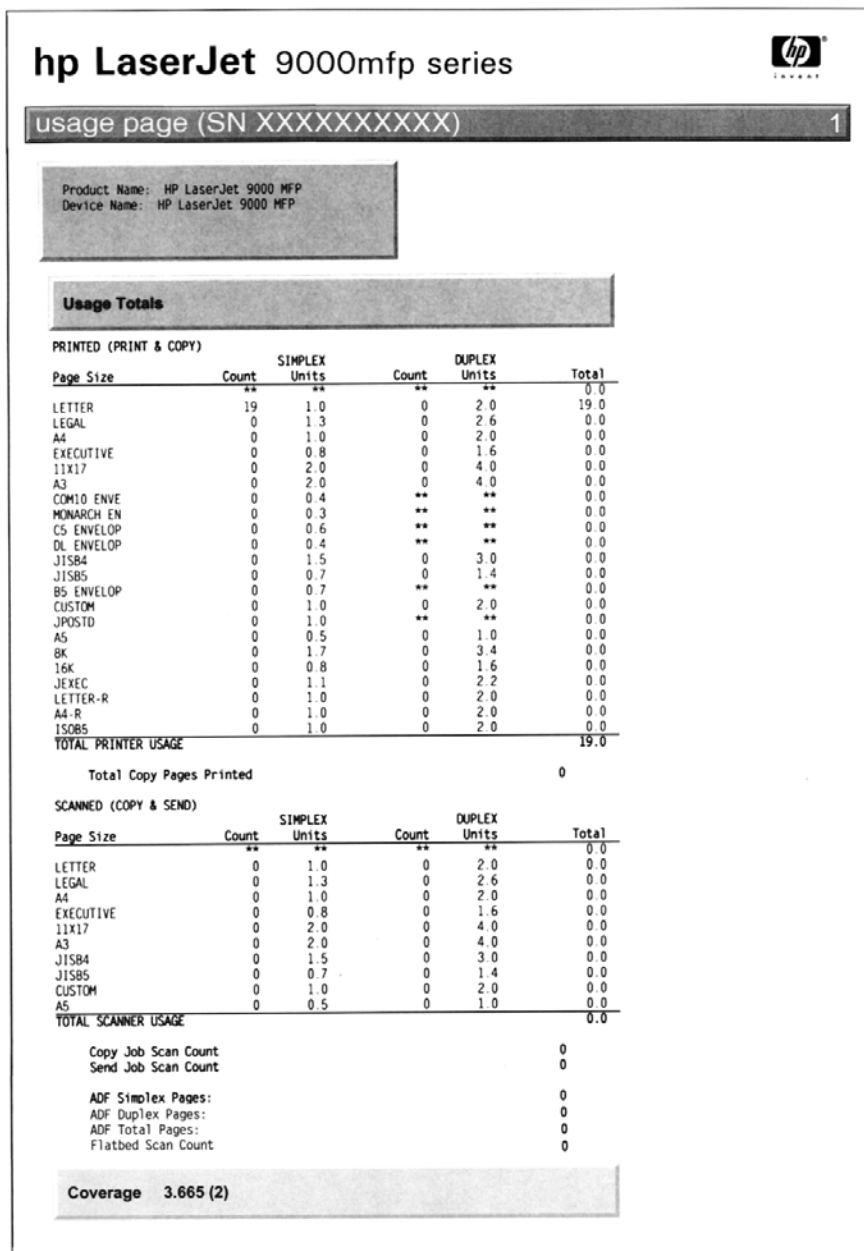
# Usage page

**Note**

The sample information pages in this section are from the HP LaserJet 9000mfp/9000Lmfp. Information pages printed from other MFPs will have some variation from these samples (for example the MFP name at the top of the page).

The usage page is designed to fit into a pay-per-page (PPP) model. A reseller can configure the usage page with instructions that a user can send the information back to the reseller in order to prepare bills.

Print a usage page from the MFP control panel (or gain access to the information remotely from HP Web JetAdmin) to determine how many simplex or duplex pages of each paper size have been scanned on the copy module and printed on the MFP. Average toner coverage is approximated by counting pixels. Jams are not counted. The data cannot be reset manually, and values such as total print and scan impressions, toner coverage, serial number, default language, and default paper size are backed up between the MFP NVRAM and the hard disk.



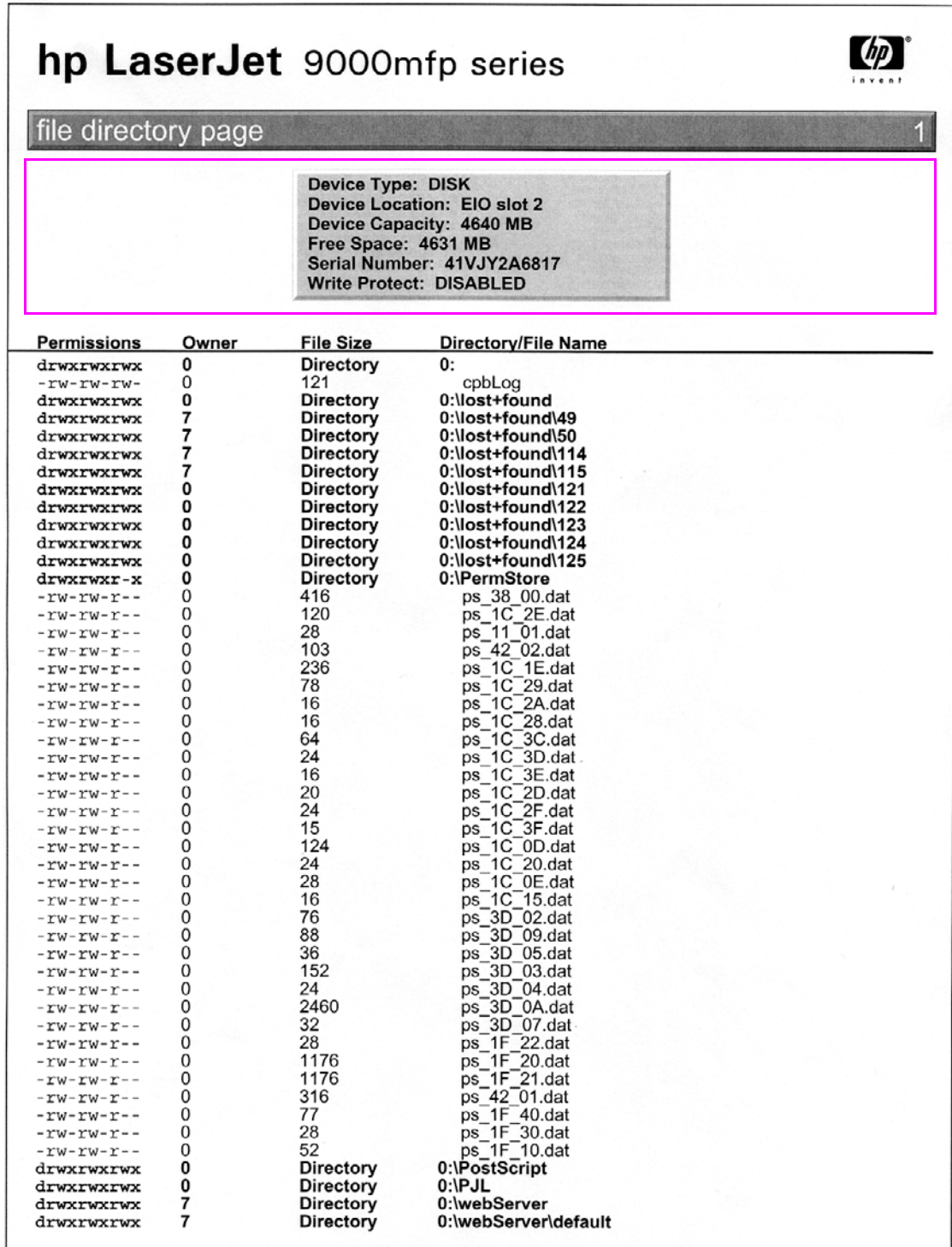
**Figure 226.** Sample usage page (HP LJ 9000mfp/9000Lmfp shown)

## File directory page

Use the file directory page to view current directory structures, to help troubleshoot MFP problems, or to verify storage capabilities.

### File directory page elements

Directory information



**hp LaserJet 9000mfp series**

file directory page 1

Device Type: DISK  
Device Location: EIO slot 2  
Device Capacity: 4640 MB  
Free Space: 4631 MB  
Serial Number: 41VJY2A6817  
Write Protect: DISABLED

Permissions	Owner	File Size	Directory/File Name
drwxrwxrwx	0	Directory	0:
-rw-rw-rw-	0	121	cpbLog
drwxrwxrwx	0	Directory	0:\lost+found
drwxrwxrwx	7	Directory	0:\lost+found\49
drwxrwxrwx	7	Directory	0:\lost+found\50
drwxrwxrwx	7	Directory	0:\lost+found\114
drwxrwxrwx	7	Directory	0:\lost+found\115
drwxrwxrwx	0	Directory	0:\lost+found\121
drwxrwxrwx	0	Directory	0:\lost+found\122
drwxrwxrwx	0	Directory	0:\lost+found\123
drwxrwxrwx	0	Directory	0:\lost+found\124
drwxrwxrwx	0	Directory	0:\lost+found\125
drwxrwxr-x	0	Directory	0:\PermStore
-rw-rw-r--	0	416	ps_38_00.dat
-rw-rw-r--	0	120	ps_1C_2E.dat
-rw-rw-r--	0	28	ps_11_01.dat
-rw-rw-r--	0	103	ps_42_02.dat
-rw-rw-r--	0	236	ps_1C_1E.dat
-rw-rw-r--	0	78	ps_1C_29.dat
-rw-rw-r--	0	16	ps_1C_2A.dat
-rw-rw-r--	0	16	ps_1C_28.dat
-rw-rw-r--	0	64	ps_1C_3C.dat
-rw-rw-r--	0	24	ps_1C_3D.dat
-rw-rw-r--	0	16	ps_1C_3E.dat
-rw-rw-r--	0	20	ps_1C_2D.dat
-rw-rw-r--	0	24	ps_1C_2F.dat
-rw-rw-r--	0	15	ps_1C_3F.dat
-rw-rw-r--	0	124	ps_1C_0D.dat
-rw-rw-r--	0	24	ps_1C_20.dat
-rw-rw-r--	0	28	ps_1C_0E.dat
-rw-rw-r--	0	16	ps_1C_15.dat
-rw-rw-r--	0	76	ps_3D_02.dat
-rw-rw-r--	0	88	ps_3D_09.dat
-rw-rw-r--	0	36	ps_3D_05.dat
-rw-rw-r--	0	152	ps_3D_03.dat
-rw-rw-r--	0	24	ps_3D_04.dat
-rw-rw-r--	0	2460	ps_3D_0A.dat
-rw-rw-r--	0	32	ps_3D_07.dat
-rw-rw-r--	0	28	ps_1F_22.dat
-rw-rw-r--	0	1176	ps_1F_20.dat
-rw-rw-r--	0	1176	ps_1F_21.dat
-rw-rw-r--	0	316	ps_42_01.dat
-rw-rw-r--	0	77	ps_1F_40.dat
-rw-rw-r--	0	28	ps_1F_30.dat
-rw-rw-r--	0	52	ps_1F_10.dat
drwxrwxrwx	0	Directory	0:\PostScript
drwxrwxrwx	0	Directory	0:\PjL
drwxrwxrwx	7	Directory	0:\webServer
drwxrwxrwx	7	Directory	0:\webServer\default

Figure 227. Sample file directory page (HP LJ 9000mfp/9000Lmfp shown)

# Image-formation troubleshooting

When working with customers, obtain a print sample before troubleshooting the MFP. Also, ask the customer to describe the quality expected from the MFP. The print sample helps clarify the customer's description of the problem.

Often an image-formation problem can be linked to media that is outside the specifications that Hewlett-Packard has established for optimum MFP performance. See "Measurement and adjustment" on page 287 for help with persistent image-formation problems.

**Table 67. Image quality checks**

<b>Image quality checks</b>	<b>Action</b>
Is the image defect on printed pages?	See image formation troubleshooting in the print engine service manual for your MFP model.
Does the problem repeat on the page?	See "Measurement and adjustment" on page 287.
Is the customer using print media that meets all HP specifications?	See "Measurement and adjustment" on page 287.
Is the customer using the appropriate setting to describe the original before copying?	See ORIGINALS in the "Configure device menu (CLJ 9500mfp)" on page 64.
Is the print quality problem associated with the ADF or the glass?	See "Copy-image defects" on page 302. Compare the sample to the tables and perform the recommended actions.
Is the print sample similar to those in the image defect tables?	See "Copy-image defects" on page 302. Compare the sample to the tables and perform the recommended actions.
Does the media meet HP standards?	See "Measurement and adjustment" on page 287.

## Copy-image defects

This section defines copy-image defects and helps isolate the MFP component that is the cause of a copy-image defect.


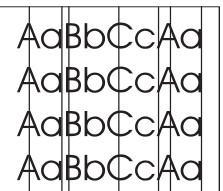

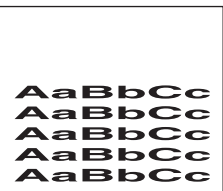
The first step in isolating a possible copy-image defect, is to eliminate the print engine as the cause of the defect. Print several pages that tend to show the defect from a host computer. If the defect appears on the printed pages, use the print engine service manual for the MFP to further isolate the image defect and its cause. See the *HP LaserJet 9000 and 9050 Printer Service Manual* or the *HP Color LaserJet 9500/9500mfp Print Engine Service Manual*.

If the image defect does not appear on the printed page, the next step is to isolate the defect to a scan location, or the source of the copies. The image defect can be caused by the following scan locations.


- ADF front side (simplex). See table 68 on page 303.
- ADF back side (duplex, second side). See table 69 on page 304.
- Flatbed glass. See table 70 on page 306.
- All of the above scan locations. See table 71 on page 307.

After the copy-image defect is isolated to a scan location, use the corresponding tables in this section to determine the type of defect (for example, blank pages or vertical lines), and then to identify the MFP component that is most likely the cause that type of defect.


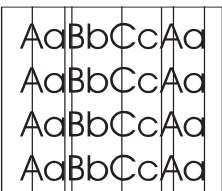
**Table 68. ADF simplex (front side)**

Defect	Cause	Solution LJ 9000mfp/9000Lmfp	Solution LJ 9040mfp/9050mfp/9500mfp
<p><b>Blank page</b></p> 	Dirty white calibration strips.	Clean the white calibration strip on the delivery roller cover. If the problem persists, replace the delivery roller cover.	Clean the white calibration strip on the delivery roller cover. If the problem persists, replace the delivery roller cover.
	Defective flatbed inverter PCB.	Replace the flatbed inverter PCB.	Replace the flatbed optical assembly.
	Defective flatbed scanning lamp.	Replace the flatbed scanning lamp.	Replace the flatbed optical assembly.
	Defective flatbed CCD driver.	Replace the flatbed optical assembly.	Replace the flatbed optical assembly.
<p><b>Vertical lines</b></p> 	Foreign substances deposited on the pickup roller.	Clean the pickup roller. If the problem persists, replace the pickup roller.	Clean the pickup roller. If the problem persists, replace the pickup roller.
	Foreign substances deposited on the weight plate.	Clean the weight plate. If the problem persists, replace the weight plate.	Clean the weight plate. If the problem persists, replace the weight plate.
	Foreign substances deposited on the feed rollers.	Clean the feed rollers. If the problem persists, replace the feed rollers.	Clean the feed rollers. If the problem persists, replace the feed rollers.
	Foreign substances deposited on the registration rollers.	Clean the registration roller (upper and lower). If the problem persists, replace the registration rollers.	Clean the registration roller (upper and lower). If the problem persists, replace the registration rollers.
	Defective flatbed CCD driver.	Replace the flatbed optical assembly.	Replace the flatbed optical assembly.
	Defective scanner controller board.	Replace the scanner controller board.	Replace scanner controller board.
<p><b>Horizontal lines</b></p> 	Dirty glass.	Clean the glass strip that is left of the size guide.	Clean the glass strip that is left of the size guide.
	Dirty calibration strip (ADF) or square (under the glass).	Clean the calibration strip (ADF) or square (under the glass).	Clean the calibration strip (ADF) or square (under the glass).
	Scars on the back of the glass.	Clean the white calibration strips on the back of the glass. If the problem persists, replace the glass.	Clean the white calibration strips on the back of the glass. If the problem persists, replace the glass.
	Defective flatbed inverter PCB.	Replace the flatbed inverter PCB.	Replace the flatbed optical assembly.
	Defective flatbed CCD driver.	Replace the flatbed optical assembly.	Replace the flatbed optical assembly.
	Defective scanner controller board.	Replace the scanner controller board.	Replace scanner controller board.
<p><b>Stretched/shrunk image</b></p> 	Incorrect motor speeds driving the registration rollers and delivery motors.	Perform the motor speed calibration, and then the ADF front scaling calibration, and then the ADF back scaling calibration procedures.	Perform the motor speed calibration, and then the ADF front scaling calibration, and then the ADF back scaling calibration procedures.


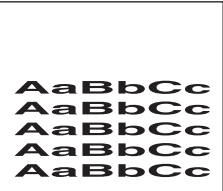

**Table 68. ADF simplex (front side) (continued)**

Defect	Cause	Solution LJ 9000mfp/9000Lmfp	Solution LJ 9040mfp/9050mfp/9500mfp
<p>Skewed image</p> 	See page 294.	See page 294.	See page 294.


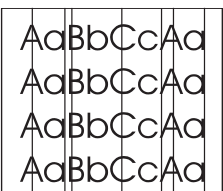

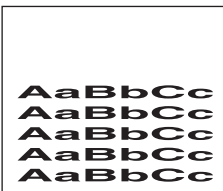

**Table 69. ADF duplex (second side)**

Defect	Cause	Solution LJ 9000mfp/9000Lmfp	Solution LJ 9040mfp/9050mfp/9500mfp
<p>Blank page</p> 	Defective ADF inverter PCB.	Replace the ADF inverter PCB.	Replace the ADF optical assembly.
	Defective ADF analog processor PCB.	Replace the ADF analog processor PCB.	Replace the ADF optical assembly.
	Defective ADF scanning lamp.	Replace the ADF scanning lamp.	Replace the ADF optical assembly.
	Defective ADF CCD driver.	Replace the ADF optical assembly.	Replace the ADF optical assembly.
<p>Vertical lines</p> 	Scars on the white calibration strips on the back of the glass.	Clean the white calibration strips on the back of the glass.	Clean the white calibration strips on the back of the glass.
	Foreign substances deposited on the pickup roller.	Clean the pickup roller. If the problem persists, replace the pickup roller.	Clean the pickup roller. If the problem persists, replace the pickup roller.
	Foreign substances deposited on the weight plate.	Clean the weight plate. If the problem persists, replace the weight plate.	Clean the weight plate. If the problem persists, replace the weight plate.
	Foreign substances deposited on the feed rollers.	Clean the feed rollers. If the problem persists, replace the feed rollers.	Clean the feed rollers. If the problem persists, replace the feed rollers.
	Foreign substances deposited on the registration rollers.	Clean the registration roller (upper and lower). If the problem persists, replace the registration rollers.	Clean the registration roller (upper and lower). If the problem persists, replace the registration rollers.
	Defective ADF analog processor PCB.	Replace the ADF analog processor PCB.	Replace the ADF optical assembly.
	Defective ADF CCD driver.	Replace the ADF optical assembly.	Replace the ADF optical assembly.
	Defective scanner controller board.	Replace the scanner controller board.	Replace scanner controller board.


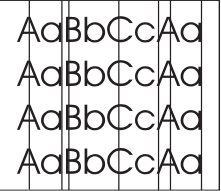
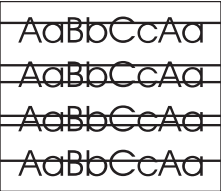
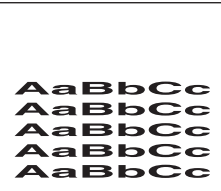

**Table 69. ADF duplex (second side) (continued)**

Defect	Cause	Solution LJ 9000mfp/9000Lmfp	Solution LJ 9040mfp/9050mfp/9500mfp
<p><b>Horizontal lines</b></p> 	<p>Dirty ADF glass (flip-down).</p> <p>Scars on the white calibration strips on the delivery cover.</p> <p>Defective ADF analog processor PCB.</p> <p>Defective ADF inverter PCB.</p> <p>Defective ADF scanning lamp.</p> <p>Defective ADF CCD driver.</p> <p>Defective scanner controller board.</p>	<p>Open the ADF. Release the blue flip-down glass latch (located toward the control panel end of the glass), and clean both sides of the flip-down glass.</p> <p>Clean the white calibration strip on the delivery roller cover. If the problem persists, replace the delivery roller cover.</p> <p>Replace the ADF analog processor PCB.</p> <p>Replace the ADF inverter PCB.</p> <p>Replace the ADF scanning lamp.</p> <p>Replace the ADF optical assembly.</p> <p>Replace the scanner controller board.</p>	<p>Open the ADF. Release the blue flip-down glass latch (located toward the control panel end of the glass), and clean both sides of the flip-down glass.</p> <p>Clean the white calibration strip on the delivery roller cover. If the problem persists, replace the delivery roller cover.</p> <p>Replace the ADF optical assembly.</p> <p>Replace the ADF optical assembly.</p> <p>Replace the ADF optical assembly.</p> <p>Replace the ADF optical assembly.</p> <p>Replace scanner controller board.</p>
<p><b>Stretched/shrunk image</b></p> 	<p>Incorrect motor speeds driving the registration rollers and delivery motors.</p>	<p>Perform the motor speed calibration, and then the ADF front scaling calibration, and then the ADF back scaling calibration procedures.</p>	<p>Perform the motor speed calibration, and then the ADF front scaling calibration, and then the ADF back scaling calibration procedures.</p>
<p><b>Skewed image</b></p> 	<p>See page 294.</p>	<p>See page 294.</p>	<p>See page 294.</p>

**Table 70. Flatbed glass**

<b>Defect</b>	<b>Cause</b>	<b>Solution LJ 9000mfp/9000Lmfp</b>	<b>Solution LJ 9040mfp/9050mfp/9500mfp</b>
<p><b>Blank page</b></p> 	Dirty white calibration strips.	Clean the white calibration strip on the back of the glass. If the problem persists, replace the glass.	Clean the white calibration strip on the back of the glass. If the problem persists, replace the glass.
	Defective flatbed inverter PCB.	Replace the flatbed inverter PCB.	Replace the flatbed optical assembly.
	Defective flatbed scanning lamp.	Replace the flatbed scanning lamp.	Replace the flatbed optical assembly.
	Defective flatbed CCD driver.	Replace the flatbed optical assembly.	Replace the flatbed optical assembly.
<p><b>Vertical lines</b></p> 	Defective flatbed CCD driver.	Replace the flatbed optical assembly.	Replace the flatbed optical assembly.
	Defective scanner controller board.	Replace the scanner controller board.	Replace scanner controller board.
<p><b>Horizontal lines</b></p> 	Scars on the back of the glass.	Clean the white calibration strip on the back of the glass. If the problem persists, replace the glass.	Clean the white calibration strip on the back of the glass. If the problem persists, replace the glass.
	Defective flatbed inverter PCB.	Replace the flatbed inverter PCB.	Replace the flatbed optical assembly.
	Defective flatbed CCD driver.	Replace the flatbed optical assembly.	Replace the flatbed optical assembly.
	Defective scanner controller board.	Replace the scanner controller board.	Replace scanner controller board.
<p><b>Stretched/shrunk image</b></p> 	Incorrect motor speeds driving the flatbed optical assembly.	Perform the flatbed glass scaling calibration procedure.	Perform the flatbed glass scaling calibration procedure.
<p><b>Skewed image</b></p> 	N/A	N/A	N/A

**Table 71. All scan locations**

Defect	Cause	Solution LJ 9000mfp/9000Lmfp	Solution LJ 9040mfp/9050mfp/9500mfp
<p>Blank page</p> 	Defective scanner controller board.	Replace the scanner controller board.	Replace scanner controller board.
	Defective copy processor.	Replace the copy processor board.	Replace the copy processor EIO.
<p>Vertical lines</p> 	Defective scanner controller board.	Replace the scanner controller board.	Replace scanner controller board.
	Defective copy processor.	Replace the copy processor board.	Replace the copy processor EIO.
<p>Horizontal lines</p> 	Defective scanner controller board.	Replace the scanner controller board.	Replace scanner controller board.
	Defective copy processor.	Replace the copy processor board.	Replace the copy processor EIO.
<p>Stretched/shrunk image</p> 	<p>N/A This should be scan location specific.</p>		
<p>Skewed image</p> 	<p>N/A This should be scan location specific.</p>		
<p>Overall copy-image accuracy (CLJ 9500mfp only)</p>	The colors on the copy do not match the colors on the original.	N/A	Some originals are difficult to reproduce. Make sure that the correct copy settings are being used for the type of original that is being copied. See "Color copy settings (HP LaserJet 9500mfp)" on page 40.

**Table 71. All scan locations (continued)**

Defect	Cause	Solution LJ 9000mfp/9000Lmfp	Solution LJ 9040mfp/9050mfp/9500mfp
Moire patter	The default copy settings might not be optimal for some half-toned images.	N/A	Copy the original using the PHOTO copy setting (use the control panel to gain access to the <b>DESCRIBE ORIGINAL, PAGE CONTENT</b> screen). See “Color copy settings (HP LaserJet 9500mfp)” on page 40.

# Scanner controller PCB

**Note**

The label in this section is for the HP LaserJet 9000mfp/9000Lmfp. The label might look different than the sample below depending on the MFP that you have.

The MFP scan engine calibrations are stored on the scanner controller board (SCB). If the SCB needs to be replaced, back up the calibrations by copying the settings to the hard drive. To copy the settings:

- 1 Touch MENU.
- 2 Touch SERVICE MENU.
- 3 Touch SCANNER SETTINGS.
- 4 Touch SAVE SETTINGS.

To write the stored values back to the new SCB:

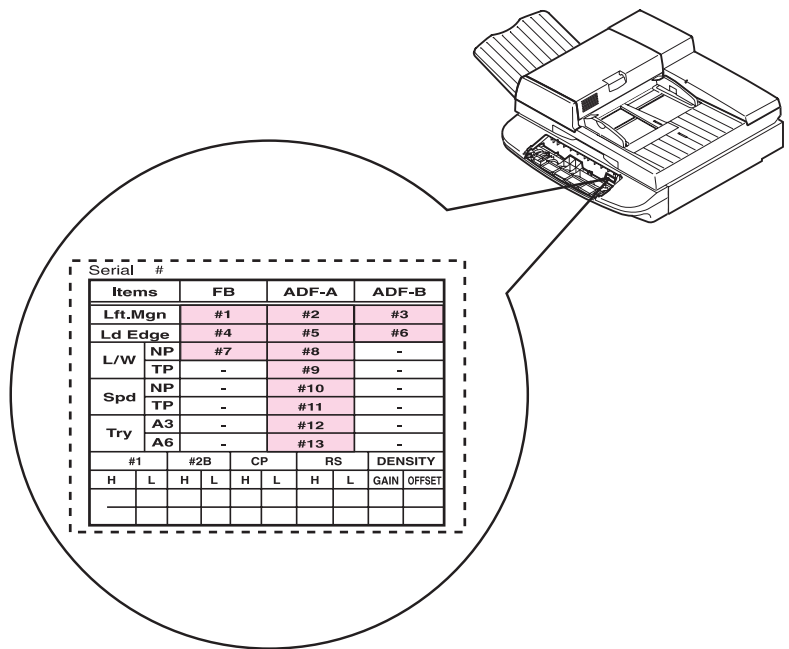
- 1 Touch MENU.
- 2 Touch SERVICE MENU.
- 3 Touch SCANNER SETTINGS.
- 4 Touch RESTORE SETTINGS.

**Note**

HP recommends backing up the calibration values before performing any of the scan engine calibrations. If you experience a problem while performing a calibration, restore the old values and start over again.

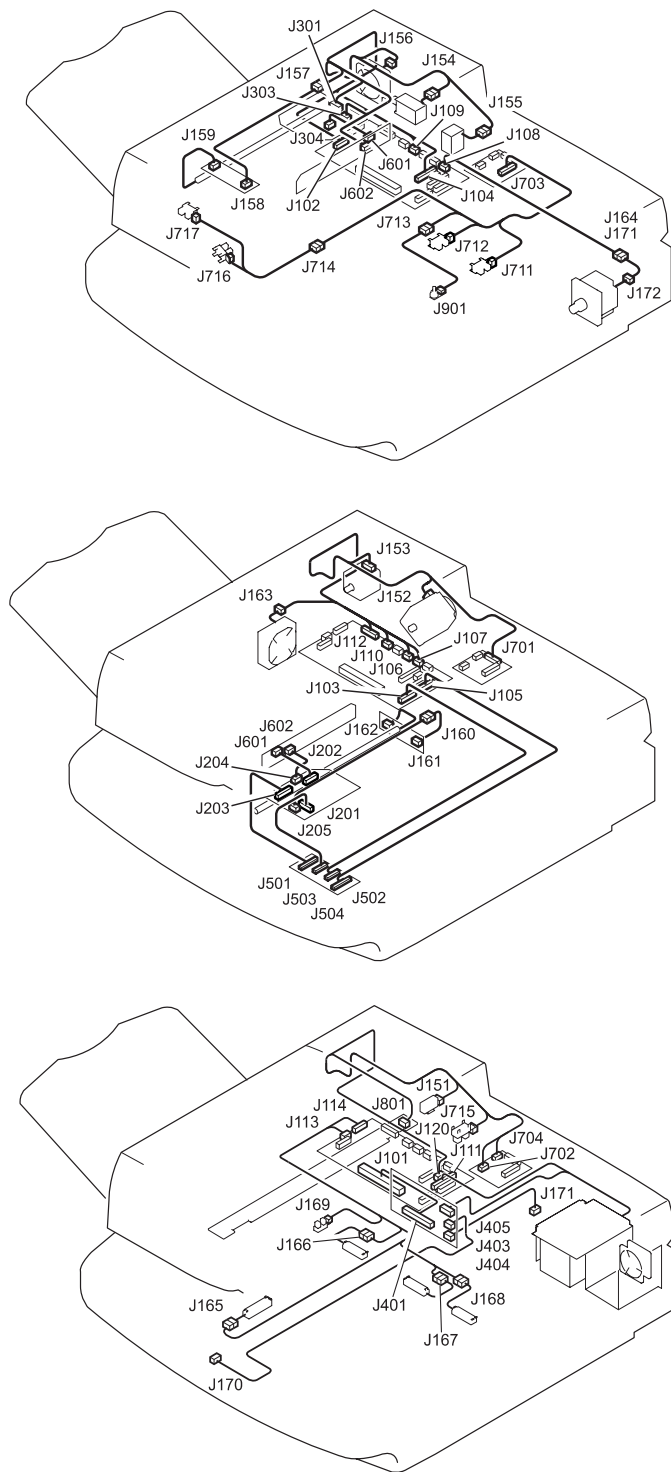
**Note**

A service label located inside the flatbed lower front cover is a hard copy backup of the calibration values. If you enter new calibration values, download the file SERVICE LABELS and record the new values on the label. Tape the new label over the old label.



**Figure 228.** Scanner controller PCB (HP LaserJet 9000mfp/9000Lmfp shown)

# Connector locations



**Figure 229.** Connector locations

## Electrical structure

**Table 72. Sensors**

<b>Sensor</b>	<b>Location</b>	<b>Type</b>	<b>Qty</b>
ADF angle (detects when ADF is 30°)	ADF	optical/flag	1
ADF document length detection	ADF	optical/flag	2
ADF feeder switch	ADF feeder	optical/flag	1
ADF open/closed	ADF	optical/flag	1
Document detection	flatbed	optical/reflective	1
Document size	flatbed	optical/reflective	3
Document width	ADF	potentiometer	1
Flatbed carriage home position	flatbed	optical/flag	1
Paper loaded (empty)	ADF feeder	optical/flag	1
Pickup roller home position	ADF feeder	optical/flag	1
Registration detections	ADF feeder	optical flag	1
Skew detection	ADF feeder	optical flag	2
Timing	ADF feeder	optical/flag	1







# 8

# Parts and diagrams

## Chapter contents

Introduction . . . . .	316
Ordering parts . . . . .	316
Consumables (HP LJ 9000mfp/9000Lmfp9040mfp/9050mfp) . . . . .	317
Consumables (HP CLJ 9500mfp) . . . . .	322
Common hardware . . . . .	326
Illustrations and parts lists . . . . .	327
MFP system assembly . . . . .	328
External panels and covers . . . . .	329
Flatbed scanner assembly . . . . .	332
Flatbed optical assembly . . . . .	337
ADF scanner assembly . . . . .	339
Paper pickup assembly . . . . .	342
ADF main assembly . . . . .	347
ADF optical assembly . . . . .	350
PCB assemblies . . . . .	352
Alphabetical parts list . . . . .	353
Numerical parts list . . . . .	358

# Introduction

The figures in this chapter illustrate the major subassemblies in the printer and their component parts. A table accompanies each exploded-view diagram. Each table lists the item number for the replaceable part, the associated part number for the item, the quantity, and a description of the part.

---

**Note**

---

When looking for a part number, pay careful attention to the voltage listed in the description column to ensure that the part number selected is for the correct printer model.

## Ordering parts

All standard part numbers listed are stocked and can be ordered from HP's Customer Services and Support Organization.

Consumables and accessories like those listed in table 73 can be ordered from the Hewlett-Packard Company.

## Consumables (HP LJ 9000mfp/9000Lmfp9040mfp/9050mfp)

### Note

\* These products come standard with the MFP.

\*\* One of these devices must be installed in order to operate the MFP.

**Table 73. Consumables, supplies, accessories, FRUs, and documentation**

Product number	Service number	Exchange number	Description	Printer
<b>Consumables</b>				
C8543X		C8519-69009	Print cartridge	
C8085A	C8085-60541		Staple cartridge (3,000-sheet stapler/stacker)	
C8088B	C8088-60541		Staple cartridge (multifunction finisher)	
<b>Supplies</b>				
C9152A	C9152-67904	C9152-69004	PM kit/110 V	
C9153A	C9153-67904	C9153-69004	PM kit/220 V	
<b>FRUs</b>				
C7860A	C8519-67901	C8519-69001	Formatter assembly	HP LaserJet 9000mfp/9000Lmfp
	Q3726-67905		Formatter assembly ( <b>Note:</b> Do <i>not</i> replace the formatter and the CompactFlash firmware at the same time)	HP LaserJet 9040mfp and 9050mfp
RG5-5750-210CN		C8519-69031	Fuser assembly, 110 V	
RG5-5751-210CN		C8519-69032	Fuser assembly, 220 V	
RG5-5681-030CN			Paper input unit (PIU)	
RG5-5778-120CN		C8519-69028	DC controller	HP LaserJet 9000mfp/9000Lmfp
RG5-7780-000CN			DC controller	HP LaserJet 9000mfp/9000Lmfp/9040mfp/9050mfp
RG5-5728-050CN		C8519-69015	High-voltage power supply	
RG5-5730-000CN		C8519-69007	Low-voltage power supply, 110 V	HP LaserJet 9000mfp/9000Lmfp/9040mfp/9050mfp
RG5-7778-000CN			Low-voltage power supply, 110 V	HP LaserJet 9000mfp/9000Lmfp/9040mfp/9050mfp
RG5-5731-000CN			Low-voltage power supply, 220 V	HP LaserJet 9000mfp/9000Lmfp/9040mfp/9050mfp
RG5-7779-000CN			Low-voltage power supply, 220 V	HP LaserJet 9000mfp/9000Lmfp/9040mfp/9050mfp

**Table 73. Consumables, supplies, accessories, FRUs, and documentation (continued)**

Product number	Service number	Exchange number	Description	Printer
	5851-1838		Control panel assembly	HP LaserJet 9040mfp/9050mfp
	RG5-5734-020		Control panel assembly	HP LaserJet 9000mfp/9000Lmfp
Q2635-67912			Firmware compact flash	HP LaserJet 9050
RG5-5663-000CN			Registration assembly	
	RB2-6501-000CN (LJ 9000mfp/9000Lmfp) right RB2-6500-000CN (LJ 9000mfp/9000Lmfp) left Q3726-60105 (LJ 9040mfp/9050mfp)		Control panel overlay English	See service part number
	5969-9741 (LJ 9000mfp/9000Lmfp) Q3726-60106 (LJ 9040mfp/9050mfp)		Control panel overlay French (European)	See service part number
	5969-9472 (LJ 9000mfp/9000Lmfp) Q3726-60107 (LJ 9040mfp/9050mfp)		Control panel overlay Italian	See service part number
	5969-9473 (LJ 9000mfp/9000Lmfp) Q3726-60108 (LJ 9040mfp/9050mfp)		Control panel overlay German	See service part number
	5969-9474 (LJ 9000mfp/9000Lmfp) Q3726-60109 (LJ 9040mfp/9050mfp)		Control panel overlay Spanish (Castilian)	See service part number
	5969-9475 (LJ 9000mfp/9000Lmfp) Q3726-60110 (LJ 9040mfp/9050mfp)		Control panel overlay Dutch	See service part number
	5969-9476 (LJ 9000mfp/9000Lmfp) Q3726-60111 (LJ 9040mfp/9050mfp)		Control panel overlay Portuguese (Brazilian)	See service part number
	5969-9477 (LJ 9000mfp/9000Lmfp) Q3726-60112 (LJ 9040mfp/9050mfp)		Control panel overlay Norwegian	See service part number
	5969-9478 (LJ 9000mfp/9000Lmfp) Q3726-60113 (LJ 9040mfp/9050mfp)		Control panel overlay Swedish	See service part number
	5969-9479 (LJ 9000mfp/9000Lmfp) Q3726-60114 (LJ 9040mfp/9050mfp)		Control panel overlay Finnish	See service part number
	5969-9480 (LJ 9000mfp/9000Lmfp) Q3726-60115 (LJ 9040mfp/9050mfp)		Control panel overlay Danish	See service part number
	Q3726-60116 (LJ 9040mfp/9050mfp)		Control panel overlay Polish	See service part number
	5969-9482 (LJ 9000mfp/9000Lmfp) Q3726-60117 (LJ 9040mfp/9050mfp)		Control panel overlay Russian	See service part number
	Q3726-60118 (LJ 9040mfp/9050mfp)		Control panel overlay Czech	See service part number
	Q3726-60119 (LJ 9040mfp/9050mfp)		Control panel overlay Hungarian	See service part number
	5969-9489 (LJ 9000mfp/9000Lmfp) Q3726-60120 (LJ 9040mfp/9050mfp)		Control panel overlay Chinese, traditional	See service part number
	5969-9483 (LJ 9000mfp/9000Lmfp) Q3726-60121 (LJ 9040mfp/9050mfp)		Control panel overlay Chinese, simplified	See service part number
	Q3726-60122 (LJ 9040mfp/9050mfp)		Control panel overlay Korean	See service part number
	Q3726-60123 (LJ 9040mfp/9050mfp)		Control panel overlay Japanese	See service part number
	Q3726-60124 (LJ 9040mfp/9050mfp)		Control panel overlay Turkish	See service part number

**Table 73. Consumables, supplies, accessories, FRUs, and documentation (continued)**

Product number	Service number	Exchange number	Description	Printer
	Q3726-60125 (LJ 9040mfp/9050mfp)		Control panel overlay Hebrew	See service part number
	Q3726-60126 (LJ 9040mfp/9050mfp)		Control panel overlay Greek	See service part number
	5969-9492 (LJ 9000mfp/9000Lmfp) Q3726-60127 (LJ 9040mfp/9050mfp)		Control panel overlay Arabic	See service part number
	Q3726-60123 (LJ 9040mfp/9050mfp)		Control panel overlay Thai	See service part number
<b>Accessories</b>				
			Blank 16MB flash DIMM	
C9147A	C9147-67908	C9147-69019	16 MB flash firmware DIMM	HP LaserJet 9000mfp/9000Lmfp
C7843A	C7843-67901		16 MB DIMM	HP LaserJet 9000mfp/9000Lmfp
C7845A	C7845-67901		32 MB DIMM	HP LaserJet 9000mfp/9000Lmfp
Q1887A	C7846-67901		64 MB DIMM	HP LaserJet 9000mfp/9000Lmfp
C9121A	C9121-67901		128 MB DIMM	HP LaserJet 9000mfp/9000Lmfp
	Q3982-67951		32MB DDR DIMM	HP LaserJet 9050 series only
	Q2625-67951		64MB DDR DIMM	HP LaserJet 9050 series only
	Q2626-67951		128MB DDR DIMM	HP LaserJet 9050 series only
	Q2627-67951		256MB DDR DIMM	HP LaserJet 9050 series only
Q2628A	Q2628-67951		512MB DDR DIMM	HP LaserJet 9050 series only
C4103A	C4103-67901		HP Fast InfraRed Connect pod	HP LaserJet 9000mfp/9000Lmfp
C4293A			Font DIMM—simplified Chinese	HP LaserJet 9000mfp/9000Lmfp
C4292A			Font DIMM—traditional Chinese	HP LaserJet 9000mfp/9000Lmfp
J6054B	J6054-61031	J6054-69031	Hard disk	HP LaserJet 9000mfp/9000Lmfp
J6073A	J6073-61011 new or replacement	J6073-69011 exchange	Hard disk	HP LaserJet 9040mfp/9050mfp
J4169A	J4169-61001	J4169-69001	HP Jetdirect 610N Fast Ethernet (10/100 Base-TX)	
J4135A	J4135-61001		HP Jetdirect Connectivity (USB)	
C8568A	C8568-67902		Tray 1	
C8531A	C8531-67902		2,000-sheet feeder (tray 4)	

**Table 73. Consumables, supplies, accessories, FRUs, and documentation (continued)**

Product number	Service number	Exchange number	Description	Printer
RG5-6212-300CN			2,000-sheet feeder (tray 4) cassette only	
RG5-6225-050CN			Vertical transfer assembly	
RG5-6228-040CN			Paper deck drive assembly	
RG5-6208-150CN		C8531-69013	Paper pickup assembly	
C8085A			3,000-sheet stapler/stacker	
C8088B			Multifunction finisher	
Q8532A			8-bin mailbox	HP LaserJet 9050 series only
C8532A	C8532-67902		Duplexer	
<b>Documentation</b>				
	5963-7863		<i>HP LaserJet Printer Family Print Media Guide</i>	
	5969-6818		<i>HP Jetdirect Print Server Administrator's Guide</i>	
	5969-3412		<i>HP Jetdirect Print Server Jetadmin Setup Guide</i>	
	Q5693-90002		<i>Paper Handling Accessories Service Addendum</i>	
	C8519-90901		<i>HP LaserJet 9000 Start Guide—U.S.</i>	
	C8519-90902		<i>HP LaserJet 9000 Start Guide—Americas</i>	
	C8519-90903		<i>HP LaserJet 9000 Start Guide—West Europe</i>	
	C8519-90904		<i>HP LaserJet 9000 Start Guide—North Europe</i>	
	C8519-90905		<i>HP LaserJet 9000 Start Guide—East Europe</i>	
	C8519-90906		<i>HP LaserJet 9000 Start Guide—Asia</i>	
			<a href="http://www.hp.com/support/lj9000">www.hp.com/support/lj9000</a>	
			<i>HP LaserJet 9000 Use Guide</i>	
	Q3721-90906		<i>HP LaserJet 9050 Use Guide</i>	
	Q3721-90931		<i>HP LaserJet 9000 and 9050 Series printers Service Guide</i>	
	C8532-90901		<i>HP Duplexer Install Guide</i>	
	C8568-90901		<i>HP Tray 1 Install Guide</i>	
	C8531-90901		<i>HP 2,000-sheet feeder Install Guide</i>	
	C8084-90900		<i>HP Stapler/stacker and Stacker Install Guide</i>	
	C8088-90903		<i>HP Multifunction Finisher Install Guide</i>	

**Table 73. Consumables, supplies, accessories, FRUs, and documentation (continued)**

<b>Product number</b>	<b>Service number</b>	<b>Exchange number</b>	<b>Description</b>	<b>Printer</b>
	C8088-90902		<i>HP Multifunction Finisher Service Guide</i>	
	C8088-90901		<i>HP Multifunction Finisher Use Guide</i>	
	C8519-60102		<i>HP LaserJet 9000 Series Printer Software CD-ROM—Americas</i>	
	C8519-60104		<i>HP LaserJet 9000 Series Printer Software CD-ROM—Europe</i>	
	C8519-60105		<i>HP LaserJet 9000 Series Printer Software CD-ROM—Asia</i>	
	C8519-60106		<i>HP LaserJet 9000 Series Printer Service CD-ROM (English version)</i>	
	C9152-90901		PM kit installation guide	

## Consumables (HP CLJ 9500mfp)

**Table 74. Kits and supplies**

Item	Product Number	Service part-number	Description
Print cartridge, black	C8550A	C8550-67901	Replacement print cartridge
Print cartridge, cyan	C8551A	C8551-67901	Replacement print cartridge
Print cartridge, yellow	C8552A	C8552-67901	Replacement print cartridge
Print cartridge, magenta	C8553A	C8553-67901	Replacement print cartridge
Image drum, black	C8560A	C8560-67901	Replacement image drum
Image drum, cyan	C8561A	C8561-67901	Replacement image drum
Image drum, yellow	C8562A	C8562-67901	Replacement image drum
Image drum, magenta	C8563A	C8563-67901	Replacement image drum
Image transfer Kit	C8555A	C8555-67901	One image transfer belt, one image transfer roller, nine paper rollers, and one ozone filter
Image cleaning kit	C8554A	C8554-67901	One air filter, one transfer cleaner, and one toner collection bottle
Fuser kit	C8556A	RG5-6098-110CN new C8546-69007 exchange	One fuser assembly

**Table 75. Accessories, exchange parts, and documentation**

Item	Product number	Service part-number	Description
Staple cartridge for stapler/stacker	C8091A	C8085-67901	Replacement cartridge
Staple cartridge for multifunction finisher	C8092A	C8088-60541	Replacement cartridge
Intermediate transfer belt (ITB) assembly	No product number	RG5-6400-030CN new C8546-69002 exchange	Entire assembly
Cartridge drive assembly	No product number.	RG5-6188-030CN new C8546-69006 exchange	Entire assembly
Power supply 110 V	No product number.	C8546-69003 exchange	PCA assembly
Power supply 220 V	No product number.	C8546-69004 exchange	PCA assembly
Formatter assembly (LJ 9500)	No product number.	C8546-67911 new C8546-69001 exchange	Does not include memory, firmware, or EIO card
Formatter assembly (LJ9500mfp)	Q5915A	Q5915-67901 new Q5915-69001 exchange	Does not include memory, firmware, or EIO card
32 MB compact flash (MFP firmware)	No product number.	Q2635-67909	Flash firmware, compact flash for the MFP
512 MB RAM DIMM	No product number.	Q2632-67951	DIMM 512 MB DDR 200-pin SDRAM
DC controller	No product number.	C8546-67906 new C8546-69005 exchange	PCA
Control Panel	No product number.	5851-1838	Control panel display
Control panel overlay	No product number.	Q3726-60105 (LJ 9500mfp)	English

**Table 75. Accessories, exchange parts, and documentation (continued)**

Item	Product number	Service part-number	Description
Control panel overlay	No product number.	Q3726-60106 (LJ 9500mfp)	French (European)
Control panel overlay	No product number.	Q3726-60107 (LJ 9500mfp)	Italian
Control panel overlay	No product number.	Q3726-60108 (LJ 9500mfp)	German
Control panel overlay	No product number.	Q3726-60109 (LJ 9500mfp)	Spanish (Castilian)
Control panel overlay	No product number.	Q3726-60110 (LJ 9500mfp)	Dutch
Control panel overlay	No product number.	Q3726-60111 (LJ 9500mfp)	Portuguese (Brazilian)
Control panel overlay	No product number.	Q3726-60112 (LJ 9500mfp)	Norwegian
Control panel overlay	No product number.	Q3726-60113 (LJ 9500mfp)	Swedish
Control panel overlay	No product number.	Q3726-60114 (LJ 9500mfp)	Finnish
Control panel overlay	No product number.	Q3726-60115 (LJ 9500mfp)	Danish
Control panel overlay	No product number.	Q3726-60116 (LJ 9500mfp)	Polish
Control panel overlay	No product number.	Q3726-60117 (LJ 9500mfp)	Russian
Control panel overlay	No product number.	Q3726-60118 (LJ 9500mfp)	Czech
Control panel overlay	No product number.	Q3726-60119 (LJ 9500mfp)	Hungarian
Control panel overlay	No product number.	Q3726-60120 (LJ 9500mfp)	Chinese, traditional
Control panel overlay	No product number.	Q3726-60121 (LJ 9500mfp)	Chinese, simplified
Control panel overlay	No product number.	Q3726-60122 (LJ 9500mfp)	Korean
Control panel overlay	No product number.	Q3726-60123 (LJ 9500mfp)	Japanese
Control panel overlay	No product number.	Q3726-60124 (LJ 9500mfp)	Turkish
Control panel overlay	No product number.	Q3726-60125 (LJ 9500mfp)	Hebrew
Control panel overlay	No product number.	Q3726-60126 (LJ 9500mfp)	Greek
Control panel overlay	No product number.	Q3726-60127 (LJ 9500mfp)	Arabic
Control panel overlay	No product number.	Q3726-60123 (LJ 9500mfp)	Thai
HP Fast InfaRed Connect Pod	C4103A	C4103-67901	Wireless printing device
Hard disk	J6073A	J6073-69011 (exchange) J6073-61011 (new or replacement)	20 GB hard drive 20 GB hard drive
HP Jetdirect 620 Fast Ethernet (10/100 Base-TX) (LJ 9500mfp)	No product number.	J7934-61001 new J7934-69001 exchange	Ethernet EIO card
PCA Fax modem card	No product number.	Q3701-60002	Fax
HP Jetdirect Connectivity (USB)	J4135A	J4135-61001	USB EIO card
3,000-sheet stacker	C8084A	Not orderable	Finishing device
3,000-sheet stapler/stacker	C8085A	Not orderable	Finishing device
Multifunction finisher	C8088A	C8088-60500 new C8088-69500 exchange	Finishing device
Duplexer	C9674A	C9674-67901 new C9674-69001 exchange	Required for two-sided printing
Pedestal (LJ 9500mfp)	No product number.	C8546-67909 new C8546-69008 exchange	Stand with casters.
2,000-sheet side-input feeder tray 4 for the LJ 9500mfp	No product number.	Q1891-67901 new C8549-69001 exchange	High capacity tray.

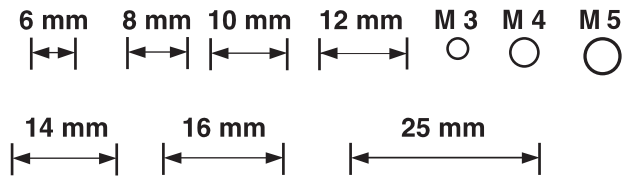
**Table 75. Accessories, exchange parts, and documentation (continued)**

Item	Product number	Service part-number	Description
Discharge comb cleaning brush	No product number.	RB2-7615-000CN	Used to clean the transfer cleaner corona wire
Cable, power jumper	No product number.	C8546-60104	Required for the LJ 9500mfp.
Cable, fax custom	No product number.	C8546-60108	Fax cable, extension or formatter.
Power cord	No product number.	5181-3530	United States, Mexico, Brazil, Canada, Taiwan
Power cord	No product number.	8120-6800	Israel
Power cord	No product number.	8120-6811	Korea, Turkey, Portugal, Germany, Spain, France, Netherlands, Norway, Sweden, Finland, Italy, Russia, Czech Republic, Hungary, Poland, Jordan, Lebanon, North Africa
Power cord	No product number.	8120-6812	Greece
Power cord	No product number.	8120-6813	South Africa
Power cord	No product number.	8120-6814	Denmark
Power cord	No product number.	8120-6815	Switzerland
Power cord	No product number.	8120-8706	United Kingdom, Hong Kong, Singapore, Malaysia
Power cord	No product number.	8120-8707	China
Power cord	No product number.	8121-0780	India
Copy connect cable (scanner) (LJ 9500mfp)	No product number.	C8549-60105	38 inch cable between the scanner and the print engine
Copy processor EIO (LJ 9500mfp)	No product number.	Q2679-67901	EIO copy processor board
Copy connect board assembly (in the scanner)	No product number.	Q3650-60001	PCA-LVDS adapter (in the scanner)
Cable, copy connect	No product number.	C8549-60105	Cable from the formatter to the scanner (30 inches)
Clamp, copy connect cable	No product number.	5851-1964	Cable retainer clamp
Phone cord	No product number.	8121-0811	United States, Canada, Poland, Russia, Spain, Portugal, Greece, France, Mexico, Brazil
Phone cord	No product number.	8120-8911	Denmark
Phone cord	No product number.	8120-8912	Germany
Phone cord	No product number.	8120-8914	Italy
Phone cord	No product number.	8120-8915	Netherlands
Phone cord	No product number.	8120-8916	Norway
Phone cord	No product number.	8120-8917	South Africa
Phone cord	No product number.	8120-8920	United Kingdom
Phone cord	No product number.	8120-8921	Hong Kong
Phone cord	No product number.	8120-8922	Czech Republic
Phone cord	No product number.	8120-8923	France
Service manual bundle	No product number.	C8549-99001	Printer, finishing devices and side-input tray 4

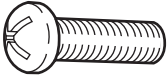

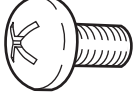
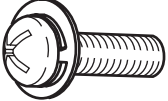
**Table 75. Accessories, exchange parts, and documentation (continued)**

Item	Product number	Service part-number	Description
Training kit for HP Color LaserJet 9500/9500mfp printer	No product number.	C8546-60109	CD- based service training materials
User guide	Electronic versions ready to print at: <a href="http://www.hp.com/support/lj9500">http://www.hp.com/support/lj9500</a>		Mini-manual that goes inside of the right door of the HP Color LaserJet 9500 series printer
HP Color LaserJet 9500 Series Printer and 9500mfp Use guide and User reference guide	Electronic versions ready to print at: <a href="http://www.hp.com/support/lj9500">www.hp.com/support/lj9500</a> or <a href="http://www.hp.com/support/clj9500mfp">www.hp.com/support/clj9500mfp</a>		Electronic versions of the user guide and the user reference guide.

## Common hardware



**Table 76. Hardware table**

Example	Description	Sizes	Uses
	Screw	M3 by 6 mm M3 by 8 mm M4 by 8 mm M4 by 10 mm	
	Screw, tapping	M3 by 6 mm M3 by 8 mm M3 by 30 mm M4 by 6 mm M4 by 12 mm	To hold plastic to metal (excluding the MFP control panel)
	Screw, pan head	M3 by 6 mm	To hold plastic to plastic
	Screw, w/washer	M3 by 6 mm M3 by 8 mm M3 by 7 mm M4 by 6 mm M4 by 12 mm	To hold plastic to metal (excluding the covers)

**Table 77. Common torque values**

Material	HP recommended torque value
Plastic to metal	5.5 lb-inch
Metal to metal	10 lb-inch
PCBA	5.5 lb-inch
Plastic to plastic	5.5 lb-inch

## Illustrations and parts lists

The following illustration and parts tables show the field replaceable units (FRUs). Two tables at the end of this chapter list all of the parts shown in this chapter in alphabetical (by part name) and numerical (by part number) order. Both tables also provide the figure in this chapter that shows the part.

---

**Note**

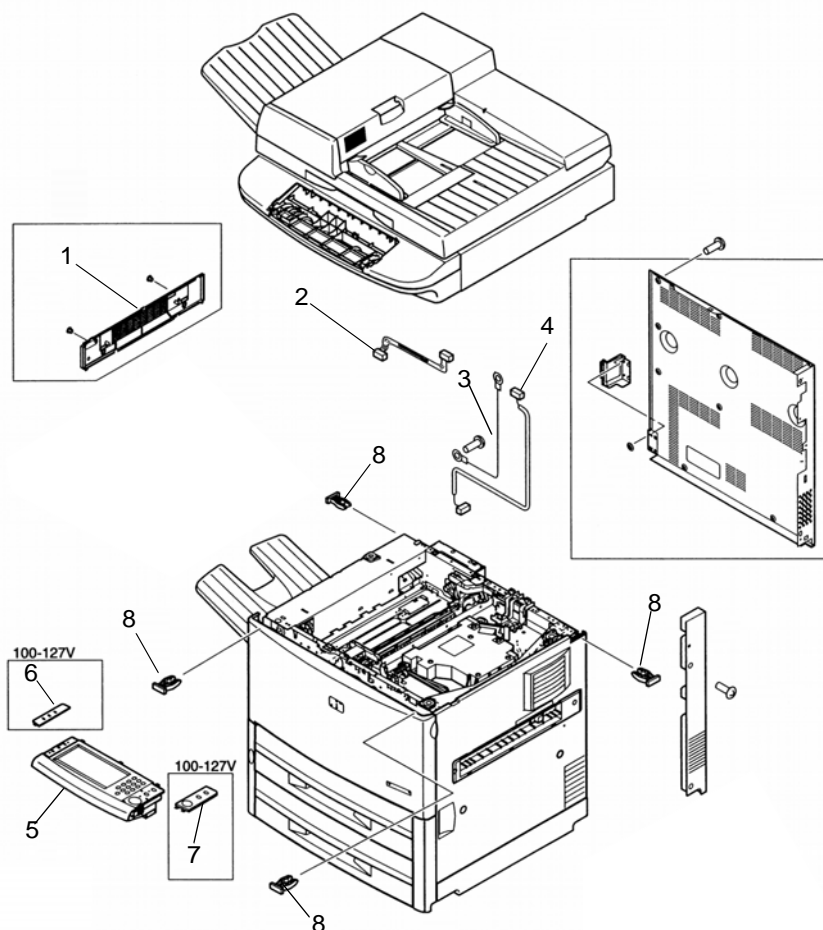
For print engine parts not listed in this manual, see the *HP LaserJet 9000 and 9050 Printer Service Manual* or the *HP Color LaserJet 9500/9500mfp Print Engine Service Manual*.

---

**Note**

Parts that have no part number listed are not FRUs and cannot be ordered.

## MFP system assembly

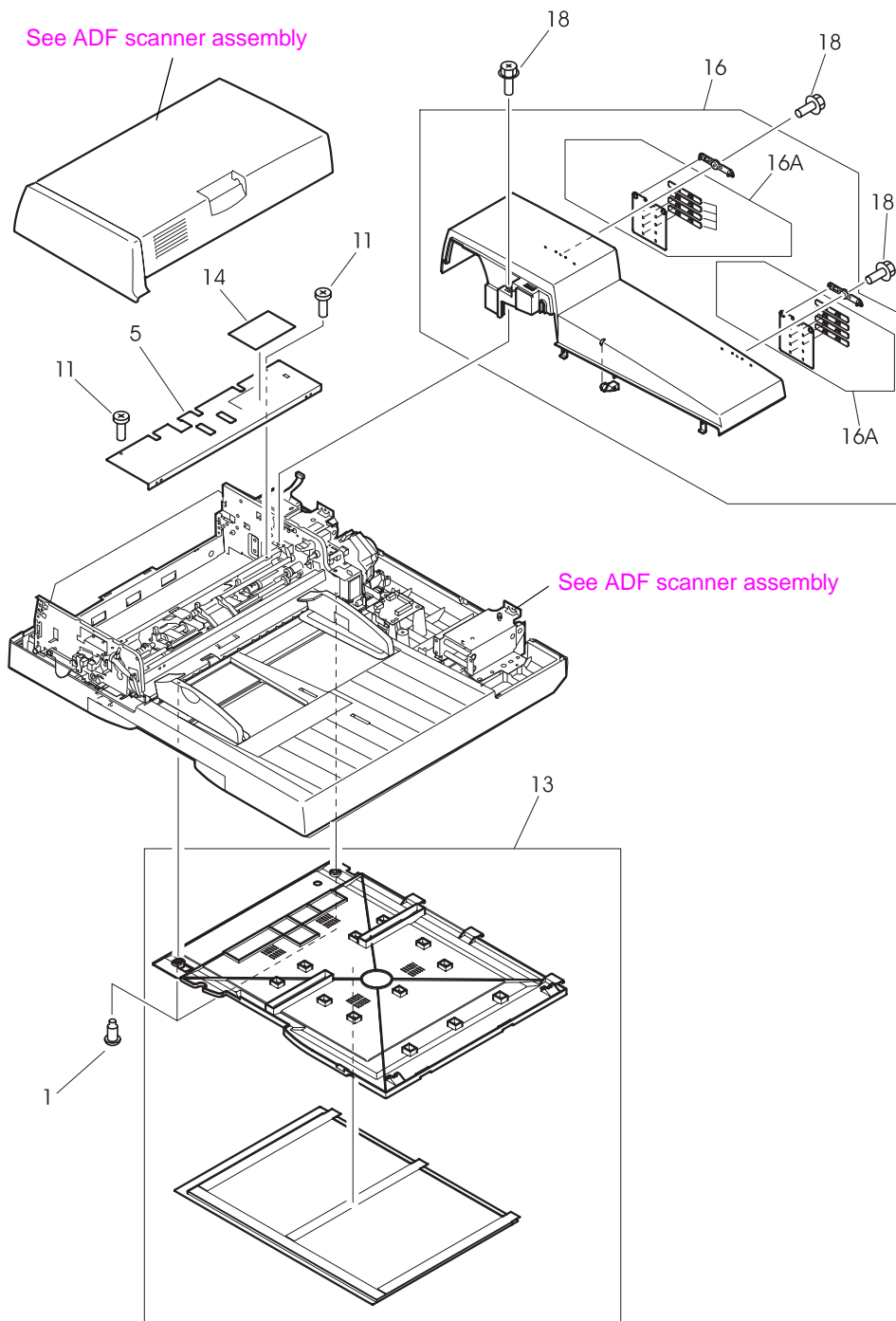


**Figure 232.** MFP system assembly (HP LJ 9000mfp/9000Lmfp/9040mfp/9050mfp shown)

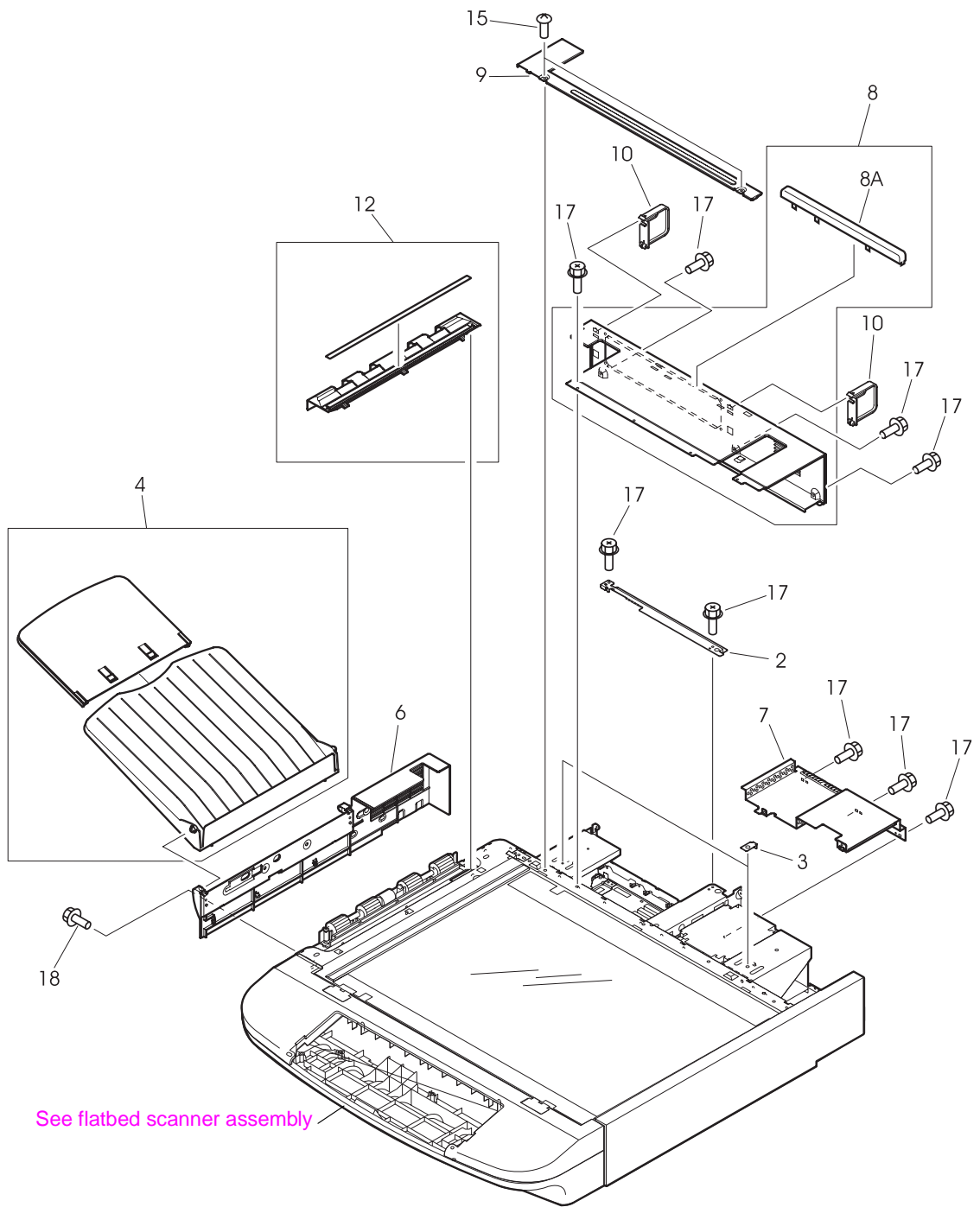
**Table 78.** MFP system assembly

Ref	Description	HP LJ 9000mfp HP LJ 9000Lmfp Part number	HP LJ 9040mfp HP LJ 9050mfp Part number	HP LJ 9500mfp Part number	Qty
1	Left upper cover assembly	RG5-5706-000CN	RG5-5706-000CN	RB2-7336-000CN	1
2	Control panel cable	RG5-5752-000CN	RG5-5752-000CN	RG5-5752-000CN	1
3	Grounding cable	RG5-5736-000CN	RG5-5736-020CN	RG5-5992-000CN	1
4	Power supply cable (HP LJ 9000mfp/ 9000Lmfp/9040mfp/9050mfp) AC cable (HP CLJ 9500mfp)	RG5-5735-000CN	RG5-5735-000CN	RG5-5991-000CN	1
5	Control panel assembly	RG5-5734-020CN	5851-1838	5851-1838	1
6	Control panel overlay left	See Table 73.	See Table 73.	See Table 75.	1
7	Control panel overlay right	See Table 73.	See Table 73.	See Table 75.	1
8	Holder, lock	RB2-6495-000CN	RB2-6495-000CN	RB2-6495-000CN	4

## External panels and covers



**Figure 233.** External panels and covers (1 of 2)



**Figure 234.** External panels and covers (2 of 2)

**Table 79. External panels and covers**

Ref	Description	HP LJ 9000mfp HP LJ 9000Lmfp Part number	HP LJ 9040mfp HP LJ 9050mfp Part number	HP LJ 9500mfp Part number	Qty
1; Figure 233.	Screw, stepped M4X3.2	Not orderable	Not orderable	Not orderable	2
2; Figure 234.	Plate, crossmember	Not orderable	Not orderable	Not orderable	1
3; Figure 234.	Bracket, mount	Not orderable	Not orderable	Not orderable	2
4; Figure 234.	ADF output tray <sup>1</sup> Delivery tray assembly <sup>2</sup>	RG5-6316-000CN	RG5-6316-000CN	RG5-6316-000CN	1
5; Figure 233.	Plate, cover upper	Not orderable	Not orderable	Not orderable	1
6; Figure 234.	Cover, flatbed left <sup>1</sup> Cover, left <sup>2</sup>	RB2-8054-000CN	RB2-8054-000CN	RB2-8054-000CN	1
7; Figure 234.	Plate, protect	Not orderable	Not orderable	Not orderable	1
8; Figure 234.	Rear cover assembly	Not orderable	Not orderable	Not orderable	1
8A; Figure 234.	Holder, document stop	Not orderable	Not orderable	Not orderable	1
9; Figure 234.	Plate, rear sub	Not orderable	Not orderable	Not orderable	1
10; Figure 234.	CPB protectors <sup>1</sup> Cover, connector <sup>2</sup>	RB2-8060-000CN	RB2-8060-000CN	RB2-8060-000CN	2
11; Figure 233.	Screw, M3X5	Not orderable	Not orderable	Not orderable	4
12; Figure 234.	Cover, lower delivery roller <sup>1</sup> Guide, delivery unit <sup>2</sup>	RF5-3674-000CN	RF5-3674-000CN	RF5-3674-000CN	1
13; Figure 233.	Cover whiteboard <sup>1</sup> Cover, copyboard unit <sup>2</sup>	RF5-3695-000CN	RF5-3695-000CN	RF5-3695-000CN	1
14; Figure 233.	Label, jam clearing	Not orderable	Not orderable	Not orderable	1
15; Figure 234.	Screw, TP M4X8	Not orderable	Not orderable	Not orderable	2
16; Figure 234.	ADF back cover assembly <sup>1</sup> ADF rear cover assembly <sup>2</sup>	RG5-6315-000CN	RG5-6315-000CN	RG5-6315-000CN	1
16A; Figure 234.	Hinge cover assembly	RG5-6317-000CN	RG5-6317-000CN	RG5-6317-000CN	2
17; Figure 234.	Screw, RS M3X6	Not orderable	Not orderable	Not orderable	16
18; Figure 234.	Screw, RS M3X8	Not orderable	Not orderable	Not orderable	7
<sup>1</sup> HP LaserJet 9000mfp/9000Lmfp component description <sup>2</sup> HP LaserJet 9040mfp/9050mfp/9500mfp component description					

# Flatbed scanner assembly

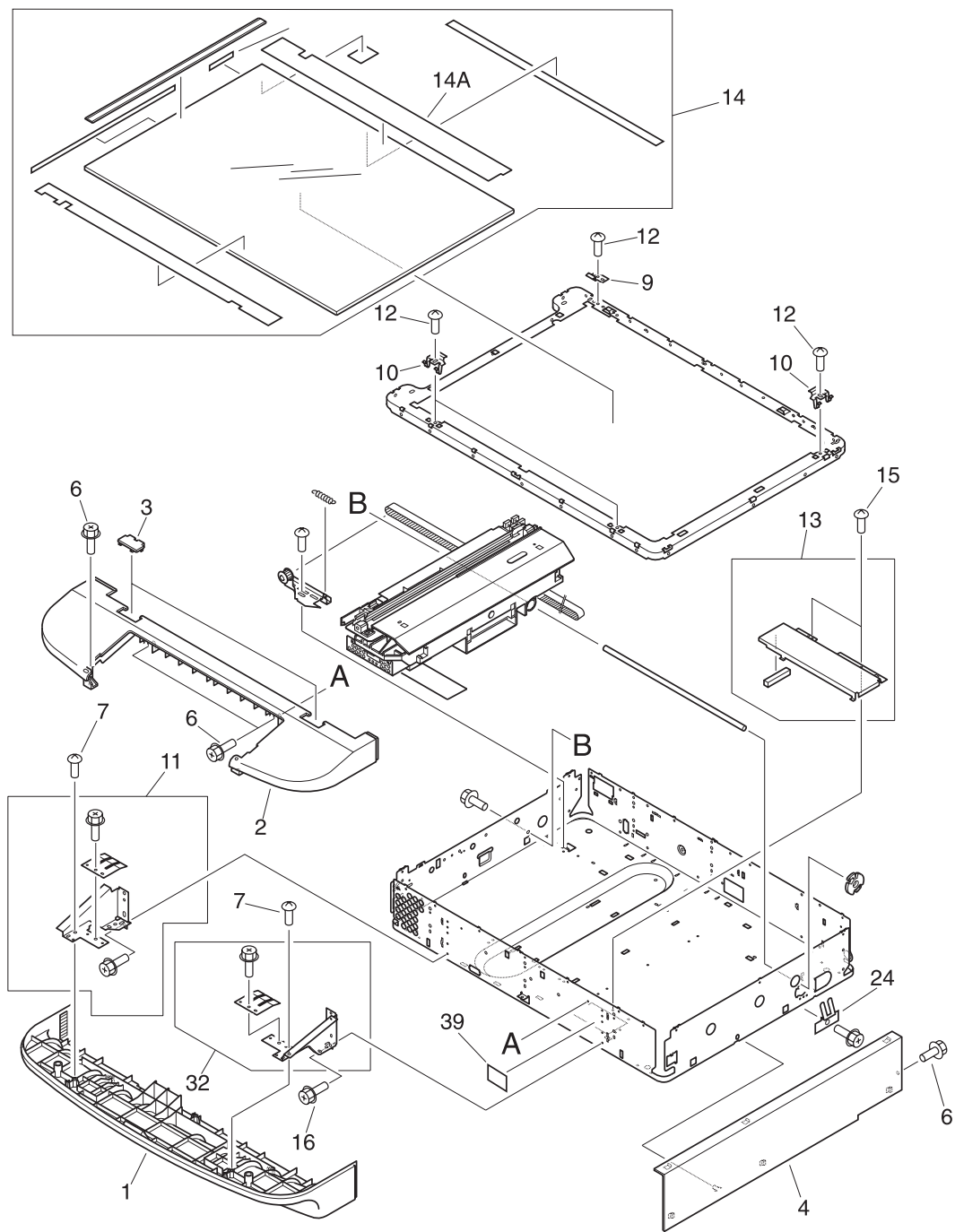
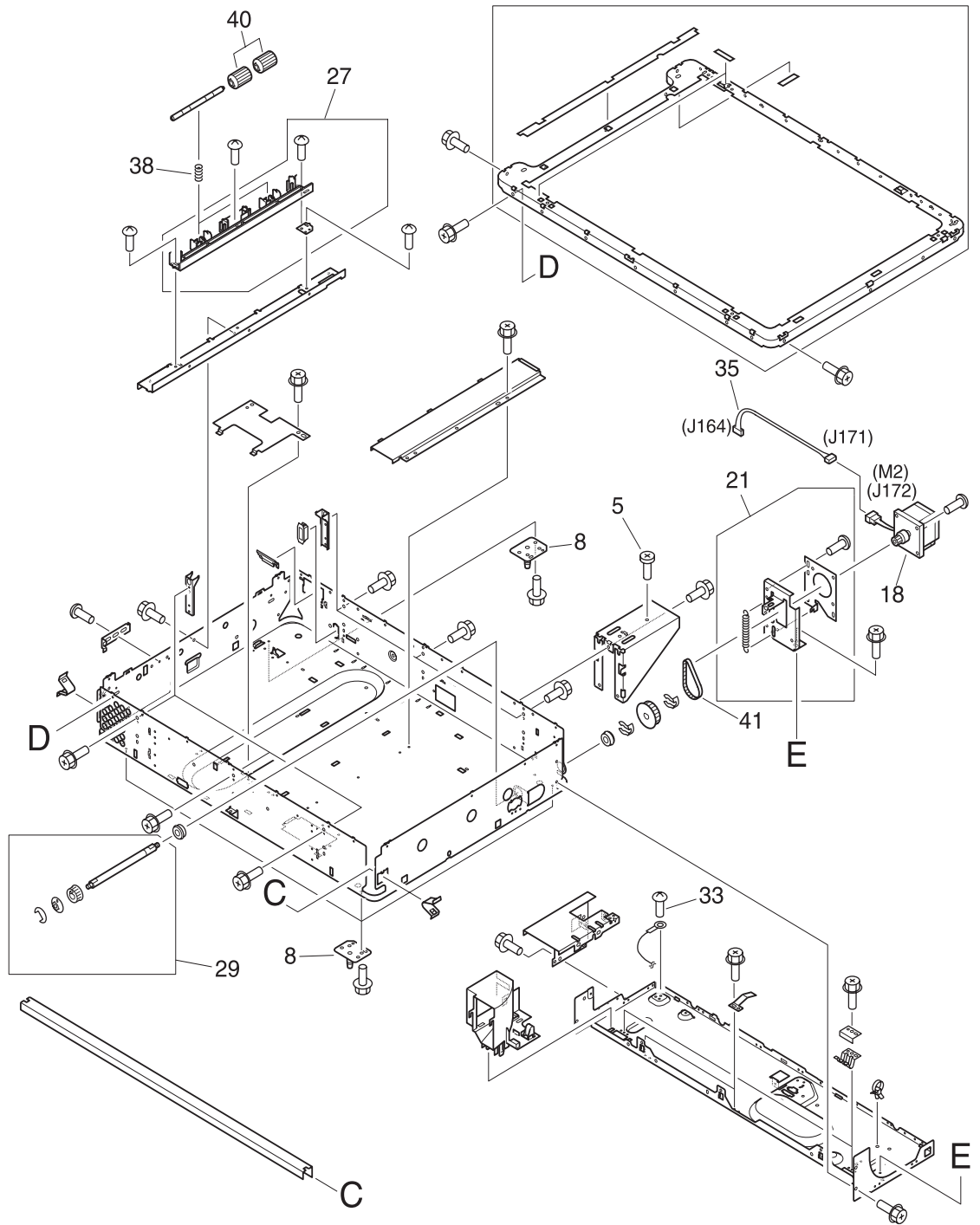
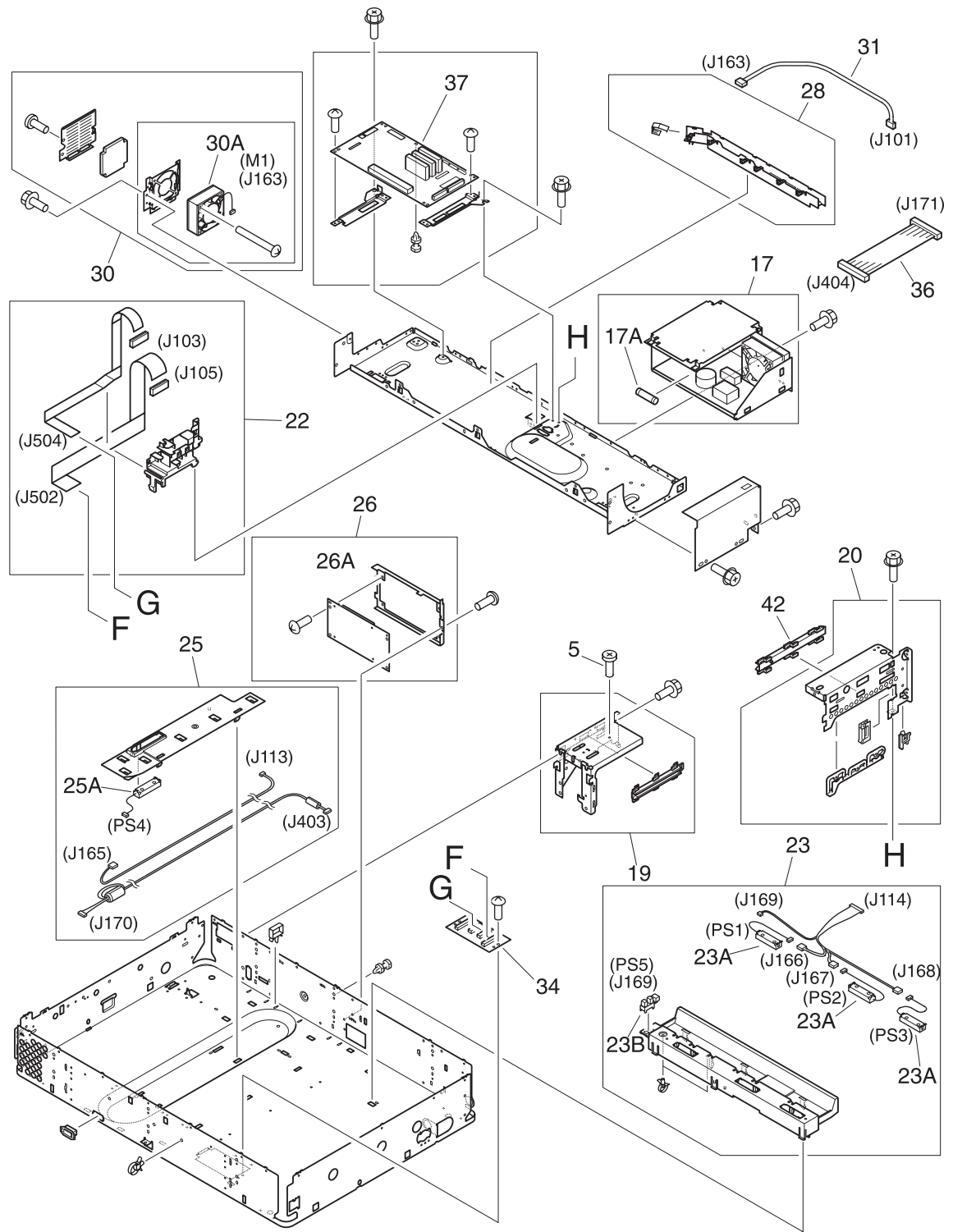


Figure 235. Flatbed scanner assembly (1 of 3)



**Figure 236.** Flatbed scanner assembly (2 of 3)



**Figure 237.** Flatbed scanner assembly (3 of 3)

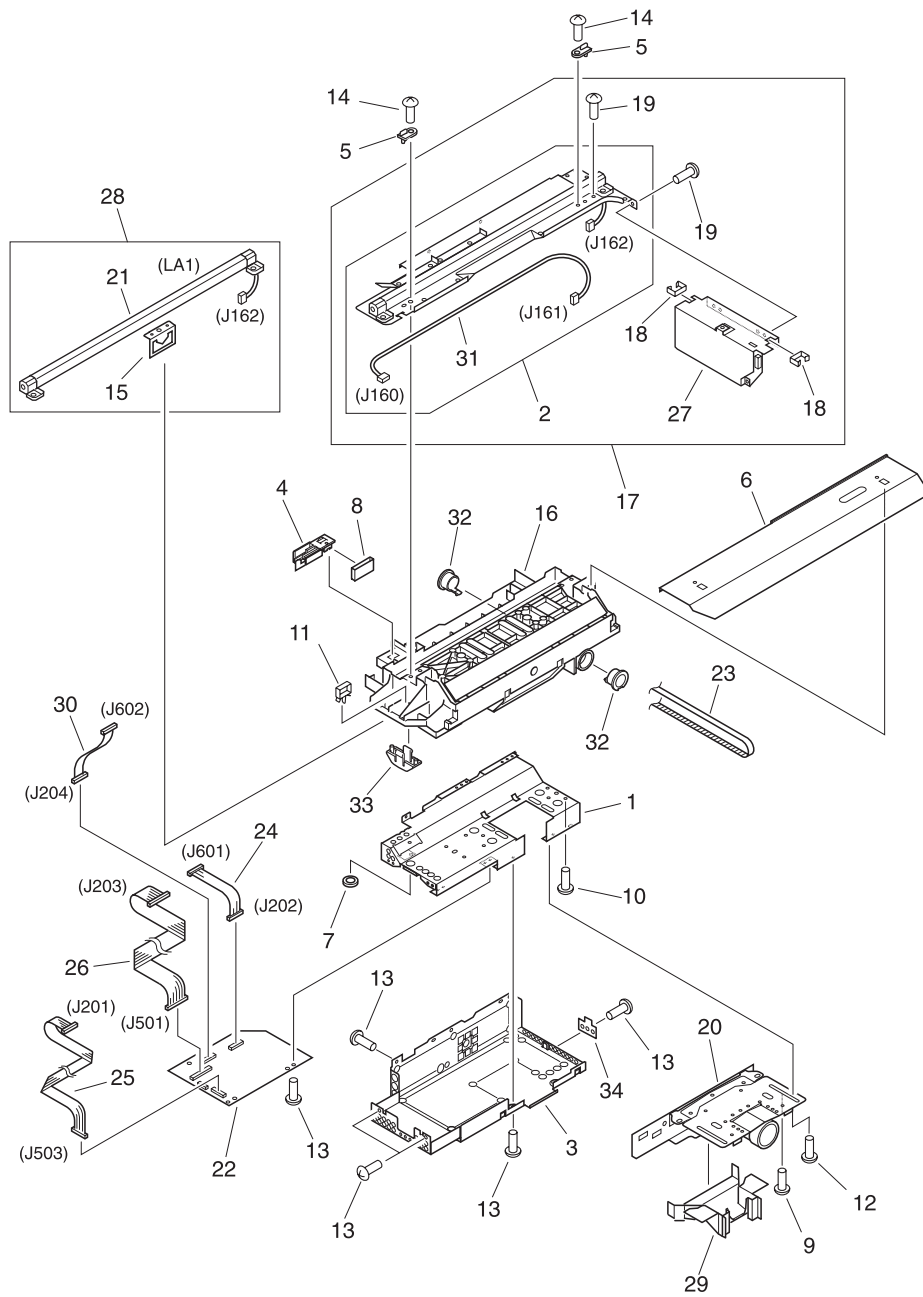
**Table 80. Flatbed scanner assembly**

Ref	Description	HP LJ 9000mfp HP LJ 9000Lmfp Part number	HP LJ 9040mfp HP LJ 9050mfp Part number	HP LJ 9500mfp Part number	Qty
1; Figure 235.	Cover, flatbed upper front <sup>1</sup> Cover, front lower <sup>2</sup>	RB2-7933-000CN	RB2-7933-000CN	RB2-7933-000CN	1
2; Figure 235.	Cover, flatbed lower front <sup>1</sup> Cover, front upper <sup>2</sup>	RB2-7934-000CN	RB2-7934-000CN	RB2-7934-000CN	1
3; Figure 235.	Cover, glass mount	RB2-7935-000CN	RB2-7935-000CN	RB2-7935-000CN	2
4; Figure 235.	Cover, flatbed right <sup>1</sup> Cover, right <sup>2</sup>	RB2-8063-000CN	RB2-8063-000CN	RB2-8063-000CN	1
5; Figure 236.	Screw	Not orderable	Not orderable	Not orderable	2
6; Figure 235.	Screw, RS M3X8	Not orderable	Not orderable	Not orderable	6
7; Figure 235.	Screw, M4X10	Not orderable	Not orderable	Not orderable	5
8; Figure 236.	Pivot, positioning	Not orderable	Not orderable	Not orderable	4
9; Figure 235.	Mount, glass alignment Mount, glass 3	RB2-7927-000CN	RB2-7927-000CN	RB2-7927-000CN	1
10; Figure 235.	Mount, glass 13	RB2-7928-000CN	RB2-7928-000CN	RB2-7928-000CN	3
11; Figure 235.	Reinforcement plate assembly	Not orderable	Not orderable	Not orderable	1
12; Figure 235.	Screw, M3X5	Not orderable	Not orderable	Not orderable	4
13; Figure 235.	Plate, base	Not orderable	Not orderable	Not orderable	1
14; Figure 235.	Flatbed glass <sup>1</sup> Copyboard glass unit <sup>2</sup>	RF5-3676-000CN	RF5-3676-000CN	RF5-3676-000CN	1
14A; Figure 235.	Plate, width index	Not orderable	Not orderable	Not orderable	1
15; Figure 235.	Screw, TP M3X6	Not orderable	Not orderable	Not orderable	2
16; Figure 235.	Screw, RS M3X6	Not orderable	Not orderable	Not orderable	6
17; Figure 237.	Power supply assembly	RG1-4153-000CN	RG1-4153-000CN	RG1-4153-000CN	1
17A; Figure 237.	Fuse, 250V, 5A	VD7-0645-000CN	VD7-0645-000CN	VD7-0645-000CN	1
18; Figure 236.	Motor, flatbed, 24vdc Motor, 24vdc	RH7-1485-000CN	RH7-1485-000CN	RH7-1485-000CN	1
19; Figure 237.	Left hinge assembly	Not orderable	Not orderable	Not orderable	1
20; Figure 236.	Cable, guide assembly	Not orderable	Not orderable	Not orderable	1
21; Figure 235.	Motor bracket assembly	Not orderable	Not orderable	Not orderable	1
22; Figure 237.	Scanner controller cable	RG5-6257-000CN	RG5-6257-000CN	RG5-6257-000CN	1
23; Figure 237.	Sensor crossmember assembly	RG5-6258-000CN	RG5-6258-000CN	RG5-6258-000CN	1
23A; Figure 237.	Sensor, document size	FH7-7423-000CN	Not applicable	FH7-7423-000CN	3
23B; Figure 237.	Photo interrupter, TLP1241	WG8-5362-000CN	Not applicable	WG8-5362-000CN	1
24; Figure 235.	Plate, shaft ground <sup>1</sup> Plate, slide shaft <sup>2</sup>	RB2-7920-000CN	RB2-7920-000CN	RB2-7920-000CN	1
25; Figure 237.	Flatbed sensor assembly	RG5-6259-000CN	RG5-7806-000CN	RG5-6259-000CN	1
25A; Figure 237.	Sensor, document size	FH7-7424-000CN	Not applicable	FH7-7424-000CN	1
26; Figure 237.	Intermediate PCB case	Not applicable	Not applicable	RH5-6260-000CN	1
26A; Figure 237.	Intermediate PCB	RH5-3074-000CN	RH5-7807-000CN	RH5-3074-000CN	1
27; Figure 236.	Lower delivery roller assembly <sup>1</sup> Delivery roller assembly <sup>2</sup>	RG5-6266-000CN	RG5-6266-000CN	RG5-6266-000CN	1

**Table 80. Flatbed scanner assembly (continued)**

Ref	Description	HP LJ 9000mfp HP LJ 9000Lmfp Part number	HP LJ 9040mfp HP LJ 9050mfp Part number	HP LJ 9500mfp Part number	Qty
28; Figure 237.	Ground cable	Not orderable	Not orderable	Not orderable	1
29; Figure 236.	Cartridge drive assembly	Not orderable	Not orderable	Not orderable	1
30; Figure 237.	Flatbed fan assembly <sup>1</sup> Fan assembly <sup>2</sup>	RG5-6318-000CN	RG5-6318-000CN	RG5-6318-000CN	1
30A; Figure 237.	Fan	Not orderable	Not orderable	Not orderable	1
31; Figure 237.	Cable, fan	Not orderable	Not orderable	Not orderable	1
32; Figure 235.	Reinforcement plate assembly	Not orderable	Not orderable	Not orderable	1
33; Figure 236.	Screw, M4X6	Not orderable	Not orderable	Not orderable	1
34; Figure 237.	Flatbed intermediate PCB	RH5-3073-000CN	RH5-3073-000CN	RH5-3073-000CN	1
35; Figure 236.	Scanner motor cable	Not orderable	Not orderable	Not orderable	1
36; Figure 237.	DC controller cable	Not orderable	Not orderable	Not orderable	1
37; Figure 237.	Scanner controller PCB	RH5-3075-000CN	RH5-3075-090CN	RH5-3122-000CN	1
38; Figure 236.	Spring, compression	RS6-2492-000CN	RS6-2492-000CN	RS6-2492-000CN	2
39; Figure 235.	Label, adjustment	Not orderable	Not orderable	Not orderable	1
40; Figure 236.	Lower delivery roller	RB2-7884-000CN	RB2-7884-000CN	RB2-7884-000CN	4
41; Figure 236.	Belt, timing	Not orderable	Not orderable	Not orderable	1
42; Figure 237.	Guide, slide	Not orderable	Not orderable	Not orderable	1
<sup>1</sup> HP LaserJet 9000mfp/9000Lmfp component description <sup>2</sup> HP LaserJet 9040mfp/9050mfp/9500mfp component description					

# Flatbed optical assembly



**Figure 238.** Flatbed optical assembly

**Table 81. Flatbed optical assembly**

Ref	Description	HP LJ 9000mfp HP LJ 9000Lmfp Part number	HP LJ 9040mfp HP LJ 9050mfp Part number	HP LJ 9500mfp Part number	Qty
All; Figure 238.	Flatbed optical assembly	RG5-6263-000CN	RG5-6263-000CN	RG5-6263-000CN	1
1; Figure 238.	Cover, shield	Not orderable	Not orderable	Not orderable	1
2; Figure 238.	Lamp assembly	Not orderable	Not orderable	Not orderable	1
3; Figure 238.	Plate, shield	Not orderable	Not orderable	Not orderable	1
4; Figure 238.	Holder FFC	Not orderable	Not orderable	Not orderable	1
5; Figure 238.	Spindle	Not orderable	Not orderable	Not orderable	2
6; Figure 238.	Guide, cartridge	Not orderable	Not orderable	Not orderable	1
7; Figure 238.	Edge, cable	Not orderable	Not orderable	Not orderable	1
8; Figure 238.	Ferrite core	Not orderable	Not orderable	Not orderable	1
9; Figure 238.	Screw, w/washer M4X6	Not orderable	Not orderable	Not orderable	2
10; Figure 238.	Screw, M3X12	Not orderable	Not orderable	Not orderable	4
11; Figure 238.	Clamp, cable	Not orderable	Not orderable	Not orderable	1
12; Figure 238.	Screw, w/washer M3X12	Not orderable	Not orderable	Not orderable	4
13; Figure 238.	Screw, TP M3X6	Not orderable	Not orderable	Not orderable	8
14; Figure 238.	Screw, M4X10	Not orderable	Not orderable	Not orderable	2
15; Figure 238.	Plate, shading	Not orderable	Not orderable	Not orderable	1
16; Figure 238.	Flatbed sub frame assembly	Not orderable	Not orderable	Not orderable	1
17; Figure 238.	Flatbed lamp assembly	Not orderable	Not orderable	Not orderable	1
18; Figure 238.	Clip, cable	Not orderable	Not orderable	Not orderable	2
19; Figure 238.	Screw, TP M3X6	Not orderable	Not orderable	Not orderable	3
20; Figure 238.	CCD lens assembly	Not orderable	Not orderable	Not orderable	1
21; Figure 238.	Lamp	Not orderable	Not orderable	Not orderable	1
22; Figure 238.	Flatbed analog processor	Not orderable	Not orderable	Not orderable	1
23; Figure 238.	Belt, timing	Not orderable	Not orderable	Not orderable	1
24; Figure 238.	Cable, CCD	Not orderable	Not orderable	Not orderable	1
25; Figure 238.	Cable, flatbed	Not orderable	Not orderable	Not orderable	1
26; Figure 238.	Cable, power	Not orderable	Not orderable	Not orderable	1
27; Figure 238.	Inverter PCB assembly	RH7-3065-000CN	Not orderable	Not orderable	1
28; Figure 238.	Flatbed lamp assembly	RG5-6323-000CN	Not orderable	Not orderable	1
29; Figure 238.	Cover, lens	RB2-7902-000CN	Not orderable	Not orderable	1
30; Figure 238.	Cable, scanner	Not orderable	Not orderable	Not orderable	1
31; Figure 238.	Cable, lamp	Not orderable	Not orderable	Not orderable	1
32; Figure 238.	Bushing	Not orderable	Not orderable	Not orderable	2
33; Figure 238.	Block, slide	Not orderable	Not orderable	Not orderable	1
34; Figure 238.	Sheet, cover	Not orderable	Not orderable	Not orderable	1
<sup>1</sup> HP LaserJet 9000mfp/9000Lmfp component description <sup>2</sup> HP LaserJet 9040mfp/9050mfp/9500mfp component description					



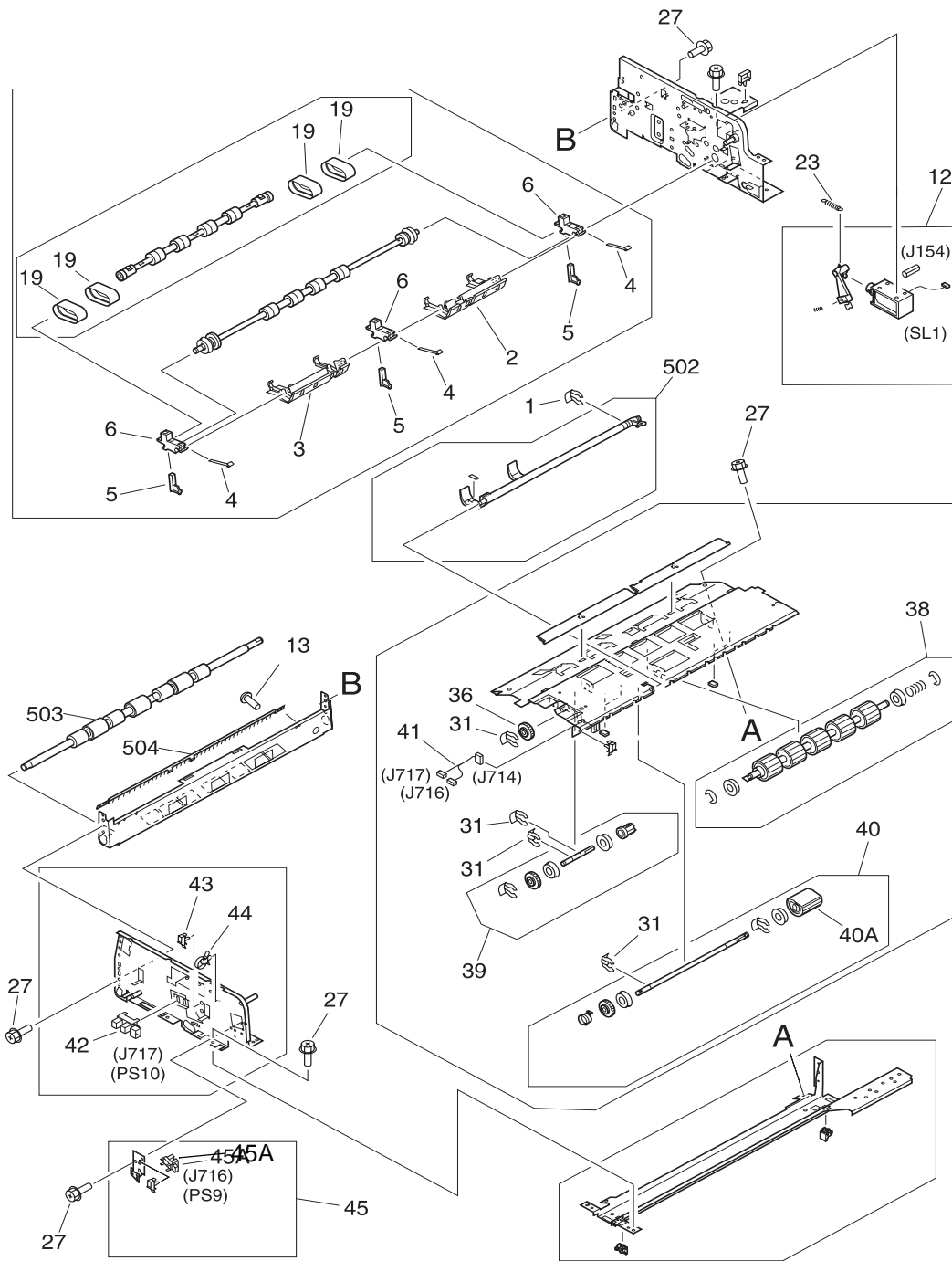
**Table 82. ADF scanner assembly**

Ref	Description	HP LJ 9000mfp HP LJ 9000Lmfp Part number	HP LJ 9040mfp HP LJ 9050mfp Part number	HP LJ 9500mfp Part number	Qty
1; Figure 239.	Plate, support	Not orderable	Not orderable	Not orderable	1
2; Figure 239.	Guide, harness 1	Not orderable	Not orderable	Not orderable	1
3; Figure 239.	Guide, harness 2	Not orderable	Not orderable	Not orderable	1
4; Figure 239.	Cover, ADF feeder <sup>1</sup> Cover, jam <sup>2</sup>	RB2-8040-000CN	RB2-8040-000CN	RB2-8040-000CN	1
5; Figure 239.	Guide, I/F 1	RB2-8046-000CN	RB2-8046-000CN	RB2-8046-000CN	1
6; Figure 239.	Guide, I/F 4	RB2-8047-000CN	RB2-8047-000CN	RB2-8047-000CN	1
7; Figure 239.	Cover, ADF front <sup>1</sup> Cover, front <sup>2</sup>	RB2-8048-000CN	RB2-8048-000CN	RB2-8048-000CN	1
8; Figure 239.	Screw, M4X8	Not orderable	Not orderable	Not orderable	2
9; Figure 239.	Screw, stepped M4X12	Not orderable	Not orderable	Not orderable	2
10; Figure 239.	Ferrite core	RB2-8678-000CN	RB2-8678-000CN	RB2-8678-000CN	1
11; Figure 239.	Guide, I/F 5	RB2-8681-000CN	RB2-8681-000CN	RB2-8681-000CN	1
12; Figure 239.	Guide, I/F 6	RB2-8682-000CN	RB2-8682-000CN	RB2-8682-000CN	1
13; Figure 239.	Guide, harness	Not orderable	Not orderable	Not orderable	1
14; Figure 239.	Screw, w/washer M4X6	Not orderable	Not orderable	Not orderable	1
15; Figure 239.	Holder, ADF stop <sup>1</sup> Holder, stop <sup>2</sup>	RB2-8693-000CN	RB2-8693-000CN	RB2-8693-000CN	1
16; Figure 239.	Cushion	Not orderable	Not orderable	Not orderable	1
17; Figure 239.	ADF optical unit filter <sup>1</sup> Cover, lamp right <sup>2</sup>	RF5-3850-000CN	RF5-3850-000CN	RF5-3850-000CN	1
18; Figure 239.	Processing PCB cable	RH2-5456-000CN	RH2-5456-000CN	RH2-5456-000CN	1
19; Figure 239.	Clamp, cable	Not orderable	Not orderable	Not orderable	1
20; Figure 239.	Clamp, cable	Not orderable	Not orderable	Not orderable	1
21; Figure 239.	Screw, M4X10	Not orderable	Not orderable	Not orderable	7
22; Figure 239.	Screw, RS M3X6	Not orderable	Not orderable	Not orderable	1
23; Figure 239.	Screw, RS M3X8	Not orderable	Not orderable	Not orderable	5
24; Figure 239.	ADF base cover assembly <sup>1</sup> Base, cover assembly <sup>2</sup>	RG5-6272-050CN	RG5-6272-050CN	RG5-6272-050CN	1
25; Figure 239.	Back cover assembly	Not orderable	Not orderable	Not orderable	1
26; Figure 239.	ADF width sensor assembly	RG5-6274-000CN	RG5-6274-000CN	RG5-6274-000CN	1
27; Figure 239.	ADF intermediate PCB	RH5-3078-000CN	RH5-3078-000CN	RH5-3078-000CN	1
28; Figure 239.	ADF sensor cable	Not orderable	Not orderable	Not orderable	1
29; Figure 239.	Cable, guide assembly	RG5-6311-000CN	RG5-6311-000CN	RG5-6311-000CN	1
30; Figure 239.	ADF fan assembly	RG5-6312-000CN	RG5-6312-000CN	RG5-6312-000CN	1
30A; Figure 239.	ADF solenoid cable	Not orderable	Not orderable	Not orderable	1
30B; Figure 239.	Fan, ADF <sup>1</sup> Fan <sup>2</sup>	RH7-1486-000CN	RH7-1486-000CN	RH7-1486-000CN	1
31; Figure 239.	I/F cable guide assembly	RG5-6313-000CN	RG5-6313-000CN	RG5-6313-000CN	1
32; Figure 239.	Lever, sensor	RB2-7943-000CN	RB2-7943-000CN	RB2-7943-000CN	1

**Table 82. ADF scanner assembly (continued)**

Ref	Description	HP LJ 9000mfp HP LJ 9000Lmfp Part number	HP LJ 9040mfp HP LJ 9050mfp Part number	HP LJ 9500mfp Part number	Qty
33; Figure 239.	Photo-interrupter, TLP1241	WG8-5362-000CN	WG8-5362-000CN	WG8-5362-000CN	2
34; Figure 239.	Guide, back ADF tray <sup>1</sup> Guide, rear tray <sup>2</sup>	RF5-3682-000CN	RF5-3682-000CN	RF5-3682-000CN	1
35; Figure 239.	Guide, front tray	RF5-3698-000CN	RF5-3698-000CN	RF5-3698-000CN	1
35; Figure 239.	Tray, rack	RB2-7939-000CN	RB2-7939-000CN	RB2-7939-000CN	1
<sup>1</sup> HP LaserJet 9000mfp/9000Lmfp component description <sup>2</sup> HP LaserJet 9040mfp/9050mfp/9500mfp component description					

# Paper pickup assembly



**Figure 240.** Paper pickup assembly (1 of 2)



**Table 83. Paper pickup assembly**

Ref	Description	HP LJ 9000mfp HP LJ 9000Lmfp Part number	HP LJ 9040mfp HP LJ 9050mfp Part number	HP LJ 9500mfp Part number	Qty
All; Figure 240. All; Figure 241.	Paper pickup assembly	RG5-6275-000CN	RG5-6275-000CN	RG5-6275-000CN	1
1; Figure 240. 1; Figure 241.	Clip	Not orderable	Not orderable	Not orderable	6
2; Figure 240.	Arm, flapper rear <sup>1</sup> Arm, flapper rear <sup>2</sup>	RF5-3689-000CN	RF5-3689-000CN	RF5-3689-000CN	1
3; Figure 240.	Arm, flapper front <sup>1</sup> Arm, flapper <sup>2</sup>	RF5-3688-000CN	RF5-3688-000CN	RF5-3688-000CN	1
4; Figure 240.	Spring, leaf	RB2-7991-000CN	RB2-7991-000CN	RB2-7991-000CN	3
5; Figure 240.	Holder, spring	RB2-7990-000CN	RB2-7990-000CN	RB2-7990-000CN	3
6; Figure 240.	Holder, separation	RB2-7989-000CN	RB2-7989-000CN	RB2-7989-000CN	3
7; Figure 241.	Spring, tension	Not orderable	Not orderable	Not orderable	1
8; Figure 241.	Plate, bracket	Not orderable	Not orderable	Not orderable	1
9; Figure 241.	Lever, empty	RB2-8002-000CN	RB2-8002-000CN	RB2-8002-000CN	1
10; Figure 241.	Belt, timing	Not orderable	Not orderable	Not orderable	1
11; Figure 241.	Belt, timing	Not orderable	Not orderable	Not orderable	1
12; Figure 240.	Weight solenoid assembly	RG5-6289-000CN	RG5-6289-000CN	RG5-6289-000CN	1
13; Figure 240.	Screw, M3X5	Not orderable	Not orderable	Not orderable	3
14; Figure 241.	Bushing	Not orderable	Not orderable	Not orderable	1
15; Figure 241.	Bushing	Not orderable	Not orderable	Not orderable	2
16; Figure 241.	Weight assembly	RG5-6298-000CN	RG5-6298-000CN	RG5-6298-000CN	1
16A; Figure 241.	Arm, weight	Not orderable	Not orderable	Not orderable	1
16B; Figure 241.	Weight holder assembly	Not orderable	Not orderable	Not orderable	1
16C; Figure 241.	Holder, weight plate	RB2-7999-000CN	RB2-7999-000CN	RB2-7999-000CN	1
17; Figure 241.	Bushing	Not orderable	Not orderable	Not orderable	1
18; Figure 241.	Arm, tension	Not orderable	Not orderable	Not orderable	1
19; Figure 240.	Belt, separation <sup>1</sup> Belt, timing <sup>2</sup>	RB2-7988-000CN	RB2-7988-000CN	RB2-7988-000CN	4
20; Figure 241.	Pulley 17T	Not orderable	Not orderable	Not orderable	1
21; Figure 241.	Spring, tension	Not orderable	Not orderable	Not orderable	1
22; Figure 241.	Spring, tension	RS6-2496-000CN	RS6-2496-000CN	RS6-2496-000CN	1
23; Figure 241.	Spring, tension	RS6-2498-000CN	RS6-2498-000CN	RS6-2498-000CN	1
24; Figure 241.	Gear, 16T	Not orderable	Not orderable	Not orderable	1
25; Figure 241.	Empty sensor bracket	Not orderable	Not orderable	Not orderable	1
25A; Figure 241.	Micro-switch	WC4-5175-000CN	WC4-5175-000CN	WC4-5175-000CN	1
25B; Figure 241.	Photo-interrupter, TLP1241	Not orderable	Not orderable	Not orderable	1
26; Figure 241.	Screw, M3X8	Not orderable	Not orderable	Not orderable	6
27; Figure 240. 27; Figure 241.	Screw, RS M3X6	Not orderable	Not orderable	Not orderable	23
28; Figure 241.	Gear shaft assembly	Not orderable	Not orderable	Not orderable	1

**Table 83. Paper pickup assembly (continued)**

Ref	Description	HP LJ 9000mfp HP LJ 9000Lmfp Part number	HP LJ 9040mfp HP LJ 9050mfp Part number	HP LJ 9500mfp Part number	Qty
29; Figure 241.	Drive tension bracket	Not orderable	Not orderable	Not orderable	1
29A; Figure 241.	Bracket, tension	Not orderable	Not orderable	Not orderable	1
29B; Figure 241.	Screw, M4X8	Not orderable	Not orderable	Not orderable	2
29C; Figure 241.	Clamp	Not orderable	Not orderable	Not orderable	2
29D; Figure 241.	Motor, pickup 24vdc <sup>1</sup> Motor, 24vdc <sup>2</sup>	RH7-1488-000CN	RH7-1488-000CN	RH7-1488-000CN	1
30; Figure 241.	Screw, M3X8	Not orderable	Not orderable	Not orderable	3
31; Figure 240.	Clip	Not orderable	Not orderable	Not orderable	4
32; Figure 241.	Spring, tension	Not orderable	Not orderable	Not orderable	1
33; Figure 241.	Spring, tension	RS6-2496-000CN	RS6-2496-000CN	RS6-2496-000CN	1
34; Figure 241.	Solenoid, shutter <sup>1</sup> Solenoid <sup>2</sup>	RH7-5312-000CN	RH7-5312-000CN	RH7-5312-000CN	1
35; Figure 241.	Mount, motor	Not orderable	Not orderable	Not orderable	1
36; Figure 240.	Gear, 28T	Not orderable	Not orderable	Not orderable	1
37; Figure 241.	Bushing	Not orderable	Not orderable	Not orderable	1
38; Figure 240.	Feed roller assembly <sup>1</sup> Separation roller assembly <sup>2</sup>	RG5-6281-000CN	RG5-6281-000CN	RG5-6281-000CN	1
39; Figure 240.	Separation shaft assembly	Not orderable	Not orderable	Not orderable	1
40; Figure 240.	Pickup (D-roller) assembly <sup>1</sup> Pickup roller assembly <sup>2</sup>	RG5-6283-000CN	RG5-6283-000CN	RG5-6283-000CN	1
40A; Figure 240.	Roller, pickup	RB2-7961-000CN	RB2-7961-000CN	RB2-7961-000CN	1
41; Figure 240.	ADF sensor cable	Not orderable	Not orderable	Not orderable	1
42; Figure 240.	Photo-interrupter, TLP1241	Not orderable	Not orderable	Not orderable	1
43; Figure 240.	Clamp. cable	Not orderable	Not orderable	Not orderable	1
44; Figure 240.	Clamp. cable	Not orderable	Not orderable	Not orderable	1
45; Figure 240.	Pickup sensor assembly	RG5-6285-000CN	RG5-6285-000CN	RG5-6285-000CN	1
45A; Figure 240.	Photo-interrupter, TLP1241	WG8-5362-000CN	WG8-5362-000CN	WG8-5362-000CN	
46; Figure 241.	Drive motor assembly	Not orderable	Not orderable	Not orderable	1
47; Figure 241.	Feed motor assembly	Not orderable	Not orderable	Not orderable	1
47A; Figure 241.	Plate, motor mount	Not orderable	Not orderable	Not orderable	1
47B; Figure 241.	Clamp	Not orderable	Not orderable	Not orderable	3
47C; Figure 241.	Motor, delivery, 24vdc <sup>1</sup> Motor, 24vdc <sup>2</sup>	RH7-1487-000CN	RH7-1487-000CN	RH7-1487-000CN	1
47D; Figure 241.	Screw, RS M3X6	Not orderable	Not orderable	Not orderable	2
48; Figure 241.	Flag, empty	RG5-6290-000CN	RG5-6290-000CN	RG5-6290-000CN	1
49; Figure 241.	Belt, timing	Not orderable	Not orderable	Not orderable	1
50; Figure 241.	Clip	Not orderable	Not orderable	Not orderable	1
51; Figure 241.	Lever, shutter	Not orderable	Not orderable	Not orderable	1
501; Figure 241.	Screw, TP M3X4	Not orderable	Not orderable	Not orderable	1
502; Figure 240.	Shutter assembly	RG5-6286-000CN	RG5-6286-000CN	RG5-6286-000CN	1

**Table 83. Paper pickup assembly (continued)**

Ref	Description	HP LJ 9000mfp HP LJ 9000Lmfp Part number	HP LJ 9040mfp HP LJ 9050mfp Part number	HP LJ 9500mfp Part number	Qty
503; Figure 240.	Roller, upper delivery assembly <sup>1</sup> Roller delivery <sup>2</sup>	RB2-7950-000CN	RB2-7950-000CN	RB2-7950-000CN	1
504; Figure 240.	Static charge eliminator	RB2-7970-000CN	RB2-7970-000CN	RB2-7970-000CN	1
505; Figure 241.	Flag, ADF open <sup>1</sup> Lever, open <sup>2</sup>	RB2-7964-000CN	RB2-7964-000CN	RB2-7964-000CN	1
506; Figure 241.	Lower registration roller assembly <sup>1</sup> Registration roller assembly <sup>2</sup>	RG5-6277-000CN	RG5-6277-000CN	RG5-6277-000CN	1

<sup>1</sup> HP LaserJet 9000mfp/9000Lmfp component description

<sup>2</sup> HP LaserJet 9040mfp/9050mfp/9500mfp component description

# ADF main assembly

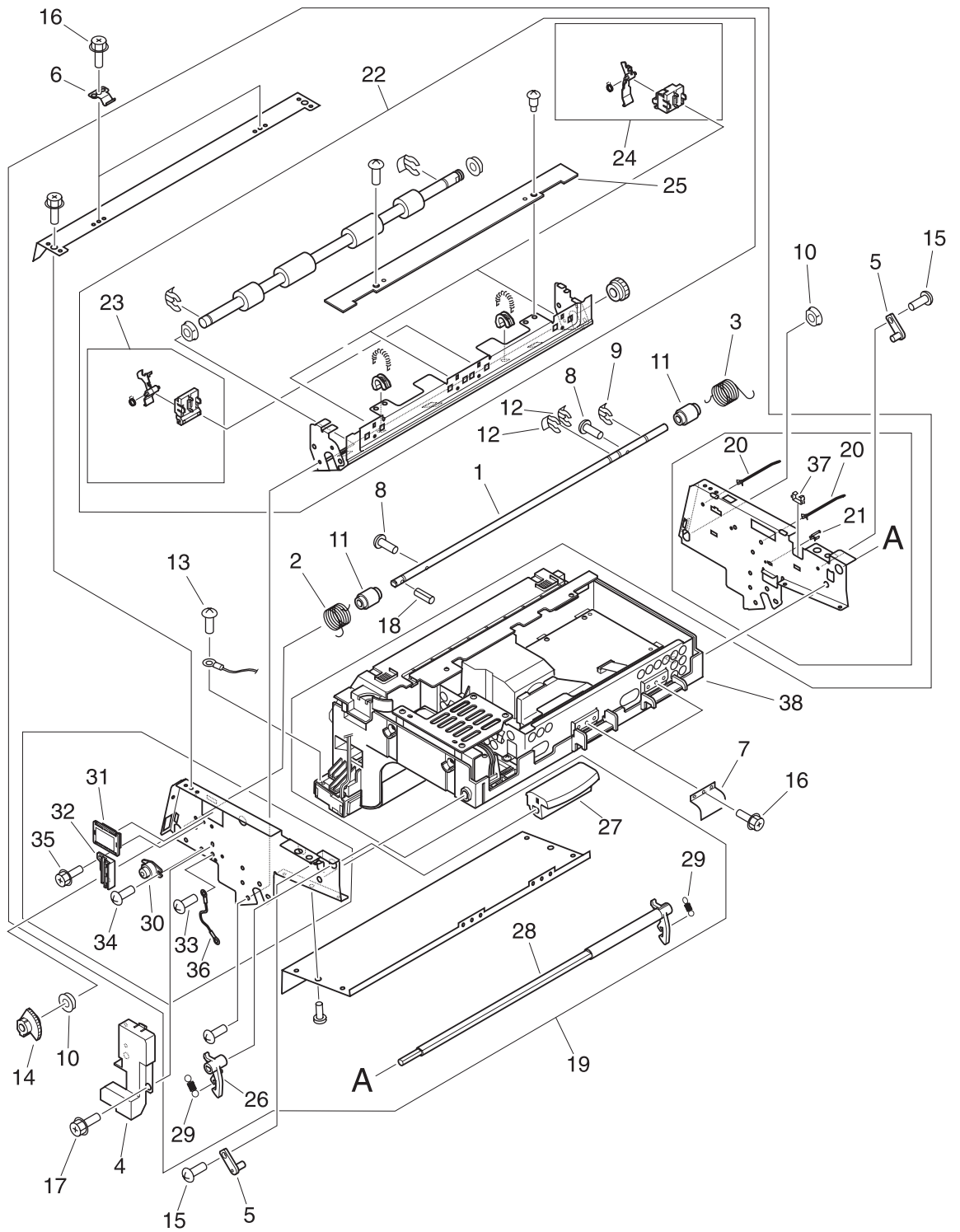


Figure 242. ADF main assembly

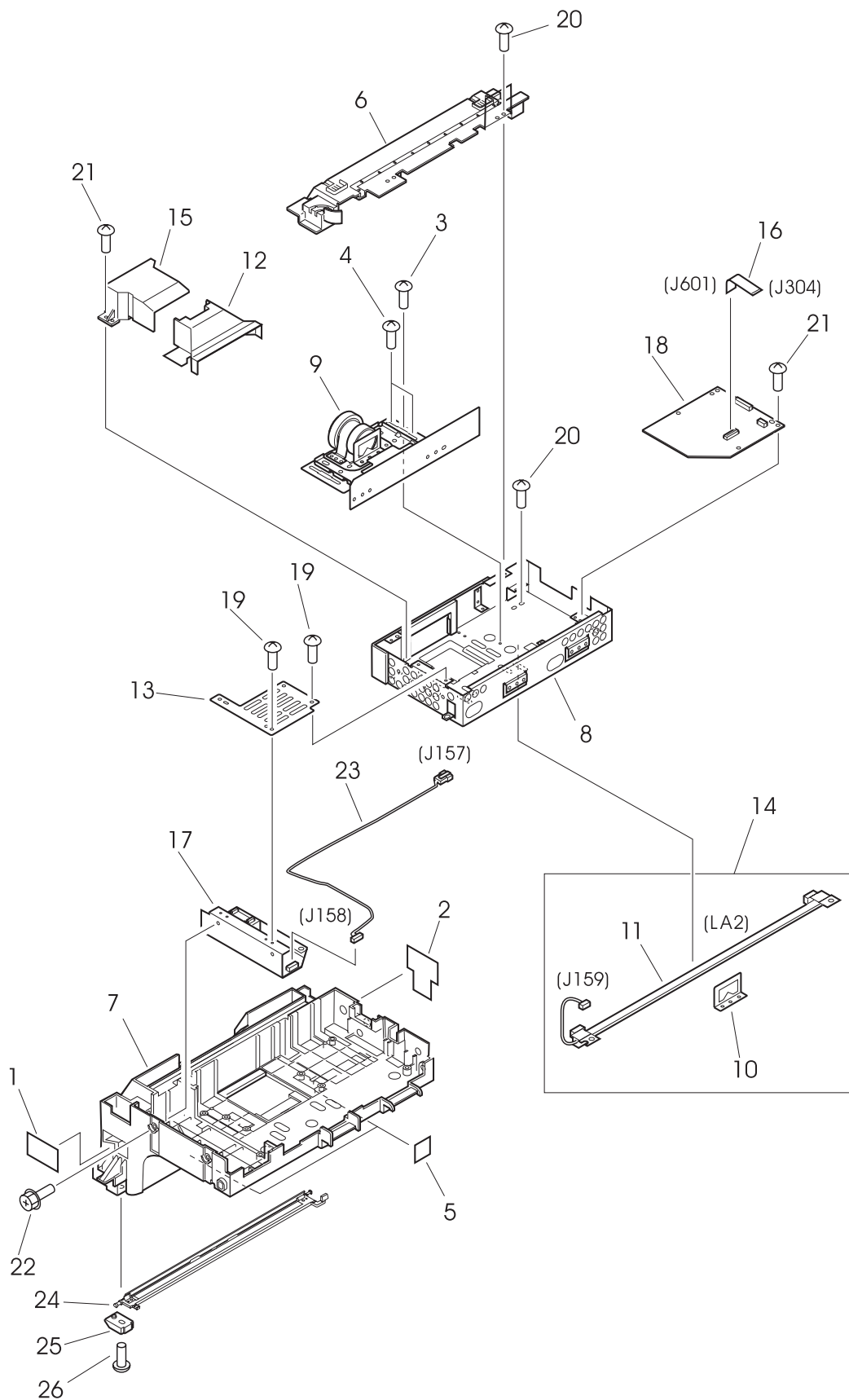
**Table 84. ADF main assembly**

Ref	Description	HP LJ 9000mfp HP LJ 9000Lmfp Part number	HP LJ 9040mfp HP LJ 9050mfp Part number	HP LJ 9500mfp Part number	Qty
All; Figure 242.	ADF main assembly	RG5-7379-000CN	RG5-7379-000CN	RG5-7379-000CN	1
1; Figure 242.	Shaft, support	Not orderable	Not orderable	Not orderable	1
2; Figure 242.	Spring, torsion	Not orderable	Not orderable	Not orderable	1
3; Figure 242.	Spring, torsion	Not orderable	Not orderable	Not orderable	1
4; Figure 242.	Cover, cable	Not orderable	RB2-8031-000CN	RB2-8031-000CN	3
5; Figure 242.	Pin	Not orderable	Not orderable	Not orderable	2
6; Figure 242.	Spring, leaf	Not orderable	Not orderable	Not orderable	2
7; Figure 242.	Spring, leaf	Not orderable	Not orderable	Not orderable	2
8; Figure 242.	Screw, M4X6	Not orderable	Not orderable	Not orderable	2
9; Figure 242.	Ring, stop	Not orderable	Not orderable	Not orderable	1
10; Figure 242.	Bushing	Not orderable	Not orderable	Not orderable	2
11; Figure 242.	Collar	Not orderable	Not orderable	Not orderable	2
12; Figure 242.	Clip	Not orderable	Not orderable	Not orderable	2
13; Figure 242.	Screw, w/washer M4X6	Not orderable	Not orderable	Not orderable	1
14; Figure 242.	Gear, 50T	Not orderable	Not orderable	Not orderable	1
15; Figure 242.	Screw, M3X8	Not orderable	Not orderable	Not orderable	2
16; Figure 242.	Screw, RS M3X6	Not orderable	Not orderable	Not orderable	6
17; Figure 242.	Screw, RS M3X8	Not orderable	Not orderable	Not orderable	2
18; Figure 242.	Pin, spring	Not orderable	Not orderable	Not orderable	1
19; Figure 242.	Cartridge frame assembly	Not orderable	Not orderable	Not orderable	1
20; Figure 242.	Clamp, cable	Not orderable	Not orderable	Not orderable	2
21; Figure 242.	Clamp, cable	Not orderable	Not orderable	Not orderable	1
22; Figure 242.	Upper registration guide assy <sup>1</sup> Registration guide assembly <sup>2</sup>	RG5-6304-000CN	RG5-6304-000CN	RG5-6304-000CN	4
23; Figure 242.	Registration sensor holder assy	RG5-6305-000CN	RG5-6305-000CN	RG5-6305-000CN	1
24; Figure 242.	Timing sensor holder assembly	RG5-6306-000CN	RG5-6306-000CN	RG5-6306-000CN	3
24; Figure 242.	ADF sensor PCB assembly	RH5-3079-000CN	RH5-3079-000CN	RH5-3079-000CN	1
26; Figure 242.	Lever, handle <sup>1</sup> Lever, knob <sup>2</sup>	RB2-8017-000CN	RB2-8017-000CN	RB2-8017-000CN	1
27; Figure 242.	Handle <sup>1</sup> Knob <sup>2</sup>	RB2-8015-000CN	RB2-8015-000CN	RB2-8015-000CN	1
28; Figure 242.	Shaft, handle <sup>1</sup> Shaft, knob <sup>2</sup>	RB2-8016-000CN	RB2-8016-000CN	RB2-8016-000CN	1
29; Figure 242.	Spring, tension	RS6-2503-000CN	RS6-2503-000CN	RS6-2503-000CN	2
30; Figure 242.	Gear damper unit	Not orderable	Not orderable	Not orderable	1
31; Figure 242.	Guide, edge	Not orderable	Not orderable	Not orderable	1
32; Figure 242.	Guide, cable	Not orderable	Not orderable	Not orderable	1
33; Figure 242.	Screw, w/washer M4X6	Not orderable	Not orderable	Not orderable	1

**Table 84. ADF main assembly (continued)**

Ref	Description	HP LJ 9000mfp HP LJ 9000Lmfp Part number	HP LJ 9040mfp HP LJ 9050mfp Part number	HP LJ 9500mfp Part number	Qty
34; Figure 242.	Screw, M3X8	Not orderable	Not orderable	Not orderable	2
35; Figure 242.	Screw, RS M3X8	Not orderable	Not orderable	Not orderable	1
36; Figure 242.	Grounding cable	Not orderable	Not orderable	Not orderable	1
37; Figure 242.	Guide, cable	Not orderable	Not orderable	Not orderable	1
38; Figure 242.	ADF optical assembly	RG5-6307-000CN	RG5-6307-000CN	RG5-7380-000CN	1
<sup>1</sup> HP LaserJet 9000mfp/9000Lmfp component description <sup>2</sup> HP LaserJet 9040mfp/9050mfp/9500mfp component description					

# ADF optical assembly

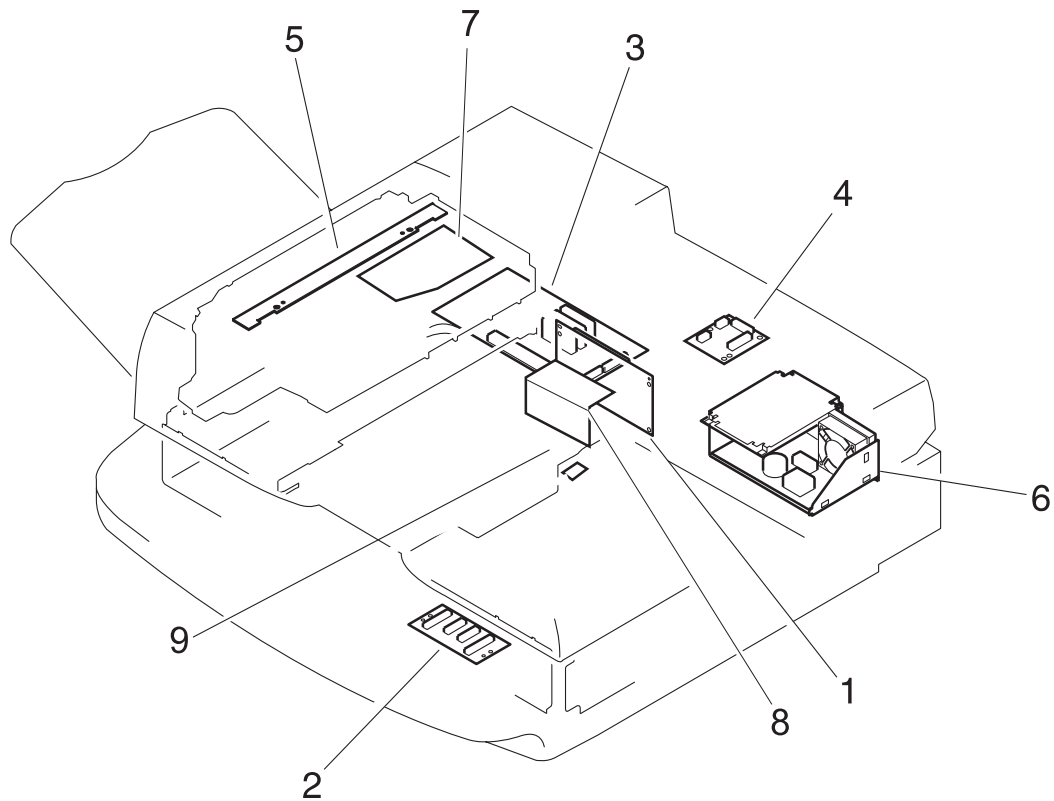


**Figure 243.** ADF optical assembly

**Table 85. ADF optical assembly**

Ref	Description	HP LJ 9000mfp HP LJ 9000Lmfp Part number	HP LJ 9040mfp HP LJ 9050mfp Part number	HP LJ 9500mfp Part number	Qty
All; Figure 243.	ADF optical assembly	RG5-6307-000CN	RG5-6307-000CN	RG5-7380-000CN	1
1; Figure 243.	Sheet, front	Not orderable	Not orderable	Not orderable	1
2; Figure 243.	Sheet, rear	Not orderable	Not orderable	Not orderable	1
3; Figure 243.	Screw, w/washer M4X6	Not orderable	Not orderable	Not orderable	2
4; Figure 243.	Screw, w/washer M3x12	Not orderable	Not orderable	Not orderable	4
5; Figure 243.	Damper sheet	Not orderable	Not orderable	Not orderable	2
6; Figure 243.	Cover, unit	Not orderable	Not orderable	Not orderable	1
7; Figure 243.	ADF scanner assembly chassis	Not orderable	Not orderable	Not orderable	1
8; Figure 243.	ADF shield box assembly	Not orderable	Not orderable	Not orderable	1
9; Figure 243.	ADF Lens assembly	Not orderable	Not orderable	Not orderable	1
10; Figure 243.	Plate, shading	Not orderable	Not orderable	Not orderable	1
11; Figure 243.	Lamp	Not orderable	Not orderable	Not orderable	1
12; Figure 243.	Cover, lens	RB2-7902-000CN	Not orderable	Not orderable	1
13; Figure 243.	Plate, heat sink	Not orderable	Not orderable	Not orderable	1
14; Figure 243.	ADF lamp assembly	RG5-6322-000CN	Not orderable	Not orderable	1
15; Figure 243.	Cover, lens	RB2-6307-000CN	Not orderable	Not orderable	1
16; Figure 243.	Cable, CCD	Not orderable	Not orderable	RH2-5453-000CN	1
17; Figure 243.	Inverter PCB assembly	RH7-3065-000CN	Not orderable	Not orderable	1
18; Figure 243.	ADF analog processor PCB	RH5-3082-000CN	Not orderable	RH5-3082-000CN	1
19; Figure 243.	Screw, TP M3X6	Not orderable	Not orderable	Not orderable	4
20; Figure 243.	Screw, M4X10	Not orderable	Not orderable	Not orderable	4
21; Figure 243.	Screw, M3X8	Not orderable	Not orderable	Not orderable	8
22; Figure 243.	Screw, RS M3x6	Not orderable	Not orderable	Not orderable	2
23; Figure 243.	Cable, ADF inverter	Not orderable	Not orderable	Not orderable	1
24; Figure 243.	Flip-down glass assembly	Not orderable	Not orderable	RG5-6320-000CN	1
25; Figure 243.	Plate, glass	Not orderable	Not orderable	Not orderable	2
26; Figure 243.	Screw, TP M3X6	Not orderable	Not orderable	Not orderable	2

## PCB assemblies



**Figure 244.** PCB assemblies

**Table 86.** PCB assemblies

Ref	Description	HP LJ 9000mfp HP LJ 9000Lmfp Part number	HP LJ 9040mfp HP LJ 9050mfp Part number	HP LJ 9500mfp Part number	Qty
1; Figure 244.	Intermediate PCB assembly	RH5-3074-000CN	RH5-7807-000CN	RH5-3074-000CN	1
2; Figure 244.	Flatbed intermediate PCB assy	RH5-3073-000CN	RH5-3073-000CN	RH5-3073-000CN	1
3; Figure 244.	Scanner controller PCB assy	RH5-3075-000CN	RH5-3075-090CN	RH5-3122-000CN	1
4; Figure 244.	ADF intermediate PCB assembly	RH5-3078-000CN	RH5-3078-000CN	RH5-3078-000CN	1
5; Figure 244.	ADF sensor PCB assembly	RH5-3079-000CN	RH5-3079-000CN	RH5-3079-000CN	1
6; Figure 244.	Power supply assembly	RG1-4153-000CN	RG1-4153-000CN	RG1-4153-000CN	1
7; Figure 244.	ADF analog processor PCB assembly	RH5-3082-000CN	Not orderable	RH5-3082-000CN	1
8; Figure 244.	Inverter PCB assembly	RH7-3065-000CN	Not orderable	Not orderable	1
9; Figure 244.	ADF width sensor assembly	RG5-6274-000CN	RG5-6274-000CN	RG5-6274-000CN	1

# Alphabetical parts list

**Note**

<sup>1</sup> HP LJ 9000mfp/9000Lmfp component description

<sup>2</sup> HP LJ 9040mfp/9050mfp/9500mfp component description

**Table 87. Alphabetical parts list**

Ref	Description	HP LJ 9000mfp HP LJ 9000Lmfp Part number	HP LJ 9040mfp HP LJ 9050mfp Part number	HP LJ 9500mfp Part number	Qty
18; Figure 243.	ADF analog processor PCB	RH5-3082-000CN	Not orderable	RH5-3082-000CN	1
7; Figure 244.	ADF analog processor PCB assembly	RH5-3082-000CN	Not orderable	Not orderable	1
16; Figure 234	ADF back cover assembly <sup>1</sup> ADF rear cover assembly <sup>2</sup>	RG5-6315-000CN	RG5-6315-000CN	RG5-6315-000CN	1
24; Figure 239.	ADF base cover assembly <sup>1</sup> Base, cover assembly <sup>2</sup>	RG5-6272-050CN	RG5-6272-050CN	RG5-6272-050CN	1
30; Figure 239.	ADF fan assembly	RG5-6312-000CN	RG5-6312-000CN	RG5-6312-000CN	1
27; Figure 239.	ADF intermediate PCB	RH5-3078-000CN	RH5-3078-000CN	RH5-3078-000CN	1
4; Figure 244.	ADF intermediate PCB assembly	RH5-3078-000CN	RH5-3078-000CN	RH5-3078-000CN	1
14; Figure 243.	ADF lamp assembly	RG5-6322-000CN	Not orderable	Not orderable	1
All; Figure 242.	ADF main assembly	RG5-7379-000CN	RG5-7379-000CN	RG5-7379-000CN	1
All; Figure 243.	ADF optical assembly	RG5-6307-000CN	RG5-6307-000CN	RG5-7380-000CN	1
17; Figure 239.	ADF optical unit filter <sup>1</sup> Cover, lamp right <sup>2</sup>	RF5-3850-000CN	RF5-3850-000CN	RF5-3850-000CN	1
4; Figure 234.	ADF output tray <sup>1</sup> Delivery tray assembly <sup>2</sup>	RG5-6316-000CN	RG5-6316-000CN	RG5-6316-000CN	1
24; Figure 242.	ADF sensor PCB assembly	RH5-3079-000CN	RH5-3079-000CN	RH5-3079-000CN	1
5; Figure 244.	ADF sensor PCB assembly	RH5-3079-000CN	RH5-3079-000CN	RH5-3079-000CN	1
26; Figure 239.	ADF width sensor assembly	RG5-6274-000CN	RG5-6274-000CN	RG5-6274-000CN	1
9; Figure 244.	ADF width sensor assembly	RG5-6274-000CN	RG5-6274-000CN	RG5-6274-000CN	1
3; Figure 240.	Arm, flapper front <sup>1</sup> Arm, flapper <sup>2</sup>	RF5-3688-000CN	RF5-3688-000CN	RF5-3688-000CN	1
2; Figure 240.	Arm, flapper rear <sup>1</sup> Arm, flapper rear <sup>2</sup>	RF5-3689-000CN	RF5-3689-000CN	RF5-3689-000CN	1
19; Figure 240.	Belt, separation <sup>1</sup> Belt, timing <sup>2</sup>	RB2-7988-000CN	RB2-7988-000CN	RB2-7988-000CN	4
16; Figure 243.	Cable, CCD	Not orderable	Not orderable	RH2-5453-000CN	1
29; Figure 239.	Cable, guide assembly	RG5-6311-000CN	RG5-6311-000CN	RG5-6311-000CN	1
5; Figure 232.	Control panel assembly	RG5-5734-020CN	5851-1838	5851-1838	1
2; Figure 232.	Control panel cable	RG5-5752-000CN	RG5-5752-000CN	RG5-5752-000CN	1
6; Figure 232.	Control panel overlay left	See Table 73.	See Table 73.	See Table 75.	1
7; Figure 232.	Control panel overlay right	See Table 73.	See Table 73.	See Table 75.	1
13; Figure 233.	Cover whiteboard <sup>1</sup> Cover, copyboard unit <sup>2</sup>	RF5-3695-000CN	RF5-3695-000CN	RF5-3695-000CN	1

**Table 87. Alphabetical parts list (continued)**

Ref	Description	HP LJ 9000mfp HP LJ 9000Lmfp Part number	HP LJ 9040mfp HP LJ 9050mfp Part number	HP LJ 9500mfp Part number	Qty
4; Figure 239.	Cover, ADF feeder <sup>1</sup> Cover, jam <sup>2</sup>	RB2-8040-000CN	RB2-8040-000CN	RB2-8040-000CN	1
7; Figure 239.	Cover, ADF front <sup>1</sup> Cover, front <sup>2</sup>	RB2-8048-000CN	RB2-8048-000CN	RB2-8048-000CN	1
4; Figure 242.	Cover, cable	Not orderable	RB2-8031-000CN	RB2-8031-000CN	3
6; Figure 234.	Cover, flatbed left <sup>1</sup> Cover, left <sup>2</sup>	RB2-8054-000CN	RB2-8054-000CN	RB2-8054-000CN	1
2; Figure 235.	Cover, flatbed lower front <sup>1</sup> Cover, front upper <sup>2</sup>	RB2-7934-000CN	RB2-7934-000CN	RB2-7934-000CN	1
4; Figure 235.	Cover, flatbed right <sup>1</sup> Cover, right <sup>2</sup>	RB2-8063-000CN	RB2-8063-000CN	RB2-8063-000CN	1
1; Figure 235.	Cover, flatbed upper front <sup>1</sup> Cover, front lower <sup>2</sup>	RB2-7933-000CN	RB2-7933-000CN	RB2-7933-000CN	1
1; Figure 235.	Cover, flatbed upper front <sup>1</sup> Cover, front lower <sup>2</sup>	RB2-7933-000CN	RB2-7933-000CN	RB2-7933-000CN	1
3; Figure 235.	Cover, glass mount	RB2-7935-000CN	RB2-7935-000CN	RB2-7935-000CN	2
29; Figure 238.	Cover, lens	RB2-7902-000CN	Not orderable	Not orderable	1
15; Figure 243.	Cover, lens	RB2-6307-000CN	Not orderable	Not orderable	1
12; Figure 234.	Cover, lower delivery roller <sup>1</sup> Guide, delivery unit <sup>2</sup>	RF5-3674-000CN	RF5-3674-000CN	RF5-3674-000CN	1
10; Figure 234.	CPB protectors <sup>1</sup> Cover, connector <sup>2</sup>	RB2-8060-000CN	RB2-8060-000CN	RB2-8060-000CN	2
30B; Figure 239.	Fan, ADF <sup>1</sup> Fan <sup>2</sup>	RH7-1486-000CN	RH7-1486-000CN	RH7-1486-000CN	1
38; Figure 240.	Feed roller assembly <sup>1</sup> Separation roller assembly <sup>2</sup>	RG5-6281-000CN	RG5-6281-000CN	RG5-6281-000CN	1
10; Figure 239.	Ferrite core	RB2-8678-000CN	RB2-8678-000CN	RB2-8678-000CN	1
505; Figure 241.	Flag, ADF open <sup>1</sup> Lever, open <sup>2</sup>	RB2-7964-000CN	RB2-7964-000CN	RB2-7964-000CN	1
48; Figure 241.	Flag, empty	RG5-6290-000CN	RG5-6290-000CN	RG5-6290-000CN	1
30; Figure 237.	Flatbed fan assembly <sup>1</sup> Fan assembly <sup>2</sup>	RG5-6318-000CN	RG5-6318-000CN	RG5-6318-000CN	1
14; Figure 235.	Flatbed glass <sup>1</sup> Copyboard glass unit <sup>2</sup>	RF5-3676-000CN	RF5-3676-000CN	RF5-3676-000CN	1
34; Figure 237.	Flatbed intermediate PCB	RH5-3073-000CN	RH5-3073-000CN	RH5-3073-000CN	1
2; Figure 244.	Flatbed intermediate PCB assy	RH5-3073-000CN	RH5-3073-000CN	RH5-3073-000CN	1
28; Figure 238.	Flatbed lamp assembly	RG5-6323-000CN	Not orderable	Not orderable	1
All; Figure 238.	Flatbed optical assembly	RG5-6263-000CN	RG5-6263-000CN	RG5-6263-000CN	1
25; Figure 237.	Flatbed sensor assembly	RG5-6259-000CN	RG5-7806-000CN	RG5-6259-000CN	1
24; Figure 243.	Flip-down glass assembly	Not orderable	Not orderable	RG5-6320-000CN	1
17A; Figure 237.	Fuse, 250V, 5A	VD7-0645-000CN	VD7-0645-000CN	VD7-0645-000CN	1
3; Figure 232.	Grounding cable	RG5-5736-000CN	RG5-5736-020CN	RG5-5992-000CN	1

**Table 87. Alphabetical parts list (continued)**

Ref	Description	HP LJ 9000mfp HP LJ 9000Lmfp Part number	HP LJ 9040mfp HP LJ 9050mfp Part number	HP LJ 9500mfp Part number	Qty
34; Figure 239.	Guide, back ADF tray <sup>1</sup> Guide, rear tray <sup>2</sup>	RF5-3682-000CN	RF5-3682-000CN	RF5-3682-000CN	1
35; Figure 239.	Guide, front tray	RF5-3698-000CN	RF5-3698-000CN	RF5-3698-000CN	1
5; Figure 239.	Guide, I/F 1	RB2-8046-000CN	RB2-8046-000CN	RB2-8046-000CN	1
6; Figure 239.	Guide, I/F 4	RB2-8047-000CN	RB2-8047-000CN	RB2-8047-000CN	1
11; Figure 239.	Guide, I/F 5	RB2-8681-000CN	RB2-8681-000CN	RB2-8681-000CN	1
12; Figure 239.	Guide, I/F 6	RB2-8682-000CN	RB2-8682-000CN	RB2-8682-000CN	1
27; Figure 242.	Handle <sup>1</sup> Knob <sup>2</sup>	RB2-8015-000CN	RB2-8015-000CN	RB2-8015-000CN	1
16A; Figure 234.	Hinge cover assembly	RG5-6317-000CN	RG5-6317-000CN	RG5-6317-000CN	2
15; Figure 239.	Holder, ADF stop <sup>1</sup> Holder, stop <sup>2</sup>	RB2-8693-000CN	RB2-8693-000CN	RB2-8693-000CN	1
8; Figure 232.	Holder, lock	RB2-6495-000CN	RB2-6495-000CN	RB2-6495-000CN	4
6; Figure 240.	Holder, separation	RB2-7989-000CN	RB2-7989-000CN	RB2-7989-000CN	3
5; Figure 240.	Holder, spring	RB2-7990-000CN	RB2-7990-000CN	RB2-7990-000CN	3
16C; Figure 241.	Holder, weight plate	RB2-7999-000CN	RB2-7999-000CN	RB2-7999-000CN	1
31; Figure 239.	I/F cable guide assembly	RG5-6313-000CN	RG5-6313-000CN	RG5-6313-000CN	1
26A; Figure 237.	Intermediate PCB	RH5-3074-000CN	RH5-7807-000CN	RH5-3074-000CN	1
1; Figure 244.	Intermediate PCB assembly	RH5-3074-000CN	RH5-3074-000CN	RH5-3074-000CN	1
26; Figure 237.	Intermediate PCB case	Not applicable	Not applicable	RH5-6260-000CN	1
27; Figure 238.	Inverter PCB assembly	RH7-3065-000CN	Not orderable	Not orderable	1
17; Figure 243.	Inverter PCB assembly	RH7-3065-000CN	Not orderable	Not orderable	1
8; Figure 244.	Inverter PCB assembly	RH7-3065-000CN	Not orderable	Not orderable	1
1; Figure 232.	Left upper cover assembly	RG5-5706-000CN	RG5-5706-000CN	RB2-7336-000CN	1
9; Figure 241.	Lever, empty	RB2-8002-000CN	RB2-8002-000CN	RB2-8002-000CN	1
26; Figure 242.	Lever, handle <sup>1</sup> Lever, knob <sup>2</sup>	RB2-8017-000CN	RB2-8017-000CN	RB2-8017-000CN	1
32; Figure 239.	Lever, sensor	RB2-7943-000CN	RB2-7943-000CN	RB2-7943-000CN	1
40; Figure 236.	Lower delivery roller	RB2-7884-000CN	RB2-7884-000CN	RB2-7884-000CN	4
27; Figure 236.	Lower delivery roller assembly <sup>1</sup> Delivery roller assembly <sup>2</sup>	RG5-6266-000CN	RG5-6266-000CN	RG5-6266-000CN	1
506; Figure 241.	Lower registration roller assembly <sup>1</sup> Registration roller assembly <sup>2</sup>	RG5-6277-000CN	RG5-6277-000CN	RG5-6277-000CN	1
25A; Figure 241.	Micro-switch	WC4-5175-000CN	WC4-5175-000CN	WC4-5175-000CN	1
47C; Figure 241.	Motor, delivery, 24vdc <sup>1</sup> Motor, 24vdc <sup>2</sup>	RH7-1487-000CN	RH7-1487-000CN	RH7-1487-000CN	1
18; Figure 236.	Motor, flatbed, 24vdc <sup>1</sup> Motor, 24vdc <sup>2</sup>	RH7-1485-000CN	RH7-1485-000CN	RH7-1485-000CN	1
29D; Figure 241.	Motor, pickup 24vdc <sup>1</sup> Motor, 24vdc <sup>2</sup>	RH7-1488-000CN	RH7-1488-000CN	RH7-1488-000CN	1
10; Figure 235.	Mount, glass 13	RB2-7928-000CN	RB2-7928-000CN	RB2-7928-000CN	3

**Table 87. Alphabetical parts list (continued)**

Ref	Description	HP LJ 9000mfp HP LJ 9000Lmfp Part number	HP LJ 9040mfp HP LJ 9050mfp Part number	HP LJ 9500mfp Part number	Qty
9; Figure 235.	Mount, glass alignment <sup>1</sup> Mount, glass 3 <sup>2</sup>	RB2-7927-000CN	RB2-7927-000CN	RB2-7927-000CN	1
All; Figure 240. All; Figure 241.	Paper pickup assembly	RG5-6275-000CN	RG5-6275-000CN	RG5-6275-000CN	1
23B; Figure 237.	Photo interrupter, TLP1241	WG8-5362-000CN	Not applicable	WG8-5362-000CN	1
33; Figure 239.	Photo-interrupter, TLP1241	WG8-5362-000CN	WG8-5362-000CN	WG8-5362-000CN	2
45A; Figure 240.	Photo-interrupter, TLP1241	WG8-5362-000CN	WG8-5362-000CN	WG8-5362-000CN	
40; Figure 240.	Pickup (D-roller) assembly <sup>1</sup> Pickup roller assembly <sup>2</sup>	RG5-6283-000CN	RG5-6283-000CN	RG5-6283-000CN	1
45; Figure 240.	Pickup sensor assembly	RG5-6285-000CN	RG5-6285-000CN	RG5-6285-000CN	1
24; Figure 235.	Plate, shaft ground <sup>1</sup> Plate, slide shaft <sup>2</sup>	RB2-7920-000CN	RB2-7920-000CN	RB2-7920-000CN	1
17; Figure 237. 6; Figure 244.	Power supply assembly	RG1-4153-000CN	RG1-4153-000CN	RG1-4153-000CN	1
4; Figure 232.	Power supply cable (HP LJ 9000mfp/9000Lmfp/9040mfp/ 9050mfp) AC cable (HP CLJ 9500mfp)	RG5-5735-000CN	RG5-5735-000CN	RG5-5991-000CN	1
18; Figure 239.	Processing PCB cable	RH2-5456-000CN	RH2-5456-000CN	RH2-5456-000CN	1
23; Figure 242.	Registration sensor holder assy	RG5-6305-000CN	RG5-6305-000CN	RG5-6305-000CN	1
40A; Figure 240.	Roller, pickup	RB2-7961-000CN	RB2-7961-000CN	RB2-7961-000CN	1
503; Figure 240.	Roller, upper delivery assembly <sup>1</sup> Roller delivery <sup>2</sup>	RB2-7950-000CN	RB2-7950-000CN	RB2-7950-000CN	1
22; Figure 237.	Scanner controller cable	RG5-6257-000CN	RG5-6257-000CN	RG5-6257-000CN	1
37; Figure 237.	Scanner controller PCB	RH5-3075-000CN	RH5-3075-090CN	RH5-3122-000CN	1
3; Figure 244.	Scanner controller PCB assy	RH5-3075-090CN	RH5-3075-090CN	RH5-3122-000CN	1
23; Figure 237.	Sensor crossmember assembly	RG5-6258-000CN	RG5-6258-000CN	RG5-6258-000CN	1
23A; Figure 237.	Sensor, document size	FH7-7423-000CN	Not applicable	FH7-7423-000CN	3
25A; Figure 237.	Sensor, document size	FH7-7424-000CN	Not applicable	FH7-7424-000CN	1
28; Figure 242.	Shaft, handle <sup>1</sup> Shaft, knob <sup>2</sup>	RB2-8016-000CN	RB2-8016-000CN	RB2-8016-000CN	1
502; Figure 240.	Shutter assembly	RG5-6286-000CN	RG5-6286-000CN	RG5-6286-000CN	1
34; Figure 241.	Solenoid, shutter <sup>1</sup> Solenoid <sup>2</sup>	RH7-5312-000CN	RH7-5312-000CN	RH7-5312-000CN	1
38; Figure 236.	Spring, compression	RS6-2492-000CN	RS6-2492-000CN	RS6-2492-000CN	2
4; Figure 240.	Spring, leaf	RB2-7991-000CN	RB2-7991-000CN	RB2-7991-000CN	3
22; Figure 241.	Spring, tension	RS6-2496-000CN	RS6-2496-000CN	RS6-2496-000CN	1
23; Figure 241.	Spring, tension	RS6-2498-000CN	RS6-2498-000CN	RS6-2498-000CN	1
33; Figure 241.	Spring, tension	RS6-2496-000CN	RS6-2496-000CN	RS6-2496-000CN	1
29; Figure 242.	Spring, tension	RS6-2503-000CN	RS6-2503-000CN	RS6-2503-000CN	2
504; Figure 240.	Static charge eliminator	RB2-7970-000CN	RB2-7970-000CN	RB2-7970-000CN	1

**Table 87. Alphabetical parts list (continued)**

Ref	Description	HP LJ 9000mfp HP LJ 9000Lmfp Part number	HP LJ 9040mfp HP LJ 9050mfp Part number	HP LJ 9500mfp Part number	Qty
24; Figure 242.	Timing sensor holder assembly	RG5-6306-000CN	RG5-6306-000CN	RG5-6306-000CN	3
35; Figure 239.	Tray, rack	RB2-7939-000CN	RB2-7939-000CN	RB2-7939-000CN	1
22; Figure 242.	Upper registration guide assy <sup>1</sup> Registration guide assembly <sup>2</sup>	RG5-6304-000CN	RG5-6304-000CN	RG5-6304-000CN	4
16; Figure 241.	Weight assembly	RG5-6298-000CN	RG5-6298-000CN	RG5-6298-000CN	1
12; Figure 240.	Weight solenoid assembly	RG5-6289-000CN	RG5-6289-000CN	RG5-6289-000CN	1
<sup>1</sup> HP LaserJet 9000mfp/9000Lmfp component description <sup>2</sup> HP LaserJet 9040mfp/9050mfp/9500mfp component description					

## Numerical parts list

<sup>1</sup> HP LJ 9000mfp/9000Lmfp component description

<sup>2</sup> HP LJ 9040mfp/9050mfp/9500mfp component description

**Table 88. Numerical parts list**

Ref	Description	Part number	Qty	MFP
5; Figure 232.	Control panel assembly	5851-1838	1	HP LJ 9040mfp/9050mfp HP CLJ 9500mfp
23A; Figure 237.	Sensor, document size	FH7-7423-000CN	3	HP LJ 9000mfp/9000Lmfp HP CLJ 9500mfp
25A; Figure 237.	Sensor, document size	FH7-7424-000CN	1	HP LJ 9000mfp/9000Lmfp HP CLJ 9500mfp
15; Figure 243.	Cover, lens	RB2-6307-000CN	1	HP LJ 9000mfp/9000Lmfp
8; Figure 232.	Holder, lock	RB2-6495-000CN	4	HP LJ 9000mfp/9000Lmfp HP LJ 9040mfp/9050mfp HP CLJ 9500mfp
1; Figure 232.	Left upper cover assembly	RB2-7336-000CN	1	HP CLJ 9500mfp
40; Figure 236.	Lower delivery roller	RB2-7884-000CN	4	HP LJ 9000mfp/9000Lmfp HP LJ 9040mfp/9050mfp HP CLJ 9500mfp
29; Figure 238.	Cover, lens	RB2-7902-000CN	1	HP LJ 9000mfp/9000Lmfp
24; Figure 235.	Plate, shaft ground <sup>1</sup> Plate, slide shaft <sup>2</sup>	RB2-7920-000CN	1	HP LJ 9000mfp/9000Lmfp HP LJ 9040mfp/9050mfp HP CLJ 9500mfp
9; Figure 235.	Mount, glass alignment <sup>1</sup> Mount, glass 3 <sup>2</sup>	RB2-7927-000CN	1	HP LJ 9000mfp/9000Lmfp HP LJ 9040mfp/9050mfp HP CLJ 9500mfp
10; Figure 235.	Mount, glass 13	RB2-7928-000CN	3	HP LJ 9000mfp/9000Lmfp HP LJ 9040mfp/9050mfp HP CLJ 9500mfp
1; Figure 235.	Cover, flatbed upper front <sup>1</sup> Cover, front lower <sup>2</sup>	RB2-7933-000CN	1	HP LJ 9000mfp/9000Lmfp HP LJ 9040mfp/9050mfp HP CLJ 9500mfp
2; Figure 235.	Cover, flatbed lower front <sup>1</sup> Cover, front upper <sup>2</sup>	RB2-7934-000CN	1	HP LJ 9000mfp/9000Lmfp HP LJ 9040mfp/9050mfp HP CLJ 9500mfp
3; Figure 235.	Cover, glass mount	RB2-7935-000CN	2	HP LJ 9000mfp/9000Lmfp HP LJ 9040mfp/9050mfp HP CLJ 9500mfp
35; Figure 239.	Tray, rack	RB2-7939-000CN	1	HP LJ 9000mfp/9000Lmfp HP LJ 9040mfp/9050mfp HP CLJ 9500mfp
32; Figure 239.	Lever, sensor	RB2-7943-000CN	1	HP LJ 9000mfp/9000Lmfp HP LJ 9040mfp/9050mfp HP CLJ 9500mfp
503; Figure 240.	Roller, upper delivery assembly <sup>1</sup> Roller delivery <sup>2</sup>	RB2-7950-000CN	1	HP LJ 9000mfp/9000Lmfp HP LJ 9040mfp/9050mfp HP CLJ 9500mfp

**Table 88. Numerical parts list (continued)**

Ref	Description	Part number	Qty	MFP
40A; Figure 240.	Roller, pickup	RB2-7961-000CN	1	HP LJ 9000mfp/9000Lmfp HP LJ 9040mfp/9050mfp HP CLJ 9500mfp
505; Figure 241.	Flag, ADF open <sup>1</sup> Lever, open <sup>2</sup>	RB2-7964-000CN	1	HP LJ 9000mfp/9000Lmfp HP LJ 9040mfp/9050mfp HP CLJ 9500mfp
504; Figure 240.	Static charge eliminator	RB2-7970-000CN	1	HP LJ 9000mfp/9000Lmfp HP LJ 9040mfp/9050mfp HP CLJ 9500mfp
19; Figure 240.	Belt, separation <sup>1</sup> Belt, timing <sup>2</sup>	RB2-7988-000CN	4	HP LJ 9000mfp/9000Lmfp HP LJ 9040mfp/9050mfp HP CLJ 9500mfp
6; Figure 240.	Holder, separation	RB2-7989-000CN	3	HP LJ 9000mfp/9000Lmfp HP LJ 9040mfp/9050mfp HP CLJ 9500mfp
5; Figure 240.	Holder, spring	RB2-7990-000CN	3	HP LJ 9000mfp/9000Lmfp HP LJ 9040mfp/9050mfp HP CLJ 9500mfp
4; Figure 240.	Spring, leaf	RB2-7991-000CN	3	HP LJ 9000mfp/9000Lmfp HP LJ 9040mfp/9050mfp HP CLJ 9500mfp
16C; Figure 241.	Holder, weight plate	RB2-7999-000CN	1	HP LJ 9000mfp/9000Lmfp HP LJ 9040mfp/9050mfp HP CLJ 9500mfp
9; Figure 241.	Lever, empty	RB2-8002-000CN	1	HP LJ 9000mfp/9000Lmfp HP LJ 9040mfp/9050mfp HP CLJ 9500mfp
27; Figure 242.	Handle <sup>1</sup> Knob <sup>2</sup>	RB2-8015-000CN	1	HP LJ 9000mfp/9000Lmfp HP LJ 9040mfp/9050mfp HP CLJ 9500mfp
28; Figure 242.	Shaft, handle <sup>1</sup> Shaft, knob <sup>2</sup>	RB2-8016-000CN	1	HP LJ 9000mfp/9000Lmfp HP LJ 9040mfp/9050mfp HP CLJ 9500mfp
26; Figure 242.	Lever, handle <sup>1</sup> Lever, knob <sup>2</sup>	RB2-8017-000CN	1	HP LJ 9000mfp/9000Lmfp HP LJ 9040mfp/9050mfp HP CLJ 9500mfp
4; Figure 242.	Cover, cable	RB2-8031-000CN	3	HP LJ 9040mfp/9050mfp HP CLJ 9500mfp
4; Figure 239.	Cover, ADF feeder <sup>1</sup> Cover, jam <sup>2</sup>	RB2-8040-000CN	1	HP LJ 9000mfp/9000Lmfp HP LJ 9040mfp/9050mfp HP CLJ 9500mfp
5; Figure 239.	Guide, I/F 1	RB2-8046-000CN	1	HP LJ 9000mfp/9000Lmfp HP LJ 9040mfp/9050mfp HP CLJ 9500mfp
6; Figure 239.	Guide, I/F 4	RB2-8047-000CN	1	HP LJ 9000mfp/9000Lmfp HP LJ 9040mfp/9050mfp HP CLJ 9500mfp
7; Figure 239.	Cover, ADF front <sup>1</sup> Cover, front <sup>2</sup>	RB2-8048-000CN	1	HP LJ 9000mfp/9000Lmfp HP LJ 9040mfp/9050mfp HP CLJ 9500mfp

**Table 88. Numerical parts list (continued)**

Ref	Description	Part number	Qty	MFP
6; Figure 234.	Cover, flatbed left <sup>1</sup> Cover, left <sup>2</sup>	RB2-8054-000CN	1	HP LJ 9000mfp/9000Lmfp HP LJ 9040mfp/9050mfp HP CLJ 9500mfp
10; Figure 234.	CPB protectors <sup>1</sup> Cover, connector <sup>2</sup>	RB2-8060-000CN	2	HP LJ 9000mfp/9000Lmfp HP LJ 9040mfp/9050mfp HP CLJ 9500mfp
4; Figure 235.	Cover, flatbed right <sup>1</sup> Cover, right <sup>2</sup>	RB2-8063-000CN	1	HP LJ 9000mfp/9000Lmfp HP LJ 9040mfp/9050mfp HP CLJ 9500mfp
10; Figure 239.	Ferrite core	RB2-8678-000CN	1	HP LJ 9000mfp/9000Lmfp HP LJ 9040mfp/9050mfp HP CLJ 9500mfp
11; Figure 239.	Guide, I/F 5	RB2-8681-000CN	1	HP LJ 9000mfp/9000Lmfp HP LJ 9040mfp/9050mfp HP CLJ 9500mfp
12; Figure 239.	Guide, I/F 6	RB2-8682-000CN	1	HP LJ 9000mfp/9000Lmfp HP LJ 9040mfp/9050mfp HP CLJ 9500mfp
15; Figure 239.	Holder, ADF stop <sup>1</sup> Holder, stop <sup>2</sup>	RB2-8693-000CN	1	HP LJ 9000mfp/9000Lmfp HP LJ 9040mfp/9050mfp HP CLJ 9500mfp
12; Figure 234.	Cover, lower delivery roller <sup>1</sup> Guide, delivery unit <sup>2</sup>	RF5-3674-000CN	1	HP LJ 9000mfp/9000Lmfp HP LJ 9040mfp/9050mfp HP CLJ 9500mfp
14; Figure 235.	Flatbed glass <sup>1</sup> Copyboard glass unit <sup>2</sup>	RF5-3676-000CN	1	HP LJ 9000mfp/9000Lmfp HP LJ 9040mfp/9050mfp HP CLJ 9500mfp
34; Figure 239.	Guide, back ADF tray <sup>1</sup> Guide, rear tray <sup>2</sup>	RF5-3682-000CN	1	HP LJ 9000mfp/9000Lmfp HP LJ 9040mfp/9050mfp HP CLJ 9500mfp
3; Figure 240.	Arm, flapper front <sup>1</sup> Arm, flapper <sup>2</sup>	RF5-3688-000CN	1	HP LJ 9000mfp/9000Lmfp HP LJ 9040mfp/9050mfp HP CLJ 9500mfp
2; Figure 240.	Arm, flapper rear	RF5-3689-000CN	1	HP LJ 9000mfp/9000Lmfp HP LJ 9040mfp/9050mfp HP CLJ 9500mfp
13; Figure 233.	Cover whiteboard <sup>1</sup> Cover, copyboard unit <sup>2</sup>	RF5-3695-000CN	1	HP LJ 9000mfp/9000Lmfp HP LJ 9040mfp/9050mfp HP CLJ 9500mfp
35; Figure 239.	Guide, front tray	RF5-3698-000CN	1	HP LJ 9000mfp/9000Lmfp HP LJ 9040mfp/9050mfp HP CLJ 9500mfp
17; Figure 239.	ADF optical unit filter <sup>1</sup> Cover, lamp right <sup>2</sup>	RF5-3850-000CN	1	HP LJ 9000mfp/9000Lmfp HP LJ 9040mfp/9050mfp HP CLJ 9500mfp
17; Figure 237. 6; Figure 244.	Power supply assembly	RG1-4153-000CN	1	HP LJ 9000mfp/9000Lmfp HP LJ 9040mfp/9050mfp HP CLJ 9500mfp
1; Figure 232.	Left upper cover assembly	RG5-5706-000CN	1	HP LJ 9000mfp/9000Lmfp HP LJ 9040mfp/9050mfp
5; Figure 232.	Control panel assembly	RG5-5734-020CN	1	HP LJ 9000mfp/9000Lmfp

**Table 88. Numerical parts list (continued)**

Ref	Description	Part number	Qty	MFP
4; Figure 232.	Power supply cable	RG5-5735-000CN	1	HP LJ 9000mfp/9000Lmfp HP LJ 9040mfp/9050mfp
3; Figure 232.	Grounding cable	RG5-5736-000CN	1	HP LJ 9000mfp/9000Lmfp
3; Figure 232.	Grounding cable	RG5-5736-020CN	1	HP LJ 9040mfp/9050mfp
2; Figure 232.	Control panel cable	RG5-5752-000CN	1	HP LJ 9000mfp/9000Lmfp HP LJ 9040mfp/9050mfp HP CLJ 9500mfp
4; Figure 232.	Power supply cable	RG5-5991-000CN	1	HP CLJ 9500mfp
3; Figure 232.	Grounding cable	RG5-5992-000CN	1	HP CLJ 9500mfp
22; Figure 237.	Scanner controller cable	RG5-6257-000CN	1	HP LJ 9000mfp/9000Lmfp HP LJ 9040mfp/9050mfp HP CLJ 9500mfp
23; Figure 237.	Sensor crossmember assembly	RG5-6258-000CN	1	HP LJ 9000mfp/9000Lmfp HP LJ 9040mfp/9050mfp HP CLJ 9500mfp
25; Figure 237.	Flatbed sensor assembly	RG5-6259-000CN	1	HP LJ 9000mfp/9000Lmfp HP CLJ 9500mfp
All; Figure 238.	Flatbed optical assembly	RG5-6263-000CN	1	HP LJ 9000mfp/9000Lmfp HP LJ 9040mfp/9050mfp HP CLJ 9500mfp
27; Figure 236.	Lower delivery roller assembly <sup>1</sup> Delivery roller assembly <sup>2</sup>	RG5-6266-000CN	1	HP LJ 9000mfp/9000Lmfp HP LJ 9040mfp/9050mfp HP CLJ 9500mfp
24; Figure 239.	ADF base cover assembly <sup>1</sup> Base, cover assembly <sup>2</sup>	RG5-6272-050CN	1	HP LJ 9000mfp/9000Lmfp HP LJ 9040mfp/9050mfp HP CLJ 9500mfp
26; Figure 239. 9; Figure 244.	ADF width sensor assembly	RG5-6274-000CN	1	HP LJ 9000mfp/9000Lmfp HP LJ 9040mfp/9050mfp HP CLJ 9500mfp
All; Figure 240. All; Figure 241.	Paper pickup assembly	RG5-6275-000CN	1	HP LJ 9000mfp/9000Lmfp HP LJ 9040mfp/9050mfp HP CLJ 9500mfp
506; Figure 241.	Lower registration roller assembly <sup>1</sup> Registration roller assembly <sup>2</sup>	RG5-6277-000CN	1	HP LJ 9000mfp/9000Lmfp HP LJ 9040mfp/9050mfp HP CLJ 9500mfp
38; Figure 240.	Feed roller assembly <sup>1</sup> Separation roller assembly <sup>2</sup>	RG5-6281-000CN	1	HP LJ 9000mfp/9000Lmfp HP LJ 9040mfp/9050mfp HP CLJ 9500mfp
40; Figure 240.	Pickup (D-roller) assembly <sup>1</sup> Pickup roller assembly <sup>2</sup>	RG5-6283-000CN	1	HP LJ 9000mfp/9000Lmfp HP LJ 9040mfp/9050mfp HP CLJ 9500mfp
45; Figure 240.	Pickup sensor assembly	RG5-6285-000CN	1	HP LJ 9000mfp/9000Lmfp HP LJ 9040mfp/9050mfp HP CLJ 9500mfp
502; Figure 240.	Shutter assembly	RG5-6286-000CN	1	HP LJ 9000mfp/9000Lmfp HP LJ 9040mfp/9050mfp HP CLJ 9500mfp
12; Figure 240.	Weight solenoid assembly	RG5-6289-000CN	1	HP LJ 9000mfp/9000Lmfp HP LJ 9040mfp/9050mfp HP CLJ 9500mfp

**Table 88. Numerical parts list (continued)**

Ref	Description	Part number	Qty	MFP
48; Figure 241.	Flag, empty	RG5-6290-000CN	1	HP LJ 9000mfp/9000Lmfp HP LJ 9040mfp/9050mfp HP CLJ 9500mfp
16; Figure 241.	Weight assembly	RG5-6298-000CN	1	HP LJ 9000mfp/9000Lmfp HP LJ 9040mfp/9050mfp HP CLJ 9500mfp
22; Figure 242.	Upper registration guide assy <sup>1</sup> Registration guide assembly <sup>2</sup>	RG5-6304-000CN	4	HP LJ 9000mfp/9000Lmfp HP LJ 9040mfp/9050mfp HP CLJ 9500mfp
23; Figure 242.	Registration sensor holder assy	RG5-6305-000CN	1	HP LJ 9000mfp/9000Lmfp HP LJ 9040mfp/9050mfp HP CLJ 9500mfp
24; Figure 242.	Timing sensor holder assembly	RG5-6306-000CN	3	HP LJ 9000mfp/9000Lmfp HP LJ 9040mfp/9050mfp HP CLJ 9500mfp
All; Figure 243.	ADF optical assembly	RG5-6307-000CN	1	HP LJ 9000mfp/9000Lmfp HP LJ 9040mfp/9050mfp
29; Figure 239.	Cable, guide assembly	RG5-6311-000CN	1	HP LJ 9000mfp/9000Lmfp HP LJ 9040mfp/9050mfp HP CLJ 9500mfp
30; Figure 239.	ADF fan assembly	RG5-6312-000CN	1	HP LJ 9000mfp/9000Lmfp HP LJ 9040mfp/9050mfp HP CLJ 9500mfp
31; Figure 239.	I/F cable guide assembly	RG5-6313-000CN	1	HP LJ 9000mfp/9000Lmfp HP LJ 9040mfp/9050mfp HP CLJ 9500mfp
16; Figure 234.	ADF back cover assembly <sup>1</sup> ADF rear cover assembly <sup>2</sup>	RG5-6315-000CN	1	HP LJ 9000mfp/9000Lmfp HP LJ 9040mfp/9050mfp HP CLJ 9500mfp
4; Figure 234.	ADF output tray <sup>1</sup> Delivery tray assembly <sup>2</sup>	RG5-6316-000CN	1	HP LJ 9000mfp/9000Lmfp HP LJ 9040mfp/9050mfp HP CLJ 9500mfp
16A; Figure 234.	Hinge cover assembly	RG5-6317-000CN	2	HP LJ 9000mfp/9000Lmfp HP LJ 9040mfp/9050mfp HP CLJ 9500mfp
30; Figure 237.	Flatbed fan assembly <sup>1</sup> Fan assembly <sup>2</sup>	RG5-6318-000CN	1	HP LJ 9000mfp/9000Lmfp HP LJ 9040mfp/9050mfp HP CLJ 9500mfp
24; Figure 243.	Flip-down glass assembly	RG5-6320-000CN	1	HP CLJ 9500mfp
14; Figure 243.	ADF lamp assembly	RG5-6322-000CN	1	HP LJ 9000mfp/9000Lmfp
28; Figure 238.	Flatbed lamp assembly	RG5-6323-000CN	1	HP LJ 9000mfp/9000Lmfp
All; Figure 242.	ADF main assembly	RG5-7379-000CN	1	HP LJ 9000mfp/9000Lmfp HP LJ 9040mfp/9050mfp HP CLJ 9500mfp
All; Figure 243.	ADF optical assembly	RG5-7380-000CN	1	HP CLJ 9500mfp
25; Figure 237.	Flatbed sensor assembly	RG5-7806-000CN	1	HP LJ 9040mfp/9050mfp
16; Figure 243.	Cable, CCD	RH2-5453-000CN	1	HP CLJ 9500mfp
18; Figure 239.	Processing PCB cable	RH2-5456-000CN	1	HP LJ 9000mfp/9000Lmfp HP LJ 9040mfp/9050mfp HP CLJ 9500mfp

**Table 88. Numerical parts list (continued)**

Ref	Description	Part number	Qty	MFP
34; Figure 237. 2; Figure 244.	Flatbed intermediate PCB	RH5-3073-000CN	1	HP LJ 9000mfp/9000Lmfp HP LJ 9040mfp/9050mfp HP CLJ 9500mfp
26A; Figure 237. 1; Figure 244.	Intermediate PCB	RH5-3074-000CN	1	HP LJ 9000mfp/9000Lmfp HP CLJ 9500mfp
37; Figure 237. 3; Figure 244.	Scanner controller PCB	RH5-3075-000CN	1	HP LJ 9000mfp/9000Lmfp
37; Figure 237. 3; Figure 244.	Scanner controller PCB	RH5-3075-090CN	1	HP LJ 9040mfp/9050mfp
27; Figure 239. 4; Figure 244.	ADF intermediate PCB	RH5-3078-000CN	1	HP LJ 9000mfp/9000Lmfp HP LJ 9040mfp/9050mfp HP CLJ 9500mfp
24; Figure 242. 5; Figure 244.	ADF sensor PCB assembly	RH5-3079-000CN	1	HP LJ 9000mfp/9000Lmfp HP LJ 9040mfp/9050mfp HP CLJ 9500mfp
7; Figure 244. 18; Figure 243.	ADF analog processor PCB	RH5-3082-000CN	1	HP LJ 9000mfp/9000Lmfp HP CLJ 9500mfp
37; Figure 237. 3; Figure 244.	Scanner controller PCB	RH5-3122-000CN	1	HP CLJ 9500mfp
26; Figure 237.	Intermediate PCB case	RH5-6260-000CN	1	HP CLJ 9500mfp
26A; Figure 237.	Intermediate PCB	RH5-7807-000CN	1	HP LJ 9040mfp/9050mfp
18; Figure 236.	Motor, flatbed, 24vdc <sup>1</sup> Motor, 24vdc <sup>2</sup>	RH7-1485-000CN	1	HP LJ 9000mfp/9000Lmfp HP LJ 9040mfp/9050mfp HP CLJ 9500mfp
30B; Figure 239.	Fan, ADF <sup>1</sup> Fan <sup>2</sup>	RH7-1486-000CN	1	HP LJ 9000mfp/9000Lmfp HP LJ 9040mfp/9050mfp HP CLJ 9500mfp
47C; Figure 241.	Motor, delivery, 24vdc <sup>1</sup> Motor, 24vdc <sup>2</sup>	RH7-1487-000CN	1	HP LJ 9000mfp/9000Lmfp HP LJ 9040mfp/9050mfp HP CLJ 9500mfp
29D; Figure 241.	Motor, pickup 24vdc <sup>1</sup> Motor, 24vdc <sup>2</sup>	RH7-1488-000CN	1	HP LJ 9000mfp/9000Lmfp HP LJ 9040mfp/9050mfp HP CLJ 9500mfp
17; Figure 243.	Inverter PCB assembly	RH7-3065-000CN	1	HP LJ 9000mfp/9000Lmfp
34; Figure 241.	Solenoid, shutter <sup>1</sup> Solenoid <sup>2</sup>	RH7-5312-000CN	1	HP LJ 9000mfp/9000Lmfp HP LJ 9040mfp/9050mfp HP CLJ 9500mfp
38; Figure 236.	Spring, compression	RS6-2492-000CN	2	HP LJ 9000mfp/9000Lmfp HP LJ 9040mfp/9050mfp HP CLJ 9500mfp
22; Figure 241. 33; Figure 241.	Spring, tension	RS6-2496-000CN	1	HP LJ 9000mfp/9000Lmfp HP LJ 9040mfp/9050mfp HP CLJ 9500mfp
23; Figure 241.	Spring, tension	RS6-2498-000CN	1	HP LJ 9000mfp/9000Lmfp HP LJ 9040mfp/9050mfp HP CLJ 9500mfp
29; Figure 242.	Spring, tension	RS6-2503-000CN	2	HP LJ 9000mfp/9000Lmfp HP LJ 9040mfp/9050mfp HP CLJ 9500mfp

**Table 88. Numerical parts list (continued)**

Ref	Description	Part number	Qty	MFP
6; Figure 232. 7; Figure 232.	Control panel overlay left Control panel overlay right	See Table 73. <sup>1</sup> See Table 75. <sup>2</sup>	1	HP LJ 9000mfp/9000Lmfp HP LJ 9040mfp/9050mfp HP CLJ 9500mfp
17A; Figure 237.P	Fuse, 250V, 5A	VD7-0645-000CN	1	HP LJ 9000mfp/9000Lmfp HP LJ 9040mfp/9050mfp HP CLJ 9500mfp
25A; Figure 241.	Micro-switch	WC4-5175-000CN	1	HP LJ 9000mfp/9000Lmfp HP LJ 9040mfp/9050mfp HP CLJ 9500mfp
23B; Figure 237. 33; Figure 239. 45A; Figure 240.	Photo interrupter, TLP1241	WG8-5362-000CN	1	HP LJ 9000mfp/9000LmfpHP LJ 9040mfp/9050mfp HP CLJ 9500mfp
<sup>1</sup> HP LaserJet 9000mfp/9000Lmfp component description				
<sup>2</sup> HP LaserJet 9040mfp/9050mfp/9500mfp component description				

# Index

## Numerics

8-bin mailbox, part number 320

## A

A4 paper settings 46, 69

accessories

diagnostics 58

ordering 316

part numbers 317

verifying installation 295

accounting information 299

acoustic emissions 24

address book, clearing 81

ADF (automatic document feeder)

angle detection operations 130

calibrating 271, 274

cleaning the delivery system 99

cleaning the glass strip 101

cleaning the rollers 103

counts, page 58, 85

diagrams 110

document detection operations 129

document exposure operations 131

document size detection operations 134

fan assembly, removing and replacing 205

fan operations 112

feed control operations 132

feeder sensors 135

heavy scaling calibration 281

height adjustment 287

jams 293

leading edge back calibration 279

leading edge front calibration 278

left side back calibration 277

left side front calibration 274

misfeeds 103

plain scaling calibration 280

power consumption 117

power supply operations 122

scanner assembly, diagrams and part numbers 339

scanning lamp, removing and replacing 184

scanning operations 115, 139

shading filter, removing and replacing 187

skew adjustments 289

skew detection operations 136

weight solenoid adjustment 292

ADF analog-processor PCB

operations 131

removing and replacing 207

ADF covers, removing and replacing

back 154

base-cover assembly 165

feeder 151

feeder detection switch 193

feeder handle 153

front 155

ADF duplex mode 116

ADF intermediate PCB

operations 131

removing and replacing 209

ADF inverter

operations 131

removing and replacing 208

ADF main assembly

diagrams and part numbers 347

removing and replacing 172

ADF optical unit

diagrams and part numbers 350

operations 110, 127

ADF simplex mode 116

ADF width sensor

calibrating 291

removing and replacing 210

adhesive labels, print modes 48, 72

agreements, service 30

air filter, locating 27

alignment, tray registration 48

alphabetical lists

messages 253

part numbers 353, 358

analog-processor PCB

operations 131

removing and replacing 207

angle detection, ADF 130

Appletalk settings 55

applications, changing settings from 36

assemblies

diagrams and part numbers 316, 328

ordering 28

removing and replacing 147

service approach 28

authorized resellers and support 30

auto continue settings 76

auto continue, settings 51

automatic document feeder (ADF). See ADF (automatic document feeder)

## B

background removal 66

backlight, control panel 118

belts, separation

assembly, removing and replacing 233

removing and replacing 236

bidirectional communication settings 52

billing, usage page information 299

binding edge settings 69

binding edge, settings 46

bins, setting default 45, 69

blank control panel display 247

blank pages

PCL settings 71

suppressing 47

block diagram, operations 114

both sides, printing on 46

box size

HP LJ 9000mfp/9000Lmfp 18

HP LJ 9500mfp 20

buttons, control panel

HP LJ 9000mfp/9000Lmfp 32

HP LJ 9500mfp 34

**C**

- cables
  - diagrams 328
  - troubleshooting 295
- calibration
  - glass scaling 284
  - heavy scaling, ADF 281
  - leading edge back, ADF 279
  - leading edge front, ADF 278
  - leading edge glass 283
  - left side back, ADF 277
  - left side front, ADF 274
  - left side glass 282
  - plain scaling, ADF 280
  - scanner controller PCB 309
  - settings 73
  - simplified 271
  - touch screen 268
  - width sensor, ADF 291
- cardstock
  - detection 64
  - fuser mode 48
  - print modes 72
  - tray calibration 281
- carriage lock 81, 127
- carriage return settings 47, 71
- cartridges
  - EconoMode 49
  - low 51, 76
  - out, settings 51
  - part numbers 317, 322
  - sample pages, printing 61
  - status page 298
- CD-ROMs, part numbers 321
- circuits
  - overcurrent/overvoltage detection 248
  - specifications 23, 117
- cleaning
  - ADF delivery system 99
  - ADF glass strip 101
  - ADF rollers 103
  - precautions 98
  - scanner glass 105
- cleaning kit, part numbers 322
- clearable warnings, settings 51, 76
- clock, setting 50, 74
- CMYK sample pages 61
- codes, Service menu 58
- cold reset paper size 58, 85, 128
- color
  - adjusting 72
  - band test 84
- color copy settings 40
- communications, settings 52
- component tests 83
- configuration page
  - HP Jetdirect 297
  - printing 42, 61
  - using 295
- Configure device menu 45, 64
- connectors, locating 27, 310
- control panel
  - backlight operations 118
  - blank, troubleshooting 247
  - calibration 268
  - Configure device menu 45, 64
  - Copying submenu 65
  - cover, removing and replacing 148, 150
  - date and time, setting 74
  - Diagnostics menu 58, 82
  - diagrams and part numbers 328
  - EIO submenu 53, 78
  - E-mail submenu 67
  - Enhancement submenu 66
  - event log, displaying 251
  - HP LJ 9000mfp/9000Lmfp 32
  - HP LJ 9500mfp 34
  - I/O submenu 52, 77
  - Information menu 61
  - language, selecting 52
  - language, setting 36, 76
  - menu map 42, 59
  - menus 59
  - messages, alphabetical list 253
  - messages, numerical list 255
  - messages, troubleshooting 249
  - Originals submenu 64
  - Paper handling menu 62
  - part numbers 318
  - PCL submenu 47, 70
  - Print quality submenu 48, 72
  - Printing submenu 45, 68
  - Resets submenu 57, 81
  - Retrieve job menu 42, 60
  - Sending submenu 66
  - Service menu 58, 85, 266
  - settings 36
  - System setup submenu 50, 74
  - testing 84
- copies
  - number of, setting default 45, 68
  - viewing count 58, 85
- Copy connect card 26
- copy processor board (CPB)
  - components 138
  - data output types 137
  - document detection operations 129
  - LEDs, status 140, 142, 262
  - LEDs, troubleshooting 261
  - operations 114, 139
  - power supply 122
  - removing and replacing 158
  - troubleshooting 260
- copying
  - background removal 66
  - color, settings 40
  - Originals submenu 64
  - system settings 75
- Copying submenu 65
- cost accounting information 299
- country of origin 22
- counts, page 58, 85, 299
- Courier font settings 46, 69

- covers
  - ADF back, removing and replacing 154
  - ADF base assembly, removing and replacing 165
  - ADF feeder detection switch, removing and replacing 193
  - ADF feeder handle, removing and replacing 153
  - ADF feeder, removing and replacing 151
  - ADF front, removing and replacing 155
  - control panel, removing and replacing 148, 150
  - delivery roller, removing and replacing 156
  - diagrams 328, 329
  - flatbed back, removing and replacing 160
  - flatbed left, removing and replacing 162
  - flatbed lower front, removing and replacing 164
  - flatbed rail, removing and replacing 159
  - flatbed right, removing and replacing 161
  - flatbed upper front, removing and replacing 163
  - part numbers 329
  - white board, removing and replacing 157
- CPU operations 124
- critical messages 252
- current capacity 23, 117
- custom media
  - default sizes 68
  - settings 63
  - tray settings 45
- customer support
  - HP PartnerCare 30
  - phone numbers 28
  - websites 29
- D**
  - dark setting, toner density 49
  - data transmission settings 52
  - date, setting
    - fax 39
    - MFP 50, 74
  - dc controller
    - operations 114, 122
    - part numbers 317
    - troubleshooting 247
  - default settings
    - number of copies 68
    - restoring 57, 81
    - selecting 36
  - defects, image 302
  - delivery motor
    - operations 112, 132
    - removing and replacing 198
  - delivery rollers
    - cover, removing and replacing 156
    - diagrams 111
    - lower, removing and replacing 231
    - upper, removing and replacing 232
  - demo page, printing 61
  - density settings 49
  - diagnostics
    - menu 58, 82
    - preliminary checks 246
    - service level 265, 266
    - user/service level 264
  - Diagnostics menu 58, 82
  - diagrams
    - assemblies 316
    - wiring 312
  - digital sending
    - E-mail submenu 67
    - Originals submenu 64
    - resolution 67
    - Sending submenu 66
    - system settings 75
  - DIMMs
    - part numbers 319
    - verifying installation 295
  - directory file page
    - printing 42, 61
    - using 300
  - disk
    - file directory page 61, 300
    - job retention limit, setting 74
    - locating 26
    - part numbers 323
  - DLC/LLC settings 55, 79
  - document exposure operations
    - ADF 131
    - flatbed 125
  - document size detection operations
    - ADF 134
    - flatbed 128
  - documentation
    - ordering 316
    - part numbers 317, 324
  - documentation, part numbers 320
  - dots per inch (dpi) settings 48
  - double-sided printing 46
  - downloading
    - drivers 29
    - firmware updates 87
  - dpi (dots per inch) settings 48
  - draft printing 49
  - drivers, Web sites 29
  - drums, part numbers 322
  - duplex mode 116
  - duplexer
    - Install guide 320
    - operations 110, 127
    - part number 320
    - part numbers 323
    - settings 46, 69
- E**
  - EconoMode 49
  - edge-to-edge printing 46
  - EEPROM operations 124
  - EIO submenu 53, 78
  - electrical specifications 23, 117
  - electrostatic discharge (ESD) precautions 147
  - e-mail settings 38
  - E-mail submenu 67
  - energy consumption 23, 117
  - Enhancement submenu 66
  - envelopes
    - default image size, setting 45
    - default size 68
    - print modes 72
    - tray settings 62
  - environment, acclimating to 246
  - environmental specifications 24
  - error messages
    - alphabetical list 253
    - event log 82, 249
    - numerical list 255
    - settings 51, 76
    - types of 252

- ESD (electrostatic discharge) precautions 147
- Ethernet, frame type settings 79
- event log
  - clearing 58, 85
  - configuration page 296
  - description 249
  - printing 58, 82, 249
  - viewing 58, 251
- exchange program 28
- exposure operations
  - ADF 131
  - flatbed 125
- F**
- face-up tray 108
- factory default settings
  - about 36
  - restoring 57, 81
- fans
  - ADF assembly, removing and replacing 205
  - flatbed, removing and replacing 206
  - operations 124
  - troubleshooting 247
- Fast InfraRed Connect 26, 319
- fasteners, types of 326
- FastRes 48
- fax connector, locating 27
- fax settings 39
- feed roller
  - ADF operations 133
  - assembly, diagrams 111
  - removing and replacing 224
- feeder cover, ADF
  - handle, removing and replacing 153
  - removing and replacing 151
- feeding problems, ADF 103, 293
- field replaceable units (FRUs)
  - part numbers 327
  - product, service, and exchange numbers 317
  - removing and replacing 147
  - service approach 28
- file directory page
  - printing 42, 61
  - using 300
- filter, locating 27
- firmware updates
  - Macintosh 91
  - messages received during 94
  - part numbers 318
  - troubleshooting 95
  - UNIX 89
  - Web sites 29
  - Windows, FTP 90
  - Windows, local port 88
  - Windows, LPR commands 93
  - Windows, network 89
- flatbed covers, removing and replacing
  - back 160
  - left 162
  - lower front 164
  - rail 159
  - right 161
  - upper front 163
- flatbed fan assembly
  - operations 112
  - removing and replacing 206
- flatbed intermediate PCB operations 125
- flatbed inverter PCB
  - operations 125
  - removing and replacing 211
- flatbed mode 116
- flatbed motor
  - operations 112
  - removing and replacing 200
- flatbed optical unit
  - diagrams and part numbers 337
  - operations 110, 126, 127
  - removing and replacing 188
- flatbed power supply, removing and replacing 202, 219
- flatbed scanner assembly, diagrams and part numbers 332
- flatbed scanning lamp
  - exposure operations 125
  - removing and replacing 191
- flatbed scanning operations
  - document exposure control 125
  - document size detection 128
  - overview 139
- font DIMMs, part numbers 319
- fonts
  - Courier settings 46, 69
  - list, printing 61
  - lists, printing 42
  - PCL settings 47, 70
- foreign interface connector 26
- form lines settings 70
- form lines, settings 47
- formatter operations 114, 137
- frequent jams, troubleshooting 293
- FRUs (field replaceable units)
  - part numbers 327
  - product, service, and exchange numbers 317
  - removing and replacing 147
  - service approach 28
- FTP firmware updates
  - Macintosh 91
  - Windows 90
- fuse, overcurrent/overvoltage protection 123
- fuser kit, part numbers 322
- fuser modes 44, 48
- G**
- Gate Array (GA) operations 124
- gateway settings 67
- glass
  - cleaning 105
  - leading edge calibration 283
  - left side calibration 282
  - removing and replacing 170
  - scaling calibration 284
- glass strip on ADF, cleaning 101
- H**
- hard disk
  - file directory page 42, 61, 300
  - job retention limit, setting 50, 74
  - locating 26
  - part numbers 319, 323
- hardware ready bits (HRB) 137
- harnesses, wiring 147
- heavy paper
  - detection 64
  - fuser mode 48
  - print modes 72
  - tray calibration 281
- height, adjusting 287

- help
  - service and support 28
  - troubleshooting 243
- HP Customer Support (HPCS) 28
- HP Fast InfraRed Connect 26, 319
- HP Jetdirect card, locating 26
- HP Jetdirect configuration page 61, 297
- HP Jetdirect print servers
  - EIO menu 53
  - part numbers 319
- HP Jet-Link cabling, troubleshooting 295
- HP JetLink connector 27
- HP LaserJet 9000 Series Printer software CD-ROM 321
- HP LaserJet Utility 92
- HP PartnerCare 30
- HP service agreements 30
- HP Web Jetadmin, firmware updates 87, 93
- HP-authorized resellers and support 30
- HPCS (HP Customer Support) 28
- HP-S (flatbed home position signal) 126
- HRB (hardware ready bits) 137
- HTTPS settings 55
- humidity specifications 24

**I**

- I/O submenu 52, 77
- idle mode specifications 24
- image cleaning kit, part numbers 322
- image drums, part numbers 322
- image quality
  - sample defects 302
  - settings 48, 72
  - troubleshooting 301
- image size, setting default 45
- image transfer kit, part numbers 322
- indicator lights
  - ADF 135
  - control panel, HP LJ 9000mfp/9000lmfp 32
  - control panel, HP LJ 9500mfp 34
  - copy processor board, status 140, 142, 262
  - copy processor board, troubleshooting 261
- Information menu 61
- information pages
  - configuration 295
  - file directory 300
  - HP Jetdirect 297
  - printing 42, 295
  - supplies status 298
  - usage 299
- InfraRed Connect 26
- input trays. *See* trays
- installation requirements
  - environmental 24
  - HP LJ 9000mfp/9000Lmfp 18
  - HP LJ 9500mfp 20
  - troubleshooting 246
- interface connections 26
- intermediate PCB assembly, removing and replacing 217
- intermediate PCB, ADF
  - operations 131
  - removing and replacing 209
- intermediate PCB, flatbed operations 125
- inverter PCB, flatbed
  - operations 125
  - removing and replacing 211
- inverter, ADF
  - operations 131
  - removing and replacing 208

- IP address
  - Show Address setting 50, 74
  - SMTP servers 38
- IPX/SPX settings 54
- isolating problems 245

**J**

- jams
  - recovery settings 51, 76
  - troubleshooting 293
- Jetadmin, firmware updates 87, 93
- Jetdirect card, locating 26
- Jetdirect configuration page 61, 297
- Jetdirect print servers
  - EIO menu 53
  - part numbers 319
- Jet-Link cabling, troubleshooting 295
- JetLink connector 27
- job retention
  - job storage limit, setting 50
  - limit, setting 74
  - listing stored 42
  - Retrieve job menu 60
  - timeout settings 50, 74
- JPEG data output 137

**K**

- keys, control panel
  - HP LJ 9000mfp/9000Lmfp 32
  - HP LJ 9500mfp 34
- kits, maintenance
  - installation guides 321
  - part numbers 317, 322

**L**

- label, product identification 22
- labels, print modes 48, 72
- lamp, scanning
  - ADF document exposure operations 131
  - ADF, removing and replacing 184
  - diagrams and part numbers 110
  - drive control 124
  - flatbed exposure operations 125
  - flatbed, removing and replacing 191
  - power supply 122
- landscape orientation, setting as default 47, 70
- language, control panel 36, 52, 76
- languages, printer
  - selecting 75
  - setting default 51
  - verifying installation 295
- LaserJet 9000 Series Printer software CD-ROM 321
- LDAP, locating servers 38
- leading edge calibrations
  - ADF back 279
  - ADF front 278
  - glass 283
- LEDs
  - ADF 135
  - control panel, HP LJ 9000mfp/9000lmfp 32
  - control panel, HP LJ 9500mfp 34
  - copy processor board, status 140, 142, 262
  - copy processor board, troubleshooting 261
- left side calibrations
  - ADF back 277
  - ADF front 274
- letterhead, print modes 48, 72
- light print setting, toner density 49

- lights
  - ADF 135
  - control panel, HP LJ 9000mfp/9000lmp 32
  - control panel, HP LJ 9500mfp 34
  - copy processor board, status 140, 142, 262
  - copy processor board, troubleshooting 261
- line feed settings 47, 71
- line spacing settings 47, 70
- lock, carriage 81, 127
- long edge binding settings 46, 69
- low print cartridges 76
- low print cartridges, settings 51
- low-voltage power supply operations 122
- lower delivery rollers
  - diagrams 111
  - removing and replacing 231
- lower registration roller assembly
  - diagrams 111
  - removing and replacing 225
- LPR commands, firmware updates 93

## M

- Macintosh firmware updates 91
- Macintosh, Appletalk settings 55
- mailbox, part number 320
- main assembly
  - diagrams and part numbers 347
  - removing and replacing 172
- maintenance
  - agreements 30
  - interval 58, 85
  - viewing count 58, 85
- maintenance kits
  - installation guide 321
  - part numbers 317
- manual feed settings 46, 69
- manual sensor test 83
- manuals
  - ordering 316
  - part numbers 320, 324
- map, menu 42, 59
- margins, settings 48, 72
- media
  - A4 paper settings 69
  - custom 63
  - default image size, setting 45
  - default size 68
  - fuser modes 44, 48
  - heavy, tray calibration 281
  - jams 293
  - print modes 72
  - size detection operations, ADF 134
  - size detection operations, flatbed 128
  - small, mode for 49
  - troubleshooting 246
  - type settings, trays 63
- memory
  - configuration page information 296
  - part numbers 319
  - ROM operations 124
  - verifying installation 295
- menu map 41, 59, 61

- menus
  - Configure device 45, 64
  - Copying 65
  - Diagnostics 58, 82
  - EIO 53, 78
  - E-mail 67
  - Enhancement 66
  - I/O 52, 77
  - Information 61
  - map 41, 42
  - Originals 64
  - Paper handling 62
  - PCL 47, 70
  - Print quality 48, 72
  - Printing 45, 68
  - Resets 57, 81
  - Retrieve job 42, 60
  - Sending 66
  - Service 58, 85, 266
  - System setup 50, 74
  - using 59

- messages
  - alphabetical list 253
  - event log 82, 249
  - numerical list 255
  - settings 51, 76
  - types of 252
- metal, screws for 326
- misfeeds, ADF 103, 293
- model numbers 22
- modes
  - fuser 44, 48
  - print 72
  - Sleep 50
- motors
  - ADF feeding operations 132
  - control operations 124
  - delivery, removing and replacing 198
  - flatbed, removing and replacing 200
  - pickup, removing and replacing 196
  - power supply 122
- multifunction finisher
  - documentation 320
  - part number 320
- multiple feeds, ADF 103, 294

## N

- narrow media settings 49
- navigation, control panel menus 59
- NetWare 79
- networks
  - Jetdirect print servers, part numbers 319
  - protocol settings 79
  - speed settings 57
- noise-level specifications 24
- Novell NetWare 79
- number of copies, setting default 45, 68
- numerical lists
  - messages 255
  - part numbers 358

## O

- operating environment
  - acclimating to 246
  - specifications 24

- operations
    - ADF angle detection 130
    - ADF document exposure 131
    - ADF document size detection 134
    - ADF feed control 132
    - ADF feeder sensors 135
    - ADF skew detection 136
    - copy processor board (CPB) 114, 138
    - fans 112
    - flatbed document exposure 125
    - flatbed document size detection 128
    - flatbed optical unit 126
    - LEDs, copy processor board 140, 142, 262
    - motors 112
    - overcurrent/overvoltage protection 123
    - power supply 117, 122
    - print engine comparison 108
    - scan engine 137
    - scanner controller board (SCB) 124
    - Sleep mode 119, 120
  - optical unit, ADF
    - diagrams and part numbers 350
    - operations 110
  - optical unit, flatbed
    - diagrams and part numbers 337
    - operations 110, 126, 127
    - removing and replacing 188
  - optimize option 73
  - ordering parts and supplies 28, 316
  - orientation, page 47, 70
  - Originals submenu 64
  - output bins, setting default 45, 69
  - output quality
    - sample defects 302
    - settings 48, 72
    - troubleshooting 301
  - output types, scanned data 137
  - overcurrent protection operations 123, 248
  - overhead transparencies, print modes 48, 72
  - override A4/letter 46, 69
  - overvoltage protection operations 123, 248
- P**
- page counts
    - printing usage page 299
    - viewing 58, 85
  - page orientation, default 47, 70
  - pan head screws, sizes and use 326
  - paper
    - A4 settings 69
    - custom 63
    - default image size, setting 45
    - default size 68
    - fuser modes 44, 48
    - heavy media tray calibration 281
    - jams 293
    - print modes 72
    - size detection operations, ADF 134
    - size detection operations, flatbed 128
    - small, mode for 49
    - troubleshooting 246
    - type settings, trays 63
  - paper deck drive assembly, part numbers 320
  - Paper handling menu 62
  - paper path test 82
  - paper pickup assembly, part numbers 320, 342
  - parallel connection speed, settings 77
  - parallel connector 26
  - part numbers
    - comparison 108, 109
    - list, alphabetical 353, 358
    - list, numerical 358
    - supplies, accessories, FRUs, and documentation 316
    - voltage 316
  - PartnerCare 30
  - parts
    - ordering 28, 316
    - removing and replacing 147
  - pay-per-page billing 299
  - PCB assemblies
    - ADF analog-processor, removing and replacing 207
    - ADF intermediate, removing and replacing 209
    - ADF inverter, removing and replacing 208
    - diagrams and part numbers 352
    - flatbed inverter, removing and replacing 211
    - intermediate, removing and replacing 217
    - operations 125, 131
  - PCBA, screws for 326
  - PCL font list, printing 42, 61
  - PCL submenu 47, 70
  - PCL-XL data 137
  - PDF error pages 46, 69
  - personalities
    - selecting 75
    - setting default 51
    - verifying installation 295
  - phone numbers
    - ordering parts 28
    - support 30
  - physical specifications
    - HP LJ 9000mfp/9000Lmfp 18
    - HP LJ 9500mfp 20
  - PI-1 sensor (ADF angle detection) 130
  - pickup home position detection sensor (PICK-S) 133
  - pickup motor
    - operations 112, 132
    - removing and replacing 196
  - pickup roller
    - ADF operations 133
    - assembly, removing and replacing 223
    - diagrams 111
    - removing and replacing 222
  - PIN, Service menu 58, 85
  - plastic, screws for 326
  - pliers required for service 147
  - portrait orientation, setting as default 47, 70
  - ports 26
  - PostScript error pages 46
  - PostScript font list, printing 42
  - power
    - consumption 23, 117
    - overcurrent/overvoltage protection 123
    - troubleshooting 247, 248
  - power cord
    - connector, locating 27
    - part numbers 324
  - power supplies
    - part numbers 317
  - power supply
    - fan 112
    - flatbed, removing and replacing 202, 219
    - operations 117, 122
    - troubleshooting 248

- PowerSave
  - energy consumption 23, 117
  - fan operation during 247
  - mode 119
  - noise-level specifications 24
  - settings 50
- preliminary operating checks, troubleshooting 246
- preprinted paper, fuser mode 48
- prepunched paper, fuser mode 48
- print cartridges
  - EconoMode 49
  - low 51, 76
  - out, settings 51
  - part numbers 317, 322
  - sample pages, printing 61
  - status page 298
- print engine, comparison between printer and MFP 108
- print modes 72
- print quality
  - sample defects 302
  - settings 48, 72
  - troubleshooting 301
- Print quality submenu 48, 72
- print servers
  - EIO menu 53
- print servers, part numbers 319
- print/stop test 83
- printer drivers, Web sites 29
- printer maintenance kits
  - installation guide 321
  - part numbers 317
- printing
  - event log 58
  - menu map 41
- printing information pages 295
- Printing submenu 45, 68
- priorities, messages 252
- private jobs 50
- production code 22
- programs, changing settings from 36
- proof and hold jobs 50
- protocols, network 53
- PS error pages 46, 69
- PS fonts, printing list 42, 61

## Q

- quality
  - sample defects 302
  - settings 48, 72
  - troubleshooting 301
- QuickCopy jobs 50

## R

- RAM disk settings 52
- recovery setting for jams 76
- recovery, jam 51
- registration
  - scanner 124
  - settings 72
  - tray settings 36, 48
- registration rollers
  - diagrams 111
  - lower, removing and replacing 225
  - operations 133
- registration sensor (REG-S) 135
- regulatory information 28
- remanufactured assemblies 28

- remote firmware updates
  - downloading 87
  - Macintosh 91
  - messages received during 94
  - troubleshooting 95
  - UNIX 89
  - Windows, FTP 90
  - Windows, LPR commands 93
  - Windows, network 89
- removing parts 147
- repair process 28
- replacing parts 147
- resellers, authorized 30
- Reset IC operations 124
- Resets submenu 57, 81
- resetting supplies 81
- resolution
  - digital sending 67
  - settings 48
- Resolution Enhancement technology (REt) 48
- restoring factory default settings 57, 81
- REt (Resolution Enhancement technology) 48
- Retrieve job menu on control panel 42, 60
- revision level 22
- RGB sample pages 61
- RJ11 connector, locating 27
- rollers
  - ADF feed control operations 133
  - cleaning 103
  - diagrams 111
  - feed assembly, removing and replacing 224
  - lower delivery, removing and replacing 231
  - lower registration, removing and replacing 225
  - motor operations 112
  - pickup assembly, removing and replacing 223
  - pickup, removing and replacing 222
  - upper delivery, removing and replacing 232
- ROM operations 124

## S

- scaling calibrations
  - glass 284
  - heavy media, ADF 281
  - plain media, ADF 280
- scan count 85
- scan engine
  - data processing operations 137
  - power supply operations 122
  - removing and replacing 238
- scan modes 116
- scanner
  - components 115
  - failure 255
  - settings 58, 85
- scanner controller board (SCB)
  - ADF feed control operations 132
  - calibrating 309
  - component operations 124
  - copy processor board signals 138
  - document detection operations 129
  - operations 114
  - power supply 122
  - removing and replacing 214
- scanner glass
  - cleaning 105
  - leading edge calibration 283
  - left side calibration 282
  - removing and replacing 170
  - scaling calibration 284

- scanner tests 84
- scanning lamp
  - ADF document exposure operations 131
  - ADF, removing and replacing 184
  - diagrams and part numbers 110
  - drive control 124
  - flatbed exposure operations 125
  - flatbed, removing and replacing 191
  - power supply 122
- screwdrivers required for service 147
- screws, types, sizes, and use 326
- security
  - configuration page 296
  - settings 57
  - Web sites, settings 55
- self-tapping screws, sizes and use 326
- Sending submenu 66
- sensors
  - ADF angle detection (PI-1) 130
  - ADF feeder 135
  - flatbed document size detection 128
  - pickup home position detection (PICK-S) 133
  - registration document detection (REG-S) 133
  - skew detection, ADF 136
  - testing 83
  - timing detection (TMG-S) 133
  - types of 311
- separation belts
  - ADF operations 133
  - assembly, removing and replacing 233
  - diagrams 111
  - removing and replacing 236
- serial number
  - locating on product 22
  - viewing with Service menu 58, 85
- servers, e-mail 38
- service agreements 30
- service approach 28
- Service menu 58, 85, 266
- service tests 265
- Set Registration 48
- settings
  - image quality 48
  - restoring defaults 57, 81
  - types of 36
- setup requirements
  - environmental 24
  - HP LJ 9000mfp/9000Lmfp 18
  - HP LJ 9040mfp/9050mfp 18
  - HP LJ 9500mfp 20
  - troubleshooting 246
- shading filter, removing and replacing 187
- shipping box size
  - HP LJ 9000mfp/9000Lmfp 18
  - HP LJ 9500mfp 20
- short edge binding settings 46, 69
- shutter solenoid
  - operations 132
  - removing and replacing 195
- signals
  - copy processor board 139
  - flatbed home position (HP-S) 126
- simplex mode 116
- simplified calibration 271
- size specifications
  - HP LJ 9000mfp/9000Lmfp 18
  - HP LJ 9040mfp/9050Lmfp 18
  - HP LJ 9500mfp 20
- sizes, paper
  - default 68
  - detection operations, ADF 134
  - detection operations, flatbed 128
- skew, ADF
  - adjusting 289
  - correction operations 133
  - detection operations 135, 136
  - troubleshooting 294
- Sleep mode
  - operations 119, 120
  - settings 50, 75, 81
- small paper mode 49
- SMTP servers 38
- software
  - HP LaserJet 9000 Series Printer CD-ROM 321
  - settings 36
  - Web sites 29
- solenoids
  - operations 124
  - power supply 122
  - shutter, removing and replacing 195
  - weight, removing and replacing 194
- sound specifications 24
- space requirements
  - HP LJ 9000mfp/9000Lmfp 18
  - HP LJ 9040mfp/9050mfp 18
  - HP LJ 9500mfp 20
- specifications
  - electrical 23
  - environmental 24
  - noise-level 24
  - space requirements, HP LJ 9000mfp/9000Lmfp 18
  - space requirements, HP LJ 9040mfp/9050mfp 18
  - space requirements, HP LJ 9500mfp 20
- speed
  - data transmission settings 52
  - network settings 57
  - resolution settings 48
- stacker Install guide 320
- standby power consumption 117
- staple cartridges, part numbers 317
- stapler/stacker Install guide 320
- Start guide 320
- static precautions 147
- status
  - messages 252
  - supplies 42, 61, 298
- status lights
  - ADF 135
  - control panel, HP LJ 9000mfp/9000Lmfp 32
  - control panel, HP LJ 9500mfp 34
  - copy processor board, states 140, 142, 262
  - copy processor board, troubleshooting 261
- status messages 51
- stop test 83
- storage capabilities, verifying 300
- stored jobs 50
  - limit, setting 74
  - listing current 42, 60
- subassemblies
  - diagrams and part numbers 316
  - removing and replacing 147
  - service approach 28
- supplies
  - ordering 28, 316
  - part numbers 317, 322
  - resetting 81

- supplies status page
  - printing 42, 61
  - using 298
- support
  - HP PartnerCare 30
  - phone numbers 28
  - websites 29
- switches, removing ADF feeder cover detection 193
- symbol sets 47, 71
- System setup submenu 50, 74

## T

- tapping screws, sizes and use 326
- TCP/IP settings 53, 78
- telephone numbers
  - ordering parts 28
  - support 30
- temperature specifications 24
- temporary settings 36
- tests
  - Diagnostics menu 58, 82
  - service 58, 265
  - troubleshooting, preliminary 246
- time, setting
  - fax 39
  - MFP 50, 74
- timeout settings
  - copy 75
  - held jobs 50
  - I/O 52, 77
  - job retention 74
  - Sleep mode 50
- timing detection sensor (TMG-S) 133, 135
- toner
  - coverage, usage page information 299
  - density settings 49
- tools required for service 147
- torque values for screws 326
- touch-screen graphical display
  - calibration 268
  - HP LJ 9000mfp/9000Imfp 33
  - HP LJ 9500mfp 35
- transparencies, print modes 48, 72
- transport defects 287
- tray 1
  - Install guide 320
  - part number 319
- tray 4
  - Install guide 320
  - part number 319, 320
  - settings 43

- trays
  - configuration page information 296
  - face-up 108
  - glass scaling calibration 284
  - heavy scaling calibration 281
  - jams, troubleshooting 293
  - leading edge back calibration, ADF 279
  - leading edge calibration, glass 283
  - leading edge front calibration, ADF 278
  - left side back calibration, ADF 277
  - left side calibration, glass 282
  - left side front calibration, ADF 274
  - media type settings 63
  - modes 74
  - part numbers 320
  - plain scaling calibration 280
  - registration 36, 48
  - selecting 50
  - settings 43
  - size settings 62
- troubleshooting
  - ADF height 287
  - ADF misfeeds 103
  - basic procedures 245
  - control panel messages 249, 252
  - copy processor board 260
  - diagnostics 264
  - Diagnostics menu 82
  - environment 246
  - event log 249
  - firmware updates 95
  - image quality 301
  - information pages 295
  - jams 293
  - media 246
  - power 247
  - preliminary operating checks 246
  - skew 289
  - weight solenoid 292
- two-sided printing 46
- type settings, trays 63
- types, paper
  - fuser modes 48
  - tray settings 43

## U

- UNIX
  - carriage return settings 47
  - firmware updates 89
- updating firmware
  - downloading 87
  - Macintosh 91
  - messages received during 94
  - troubleshooting 95
  - UNIX 89
  - Windows, FTP 90
  - Windows, local port 88
  - Windows, LPR commands 93
  - Windows, network 89
- upper delivery roller assembly
  - diagrams 111
  - removing and replacing 232
- upper registration roller assembly, diagrams 111
- usage page
  - printing 42, 61
  - using 299
- USB port, locating 27
- user guides, part numbers 320, 324

## V

- vertical line spacing settings 47, 70
- vertical transfer assembly, part numbers 320
- viewing
  - current MFP settings 295
  - directory structures 300
  - event log 58
  - page and maintenance counts 58, 85
- voltage
  - allowable variations 246
  - overvoltage protection 123
  - part numbers 316
  - power supply operations 122
  - specifications 23, 117

## W

- wake time, setting 50
- warning messages 252
- warranty information 28
- washers, sizes and use 326
- Web Jetadmin, firmware updates 87, 93
- Web sites
  - documentation 320
  - firmware 87
  - HP Partner Care 30
  - security settings 55
  - support 29
- weight plate operations 132
- weight solenoid
  - adjusting 292
  - removing and replacing 194
- white board
  - cover, removing and replacing 157
  - image quality, troubleshooting 304
- Wide A4 setting 46, 69
- width detection sensor, ADF
  - adjusting 291
  - operations 134
  - removing and replacing 210
- Windows
  - FTP firmware updates 90
  - local port firmware updates 88
  - LPR command firmware updates 93
  - network firmware updates 89
- wiring
  - defective 248
  - diagrams 312
  - replacing harnesses 147







i n v e n t

© 2004 Hewlett-Packard Development Company, L.P.

<http://www.hp.com>



C8549-90955