

Geologic Structures

Chapter 6

Geologic Structures

Copyright © The McGraw-Hill Companies, Inc. Permission required for reproduction or display.



C. C. Plummer

Geologic Structures

- How rocks respond to tectonic forces caused by movement of lithospheric plates
- *Structural Geology*:
 - How rocks that were once deposited in horizontal layers are now found bent (folded) and broken (faulted)

Geologic Structures

- *Geologic structures* are dynamically-produced patterns or arrangements of rock or sediment that result from, and give information about, forces within the Earth
 - Produced as rocks change shape and orientation in response to applied stress
 - *Structural geology* is the study of the shapes, arrangement, and interrelationships of rock units and the forces that cause them
 - Studying rock structure gives us important clues regarding **(1) precious ore mineral deposits; (2) oil and natural gas deposits; (3) future tectonic movement (earthquakes); (4) infrastructure development**

Tectonic Forces at Work

Stress and Strain in the Earth's Lithosphere

3 Types of Stress

Compressive stress

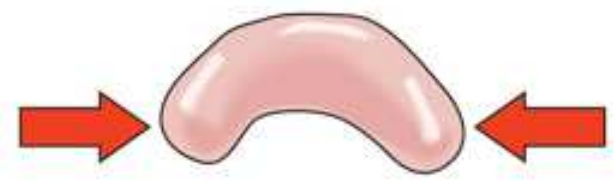

Shortened

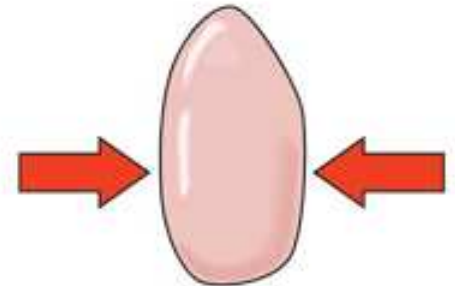

Flattened

A

What type of plate motion??

Tensional stress

Stretching or extension

A?

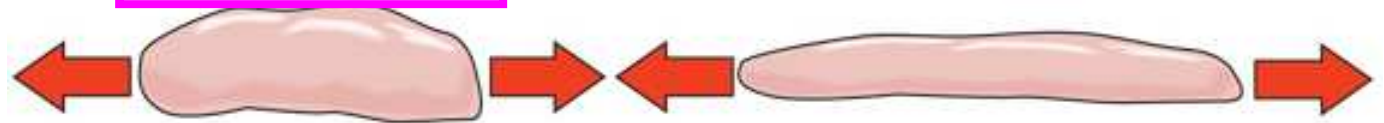

B?

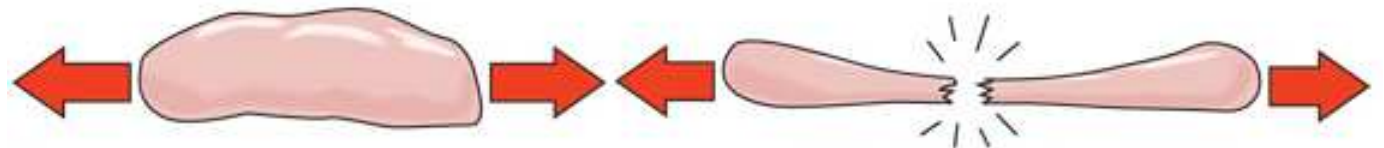

Stretching and breaking

B

3rd Type of Stress

Copyright © The McGraw-Hill Companies, Inc. Permission required for reproduction or display.
Card deck

Shear strain

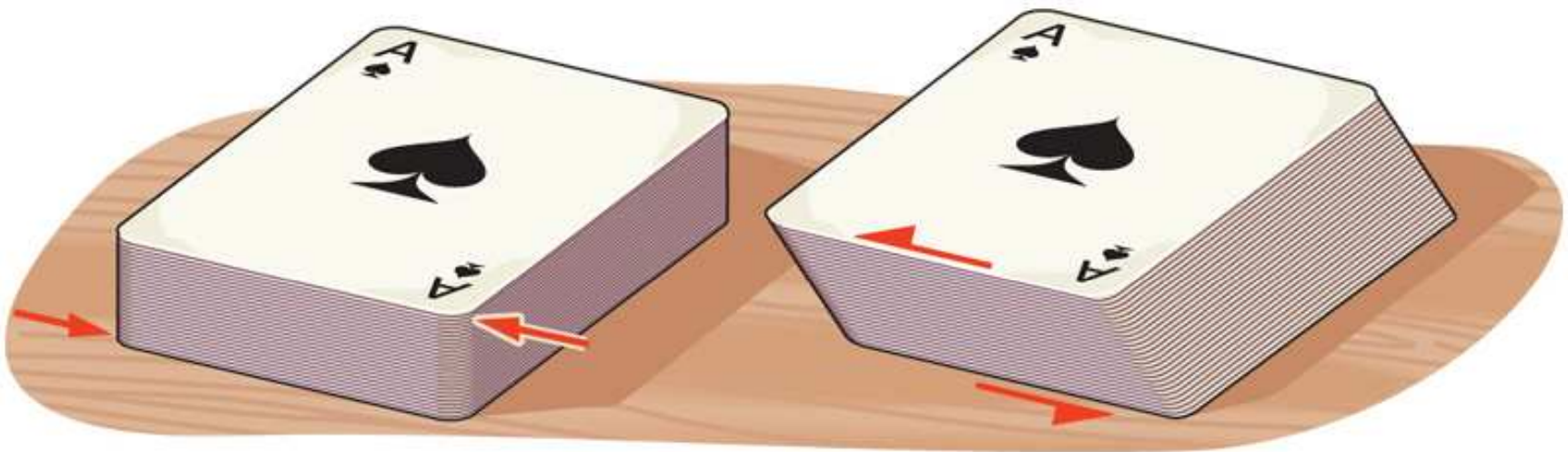

Shear Stress

Stress and Strain

- *Stress* is force per unit area
 - The three basic types of stress are *compressive*, *tensional* and *shear*
- *Strain* is a change in size or shape in response to stress
 - Geologic structures are indicative of the type of stress and its rate of application, as well the physical properties of the rocks or sediments

How Rocks Respond to Stress

- Rocks behave as *elastic*, *ductile/plastic*, or *brittle* materials depending on:
 - amount and rate of stress application
 - type of rock
 - temperature and pressure
- If deformed materials return to original shape after stress removal, they are behaving *elastically*
- However, once the stress exceeds the *elastic limit* of a rock, it deforms permanently
 - *ductile* deformation involves bending *plastically*
 - *brittle* deformation involves *fracturing*

Brittle vs. Ductile Deformation

Copyright © The McGraw-Hill Companies, Inc. Permission required for reproduction or display.

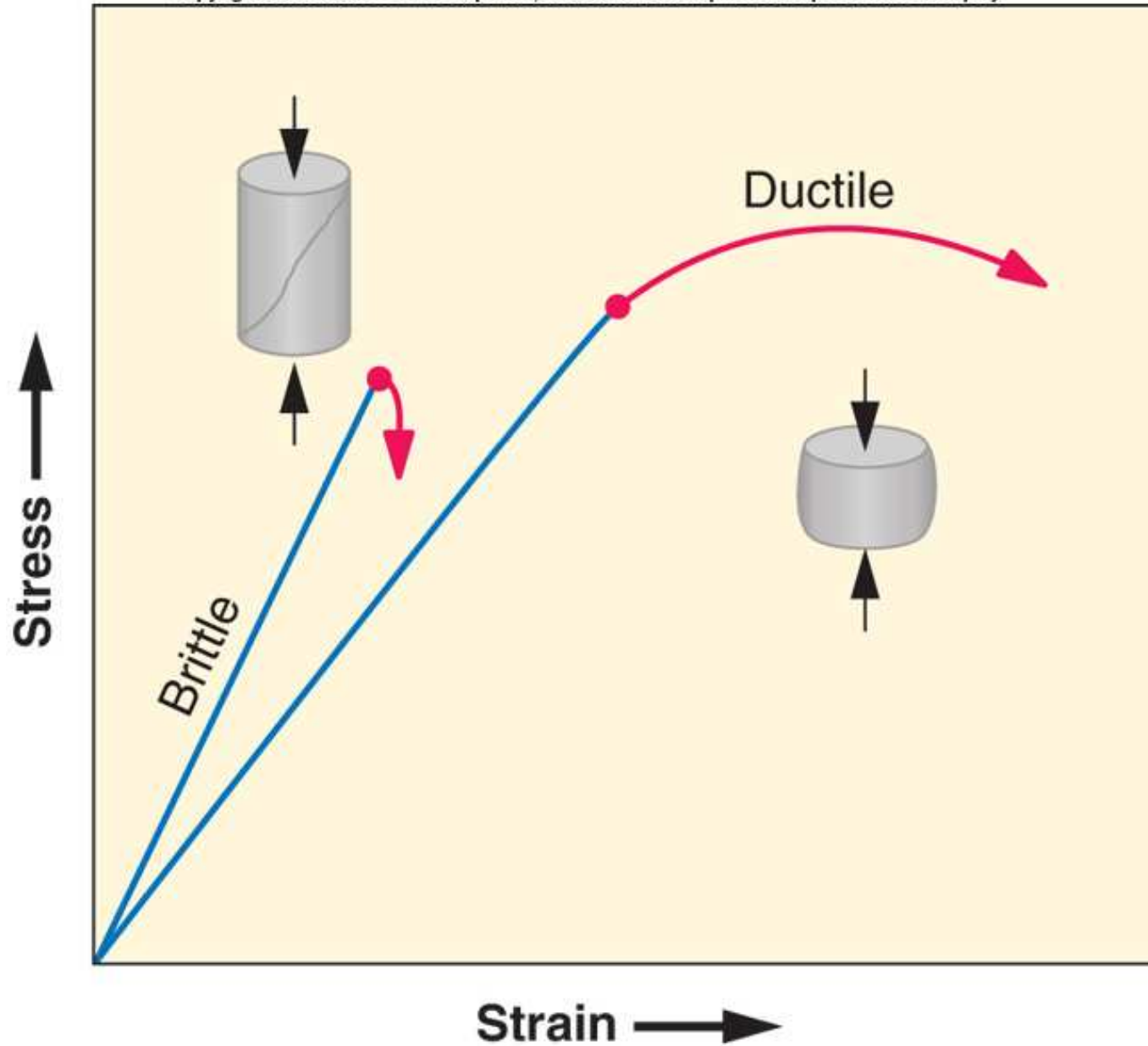

How does effect of stress manifest in rocks?

- **Elastic**

- Deformed material recovers initial shape

- **Ductile/Plastic**

- Does not return to initial shape; bends in response to stress

- **Brittle**

- Does not return to initial shape; fractures at points of weakness

Brittle vs. Ductile Deformation

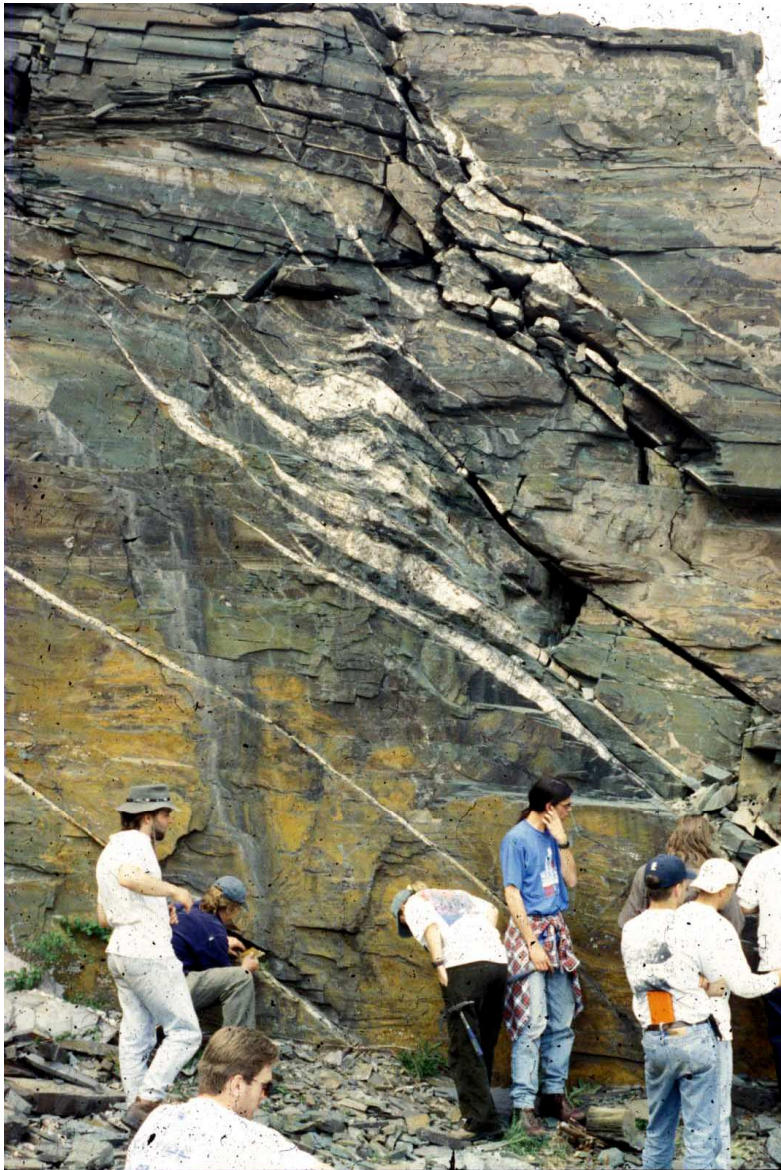

Structures and Geologic Maps

- Rock structures are determined on the ground by geologists observing rock *outcrops*
 - *Outcrops* are places where bedrock is exposed at the surface
- Geologic maps use standardized symbols and patterns to represent rock types and geologic structures, such as *tilted beds*, *joints*, *faults* and *folds*

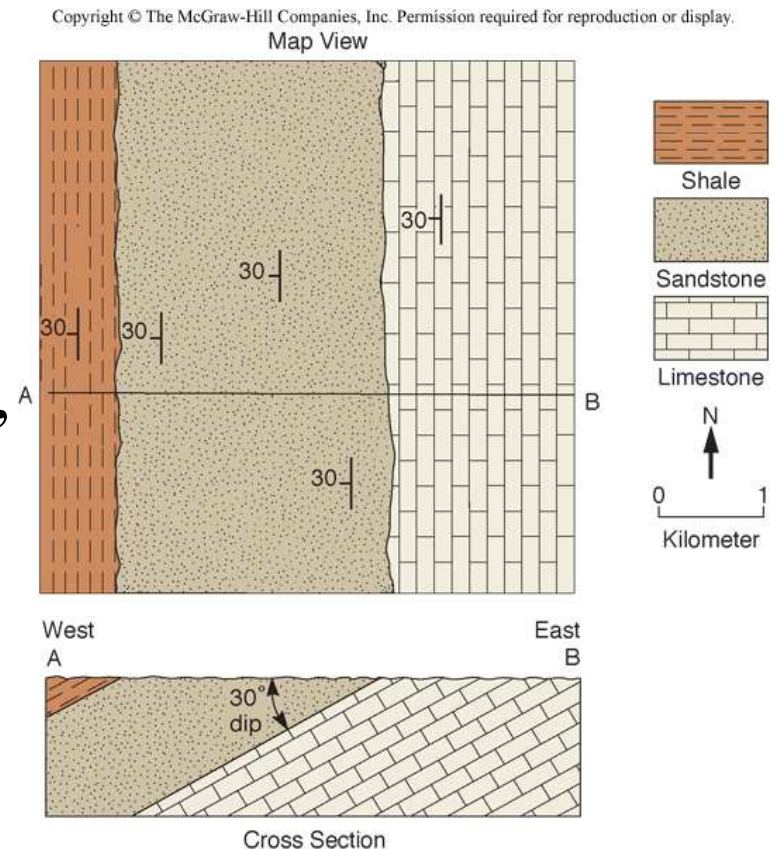

Map View vs. Cross Section





Diane Carlson



Photo by Diane Carlson

Copyright © The McGraw-Hill Companies, Inc. Permission required for reproduction or display.



Diane Carlson

Orientation of Geologic Structures

- Geologic structures are most obvious in deformed sedimentary rocks
- *Tilted beds*, *joints*, and *faults* are planar features whose orientation is described by their *strike* and *dip*



Orientation of Geologic Structures

- *Strike* is the compass direction of a line formed by the intersection of an inclined plane with a horizontal plane
- *Dip* is the direction and angle from horizontal in which a plane is oriented

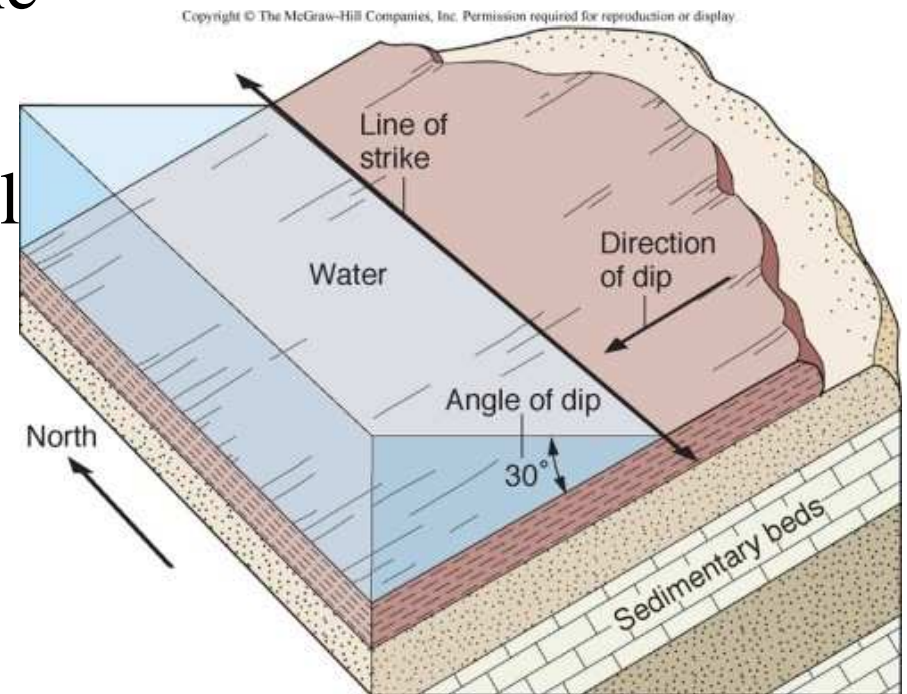

Dip and Strike

- Dip angle is always measured at a right angle to the strike
- Brunton Pocket Transit is used by geologists to measure strike and dip

Copyright © The McGraw-Hill Companies, Inc. Permission required for reproduction or display.
Map View

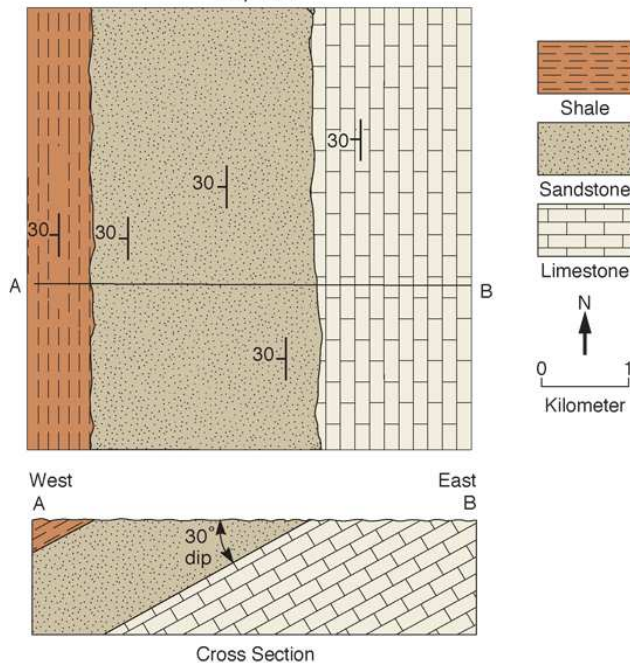

Types of Geologic Structures

- *Folds*
- *Joints/Fractures*
- *Faults*

FOLDS

- *Folds* are wavelike bends in layered rock
 - Represent rock strained in a *ductile* manner, usually under *compression*
- The *axial plane* divides a fold into its two *limbs*
 - The surface trace of an axial plane is called the *hinge line* (or *axis*) of the fold

- *Anticlines* are upward-arching folds, and

- *Synclines* are downward-arching folds

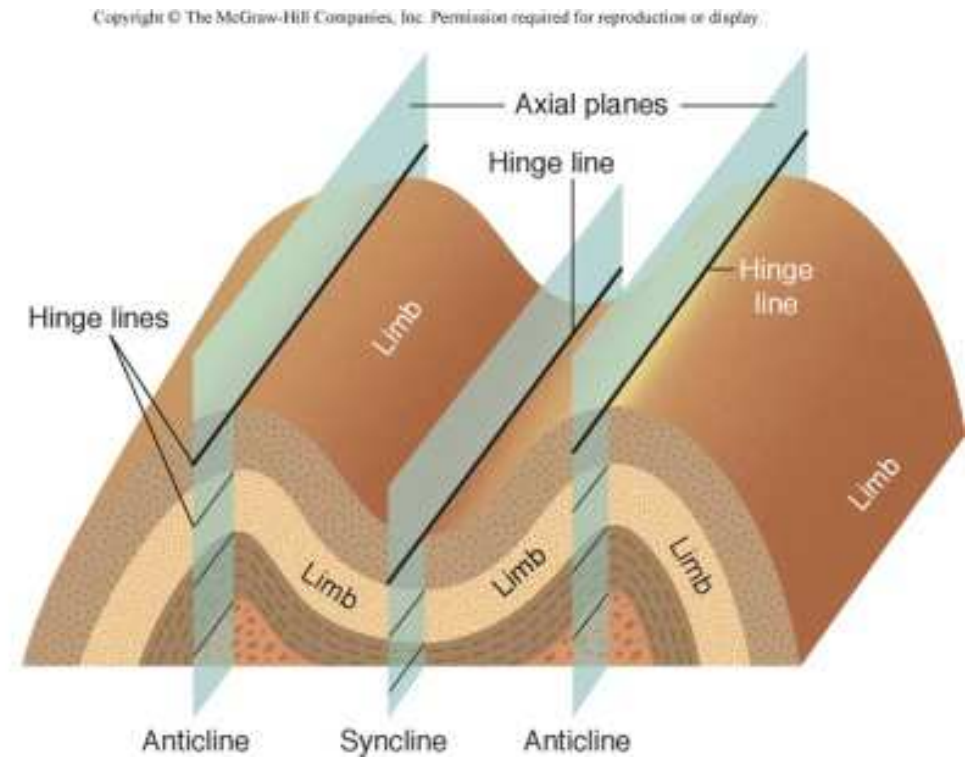

Fold Structure

Copyright © The McGraw-Hill Companies, Inc. Permission required for reproduction or display.

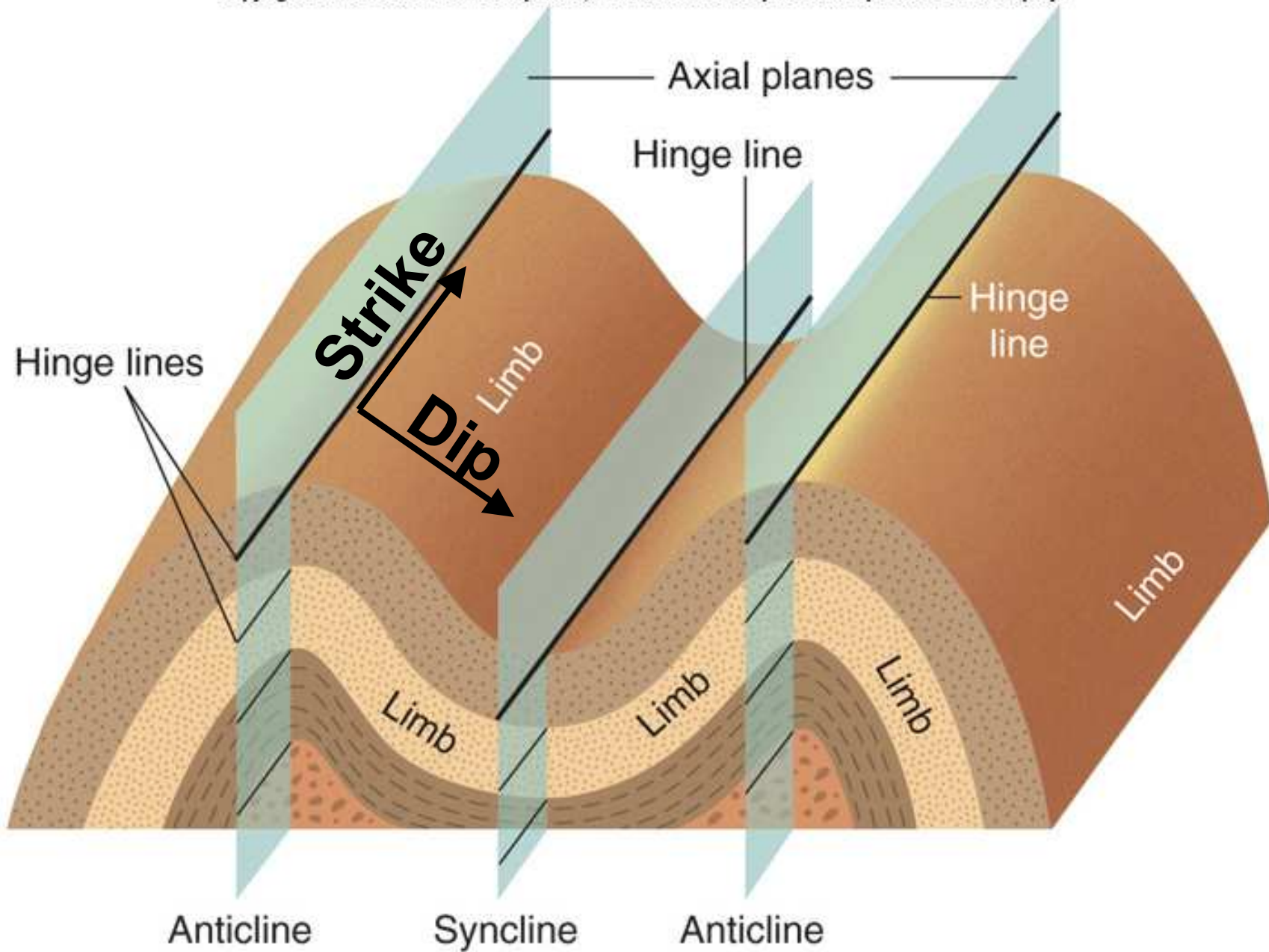

Copyright © The McGraw-Hill Companies, Inc. Permission required for reproduction or display.

Hinge line of syncline

Hinge line of anticline

Younger rock unit exposed at the surface

Older rock unit exposed at the surface

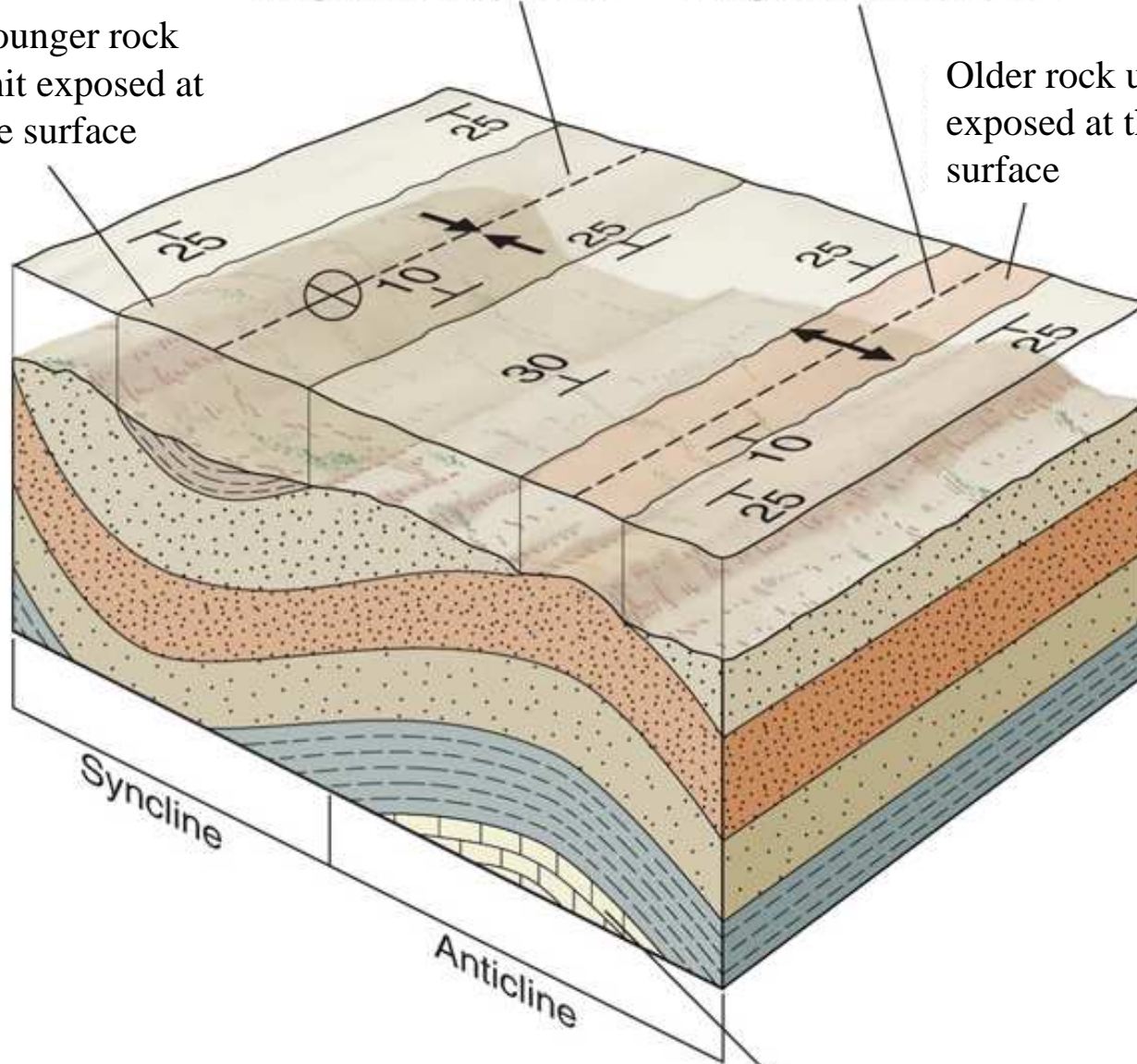

Syncline

Anticline

Oldest rock unit

Types of Folds

Anticlines



Synclines



Types of Folds

- *Plunging folds* are folds in which the hinge line (fold axis) is not horizontal
 - plunging folds form V- shaped patterns of exposed rock layers (beds)

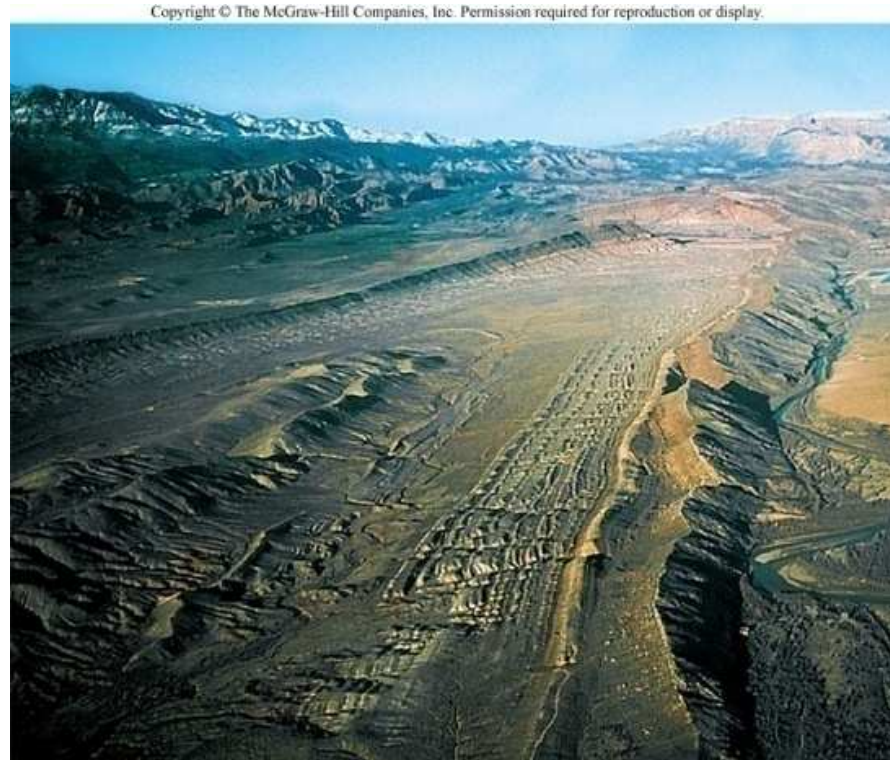

Plunging Folds

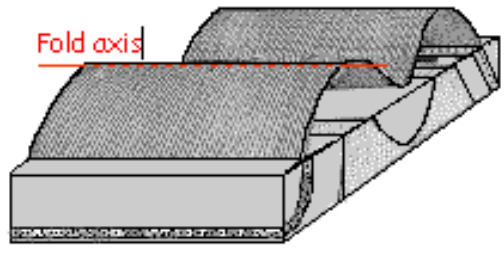

Non Plunging

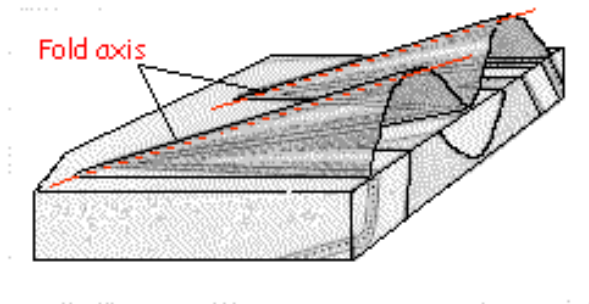

Plunging

Types of Folds

- *Open folds* have limbs that dip gently

Copyright © The McGraw-Hill Companies, Inc. Permission required for reproduction or display.

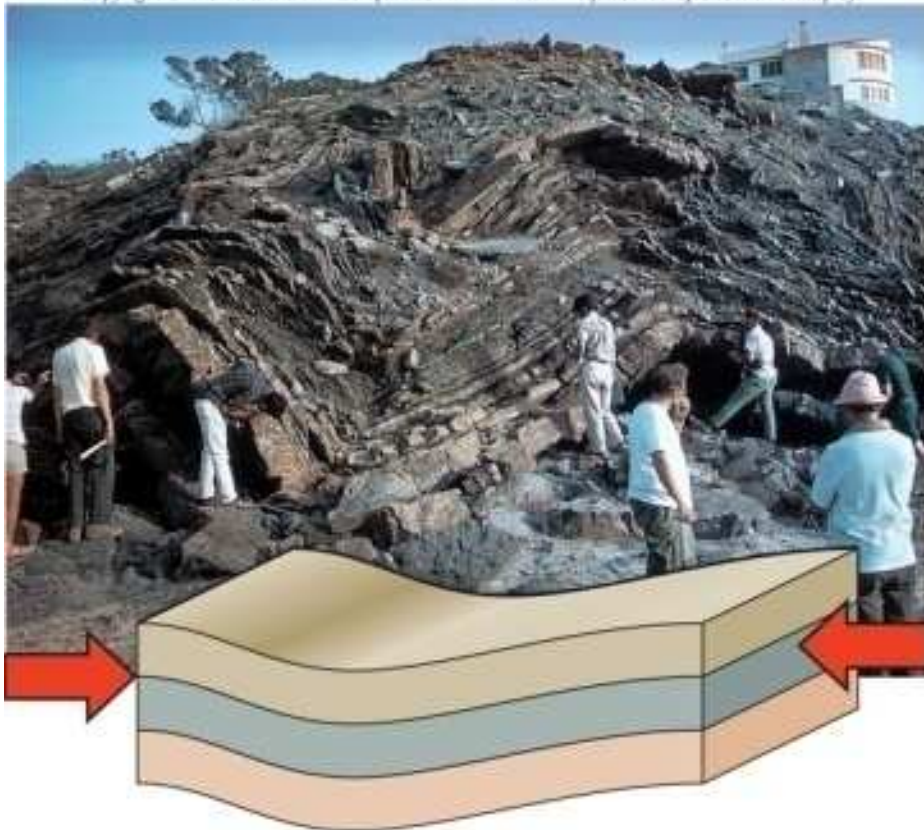

A Open folds

Photo by C. C. Plummer



Open Folds

Gently dipping limbs
Less modified by strain

Copyright © The McGraw-Hill Companies, Inc. Permission required for reproduction or display.

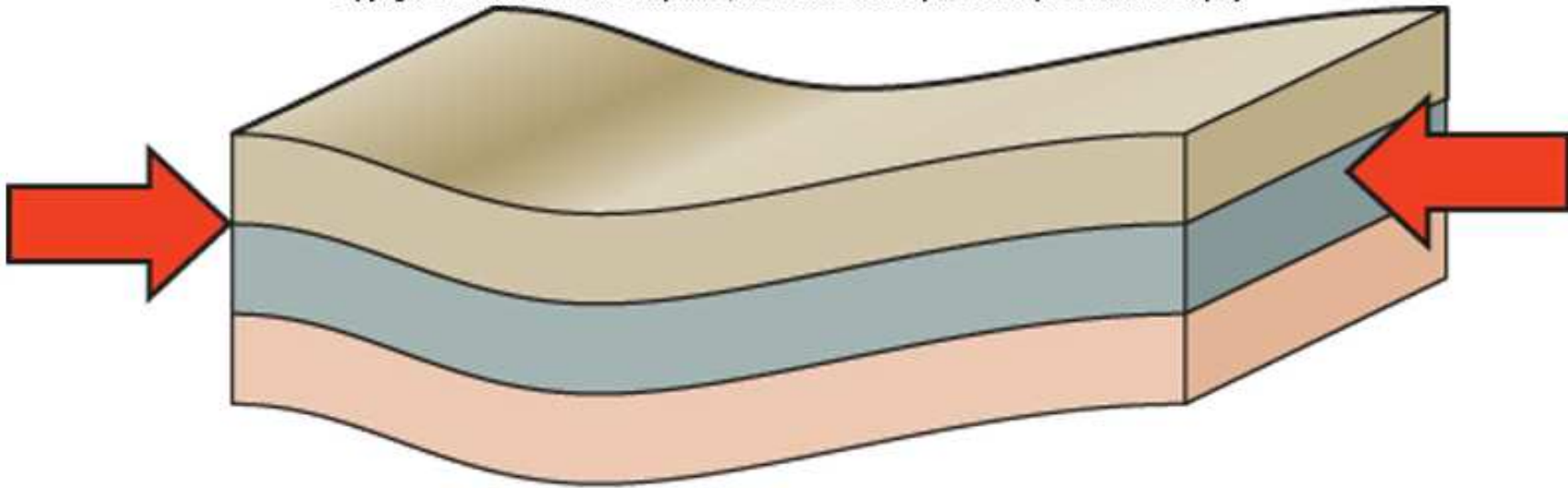

A Open folds

Types of Folds

- *Isoclinal folds* have parallel limbs:- When the two limbs of a fold are essentially parallel to each other and thus approximately parallel to the axial plane, the fold is called isoclinal.

Copyright © The McGraw-Hill Companies, Inc. Permission required for reproduction or display.



B Isoclinal ("hairpin") folds

Photos by Diane Carlson

Isoclinal Folds

Steeply dipping limbs

Highly modified by strain

Copyright © The McGraw-Hill Companies, Inc. Permission required for reproduction or display.

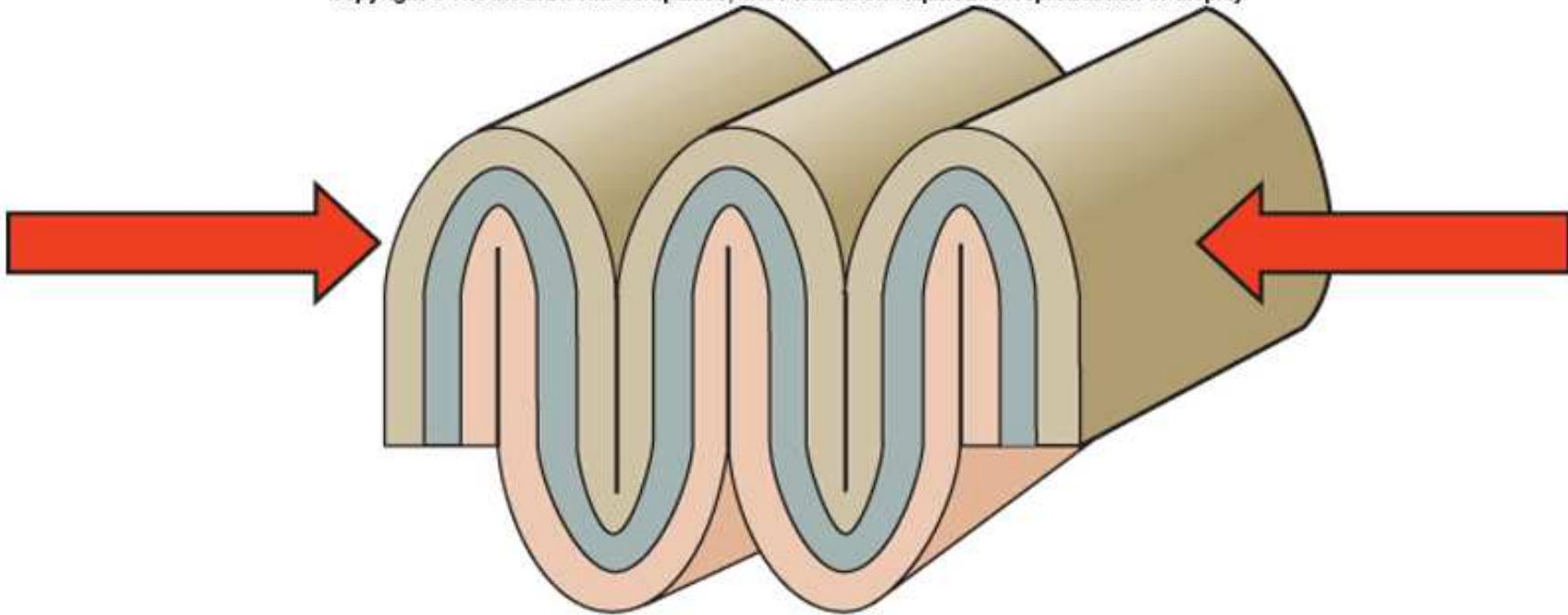

B Isoclinal (hairpin) folds

Types of Folds

- *Overtured folds* have limbs that dip in the same directions,

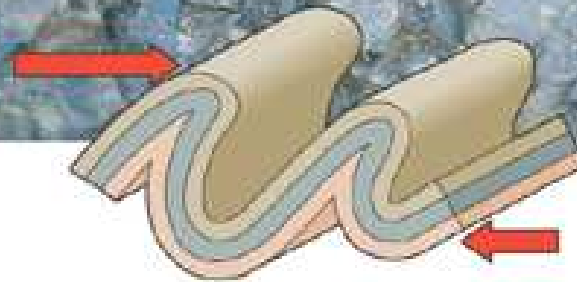
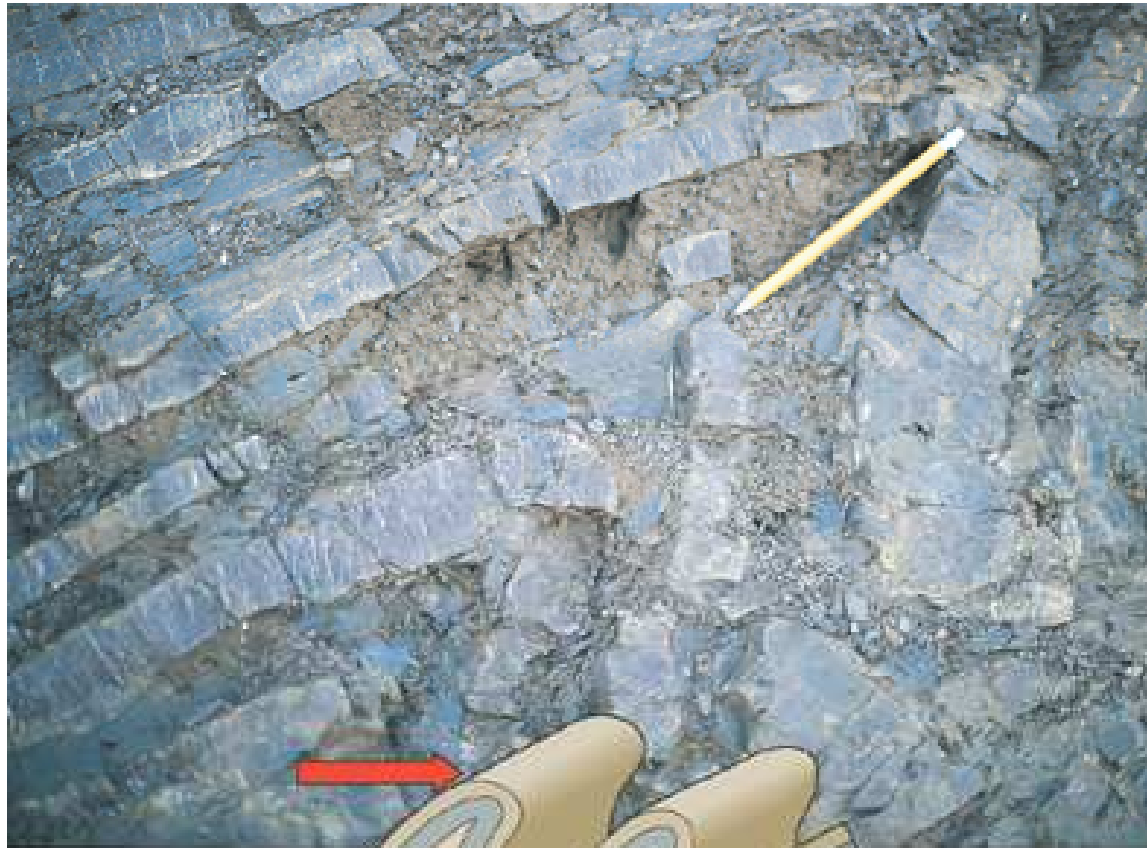

Overtured folds

Overturned Folds

**Center of fold is dipping such that
the limbs dip in the same direction**

Highly modified by strain

Copyright © The McGraw-Hill Companies, Inc. Permission required for reproduction or display.

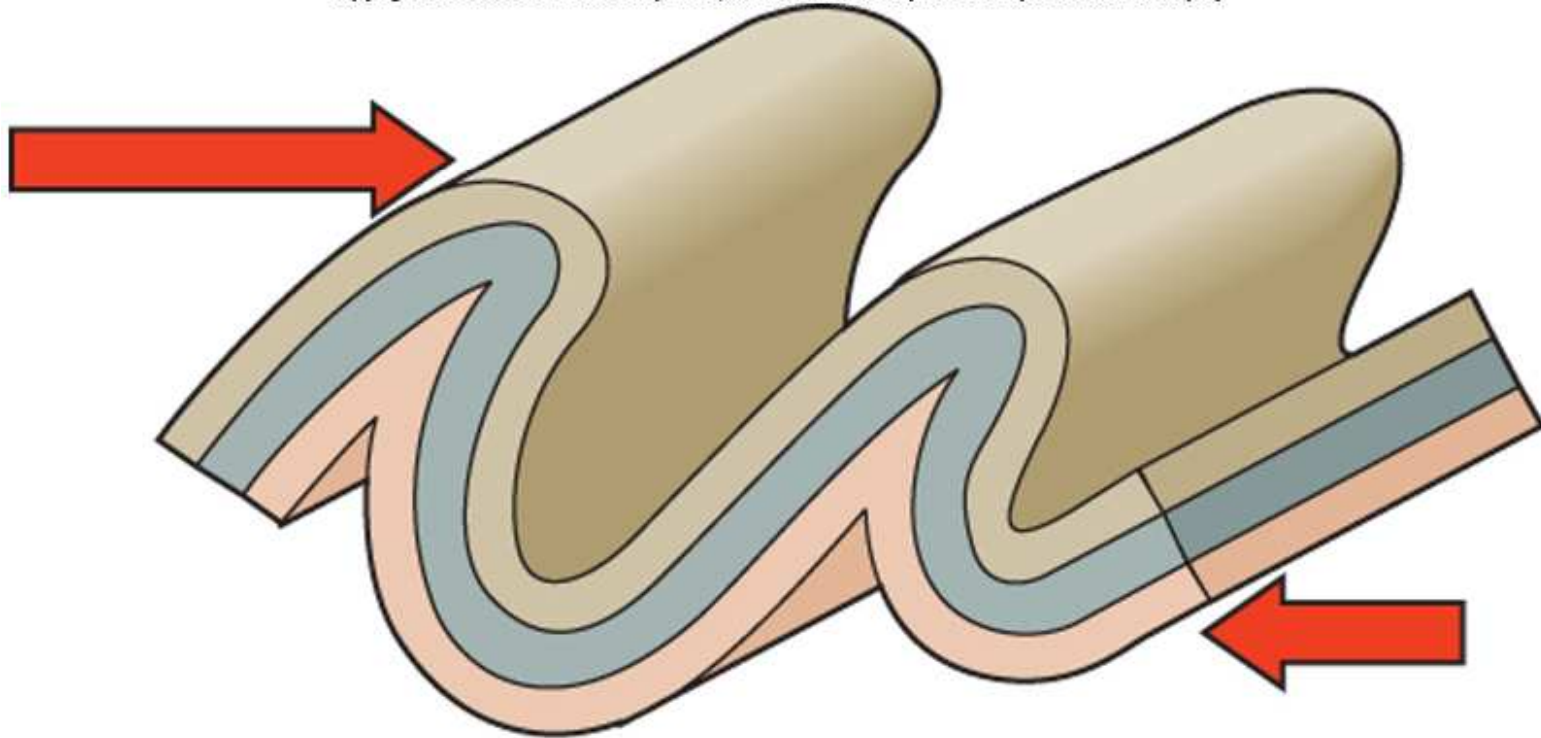

C Overturned folds

Types of Folds

- *Recumbent folds* are overturned to the point of being horizontal

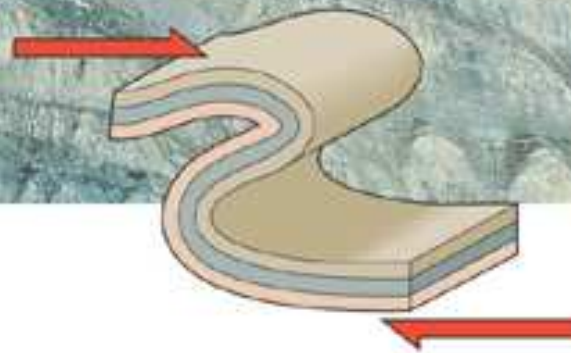
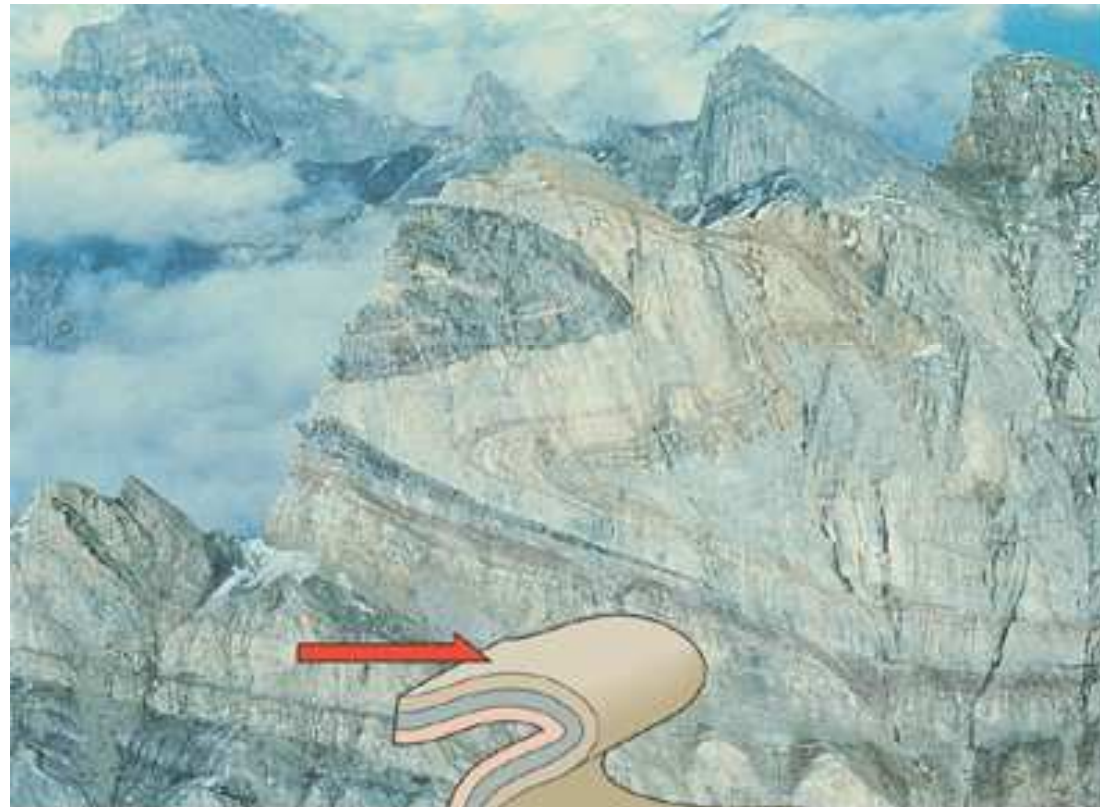

Recumbent folds

Recumbent Folds

Overtaken so much that the dip of the limbs is horizontal

Highly modified by strain

Copyright © The McGraw-Hill Companies, Inc. Permission required for reproduction or display.

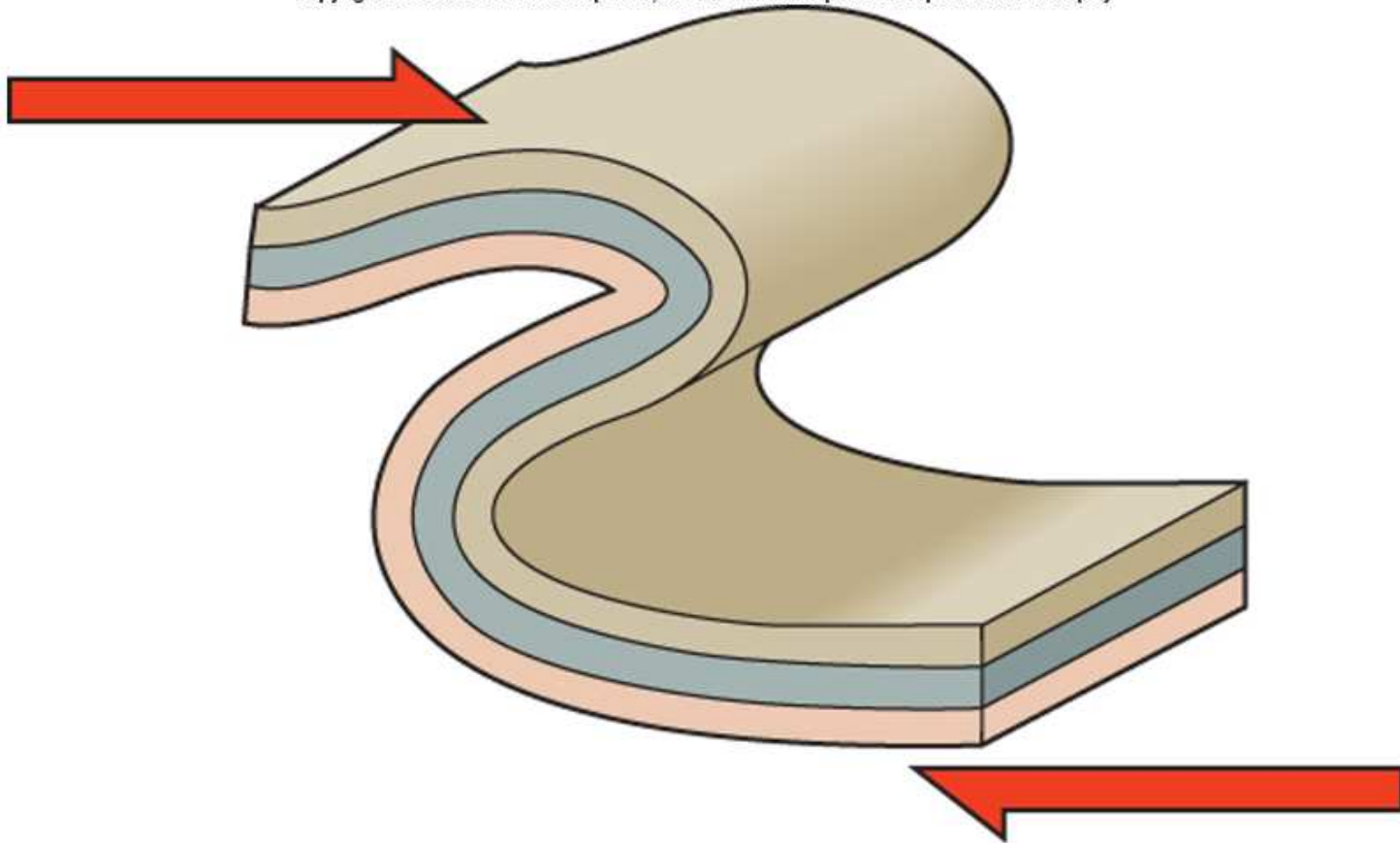

D Recumbent folds

Structural Domes and Basins

- *Domes* are structures in which the beds dip away from a central point

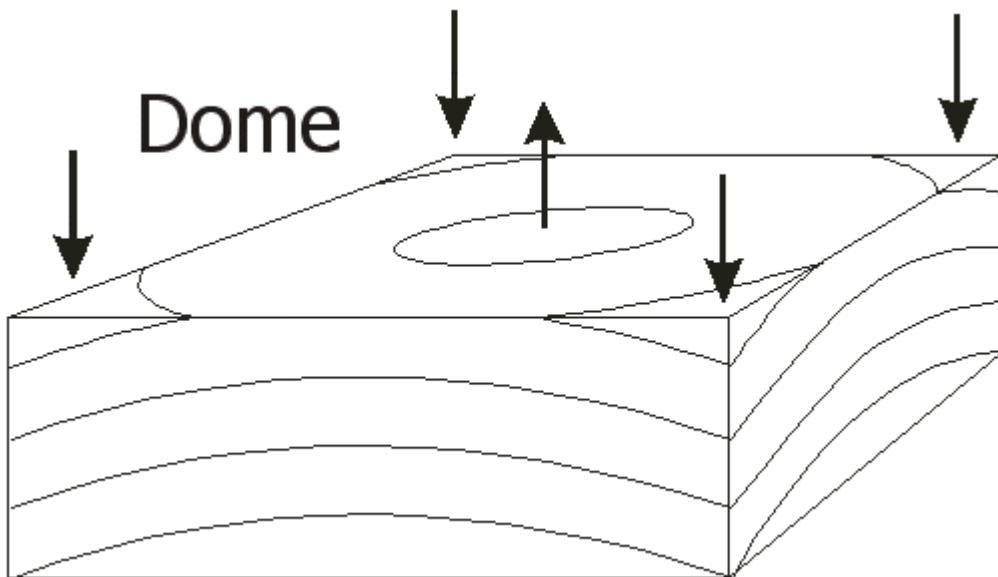

Green Mountain dome, near Sundance, WY

Structural Dome

Beds dip away from a central point

Resembles an anticline in cross section

Copyright © The McGraw-Hill Companies, Inc. Permission required for reproduction or display.

Oldest layer exposed at the surface

Youngest layer

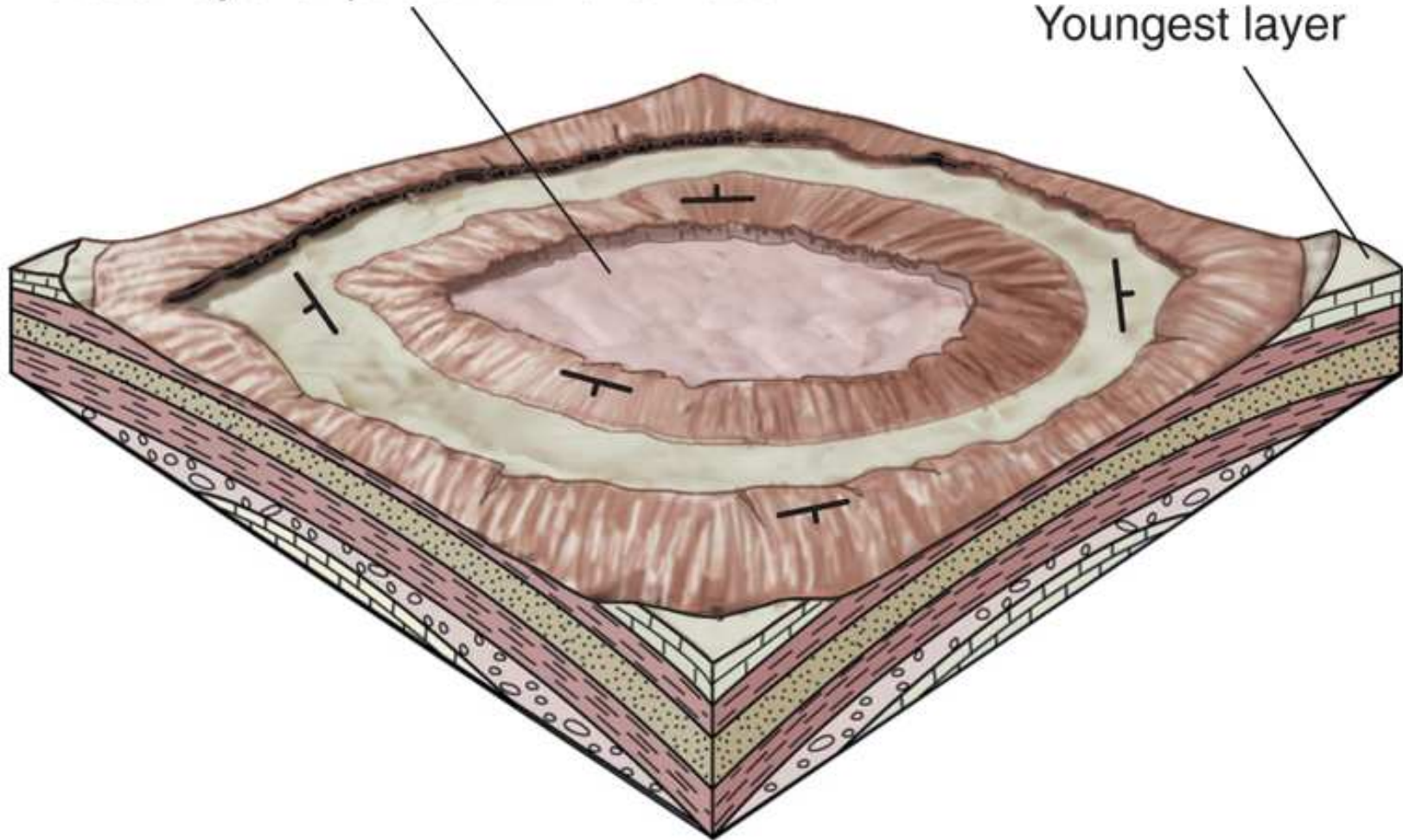

A

Structural Domes and Basins

- *Basins* are structures in which the beds dip toward a central point

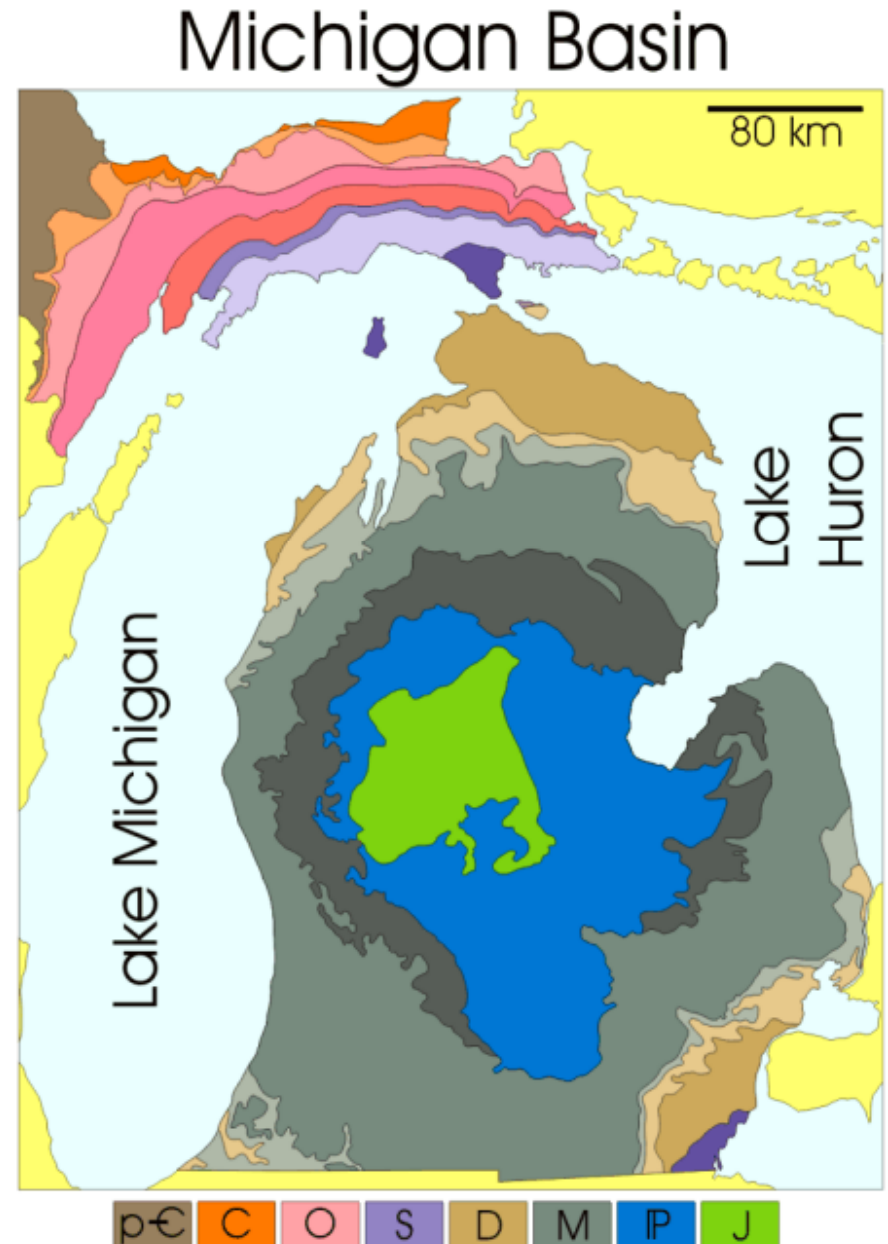
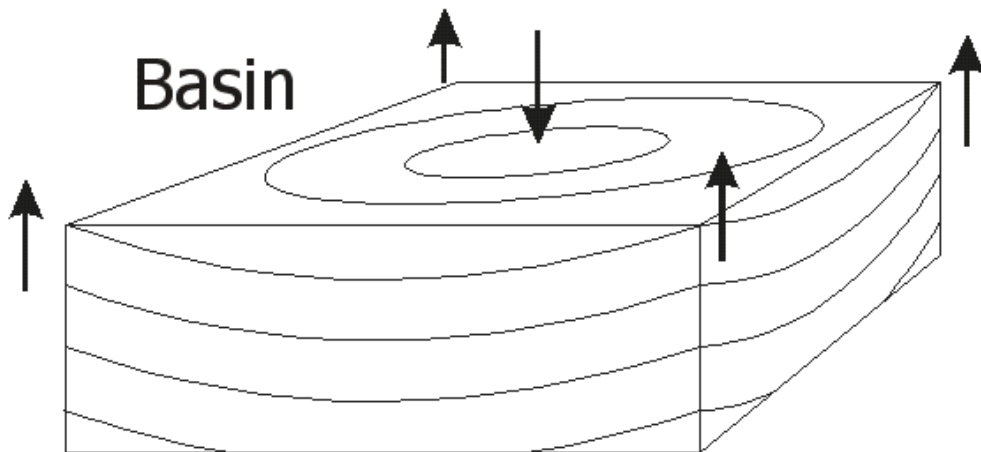

Structural Basin

Beds dip towards a central point

Resembles an syncline in cross section

Copyright © The McGraw-Hill Companies, Inc. Permission required for reproduction or display.

Youngest layer

Oldest layer exposed
at the surface

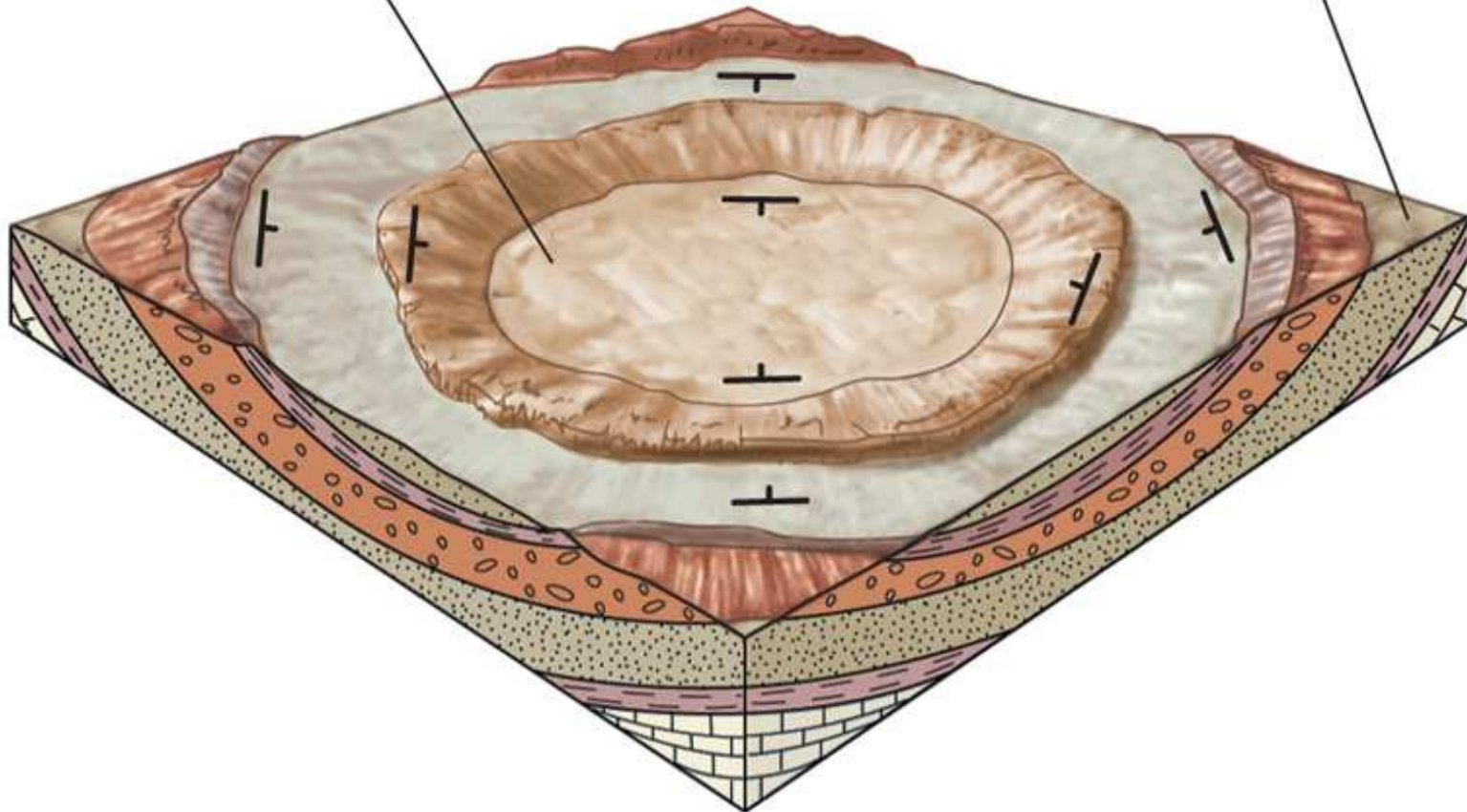

B

Fractures in Rock

Copyright © The McGraw-Hill Companies, Inc. Permission required for reproduction or display.

- *Joints* - fractures bedrock along which no movement has occurred
 - Multiple parallel joints are called *joint sets*



Frank M. Henna

Fractures in Rock

- *Faults* - fractures in bedrock along which movement has occurred
 - Considered “active” if movement has occurred along them within the last 11,000 years
 - Categorized by type of movement as *dip-slip*, *strike-slip*, or *oblique-slip*

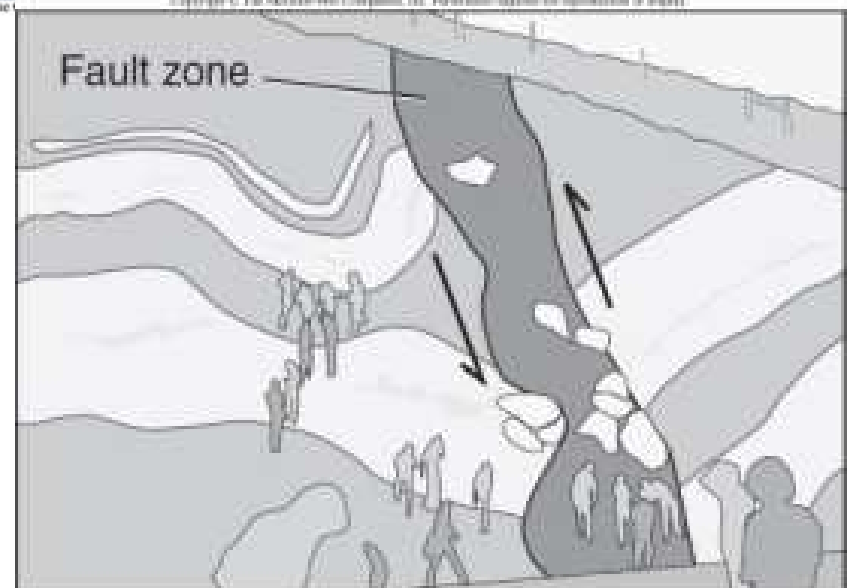
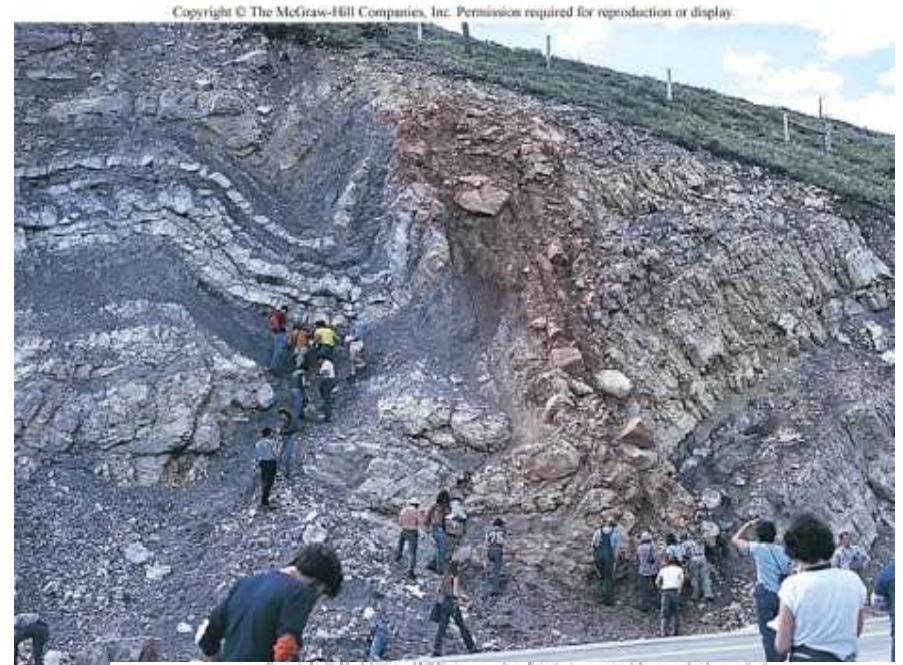

Dip-slip Faults

Movement is parallel to the dip of the fault surface

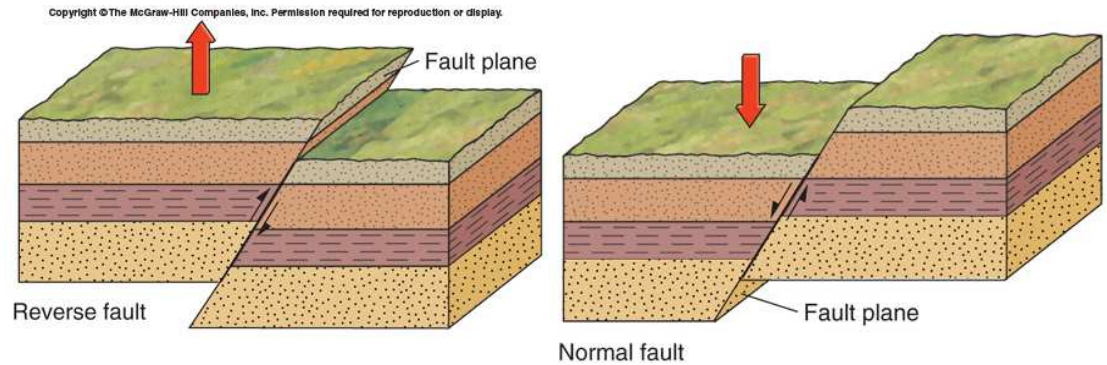

Strike-slip Faults

Movement is parallel to the strike of the fault surface

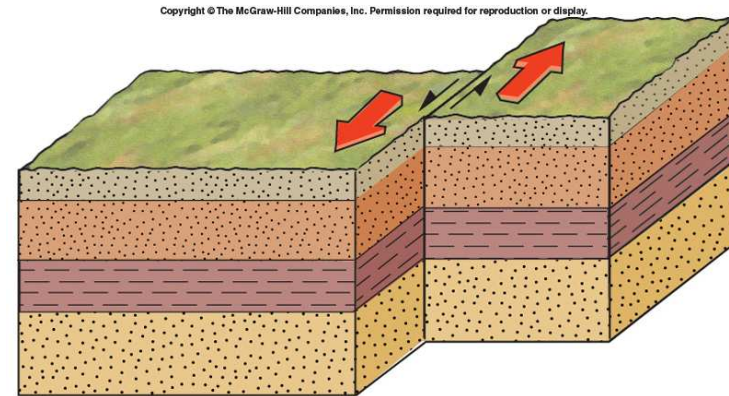

Oblique-slip Faults

Movement has both strike and dip components

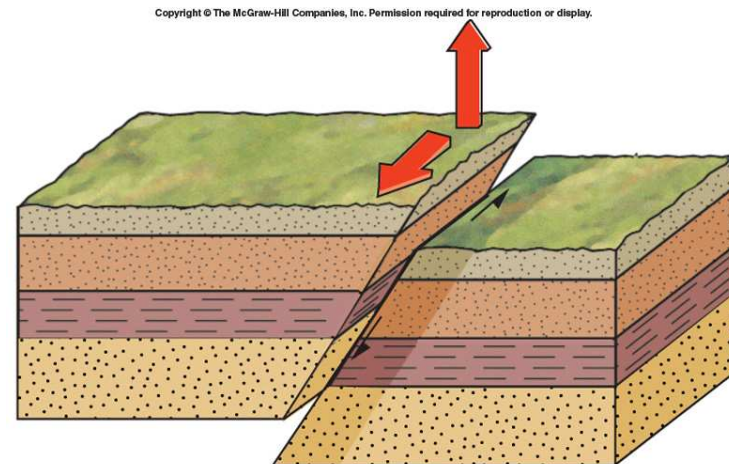

Types of Faults

- *Dip-slip faults* have movement parallel to the dip of the fault plane
 - In *normal faults*, the *hanging-wall block* has moved down relative to the *footwall block*
 - In *reverse faults*, the hanging-wall block has moved up relative to the footwall block
 - In *thrust faults* (a type of reverse fault), the dip of the fault plane is at low angle or even horizontal

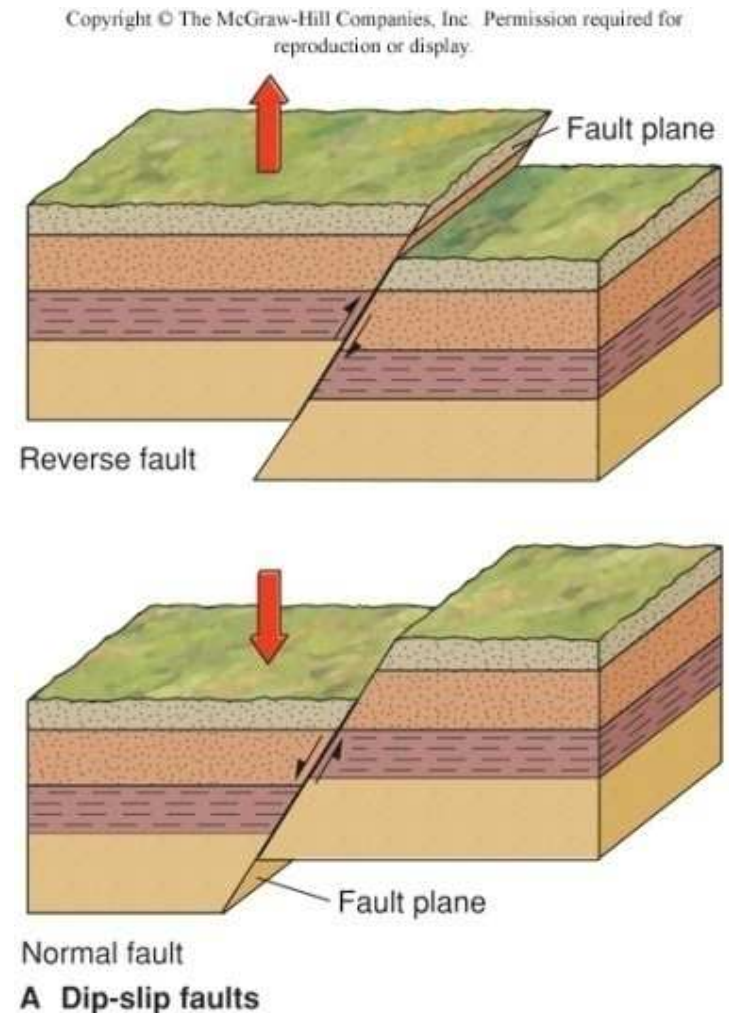

Copyright © The McGraw-Hill Companies, Inc. Permission required for reproduction or display.

Surface trace of fault

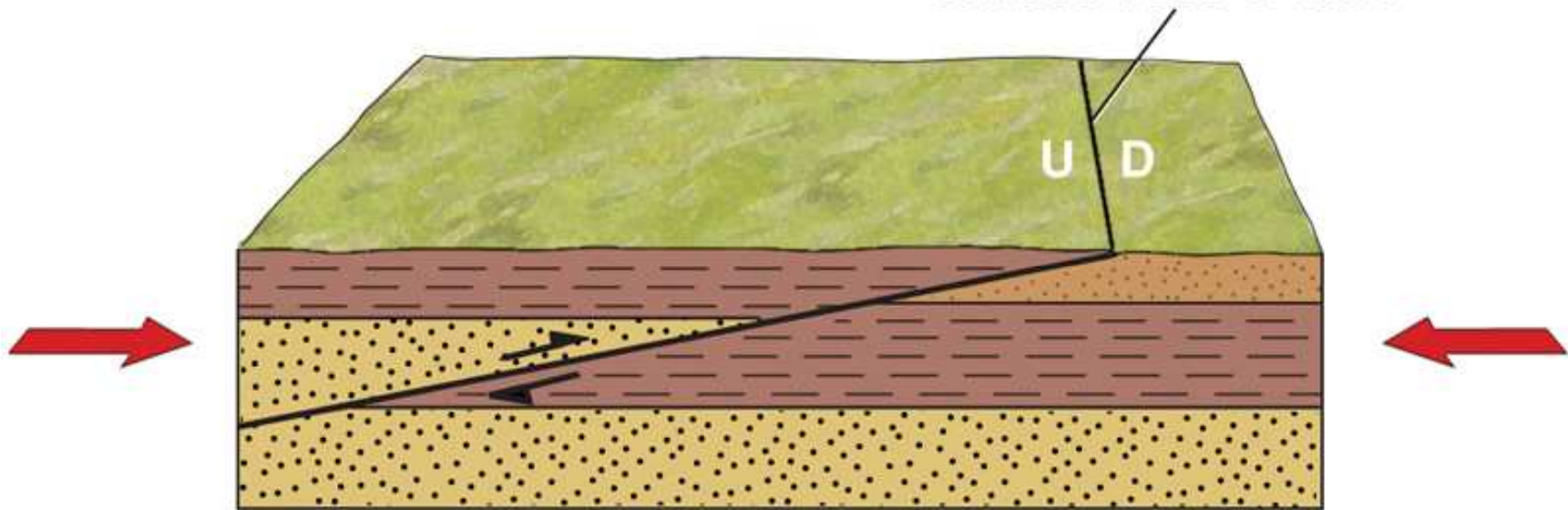

C

Thrust Fault (Reverse Fault)



A

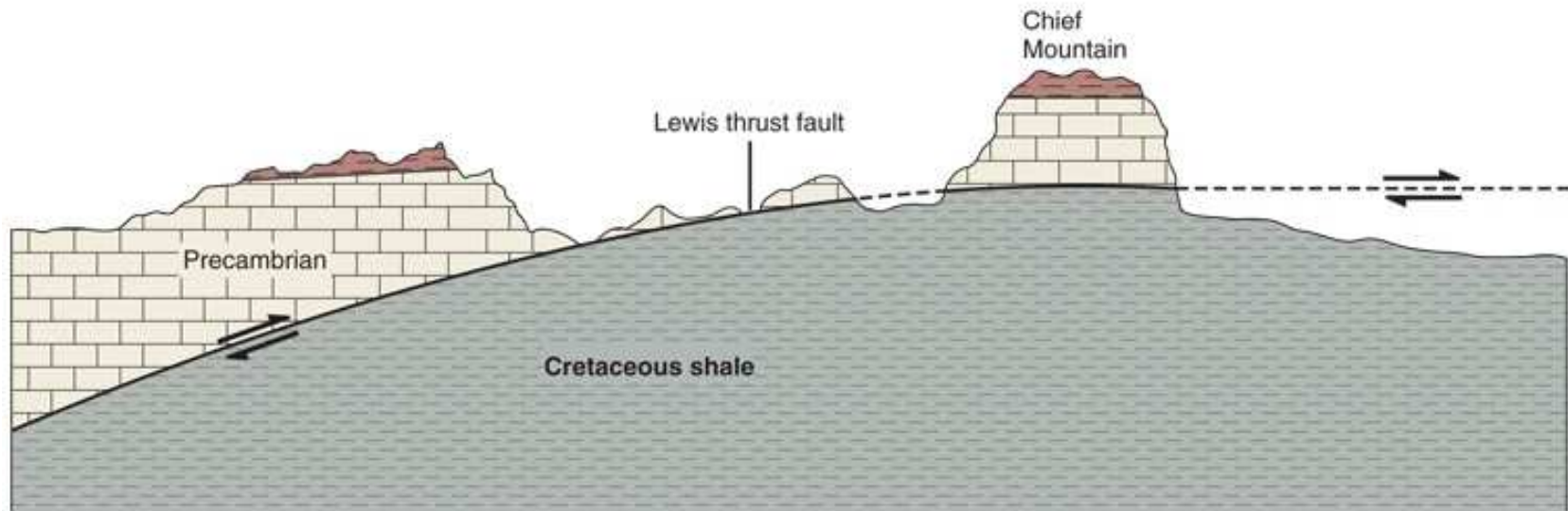

B

Frank M. Hanna

Chief Mountain in Glacier National Park, Montana : It is an erosional remnant of a major thrust fault (Lewis Thrust Fault)

Dip-slip Faults

- *Dip-slip faults* have movement parallel to the dip of the fault plane
 - Fault blocks, bounded by normal faults, that drop down or uplifted are known as *graben* and *horst*, respectively
 - Grabens associated with divergent plate boundaries are called *rifts*

Copyright © The McGraw-Hill Companies, Inc. Permission required for reproduction or display.

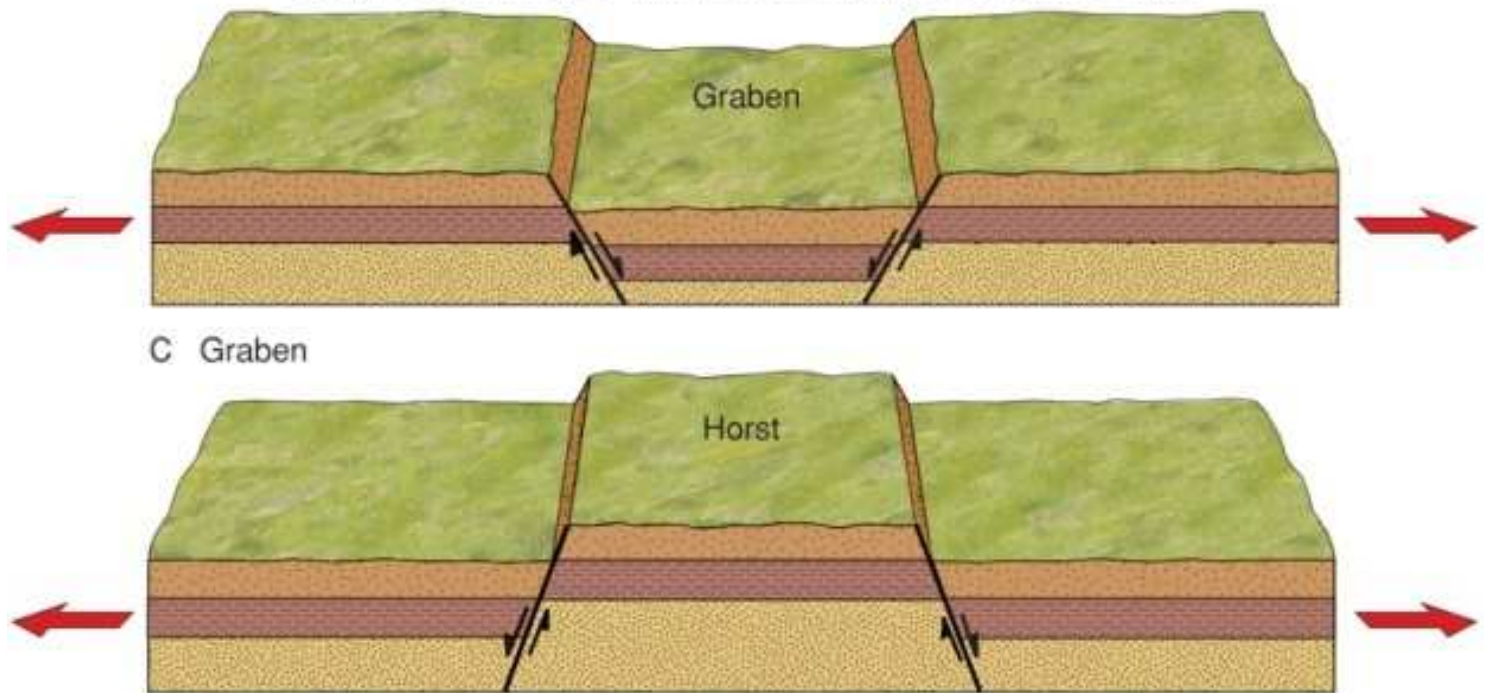

Copyright © The McGraw-Hill Companies, Inc. Permission required for reproduction or display.
Shaded part eroded away after faulting

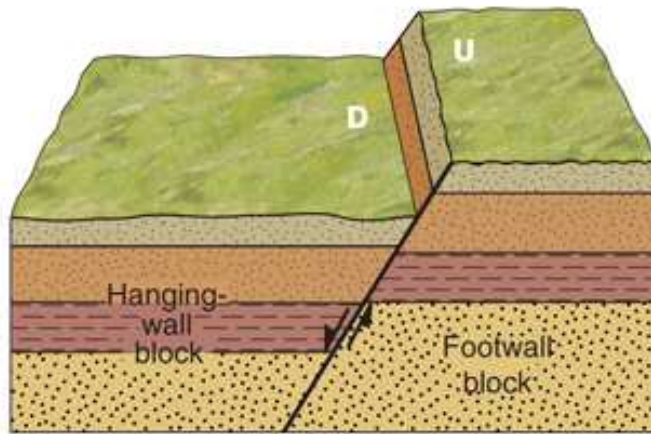

A Normal fault

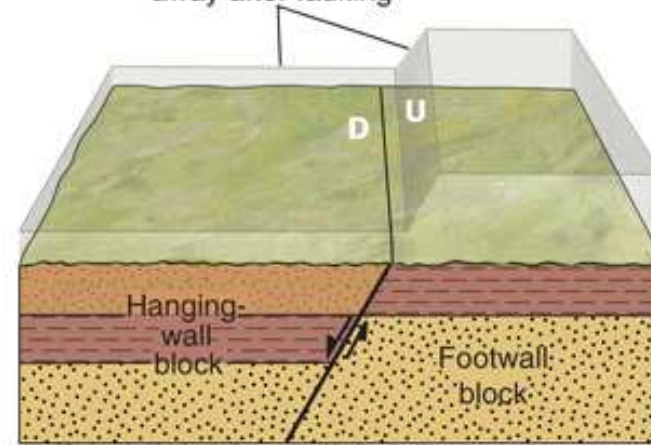

B Eroded normal fault

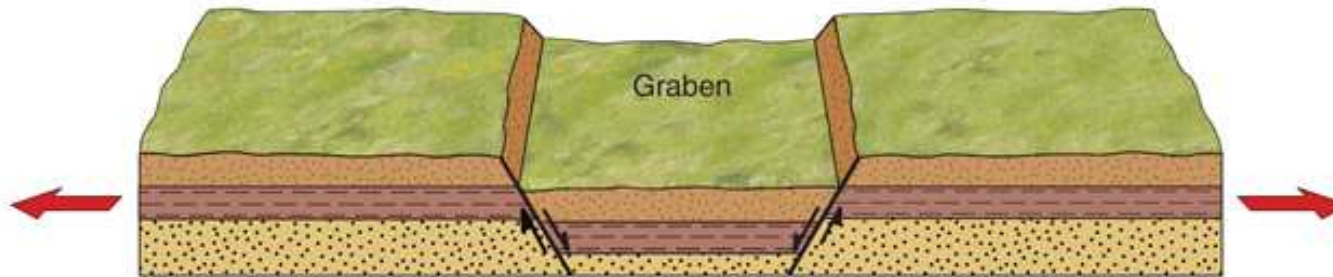

C Graben

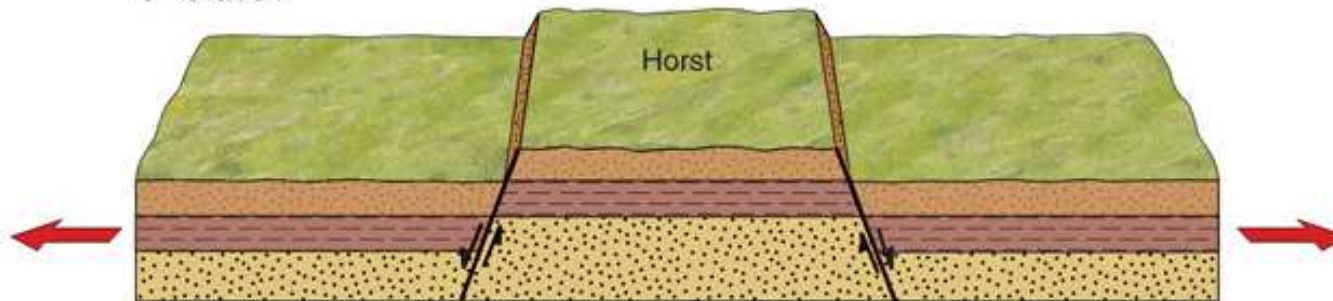

D Horst

Copyright © The McGraw-Hill Companies, Inc. Permission required for reproduction or display.

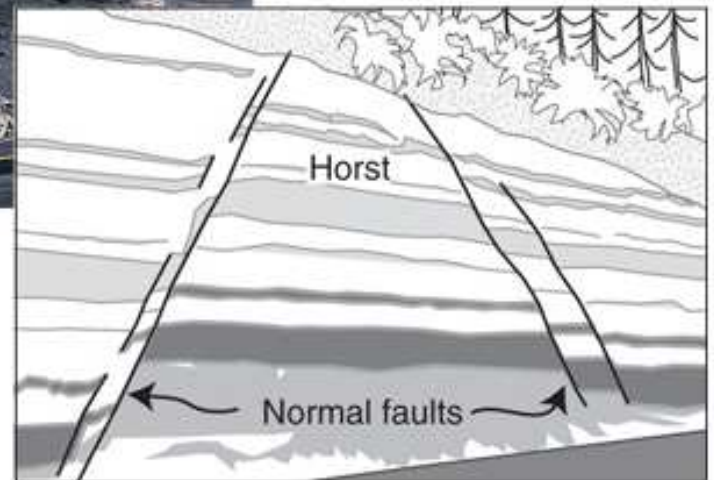

Diane Carlson

Types of Faults

- *Strike-slip faults* have movement that is predominantly horizontal and parallel to the strike of the fault plane
 - A viewer looking across to the other side of a *right-lateral* strike-slip fault would observe it to be offset to their right
 - A viewer looking across to the other side of a *left-lateral* strike-slip fault would observe it to be offset to their left

Copyright © The McGraw-Hill Companies, Inc. Permission required for reproduction or display.

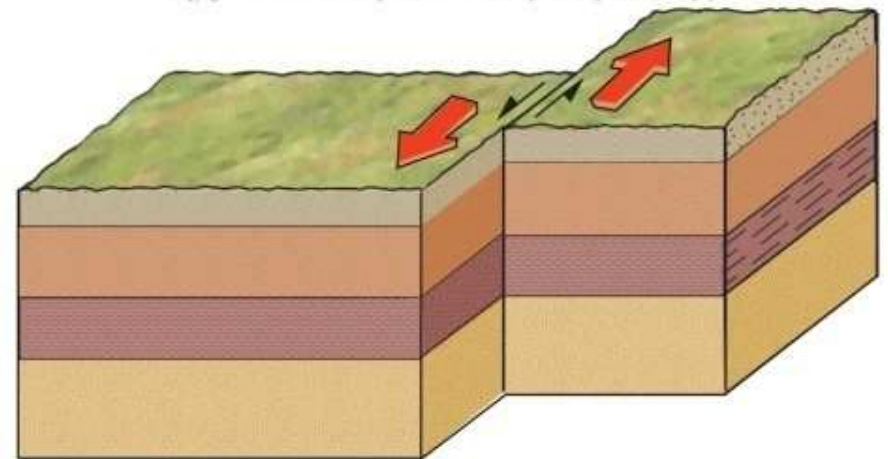

B Strike-slip fault

Copyright © The McGraw-Hill Companies, Inc. Permission required for reproduction or display.

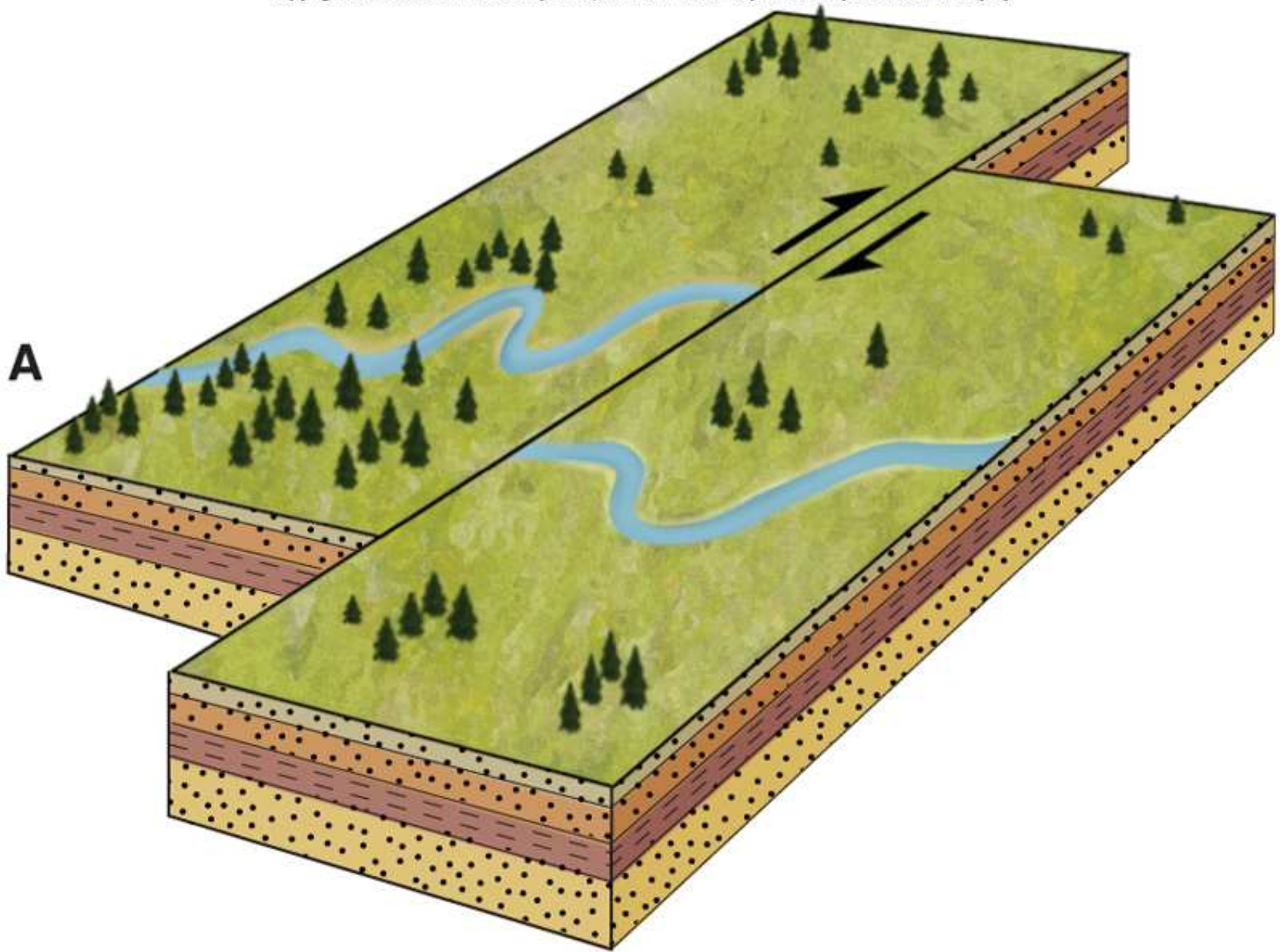

Copyright © The McGraw-Hill Companies, Inc. Permission required for reproduction or display.



C. C. Plummer

**Right-lateral - San
Andreas Fault**

Types of Faults

- *Oblique-slip faults* have movement with both vertical and horizontal components

Copyright © The McGraw-Hill Companies, Inc. Permission required for reproduction or display.

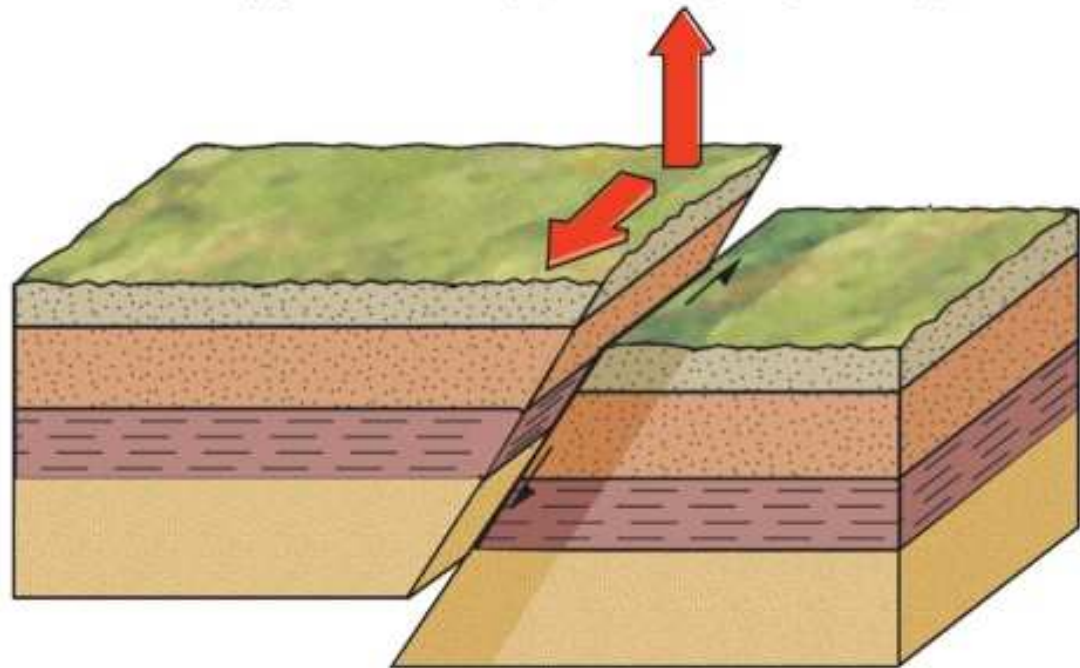

C Oblique-slip fault

Importance of Studying Structural Geology

- Infrastructure Development (dams, bridges, skyscrapers)
- Future earthquake or tectonic activity
- Oil and Natural Gas Exploration
- Precious Ore Mineral Exploration



B. Amundson

Copyright © The McGraw-Hill Companies, Inc. Permission required for reproduction or display.

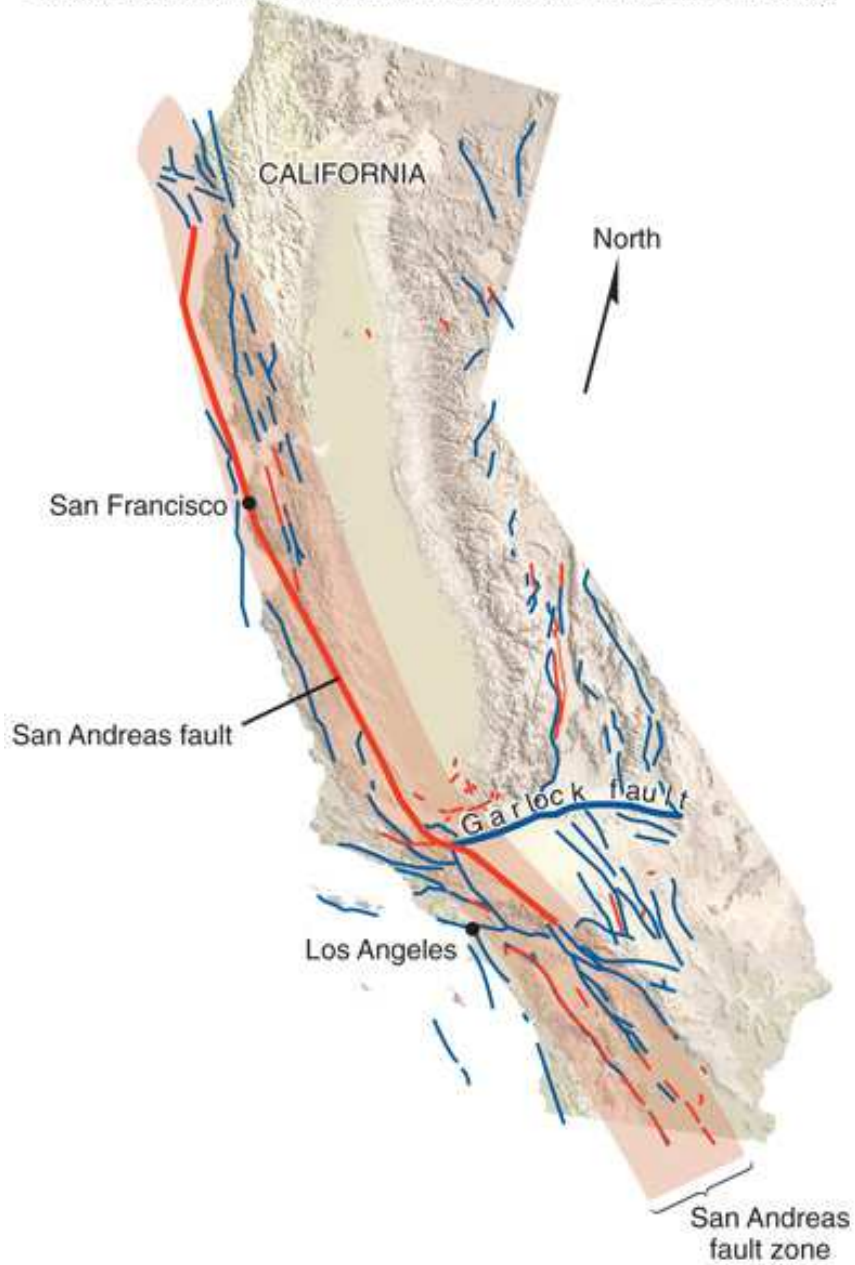

Copyright © The McGraw-Hill Companies, Inc. Permission required for reproduction or display.



A

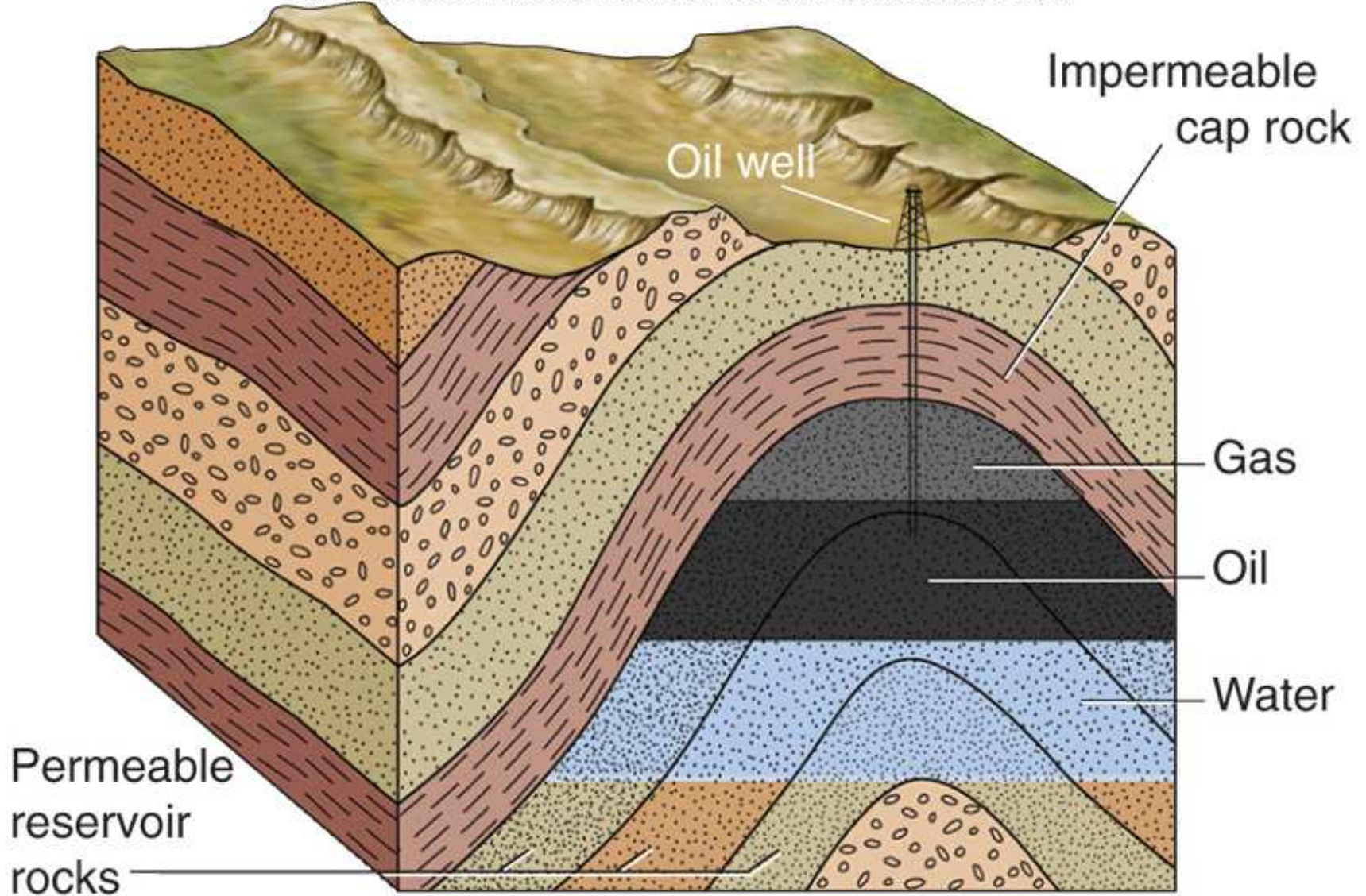

A

Copyright © The McGraw-Hill Companies, Inc. Permission required for reproduction or display.

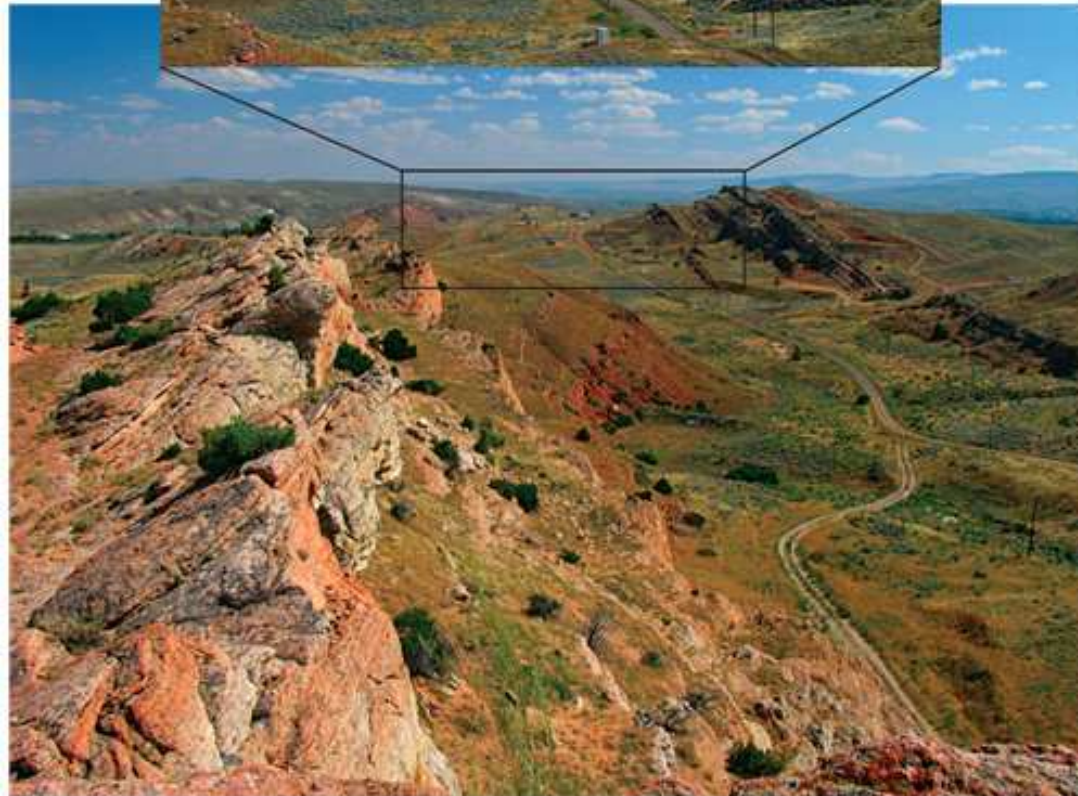

B

Diane Carlson

Copyright © The McGraw-Hill Companies, Inc. Permission required for reproduction or display.

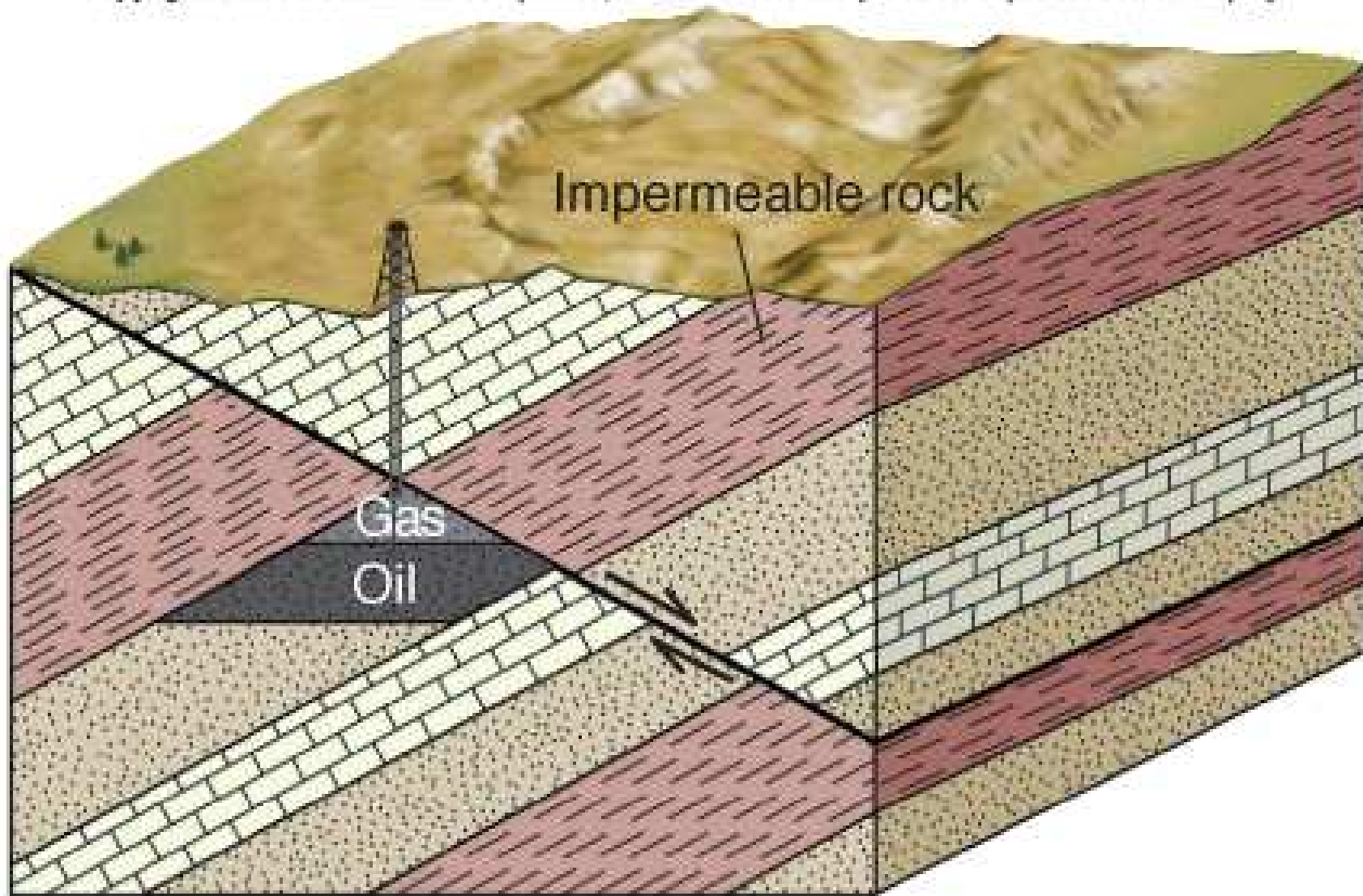

A Fault

Copyright © The McGraw-Hill Companies, Inc. Permission required for reproduction or display.

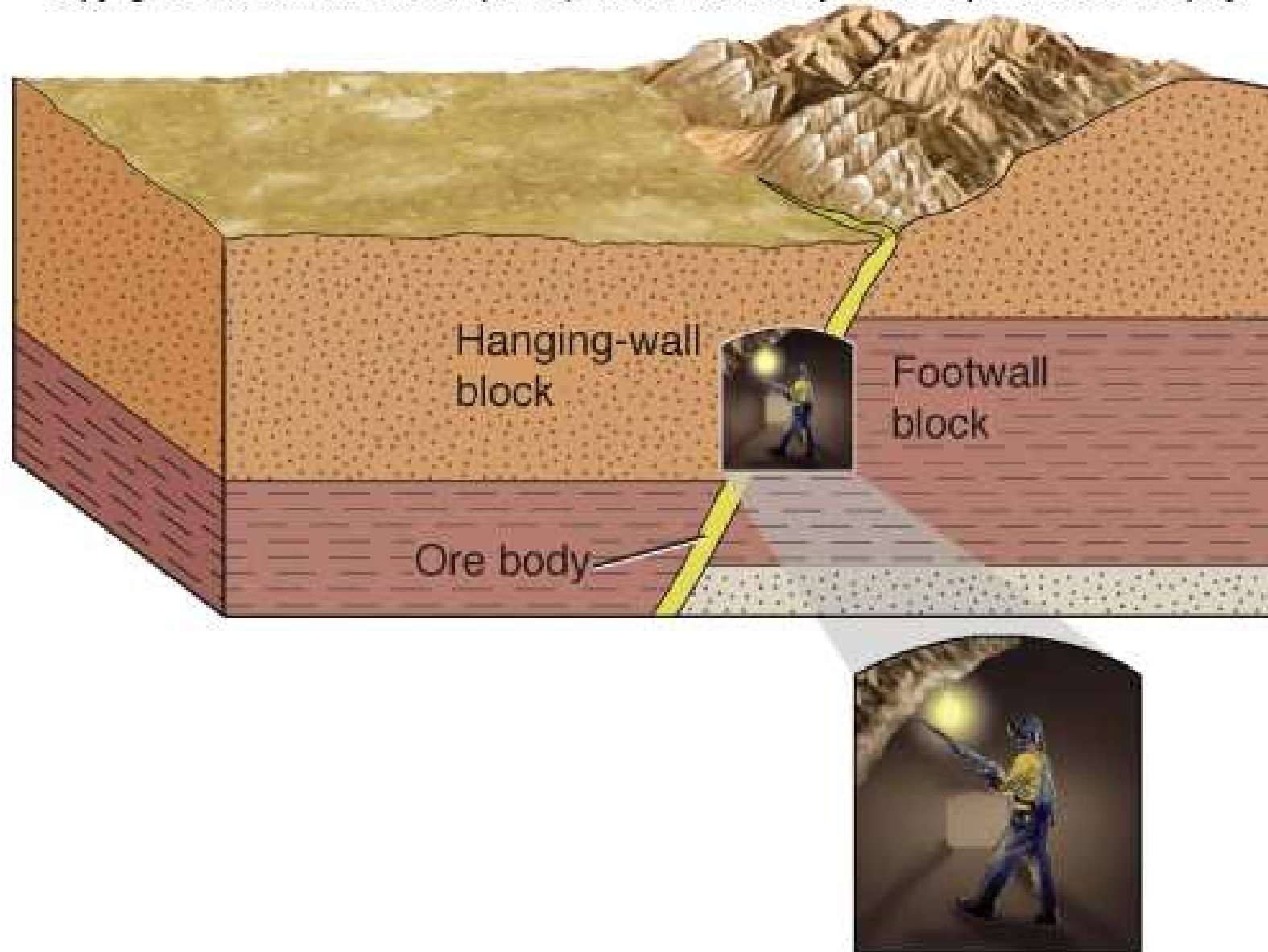

End of Chapter 6