

PWEagle

AWWA C900 & C905

PVC Water Transmission & Distribution Pipe

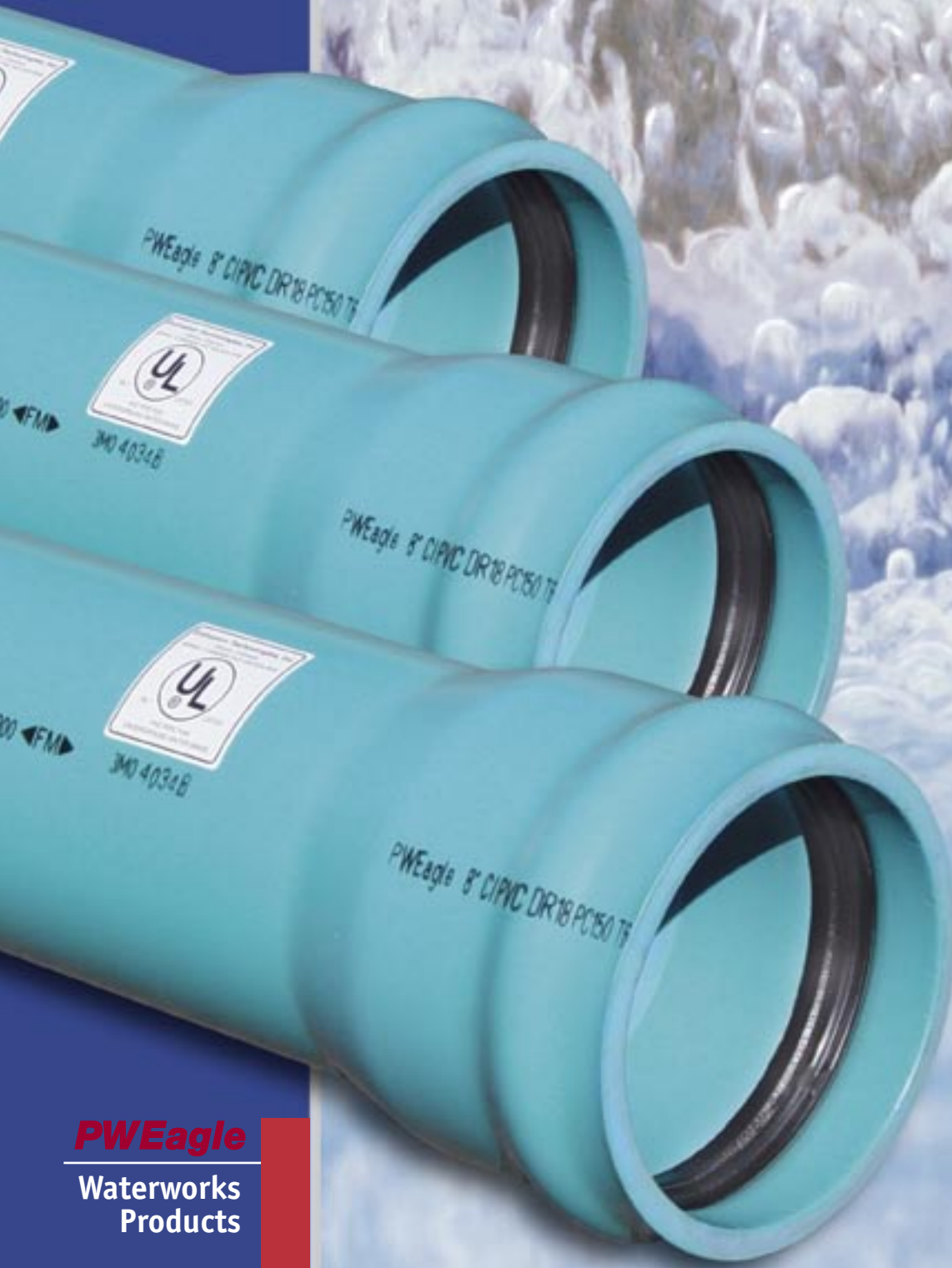

**Gasketed PVC
Water Pipe—
The Secure,
Reliable Choice
for Municipal
Systems**

PWEagle
Waterworks
Products

www.pweagleinc.com

Physical Requirements for AWWA C900 Pipe

Material: Pipe compound shall meet cell class 12454 per ASTM D1784 “Standard Specification for Polyvinyl Chloride (PVC) Compounds and Chlorinated Polyvinyl Chloride (CPVC) Compounds.”

Standard Laying Lengths: Standard laying lengths shall be 20 ft. (±1”) for all sizes.

Hydrostatic Test: Each length of pipe, including the joint, shall be tested to four times the pressure class of the pipe for a minimum of 5 seconds at the pressure listed in the table below.

PC 100	DR25	400 psi
PC 150	DR18	600 psi
PC 200	DR14	800 psi

Quick Burst Test: Randomly selected samples tested in accordance with ASTM D1599 shall withstand the pressures listed below when applied in 60 to 70 seconds.

PC 100	DR25	535 psi
PC 150	DR18	755 psi
PC 200	DR14	985 psi

Pipe Stiffness (F/Δy): The pipe stiffness for PVC Municipal Water Pipe is listed in the table below.

DR25	129 psi
DR18	364 psi
DR14	815 psi

Agency Listings:

Underwriter’s Laboratory (UL)
Factory Mutual (FM)
ANSI/NSF 61

Short Form Specification for AWWA C900

Scope: This specification designates general requirements for Polyvinyl Chloride (PVC) water distribution pipe in sizes 4-inch through 12-inch, with integral bell and spigot joints for the conveyance of water and other liquids.

Pipe: Pipe shall meet the requirements of AWWA C900 “Polyvinyl Chloride (PVC) Pressure Pipe and Fabricated Fittings, 4-Inch through 12-Inch, for Water Distribution.”

Other Requirements:

- Provisions must be made for expansion and contraction at each joint with an elastomeric seal.
- The bell shall consist of an integral thickened wall section with an elastomeric seal. The wall thickness in the bell section shall conform to the requirements of Section 6.2 of ASTM D3139, “Standard Specification for Joint for Plastic Pressure Pipes Using Flexible Elastomeric Seals.”
- When used for potable water systems, pipe shall meet the requirements of ANSI/NSF 61 “Drinking Water System Components — Health Effects.”
- The pipe shall be manufactured to cast iron outside diameters (CIOD) in accordance with AWWA C900.
- The seal shall meet the requirement of ASTM F477 “Standard for Elastomeric Seals (Gaskets) for Joining Plastic Pipe.”



Physical Requirements for AWWA C905

Material: Pipe compound shall meet cell class 12454 per ASTM D1784 “Standard Specification for Polyvinyl Chloride (PVC) Compounds and Chlorinated Polyvinyl Chloride (CPVC) Compounds.”

Standard Laying Lengths: Standard laying lengths shall be 20 ft. (±1”) for all sizes.

Hydrostatic Test: Each length of pipe, including the joint, shall be tested to two times the pressure rating of the pipe for a minimum of 5 seconds at the pressure listed in the table below.

PR 165	DR25	330 psi
PR 235	DR18	470 psi

Agency Listing:

ANSI/NSF 61

Short Form Specification for AWWA C905 Pipe

Scope: This specification designates general requirements for Polyvinyl Chloride (PVC) water transmission and distribution pipe in sizes 14-inch through 24-inch, with integral bell and spigot joints for the conveyance of water and other liquids.

Pipe: Pipe shall meet the requirements of AWWA C905 “Polyvinyl Chloride (PVC) Pressure Pipe and Fabricated Fittings, 14-inch through 48-inch, for Water Transmission and Distribution”.

Other Requirements:

- Provisions must be made for expansion and contraction at each joint with an elastomeric seal.
- The bell shall consist of an integral thickened wall section with an elastomeric seal. The wall thickness in the bell section shall conform to the requirements of Section 6.2 of ASTM D3139, “Standard Specification for Joint for Plastic Pressure Pipes Using Flexible Elastomeric Seals.”
- When used for potable water systems, pipe shall meet the requirements of ANSI/NSF 61 “Drinking Water System Components — Health Effects.”
- The pipe shall be manufactured to cast iron outside diameters (CIOD) in accordance with AWWA C905.
- The seal shall meet the requirements of ASTM F477 “Standard for Elastomeric Seals (Gaskets) for Joining Plastic Pipe.”

The Sealing System

PW Eagle's joints employ gasket systems that have excellent track records in the field. The joining systems are factory-made with rubber gaskets installed in the ring groove at the time of manufacture. The gaskets are designed to retain in the ring groove. When assembly technique is consistent with PW Eagle instructions, the secured gasket systems will not displace.

The gaskets are classified to ANSI/NSF Standard 61.

Cross-Sectional Views

The following drawings show the cross-sectional views of the pipe before and after assembly. When the pipes are pushed together the rubber in the seal is compressed. Compression gives rise to a sealing pressure that acts on the socket and spigot as shown in the illustration below.

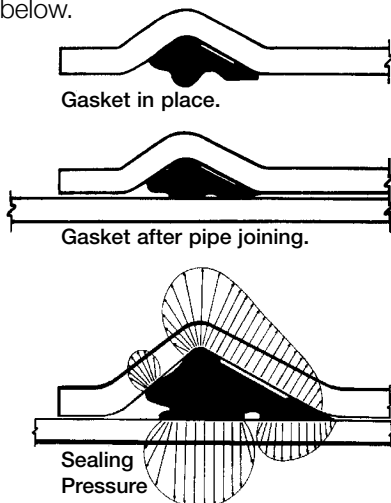

NOTE: Gasket drawings are representations. Actual gaskets may vary from drawings

Installation Advantages of the PW Eagle Joint

The gasket is factory installed, so there are no gaskets to install on the job site. This avoids the possibility of installing the wrong gasket or improperly installing the correct gasket. The installer should leave the factory-installed gasket in place and simply follow PW Eagle Joint Assembly instructions for problem-free joint performance.

Installation Standard

AWWA C900 and C905 pipe should be installed in accordance with AWWA C605 "Underground Installation of Polyvinyl Chloride (PVC) Pressure Pipe and Fittings for Water."

Joint Assembly

PW Eagle's C900 and C905 pipe will arrive on the job site with the gasket installed at the factory, ready for assembly.

Assemble as follows:

1. Inspect the bell and remove any foreign matter such as mud, sand or ice. **DO NOT REMOVE THE GASKET FROM THE PIPE.**
2. Clean off the spigot end of the pipe and apply lubricant evenly, covering the beveled nose and sealing surface up to the stop mark. **NOTE:** Use only lubricant supplied by PW Eagle – the use of other lubricants may cause deterioration of pipe or gasket.
3. Place the beveled end in the companion bell and provide straight alignment.
4. Push the pipe straight into the bell with a block and bar until the stop mark on the spigot is even with the end of the bell.
5. **NOTE: DO NOT ASSEMBLE THE JOINT BY SWINGING OR STABBING.**
6. **NOTE:** For larger sizes of pipe, additional mechanical assistance (such as a come-along or hydraulic jack). **DO NOT ASSEMBLE THE JOINT USING A BACKHOE BUCKET.**

7. Allowable axial deflection at the joint varies with each manufacturer's design. For PW Eagle products, allowable deflection is two degrees. For more information, see PW Eagle's technical bulletin "Gasketed Pipe Assembly."

Tapping PVC – C900

PW Eagle's C900 and C905 pipe may be tapped either dry or under pressure. There are three types of tapping equipment and methods.

1. Direct Tapping

The only pipes that may be direct-tapped are C900 DR14 and DR18 in sizes 6-inch through 12-inch. When direct tapping, follow the procedures in Uni-Bell's Uni-B-8 "Recommended Practice for the Direct Tapping of Polyvinyl Chloride (PVC) Pressure Water Pipe."

2. Saddle Tapping

All sizes and DRs of C900 and C905 may be saddle-tapped. Maximum tap size is 2 inches for saddles. Service clamps or saddles used with PVC pipe must:

- a. be designed for use with CIOD PVC pipe
- b. provide full support around the circumference of the pipe
- c. provide bearing area of sufficient width along the axis of the pipe (minimum 2-inch width for taps up to 1 inch diameter; minimum 3-inch width for taps 1 ¼ to 2 inch diameter)

3. Tapping Sleeve or Valve

All sizes and DRs of C900 and C905 may be tapped using a tapping sleeve or valve. For connections greater than 2 inches in diameter, this method is required. Maximum connection is size-on-size.



Gasketed AWWA C900 & C905 Transmission & Distribution pipe is the clear choice for municipal applications.

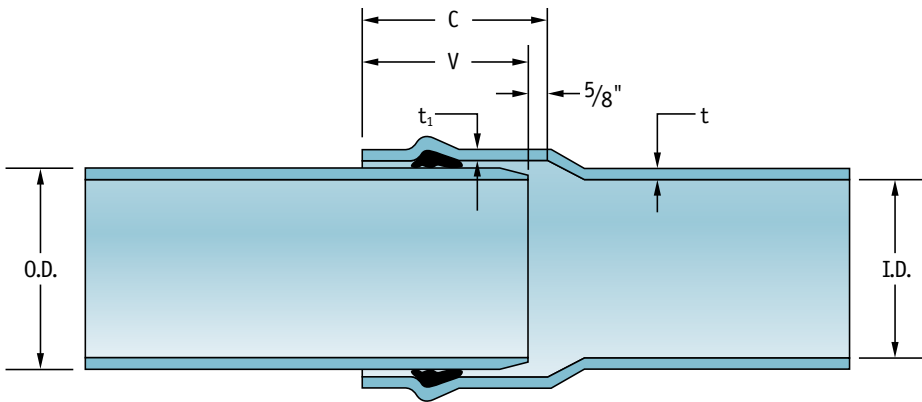

V - For field cuts, draw a stop mark (line "V") by subtracting 5/8" from bell length "C".

WARNING:

Do not use PVC pipe to convey air or other gases under pressure. If failure should occur, the result would be catastrophic. Rapid expansion of the compressed gas would send shards of plastic over a wide area and could result in serious injury or death.

Pipe Dimensions & Weights

Nominal Pipe Size (inches)	DR	Average Pipe OD (inches)	Approx Pipe ID (inches)	Min Wall Thickness (t) (inches)	Min Bell Thickness (t ₁) (inches)	Approx Bell OD (inches)	Approx Weight (lbs/100ft)	Approx Weight (lbs/pc)
4	25	4.80	4.42	.192	.207	6 ⁷ / ₈	190	38
4	18	4.80	4.27	.267	.298	6 ⁷ / ₈	260	52
4	14	4.80	4.11	.343	.394	6 ⁷ / ₈	320	64
6	25	6.90	6.35	.276	.300	9 ¹ / ₂	390	78
6	18	6.90	6.13	.383	.429	9 ¹ / ₂	530	106
6	14	6.90	5.91	.493	.567	9 ¹ / ₂	670	134
8	25	9.05	8.33	.362	.395	12 ¹ / ₈	670	134
8	18	9.05	8.04	.503	.562	12 ¹ / ₈	910	182
8	14	9.05	7.76	.646	.743	12 ¹ / ₈	1150	230
10	25	11.10	10.21	.444	.483	14 ⁷ / ₈	1010	202
10	18	11.10	9.87	.617	.690	14 ⁷ / ₈	1370	274
10	14	11.10	9.51	.793	.912	14 ⁷ / ₈	1730	346
12	25	13.20	12.14	.528	.574	17 ³ / ₈	1420	284
12	18	13.20	11.73	.733	.820	17 ³ / ₈	1940	388
12	14	13.20	11.31	.943	1.085	17 ³ / ₈	2450	490
14	25	15.30	14.08	.612	.666	19 ¹ / ₂	1890	378
14	18	15.30	13.60	.850	.960	19 ¹ / ₂	2580	516
16	25	17.40	16.01	.696	.760	21 ⁷ / ₈	2470	494
16	18	17.40	15.47	.967	1.095	21 ⁷ / ₈	3380	676
18	25	19.50	17.83	.780	.852	24 ³ / ₈	3110	622
18	18	19.50	17.18	1.083	1.225	24 ³ / ₈	4250	850
20	25	21.60	19.75	.864	.943	26 ⁷ / ₈	3840	768
20	18	21.60	19.03	1.200	1.356	26 ⁷ / ₈	5250	1050
24	25	25.80	23.59	1.032	1.127	31 ¹ / ₈	5440	1088

Customer Service Centers

Oregon 800-347-0200
Fax 541-686-9257

Missouri 800-341-0053
Fax 573-474-1760

West Virginia 800-624-3111
Fax 304-472-0742



P.O. Box 10049, Eugene, OR 97440 • (800) 347-0200 • (541) 343-0200 • FAX (541) 686-9257 • www.pweagleinc.com