

Machine inserted corporation stops were developed by Hieronymus Mueller in conjunction with his development of the drilling and tapping machine used to make pressure taps in water mains. During the development of the machine inserted corporation stop, Mr. Mueller designed an inlet thread which became known as the MUELLER or “CC” thread. This thread form was eventually adopted by the American Water Works Association and is listed in ANSI/AWWA Standard C800 as the AWWA Taper thread.

MUELLER Co. pioneered other design concepts in the waterworks industry such as the copper flare connection, MUELLER 110® Compression Con-

nection and the MUELLER ORISEAL® Valves, which use O-ring seals to assure leak-tight performance.

MUELLER Co. offers corporation stops in three designs: machined key (commonly referred to as ground key), ORISEAL type (1-1/2" and 2" sizes only) and ball type.

All three designs are available with a wide range of inlet/outlet combinations including the MUELLER 110 Compression Connection and Pack Joint Connection. These three designs are all compatible with the MUELLER line of drilling and tapping machines, and small drilling machines.

MUELLER 300™ Ball Type Corporation Valves

- ❑ BLOW-OUT PROOF STEM DESIGN - prevents separation and assures dependable, safe operation.
- ❑ HEAVY BRASS COMPONENTS are constructed of 85-5-5-5 ASTM B62 brass for strength and durability.
- ❑ STRAIGHT-DESIGN allows maximum flow with minimum pressure loss.
- ❑ MANUFACTURED AND TESTED - to ANSI/AWWA C800 standard.
- ❑ DOUBLE O-RING STEM SEALS - are supported in precision machined grooves and provide secure, leak tight sealing.
- ❑ INLET THREADS - are either AWWA taper (MUELLER “CC”) or AWWA iron pipe.
- ❑ STAINLESS STEEL REINFORCED SEAT SEAL - assures reliable seal under full flow and pressure.
- ❑ END PIECE O-RING provides secondary seal to prevent leakage.
- ❑ 300 PSIG -maximum working pressure.
- ❑ EXTRA STRONG - key to ball connection provides strong, reliable performance and resists breakage.
- ❑ OUTLETS - include copper flare connection, MUELLER 110 Compression Connection, MUELLER INSTA-TITE, Pack Joint Connection and iron pipe thread connection.
- ❑ STEM ROTATION - full 360 degree.
- ❑ FLUOROCARBON COATED BALL - ensures smooth, easy turning operation.

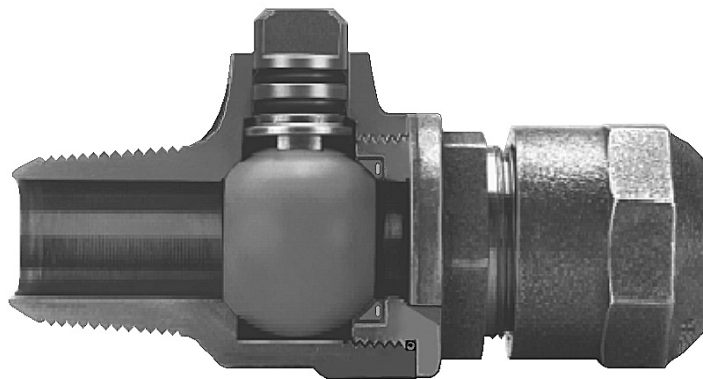

The MUELLER ORI-CORP® Corporation Valve is an easy turning, O-ring sealed, balanced pressure, plug type valve having a round, full open unobstructed flow way. These valves also feature a heavy one-piece bronze body with integral wrench flats.

The integral plug and key head construction provides maximum strength and positive operation. The large operating head provides more than adequate wrench gripping area for easy operation.

MUELLER ORI-CORP Corporation Valve

- ❑ **INTEGRAL WRENCH FLATS** on inlet and outlet of body provide generous wrench gripping area.
- ❑ **TOP SEALING O-RING** - seals valve from exterior leakage and adds to easy turning qualities.
- ❑ **LARGE OPERATING HEAD** - provides more than adequate wrench gripping area.
- ❑ **INTEGRAL ONE-PIECE PLUG AND OPERATING HEAD** provides strength and assures positive operation. Quarter turn in either direction activates valve. An integrally cast flange at the top of the plug functions as a dirt seal to protect the top O-ring.
- ❑ **INLET** - is available with either AWWA taper (MUELLER "CC") thread or AWWA iron pipe thread.
- ❑ **STRONG, ONE PIECE BODY** - has no cavities that could allow debris to collect and cause damage to the plug.
- ❑ **FULL FLOW** - round way plug opening provides straight through passage with no obstruction.
- ❑ **BRONZE RETAINING RING** secures plug in body and also functions as a dirt seal to protect bottom O-ring. Since this valve is a balanced pressure type, there is no force tending to eject the plug or load the retaining mechanism.
- ❑ **BOTTOM SEALING O-RING** - seals valve from leakage and adds to easy turning qualities.
- ❑ **OUTLET PORT SEALING O-RING** is totally confined in a machined groove to provide positive leak-tight shutoff.
- ❑ **INTEGRAL OUTLET** is available with either MUELLER 110® Conductive Compression Connection, outside iron pipe thread or inside iron pipe thread.
- ❑ **175 PSIG** - maximum working pressure.



MUELLER CO. has been manufacturing ground key corporation stops since 1870 and many features of the modern day stops were developed by MUELLER CO.

These features include a brass alloy, and inlet thread and outlet connections that were eventually adopted as American Water Works Association Standards.

MUELLER® Ground Key Design Corporation Valves

- ❑ BODY - is cast from 85-5-5-5 ASTM B62 brass alloy for strength and corrosion resistance.
- ❑ INTEGRAL OUTLET available with a wide variety of outlet end connections including the MUELLER 110® Compression Connection, MUELLER Pack Joint Connection, MUELLER INSTA-TITE® Connection, copper flare, inside iron pipe, outside iron pipe, increasing iron pipe, MUELLER Coupling Thread and other popular connections.
- ❑ STRAIGHT THROUGH DESIGN - allows maximum flow with minimum pressure loss.
- ❑ KEY AND BODY - are precision machined to assure sealing surfaces match.
- ❑ INLET THREADS are either AWWA taper thread (MUELLER "CC") or AWWA iron pipe thread.
- ❑ MANUFACTURED AND TESTED - to ANSI/AWWA C800 Standard.
- ❑ 100 PSIG - maximum working pressure for 1/2," 3/4" and 1" sizes. 80 PSIG - maximum working pressure for 1-1/4", 1-1/2" and 2" sizes.
- ❑ "D" SHAPED WASHER - turns with key to prevent loosening of key nut.
- ❑ KEY NUT - is designed so overtightening will strip stem threads instead of breaking stem.

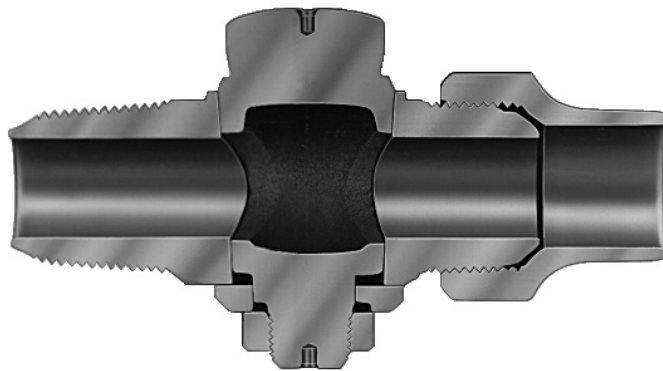

Corporation valve inlet threads

- ❑ AWWA taper (MUELLER "CC") thread.
- ❑ AWWA iron pipe thread.

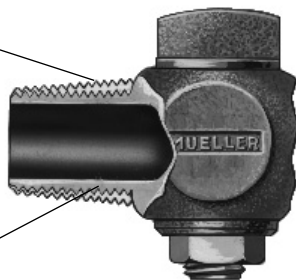

MUELLER Screw plug thread

- ❑ Increasing I.P. thread is one size larger than inlet.
- ❑ Screw plug thread is same nominal size as inlet.



5.4



Rev. 9-09 Shaded area indicates changes

3/4" - 2" MUELLER® 300™ BALL CORPORATION VALVES

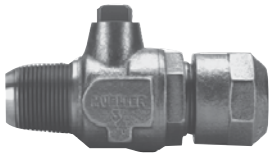

B-25008

MUELLER® 300™ Ball Corporation Valve
Inlet: AWWA taper (MUELLER "CC") thread
Outlet: MUELLER® 110® Conductive Compression Connection for CTS O.D.* tubing

3/4"	3/4" x 1"	1"	1-1/2"	1-1/2" x 2"	2"
------	-----------	----	--------	-------------	----



B-25028

MUELLER® 300™ Ball Corporation Valve
Inlet: AWWA I.P. thread
Outlet: MUELLER® 110® Conductive Compression Connection for CTS O.D. tubing

3/4"	3/4" x 1"	1"	1-1/2"	1-1/2" x 2"	2"
------	-----------	----	--------	-------------	----

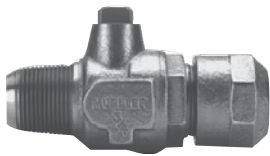

B-25009

MUELLER 300 Ball Corporation Valve
Inlet: AWWA taper (MUELLER "CC") thread
Outlet: MUELLER® 110® Compression Connection for IPS PE* pipe

3/4"	3/4" x 1"	1"
------	-----------	----



B-25029

MUELLER 300 Ball Corporation Valve
Inlet: AWWA I.P. thread
Outlet: MUELLER 110® Compression Connection for IPS PE* pipe

3/4"	3/4" x 1"	1"
------	-----------	----

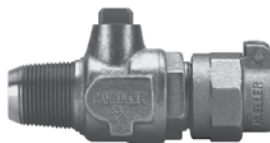

E-25009

MUELLER 300 Ball Corporation Valve
Inlet: AWWA taper (MUELLER "CC") thread
Outlet: MUELLER Pack Joint for IPS PE* pipe
 **Note: 3/4" size only may also be used on PVC

3/4"***	1"	1-1/2"	2"
---------	----	--------	----

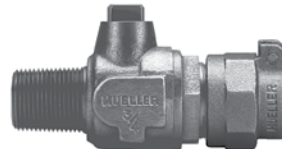

E-25029

MUELLER 300 Ball Corporation Valve
Inlet: AWWA I.P. thread
Outlet: MUELLER Pack Joint for IPS PE* pipe
 **Note: 3/4" size only may also be used on PVC

3/4"***	1"	1-1/2"	2"
---------	----	--------	----

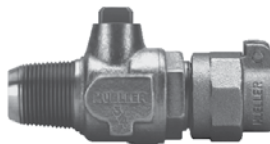

V-25056

MUELLER 300 Ball Corporation Valve
Inlet: AWWA taper (MUELLER "CC") thread
Outlet: MUELLER Pack Joint for IPS PVC* pipe

1"	1-1/2"	2"
----	--------	----

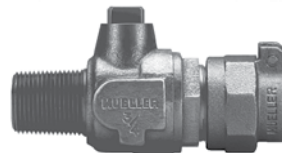

V-25058

MUELLER 300 Ball Corporation Valve
Inlet: AWWA I.P. thread
Outlet: MUELLER Pack Joint for IPS PVC* pipe

1"	1-1/2"	2"
----	--------	----



P-25008

MUELLER 300 Ball Corporation Valve
Inlet: AWWA taper (MUELLER "CC") thread
Outlet: MUELLER Pack Joint Connection for CTS O.D.* tubing

3/4"	3/4"x1"	1"	1-1/2"	1-1/2"x2"	2"
------	---------	----	--------	-----------	----

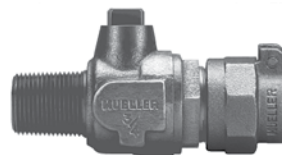

P-25028

MUELLER 300 Ball Corporation Valve
Inlet: AWWA I.P. thread
Outlet: MUELLER Pack Joint Connection for CTS O.D.* tubing

3/4"	3/4" x 1"	1"	1-1/2"	1-1/2" x 2"‡	2"
------	-----------	----	--------	--------------	----

*See charts on pages 5.12-5.16 for tubing and pipe that may be used with these connections.

NOTE: Sizes shown above represent nominal size of inlet and outlet connections. When two sizes are given, the first is size of inlet and the second is size of outlet.

‡ Requires minimum ordering quantity. Contact MUELLER Customer Service Center for minimum order requirements and availability.

MUELLER Corporation Valves are manufactured and tested in accordance with ANSI/AWWA C800.

3/4" - 2" MUELLER® 300™ BALL CORPORATION VALVES



B-25006

MUELLER® 300™ Ball Corporation Valve
AWWA taper (MUELLER “CC”) thread
MUELLER® INSTA-TITE® Connection for CTS PE* pipe

3/4"	1"
------	----



B-25024

MUELLER® 300™ Ball Corporation Valve
AWWA I.P. thread
MUELLER® INSTA-TITE® Connection for CTS PE* pipe

3/4"	1"
------	----



B-25005

MUELLER 300 Ball Corporation Valve
AWWA taper (MUELLER “CC”) thread
MUELLER® INSTA-TITE® Connection for IPS PE* pipe

3/4"	1"
------	----



B-25026

Corporation Valve
AWWA I.P. thread
MUELLER® INSTA-TITE® Connection for IPS PE* pipe

3/4"	1"
------	----



B-25000

MUELLER 300 Ball Corporation Valve
Inlet: AWWA taper (MUELLER “CC”) thread
Outlet: Copper flare straight connection

3/4"	3/4" x 1"	1"	1-1/2"	2"
------	-----------	----	--------	----



B-25025

MUELLER 300 Ball Corporation Valve
Inlet: AWWA I.P. thread
Outlet: Copper flare straight connection

3/4"	3/4" x 1"	1"	1-1/2"	2"
------	-----------	----	--------	----



B-25020

MUELLER 300 Ball Corporation Valve
Inlet: AWWA taper (MUELLER “CC”) thread
Outlet: Copper flare x 90 Bend CS

3/4"	1"	1-1/2"	2"
------	----	--------	----



B-25010

MUELLER 300 Ball Corporation Valve
Inlet: AWWA taper (MUELLER “CC”) thread
Outlet: Copper flare x 45 Bend

1-1/2"	2"
--------	----

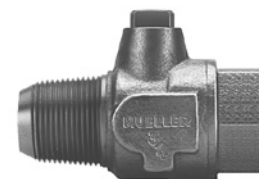

B-20045

MUELLER 300 Ball Corporation Valve
Inlet: AWWA taper (MUELLER “CC”) thread
Outlet: F.I.P. thread

3/4"	3/4"x1"	1"	1-1/2"	2"
------	---------	----	--------	----

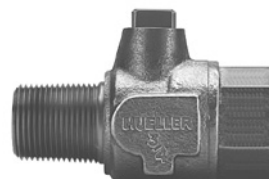

B-20046

MUELLER 300 Ball Corporation Valve
Inlet: AWWA I.P. thread
Outlet: F.I.P. thread

3/4"	3/4"x1"	1"	1-1/2"	2"
------	---------	----	--------	----

*See charts on pages 5.12-5.16 for tubing and pipe that may be used with these connections.

NOTE: Sizes shown above represent nominal size of inlet and outlet connections. When two sizes are given, the first is size of inlet and the second is size of outlet.

For identification purposes MUELLER INSTA-TITE Connections for CTS O.D. PE tubing have red gripper rings, and the connections for IPS PE pipe have white gripper rings.

MUELLER® Corporation Valves are manufactured and tested in accordance with ANSI/AWWA C800.

5.6



3/4" - 2" MUELLER® 300™ BALL CORPORATION VALVES

Rev. 9-09 Shaded area indicates changes



B-2996

MUELLER 300 Ball Corporation Valve
Inlet: AWWA taper (MUELLER "CC") thread
Outlet: M.I.P. thread

3/4"	1"	1-1/2"	2"
------	----	--------	----



B-20013

MUELLER 300 Ball Corporation Valve
Inlet: AWWA I.P. thread
Outlet: M.I.P. thread (Full size diameter inlet to outlet)

3/4"	1"	1-1/2"	2"
------	----	--------	----



B-20003

MUELLER 300 Ball Corporation Valve
Inlet: AWWA taper (MUELLER "CC") thread
Outlet: Increasing M.I.P. thread

3/4"	1"	1-1/2"	2"
------	----	--------	----



B-2969

MUELLER 300 Ball Corporation Valve
Inlet: AWWA I.P. thread
Outlet: M.I.P. thread (Full size diameter inlet to outlet).

1-1/2"	2"
--------	----

OPTIONAL T-HEAD:

All ball corporation valves are available with a 360° turn T-head cap by adding "-10" to catalog number: Example: B-25008-10
 For a 3/4" or 1" detachable T-head caps for corporation valves add "-00" to catalog number. Example: B-25008-00

RECLAIMED WATER STYLE:

All ball corporation valves are available marked for "reclaimed water" by adding "-20" to the catalog number. Example: B-25008-20.

NOTE: Sizes shown above represent nominal size of inlet and outlet connections. When two sizes are given, the first is size of inlet and the second is size of outlet.

1-1/2" & 2" MUELLER® ORI-CORP® CORPORATION VALVES



5.7

Rev. 4-01



H-15013

MUELLER ORI-CORP Corporation Valve
Inlet: AWWA taper (MUELLER "CC") thread
Outlet: MUELLER® 110® Conductive Compression Connection for CTS O.D.* tubing

1-1/2"	2"
--------	----



H-15023

MUELLER ORI-CORP Corporation Valve
Inlet: AWWA I.P. thread
Outlet: MUELLER 110 Conductive Compression Connection for CTS O.D.* tubing

1-1/2"	2" **
--------	-------



P-15013

MUELLER ORI-CORP Corporation Valve
Inlet: AWWA taper (MUELLER "CC") thread
Outlet: MUELLER Pack Joint Connection for CTS O.D.* tubing

1-1/2"	2"
--------	----



P-15023

MUELLER ORI-CORP Corporation Valve
Inlet: AWWA I.P. thread
Outlet: MUELLER Pack Joint Connection for CTS O.D.* tubing

1-1/2"	2" **
--------	-------



H-15014

MUELLER ORI-CORP Corporation Valve
Inlet: AWWA taper (MUELLER "CC") thread
Outlet: F.I.P. thread

1-1/2" ‡	2" ‡
----------	------



H-15015

MUELLER ORI-CORP Corporation Valve
Inlet: AWWA I.P. thread
Outlet: F.I.P. thread

1-1/2" ‡	2" ‡
----------	------



H-9968

MUELLER ORI-CORP Corporation Valve
Inlet: AWWA taper (MUELLER "CC") thread
Outlet: M.I.P. thread

1-1/2"	2"
--------	----



H-9969

MUELLER ORI-CORP Corporation Valve
Inlet: AWWA I.P. thread
Outlet: M.I.P. thread

1-1/2"	2" **
--------	-------

*See charts on pages 5.12-5.16 for tubing and pipe that may be used on these connections.

** For use with Service Saddle only—cannot be machine inserted.

‡ Requires minimum ordering quantity. Contact MUELLER Customer Service Center for minimum order requirements and availability.

NOTE: Sizes shown above represent nominal size of inlet and outlet connections.

MUELLER® Corporation Valves are manufactured and tested in accordance with ANSI/AWWA C800.

5.8



Rev. 9-09 Shaded area indicates changes

1/2" - 1" GROUND KEY DESIGN CORPORATION VALVES

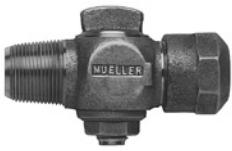

H-15008

Ground Key Corporation Valve
Inlet: AWWA taper (MUELLER "CC") thread
Outlet: MUELLER® 110® Conductive Compression Connection for CTS O.D.* tubing

1/2"‡	5/8"	3/4"	3/4"x1"	1"	1-1/2"	2"
-------	------	------	---------	----	--------	----



H-15028

Ground Key Corporation Valve
Inlet: AWWA I.P. thread
Outlet: MUELLER 110 Conductive Compression Connection for CTS O.D.* tubing

1/2"	3/4"	1"	1-1/2"	2"
------	------	----	--------	----



H-15031

Ground Key Corporation Valve
Inlet: AWWA taper (MUELLER "CC") thread
Outlet: MUELLER 110 Conductive Compression Connection for CTS O.D. tubing eighth bend connection

3/4"	1"
------	----



H-15009

Ground Key Corporation Valve
Inlet: AWWA taper (MUELLER "CC") thread
Outlet: MUELLER 110 Compression Connection for IPS PE* pipe

3/4"	1"
------	----



H-15030

Ground Key Corporation Valve
Inlet: AWWA taper (MUELLER "CC") thread
Outlet: MUELLER 110 Conductive Compression Connection for CTS O.D. tubing quarter bend connection

3/4"	1"
------	----



H-15029

Ground Key Corporation Valve
Inlet: AWWA I.P. thread
Outlet: MUELLER 110 Compression Connection for IPS PE* pipe

3/4"	1"
------	----



P-15008

Ground Key Corporation Valve
Inlet: AWWA taper (MUELLER "CC") thread
Outlet: MUELLER® Pack Joint Connection for CTS O.D.* tubing

3/4	3/4"x1"	1"
-----	---------	----



P-15028

Ground Key Corporation Valve
Inlet: AWWA I.P. thread
Outlet: MUELLER Pack Joint Connection for CTS O.D.* tubing

3/4	1"
-----	----

*See charts on pages 5.12-5.16 for tubing and pipe that may be used on these connections.

‡ Requires minimum ordering quantity. Contact MUELLER Customer Service Center for minimum order requirements and availability.

NOTE: Sizes shown above represent nominal size of inlet and outlet connections. When two sizes are given, the first is size of inlet and the second is size of outlet.

1/2" - 2" GROUND KEY DESIGN CORPORATION VALVES



H-15006

Ground Key Corporation Valve
Inlet: AWWA taper (MUELLER "CC") thread
Outlet: MUELLER® INSTA-TITE® Connection for CTS PE tubing*

3/4"	3/4" x 1" ‡	1"
------	-------------	----



H-15024

Ground Key Corporation Valve
Inlet: AWWA I.P. thread
Outlet: MUELLER® INSTA-TITE® Connection for CTS PE tubing*

3/4"	1"
------	----



H-15005

Ground Key Corporation Valve
Inlet: AWWA taper (MUELLER "CC") thread
Outlet: MUELLER INSTA-TITE Connection for IPS PE pipe*

3/4"	3/4" x 1" ‡	1"
------	-------------	----

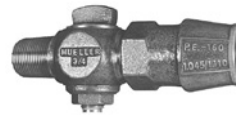

H-15026

Ground Key Corporation Valve
Inlet: AWWA I.P. thread
Outlet: MUELLER INSTA-TITE Connection for IPS PE pipe*

3/4"	1"
------	----



H-15000

Ground Key Corporation Valve
Inlet: AWWA taper (MUELLER "CC") thread
Outlet: Copper flare straight connection

5/8"	1/2" ‡	5/8" x 3/4"	3/4"	3/4" x 1"	1"
1" x 1-1/4" ‡	1-1/4"	1-1/2"	1-1/2" x 2"	2"	



H-15025

Ground Key Corporation Valve
Inlet: AWWA I.P. thread
Outlet: Copper flare straight connection

1/2"	3/4"	1"	1-1/4"	1-1/2"	2"
------	------	----	--------	--------	----



H-15010

Ground Key Corporation Valve
Inlet: AWWA taper (MUELLER "CC") thread
Outlet: Copper flare eighth bend connection

3/4"	1"	1-1/2"	2"
------	----	--------	----



H-15035

Ground Key Corporation Valve
Inlet: AWWA I.P. thread
Outlet: Copper flare eighth bend connection

3/4" ‡	1" ‡	1-1/2"	2"
--------	------	--------	----



H-15020

Ground Key Corporation Valve
Inlet: AWWA taper (MUELLER "CC") thread
Outlet: Copper flare quarter bend connection
 Ground Key Corporation Valve

5/8" x 3/4"	3/4"	3/4" x 1"	1"	1-1/2"	2"
-------------	------	-----------	----	--------	----



H-15045

Inlet: AWWA I.P. thread
Outlet: Copper flare quarter bend connection
 Ground Key Corporation Valve

3/4" ‡	1"	1-1/2"	2"
--------	----	--------	----

‡ Requires minimum ordering quantity. Contact MUELLER Customer Service Center for minimum order requirements and availability.
 NOTE: Sizes shown above represent nominal size of inlet and outlet connections. When two sizes are given, the first is size of inlet and the second is size of outlet.

1/2" - 2" GROUND KEY DESIGN CORPORATION VALVES



Inlet: AWWA taper (MUELLER "CC") thread
Outlet: F.I.P. thread
 Ground Key Corporation Valve

H-10045

1/2"	3/4"	1"	1-1/4"	1-1/2"	2"
------	------	----	--------	--------	----



Inlet: AWWA I.P. thread
Outlet: F.I.P. thread
 Ground Key Corporation Valve

H-10046

1/2"	3/4"	1"	1-1/4"‡	1-1/2"	2"
------	------	----	---------	--------	----



Ground Key Corporation Valve
Inlet: AWWA I.P. thread
Outlet: I.P. thread copper flare connection - this connection thread is one size larger than the copper tubing to be flared

H-15027

3/4"					
------	--	--	--	--	--



Inlet: AWWA taper (MUELLER "CC") thread
Outlet: I.P. thread copper flare connection - this connection thread is one size larger than the copper tubing to be flared
 *See charts on pages 5.12-5.16 for tubing and pipe that may be used on these connections.

H-15002

3/4"		1"			
------	--	----	--	--	--



Ground Key Corporation Valve
Inlet: AWWA taper (MUELLER "CC") thread
Outlet: M.I.P. thread

H-996

3/4"	1"	1-1/2"‡	2"
------	----	---------	----



Ground Key Corporation Valve
Inlet: AWWA I.P. thread
Outlet: M.I.P. thread

H-10013

1/2"	3/4"	1"	1-1/4"	1-1/2"	2"
------	------	----	--------	--------	----



Ground Key Corporation Valve
Inlet: AWWA taper (MUELLER "CC") thread
Outlet: Increasing I.P. thread (outlet is one size larger than inlet)

H-10003

1/2"	5/8" (3/4" outlet)	3/4"	1"	1-1/4"	1-1/2"	2"
------	--------------------	------	----	--------	--------	----



Ground Key Corporation Valve
Inlet: AWWA I.P. thread
Outlet: Increasing I.P. thread (outlet is one size larger than inlet)

H-9979

1/2" (3/4" outlet)	5/8" (3/4" outlet)	3/4"	1"	1-1/2"	2"
--------------------	--------------------	------	----	--------	----



Ground Key Corporation Valve
Inlet: AWWA taper (MUELLER "CC") thread
Outlet: MUELLER Coupling thread

H-9971

5/8"	3/4"	1"
------	------	----



Ground Key Corporation Valve
Inlet: AWWA I.P. thread
Outlet: MUELLER Coupling thread

H-9976

3/4"	1"
------	----

‡ Requires minimum ordering quantity. Contact MUELLER Customer Service Center for minimum order requirements and availability.

NOTE: Sizes shown above represent nominal size of inlet and outlet connections.

1/2" - 2" GROUND KEY DESIGN CORPORATION VALVES

Mueller Co.

5.11

Shaded area indicates changes Rev. 8-04



H-9991

Ground Key Corporation Valve
Inlet: AWWA taper (MUELLER "CC") thread
Outlet: MUELLER Coupling thread 1-1/64" I.D. thru valve - for use with pito tube



See page 5.14 for installation tools



H-9995

Ground Key Corporation Valve
Inlet: AWWA I.P. thread
Outlet: MUELLER Coupling thread (with coupling nut and leather washer) 1-1/64" I.D. thru valve - for use with pito tube



See page 5.14 for installation tools



H-9992

Ground Key Corporation Valve
Inlet: AWWA taper (MEULLER "CC") thread
Outlet: Inceasing I.P. thread (outlet is one size larger than inlet) 1-1/32" I.D. thru valve - for use with pito tube



See page 5.14 for installation tools



H-10012

Ground Key Corporation Valve
Inlet: Standard I.P. thread**
Outlet: M.I.P. thread

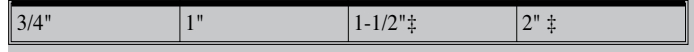

** For use with Service Saddle only — cannot be machine inserted.

‡ Requires minimum ordering quantity. Contact MUELLER Customer Service Center for minimum order requirements and availability.

NOTE: Sizes shown above represent nominal size of inlet and outlet connections.

Rev. 3-12 Shaded area indicates changes

MUELLER Drilling and Tapping Machine equipment required to install corporation valves having MUELLER 110® Compression Connection outlet

Valve size (nominal) (If two numbers: Inlet x Outlet)	1/2"		3/4"		3/4" x 1"		1"		1-1/2"	2"
	CTS	CTS	IPS PE	CTS	IPS PE	CTS	IPS PE	CTS	CTS	
Combined drill and tap size—see section 1 for part numbers	1/2"	3/4"		3/4"		1"		1-1/2"	2"	
B-101/B-100 inserting tool	680598	680600	680688	680601	680689	680601	680689	-	-	
A-3 inserting tool	-	-	-	-	-	680601	680689	680421	680422	
Maximum allowable size drill or shell cutter - see section 2 for part numbers	AWWA I.P.	7/16"	11/16"	11/16"	11/16"	11/16"	7/8"	7/8"	1-7/16"	1-3/4" *
	CC (AWWA taper)	7/16"	11/16"	11/16"	11/16"	11/16"	15/16"	15/16"	1-7/16"	1-15/16" *
Mega-Cut™/E-5 machine adapter nipple	63796	52019	508919	36750	508920	36750	508920	501949	508199	
D-5 machine adapter nipple	37900	37902	508917	37903	508918	37903	508918	507644	507645	
Tru-Cut/PL-2 machine adapter nipple for use on 1.125" max. wall PVC	-	507632	509050	507633	509051	507633	509051	-	-	

*Ball and ORI-CORP® Corporation valves IP and CC inlet: 1-7/8" maximum.

Tubeing, pipe and liners used with MUELLER 110 Compression Connection

Nominal size of connection	Material*	Tubeing or pipe O.D. range - inches	Tubeing or pipe wall thickness range - inches	Tubeing or pipe I.D. range - inches	Liner part number
1/2" CTS	Type "K" copper	0.622 - 0.628	0.045 - 0.053	-	-
3/4" CTS	Type "K" copper	0.872 - 0.878	0.061 - 0.069	-	-
	Polyethylene	0.871 - 0.879	0.097 - 0.107	0.657 - 0.685	504281
1" CTS	Type "K" copper	1.121 - 1.129	0.061 - 0.069	-	-
	Polyethylene	1.120 - 1.130	0.125 - 0.137	0.846 - 0.880	504385
1-1/4" CTS	Type "K" copper	1.371 - 1.379	0.060 - 0.070	-	-
	Polyethylene	1.370 - 1.380	0.153 - 0.168	1.034 - 1.074	505142
1-1/2" CTS	Type "K" copper	1.621 - 1.630	0.067 - 0.077	-	-
	Polyethylene	1.619 - 1.631	0.181 - 0.199	1.221 - 1.269	506139
2" CTS	Type "K" copper	2.120 - 2.130	0.076 - 0.090	-	-
	Polyethylene	2.119 - 2.131	0.236 - 0.260	1.599 - 1.659	506141
3/4" IPS	Polyethylene	1.045 - 1.110	0.118 - 0.138	0.809 - 0.834	505141
	3/4" Sch. 40 PVC	1.046 - 1.054	0.113 - 0.133	0.780 - 0.828	509759
	3/4" Sch. 80 PVC	1.046 - 1.054	0.154 - 0.174	0.698 - 0.746	509760
1" IPS	Polyethylene	1.329 - 1.399	0.150 - 0.170	1.029 - 1.059	505142
	1" Sch. 40 PVC	1.310-1.320	0.133-0.153	-	-
	1" Sch. 80 PVC	1.310-1.320	0.179-0.200	-	-

*Type "K" soft copper tubeing per ASTM B88; CTS polyethylene (PE) per ASTM D-2737 - SDR-9; IPS polyethylene (PE) per ASTM D-2239 - PE SDR-7; IPS polyvinylchloride (PVC) per ASTM D1785



Size	Kit	Gasket part number†	Connection nut
1/2" CTS		681516	147542
3/4" CTS	682600	581949	507831
1" CTS	682601	581951	507835
1-1/2" CTS		581955	507847
2" CTS		581957	507851
3/4" IPS PE		89599	508826
1" IPS PE		89788	508827

†Gasket and gripper band assembly



Corporation Valve Wrench



For operating up to and including 1" corporation valves.

MUELLER® Drilling and Tapping Machine equipment required to install corporation valves having MUELLER INSTA-TITE Connection outlets

Valve size (nominal) (If two numbers: Inlet x Outlet)	3/4" CTS PE or IPS PE	3/4" x 1" CTS PE or IPS PE	1" CTS PE or IPS PE
Combined drill and tap size—see section 1 for part numbers	3/4"	3/4"	1"
B-101/B-100 inserting tool	680600	680601	680601
A-3 inserting tool	-	-	680601
Maximum allowable size drill or shell cutter - see section 2 for part numbers	AWWA I.P.	11/16"	11/16"
	CC (AWWA taper)	11/16"	11/16"
Mega-Cut™/E-5 machine adapter nipple	52019	36750	36750
D-5 machine adapter nipple	37902	37903	37903
Tru-Cut/PL-2 machine adapter nipple for use on 1.125" max. wall PVC	507632	507633	507633

Polyethylene PE tubing and pipe used with MUELLER INSTA-TITE Connections

Nominal size of connection	Material	Tubing or pipe O.D. range - inches	Tubing or pipe wall thickness range - inches	Tubing or pipe I.D. range - inches
3/4" CTS PE	Polyethylene PE	0.871 - 0.879	0.097 - 0.107	0.657 - 0.685
1" CTS PE	Polyethylene PE	1.120 - 1.130	0.125 - 0.137	0.846 - 0.880
3/4" IPS PE	Polyethylene PE	1.045 - 1.110	0.118 - 0.138	0.809 - 0.834
1" IPS PE	Polyethylene PE	1.329 - 1.399	0.150 - 0.170	1.029 - 1.059

CTS polyethylene (PE) per ASTM D-2737 - SDR-9
IPS polyethylene (PE) per ASTM D-2239 - PE SIDR-7

MUELLER INSTA-TITE Connection replacement parts

Size	Gripper ring part number†	O-Ring part number
3/4" CTS PE	506325	506324
1" CTS PE	506327	506326
3/4" IPS PE	505885	505883
1" IPS PE	505886	505884

†Gasket and gripper band assembly



Corporation Valve Wrench

For operating up to and including 1" corporation stops and valves.



H-10048

MUELLER INSTA-TITE Connection optional equipment Pipe beveling tool

To assure proper installation, the end of the pipe or tubing must be properly beveled before it is inserted into the MUELLER INSTA-TITE Connection. MUELLER CO. offers special beveling tool for CTS PE tubing and IPS PE pipe.



PART NUMBER: **H-18015** for 3/4" and 1" CTS tubing
PART NUMBER: **H-18017** for 3/4" and 1" IPS pipe

Pipe removal tool

Pipe or tubing may be removed from the MUELLER INSTA-TITE Connection using special removal tools. Use one tool for 3/4" size connection and two tools for 1" size.



PART NUMBER : **506336**

MUELLER® Drilling and Tapping Machine equipment required to install corporation having MUELLER Pack Joint Connection outlets

Valve size (nominal) (If two numbers: Inlet x Outlet)	3/4" CTS	IPS PE & PVC	3/4"x1" CTS	IPS PE & PVC	1" CTS	IPS PE & PVC	1-1/2" CTS	IPS PE	IPS PVC	2" CTS	IPS PE	IPS PVC
Combined drill and tap size—see section 1 for part numbers	3/4"		3/4"		1"		1-1/2"			2"		
B-101/B-100 inserting tool	680600		680601		680601		-			-		
A-3 inserting tool	-		-		680601		680421			680422		
Maximum allowable size drill or shell cutter - see section 2 for part numbers	AWWA I.P.	11/16"	11/16"		7/8"		1-7/16"	1-7/16"		1-3/4"*	1-3/4"*	
	CC (AWWA taper)	11/16"	11/16"		15/16"		1-7/16"	1-7/16"		1-15/16"*	1-15/16"*	
Mega-Cut™/E-5 machine adapter nipple	52019	508919	36750	682256	36750	682256	501949	508199**	682257	508199	682258	682258
D-5 machine adapter nipple	37902	508917	37903	682259	37903	682259	507644	507645**	682033	507645	682034	682034
Tru-Cut/PL-2 machine adapter nipple for use on 1.125" max. wall PVC	507632	509050	507633		507633	682290	-			-		

* Ball and ORI-CORP® Corporation valves IP and CC inlet: 1-7/8" maximum. ** Adapter is also used on 2" CTS 110

Tubeing, pipe and liners used with MUELLER Pack Joint Connection

Nominal size of connection	Material*	Tubeing or pipe O.D. range - inches	Tubeing or pipe wall thickness range - inches	Tubeing or pipe I.D. range - inches	Liner part number
3/4" CTS	Type "K" copper	0.872 - 0.878	0.061 - 0.069	-	-
	Polyethylene	0.871 - 0.879	0.097 - 0.107	0.657 - 0.685	528704
1" CTS	Type "K" copper	1.121 - 1.129	0.061 - 0.069	-	-
	Polyethylene	1.120 - 1.130	0.125 - 0.137	0.846 - 0.880	528705
1-1/2" CTS	Type "K" copper	1.621 - 1.630	0.067 - 0.077	-	-
	Polyethylene	1.619 - 1.631	0.181 - 0.199	1.221 - 1.269	528706
2" CTS	Type "K" copper	2.120 - 2.130	0.076 - 0.090	-	-
	Polyethylene	2.119 - 2.131	0.236 - 0.260	1.599 - 1.659	528707
3/4" IPS	Polyethylene	1.045 - 1.110	0.118 - 0.138	0.809 - 0.834	505141
	3/4" Sch. 40 PVC	1.046 - 1.054	0.113 - 0.133	0.780 - 0.828	509759
	3/4" Sch. 80 PVC	1.046 - 1.054	0.154 - 0.174	0.698 - 0.746	509760
1" IPS	Polyethylene	1.329 - 1.399	0.150 - 0.170	1.029 - 1.059	505142
	1" Sch. 40 PVC	1.310 - 1.320	0.133 - 0.153	-	-
	1" Sch. 80 PVC	1.310 - 1.320	0.179 - 0.200	-	-
1-1/4" IPS	Polyethylene	1.754 - 1.832	0.197 - 0.221	1.360 - 1.390	312787
1-1/2" IPS	Polyethylene	2.05 - 2.141	0.230 - 0.258	1.590 - 1.625	529116
	1-1/2" Sch. 40 PVC	1.894 - 1.906	0.145 - 0.165	-	-
	1-1/2" Sch. 80 PVC	1.894 - 1.906	0.200 - 0.224	-	-
2" IPS	Polyethylene	2.637 - 2.742	0.295 - 0.330	2.047 - 2.082	529117
	2" Sch. 40 PVC	2.369 - 2.381	0.154 - 0.174	-	-
	2" Sch. 80 PVC	2.369 - 2.381	0.218 - 0.244	-	-

*Type "K" soft copper tubeing per ASTM B88; CTS polyethylene (PE) per ASTM D-2737 - SDR-9; IPS polyethylene (PE) per ASTM D-2239 - PE SIDR-7 ;IPS polyvinylchloride (PVC) per ASTM D1785



Liner

MUELLER Pack Joint Connection Kit

Size	Connection kit
3/4" CTS	681921
1" CTS	681922
1-1/2" CTS	681923
2" CTS	681924



Connection Kit
(includes Pack Joint, Gasket and Washer)

Corporation Valve Wrench

For operating up to and including 1" corporation valves.



H-10048

CORPORATION VALVE COPPER FLARE TOOLS & MISCELLANEOUS **Mueller Co.** 5.15

Shaded area indicates changes Rev. 9-09

MUELLER® Drilling and Tapping Machine equipment required to install corporation valves having copper flare connection outlet

Valve size (nominal) (If two numbers: Inlet x Outlet)	1/2"	1/2"x3/4"	5/8"x3/4"	3/4"	3/4"x1"	1"	1-1/4"	1-1/2"	2"	
Combined drill and tap size - see section 1 for part numbers	1/2"	1/2"	5/8"	3/4"	3/4"	1"	1-1/4"	1-1/2"	2"	
B-101/B-100 inserting tool	680598	680600	680600	680600	680601	680601	-	-	-	
A-3 inserting tool	-	-	-	-	-	680601	680602	88640	88641	
Maximum allowable size drill or shell cutter - see section 2 for part numbers	AWWA I.P.	7/16"	7/16"	9/16"	11/16"	11/16"	7/8"	1-1/8"	1-7/16"	1-3/4"*
	CC (AWWA taper)	7/16"	7/16"	9/16"	11/16"	11/16"	15/16"	1-3/16"	1-7/16"	1-15/16"*
Mega-Cut™/E-5 machine adapter nipple	63796	52019	52019	52019	36750	36750	682256	501947	508201	
D-5 machine adapter nipple	37900	37902	37902	37902	37903	37903	682259	37905	37906	
Tru-Cut/PL-2 machine adapter nipple for use on 1.125" max. wall PVC	-	-	-	507632	507633	507633	-	-	-	

* Ball and ORI-CORP® Corporation valves IP and CC inlet: 1-7/8" maximum.

I.P. thread copper flare connection optional equipment

I.P. thread copper flare nut
This connection thread is one size larger than the copper tubing to be flared.
CATALOG NUMBER: **H-15432**



3/4"	1"
------	----

Solid copper disc
Used with regular copper flare nut to shut off line.
CATALOG NUMBER: **H-15535**



1/2"	3/4"	1"	1-1/4"	1-1/2"	2"
------	------	----	--------	--------	----

Brass cap
Fits on copper flare spud to cap off line.
CATALOG NUMBER: **H-15540**



3/4"	1"	1-1/2"	2"
------	----	--------	----

Flaring Tool



Used to make 45° flare on type "K" copper tubing.
CATALOG NUMBER: **H-18000**

1/2"	3/4"	1"	1-1/4"	1-1/2"	2"
------	------	----	--------	--------	----

Drilled Flaring Tool



Used to make 45° flare on type "K" copper tubing without shutting off water—drilled to exhaust water at right angle to tubing.
CATALOG NUMBER: **H-18005**

3/4"	1"
------	----

Reamer



Used to ream the inside of type "K" copper tubing to remove burrs prior to flaring.
CATALOG NUMBER: **H-18010**

1/2"	3/4"	1"
------	------	----

Brass Hammer



Solid brass head with 10" wooden handle.
Weight 2- 3/4 lb.
CATALOG NUMBER: **H-18025**

Compression to Flare Push-in-Bushing



CATALOG NUMBER: **682332**

3/4"	1"
------	----

Corporation Valve Wrench

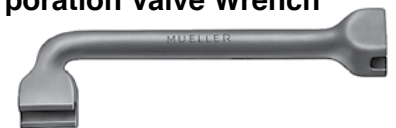

For operating up to and including 1" corporation and valves.
CATALOG NUMBER: **H-10048**

Note: When using any striking tool, safety eye protection must be worn. Inspect hammer and tools for any damage after each use and repair or replace if mushrooming or chipping evident.

MUELLER® Drilling and Tapping Machine equipment required to install corporation valves having female I.P. thread outlet

Valve size (nominal)		1/2"	3/4"	1"	1-1/4"	1-1/2"	2"
Combined drill and tap size—see section 1 for part numbers		1/2"	3/4"	1"	1-1/4"	1-1/2"	2"
B-101/B-100 inserting tool		680630	680631	680632	-	-	-
A-3 inserting tool		-	-	680632	61212	61213	61214
Maximum allowable size drill or shell cutter — see section 2 for part numbers	AWWA I.P.	7/16"	11/16"	7/8"	1-1/8"	1-7/16"	1-3/4" *
	CC (AWWA taper)	7/16"	11/16"	15/16"	1-1/8"	1-7/16"	1-15/16" *
Mega-Cut™/E-5 machine adapter nipple		36967	36920	36918	36733	503435	78907
D-5 machine adapter nipple		-	33556	36323	36195	36196	36188
Tru-Cut/PL-2 machine adapter nipple for use on 1.125" max. wall PVC		-	-	-	-	-	-

MUELLER Drilling and Tapping Machine equipment required to install corporation valves having male I.P. thread outlet

Valve size (nominal)		3/4"	1"	1-1/4"	1-1/2"	2"
Combined drill and tap size—see section 1 for part numbers		3/4"	1"	1-1/4"	1-1/2"	2"
B-101/B-100 inserting tool		680595	680596	-	-	-
A-3 inserting tool		-	680596	680597	83065	83066
Maximum allowable size drill or shell cutter — see section 2 for part numbers	AWWA I.P.	11/16"	7/8"	1-1/8"	1-7/16"	1-3/4" *
	CC (AWWA taper)	11/16"	15/16"	-	1-7/16"	1-15/16" *
Mega-Cut™/E-5 machine adapter nipple		36919	36917	36928	501948	508200
D-5 machine adapter nipple		36910	36911	36912	36913	36525
Tru-Cut/PL-2 machine adapter nipple for use with 1.125" maximum wall PVC		507630	507631	-	-	-

MUELLER Drilling and Tapping Machine equipment required to install corporation valves having increase I.P. thread outlet

Valve size (nominal)		1/2"	5/8"	3/4"	1"	1-1/4"	1-1/2"	2"
Combined drill and tap size—see section 1 for part numbers		1/2"	5/8"	3/4"	1"	1-1/4"	1-1/2"	2"
B-101/B-100 inserting tool		680595	680595	680596	680597	-	-	-
A-3 inserting tool		-	-	-	680597	83065	83066	83157
Maximum allowable size drill or shell cutter — see section 2 for part numbers	AWWA I.P.	7/16"	9/16"	3/4"	15/16"	-	1-7/16"	1-3/4"
	CC (AWWA taper)	7/16"	9/16"	11/16"	15/16"	1"	1-7/16"	1-15/16"
Mega-Cut™/E-5 machine adapter nipple		36919	36919	36917	36928	501948	508200	-
D-5 machine adapter nipple		-	-	36911	36912	36913	36525	36526

MUELLER Drilling and Tapping Machine equipment required to install corporation valves having MUELLER coupling thread outlet

Valve size (nominal)		1/2"	5/8"	3/4"	1"
Combined drill and tap size—see section 1 for part numbers		1/2"	5/8"	3/4"	1"
B-101/B-100 inserting tool		680609	680610	680611	680612
A-3 inserting tool		-	-	-	680612
Maximum allowable size drill or shell cutter — see section 2 for part numbers	AWWA I.P.	7/16"	9/16"	3/4"	15/16"
	CC (AWWA taper)	-	-	11/16"	1"
Mega-Cut™/E-5 machine adapter nipple		75493	75494	75495	75496
D-5 machine adapter nipple		-	-	61165	77375

outlet

Valve size (nominal)		1-1/2"	1-3/4"	1-1/2"	1-1/2"	1-1/2"
Combined drill and tap size—see section 1 for part numbers		1"	1"	1"	3/4"	1"
B-101/B-100 inserting tool		680612	680612	680597	680603	680604
A-3 inserting tool		680612	680612	680597	-	680604
Maximum allowable size drill or shell cutter — see section 2 for part numbers	AWWA I.P.	-	-	-	11/16"	15/16"
	CC (AWWA taper)	-	-	-	11/16"	15/16"
Mega-Cut™/E-5 machine adapter nipple		-	-	-	43900	43870
D-5 machine adapter nipple		-	-	-	45380	51104

* Ball and ORI-CORP® Corporation valves IP and CC inlet: 1-7/8" maximum.