

MUELLER AquaGrip System

The MUELLER AquaGrip System includes both the compression connection and the restraint system in one convenient, quick installation package. This eliminates the need for anchor couplings, tie rods or separate gland-type restraints. The AquaGrip system is available exclusively from Mueller on Centurion Fire Hydrants and 2300 Series Resilient Wedge Valves.

- ❑ **TWO STYLES:**
DIPS fits DI, C900 PVC and DIPS PE pipe.
IPS fits PVC, IPS PE.
No special pipe end preparation, and no liner required for PE pipe (DR9-DR17)

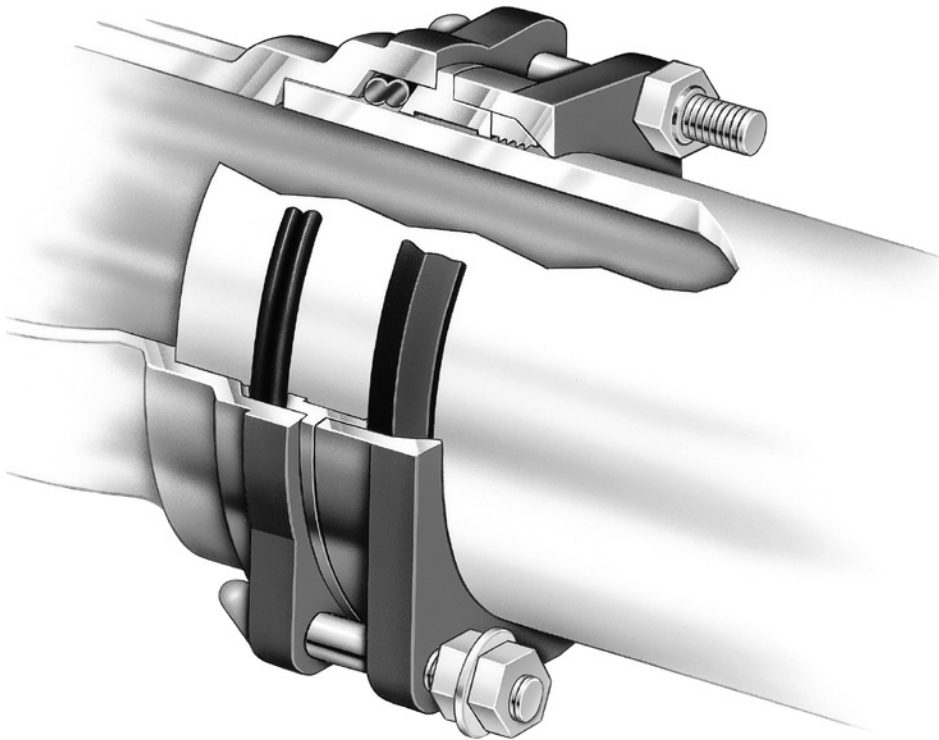

- ❑ **FULLY ASSEMBLED STAB CONNECTION** — insert the pipe and tighten the bolts. No need to change-out, add or remove parts. Nothing additional to inventory or handle in the field. No extra bolts to assemble or tighten.

- ❑ **NO POINT LOADING OF PIPE** — gripper ring encircles pipe for uniform grip without creating points of high stress in pipe wall that could contribute to pipe failure.

- ❑ **PRESSURE RESPONSIVE O-RING SEAL** — unique double O-ring uses hydrostatic pressure from inside the pipe to enhance the seal as line pressure increases.

- ❑ **VISUALLY SHOWS WHEN PROPERLY TIGHTENED** — breakaway nuts snap off using a standard wrench. No special torque requirements. Inner nut remains in place to allow future access to connection, if required. (Lower nut shown before tightening; upper one after tightening.)

- ❑ **INSTALLS IN WET CONDITIONS** — no special field conditions required, even installs under water.

MUELLER SUPER CENTURION 250™ 3-Way Fire Hydrant Features

- ❑ ANTI-FRICTION WASHER - helps assure easy turning operation for the life of the hydrant.
- ❑ OIL FILLER PLUG - permits quick check of oil level. Lets you add oil without removing bonnet.
- ❑ OIL RESERVOIR O-RING SEALS - seal oil in, water out.
- ❑ STAINLESS STEEL SAFETY STEM COUPLING - pulls free if hydrant is hit by a vehicle preventing damage to the stem and main valve. Coupling will not break into pieces that could drop into lower barrel and affect valve operation. Top of lower stem is below the top of the lower barrel so that a tire cannot depress the stem and open the main valve. Repair is easy and economical.
- ❑ SAFETY FLANGE - breaks cleanly to help prevent barrel damage, yet is strong enough to withstand normal handling. Allows economical repair, adding of extension section, rotation or changing of upper barrel without digging or water shut-off.
- ❑ BRONZE UPPER VALVE PLATE - conical design for smooth flow.
- ❑ DRAIN VALVE FACINGS - specially designed, long-life facings provide effective sealing.
- ❑ **CAST IRON CAP NUT** - retains main valve. Seats against cap nut gasket to prevent corrosion of stem threads. Locked in place by a stainless steel lock washer. Mueller HP Epoxy coated for durability.
- ❑ 250 PSIG - 3-way hydrant: 250 psig (1723 kPa) maximum working pressure, 500 psig (3447kPa)
- ❑ SHOE DESIGNED FOR MAXIMUM FLOW AND EASY CONNECTION - with its smooth transitional contours, extended neck and integral anti-rotation pads, allowing use of standard tee-head bolts. The inside of the shoe is covered with MUELLER HP™ Epoxy Coating. This thermosetting epoxy forms a tough corrosion-resistant barrier to chemicals, physical impact and electrical currents.
- ❑ HOLD-DOWN NUT - with integral weather seal. Design discourages unauthorized removal of the hold-down nut or bronze operating nut. Resilient wiper seal between hold-down nut and operating nut prevents water entry to protect operating nut from freezing. Wiper seal material is resistant to ultra-violet ray deterioration. O-ring seal provides second level of protection.
- ❑ MEETS OR EXCEEDS - all applicable requirements of ANSI/AWWA C502 Standard and UL 246 and FM 1510 specifications.
- ❑ O-RING SEALS AT BONNET, GROUND, AND SHOE FLANGES - for better leak resistance, easier maintenance.
- ❑ SEALED OIL RESERVOIR - O-ring sealed to prevent leakage. Provides positive lubrication of stem threads and bearing surfaces each time the hydrant is operated. Filled at the factory.
- ❑ FULL FLOW OPENINGS - large radius hose and pumper openings produce low friction loss.
- ❑ FIELD REPLACEABLE HOSE AND PUMPER NOZZLES - O-ring sealed. Threaded in place and retained by stainless steel locks. Nozzles are easily replaced.
- ❑ ELECTRO-GALVANIZED BOLTS AND NUTS - provide corrosion protection.
- ❑ NON-KINKING CHAINS - heavy-duty chains are securely attached to the hydrant. Special chain loop permits free turning of the cap.
- ❑ BRONZE SEAT RING - threaded into drain ring and O-ring sealed. Seat ring is easily removed or installed from above ground. Each time main valve is opened or closed, double drain valves force-flush both drain valve openings to keep them open for effective barrel drainage. Bronze drain valves are integral parts of main valve assembly.
- ❑ REVERSIBLE, COMPRESSION-TYPE MAIN VALVE - closes with pressure for positive seal. Rubber material has long service life, yet is reversible providing a convenient spare in place.

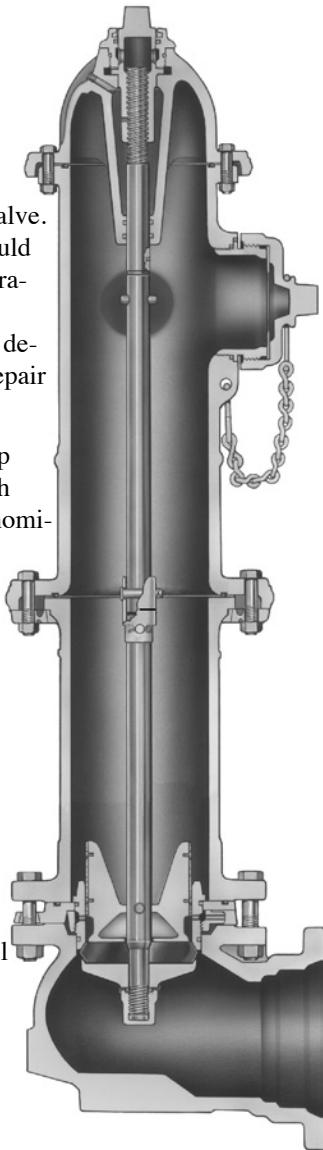

MUELLER SUPER CENTURION 250™ 3-Way Fire Hydrant Features

- ❑ ANTI-FRICTION WASHER helps assure easy turning operation for the life of the hydrant.
- ❑ OIL FILLER PLUG permits quick check of oil level. Lets you add oil without removing bonnet.
- ❑ OIL RESERVOIR O-RING SEALS seal oil in, water out.
- ❑ STAINLESS STEEL SAFETY STEM COUPLING - pulls free if hydrant is hit by a vehicle preventing damage to the stem and main valve. Coupling will not break into pieces that could drop into lower barrel and affect valve operation. Top of lower stem is below the top of the lower barrel so that a tire cannot depress the stem and open the main valve. Repair is easy and economical.
- ❑ SAFETY FLANGE - breaks cleanly to help prevent barrel damage, yet is strong enough to withstand normal handling. Allows economical repair, adding of extension section, rotation or changing of upper barrel without digging or water shut-off.
- ❑ BRONZE UPPER VALVE PLATE conical design for smooth flow.
- ❑ DRAIN VALVE FACINGS specially designed, long-life facings provide effective sealing.
- ❑ DUCTILE IRON CAP NUT retains main valve. Seats against cap nut gasket to prevent corrosion of stem threads. Locked in place by a stainless steel lock washer. Mueller HP Epoxy coated for durability.
- ❑ 250 PSIG - 3-way hydrant: 250 psig (1723 kPa) maximum working pressure, 500 psig (3447 kPa)
- ❑ SHOE DESIGNED FOR MAXIMUM FLOW AND EASY CONNECTION with its smooth transitional contours, extended neck and integral anti-rotation pads, allowing use of standard tee-head bolts. The inside of the shoe is covered with MUELLER HP® Epoxy Coating. This thermosetting epoxy forms a tough corrosion-resistant barrier to chemicals, physical impact and electrical currents.
- ❑ HOLD-DOWN NUT - with integral weather seal. Design discourages unauthorized removal of the hold-down nut or bronze operating nut. Resilient wiper seal between hold-down nut and operating nut prevents water entry to protect operating nut from freezing. Wiper seal material is resistant to ultra-violet ray deterioration. O-ring seal provides second level of protection.
- ❑ MEETS OR EXCEEDS all applicable requirements of ANSI/AWWA C502 Standard and UL 246 and FM 1510 specifications.
- ❑ O-RING SEALS AT BONNET, GROUND, AND SHOE FLANGES for better leak resistance, easier maintenance.
- ❑ SEALED OIL RESERVOIR - O-ring sealed to prevent leakage. Provides positive lubrication of stem threads and bearing surfaces each time the hydrant is operated. Filled at the factory.
- ❑ FULL FLOW OPENINGS large radius hose and pumper openings produce low friction loss.
- ❑ FIELD REPLACEABLE HOSE AND PUMPER NOZZLES - O-ring sealed. Threaded in place and retained by stainless steel locks. Nozzles are easily replaced.
- ❑ ELECTRO-GALVANIZED BOLTS AND NUTS - provide corrosion protection.
- ❑ NON-KINKING CHAINS heavy-duty chains are securely attached to the hydrant. Special chain loop permits free turning of the cap.
- ❑ BRONZE SEAT RING - threaded into drain ring and O-ring sealed. Seat ring is easily removed or installed from above ground. Each time main valve is opened or closed, double drain valves force-flush both drain valve openings to keep them open for effective barrel drainage. Bronze drain valves are integral parts of main valve assembly.
- ❑ REVERSIBLE, COMPRESSION TYPE MAIN VALVE - closes with pressure for positive seal. Rubber material has long service life, yet is reversible providing a convenient spare in place.

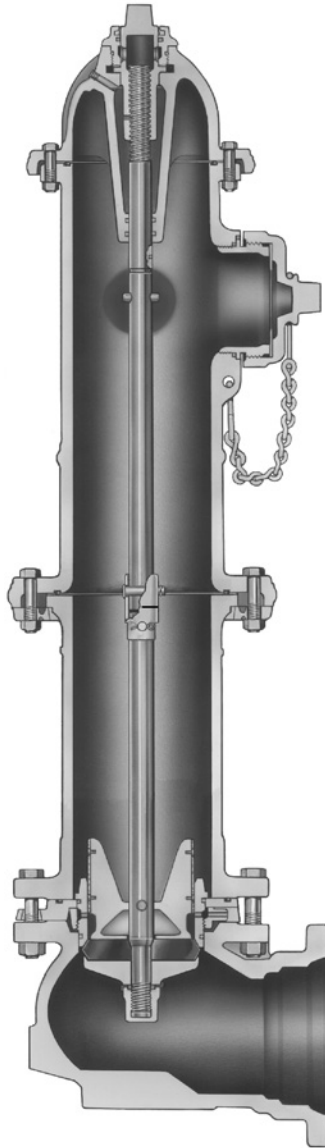

Rev. 9-09

MUELLER SUPER CENTURION 200™ 2-Way and 1-Way Fire Hydrant

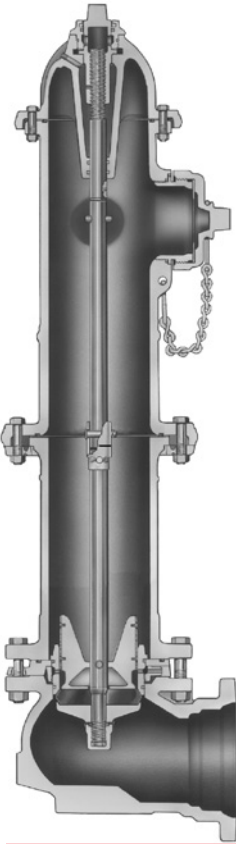

- ❑ Meets all applicable parts of ANSI/AWWA C502 Standard
- ❑ Hold-down nut with integral weather seal; designed to discourage unauthorized tampering
- ❑ Gasket seals at bonnet, ground and shoe flanges
- ❑ Dry top design with O-ring sealed oil reservoir
- ❑ Stainless steel safety stem coupling pulls free if hydrant is hit by a vehicle preventing damage to the stem and main valve
- ❑ Reversible, compression-type main valve closes with pressure for positive seal
- ❑ Low flow loss design with full flow nozzles and shoe
- ❑ Field replaceable nozzles
- ❑ Dual bronze drain ways
- ❑ 200 psig (1379 kPa) maximum working pressure, 400 psig (2758 kPa) test pressure

MUELLER MODERN CENTURION™ Fire Hydrant

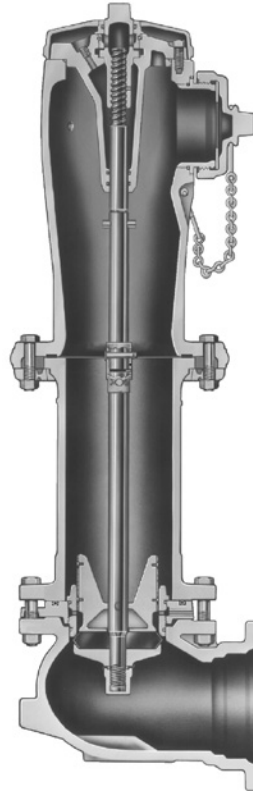

- ❑ Modern, sleek exterior design
- ❑ Meets all applicable parts of ANSI/AWWA C502 Standard
- ❑ Post type dry barrel design
- ❑ Dry top design with O-ring sealed oil reservoir
- ❑ Traffic feature
- ❑ Stainless steel safety stem coupling pulls free if hydrant is hit by a vehicle preventing damage to the stem and main valve
- ❑ Reversible, compression-type main valve closes with pressure for positive seal
- ❑ Low flow loss design with full flow nozzles and shoe
- ❑ Field replaceable nozzles
- ❑ Dual bronze drain ways
- ❑ Two way and three way designs
- ❑ 200 psig (1379 kPa) maximum working pressure, 400 psig (2758 kPa) test pressure

MUELLER CENTURION Spin-In Fire Hydrant

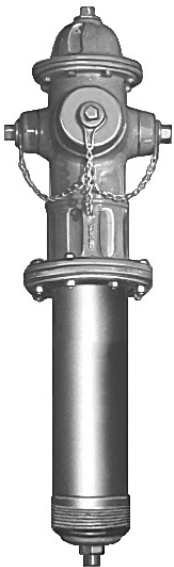

- ❑ Lower barrel threaded to fit most sizes of R.D.Wood fire hydrant shoes
- ❑ Meets all applicable parts of ANSI/AWWA C502 Standard
- ❑ Post type dry barrel design
- ❑ Dry top design with O-ring sealed oil reservoir
- ❑ Traffic feature
- ❑ Reversible, compression-type main valve closes with pressure for positive seal
- ❑ Low flow loss design with full flow nozzles and shoe
- ❑ Field replaceable nozzles
- ❑ Dual bronze drain ways
- ❑ Two way and three way design
- ❑ 200 psig (1379 kPa) maximum working pressure, 400 psig (2758 kPa) test pressure

MUELLER 2-1/8" Post and Flush Type Fire Hydrants



- ❑ 2-1/8" main valve opening
- ❑ Meets all applicable parts of ANSI/AWWA C502 Standard
- ❑ Dry barrel design
- ❑ Used for blow offs, sampling, irrigation, golf course watering, private estates, etc.
- ❑ Compression type main valve closes with pressure
- ❑ Bronze drain
- ❑ Flush type has a cast iron box with lid
- ❑ 150 psig (1034 kPa) maximum working pressure 300 psig (2068 kPa) test pressure

MUELLER® O.E.M. FIRE HYDRANT REPAIR PARTS AND REPAIR KITS

MUELLER CO. considers a fire hydrant to be a critical piece of emergency equipment used to preserve lives and property. For this reason all Mueller Fire Hydrants are designed, built and tested to assure high performance and dependability.

Each component part of a MUELLER Fire Hydrant is specially designed to assure proper and reliable operation. Attention to detail doesn't stop once the part is designed. Quality control tests are made on all component parts to assure dimensional and material integrity are maintained. Every MUELLER Fire Hydrant is pressure tested and operated before it leaves our plant to assure it meets our high quality standards.

MUELLER CO. is confident it produces one of the most reliable fire hydrants available and backs this claim with a **10 YEAR LIMITED WARRANTY ON PARTS AND WORKMANSHIP** for the MUELLER Super CENTURION® Fire Hydrant. The claim of outstanding performance and reliability is proven by the fact that almost half of all the fire hydrants sold in the United States today are manufactured by MUELLER CO.

A fire hydrant is exposed to the elements on a daily basis and over a period of time repairs may eventually become necessary. MUELLER CO. offers repair kits that have the same parts as are used in our regular production hydrants. When you use genuine MUELLER replacement parts you are assured the part matches the manufacturer's original equipment specifications with regard to dimensions, materials and performance. Only genuine MUELLER parts are marked with the MUELLER name.



Typical bonnet repair kit



Typical safety flange repair kit



Typical shoe repair kit



Typical main valve repair kit

9.6



MUELLER® SUPER CENTURION® FIRE HYDRANT WITH AQUAGRIP™ SYSTEM

Rev. 8-04 Shaded area indicates changes

- ❑ **Super Centurion 250™**
A-421 4-1/2" main valve opening three way (two hose nozzles and one pumper nozzle)
A-423 5-1/4" main valve opening three way (two hose nozzles and one pumper nozzle)
- ❑ 10 year limited warranty on material and workmanship
- ❑ Meets all applicable parts of ANSI/AWWA C502 Standard
- ❑ Post type dry barrel design
- ❑ Dry top design with O-ring sealed oil reservoir
- ❑ Traffic feature with stainless steel safety stem coupling
- ❑ Compression-type main valve closes with pressure for positive seal; it is made of rubber and is conveniently reversible providing a spare for long service life (Patent Pending)
- ❑ Operating nut available in wide variety of shapes and sizes – open left or right
- ❑ Field replaceable hose and pumper nozzles
- ❑ Hose and pumper nozzles have large radius, full flow openings for low friction loss
- ❑ Contoured shoe is designed for full flow
- ❑ Dual bronze drain valves provide effective barrel drainage
- ❑ 250 psig (1723 kPa) maximum working pressure, 500 psig (3447 kPa) static test pressure for 3-way hydrants;
200 psig (1379 kPa) maximum working pressure, 400 psig (2758 kPa) static test pressure for 2-way and 1-way hydrants

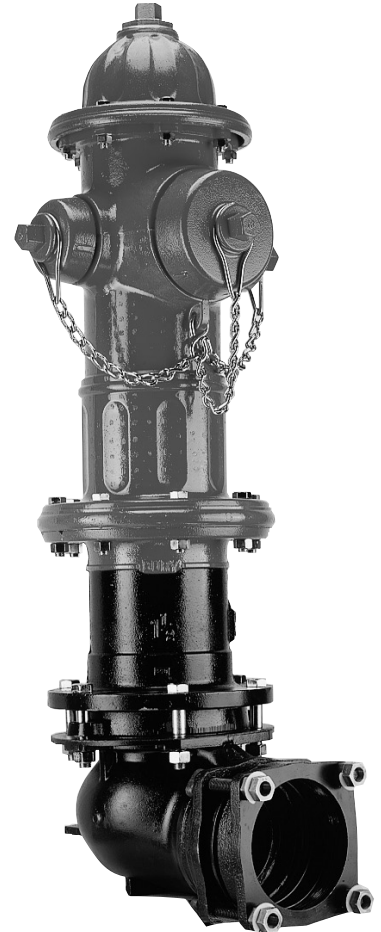

Dimensions

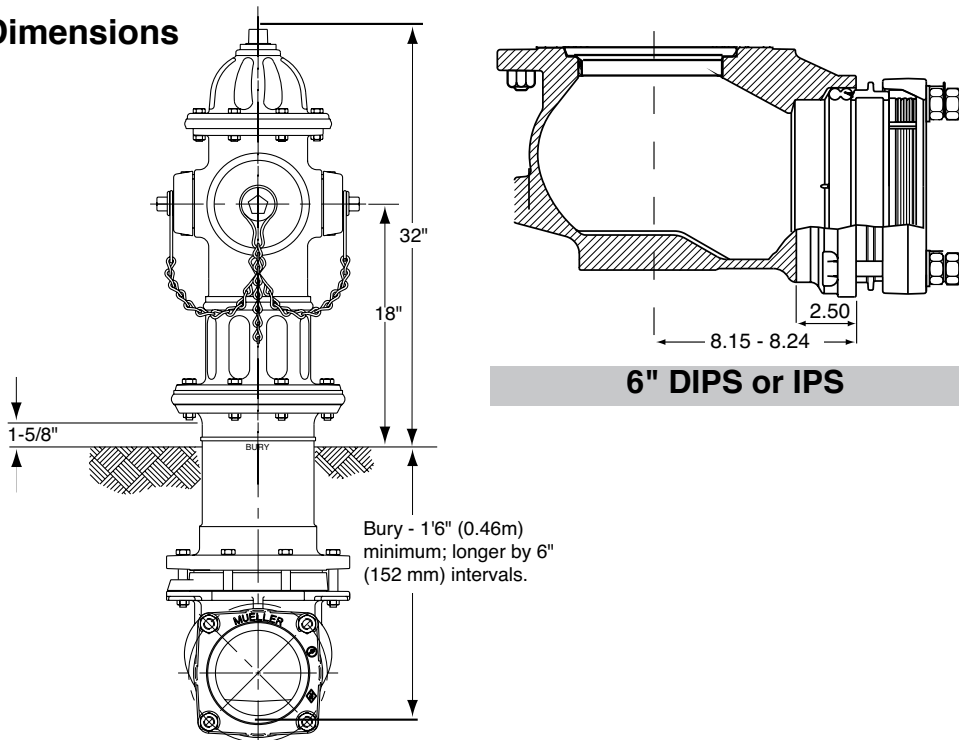

SEE PAGE 9.28 FOR ORDERING INSTRUCTIONS

MUELLER® SUPER CENTURION® FIRE HYDRANT WITH AQUAGRIP™ SYSTEM

Mueller Co.

9.7

Shaded area indicates changes Rev. 9-09

MUELLER Super Centurion Fire Hydrant Parts

Cat. part #	Description	Material	Material standard
A-1	Operating Nut	Bronze	ASTM B584
A-3	Hold Down Nut O-ring	Rubber	ASTM D2000 BUNA N
A-5	Bonnet O-ring	Rubber	ASTM D2000 BUNA N
A-6	Anti-friction Washer	Celcon	
A-7	Oil Plug	Brass	ASTM B16
A-8	Bonnet	Cast Iron	ASTM A126 CL.B
A-9	Bonnet Bolt and Nut	Steel	ASTM A307 Plated
A-10	Bonnet O-ring	Rubber	ASTM D2000 BUNA N
A-11	Upper Stem	Steel	ASTM A576 GR.B
A-12	Stem O-ring	Rubber	ASTM D2000 BUNA N
A-13	Nozzle Lock	Stainless Steel	ASTM A276
A-14	Pumper Nozzle	Bronze	ASTM B584
A-15	Pumper Nozzle Gasket	Rubber	ASTM D2000 Neoprene
A-16	Pumper Nozzle O-ring	Rubber	ASTM D2000 BUNA N
A-17	Pumper Nozzle Cap	Cast Iron	ASTM A126 CL.B
A-18	Hose Nozzle	Bronze	ASTM B584
A-19	Hose Nozzle Gasket	Rubber	ASTM D2000 Neoprene
A-20	Hose Nozzle O-ring	Rubber	ASTM D2000 BUNA N
A-21	Hose Nozzle Cap	Cast Iron	ASTM A126 CL.B
A-22	Cap Chain	Steel	Plated
A-23	Chain Ring	Steel	Plated
A-24	Upper Barrel Less Nozzles	Cast Iron	ASTM A126 CL.B
A-25	Safety Coupling	Stainless Steel	ASTM A890
A-26	Safety Flange Bolt and Nut	Steel	ASTM A307 Plated
A-27	Safety Flange O-ring	Rubber	Cellulose
A-28	Safety Flange	Cast Iron	ASTM A126 CL.B
A-29	Cotter Pin	Stainless Steel	ASTM A276
A-30	Clevis Pin	Stainless Steel	ASTM A276
A-31	Lower Stem	Steel	ASTM A576 GR.B
A-32	Lower Barrel	Cast Iron	ASTM A126 CL.B
A-33	Stem Pin	Stainless Steel	ASTM A276
A-34	Drain Valve Facing	Plastic	
A-35	Drain Valve Screw	Stainless Steel	ASTM A276
A-36	Upper Valve Plate (includes A-34 and A-35)	Bronze	ASTM B584
A-37	Shoe bolt and nut	Steel	ASTM A307 Plated
A-38	Drain Ring Housing O-ring	Rubber	ASTM D2000 BUNA N
A-39	Seat Ring Top O-ring	Rubber	ASTM D2000 BUNA N
A-40	Drain Ring Housing	Cast Iron	ASTM A126 CL.B
A-41	Drain Ring Housing Bolt and Nut	Steel	ASTM A307 Plated
A-42	Drain Ring	Bronze	ASTM B584
A-43	Seat Ring	Bronze	ASTM B584
A-44	Seat Ring Bottom O-ring	Rubber	ASTM D2000 BUNA N
A-45	Reversible Main Valve	Rubber	ASTM 2000
A-46	Lower Valve Plate	Cast Iron	ASTM A126 CL.B
A-47	Cap Nut Seal	Rubber	ASTM D2000
A-48	Lock Washer	Stainless Steel	ASTM A276
A-49	Lower Valve Plate Nut	Cast Iron	ASTM A126 CL.B
A-50	Shoe	Ductile Iron	ASTM A536 Grade 65-45-12
A-84	Hold Down Nut	Bronze	ASTM B584
A-85	Weather Seal	Rubber	ASTM D2000
A-52	Double O-ring	Rubber	ASTM D2000
A-53	Gripper Ring	Ductile Iron	ASTM A536 Grade 65-45-12
A-54	Breakaway nut w/ washer	Steel	
A-55	T-head bolt	Steel	
A-56	Intermediate Ring	Ductile Iron	ASTM A536 Grade 65-45-12
A-57	End-Ring	Ductile Iron	ASTM A536 Grade 65-45-12

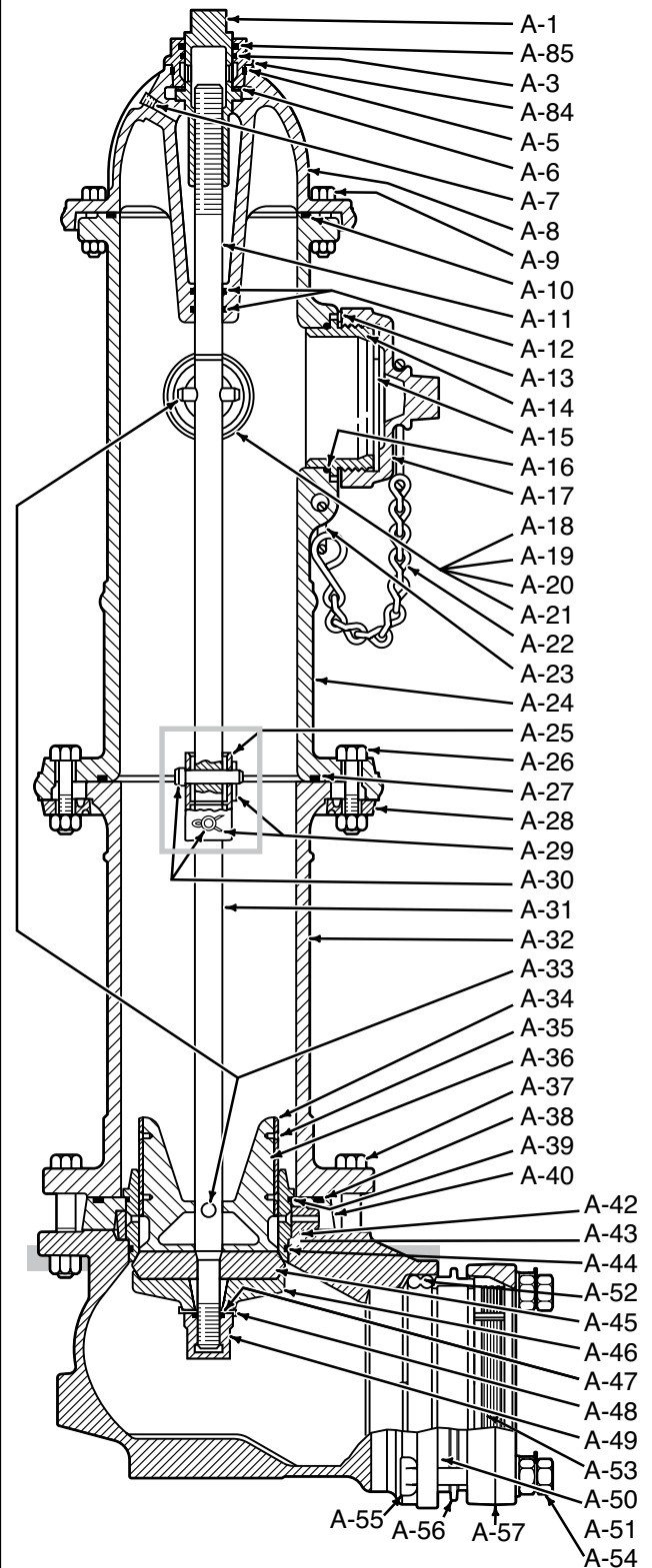

Rev. 8-04 Shaded area indicates changes

- ❑ **Super Centurion 250™ 3-way catalog numbers (approved to UL 246, FM 1510, ANSI/AWWA C502 Standards) -**
 - A-421 4-1/2" main valve opening three way (two hose nozzles and one pumper nozzle)
 - A-423 5-1/4" main valve opening three way (two hose nozzles and one pumper nozzle)
 - Super Centurion 200™ 2-way catalog numbers (approved to ANSI/AWWA C502 Standards) -**
 - A-420 4-1/2" main valve opening two way (two hose nozzles)
 - A-422 5-1/4" main valve opening two way (two hose nozzles)
 - A-425 5-1/4" main valve opening two way (two pumper nozzles)
 - Super Centurion 200™ 1-way catalog number (approved to ANSI/AWWA C502 Standards)-**
 - A-424 4-1/2" main valve opening one way (one pumper nozzle)
- ❑ 10 year limited warranty on material and workmanship
 - ❑ Meets all applicable parts of ANSI/AWWA C502 Standard
 - ❑ Post type dry barrel design
 - ❑ Dry top design with O-ring sealed oil reservoir
 - ❑ Traffic feature with stainless steel safety stem coupling
 - ❑ Compression-type main valve closes with pressure for positive seal; it is made of rubber and is conveniently reversible providing a spare for long service life
 - ❑ Operating nut available in wide variety of shapes and sizes-open left or right
 - ❑ Field replaceable hose and pumper nozzles
 - ❑ Hose and pumper nozzles have large radius, full flow openings for low friction loss
 - ❑ Contoured shoe is designed for full flow
 - ❑ Dual bronze drain valves provide effective barrel drainage
 - ❑ 250 psig (1723 kPa) maximum working pressure, 500 psig (3447 kPa) static test pressure for 3-way hydrants; 200 psig (1379 kPa) maximum working pressure, 400 psig (2758 kPa) static test pressure for 2-way and 1-way hydrants



Dimensions

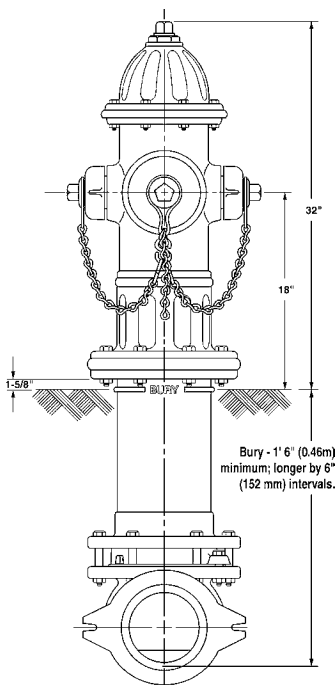

Mechanical joint standard and D-150

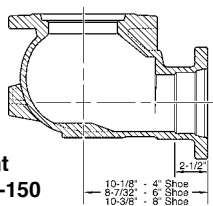

Flange ANSI 125/150 or PN 10/16 Drilling

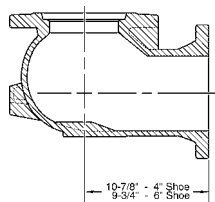

Slip-on

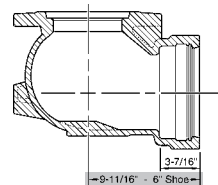

Non-rotating bolt design: cast-in pads eliminate need for anti-rotation bolts.

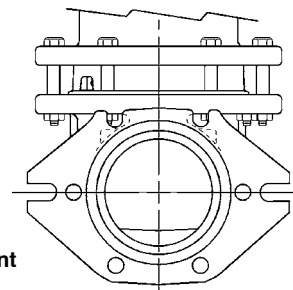

Front view detail of Mechanical joint (Standard only)

Vertical Flange*

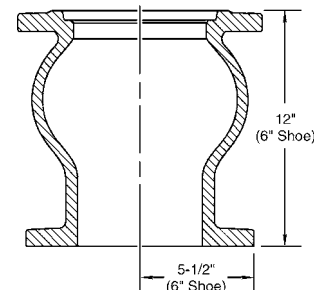

* 4" Vertical shoe available for A-420 and A-421 hydrants.

MUELLER® SUPER CENTURION® FIRE HYDRANT PARTS

Mueller Co.

9.9

Shaded area indicates changes Rev. 9-09

MUELLER Super Centurion Fire Hydrant Parts

Cat. part #	Description	Material	Material standard
A-1	Operating nut	Bronze	ASTM B584
A-2	Weather cap (not shown; used only on pre-1988 models)	Cast iron	ASTM A126 CL.B
A-3	Hold down nut O-ring	Rubber	ASTM D2000 BUNA N
A-4	Hold down nut (not shown; used only on pre-1988 models)	Bronze	ASTM B584
A-5	Bonnet O-ring	Rubber	ASTM D2000 BUNA N
A-6	Anti-friction washer	Celcon	
A-7	Oil plug	Brass	ASTM B16
A-8	Bonnet	Cast iron	ASTM A126 CL.B
A-9	Bonnet bolt and nut	Steel	ASTM A307 Plated
A-10	Bonnet O-ring (1997 and newer 3-way models; all pre-1997 models and 1-way and 2-way models have flat gasket)	Rubber	ASTM D2000 BUNA N
A-11	Upper stem	Steel	ASTM A576 GR.B
A-12	Stem O-ring	Rubber	ASTM D2000 BUNA N
A-13	Nozzle lock	Stainless steel	ASTM A276
A-14	Pumper nozzle	Bronze	ASTM B584
A-15	Pumper nozzle gasket	Rubber	ASTM D2000 Neoprene
A-16	Pumper nozzle O-ring	Rubber	ASTM D2000 BUNA N
A-17	Pumper nozzle cap	Cast iron	ASTM A126 CL.B
A-18	Hose nozzle	Bronze	ASTM B584
A-19	Hose nozzle gasket	Rubber	ASTM D2000 Neoprene
A-20	Hose nozzle O-ring	Rubber	ASTM D2000 BUNA N
A-21	Hose nozzle cap	Cast iron	ASTM A126 CL.B
A-22	Cap chain	Steel	Plated
A-23	Chain ring	Steel	Plated
A-24	Upper barrel less nozzles	Cast iron	ASTM A126 CL.B
A-25	Safety coupling	Stainless steel	ASTM A890
A-26	Safety flange bolt and nut	Steel	ASTM A307 Plated
A-27	Safety flange O-ring (1997 and newer models; pre-1997 models have flat gasket)	Rubber	ASTM D2000 BUNA N
A-28	Safety flange	Cast iron	ASTM A126 CL.B
A-29	Cotter pin	Stainless steel	ASTM A276
A-30	Clevis pin	Stainless steel	ASTM A276
A-31	Lower stem	Steel	ASTM A576 GR.B
A-32	Lower barrel	Cast iron	ASTM A126 CL.B
A-33	Stem pin	Stainless steel	ASTM A276
A-34	Drain valve facing	Plastic	
A-35	Drain valve screw	Stainless steel	ASTM A276
A-36	Upper valve plate (includes A-34 and A-35)	Bronze	ASTM B584
A-37	Shoe bolt and nut	Steel	ASTM A307 Plated
A-38	Drain ring housing O-ring (1997 and newer models; pre-1997 models have square gasket)	Rubber	ASTM D2000 BUNA N
A-39	Seat ring top O-ring	Rubber	ASTM D2000 BUNA N
A-40	Drain ring housing	Cast iron	ASTM A126 CL.B
A-41	Drain ring housing bolt and nut (not shown; used only on pre-1997 model hydrants)	Steel	ASTM A307 Plated
A-42	Drain ring	Bronze	ASTM B584
A-43	Seat ring	Bronze	ASTM B584
A-44	Seat ring bottom O-ring	Rubber	ASTM D2000 BUNA N
A-45*	Reversible main valve (1997 and newer models only; pre-1997 models use non-reversible main valve and lower valve plate - not shown)	Rubber	ASTM D2000
A-46	Lower valve plate (1997 and newer models for reversible main valve; pre-1997 models have non-reversible main valve - not shown)	Cast iron	ASTM A126 CL.B
A-47	Cap nut seal	Rubber	ASTM D2000
A-48	Lock washer	Stainless steel	ASTM A276
A-49	Lower valve plate nut	Cast iron	ASTM A126 CL.B
A-50	Shoe**	Cast iron	ASTM A126 CL. B
A-84	Hold down nut	Bronze	ASTM B584
A-85	Weather seal	Rubber	ASTM D2000
A-51	10.5 oz. hydrant lubricating oil (not shown)		

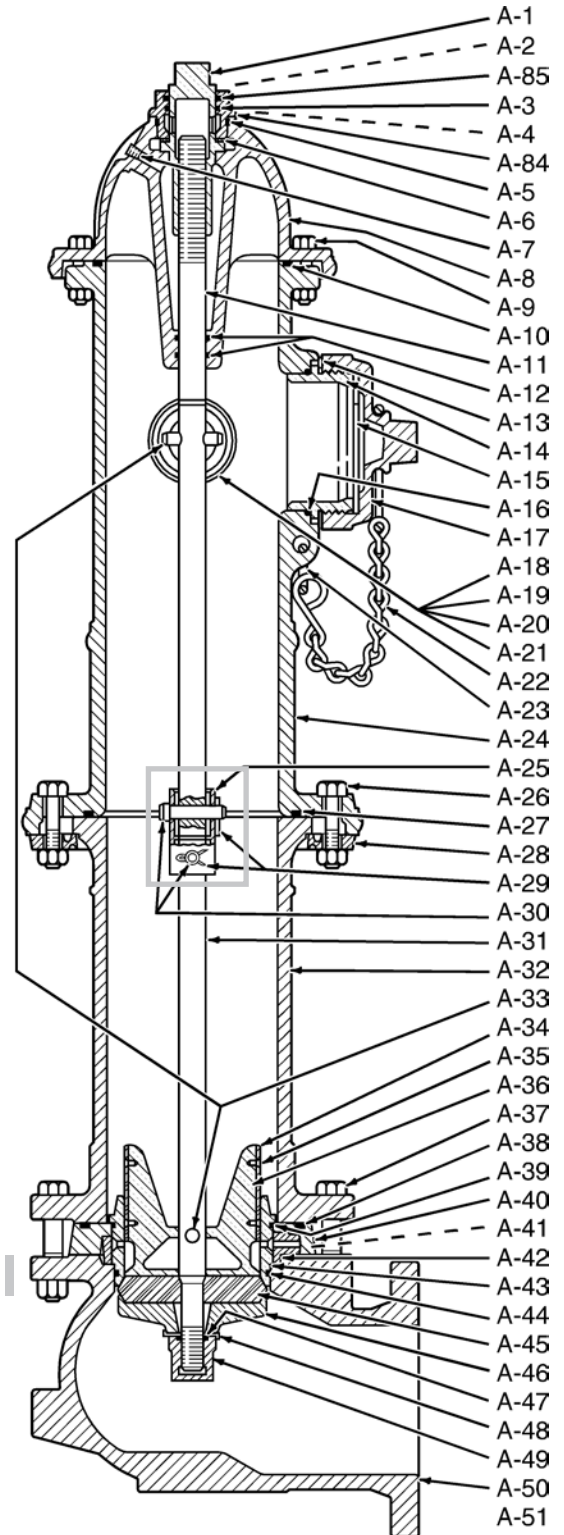

* Pre-1997 models may be upgraded to use the reversible main valve by also replacing the lower valve plate with the 1997 model.

** 6" MJ shoe is Ductile Iron, ASTM A536 Grade 65-45-12.



A-311

A-311 Operating wrench --- operates nozzle caps, pin and lug type hose couplings, hydrant operating nut, and hold down nut.



A-367

A-367 Brass sleeve --- protects O-rings from damage when removing the bonnet from upper stem.



A-316

A-316 Nozzle wrench--- Used to remove and install threaded in hose and pumper nozzles.

Sizes: 2-1/2", 3", 3-1/2", 4", 4-1/2", and 5"



240885

Heavy Duty Centurion Hold Down Nut Wrench



A-359

A-359 Seat wrench --- universal fit, used to remove main valve and seat ring from bonnet level or ground line. Wrench self-centers on barrel flange. Used on all Centurion, Modern and 107® Hydrants.



A-359-00

A-359-00 Seat wrench --- universal fit, used to remove main valve and seat ring from bonnet level or ground line. Wrench self-centers on barrel flange. Used on all Super Centurion models and Super 200 and 250.



A-51

A-51 Hydrant lubricating oil --- 10.5 ounce container of all-weather oil.



A-317

A-317 Nozzle lock installation tool --- used to install nozzle locking device.

Integral Storz Wrench

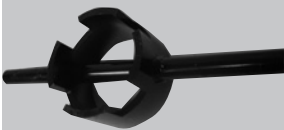

--- used to remove the integral Storz Pumper Connection.

Sizes - 4" - 287402
5" - 287403

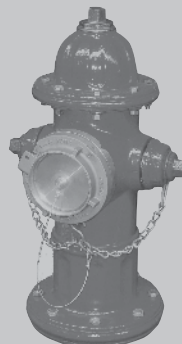

Integral Storz Pumper Connection

--- used to quickly connect to hydrants. Available on Centurion 200™, 250™ or Modern hydrant.

MUELLER® SUPER CENTURION® FIRE HYDRANT REPAIR KITS

Mueller Co.

9.11

Shaded area indicates changes Rev. 5-11

Bonnet Repair Kit



Bonnet Repair Kit consists of ---

- (1) Weather seal
- (2) Hold down nut O-rings
- (2) Bonnet O-rings
- (1) Bonnet/Upper barrel O-ring
- (1) Anti-friction washer
- (1) Bonnet flange gasket
- (3) Stem O-rings
- (1) 10.5 oz. Hydrant lubricating oil
- (1) Instruction sheet

Kit catalog number

4-1/2" M.V.O.	5-1/4" M.V.O.
280355	280355

Main Valve Repair Kit



Main Valve Repair Kit consists of ---

- (1) Top seat O-rings
- (1) Bottom seat O-rings
- (1) Main valve (reversible)
- (1) Lower valve plate (reversible)
- (1) Cap nut seals
- (1) Bronze seat ring
- (1) Instruction sheet

Kit catalog number

4-1/2" M.V.O.	5-1/4" M.V.O.
280358	280359

Extension Kit

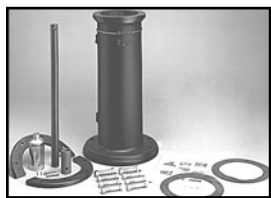

Extension Kit consists of ---

- (1) Stem
- (1) Barrel
- (1) Stainless steel extension stem coupling
- (1) Extension flange
- (1) Bonnet/Upper barrel O-ring
- (3) Gaskets
- (1) Bonnet/Upper barrel O-ring
- (8) Bolts and nuts
- (2) Clevis pins
- (3) Cotter pins
- (1) Instruction sheet
- (1) 10.5 oz. hydrant lubricating oil
- Extension lengths: 0'-6", 1'-0", 1'-6", 2'-0", 2'-6", 3'-0", 3'-6", 4'-0"

Kit catalog number

4-1/2" M.V.O.	5-1/4" M.V.O.
A-319	A-320

Safety Flange Repair Kit



Safety Flange Repair Kit consists of ---

- (1) Safety flange
- (2) Gaskets
- (8) Safety flange bolts and nuts
- (1) Safety flange O-ring
- (1) Bonnet/Upper barrel O-ring
- (1) 10.5 oz. hydrant lubricating oil
- (1) Stainless steel safety stem coupling
- (2) Clevis pins
- (3) Cotter pin
- (1) Instruction sheet

Kit catalog number

4-1/2" M.V.O.	5-1/4" M.V.O.
A-300	A-301

Shoe Repair Kit



Shoe Repair Kit consists ---

- (2) Drain valve facings
- (6) Drain valve facing screws
- (1) Drain ring housing gasket
- (1) Top seat O-ring
- (1) Bottom seat O-ring
- (1) Gasket
- (1) Main valve (reversible)
- (1) Lower valve plate (reversible)
- (1) Cap nut seal
- (1) Lock washer
- (6) Shoe bolts and nuts
- (2) Drain ring bolts and nuts
- (1) 10.5 oz. hydrant lubricating oil
- (1) Instruction sheet

Kit catalog number

4-1/2" M.V.O.	5-1/4" M.V.O.
280356	280357

A-417 107® Conversion Kit

Replaces 107 hydrant bonnet with Centurian stop-in-bonnet style. Open left, 1-1/2" pentagon operating nut.

Bonnet Replacement Kit consists of ---

- (1) Bonnet
- (1) Bonnet gasket
- (8) Bonnet bolts/nuts
- (1) Operating nut
- (1) Hold down nut
- (1) Stop nut
- (1) Oil plug
- (1) Anti-friction washer
- (1) Weather seal
- (1) Hold down nut O-ring
- (2) Bonnet O-rings
- (3) Steam O-rings
- (1) Upper stem assembly
- (1) 10.5 oz. hydrant lubricating oil
- (1) Instruction sheet form 11089

Rev. 8-04

- ❑ Catalog numbers -
 - A-441 5-1/4" main valve opening two way (two hose nozzles)
 - A-442 5-1/4" main valve opening three way (two hose nozzles and one pumper nozzle)
- ❑ Modern, sleek exterior design
- ❑ Meets all applicable parts of ANSI/AWWA C502 Standard
- ❑ Post type dry barrel design
- ❑ Dry top design with O-ring sealed oil reservoir
- ❑ Traffic feature with stainless steel safety stem coupling
- ❑ Compression type main valve closes with pressure for positive seal; it is made of rubber and is conveniently reversible providing a spare for long service life
- ❑ Operating nut available in wide variety of shapes and sizes
- ❑ Field replaceable hose and pumper nozzles
- ❑ Hose and pumper nozzles have large radius, full flow openings for low friction loss
- ❑ Contoured shoe is designed for full flow
- ❑ Dual bronze drain valves provide effective barrel drainage
- ❑ 200 psig (1379 kPa) maximum working pressure, 400 psig (2758 kPa) test pressure



Dimensions

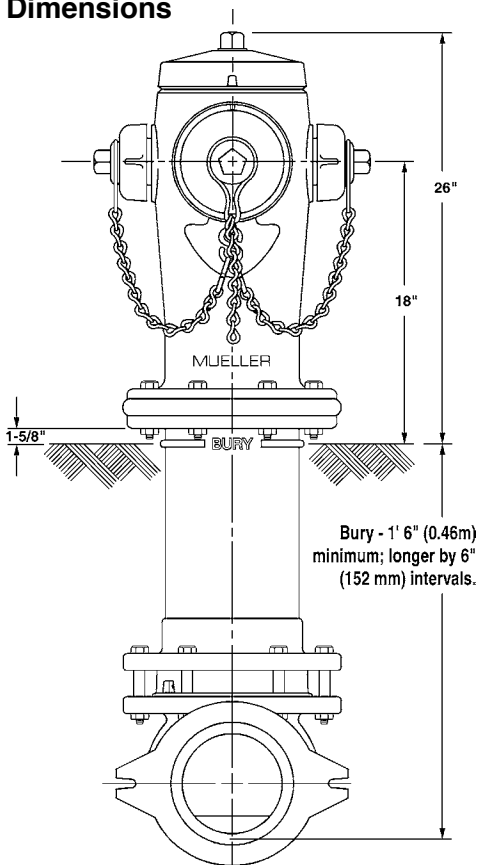

Mechanical joint
standard and D-150

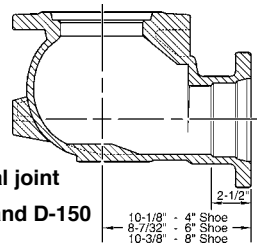

Non-rotating bolt design: cast-in pads eliminate need for anti-rotation bolts.

Front view detail of Mechanical joint (Standard only)

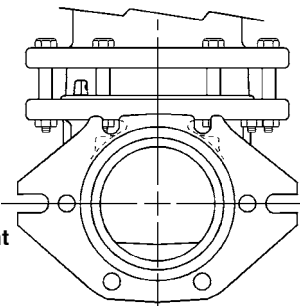

Flange
ANSI 125/150 or
PN 10/16 Drilling

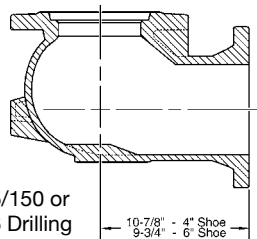

Vertical Flange

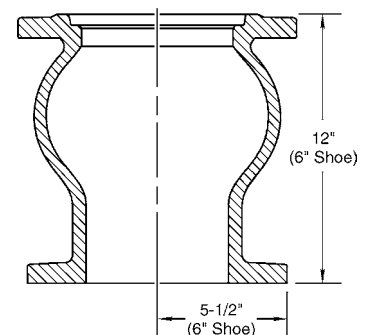

Slip-on

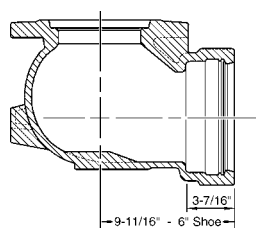

MUELLER® MODERN CENTURION® FIRE HYDRANT PARTS

Mueller Co.

9.13

Shaded area indicates changes Rev. 9-09

MUELLER Modern Centurion Fire Hydrant Parts

Cat. part no.	Description	Material	Material standard
A-3	Hold down nut O-ring	Rubber	ASTM D2000 BUNA N
A-5	Bonnet O-ring	Rubber	ASTM D2000 BUNA N
A-6	Anti-friction washer	Celcon	
A-7	Oil plug	Brass	ASTM B16
A-12	Stem O-ring	Rubber	ASTM D2000 BUNA N
A-13	Nozzle lock	Stainless steel	ASTM A276
A-14	Pumper nozzle	Bronze	ASTM B584
A-15	Pumper nozzle gasket	Rubber	ASTM D2000 Neoprene
A-16	Pumper nozzle O-ring	Rubber	ASTM D2000 BUNA N
A-17	Pumper nozzle cap	Cast iron	ASTM A126 CL.B
A-18	Hose nozzle	Bronze	ASTM B584
A-19	Hose nozzle gasket	Rubber	ASTM D2000 Neoprene
A-20	Hose nozzle O-ring	Rubber	ASTM D2000 BUNA N
A-21	Hose nozzle cap	Cast iron	ASTM A126 CL.B
A-22	Cap chain	Steel	Plated
A-23	Chain ring	Steel	Plated
A-25	Safety coupling	Stainless steel	ASTM 890
A-26	Safety flange bolt and nut	Steel	ASTM A307 Plated
A-27	Safety flange gasket	Rubber	ASTM D2000 BUNA N
A-28	Safety flange	Cast iron	ASTM A126 CL.B
A-29	Cotter pin	Stainless steel	ASTM A276
A-30	Clevis pin	Stainless steel	ASTM A276
A-31	Lower stem	Steel	ASTM A576 GR.1117
A-32	Lower barrel	Cast iron	ASTM A126 CL.B
A-33	Stem pin	Stainless steel	ASTM A276
A-34	Drain valve facing	Plastic	
A-35	Drain valve screw	Stainless steel	ASTM A276
A-36	Upper valve plate (includes A-34 and A-35)	Bronze	ASTM B584
A-37	Shoe bolt and nut	Steel	ASTM A307 Plated
A-38	Drain ring housing O-ring (1997 and newer models; pre-1997 models have flat gasket)	Rubber	ASTM D2000 BUNA N
A-39	Seat ring top O-ring	Rubber	ASTM D2000 BUNA N
A-40	Drain ring housing	Cast iron	ASTM A126 CL.B
A-41	Drain ring housing bolt and nut (not shown; used only on pre-1997 model hydrants)	Steel	ASTM A307 Plated
A-42	Drain ring	Bronze	ASTM B584
A-43	Seat ring	Bronze	ASTM B584
A-44	Seat ring bottom O-ring	Rubber	ASTM D2000 BUNA N
A-45*	Reversible main valve (1997 and newer models only; pre-1997 models use non-reversible main valve and lower valve plate - not shown)	Rubber	ASTM D2000
A-46	Lower valve plate (1997 and newer models for reversible main valve; pre-1997 models have non-reversible main valve - not shown)	Cast iron	ASTM A126 CL.B
A-47	Cap nut seal	Rubber	ASTM D2000
A-48	Lock washer	Stainless steel	ASTM A276
A-49	Lower valve plate nut	Cast iron	ASTM A126 CL.B
A-50	Shoe**	Cast iron	ASTM A126 CL.B
A-51	10.5 oz. hydrant lubricating oil (not shown)		
A-52	Operating nut	Bronze	ASTM B584
A-53	Weather cap	Cast iron	ASTM A126 CL. B
A-54	Hold down nut	Bronze	ASTM B584
A-55	Housing	Cast iron	ASTM A126 CL.B
A-56	Housing bolt	Steel	ASTM A307 Plated
A-57	Top housing O-ring	Rubber	ASTM D2000
A-58	Upper stem	Steel	ASTM A576 GR.1117
A-59	Upper barrel less nozzles	Cast iron	ASTM A126 CL.B

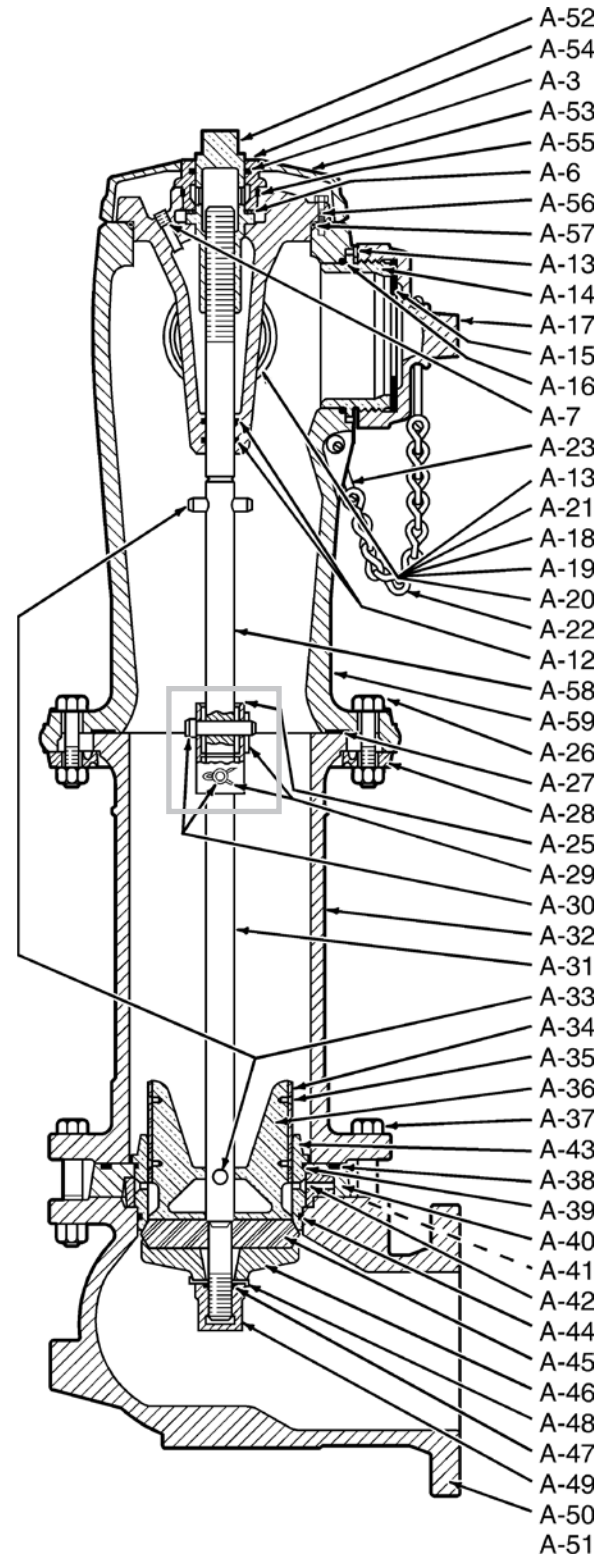

* Pre-1997 models may be upgraded to use the reversible main valve by also replacing the lower valve plate with the 1997 model.

** 6" MJ shoe material is Ductile Iron, ASTM A536 Grade 65-45-12.



A-311

A-311 Operating wrench --- operates nozzle caps, pin and lug type hose couplings, hydrant operating nut, and hold down nut.



A-368

A-368 Brass sleeve --- protects O-rings from damage when removing the bonnet from upper stem.



A-359

A-359 Seat wrench --- universal fit, used to remove main valve and seat ring from bonnet level or ground line. Wrench self-centers on barrel flange. Used on all Centurion, Modern and 107® Hydrants.



A-359-00

--- universal fit, used to remove main valve and seat ring from bonnet level or ground line. Wrench self-centers on barrel flange. Used on all Super Centurion models and Super 200 and 250.



A-316

A-316 Nozzle wrench--- Used to remove and install threaded in hose and pumper nozzles.

Sizes: 2-1/2", 3", 3-1/2", 4", 4-1/2", and 5"



A-317

A-317 Nozzle lock installation tool --- used to install nozzle locking device.



A-51

A-51 Hydrant lubricating oil --- 10.5 ounce container of all-weather oil.

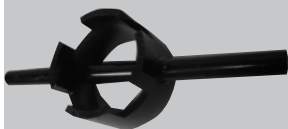

Integral Storz Wrench

--- used to remove the integral Storz Pumper Connection.

Sizes - 4" - 287402
5" - 287403

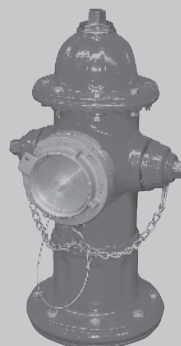

Integral Storz Pumper Connection

--- used to quickly connect to hydrants. Available on Centurion 200™, 250™ or Modern hydrant.

Shoe Repair Kit



Shoe Repair Kit consists of---

- (2) Drain valve facings
- (6) Drain valve facing screws
- (1) Drain ring housing gasket
- (1) Drain ring housing O-ring
- (1) Top seat O-ring
- (1) Bottom seat O-ring
- (1) Main valve (reversible)
- (1) Lower valve plate (reversible)
- (1) Cap nut seal
- (1) Lock washer
- (6) Shoe bolts and nuts
- (2) Drain ring bolts and nuts
- (1) 10.5 oz. hydrant lubricating oil
- (1) Instruction sheet

Kit catalog number
5-1/4" M.V.O.
280357

Main Valve Repair Kit



Main Valve Repair Kit consists of---

- (2) Top seat O-rings
- (2) Bottom seat O-rings
- (1) Main valve (reversible)
- (1) Lower valve plate (reversible)
- (2) Cap nut seals
- (1) Bronze seat ring
- (1) Instruction sheet

Kit catalog number
5-1/4" M.V.O.
280359

Extension Kit

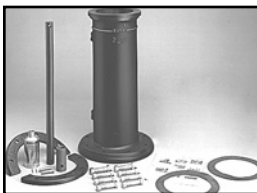

Extension Kit consists of ---

- (1) Stern
- (1) Barrel
- (1) Stainless steel extension stem coupling
- (1) Extension flange
- (2) Gaskets
- (8) Bolts and nuts
- (2) Clevis pins
- (3) Cotter pins
- (1) 10.5 oz. hydrant lubricating oil
- (1) Instruction sheet
- Extension lengths: 0'-6", 1'-0", 1'-6", 2'-0", 2'-6", 3'-0", 3'-6", 4'-0", 4'-6" and 5'-0"

Kit catalog number
5-1/4" M.V.O.
A-320

Safety Flange Repair Kit consists of---



- (1) Safety flange
- (2) Gaskets
- (8) Safety flange bolts and nuts
- (1) Safety flange O-ring
- (1) Bonnet/Upper barrel O-ring
- (1) 10.5 oz. hydrant lubricating oil
- (1) Stainless steel safety stem coupling
- (2) Clevis pins
- (3) Cotter pins
- (1) Instruction sheet

Kit catalog number
5-1/4" M.V.O.
A-301

Rev. 8-04

- ❑ Catalog numbers--
 - A-465 4-1/2"* main valve opening three way (two hose nozzles and one pumper nozzle) fits 4-1/2" bronze lined R.D.Wood shoe
 - A-466 4-1/2"* main valve opening three way (two hose nozzles and one pumper nozzle) fits 4" regular R.D.Wood shoe
 - A-467 5-1/4" main valve opening three way (two hose nozzles and one pumper nozzle) fits 6" regular R.D.Wood shoe
 - A-468 5-1/4" main valve opening three way (two hose nozzles and one pumper nozzle) fits 5" bronze lined R.D.Wood shoe
- ❑ Meets all applicable parts of ANSI/AWWA C502 Standard
- ❑ Post type dry barrel design
- ❑ Dry top design with O-ring sealed oil reservoir
- ❑ Traffic feature with stainless steel safety stem coupling
- ❑ Compression type patented main valve closes with pressure for positive seal; it is made of rubber and is conveniently reversible providing a spare for long service life
- ❑ Operating nut available in wide variety of shapes and sizes
- ❑ Field replaceable hose and pumper nozzles
- ❑ Hose and pumper nozzles have large radius, full flow openings for low friction loss
- ❑ Dual bronze drain valves provide effective barrel drainage
- ❑ 200 psig (1379 kPa) maximum working pressure, 400 psig (2758 kPa) test pressure

*4-1/2" M.V.O. hydrants have 5-1/4" bonnets, upper barrels, safety flanges and lower barrels and are marked 5-1/4" even though the main valve opening is 4-1/2".

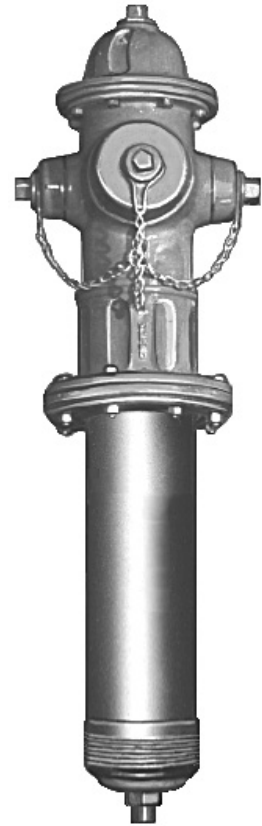

Dimensions

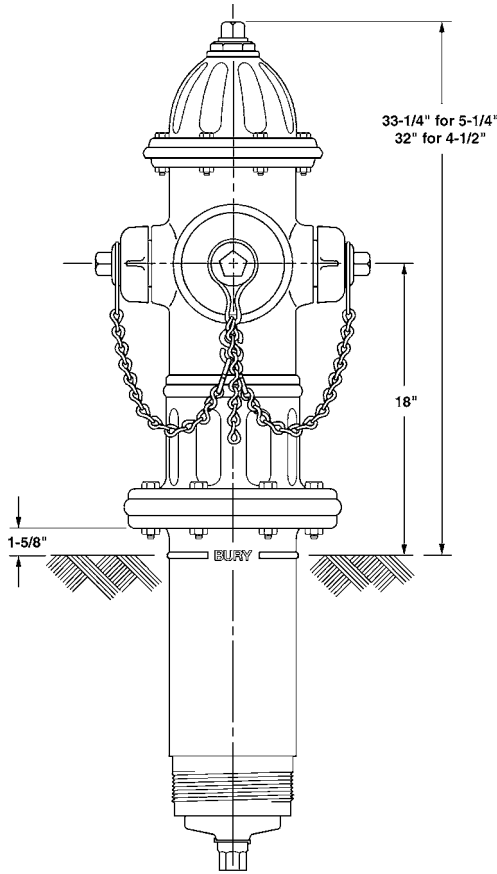

MUELLER® CENTURION® SPIN-IN FIRE HYDRANT PARTS



9.17

Shaded area indicates changes Rev. 9-09

MUELLER Centurion Spin-in Fire Hydrant

Cat. part no.	Description	Material	Material standard
A-1	Operating nut	Bronze	ASTM B584
A-2	Weather cap (not shown; used only on pre-1988 models)	Cast iron	ASTM A126 CL.B
A-3	Hold down nut O-ring	Rubber	ASTM D2000 BUNA N
A-4	Hold down nut (not shown; used only on pre-1988 models)	Bronze	ASTM B584
A-5	Bonnet O-ring	Rubber	ASTM D2000 BUNA N
A-6	Anti-friction washer	Celcon	
A-7	Oil plug	Brass	ASTM B16
A-8	Bonnet	Cast iron	ASTM A126 CL.B
A-9	Bonnet bolt and nut	Steel	ASTM A307 Plated
A-10	Bonnet O-ring (1997 and newer models; pre-1997 models have flat gasket)	Rubber	ASTM D2000 BUNA N
A-11	Upper stem	Steel	ASTM A576 GR.B
A-12	Stem O-ring	Rubber	ASTM D2000 BUNA N
A-13	Nozzle lock	Stainless steel	ASTM A276
A-14	Pumper nozzle	Bronze	ASTM B584
A-15	Pumper nozzle gasket	Rubber	ASTM D2000 Neoprene
A-16	Pumper nozzle O-ring	Rubber	ASTM D2000 BUNA N
A-17	Pumper nozzle cap	Cast iron	ASTM A126 CL.B
A-18	Hose nozzle	Bronze	ASTM B584
A-19	Hose nozzle gasket	Rubber	ASTM D2000 Neoprene
A-20	Hose nozzle O-ring	Rubber	ASTM D2000 BUNA N
A-21	Hose nozzle cap	Cast iron	ASTM A126 CL.B
A-22	Cap chain	Steel	Electrogalvanized
A-23	Chain ring	Steel	Electrogalvanized
A-24	Upper barrel less nozzles	Cast iron	ASTM A126 CL.B
A-25	Safety coupling	Steel	ANSI C1018 Plated
A-26	Safety flange bolt and nut	Steel	ASTM A307 Plated
A-27	Safety flange O-ring (1997 and newer models; pre-1997 models have flat gasket)	Rubber	ASTM D2000 BUNA N
A-28	Safety flange	Cast iron	ASTM A126 CL.B
A-29	Cotter pin	Stainless steel	ASTM A276
A-30	Clevis pin	Stainless steel	ASTM A276
A-31	Lower stem	Steel	ASTM A576 GR.B
A-32	Lower barrel	Cast iron	ASTM A126 CL.B
A-33	Stem pin	Stainless steel	ASTM A276
A-34	Drain valve facing	Plastic	
A-35	Drain valve screw	Stainless steel	ASTM A276
A-36	Upper valve plate (includes A-34 and A-35)	Bronze	ASTM B584
A-45*	Reversible main valve (1997 and newer models only; pre-1997 models use non-reversible main valve and lower valve plate - not shown)	Rubber	ASTM D2000
A-46	Lower valve plate (1997 and newer models for reversible main valve; pre-1997 models have non-reversible main valve - not shown)	Cast iron	ASTM A126 CL.B
A-47	Cap nut seal	Rubber	ASTM D2000
A-48	Lock washer	Stainless steel	ASTM A276
A-49	Lower valve plate nut	Cast iron	ASTM A126 CL.B
A-51	10.5 oz. hydrant lubricating oil (not shown)		
A-84	Hold down nut	Bronze	ASTM B584
A-85	Weather seal	Rubber	ASTM D2000
A-200	Sleeve O-ring	Rubber	ASTM D2000 Nitrile
A-201	Sleeve	Copper	ASTM B75
A-202	Stop nut	Ductile iron	ASTM A395
A-250	Seat ring	Bronze	ASTM B584
A-251	Top seat ring gasket	Rubber	ASTM D2000 Nitrile
A-252	Bottom seat ring gasket	Rubber	ASTM D2000 Nitrile

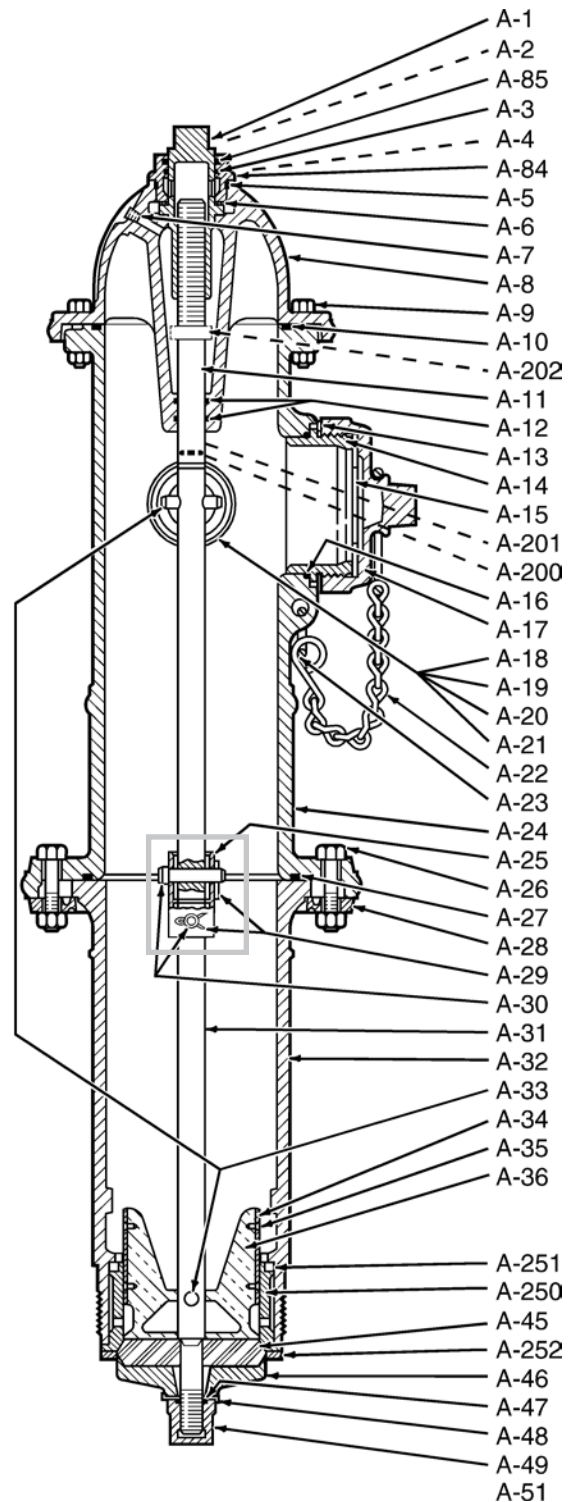

* Pre-1997 models may be upgraded to use the reversible main valve by also replacing the lower valve plate with the 1997 model.

Rev. 8-04 Shaded area indicates changes



A-311

A-311 Operating wrench --- operates nozzle caps, pin and lug type hose couplings, hydrant operating nut, and hold down nut.



A-367

A-367 Brass sleeve --- protects O-rings from damage when removing the bonnet from upper stem.



A-316

A-316 Nozzle wrench --- Used to remove and install threaded in hose and pumper nozzles. **Sizes:** 2-1/2", 3", 3-1/2", 4", 4-1/2", and 5"



A-359

A-359 Seat wrench --- universal fit, used to remove main valve and seat ring from bonnet level or ground line. Wrench self-centers on barrel flange. Used on all Centurion Modern and 107® Hydrants.



A-317

A-317 Nozzle lock installation tool --- used to install nozzle locking device.



A-51

A-51 Hydrant lubricating oil --- 10.5 ounce container of all-weather oil.

Bonnet Repair Kit



Bonnet Repair Kit consists of---

- (1) Weather seal
- (1) Hold down nut O-ring
- (1) Bonnet O-ring
- (1) Bonnet/Upper barrel O-ring
- (1) Anti-friction washer
- (1) Bonnet gasket
- (2) Stem O-rings
- (1) 10.5 oz. Hydrant lubricating oil

Kit catalog number
5-1/4" M.V.O.
280355

Safety Flange Repair Kit



Safety Flange Repair Kit consists of---

- (1) Safety flange
- (2) Gaskets
- (8) Safety flange bolts and nuts
- (1) Safety flange O-ring
- (1) Bonnet/Upper barrel O-ring
- (1) 10.5 oz. hydrant lubricating oil
- (1) Stainless steel safety stem coupling
- (2) Clevis pins
- (3) Cotter pins
- (1) Instruction sheet

Kit catalog number
5-1/4" M.V.O.
A-301

Extension Kit

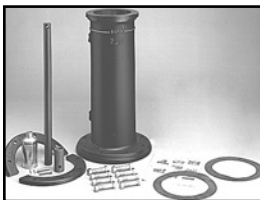

Extension Kit consists of ---

- (1) Stem
- (1) Barrel
- (1) Bonnet/Upper barrel O-ring
- (1) Stainless steel extension stem coupling
- (1) Extension flange
- (1) Safety flange O-ring
- (2) Gaskets
- (8) Bolts and nuts
- (2) Clevis pins
- (2) Cotter pins
- (1) 10.5 oz. hydrant lubricating oil
- (1) Instruction sheet

Kit catalog number
5-1/4" M.V.O.
A-320

Rev. 8-04

- ❑ Catalog Numbers ---
A-415 5-1/4" main valve opening three way (two hose nozzles and one pumper nozzle)
- ❑ Meets all applicable parts of ANSI/AWWA C502 Standard
- ❑ Flush type dry barrel design
- ❑ Dry top design with O-ring sealed oil reservoir
- ❑ Cast iron flush box with non-locking lid
- ❑ Compression type patented main valve closes with pressure for positive seal; it is made of rubber and is conveniently reversible providing a spare for long service life
- ❑ Operating nut available in wide variety of shapes and sizes
- ❑ Hose and pumper nozzles have large radius, full flow openings for low friction loss
- ❑ Contoured shoe is designed for full flow
- ❑ Dual bronze drain valves provide effective barrel drainage
- ❑ 150 psig (1034kPa) maximum working pressure, 300 psig (2068 kPa) test pressure

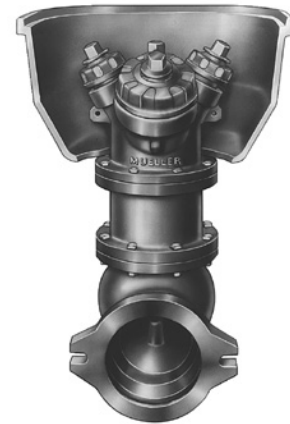

Dimensions

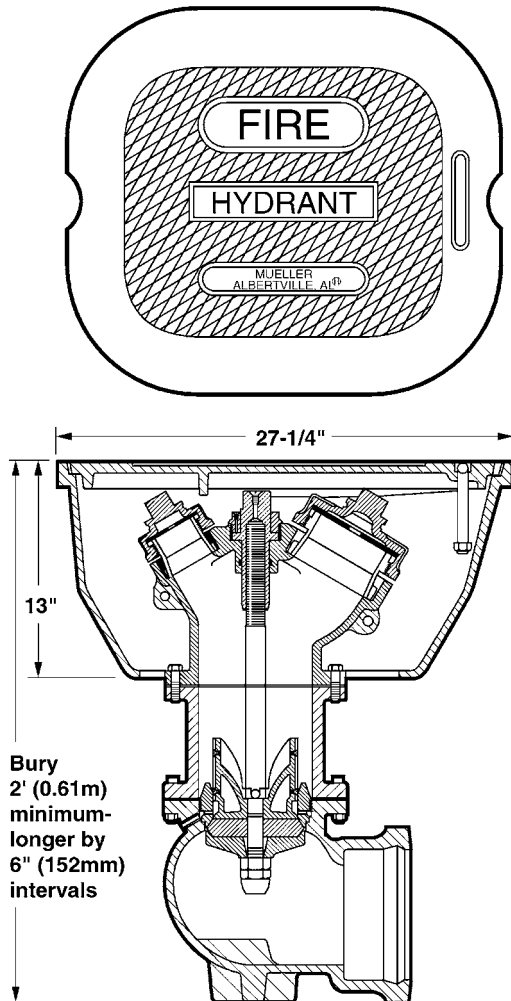

Mechanical joint - standard and D-150

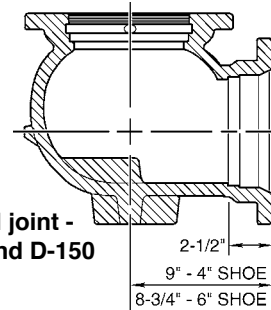

Flanged

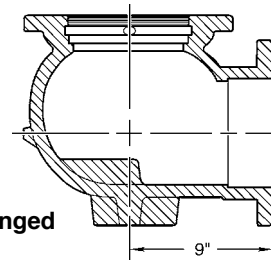

Slip-on

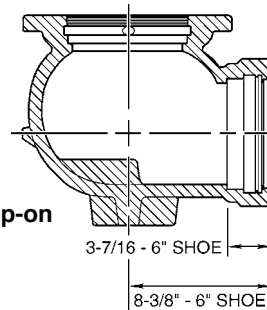

MUELLER® 5-1/4" FLUSH TYPE FIRE HYDRANT

MUELLER 5-1/4" Flush Type Fire Hydrant

Cat. part no.	Description	Material	Material standard
1	Flush Box Lid (non-locking)	Cast iron	ASTM A126 CL. B
2	Lift Handle		
3	Lift Handle Nut		
4	Flush Box	Cast iron	ASTM A126 CL. B
5	Pumper Nozzle Cap	Cast iron	ASTM A126 CL. B
6	Pumper Nozzle Gasket	Rubber	ASTM D2000 Neoprene
7	Pumper Nozzle	Bronze	ASTM B584
8	Hose Nozzle Cap	Cast iron	ASTM A126 CL. B
9	Hose Nozzle Gasket	Rubber	ASTM D2000 Neoprene
10	Hose Nozzle	Bronze	ASTM B584
11	Oil Screw for operating nut	Brass	ASTM B36
12	Operating Nut	Bronze	ASTM B584
13	Oil Screw in Hold Down Nut	Brass	ASTM B36
14	Hold Down Nut	Bronze	ASTM B584
15	Upper Barrel	Cast iron	ASTM A126 CL. B
16	Hold Down Nut O-ring	Rubber	ASTM D2000 Neoprene
17	O-ring Seal	Rubber	ASTM D2000 Neoprene
18	Cap Screw	Steel	
19	Barrel Flange Gasket	Rubber	ASTM D2000 Neoprene
20	Lower Barrel	Cast iron	ASTM A126 CL. B
21	Stem	Steel	ASTM A576 GR. B
22	Upper Valve Plate	Bronze	ASTM B584
23	Drain Valve Facing	Leather	
24	Drain Valve Facing Screw	Stainless Steel	ASTM A307
25	Seat Ring	Bronze	ASTM B584
26	Shoe Bolt & Nut	Steel	ASTM A307 Plated
28	Stem Pin	Stainless Steel	
29*	Main Valve <i>1997 and newer modles for reversible main valve; pre 1997 modlest have non-reversible main vlave and lower valve plate - not shown</i>		
30	Lower Valve Plate <i>1997 and newer modles for reversible main valve; pre 1997 modlest have non-reversible main vlave and lower valve plate - not shown</i>	Cast iron	ASTM A126 CL. B
31	Valve Plate Nut	Bronze	ASTM B584
32	Cap Nut Seal		
33	Lock Washer		
34	Drain Ring		
35	Drain Ring Houseing		
36	Shoe		
37	Pumper Nozzle O-ring		
38	Hose Nozzle O-ring		
39	Nozzle Lock		
40	Chain Hook		
41	Chain		
42	Top Seat O-ring		
43	Bottom Seat O-ring		
44	Drain Ring O-ring		

* Pre-1997 models may be upgraded to use the reversible main valve by also replacing the lower main valve plate with the 1997 model.

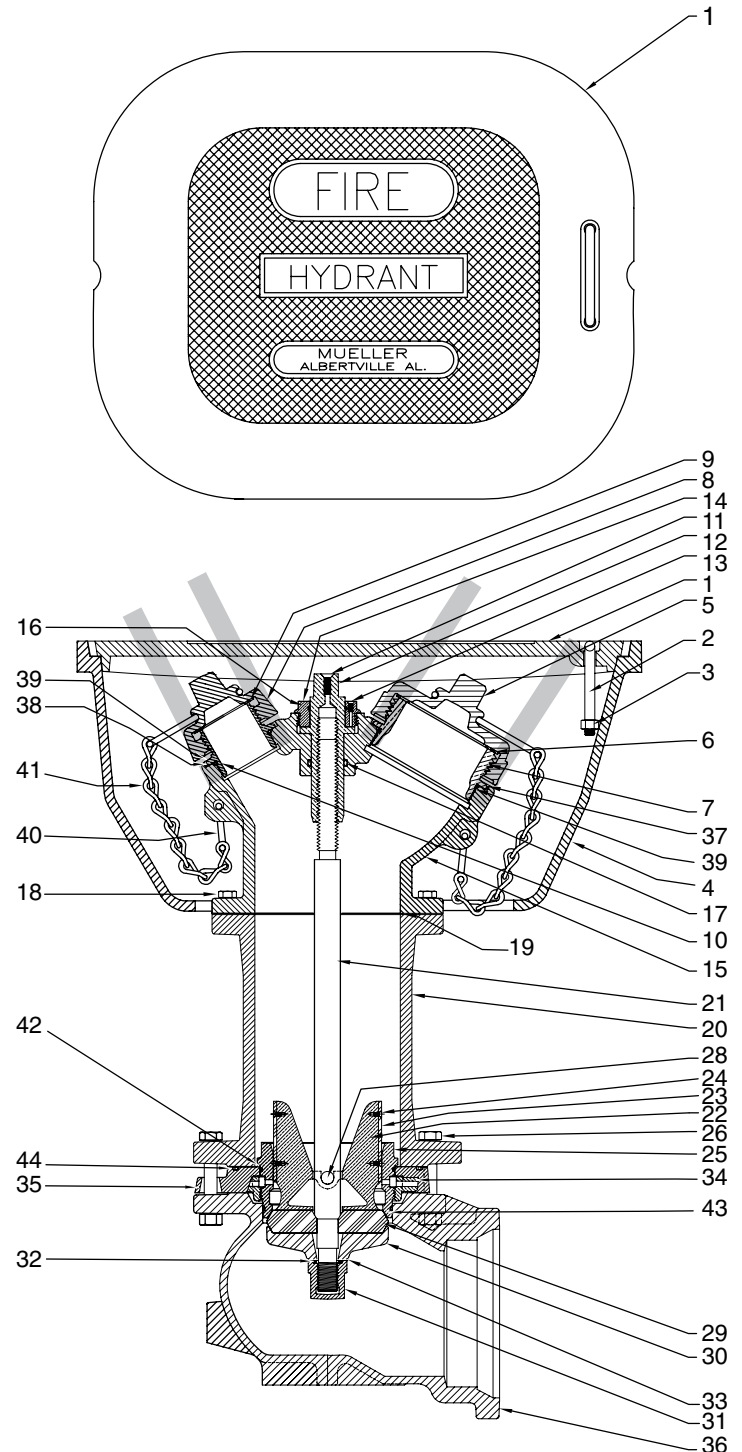

Rev. 8-04 Shaded area indicates changes



A-314

A-314 Operating wrench --- operates nozzle caps, pin and lug type hose couplings, hydrant operating nut, and hold down nut.

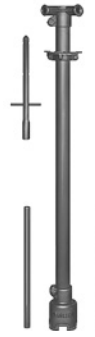

A-346

A-346 Seat wrench --- Adjustable, used to remove main valve and seat ring from ground line level. For use with A-415 hydrant.



A-316

A-316 Nozzle wrench --- Used to remove and install threaded in hose and pumper nozzles.

Sizes: 2-1/2", 3", 3-1/2", 4", 4-1/2", and 5"



A-317

A-317 Nozzle lock installation tool --- used to install nozzle locking device.



www.muellercompany.com
moreinfo@muellercompany.com

Rev. 9-09

- ❑ Catalog numbers --
 - A-411 2-1/8" main valve opening two way (two 2-1/2" hose nozzles)
 - A-411 2-1/8" main valve opening one way (one 2-1/2" hose nozzle)
- ❑ Meets all applicable parts of ANSI/AWWA C502 Standard
- ❑ Post type dry barrel design
- ❑ Compression type main valve closes with pressure
- ❑ Operating nut available in wide variety of shapes and sizes
- ❑ Field replaceable hose nozzles
- ❑ Hose nozzles have large radius, full flow openings for low friction loss
- ❑ Contoured shoe is designed for full flow
- ❑ Dual bronze drain valves provide effective barrel drainage
- ❑ 150 psig (1034 kPa) maximum working pressure, 300psig (2068 kPa) test pressure



Dimensions

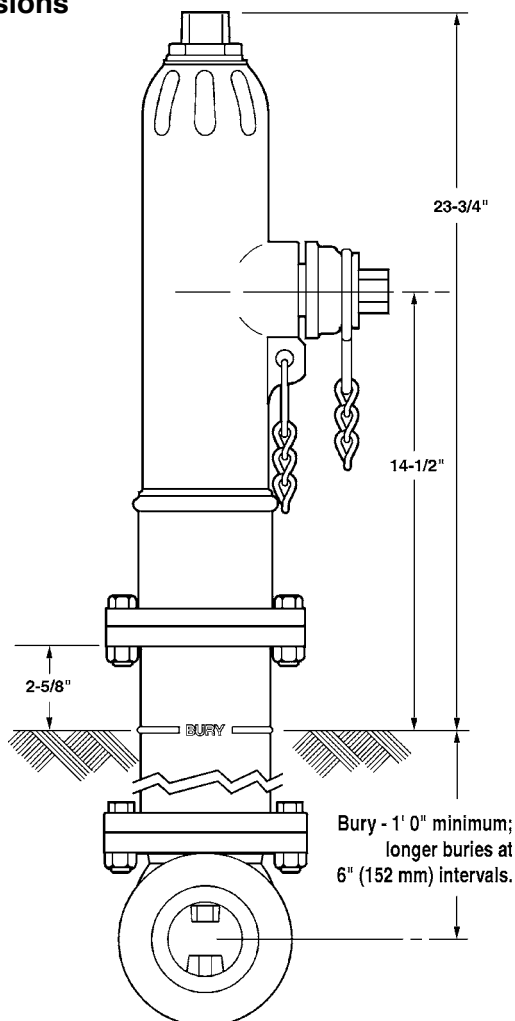

Mechanical joint

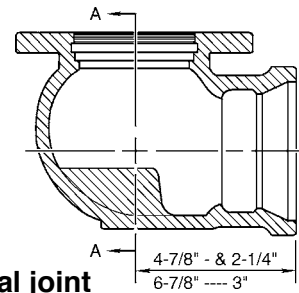

Flange

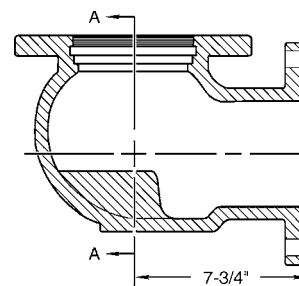

Threaded

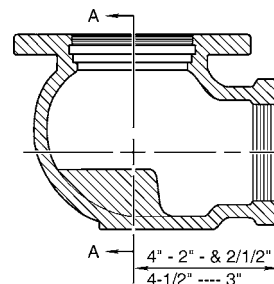

MUELLER® 2-1/8" POST TYPE FIRE HYDRANT

Mueller Co.

9.25

Rev. 8-04

MUELLER 2-1/8" Post Type Fire Hydrant

Cat. part no.	Description	Material	Material standard
1	Oil screw for operating nut	Brass	ASTM B36
2	Operating nut	Bronze	ASTM B584
3	Hold down nut	Bronze	ASTM B584
6	Operating nut O-ring	Rubber	ASTM D2000 BUNA-N
8	Hose nozzle cap	Cast iron	ASTM A126 CL. B
9	Hose nozzle	Bronze	ASTM B584
13	Stem	Steel	ASTM A576 GR. B
14	Drain valve screw	Stainless steel	ASTM A307
15	Upper valve plate*	Bronze	ASTM B584
16	Drain valve facing	Plastic	
17	Shoe gasket	Rubber	ASTM D2000
18	Main valve	Rubber	ASTM D2000
19	Shoe	Cast iron	ASTM A126 CL. B
20	Valve plate nut	Bronze	ASTM B584
21	Lower valve plate	Cast iron	ASTM A126 CL.B
23	Hose nozzle O-ring	Rubber	ASTM D2000 Neoprene
24	Seat ring	Bronze	ASTM B584
25	Seat ring gasket	Copper	ASTM A372
31	Oil screw	Brass	ASTM B36
31B	O-ring (for oil screw)	Rubber	ASTM D2000 BUNA-N
36	Nozzle cap chain	Steel	Plated
37	Barrel flange bolt and nut	Steel	ASTM A307 Plated
38	Barrel flange gasket	Rubber	ASTM D2000
39	Shoe bolt and nut	Steel	ASTM A307 Plated
40	Upper barrel	Cast iron	ASTM A126 CL. B
41	Lower barrel	Cast iron	ASTM A126 CL. B
42	O-ring	Rubber	ASTM D2000
44	Valve nut washer	Stainless steel	ASTM A276
45	Valve nut seal	Rubber	ASTM D2000
46	Nozzle lock	Stainless steel	ASTM A276
47	Hose nozzle gasket	Rubber	ASTM D2000 Neoprene

* Includes items #14 and #16.

For pre-1986 models refer to parts drawing on page 9.35.

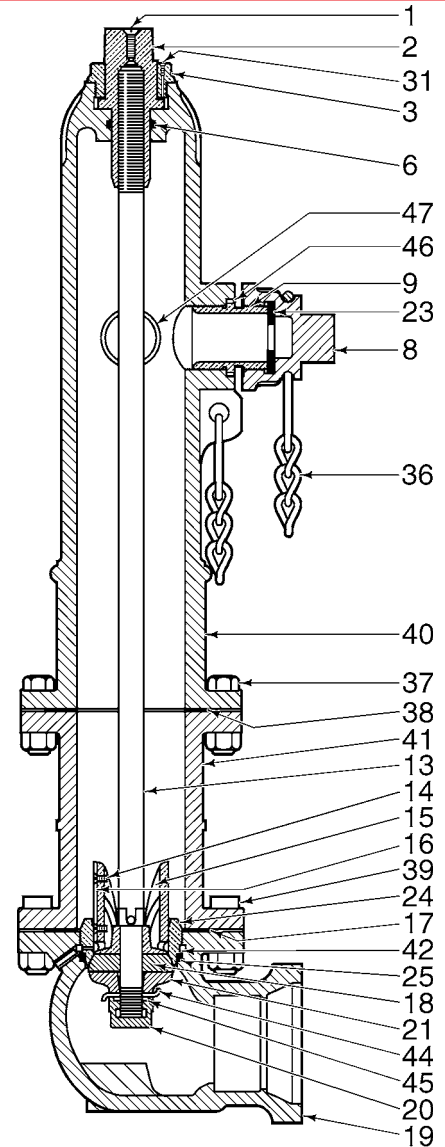

A-312

A-312 Operating wrench--- operates nozzle caps, pin and lug type hose couplings, hydrant operating nut and hold down nut.



A-347

A-347 Seat wrench--- Adjustable, used to remove main valve and seat ring from ground line level.



A-316

A-316 Nozzle wrench--- Used to remove and install threaded in hose and pumper nozzles.



A-317

A-317 Nozzle lock installation tool--- Used to install nozzle locking device.

Rev. 8-04

- ❑ Catalog numbers---
A-412 2-1/8" main valve opening one way
 (one 2-1/2" hose nozzle) non-locking lid
- ❑ Meets all applicable parts of ANSI/AWWA C502 Standard
- ❑ Flush type dry barrel design
- ❑ Compression type main valve closes with pressure
- ❑ Cast iron flush box with non-locking lid
- ❑ Operating nut available in wide variety of shapes and sizes
- ❑ Field replaceable hose nozzles
- ❑ Hose nozzles have large radius, full flow openings for low friction loss
- ❑ Contoured shoe is designed for full flow
- ❑ Dual bronze drain valves provide effective barrel drainage
- ❑ 150 psig (1034 kPa) maximum working pressure,
 300 psig (2068 kPa) test pressure

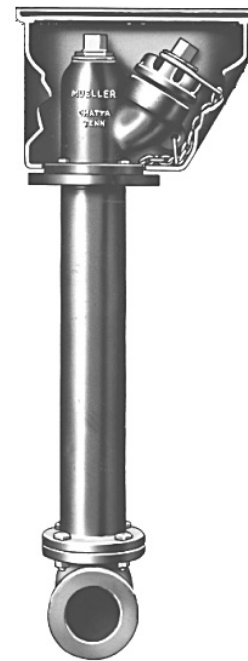

Dimensions

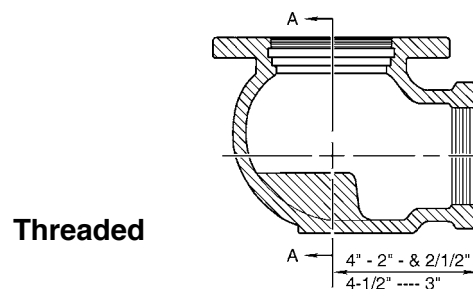
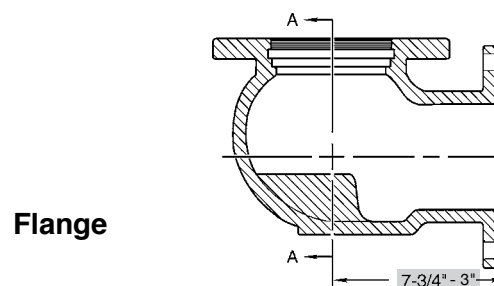
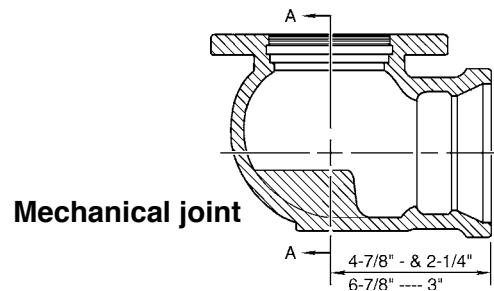
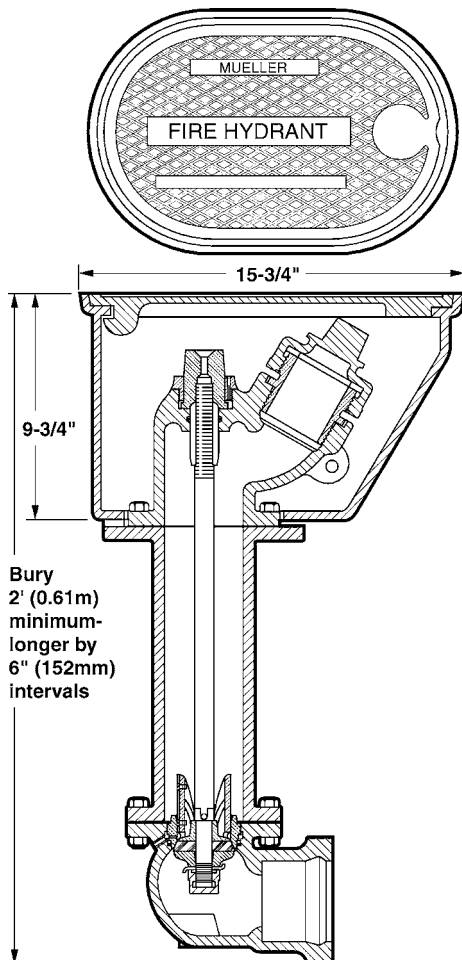

MUELLER® 2-1/8" FLUSH TYPE FIRE HYDRANT

MUELLER 2-1/8" Flush Type Fire Hydrant

Cat. part no.	Description	Material	Material standard
1	Oil screw for operating nut	Brass	ASTM B36
2	Operating nut	Bronze	ASTM B584
3	Hold down nut	Bronze	ASTM B584
6	Operating nut O-ring	Rubber	ASTM D2000 BUNA N
8	Hose nozzle cap	Cast iron	ASTM A126 CL. B
9	Hose nozzle	Bronze	ASTM B584
14	Drain valve screw	Stainless steel	ASTM A307
15	Upper valve plate*	Bronze	ASTM B584
16	Drain valve facing	Plastic	
17	Shoe gasket	Rubber	ASTM D2000
18	Main valve	Rubber	ASTM D2000
19	Shoe	Cast iron	ASTM A126 CL. B
20	Valve plate nut (for use on pre-1986 models; 1986 and newer models use numbers 43, 44, 45)	Bronze	ASTM B584
21	Lower valve plate	Cast iron	ASTM A126 CL.B
23	Hose nozzle gasket	Rubber	ASTM ASTM D2000 Neoprene
24	Seat ring	Bronze	ASTM B584
25	Seat ring gasket	Copper	ASTM A372
31	Oil screw	Brass	ASTM B36
38	Barrel flange gasket	Rubber	ASTM D2000
39	Shoe bolt and nut	Steel	ASTM A307 Plated
42	O-ring	Rubber	ASTM D2000
43	Cap nut (for use on 1986 and newer models with numbers 44 and 45; not shown)	Bronze	ASTM B584
44	Valve nut washer (used with numbers 43 and 45; not shown)	Stainless steel	ASTM A276
45	Valve nut seal (used with numbers 43 and 44; not shown)	Rubber	ASTM D2000
46	Nozzle lock	Stainless steel	ASTM A276
47	Upper barrel	Cast iron	ASTM A126 CL. B
48	Flush box	Cast iron	ASTM A126 CL. B
49	Flush box lid (non-locking)	Cast iron	ASTM A126 CL.B
50	Cap screw	Steel	Electrogalvanized
51	Stem	Steel	ASTM A576 GR. B
52	Lower barrel	Cast iron	ASTM A126 CL. B

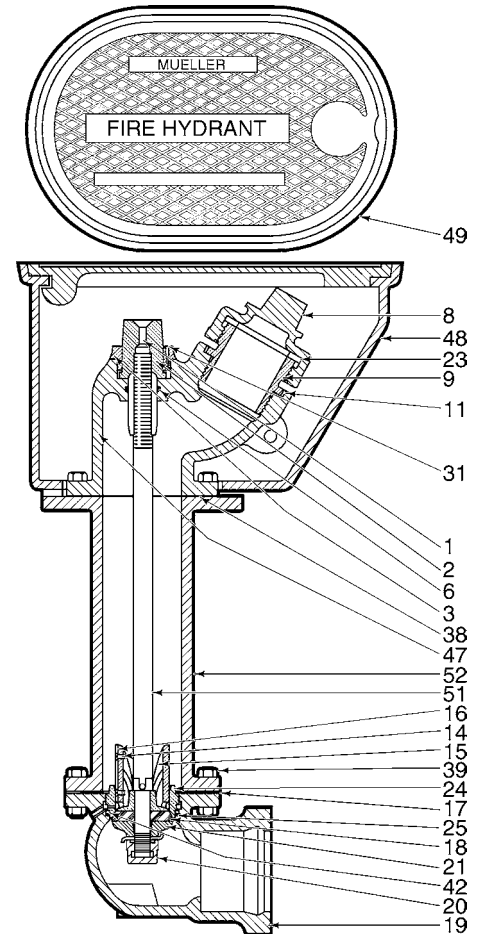

*Includes items 14 and 16.

A-313 Operating wrench--- Operates nozzle caps, pin and lug type hose couplings, hydrant operating nut and hold down nut.



A-313



A-344

A-344 Seat wrench--- Adjustable, used to remove main valve and seat ring from ground line level.



A-316

A-316 Nozzle wrench--- Used to remove and install threaded in hose and pumper nozzles.



A-317

A-317 Nozzle lock installation tool--- Used to install nozzle locking device.

When ordering Fire Hydrants, specify the following:

1. Quantity

If more than one size, quantity of each.

2. Size of main valve opening

3. Catalog number of Fire Hydrant

4. Nozzle arrangement

The catalog number indicates the normal arrangements of hose and pumper nozzles. If a different arrangement is desired, specify the size and number of hose and pumper nozzles required.

5. Depth of trench or bury

Distance from ground line to bottom of connecting pipe. "Trench" and "ditch" are the same as "bury". "Cover" is the distance from the ground to the top of the connecting pipe.

6. Size of inlet connection

7. Type of inlet connection

8. Size and shape of operating nut

National Standard is 1-1/2" pentagon, measured from point to opposite flat. Square and hexagon or other sizes of pentagon can also be furnished. Size is determined by measuring from flat to opposite flat on square and hexagon, and from point to opposite flat on pentagon. Measurements must be taken at base of nut.

9. Direction of opening

Open left (counter-clockwise) or open right (clockwise).

10. Hose nozzle threading

Send a sample of the male coupling on hydrant nozzle to show threads desired, **EXCEPT** in the following cases **(a)** if using National Standard, specify accordingly **(b)** if we have previously furnished hydrants to the same location and there is no change (complete records are kept on file in our Engineering Department for reference).

11. Pumper nozzle threading

Same instructions as 10 above.

12. Color

Unless otherwise specified, the hydrant will be enameled above ground with fire hydrant red. When so ordered, we will enamel any color (or colors) specified to match your existing standards.

When ordering parts, specify the following:

1. Year date shown on hydrant barrel

- 2. Part number and name
- 3. Size and catalog number of hydrant
- 4. Direction of opening
- 5. Depth of bury
- 6. Bonnet markings
- 7. Type of inlet connection
- 8. Nozzle specifications (see steps 10 and 11 above)

Contact your MUELLER Distributor or MUELLER Customer Service Center for repair parts for discontinued MUELLER Fire Hydrants.

National Standard hose coupling thread specifications

A. Nominal inside diameter of nozzle		2-1/2"	3"	3-1/2"	4"	4-1/2"
Number of threads per inch		7-1/2	6	6	4	4
B. Major diameter nozzle thread	Max.	3.0686	3.6239	4.2439	5.0109	5.7609
	Min.	3.0366	3.5879	4.2079	4.9609	5.7109
C. Pitch diameter nozzle thread	Max.	2.9820	3.5156	4.1356	4.8485	5.5985
	Min.	2.9660	3.4976	4.1176	4.8235	5.5735
D. Minor diameter nozzle thread	Max.	2.8954	3.4073	4.0273	4.6861	5.4361
E. Diameter pilot nozzle		2.850	3.354	3.973	4.610	5.357
*F. Length of thread-nozzle		1"	1-1/8"	1-1/8"	1-1/4"	1-1/4"
G. Face to start of second turn		1/4"	5/16"	5/16"	7/16"	7/16"
H. Major diameter cplg. thread	Min.	3.0836	3.6389	4.2639	5.0359	5.7859
	Max.	3.0130	3.5486	4.1736	4.8985	5.6485
I. Pitch diameter coupling thread	Min.	2.9970	3.5306	4.1556	4.8735	5.6235
	Max.	2.9424	3.4583	4.0833	4.7611	5.5111
J. Minor diameter coupling thread	Min.	2.9104	3.4223	4.0473	4.7111	5.4611
	Max.					
K. Depth of coupling		15/16"	1-1/16"	1-1/16"	1-3/16"	1-3/16"

* Manufacturers standard

NOTE: All dimensions are in inches and all dimensional data and tolerances are in accord with ANSI B26.

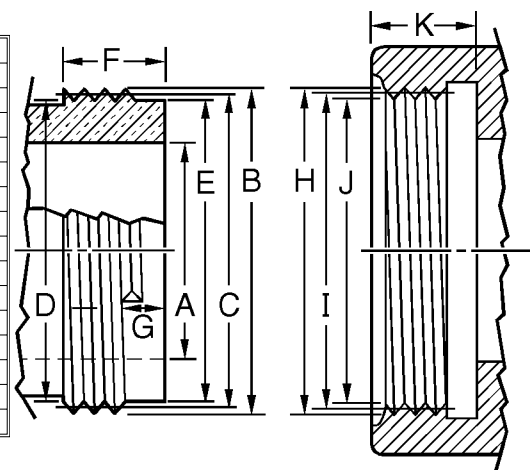

HYDRANT WITH BRASS SAFETY STEM COUPLING

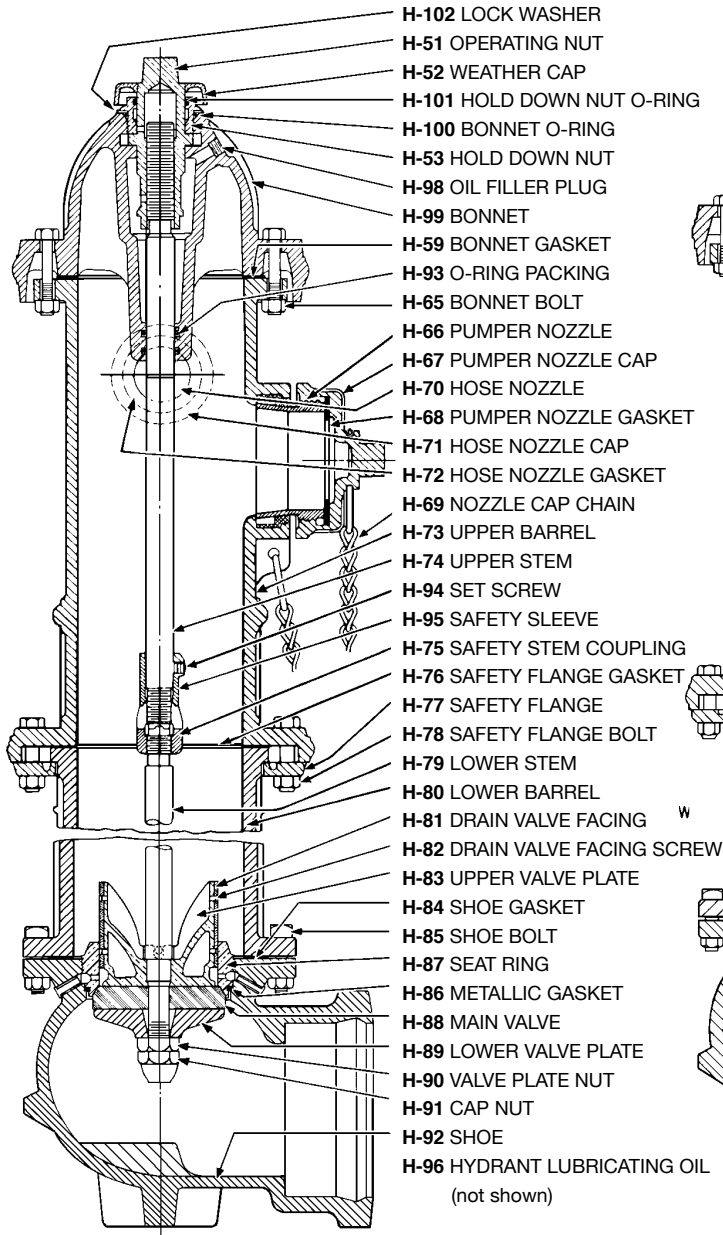

HYDRANT WITH STEEL SAFETY STEM COUPLING

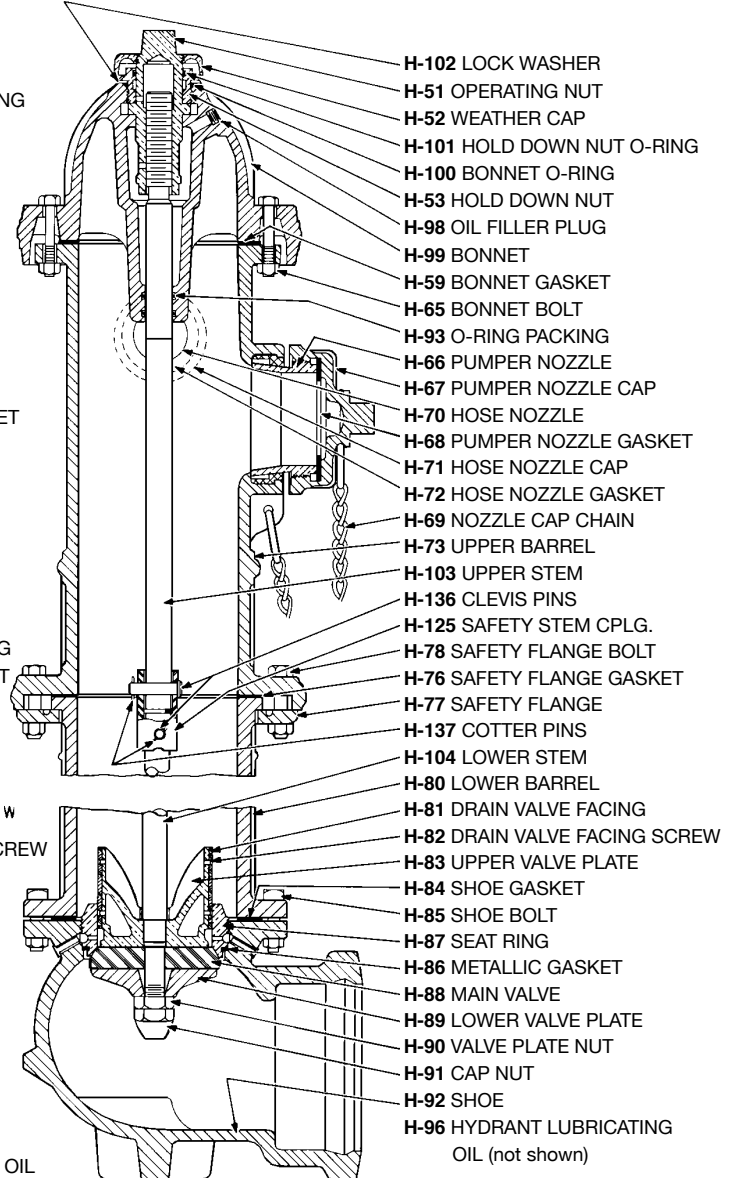

1934 THROUGH 1947

Bonnet section of hydrant with conventional packing and without oil filler plug in bonnet. All other parts same as on previous page.

Appearance same as 1948 through 1953 with filler plug. If nozzle chains are attached to eyebolt, bonnet is this style. Packing is conventional.

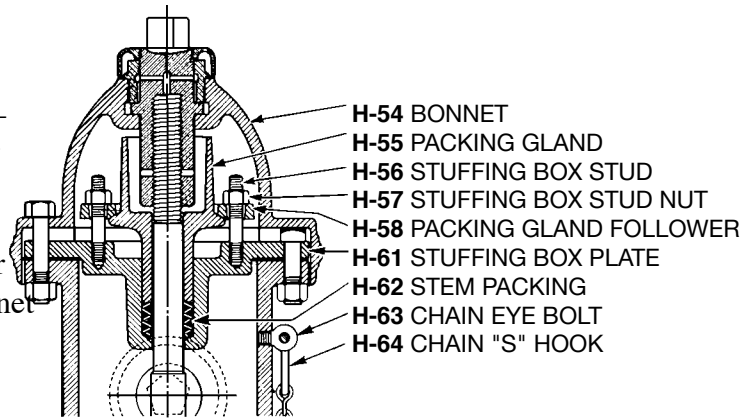

1948 THROUGH 1953

Bonnet section with O-ring seals and without oil filler plug in bonnet. All other parts same as drawing on previous page. Year date is marked on side of barrel.

No oil filler plug. Nozzle chains are attached below each nozzle. O-rings now used in place of conventional packing.

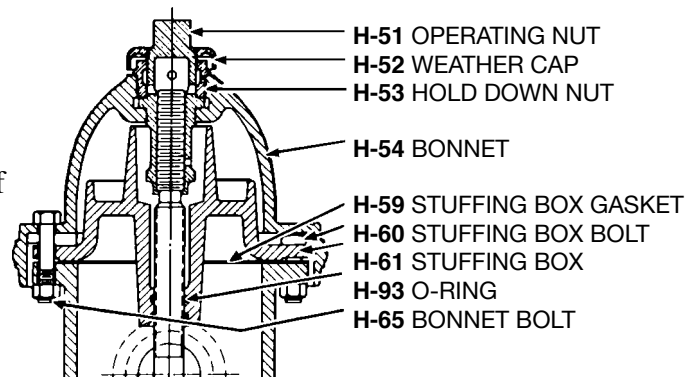

1954 THROUGH 1961

Bonnet section with O-ring seals and oil filler plug in bonnet. All other parts same as drawing on previous page. Year date is marked on side of barrel.

Oil reservoir changed in shape to allow addition of oil without disturbing bonnet. Oil filter plug in vertical position.

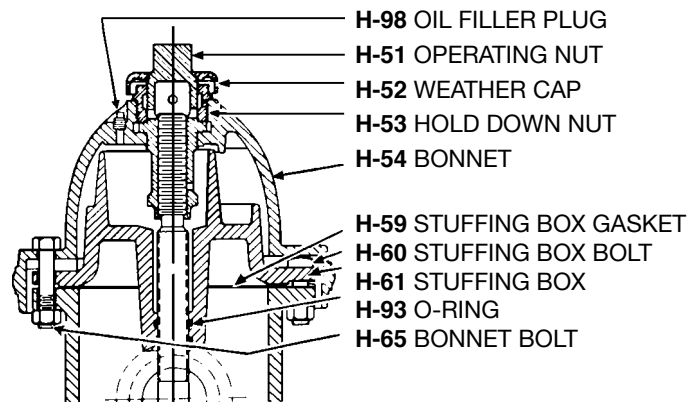

HYDRANT WITH SEALED OIL RESERVOIR - 1962 STYLE

Hydrant bonnet is marked SR on top of flange. Oil filler plug is set on an angle. Lock washer was added in 1965. Year date is marked on side of barrel.

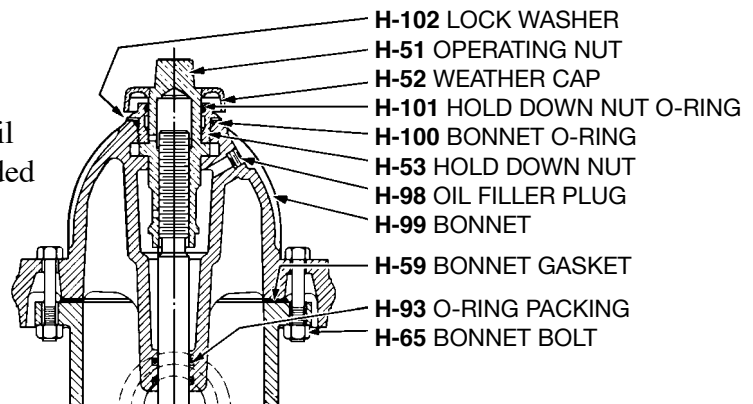

HYDRANT WITH STEEL SAFETY STEM COUPLING

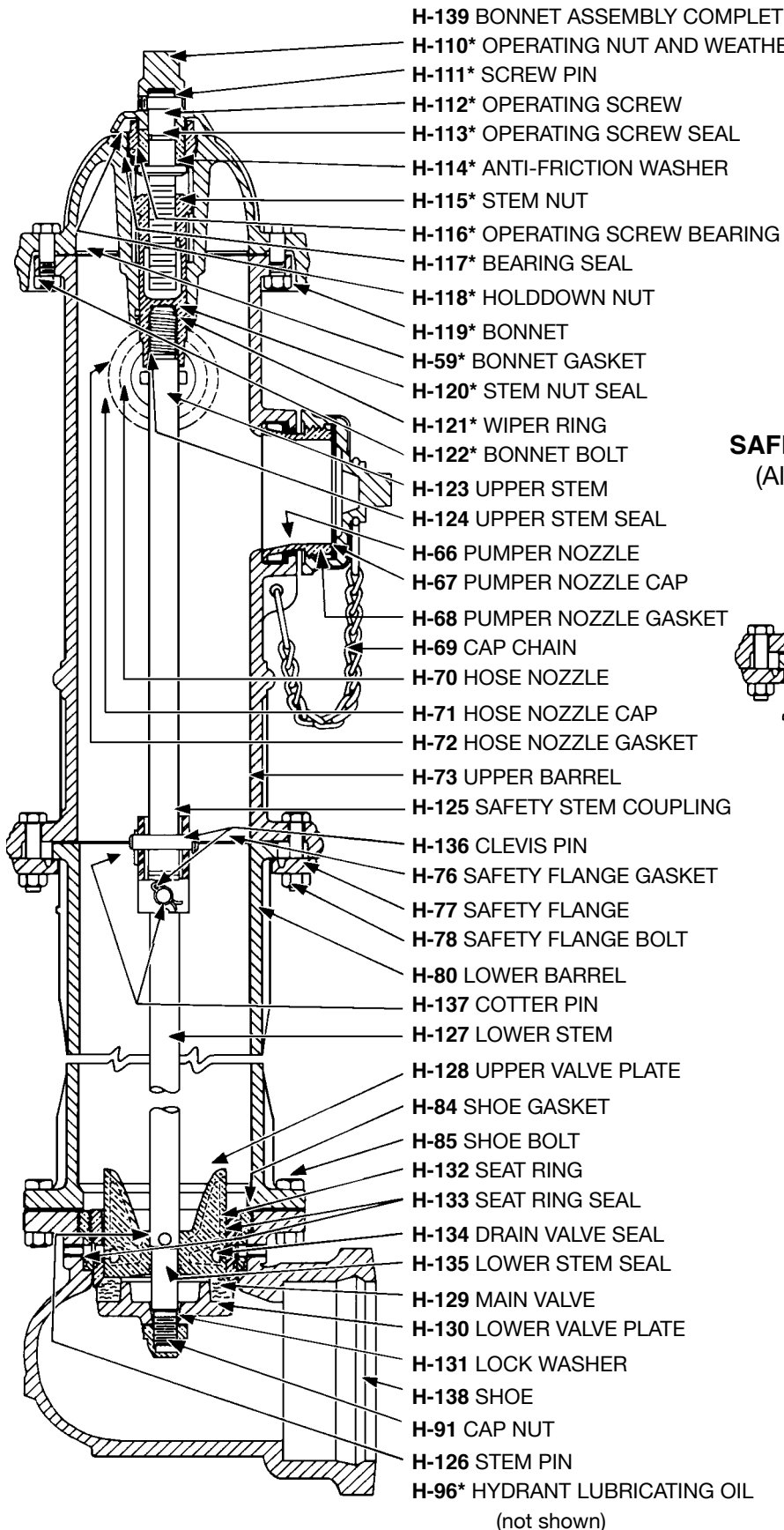

- H-139 BONNET ASSEMBLY COMPLETE (includes following*)
- H-110* OPERATING NUT AND WEATHER CAP
- H-111* SCREW PIN
- H-112* OPERATING SCREW
- H-113* OPERATING SCREW SEAL
- H-114* ANTI-FRICTION WASHER
- H-115* STEM NUT
- H-116* OPERATING SCREW BEARING
- H-117* BEARING SEAL
- H-118* HOLDDOWN NUT
- H-119* BONNET
- H-59* BONNET GASKET
- H-120* STEM NUT SEAL
- H-121* WIPER RING
- H-122* BONNET BOLT
- H-123 UPPER STEM
- H-124 UPPER STEM SEAL
- H-66 PUMPER NOZZLE
- H-67 PUMPER NOZZLE CAP
- H-68 PUMPER NOZZLE GASKET
- H-69 CAP CHAIN
- H-70 HOSE NOZZLE
- H-71 HOSE NOZZLE CAP
- H-72 HOSE NOZZLE GASKET
- H-73 UPPER BARREL
- H-125 SAFETY STEM COUPLING
- H-136 CLEVIS PIN
- H-76 SAFETY FLANGE GASKET
- H-77 SAFETY FLANGE
- H-78 SAFETY FLANGE BOLT
- H-80 LOWER BARREL
- H-137 COTTER PIN
- H-127 LOWER STEM
- H-128 UPPER VALVE PLATE
- H-84 SHOE GASKET
- H-85 SHOE BOLT
- H-132 SEAT RING
- H-133 SEAT RING SEAL
- H-134 DRAIN VALVE SEAL
- H-135 LOWER STEM SEAL
- H-129 MAIN VALVE
- H-130 LOWER VALVE PLATE
- H-131 LOCK WASHER
- H-138 SHOE
- H-91 CAP NUT
- H-126 STEM PIN
- H-96* HYDRANT LUBRICATING OIL
(not shown)

HYDRANT WITH CAST IRON SAFETY STEM COUPLING

(All other parts same as
drawing at left)

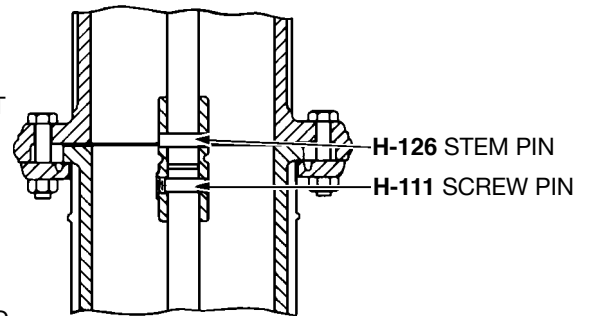

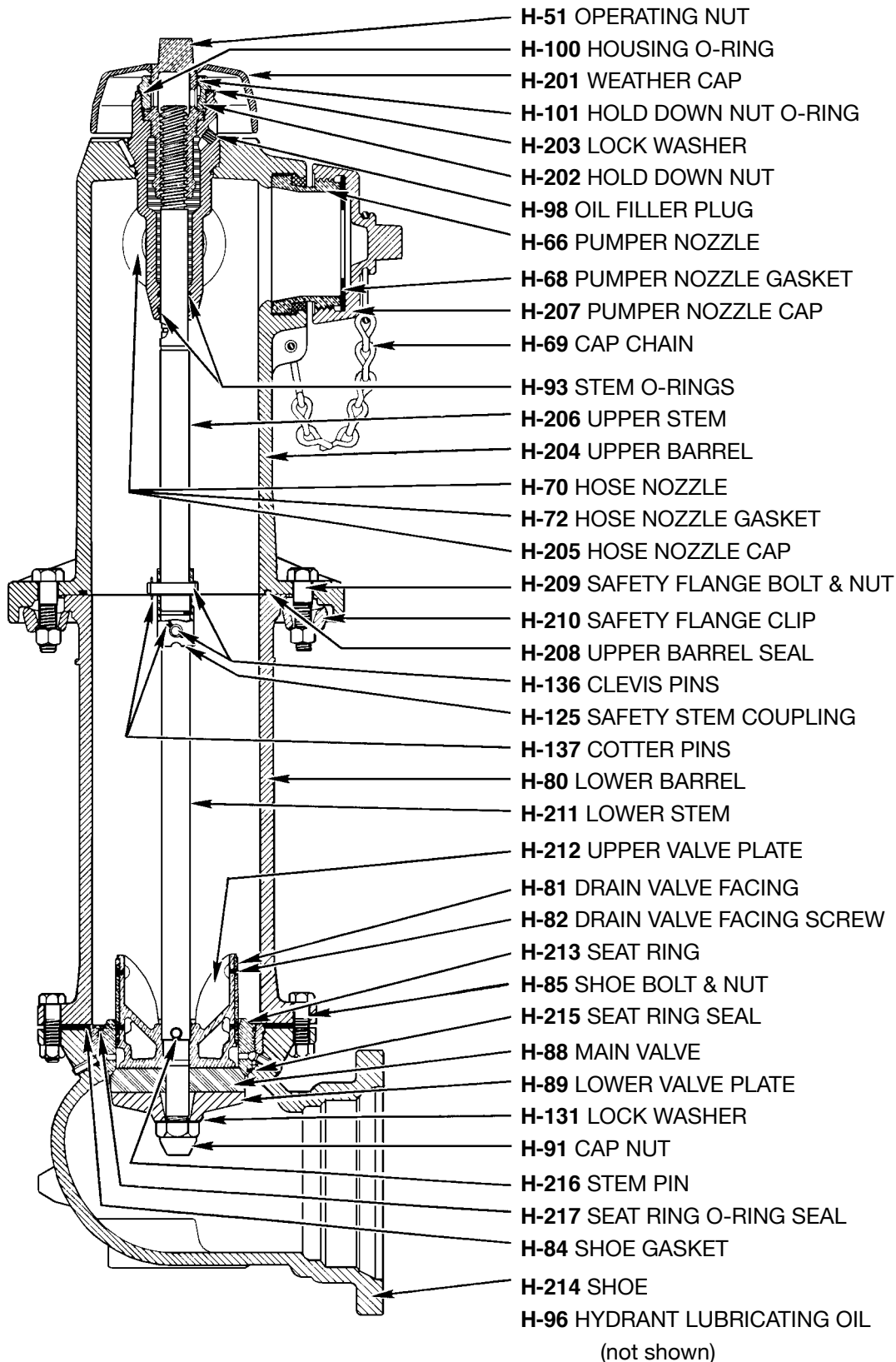

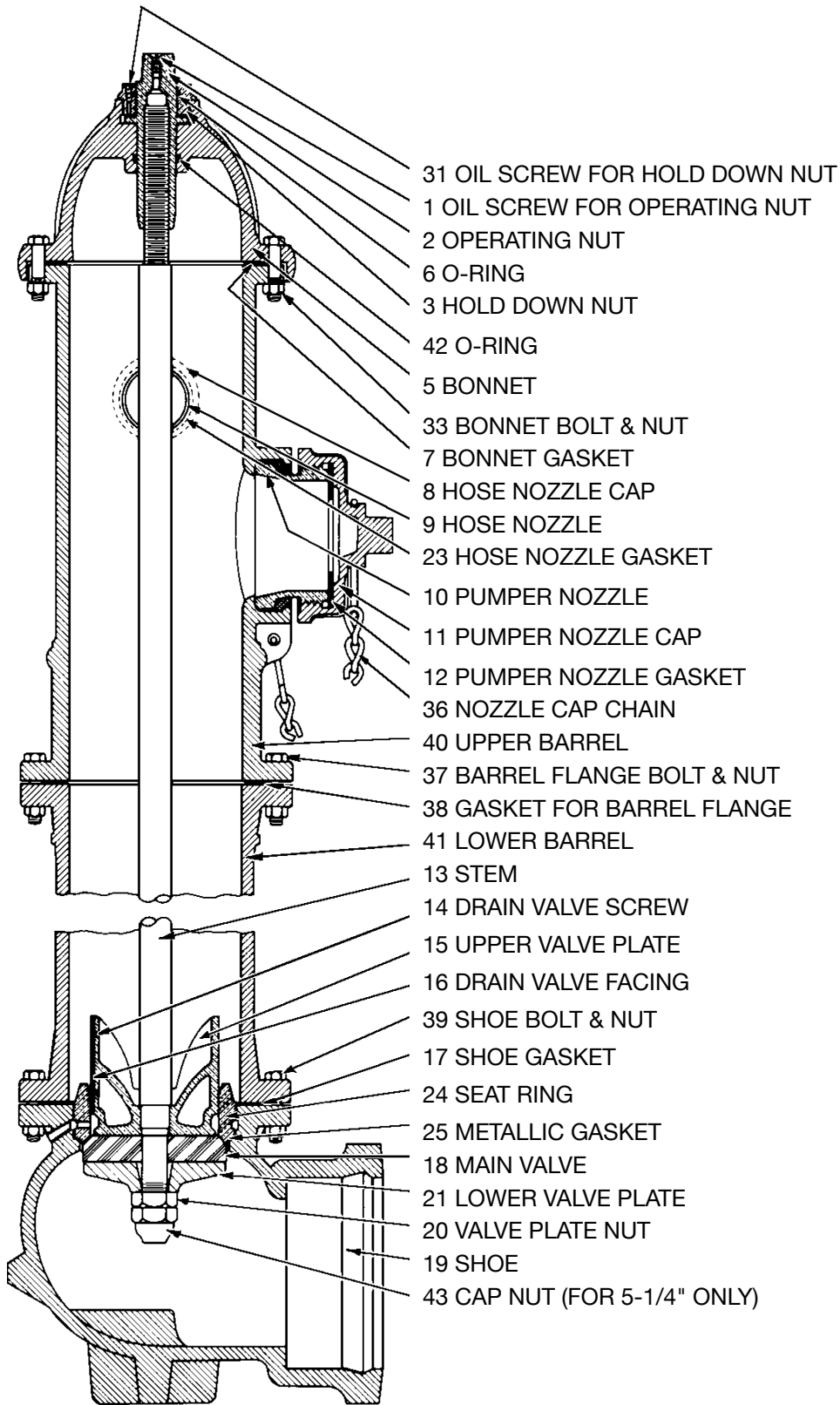

- 31 OIL SCREW FOR HOLD DOWN NUT
- 1 OIL SCREW FOR OPERATING NUT
- 2 OPERATING NUT
- 6 O-RING
- 3 HOLD DOWN NUT
- 42 O-RING
- 5 BONNET
- 33 BONNET BOLT & NUT
- 7 BONNET GASKET
- 8 HOSE NOZZLE CAP
- 9 HOSE NOZZLE
- 23 HOSE NOZZLE GASKET
- 10 PUMPER NOZZLE
- 11 PUMPER NOZZLE CAP
- 12 PUMPER NOZZLE GASKET
- 36 NOZZLE CAP CHAIN
- 40 UPPER BARREL
- 37 BARREL FLANGE BOLT & NUT
- 38 GASKET FOR BARREL FLANGE
- 41 LOWER BARREL
- 13 STEM
- 14 DRAIN VALVE SCREW
- 15 UPPER VALVE PLATE
- 16 DRAIN VALVE FACING
- 39 SHOE BOLT & NUT
- 17 SHOE GASKET
- 24 SEAT RING
- 25 METALLIC GASKET
- 18 MAIN VALVE
- 21 LOWER VALVE PLATE
- 20 VALVE PLATE NUT
- 19 SHOE
- 43 CAP NUT (FOR 5-1/4" ONLY)

MUELLER HI-FLO Wet Barrel Fire Hydrant

Cat. part no.	Description	Material	Material standard
1	Pumper nozzle cap gasket	Rubber	ASTM D2000
2	Pumper nozzle o-ring	Rubber	ASTM D2000
3	Cotter pin	Silicon bronze	
4	Anti-friction washer	Celcon	
5	Seat washer	Rubber	ASTM D2000
6	O-ring	Rubber	ASTM D2000
7	Stem	Bronze	ASTM B584
8	Stuffing box o-ring	Rubber	ASTM D2000
9	Stuffing box	Bronze	ASTB B584
10	Barrel o-ring	Rubber	ASTM D2000
11	Hose nozzle cap gasket	Rubber	ASTM D2000
12	Hose nozzle o-ring	Rubber	ASTM D2000
13	Cotter pin	Silicon bronze	Silicon bronze
14	Anti-friction washer	Celcon	
15	Seat washer	Rubber	ASTM D2000
16	O-ring	Rubber	ASTM D2000
17	Stem	Bronze	ASTM B584
18	Stuffing box o-ring	Rubber	ASTM D2000
19	Stuffing box	Bronze	ASTM B584
20	Barrel o-ring	Rubber	ASTM D2000
21	Retaining ring	Steel	
-	Rivet (not illustrated)	Copper	

