

CHAPTER 52

FIRE AND SMOKE MANAGEMENT

Fire Management	52.1	Zone Smoke Control	52.11
Smoke Movement	52.2	Computer Analysis for Pressurization Systems	52.12
Smoke Management	52.4	Smoke Management in Large Spaces	52.12
Smoke Control System Design	52.6	Tenability Systems	52.17
Fire and Smoke Dampers	52.8	Acceptance Testing	52.17
Pressurized Stairwells	52.9	Special Inspector	52.17
Elevators	52.11	Extraordinary Incidents	52.18

IN building fires, smoke often flows to locations remote from the fire, threatening life and damaging property. Stairwells and elevators frequently fill with smoke, thereby blocking or inhibiting evacuation. Smoke causes the most deaths in fires. **Smoke** includes airborne solid and liquid particles and gases produced when a material undergoes pyrolysis or combustion, together with air that is entrained or otherwise mixed into the mass.

The idea of using pressurization to prevent smoke infiltration of stairwells began to attract attention in the late 1960s. This concept was followed by the idea of the pressure sandwich (i.e., venting or exhausting the fire floor and pressurizing the surrounding floors). Frequently, a building’s ventilation system is used for this purpose. **Smoke control** systems use fans to pressurize appropriate areas to limit smoke movement in fire situations. **Smoke management** systems include pressurization and all other methods that can be used singly or in combination to modify smoke movement.

This chapter discusses fire protection and smoke control systems in buildings as they relate to HVAC. For a more complete discussion, refer to *Principles of Smoke Management* (Klote and Milke 2002). National Fire Protection Association (NFPA) *Standard 204* provides information about venting large industrial and storage buildings. For further information, refer to NFPA *Standards 92A* and *92B*.

The objective of fire safety is to provide some degree of protection for a building’s occupants, the building and property inside it, and neighboring buildings. Various forms of analysis have been used to quantify protection. Specific life safety objectives differ with occupancy; for example, nursing home requirements are different from those for office buildings.

Two basic approaches to fire protection are (1) to prevent fire ignition and (2) to manage fire effects. [Figure 1](#) shows a decision

tree for fire protection. Building occupants and managers have the primary role in preventing fire ignition. The building design team may incorporate features into the building to assist the occupants and managers in this effort. Because it is impossible to prevent fire ignition completely, managing fire effect has become significant in fire protection design. Examples include compartmentation, suppression, control of construction materials, exit systems, and smoke management. The *Fire Protection Handbook* (NFPA 2003) and *Smoke Movement and Control in High-Rise Buildings* (Tamura 1994) contain detailed fire safety information.

Historically, fire safety professionals have considered the HVAC system a potentially dangerous penetration of natural building membranes (walls, floors, etc.) that can readily transport smoke and fire. For this reason, HVAC has traditionally been shut down when fire is discovered; this prevents fans from forcing smoke flow, but does not prevent ducted smoke movement caused by buoyancy, stack effect, or wind. To solve the problem of smoke movement, methods of smoke control have been developed; however, smoke control should be viewed as only one part of the overall building fire protection system.

FIRE MANAGEMENT

Although most of this chapter discusses smoke management, fire management at HVAC penetrations is an additional concern for the HVAC engineer. The most efficient way to limit fire damage is through compartmentation. Fire-rated assemblies, such as the floor or walls, keep the fire in a given area for a specific period. However, fire can easily pass through openings for plumbing, HVAC ductwork, communication cables, or other services. Therefore, fire stop systems are installed to maintain the rating of the fire-rated assembly. The rating of a fire stop system depends on the number, size, and type of penetrations, and the construction assembly in which it is installed.

Performance of the entire fire stop system, which includes the construction assembly with its penetrations, is tested under fire conditions by recognized independent testing laboratories. ASTM *Standard E814* and UL *Standard 1479* describe ways to determine performance of **through-penetration fire stopping (TPFS)**.

TPFS is required by building codes under certain circumstances for specific construction types and occupancies. In the United States, model building codes require that most penetrations meet the ASTM E814 test standard. TPFS classifications are published by testing laboratories. Each classification is proprietary, and each applies to use with a specific set of conditions, so numerous types are usually required on any given project.

The construction manager and general contractor, not the architects and engineers, make work assignments. Sometimes they assign fire stopping to the discipline making the penetration; other times, they assign it to a specialty fire-stopping subcontractor. The

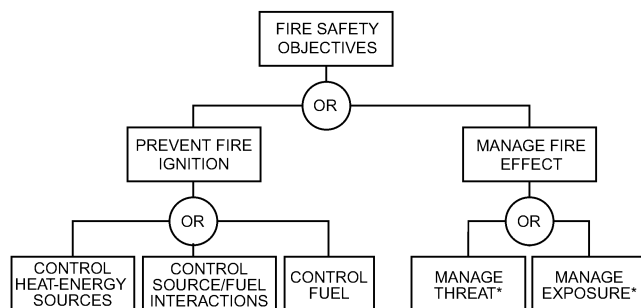

*Note: Smoke management is one of many fire protection tools that can be used to help manage the threat and exposure of fire.

Fig. 1 Simplified Fire Protection Decision Tree

The preparation of this chapter is assigned to TC 5.6, Control of Fire and Smoke.

Construction Specifications Institute (CSI) assigns fire-stopping specifications to Division 7, which

- Encourages continuity of fire-stopping products on the project by consolidating their requirements (e.g., TPFS, expansion joint fire stopping, floor-to-wall joint fire stopping, etc.)
- Maintains flexibility of work assignments for the general contractor and construction manager
- Encourages prebid discussions between the contractor and subcontractors regarding appropriate work assignments

SMOKE MOVEMENT

A smoke control system must be designed so that it is not overpowered by the driving forces that cause smoke movement, which include stack effect, buoyancy, expansion, wind, and the HVAC system. During a fire, smoke is generally moved by a combination of these forces.

Stack Effect

When it is cold outside, air tends to move upward within building shafts (e.g., stairwells, elevator shafts, dumbwaiter shafts, mechanical shafts, mail chutes). This **normal stack effect** occurs because air in the building is warmer and less dense than outside air. Normal stack effect is large when outside temperatures are low, especially in tall buildings. However, normal stack effect can exist even in a one-story building.

When outside air is warmer than building air, there is a natural tendency for downward airflow, or **reverse stack effect**, in shafts. At standard atmospheric pressure, the pressure difference caused by either normal or reverse stack effect is expressed as

$$\Delta p = 7.64 \left(\frac{1}{T_o} - \frac{1}{T_i} \right) h \tag{1}$$

where

- Δp = pressure difference, in. of water
- T_o = absolute temperature of outside air, °R
- T_i = absolute temperature of air inside shaft, °R
- h = distance above neutral plane, ft

For a building 200 ft tall with a neutral plane at midheight, an outside temperature of 0°F (460°R), and an inside temperature of 70°F (530°R), the maximum pressure difference from stack effect is 0.22 in. of water. This means that, at the top of the building, pressure inside a shaft is 0.22 in. of water greater than the outside pressure. At the base of the building, pressure inside a shaft is 0.22 in. of water

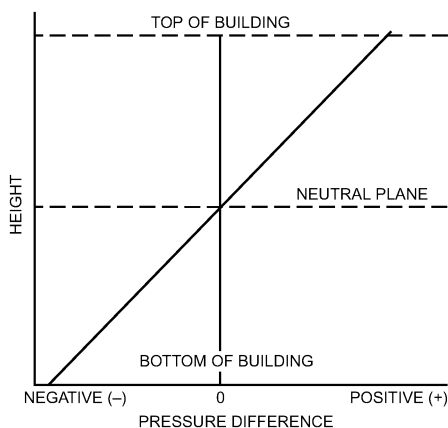

Fig. 2 Pressure Difference Between a Building Shaft and the Outside Caused by Normal Stack Effect

lower than the outside pressure. **Figure 2** diagrams the pressure difference between a building shaft and the outside. A positive pressure difference indicates that shaft pressure is higher than the outside pressure, and a negative pressure difference indicates the opposite. **Figure 3** illustrates air movement in buildings caused by both normal and reverse stack effect.

Figure 4 can be used to determine the pressure difference caused by stack effect. For normal stack effect, $\Delta p/h$ is positive, and the pressure difference is positive above the neutral plane and negative below it. For reverse stack effect, $\Delta p/h$ is negative, and the pressure difference is negative above the neutral plane and positive below it.

In unusually tight buildings with exterior stairwells, Klotz (1980) observed reverse stack effect even with low outside air temperatures. In this situation, the exterior stairwell temperature is considerably lower than the building temperature. The stairwell represents the cold column of air, and other shafts within the building represent the warm columns of air.

If leakage paths are uniform with height, the neutral plane is near the midheight of the building. However, when the leakage paths are not uniform, the location of the neutral plane can vary considerably, as in the case of vented shafts. McGuire and Tamura (1975) provide methods for calculating the location of the neutral plane for some vented conditions.

Smoke movement from a building fire can be dominated by stack effect. In a building with normal stack effect, the existing air currents (as shown in **Figure 3**) can move smoke considerable distances from the fire origin. If the fire is below the neutral plane, smoke moves

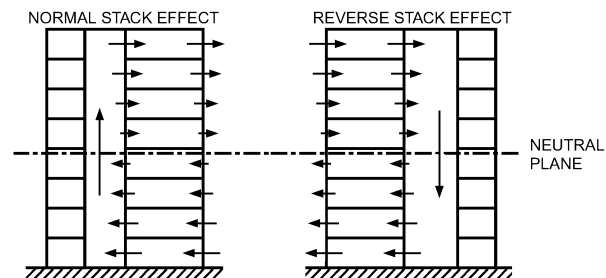

Note: Arrows indicate direction of air movement.

Fig. 3 Air Movement Caused by Normal and Reverse Stack Effect

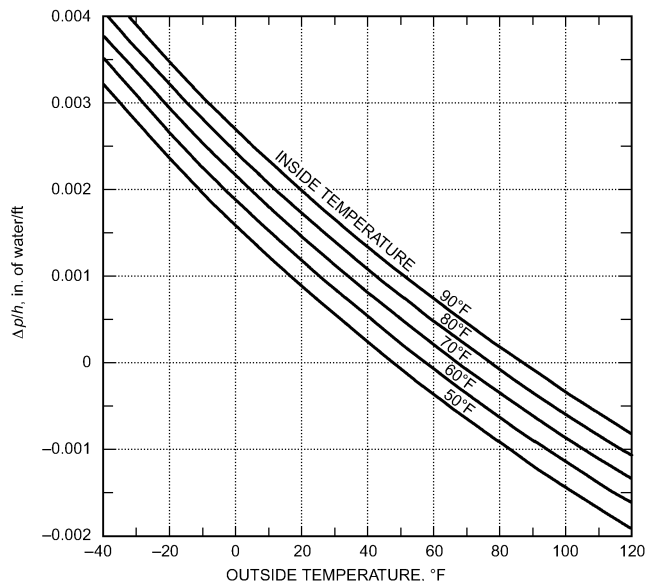

Fig. 4 Pressure Difference Caused by Stack Effect

with building air into and up the shafts. This upward smoke flow is enhanced by buoyancy forces due to the temperature of the smoke. Once above the neutral plane, smoke flows from the shafts into the upper floors of the building. If leakage between floors is negligible, floors below the neutral plane (except the fire floor) remain relatively smoke-free until more smoke is produced than can be handled by stack effect flows.

Smoke from a fire located above the neutral plane is carried by building airflow to the outside through exterior openings in the building. If leakage between floors is negligible, all floors other than the fire floor remain relatively smoke-free until more smoke is produced than can be handled by stack effect flows. When leakage between floors is considerable, smoke flows to the floor above the fire floor.

Air currents caused by reverse stack effect (see Figure 3) tend to move relatively cool smoke down. In the case of hot smoke, buoyancy forces can cause smoke to flow upward, even during reverse stack effect conditions.

Buoyancy

High-temperature smoke has buoyancy because of its reduced density. At sea level, the pressure difference between a fire compartment and its surroundings can be expressed as follows:

$$\Delta p = 7.64 \left(\frac{1}{T_s} - \frac{1}{T_f} \right) h \tag{2}$$

where

- Δp = pressure difference, in. of water
- T_s = absolute temperature of surroundings, °R
- T_f = average absolute temperature of fire compartment, °R
- h = distance above neutral plane, ft

The pressure difference caused by buoyancy can be obtained from Figure 5 for surroundings at 68°F (328°R). The neutral plane is the plane of equal hydrostatic pressure between the fire compartment and its surroundings. For a fire with a fire compartment temperature at 1470°F (1930°R), the pressure difference 5 ft above the neutral plane is 0.052 in. of water. Fang (1980) studied pressures caused by room fires during a series of full-scale fire tests. During these tests, the maximum pressure difference reached was 0.064 in. of water across the burn room wall at the ceiling.

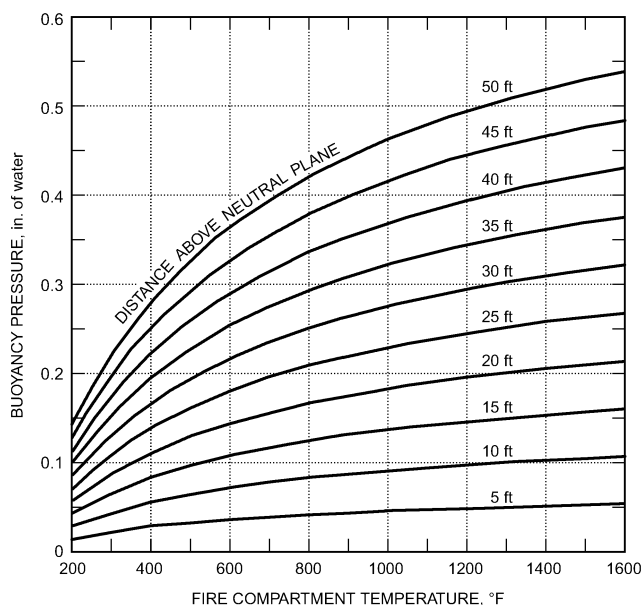

Fig. 5 Pressure Difference Caused by Buoyancy

Much larger pressure differences are possible for tall fire compartments where the distance h from the neutral plane can be larger. If the fire compartment temperature is 1290°F (1750°R), the pressure difference 35 ft above the neutral plane is 0.35 in. of water. This is a large fire, and the pressures it produces are beyond present smoke control methods. However, the example illustrates the extent to which Equation (2) can be applied.

In sprinkler-controlled fires, the temperature in the fire room remains at that of the surroundings except for a short time before sprinkler activation. Sprinklers are activated by the ceiling jet, a thin (2 to 4 in.) layer of hot gas under the ceiling. The maximum temperature of the ceiling jet depends on the location of the fire, the activation temperature of the sprinkler, and the thermal lag of the sprinkler heat-responsive element. For most residential and commercial applications, the ceiling jet is between 180 and 300°F. In Equation (2), T_f is the average temperature of the fire compartment. For a sprinkler-controlled fire,

$$T_f = \frac{T_s(H - H_j) + T_j H_j}{H} \tag{3}$$

where

- H = floor-to-ceiling height, ft
- H_j = thickness of ceiling jet, ft
- T_j = absolute temperature of ceiling jet, °R

For example, for $H = 96$ in., $H_j = 4$ in., $T_s = 68 + 460 = 528^\circ\text{R}$, and $T_j = 300 + 460 = 760^\circ\text{R}$,

$$T_f = [528(96 - 4) + 760 \times 4] / 96 = 538^\circ\text{R} \text{ or } 78^\circ\text{F}$$

In Equation (2), this results in a pressure difference of 0.002 in. of water, which is insignificant for smoke control applications.

Expansion

Energy released by a fire can also move smoke by expansion. In a fire compartment with only one opening to the building, building air will flow in, and hot smoke will flow out. Neglecting the added mass of the fuel, which is small compared to airflow, the ratio of volumetric flows can be expressed as a ratio of absolute temperatures:

$$\frac{Q_{out}}{Q_{in}} = \frac{T_{out}}{T_{in}} \tag{4}$$

where

- Q_{out} = volumetric flow rate of smoke out of fire compartment, cfm
- Q_{in} = volumetric flow rate of air into fire compartment, cfm
- T_{out} = absolute temperature of smoke leaving fire compartment, °R
- T_{in} = absolute temperature of air into fire compartment, °R

For smoke at 1290°F (1750°R) and entering air at 67°F (527°R), the ratio of volumetric flows is 3.32. Note that absolute temperatures are used in the calculation. In such a case, if air enters the compartment at 3000 cfm, then smoke flows out at 9960 cfm, with the gas expanding to more than three times its original volume.

For a fire compartment with open doors or windows, the pressure difference across these openings caused by expansion is negligible. However, for a tightly sealed fire compartment, the pressure differences from expansion may be important.

Wind

Wind can have a pronounced effect on smoke movement within a building. The pressure wind exerts on a surface can be expressed as

$$p_w = 0.00643 C_w \rho_o V^2 \tag{5}$$

where

- p_w = pressure exerted by wind, in. of water
- C_w = pressure coefficient, dimensionless

$$\rho_o = \text{outside air density, lb}_m/\text{ft}^3$$

$$V = \text{wind velocity, mph}$$

The pressure coefficients C_w are in the range of -0.8 to 0.8 , with positive values for windward walls and negative values for leeward walls. The pressure coefficient depends on building geometry and varies locally over the wall surface. In general, wind velocity increases with height from the surface of the earth. Houghton and Caruther (1976), MacDonald (1975), Sachs (1972), and Simiu and Scanlan (1978) give detailed information concerning wind velocity variations and pressure coefficients. Shaw and Tamura (1977) developed specific information about wind data with respect to air infiltration in buildings.

With a pressure coefficient of 0.8 and air density of $0.075 \text{ lb}_m/\text{ft}^3$, a 35 mph wind produces a pressure on a structure of 0.47 in. of water. The effect of wind on air movement within tightly constructed buildings with all exterior doors and windows closed is slight. However, wind effects can be important for loosely constructed buildings or for buildings with open doors or windows. Usually, the resulting airflows are complicated, and computer analysis is required.

Frequently, a window breaks in the fire compartment. If the window is on the leeward side of the building, the negative pressure caused by the wind vents the smoke from the fire compartment. This reduces smoke movement throughout the building. However, if the broken window is on the windward side, wind forces the smoke throughout the fire floor and to other floors, which endangers the lives of building occupants and hampers fire fighting. Wind-induced pressure in this situation can be large and can dominate air movement throughout the building.

HVAC Systems

Before methods of smoke control were developed, HVAC systems were shut down when fires were discovered because the systems frequently transported smoke during fires.

In the early stages of a fire, the HVAC system can aid in fire detection. When a fire starts in an unoccupied portion of a building, the system can transport the smoke to a space where people can smell it and be alerted to the fire. However, as the fire progresses, the system transports smoke to every area it serves, thus endangering life in all those spaces. The system also supplies air to the fire space, which aids combustion. Although shutting the system down prevents it from supplying air to the fire, it does not prevent smoke movement through the supply and return air ducts, air shafts, and other building openings because of stack effect, buoyancy, or wind.

SMOKE MANAGEMENT

In this chapter, smoke management includes all methods that can be used singly or in combination to modify smoke movement for the benefit of occupants or firefighters or for reducing property damage. Barriers, smoke vents, and smoke shafts are traditional methods of smoke management. The effectiveness of barriers is limited by the extent to which they are free of leakage paths. Smoke vents and smoke shafts are limited by the fact that smoke must be sufficiently buoyant to overcome any other driving forces that could be present. In the last few decades, fans have been used to overcome the limitations of traditional approaches. Compartmentation, dilution, pressurization, airflow, and buoyancy are used by themselves or in combination to manage smoke conditions in fire situations. These mechanisms are discussed in the following sections.

Compartmentation

Barriers with sufficient fire endurance to remain effective throughout a fire exposure have long been used to protect against fire spread. In this approach, walls, partitions, floors, doors, and other barriers provide some level of smoke protection to spaces remote from the fire. This section discusses passive compartmentation; using

compartmentation with pressurization is discussed in the section on Pressurization (Smoke Control). Many codes, such as NFPA *Standard* 101, provide specific criteria for construction of smoke barriers (including doors) and their smoke dampers. The extent to which smoke leaks through such barriers depends on the size and shape of the leakage paths in the barriers and the pressure difference across the paths.

Dilution Remote from Fire

Smoke dilution is sometimes referred to as **smoke purging**, **smoke removal**, **smoke exhaust**, or **smoke extraction**. Dilution can be used to maintain acceptable gas and particulate concentrations in a compartment subject to smoke infiltration from an adjacent space. It can be effective if the rate of smoke leakage is small compared to either the total volume of the safeguarded space or the rate of purging air supplied to and removed from the space. Also, dilution can be beneficial to the fire service for removing smoke after a fire has been extinguished. Sometimes, when doors are opened, smoke flows into areas intended to be protected. Ideally, the doors are only open for short periods during evacuation. Smoke that has entered spaces remote from the fire can be purged by supplying outside air to dilute the smoke.

The following is a simple analysis of smoke dilution for spaces in which there is no fire. Assume that at time zero ($\theta = 0$), a compartment is contaminated with some concentration of smoke and that no more smoke flows into the compartment or is generated within it. Also, assume that the contaminant is uniformly distributed throughout the space. The concentration of contaminant in the space can be expressed as

$$\frac{C}{C_o} = e^{-at} \quad (6)$$

The dilution rate can be determined from the following equation:

$$a = \frac{1}{t} \ln \left(\frac{C_o}{C} \right) \quad (7)$$

where

C_o = initial concentration of contaminant

C = concentration of contaminant at time θ

a = dilution rate, air changes per minute

t = time after smoke stops entering space or smoke production has stopped, min

e = base of natural logarithm (approximately 2.718)

Concentrations C_o and C must be expressed in the same units, but can be any units appropriate for the particular contaminant being considered.

McGuire et al. (1970) evaluated the maximum levels of smoke obscuration from a number of fire tests and a number of proposed criteria for tolerable levels of smoke obscuration. Based on this evaluation, they state that the maximum levels of smoke obscuration are greater by a factor of 100 than those relating to the limit of tolerance. Thus, they indicate that a space can be considered "reasonably safe" with respect to smoke obscuration if the concentration of contaminants in the space is less than about 1% of the concentration in the immediate fire area. This level of dilution increases visibility by about a factor of 100 (e.g., from 0.5 ft to 50 ft) and reduces the concentrations of toxic smoke components. Toxicity is a more complex problem, and no parallel statement has been made regarding dilution needed to obtain a safe atmosphere with respect to toxic gases.

In reality, it is impossible to ensure that the concentration of the contaminant is uniform throughout the compartment. Because of buoyancy, it is likely that higher concentrations are near the ceiling. Therefore, exhausting smoke near the ceiling and supplying air near the floor probably dilutes smoke even more quickly than indicated by Equation (7). Supply and exhaust points should be placed to

prevent supply air from blowing into the exhaust inlet, thereby short-circuiting the dilution.

Example 1. A space is isolated from a fire by smoke barriers and self-closing doors, so that no smoke enters the compartment when the doors are closed. When a door is opened, smoke flows through the open doorway into the space. If the door is closed when the contaminant in the space is 20% of the burn room concentration, what dilution rate is required to reduce the concentration to 1% of that in the burn room in 6 min?

The time $t = 6$ min and $C_o/C = 20$. From Equation (7), the dilution rate is about 0.5 air changes per minute, or 30 air changes per hour.

Caution about Dilution near Fire. Many people have unrealistic expectations about what dilution can accomplish in the fire space. Neither theoretical nor experimental evidence indicates that using a building's HVAC system for smoke dilution will significantly improve tenable conditions in a fire space. The exception is an unusual space where the fuel is such that fire size cannot grow above a specific limit; this occurs in some tunnels and underground transit situations. Because HVAC systems promote a considerable degree of air mixing in the spaces they serve and because very large quantities of smoke can be produced by building fires, it is generally believed that smoke dilution by an HVAC system in the fire space does not improve tenable conditions in that space. Thus, any attempt to improve hazard conditions in the fire space, or in spaces connected to the fire space by large openings, with smoke purging will be ineffective.

Pressurization (Smoke Control)

Systems that pressurize an area using mechanical fans are referred to as smoke control in this chapter and in NFPA *Standard 92A*. A pressure difference across a barrier can control smoke movement, as illustrated in [Figure 6](#). Within the barrier is a door. The high-pressure side of the door can be either a refuge area or an egress route. The low-pressure side is exposed to smoke from a fire. Airflow through gaps around the door and through construction cracks prevents smoke infiltration to the high-pressure side.

For smoke control analysis, the orifice equation can be used to estimate the flow through building flow paths:

$$Q = 776CA\sqrt{2\Delta p/\rho} \tag{8}$$

where

- Q = volumetric airflow rate, cfm
- C = flow coefficient
- A = flow area (leakage area), ft²
- Δp = pressure difference across flow path, in. of water
- ρ = density of air entering flow path, lb_m/ft³

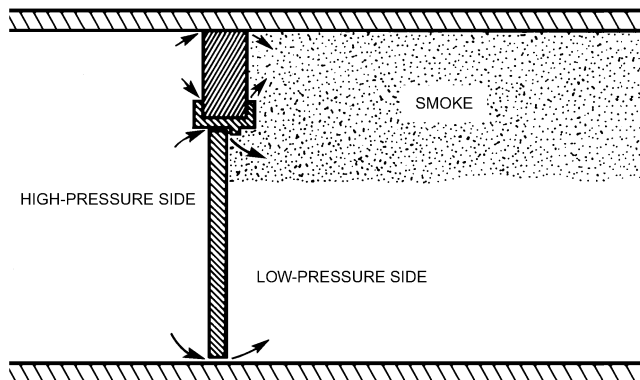

Fig. 6 Smoke Control System Preventing Smoke Infiltration to High-Pressure Side of Barrier

The flow coefficient depends on the geometry of the flow path, as well as on turbulence and friction. In the present context, the flow coefficient is generally 0.6 to 0.7. For $\rho = 0.075$ lb_m/ft³ and $C = 0.65$, Equation (8) can be expressed as

$$Q = 2610A\sqrt{\Delta p} \tag{9}$$

The flow area is frequently the same as the cross-sectional area of the flow path. A closed door with a crack area of 0.11 ft² and a pressure difference of 0.01 in. of water has an air leakage rate of approximately 29 cfm. If the pressure difference across the door is increased to 0.30 in. of water, the flow is 157 cfm.

Frequently, in field tests of smoke control systems, pressure differences across partitions or closed doors have fluctuated by as much as 0.02 in. of water. These fluctuations have generally been attributed to wind, although they could have been due to the HVAC system or some other source. To control smoke movement, the pressure difference produced by a smoke control system must be large enough to overcome pressure fluctuations, stack effect, smoke buoyancy, and wind pressure. However, the pressure difference should not be so large that the door is difficult to open.

Airflow

Airflow has been used extensively to manage smoke from fires in subway, railroad, and highway tunnels (see [Chapter 13](#)). Large airflow rates are needed to control smoke flow, and these flow rates can supply additional oxygen to the fire. Because of the need for complex controls, airflow is not used as extensively in buildings. The control problem consists of having very small flows when a door is closed and then significantly increased flows when that door is open. Furthermore, it is a major concern that the airflow supplies oxygen to the fire. This section presents the basics of smoke control by airflow and demonstrates why this technique is rarely recommended.

Thomas (1970) determined that in a corridor in which there is a fire, airflow can almost totally prevent smoke from flowing upstream of the fire. Molecular diffusion is believed to transfer trace amounts of smoke, which are not hazardous but which are detectable as the smell of smoke upstream. Based on work by Thomas, the critical air velocity for most applications can be approximated as

$$V_k = 5.68\left(\frac{q_c}{W}\right)^{1/3} \tag{10}$$

where

- V_k = critical air velocity to prevent smoke backflow, fpm
- q_c = heat release rate into corridor, Btu/h
- W = corridor width, ft

This relation can be used when the fire is in the corridor or when smoke enters the corridor through an open doorway, air transfer grille, or other opening. Although critical velocities calculated from Equation (10) are general and approximate, they indicate the kind of air velocities required to prevent smoke backflow from fires of different sizes. For specific applications, other equations may be more appropriate: for tunnel applications, see [Chapter 13](#); for smoke management in atriums and other large spaces, see Klote and Milke (2002) and NFPA *Standard 92B*.

Although Equation (10) can be used to estimate the airflow rate necessary to prevent smoke backflow through an open door, the oxygen supplied is a concern. Huggett (1980) evaluated the oxygen consumed in the combustion of numerous natural and synthetic solids. He found that, for most materials involved in building fires, the energy released is approximately 5630 Btu per pound of oxygen. Air is 23.3% oxygen by mass. Thus, if all the oxygen in a pound of air is consumed, 1300 Btu is liberated. If all the oxygen in 1 cfm of air with a density of 0.075 lb_m/ft³ is consumed by fire, 5850 Btu/h is liberated.

Examples 2 and 3 demonstrate that the air needed to prevent smoke backflow can support an extremely large fire. Most commercial and residential buildings contain enough fuel (paper, cardboard, furniture, etc.) to support very large fires. Even when the amount of fuel is normally very small, short-term fuel loads (during building renovation, material delivery, etc.) can be significant. Therefore, using airflow for smoke control is not recommended, except when the fire is suppressed or in the rare cases when fuel can be restricted with confidence.

Example 2. What airflow at a doorway is needed to stop smoke backflow from a room fully involved in fire, and how large a fire can this airflow support?

A room fully involved in fire can have an energy release rate on the order of 8×10^6 Btu/h. Assume the door is 3 ft wide and 7 ft high. From Equation (10), $V_k = 5.68(8 \times 10^6/3)^{1/3} = 790$ fpm. A flow through the doorway of $790 \times 3 \times 7 = 16,600$ cfm is needed to prevent smoke from backflowing into the area.

If all the oxygen in this airflow is consumed in the fire, the heat liberated is $16,600 \text{ cfm} \times 5850 \text{ Btu/h} \cdot \text{cfm} = 9.7 \times 10^7$ Btu/h. This is over 10 times more than the heat generated by the fully involved room fire and indicates why airflow is generally not recommended for smoke control in buildings.

Example 3. What airflow is needed to stop smoke backflow from a wastebasket fire, and how large a fire can this airflow support?

A wastebasket fire can have an energy release rate on the order of 5×10^5 Btu/h. As in Example 2, $V_k = 5.68(5 \times 10^5/3)^{1/3} = 310$ fpm. A flow through the doorway of $310 \times 3 \times 7 = 6500$ cfm is needed to prevent smoke backflow.

If all the oxygen in this airflow is consumed in the fire, the heat liberated is $6500 \text{ cfm} \times 5850 \text{ Btu/h} \cdot \text{cfm} = 3.8 \times 10^7$ Btu/h. This is still many times greater than the fully involved room fire and further indicates why airflow is generally not recommended for smoke control in buildings.

Buoyancy

The buoyancy of hot combustion gases is used in both fan-powered and non-fan-powered venting systems. Fan-powered venting for large spaces is commonly used for atriums and covered shopping malls, and non-fan-powered venting is commonly used for large industrial and storage buildings. There is a concern that sprinkler flow will cool the smoke, reducing buoyancy and thus the system effectiveness. Research is needed in this area. Refer to Klote and Milke (2002) and NFPA *Standards* 92B and 204 for detailed design information about these systems.

SMOKE CONTROL SYSTEM DESIGN

Door-Opening Forces

The door-opening forces resulting from the pressure differences produced by a smoke control system must be considered. Unreasonably high door-opening forces can make it difficult or impossible for occupants to open doors to refuge areas or escape routes.

The force required to open a door is the sum of the forces to overcome the pressure difference across the door and to overcome the door closer. This can be expressed as

$$F = F_{dc} + \frac{5.20WA \Delta p}{2(W-d)} \quad (11)$$

where

F = total door-opening force, lb_f

F_{dc} = force to overcome door closer, lb_f

W = door width, ft

A = door area, ft^2

Δp = pressure difference across door, in. of water

d = distance from doorknob to edge of knob side of door, ft

This relation assumes that the door-opening force is applied at the knob. Door-opening force F_p caused by pressure difference can

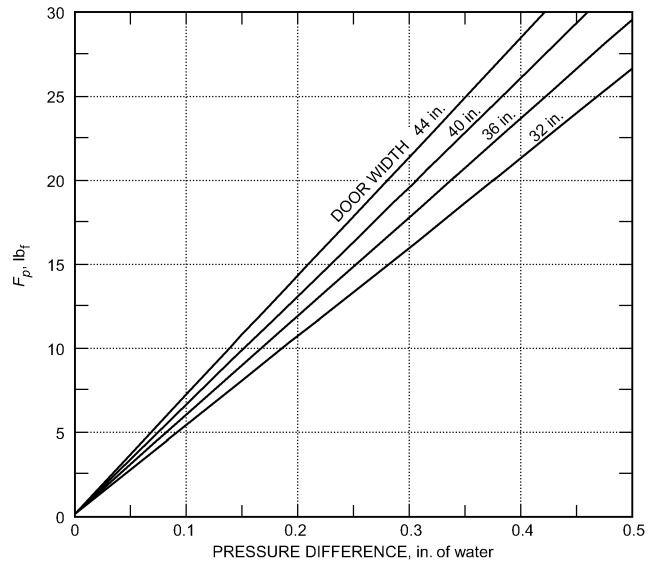

Fig. 7 Door-Opening Force Caused by Pressure Difference

be determined from Figure 7 for a value of $d = 3$ in. The force to overcome the door closer is usually greater than 3 lb_f and, in some cases, can be as great as 20 lb_f . For a door that is 7 ft high and 3 ft wide and subject to a pressure difference of 0.30 in. of water, the total door-opening force is 30 lb_f , if the force to overcome the door closer is 12 lb_f .

Flow Areas

In designing smoke control systems, airflow paths must be identified and evaluated. Some leakage paths are obvious, such as cracks around closed doors, open doors, elevator doors, windows, and air transfer grilles. Construction cracks in building walls are less obvious, but they are equally important.

The flow area of most large openings, such as open windows, can be calculated easily. However, flow areas of cracks are more difficult to evaluate. The area of these leakage paths depends on such features as workmanship, door fit, and weatherstripping. A 3 by 7 ft door with an average crack width of $1/8$ in. has a leakage area of 0.21 ft^2 . However, if this door is installed with a $3/4$ in. undercut, the leakage area is 0.36 ft^2 , a significant difference. The leakage area of elevator doors is in the range of 0.55 to 0.70 ft^2 per door.

For open stairwell doorways, Cresci (1973) found complex flow patterns; the resulting flow through open doorways was considerably below that calculated using the doorway's geometric area as the flow area in Equation (8). Based on this research, it is recommended that the design flow area of an open stairwell doorway be *half* the geometric area (door height \times width) of the doorway. An alternative for open stairwell doorways is to use the geometric area as the flow area and use a reduced flow coefficient. Because it does not allow the direct use of Equation (8), this approach is not used here.

Typical leakage areas for walls and floors of commercial buildings are tabulated as area ratios in Table 1. These data are based on a relatively small number of tests performed by the National Research Council of Canada (Shaw et al. 1993; Tamura and Shaw 1976a, 1976b, 1978; Tamura and Wilson 1966). Actual leakage areas depend primarily on workmanship rather than on construction materials, and in some cases, the flow areas in particular buildings may vary from the values listed. Data concerning air leakage through building components are also provided in Chapter 27 of the 2005 *ASHRAE Handbook—Fundamentals*.

Because a vent surface is usually covered by a louver and screen, a vent's flow area is less than its area (vent height \times width). Calculation

Table 1 Typical Leakage Areas for Walls and Floors of Commercial Buildings

Construction Element	Wall Tightness	Area Ratio
		A/A_w
Exterior building walls ^a (includes construction cracks and cracks around windows and doors)	Tight	0.50×10^{-4}
	Average	0.17×10^{-3}
	Loose	0.35×10^{-3}
	Very Loose	0.12×10^{-2}
Stairwell walls ^a (includes construction cracks but not cracks around windows or doors)	Tight	0.14×10^{-4}
	Average	0.11×10^{-3}
	Loose	0.35×10^{-3}
Elevator shaft walls ^a (includes construction cracks but not cracks around doors)	Tight	0.18×10^{-3}
	Average	0.84×10^{-3}
	Loose	0.18×10^{-2}
		A/A_f
Floors ^b (includes construction cracks and gaps around penetrations)	Tight	0.66×10^{-5}
	Average	0.52×10^{-4}
	Loose	0.17×10^{-3}

A = leakage area; A_w = wall area; A_f = floor area
 Leakage areas evaluated at ^a0.3 in. of water; ^b0.1 in. of water.

is further complicated because the louver slats are frequently slanted. Manufacturer's data should be used for specific information.

Effective Flow Areas

The concept of effective flow areas is useful for analyzing smoke control systems. The paths in the system can be in parallel with one another, in series, or a combination of parallel and series. The effective area of a system of flow areas is the area that gives the same flow as the system when it is subjected to the same pressure difference over the total system of flow paths. This is similar to the effective resistance of a system of electrical resistances. The effective flow area A_e for **parallel** leakage areas is the sum of the individual leakage paths:

$$A_e = \sum_{i=1}^n A_i \tag{12}$$

where n is the number of flow areas A_i in parallel.

For example, the effective area A_e for the three parallel leakage areas in [Figure 8](#) is

$$A_e = A_1 + A_2 + A_3 \tag{13}$$

If A_1 is 1.0 ft² and A_2 and A_3 are each 0.5 ft², then the effective flow area A_e is 2.0 ft².

The general rule for any number of leakage areas in **series** is

$$A_e = \left[\sum_{i=1}^n \frac{1}{A_i^2} \right]^{-0.5} \tag{14}$$

where n is the number of leakage areas A_i in series.

Three leakage areas in series from a pressurized space are illustrated in [Figure 9](#). The effective flow area of these paths is

$$A_e = \left(\frac{1}{A_1^2} + \frac{1}{A_2^2} + \frac{1}{A_3^2} \right)^{-0.5} \tag{15}$$

In smoke control analysis, there are frequently only two paths in series, and the effective leakage area is

$$A_e = \frac{A_1 A_2}{\sqrt{A_1^2 + A_2^2}} \tag{16}$$

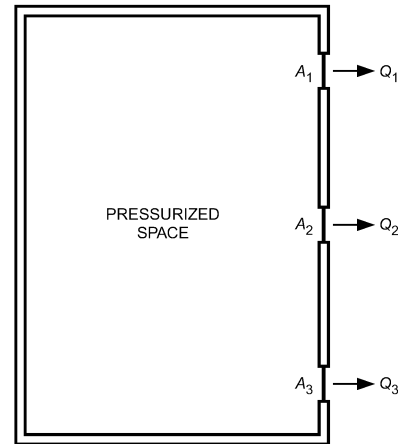

Fig. 8 Leakage Paths in Parallel

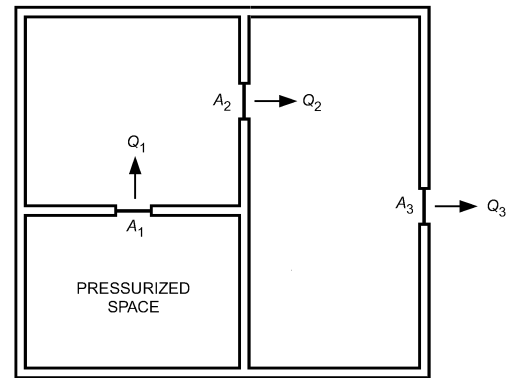

Fig. 9 Leakage Paths in Series

Example 4. Calculate the effective leakage area of two equal flow paths in series. Let $A = A_1 = A_2 = 0.20$ ft². From Equation (16),

$$A_e = \frac{A^2}{\sqrt{2A^2}} = 0.14 \text{ ft}^2$$

Example 5. Calculate the effective flow area of two flow paths in series, where $A_1 = 0.20$ ft² and $A_2 = 2.0$ ft². From Equation (16),

$$A_e = \frac{A_1 A_2}{\sqrt{A_1^2 + A_2^2}} = 0.199 \text{ ft}^2$$

Example 5 illustrates that when two paths are in series, and one is much larger than the other, the effective flow area is approximately equal to the smaller area.

Developing an effective area for a system of both parallel and series paths requires combining groups of parallel paths and series paths systematically. The system illustrated in [Figure 10](#) is analyzed as an example. The figure shows that A_2 and A_3 are in parallel; therefore, their effective area is

$$(A_{23})_e = A_2 + A_3$$

Areas A_4 , A_5 , and A_6 are also in parallel, so their effective area is

$$(A_{456})_e = A_4 + A_5 + A_6$$

These two effective areas are in series with A_1 . Therefore, the effective flow area of the system is given by

$$A_e = \left[\frac{1}{A_1^2} + \frac{1}{(A_{23})_e^2} + \frac{1}{(A_{456})_e^2} \right]^{-0.5}$$

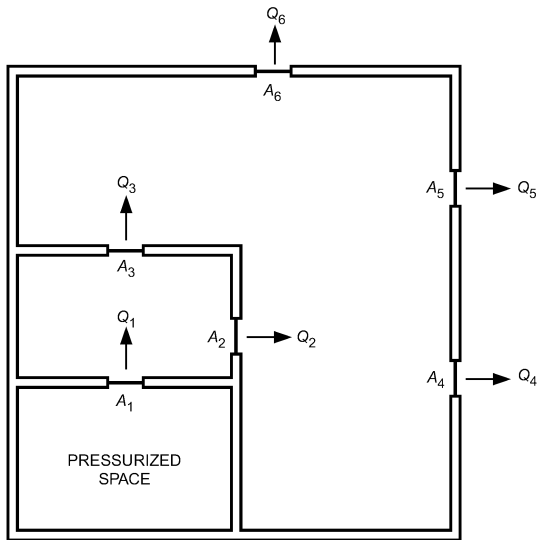

Fig. 10 Combination of Leakage Paths in Parallel and Series

Example 6. Calculate the effective area of the system in Figure 10, if the leakage areas are $A_1 = A_2 = A_3 = 0.2 \text{ ft}^2$ and $A_4 = A_5 = A_6 = 0.1 \text{ ft}^2$.

$$\begin{aligned}(A_{23})_e &= 0.4 \text{ ft}^2 \\ (A_{456})_e &= 0.3 \text{ ft}^2 \\ A_e &= 0.15 \text{ ft}^2\end{aligned}$$

Design Weather Data

Little weather information has been developed specifically for smoke control system design. Design temperatures for heating and cooling found in Chapter 28 of the 2005 *ASHRAE Handbook—Fundamentals* may be used. Extreme temperatures can be considerably lower than the winter design temperatures. For example, the 99% design temperature for Tallahassee, Florida, is 28°F, but the lowest temperature observed there was -2°F (NOAA 1979).

Temperatures are generally below the design values for short periods, and because of the thermal lag of building materials, these short intervals of low temperature usually do not cause problems with heating. However, there is no time lag for a smoke control system; it is therefore subjected to all the extreme forces of stack effect that exist the moment it operates. If the outside temperature is below the system's winter design temperature, stack effect problems may result. A similar situation can occur with summer design temperatures and reverse stack effect.

Extreme wind data for smoke management design are listed in Chapter 28 of the 2005 *ASHRAE Handbook—Fundamentals*.

Design Pressure Differences

Both the maximum and minimum allowable pressure differences across the boundaries of smoke control should be considered. The maximum allowable pressure difference should not cause excessive door-opening forces.

The minimum allowable pressure difference across a boundary of a smoke control system might be the difference such that no smoke leakage occurs during building evacuation. In this case, the smoke control system must produce sufficient pressure differences to overcome forces of wind, stack effect, or buoyancy of hot smoke. Pressure differences caused by wind and stack effect can be large in the event of a broken window in the fire compartment. Evaluation of these pressure differences depends on evacuation time, rate of fire growth, building configuration, and the presence of a fire suppression system. NFPA *Standard 92A* suggests values of minimum and maximum design pressure difference.

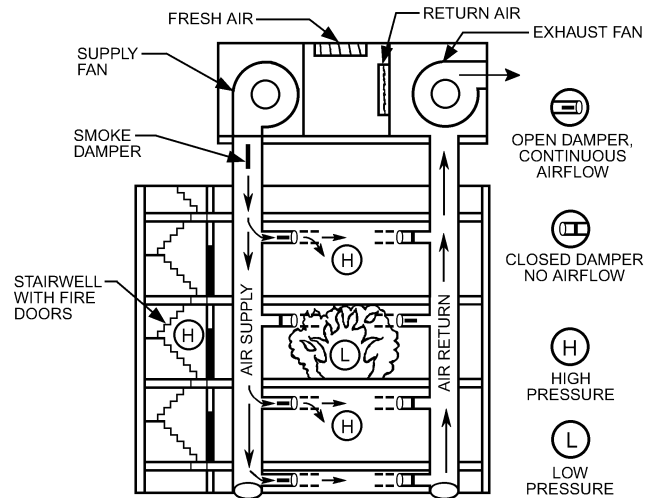

Note: If fans are off, all dampers should be closed.

Fig. 11 Smoke Control System Damper Recommendation

Open Doors

Another design concern is the number of doors that could be opened simultaneously when the smoke control system is operating. A design that allows all doors to be open simultaneously may ensure that the system always works, but often adds to system cost.

The number of doors that may be open simultaneously depends largely on building occupancy. For example, in a densely populated building, it is likely that all doors will be open during evacuation. However, if a staged evacuation plan or refuge area concept is incorporated in the building fire emergency plan, or if the building is sparsely occupied, only a few of the doors may be open during a fire.

FIRE AND SMOKE DAMPERS

Openings for ducts in walls and floors with fire resistance ratings should be protected by fire dampers and ceiling dampers, as required by local codes. Air transfer openings should also be protected. These dampers should be classified and labeled in accordance with Underwriters Laboratories (UL) *Standard 555*. Figure 11 shows recommended damper positions for smoke control.

A smoke damper can be used for either traditional smoke management (smoke containment) or smoke control. In **smoke management**, a smoke damper inhibits passage of smoke under the forces of buoyancy, stack effect, and wind. However, smoke dampers are only one of many elements (partitions, floors, doors) intended to inhibit smoke flow. In smoke management applications, the leakage characteristics of smoke dampers should be selected to be appropriate with the leakage of the other system elements.

In a **smoke control system**, a smoke damper inhibits the passage of air that may or may not contain smoke. A damper does not need low leakage characteristics when outside (fresh) air is on the high-pressure side of the damper, as is the case for dampers that shut off supply air from a smoke zone or that shut off exhaust air from a non-smoke zone. In these cases, moderate leakage of smoke-free air through the damper does not adversely affect control of smoke movement. It is best to design smoke control systems so that only smoke-free air is on the high-pressure side of a closed smoke damper.

Smoke dampers should be classified and listed in accordance with UL *Standard 555S* for temperature, leakage, and operating velocity. The velocity rating of a smoke damper is the velocity at which the actuator will open and close the damper.

At locations requiring both smoke and fire dampers, combination dampers meeting the requirements of both UL *Standards 555*

and 555S can be used. The combination fire/smoke dampers must close when they reach their UL *Standard* 555S temperature rating to maintain the integrity of the firewall.

Fire, ceiling, and smoke dampers should be installed in accordance with the manufacturers' instructions. NFPA *Standard* 90A gives general guidelines on locations requiring these dampers.

The supply and return/smoke dampers should be a minimum of Class II leakage at 250°F. The return air damper should be a minimum of Class I leakage at 250°F to prevent recirculation of smoke exhaust. The operating velocity of the dampers should be evaluated when the dampers are in smoke control mode. To minimize velocity build-up, only zones adjacent to the fire need to be pressurized.

The exhaust ductwork and fan must be designed to handle the temperature of the exhaust smoke. This temperature can be lowered by making the smoke control zones large or by pressurizing only the zones adjacent to the fire zone and leaving all the other zones operating normally.

Fans Used to Exhaust Smoke

Understanding building code requirements for high-temperature fans in smoke control systems is important for both designers, who must select fans that can operate satisfactorily at elevated temperatures, and manufacturers, who can then design suitable off-the-shelf fans rather than customizing fans for each application. Only fans designed for use under elevated temperatures should be used in smoke management applications; other types may fail, or their performance may change because of component deformation or altered clearances among components. Also, some smoke exhaust applications (e.g., transit tunnels) require that smoke-handling fans reverse direction repeatedly on demand. Until recently, standards did not address reversibility or airflow performances of high-temperature fans at ambient and elevated temperatures. To allow manufacturers to provide suitable off-the-shelf products, a standard method of test (MOT) and ratings scale have been developed.

ANSI/ASHRAE *Standard* 149 provides testing laboratories with standard testing methods for fan characteristics specific to smoke exhaust functions, including (1) aerodynamic performance, (2) operation at specified elevated temperature, (3) reversal, and (4) damper performance (for dampers included with the fan).

AMCA *Publication* 212 establishes ratings to allow consistent comparison among catalog test data. Model code requirements for elevated temperature and duration of operation are charted on a graph, which is divided into several fan performance groups. Manufacturers can request that laboratories test fans according to ANSI/ASHRAE *Standard* 149; those data can then be incorporated into catalogs for off-the-shelf products according to AMCA *Publication* 212 ratings, allowing designers to select the most appropriate models and performances for their specific applications. This allows designers and code officials to compare different manufacturers' products more easily, and enhances confidence that products will perform as intended; it also allows manufacturers to provide more cost-efficient off-the-shelf products rather than custom-designing fans for each application.

PRESSURIZED STAIRWELLS

Many pressurized stairwells have been designed and built to provide a smoke-free escape route in the event of a building fire. They also provide a smoke-free staging area for firefighters. On the fire floor, a pressurized stairwell must maintain a positive pressure difference across a closed stairwell door to prevent smoke infiltration.

During building fires, some stairwell doors are opened intermittently during evacuation and fire fighting, and some doors may even be blocked open. Ideally, when the stairwell door is opened on the fire floor, airflow through the door should be sufficient to prevent smoke backflow. Designing a system to achieve this goal is difficult because of the many combinations of open stairwell doors and weather conditions affecting airflow.

Stairwell pressurization systems may be single- or multiple-injection systems. A **single-injection system** supplies pressurized air to the stairwell at one location, usually at the top. Associated with this system is the potential for smoke to enter the stairwell through the pressurization fan intake. Therefore, automatic shut-down during such an event should be considered.

For tall stairwells, single-injection systems can fail when a few doors are open near the air supply injection point, especially in bottom-injection systems when a ground-level stairwell door is open.

For tall stairwells, supply air can be supplied at a number of locations over the height of the stairwell. [Figures 12](#) and [13](#) show two examples of **multiple-injection systems** that can be used to overcome the limitations of single-injection systems. In these figures, the supply duct is shown in a separate shaft. However, systems have been built that eliminated the expense of a separate duct shaft by locating the supply duct in the stairwell itself. In such a case, care must be taken that the duct does not obstruct orderly building evacuation.

Stairwell Compartmentation

Compartmentation of the stairwell into a number of sections is one alternative to multiple injection ([Figure 14](#)). When the doors between compartments are open, the effect of compartmentation is

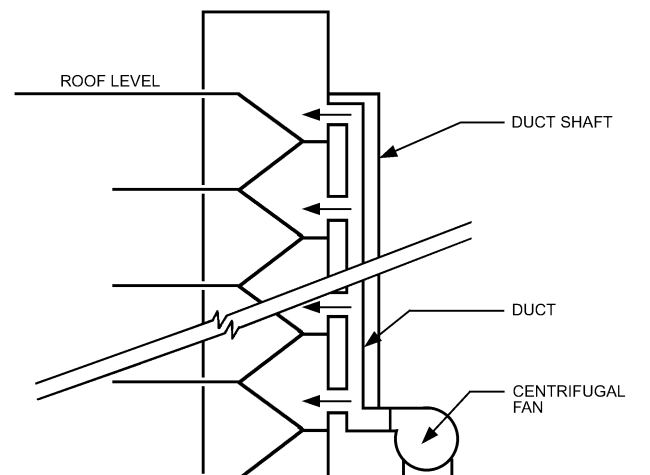

Fig. 12 Stairwell Pressurization by Multiple Injection with Fan Located at Ground Level

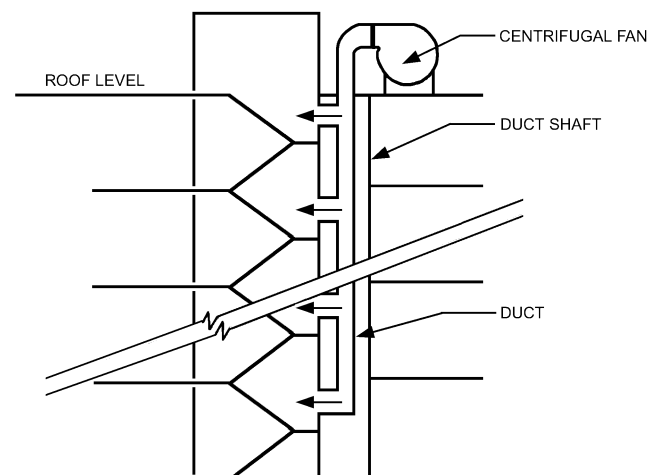
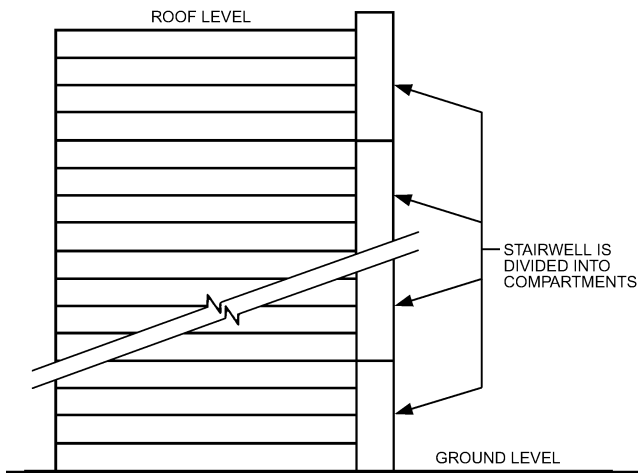

Fig. 13 Stairwell Pressurization by Multiple Injection with Roof-Mounted Fan



Note: Each four-floor compartment has a least one supply air injection point.

Fig. 14 Compartmentation of Pressurized Stairwell

lost. For this reason, compartmentation is inappropriate for densely populated buildings where total building evacuation by the stairwell is planned in the event of fire. However, when a staged evacuation plan is used and the system is designed to operate successfully with the maximum number of doors between compartments open, compartmentation can effectively pressurize tall stairwells.

Stairwell Analysis

This section presents an analysis for a pressurized stairwell in a building without vertical leakage. This method closely approximates the performance of pressurized stairwells in buildings without elevators. It is also useful for buildings with vertical leakage because it yields conservative results. For evaluating vertical leakage through the building or with open stairwell doors, computer analysis is recommended. The analysis is for buildings where the leakage areas are the same for each floor of the building and where the only significant driving forces are the stairwell pressurization system and the indoor-outdoor temperature difference.

The pressure difference Δp_{sb} between the stairwell and the building can be expressed as

$$\Delta p_{sb} = \Delta p_{sbb} + \frac{By}{1 + (A_{sb}/A_{bo})^2} \quad (17)$$

where

Δp_{sbb} = pressure difference between stairwell and building at stairwell bottom, in. of water

$B = 7.64(1/T_o - 1/T_s)$ at sea level standard pressure

y = distance above stairwell bottom, ft

A_{sb} = flow area between stairwell and building (per floor), ft²

A_{bo} = flow area between building and outside (per floor), ft²

T_o = temperature of outside air, °R

T_s = temperature of stairwell air, °R

For a stairwell with no leakage directly to the outside, the flow rate of pressurization air is

$$Q = 1740NA_{sb} \left(\frac{\Delta p_{sbt}^{3/2} - \Delta p_{sbb}^{3/2}}{\Delta p_{sbt} - \Delta p_{sbb}} \right) \quad (18)$$

where

Q = volumetric flow rate, cfm

N = number of floors

Δp_{sbt} = pressure difference from stairwell to building at stairwell top, in. of water

Example 7. Each story of a 15-story stairwell is 10.8 ft high. The stairwell has a single-leaf door at each floor leading to the occupant space and one ground-level door to the outside. The exterior of the building has a wall area of 6030 ft² per floor. The exterior building walls and stairwell walls are of average leakiness. The stairwell wall area is 560 ft² per floor. The area of the gap around each stairwell door to the building is 0.26 ft². The exterior door is well gasketed, and its leakage can be neglected when it is closed.

Outside design temperature $T_o = 474^\circ\text{R}$; stairwell temperature $T_s = 530^\circ\text{R}$; maximum design pressure differences when all stairwell doors are closed is 0.35 in. of water; the minimum allowable pressure difference is 0.052 in. of water.

Using the leakage ratio for an exterior building wall of average tightness from Table 1, $A_{bo} = 6030(0.21 \times 10^{-3}) = 1.27$ ft². Using the leakage ratio for a stairwell wall of average tightness from Table 1, the leakage area of the stairwell wall is $560(0.11 \times 10^{-3}) = 0.06$ ft². The value of A_{sb} equals the leakage area of the stairwell wall plus the gaps around the closed doors: $A_{sb} = 0.06 + 0.26 = 0.32$ ft². The temperature factor B is calculated at 0.00170 in. of water/ft. The pressure difference at the stairwell bottom is selected as $\Delta p_{sbb} = 0.080$ in. of water to provide an extra degree of protection above the minimum allowable value of 0.052 in. of water. The pressure difference Δp_{sbt} is calculated from Equation (17) at 0.339 in. of water, using $y = 15(10.8) = 162$ ft. Thus, Δp_{sbt} does not exceed the maximum allowable pressure. The flow rate of pressurization air is calculated from Equation (18) at 5640 cfm.

The flow rate depends strongly on the leakage area around the closed doors and on the leakage area in the stairwell walls. In practice, these areas are difficult to evaluate and even more difficult to control. If flow area A_{sb} in Example 7 were 0.54 ft² rather than 0.32 ft², Equation (18) would give a flow rate of pressurization air of 9500 cfm. A fan with a sheave allows adjustment of supply air to offset for variations in actual leakage from the values used in design calculations.

Stairwell Pressurization and Open Doors

The simple pressurization system discussed in the previous section has two limitations regarding open doors. First, when a stairwell door to the outside and building doors are open, the simple system cannot provide enough airflow through building doorways to prevent smoke backflow. Second, when stairwell doors are open, pressure difference across the closed doors can drop to low levels. Two systems used to overcome these problems are overpressure relief (Tamura 1990) and supply fan bypass.

Overpressure Relief. The total airflow rate is selected to provide the minimum air velocity when a specific number of doors are open. When all the doors are closed, part of this air is relieved through a vent to prevent excessive pressure build-up, which could cause excessive door-opening forces. This excess air should be vented from the stairwell to the street-level floor. Fire and relief dampers should be the low-leakage type. Stairwell doors should have gasket seals at sides and top, leaving the bottom gap open for relief

Barometric dampers that close when pressure drops below a specified value can minimize air loss through the vent when doors are open. Figure 15 illustrates a pressurized stairwell with overpressure relief vents to the building at each floor. In systems with vents between stairwell and building, the vents typically have a fire damper in series with the barometric damper. To conserve energy, these fire dampers are normally closed, but they open when the pressurization system is activated. This arrangement also reduces the possibility of the annoying damper chatter that frequently occurs with barometric dampers.

An exhaust duct can provide overpressure relief in a pressurized stairwell. The system is designed so that the normal resistance of a nonpowered exhaust duct maintains pressure differences within the design limits.

Exhaust fans can also relieve excess pressure when all stairwell doors are closed. An exhaust fan should be controlled by a differential pressure sensor, so that it will not operate when the pressure difference between stairwell and building falls below a specified level.

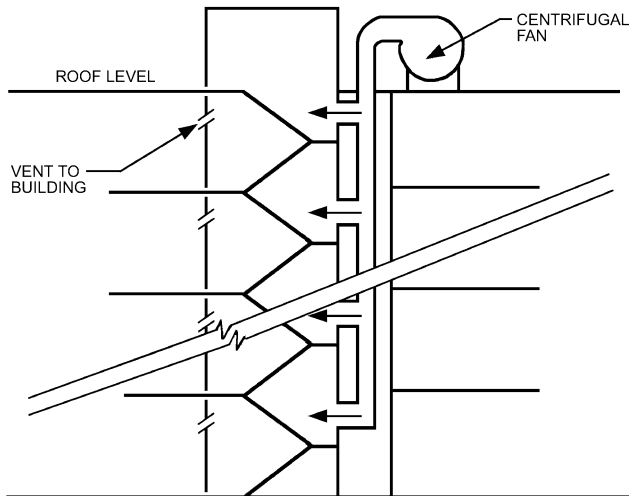

Notes: 1. Vents to building have barometric damper and fire damper in series.
 2. Roof-mounted supply fan is shown; however, fan may be located at any level.
 3. Manually operated damper may be located at stairwell top for smoke purging by fire department.

Fig. 15 Stairwell Pressurization with Vents to Building at Each Floor

This control should prevent the fan from pulling smoke into the stairwell when a number of open doors have reduced stairwell pressurization. The exhaust fan should be specifically sized so that the pressurization system performs within design limits. A wind shield is recommended because an exhaust fan can be adversely affected by the wind.

An alternative method of venting a stairwell is through an automatically opening stairwell door to the outside at ground level. Under normal conditions, this door would be closed and, in most cases, locked for security reasons. Provisions are needed to prevent this lock from conflicting with the automatic operation of the system. Possible adverse wind effects are also a concern with a system that uses an open outside door as a vent. Occasionally, high local wind velocities develop near the exterior stairwell door; such winds are difficult to estimate without expensive modeling. Nearby obstructions can act as windbreaks or wind shields.

Supply Fan Bypass. In this system, the supply fan is sized to provide at least the minimum air velocity when the design number of doors are open. Figure 16 illustrates such a system. The flow rate of air into the stairwell is varied by modulating bypass dampers, which are controlled by one or more static pressure sensors that sense the pressure difference between the stairwell and the building. When all the stairwell doors are closed, the pressure difference increases and the bypass damper opens to increase the bypass air and decrease the flow of supply air to the stairwell. In this manner, excessive stairwell pressures and excessive pressure differences between the stairwell and the building are prevented.

ELEVATORS

Elevator smoke control systems intended for use by firefighters should keep elevator cars, elevator shafts, and elevator machinery rooms smoke-free. Small amounts of smoke in these spaces are acceptable, provided that the smoke is nontoxic and that operation of elevator equipment is not affected. Elevator smoke control systems intended for fire evacuation of people unable to self-rescue or other building occupants should also keep elevator lobbies smoke-free or nearly smoke-free. Obstacles to fire evacuation by elevators include

- Logistics of evacuation
- Reliability of electrical power

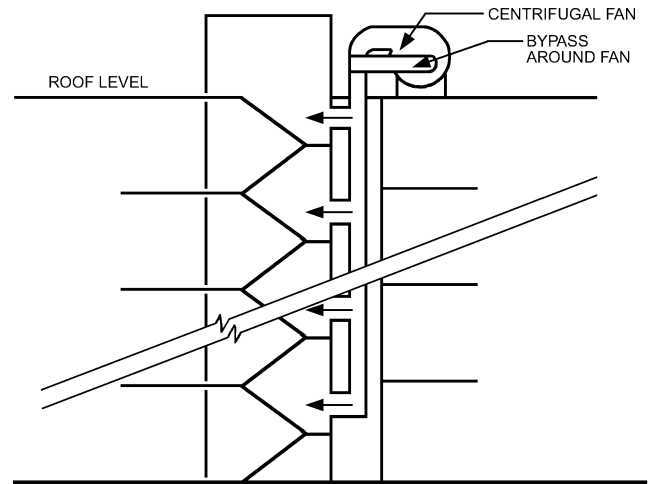

Notes: 1. Fan bypass controlled by one or more static-pressure sensors located between stairwell and building.
 2. Roof-mounted supply fan is shown; however, fan may be located at any level.
 3. Manually operated damper may be located at stairwell top for smoke purging by fire department.

Fig. 16 Stairwell Pressurization with Bypass Around Supply Fan

- Jamming of elevator doors
- Fire and smoke protection

All these obstacles, except smoke protection, can be addressed by existing technology (Klote 1984).

Klote and Tamura (1986) studied conceptual elevator smoke control systems for evacuation of people unable to self-rescue. The major problem was maintaining pressurization with open building doors, especially doors on the ground floor. Of the systems evaluated, only one with a supply fan bypass with feedback control maintained adequate pressurization with any combination of open or closed doors. There are probably other systems capable of providing adequate smoke control; the procedure used by Klote and Tamura can be viewed as an example of a method of evaluating the performance of a system to determine whether it suits the particular characteristics of a building under construction.

Transient pressures caused by **piston effect** when an elevator car moves in a shaft have been a concern in elevator smoke control. Piston effect is not a concern for slow-moving cars in multiple-car shafts, but can be considerable for fast cars in single-car shafts.

ZONE SMOKE CONTROL

Klote (1990) conducted a series of tests on full-scale fires that demonstrated that zone smoke control can restrict smoke movement to the zone where a fire starts.

Pressurized stairwells are intended to prevent smoke infiltration into stairwells. However, in a building with only stairwell pressurization, smoke can flow through cracks in floors and partitions and through shafts to damage property and threaten life at locations remote from the fire. Zone smoke control is intended to limit this smoke movement.

A building is divided into a number of smoke control zones, each separated from the others by partitions, floors, and doors that can be closed to inhibit smoke movement. In the event of a fire, pressure differences and airflows produced by mechanical fans limit spread of smoke from the zone in which the fire started. The concentration of smoke in this zone goes unchecked; thus, in zone smoke control systems, occupants should evacuate the smoke zone as soon as possible after fire detection.

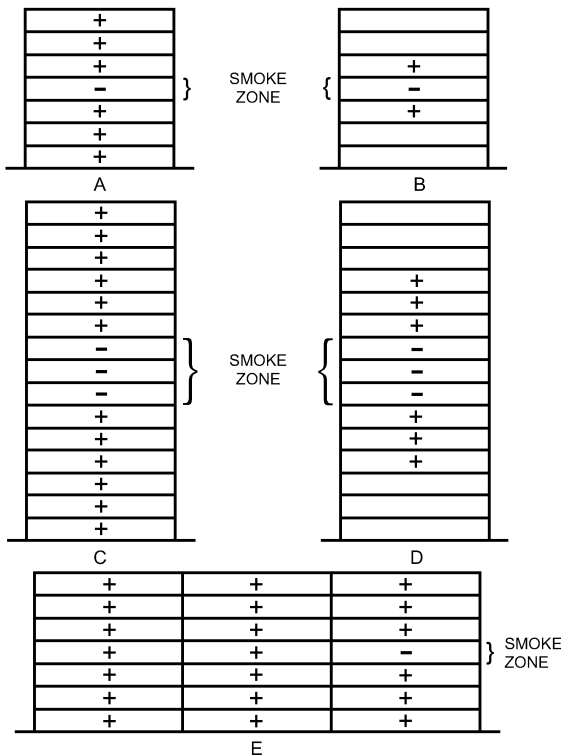

Note:
In the above figures, the smoke zone is indicated by a minus sign, and pressurized spaces are indicated by a plus sign. Each floor can be a smoke control zone as in A and B, or a smoke zone can consist of more than one floor as in C and D. All nonsmoke zones adjacent to the smoke zone may be pressurized, as in A and C, or only nonsmoke zones adjacent to the smoke zone may be pressurized, as in B and D. A smoke zone can also be limited to a part of a floor as in E.

Fig. 17 Some Arrangements of Smoke Control Zones

A smoke control zone can consist of one floor, more than one floor, or part of a floor. Sprinkler zones and smoke control zones should be coordinated so that sprinkler water flow activates the zone's smoke control system. Some arrangements of smoke control zones are illustrated in Figure 17. All the nonsmoke zones in the building may be pressurized. The term **pressure sandwich** describes cases where only zones adjacent to the smoke zone are pressurized, as in Figures 17B and 17D.

Zone smoke control is intended to limit smoke movement to the smoke zone by the use of pressurization. Pressure differences in the desired direction across the barriers of a smoke zone can be achieved by supplying outside (fresh) air to nonsmoke zones, by venting the smoke zone, or by a combination of these methods.

Venting smoke from a smoke zone prevents significant overpressure from thermal expansion of gases caused by the fire. This venting can be accomplished by exterior wall vents, smoke shafts, and mechanical venting (exhausting). However, venting only slightly reduces smoke concentration in the smoke zone.

COMPUTER ANALYSIS FOR PRESSURIZATION SYSTEMS

Because of the complex airflow in buildings, network computer programs were developed to model the airflow with pressurization systems. These models represent rooms and shafts by nodes; airflow is from nodes of high pressure to nodes of lower pressure. Some programs calculate steady-state airflow and pressures throughout a building (Sander 1974; Sander and Tamura 1973). Other programs go beyond this to calculate the smoke concentrations that would be produced throughout a building in

the event of a fire (Evers and Waterhouse 1978; Rilling 1978; Wakamatsu 1977; Yoshida et al. 1979).

The ASCOS program was developed specifically for analyzing pressurization smoke control systems (Klote 1982). ASCOS was the most widely used program for smoke control analysis (Said 1988), and has been validated against field data from flow experiments at an eight-story tower in Champs sur Marne, France (Klote and Bodart 1985). ASCOS and the other network models have been used extensively for design and for parametric analysis of the performance of smoke control systems. However, ASCOS was intended as a research tool for application to 10- and 20-story buildings. Not surprisingly, convergence failures have been encountered with applications to much larger buildings.

Wray and Yuill (1993) evaluated several flow algorithms to find the most appropriate one for analysis of smoke control systems. They selected the AIRNET flow routine developed by Walton (1989) as the best algorithm based on computational speed and use of computer memory. None of the algorithms from this study takes advantage of the repetitive nature of building flow networks, so data entry is difficult. However, Walton and Dols (2005) developed CONTAM, a public domain program with an improved version of the AIRNET flow routine and an easier method of input. CONTAM can be downloaded free of charge from http://www.bfrl.nist.gov/IAQ_analysis/CONTAM.

These models are appropriate for analyzing systems that use pressurization to control smoke flow. For systems that rely on buoyancy of hot smoke (such as atrium smoke exhaust), **zone fire models** are appropriate. The concepts behind zone fire modeling are discussed by Bukowski (1991), Jones (1983), and Mitler (1985). Some frequently used zone models are ASET (Cooper 1985), CCFM (Cooper and Forney 1987), and CFAST (Peacock et al. 1993). Milke and Mowrer (1994) enhanced the CCFM model for atrium applications.

SMOKE MANAGEMENT IN LARGE SPACES

In recent years, atrium buildings have become commonplace. Other large, open spaces include enclosed shopping malls, arcades, sports arenas, exhibition halls, and airplane hangars. For simplicity, the term **atrium** is used in this chapter in a generic sense to mean any of these large spaces. Traditional fire protection by compartmentation is not applicable to these large-volume spaces.

Most atrium smoke management systems are designed to prevent exposure of occupants to smoke during evacuation; this is the approach described in this section. An alternative goal is to maintain tenable conditions even when occupants have some contact with smoke, as discussed in the section on Tenability Systems.

The following approaches can be used to manage smoke in atriums:

- **Smoke filling.** This approach allows smoke to fill the atrium space while occupants evacuate the atrium. It applies only to spaces where the smoke-filling time is sufficient for both decision making and evacuation. Nelson and Mowrer (2002), Chapter 4 of Klote and Milke (2002), and Proulx (2002) have information on people movement during evacuation. The filling time can be estimated either by zone fire models or by filling equations [e.g., Equation (21)].
- **Unsteady clear height with upper layer exhaust.** This approach exhausts smoke from the top of the atrium at a rate such that occupants have sufficient time for decision making and evacuation. It requires analysis of people movement and fire model analysis of smoke filling.
- **Steady clear height with upper layer exhaust.** This approach exhausts smoke from the top of the atrium to achieve a steady clear height for a steady fire (Figure 18). A calculation method is presented in the section on Steady Clear Height with Upper Layer Exhaust.

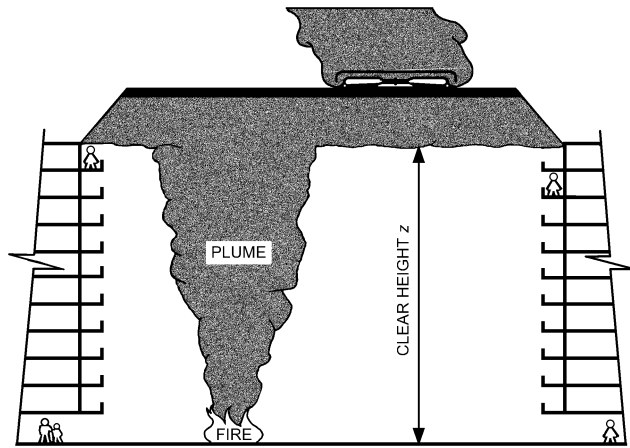

Fig. 18 Smoke Exhaust to Maintain Steady Clear Height

Design Fires

The design fire has a major effect on the atrium smoke management system. Fire size is expressed in terms of rate of heat release. Fire growth is the rate of change of the heat release rate and is sometimes expressed as a growth constant that identifies the time required for the fire to attain a particular rate of heat release. Designs may be based on either steady fires or unsteady fires.

Fires are by nature unsteady, but the steady fire is a very useful idealization. **Steady fires** have a constant heat release rate. In many applications, using a steady design fire leads to straightforward and conservative design.

Morgan (1979) suggests 44 Btu/s·ft² as a typical rate of heat release per unit floor area for mercantile occupancies. Fang and Breese (1980) found about the same rate of heat release for residential occupancies. Law (1982) and Morgan and Hansell (1987) suggest a heat release rate per unit floor area for office buildings of 20 Btu/s·ft².

In many atriums, fuel loading is severely restricted with the intent of restricting fire size. Such atriums are characterized by interior finishes of metal, brick, stone, or gypsum board and furnished with objects made of similar materials plus plants. Even in such a **fuel-restricted atrium**, many combustible objects are present for short periods. Packing materials, holiday decorations, displays, construction materials, and furniture being moved into another part of the building are a few examples of **transient fuels**.

In this chapter, a heat release rate per floor area of 20 Btu/s·ft² is used for a fuel-restricted atrium, and 44 Btu/s·ft² is used for atriums containing furniture, wood, or other combustible materials.

Transient fuels must not be overlooked when selecting a design fire. Klote and Milke (2002) suggest incorporating transient fuels in a design fire by considering the fire occurring over 100 ft² of floor space. This results in a design fire of 2000 Btu/s for fuel-restricted atriums. In an atrium with combustibles, the design fire would be 4400 Btu/s. However, the area involved in fire may be much greater; flame spread considerations must be taken into account (Klote and Milke 2002; NFPA Standard 92B). A large atrium fire of 25,000 Btu/s would involve an area of 568 ft² at 44 Btu/s·ft². Table 2 lists some steady design fires.

Unsteady fires are often characterized by the following equation:

$$q = 1000 \left(\frac{t}{t_g} \right)^2 \tag{19}$$

where

- q = heat release rate of fire, Btu/s
- t = time, s
- t_g = growth time, s

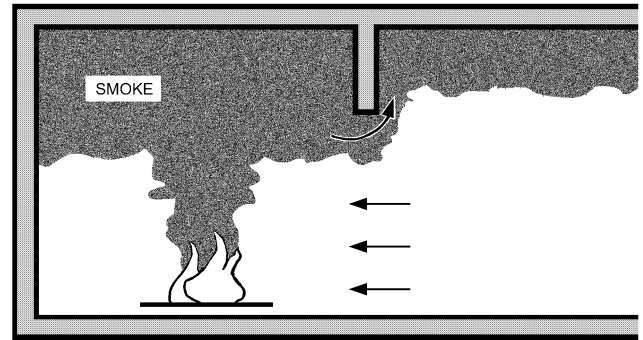

A. SKETCH OF ROOM FIRE

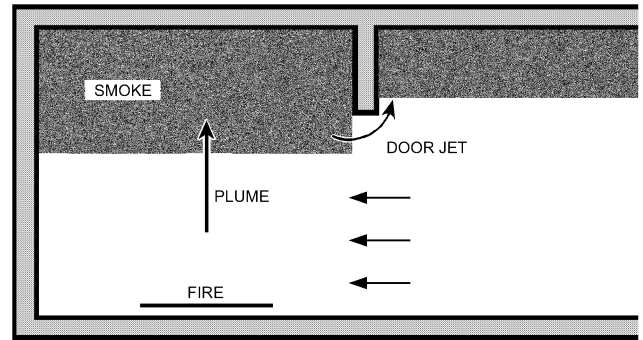

B. ZONE MODEL IDEALIZATION OF ROOM FIRE

Fig. 19 Room Fire and Zone Fire Model Idealization

These unsteady fires are called *t*-squared fires; typical growth times are listed in Table 3.

Zone Fire Models

Table 2 Steady Design Fire Sizes for Atriums

	Btu/s
Minimum fire for fuel-restricted atrium	2,000
Minimum fire for atrium with combustibles	5,000
Large fires	25,000

Table 3 Typical Fire Growth Times

t-Squared Fires	Growth Time t _g , s
Slow ^a	600
Medium ^a	300
Fast ^a	150
Ultrafast ^b	75

^aConstants based on data from NFPA Standards 92B and 204.

^bConstant based on data from Nelson (1987).

Atrium smoke management design is based on the zone fire model concept. This concept has been applied to several computer models used for atrium smoke management design analysis, including the Harvard Code (Mitler and Emmons 1981), ASET (Cooper 1985), the BRI Model (Tanaka 1983), CCFM (Cooper and Forney 1987), and CFAST (Peacock et al. 1993). The University of Maryland modified CCFM specifically for atrium smoke management design (Milke and Mowrer 1994). Although each of these models has unique features, they all share the same basic two-zone model concept.

For more information about zone models, see Mitler (1984), Mitler and Rockett (1986), and Quintiere (1989). The ASET-B model (Walton 1985) is a good starting point for learning about zone models.

Zone models were developed for room fires. In a room fire, hot gases rise above the fire, forming a **plume**. As the plume rises, it entrains air from the room so that the diameter and mass flow rate of the plume increase with elevation. Accordingly, plume temperature decreases with elevation. Fire gases from the plume flow up to the ceiling and form a hot stratified layer under the ceiling. Hot gases can flow through openings in walls to other spaces; this flow is referred to as a **door jet**, which is similar to a plume, except that it flows through an opening in a wall.

Figure 19A is a sketch of a room fire. Zone modeling is an idealization of the room fire conditions, as illustrated in Figure 19B. For this idealization, the temperatures of the hot upper and lower layers of the room are uniform. The height of the discontinuity between these layers is the same everywhere. The dynamic effects on pressure are considered negligible, so pressures are treated as hydrostatic. Other properties are considered uniform for each layer. Algebraic equations are used to calculate the mass flows caused by plumes and door jets.

Many computer zone models allow exhaust from the upper layer, which is essential for simulating atrium smoke exhaust systems. Heat transfer is estimated by methods ranging from a simple allowance as a fraction of the heat released by the fire to a complicated simulation including the effects of conduction, convection, and radiation.

Atrium Smoke Filling by a Steady Fire

The following experimental correlation of the accumulation of smoke in a space by a steady fire is the **steady-filling equation**:

$$\frac{z}{H} = 0.67 - 0.28 \ln \left(\frac{tq^{1/3} H^{-4/3}}{A/H^2} \right) \quad (20)$$

where

- z = height of first indication of smoke above fire, ft
- H = ceiling height above fire, ft
- t = time, s
- q = heat release rate from steady fire, Btu/s
- A = cross-sectional area of atrium, ft²

Equation (20) is conservative in that it estimates the height of the first indication of smoke above the fire rather than the smoke interface, as illustrated in Figure 20. In the idealized zone model, the smoke interface is considered to be a height where there is smoke above and none below. In actual fires, there is a gradual transition zone between the lower cool layer and upper hot layer. The first indication of smoke can be thought of as the bottom of the transition zone. Another factor making Equation (20) conservative is that it is based on a plume that has no contact with the walls, which would reduce entrainment of air.

Equation (20) is for a constant cross-sectional area with respect to height. For other atrium shapes, physical modeling or computational fluid dynamics (see Chapter 34 of the 2005 ASHRAE Handbook—Fundamentals for more information) can be used. Alternatively, a sensitivity analysis can be made using Equation (20) to set bounds on the filling time for an atrium of complex shape. The equation is appropriate for A/H^2 from 0.9 to 14 and for values of z greater than or equal to 20% of H . A value of z/H greater than 1 means that the smoke layer under the ceiling has not yet begun to descend. These conditions can be expressed as

$$A = \text{Constant with respect to } H$$

$$0.2 \leq \frac{z}{H} < 1.0$$

$$0.9 \leq \frac{A}{H^2} \leq 14$$

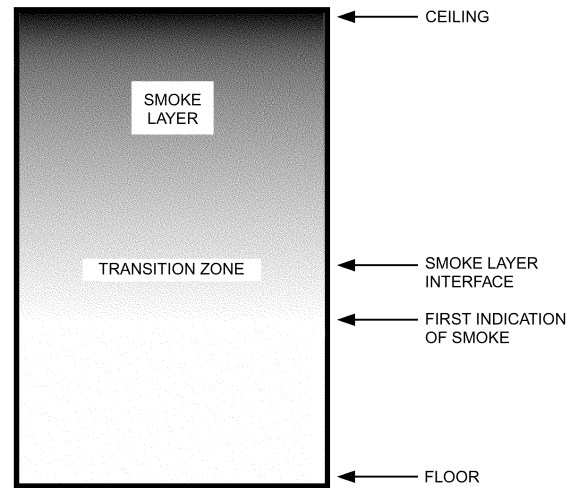

Fig. 20 Smoke Layer Interface

When Equation (20) is solved for z/H , z/H is often outside the acceptable range. Equation (20) can be solved for time.

$$t = \frac{A}{H^2} \times \frac{H^{4/3}}{q^{1/3}} \exp \left[\frac{1}{0.28} \left(0.67 - \frac{z}{H} \right) \right] \quad (21)$$

Atrium Smoke Filling by an Unsteady Fire

To analyze atrium smoke filling with an unsteady fire, use zone fire or CFD models. Klotz and Milke (2002) provide an algebraic equation for the smoke-filling time for an atrium with a t -squared fire, but this equation has limited applicability because t -squared fires can be extremely large for the times considered in many smoke-filling applications.

Steady Clear Height with Upper Layer Exhaust

Figure 18 illustrates smoke exhaust from the hot smoke layer at the top of an atrium to maintain a steady clear height. Smoke flow into the upper layer from the fire plume depends on the fire's heat release rate, clear height, fuel type, and fuel orientation. The following is a generalized plume approximation that does not take into account the specifics of the material being burned.

$$\dot{m} = 0.022q_c^{1/3} z^{5/3} + 0.0042q_c \quad (22)$$

where

- \dot{m} = mass flow of plume, lb_m/s
- q_c = convective heat release rate of fire, Btu/s
- z = clear height above top of fuel, ft

Clear height z is the distance from the top of the fuel to the interface between the "clear" space and the smoke layer. Because a smoke management system generally must protect against fire at any location, it is suggested that the top of the fuel be considered at the floor level.

Equation (22) is not applicable when the mean flame height is greater than the clear height. An approximate relationship for mean flame height is

$$z_f = 0.533q_c^{2/5} \quad (23)$$

where z_f = mean flame height, ft.

The convective portion q_c of the heat release rate can be expressed as

$$q_c = \xi q \quad (24)$$

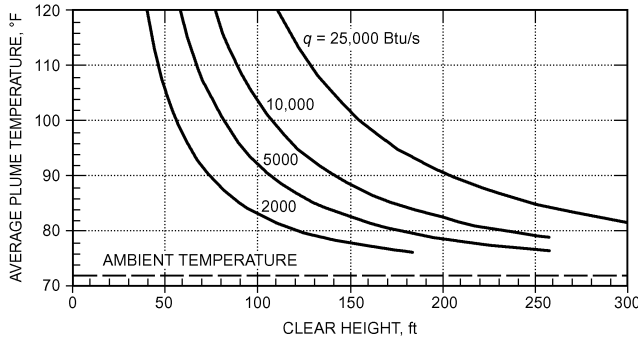

Note: Plume equations should not be used when plume temperature is less than 4°F above ambient.

Fig. 21 Average Plume Temperature

where ξ is the convective fraction of heat release. The convective fraction depends on the material being burned, heat conduction through the fuel, and the radiative heat transfer of the flames, but a value of 0.7 is often used.

The temperature of smoke entering the upper smoke layer is

$$T_p = T_a + \frac{q_c}{\dot{m}c_p} \quad (25)$$

where

- T_p = plume temperature at clear height, °R
- T_a = ambient temperature, °R
- \dot{m} = mass flow of plume, lb_m/s
- q_c = convective heat release rate of fire, Btu/s
- c_p = specific heat of plume gases, Btu/lb·°F

Figure 21 shows plume temperature as a function of height above the fuel as calculated from Equations (22) and (25). Smoke plumes consist primarily of air mixed with combustion products, and the specific heat of plume gases is generally taken to be the same as that of air ($c_p = 0.24$ Btu/lb·°F). Equation (22) was developed for strongly buoyant plumes. For small temperature differences between the plume and ambient, errors because of low buoyancy could be significant. This topic needs study, and, in the absence of better data, it is recommended that the plume equations not be used when this temperature difference is small (less than 4°F).

The density of smoke gases can be calculated from the perfect gas law:

$$\rho = \frac{p}{RT} \quad (26)$$

where

- ρ = density, lb_m/ft³
- p = absolute pressure, lb_f/ft²
- R = gas constant, ft·lb_f/lb_m·°R
- T = absolute temperature of smoke gases, °R

Volumetric flow is expressed as

$$Q = \frac{60\dot{m}}{\rho} \quad (27)$$

where

- \dot{m} = mass flow of plume or exhaust air, lb_m/s
- Q = volumetric flow of exhaust gases, cfm
- ρ = density of plume or exhaust gases, lb_m/ft³

Atrium exhaust should equal the mass flow of the plume plus any leakage flow into the atrium above the clear height.

For an atrium with negligible heat loss from the smoke layer and negligible air leakage into the smoke layer from the outside, exhaust

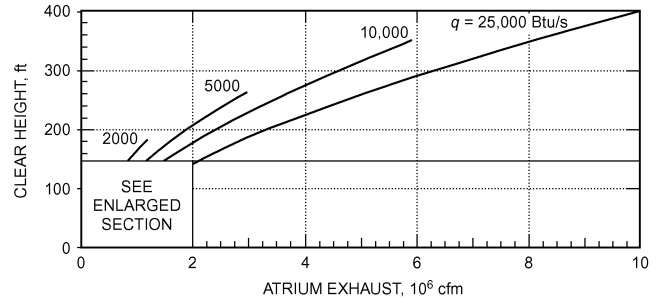

Fig. 22 Atrium Exhaust to Maintain Steady Clear Height

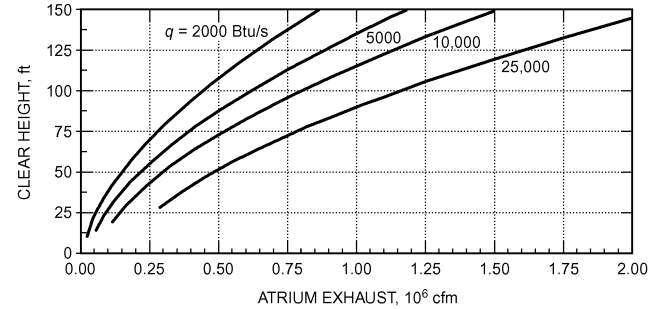

Fig. 23 Enlarged Scale for Figure 22

equals the plume's mass flow rate from Equation (22) at the same temperature as the plume from Equation (25). Figures 22 and 23 show the exhaust rate needed to maintain a constant clear height for an atrium with negligible heat loss from the smoke layer and negligible air leakage into the smoke layer from the outside.

The major assumptions of the analysis plotted in Figures 22 and 23 are as follows:

- Plume has space to flow to top of atrium without obstructions
- Heat release rate of fire is constant
- Clear height is greater than mean flame height
- Smoke layer is adiabatic
- Plume flow and exhaust are the only significant mass flows into or out of smoke layer (i.e., outside airflow, either as leakage or as makeup air, into smoke layer is insignificant)

Minimum Smoke Layer Depth

An atrium smoke management system must be designed with a smoke layer deep enough to accommodate a **ceiling jet**, a radial jet of smoke formed when a plume hits the ceiling. Usual estimates of ceiling jet depth are 10 to 20% of the distance between the base of the fuel and the ceiling (the ceiling jet itself is only about 10% of this distance, but at the walls the jet reverses and flows under itself). Generally, the smoke layer depth should be at least 20% of the distance between the base of the fuel and the ceiling.

Number of Exhaust Inlets

When the flow rate of a smoke exhaust inlet is relatively large, cold air from the lower layer can be pulled into the smoke exhaust. This phenomenon is called **plugholing**. A number of exhaust air inlets may be needed to prevent plugholing. The maximum volumetric flow rate that can be exhausted by a single exhaust inlet without plugholing is calculated by

$$V_{max} = 452\gamma d^{5/2} \left(\frac{T_s - T_o}{T_o} \right)^{1/2} \quad (28)$$

where

V_{max} = maximum volumetric flow rate without plugholing at T_s , cfm
 γ = exhaust location factor, dimensionless
 d = depth of smoke layer below lowest point of exhaust inlet, ft
 T_s = absolute temperature of smoke layer, °R
 T_o = absolute ambient temperature, °R

The ratio d/D_i should be greater than 2 where D_i is the diameter of the of the exhaust inlet. For exhaust inlets centered no closer than $2D_i$ from the nearest wall, $\gamma = 1$ should be used; for less than $2D_i$, $\gamma = 0.5$ should be used. For exhaust inlets on a wall, use $\gamma = 0.5$.

For rectangular exhaust inlets, calculate D_i as

$$D_i = \frac{2ab}{a+b}$$

where

a = length of inlet
 b = width of inlet

Where multiple inlets are needed to prevent plugholing, the minimum separation between inlets should be

$$S_{min} = 0.065 V_e^{1/2}$$

where

S_{min} = minimum edge-to-edge separation between inlets, ft
 V_e = volumetric flow rate of one exhaust inlet, cfm

This approach for calculating V_{max} and S_{min} is consistent with that of NFPA *Standard 92B*. A less conservative approach was in earlier versions of this *Standard* and Klotz and Milke (2002); research is needed to evaluate these approaches.

Separation Between Inlets

When exhaust at an inlet is near the maximum flow rate Q_{max} , adequate separation between exhaust inlets must be maintained to minimize interaction between flows near the inlets. One criterion for separation between inlets is that it be at least the distance from a single inlet that would result in an arbitrarily small velocity based on sink flow. Using 40 fpm as the arbitrary velocity, the minimum separation distance for inlets located in a wall near the ceiling (or in the ceiling near the wall) is

$$S_{min} = 0.023 \beta \sqrt{Q_e} \quad (29)$$

where

S_{min} = minimum separation between inlets, ft
 Q_e = volumetric flow rate, cfm
 β = exhaust location factor, dimensionless

Prestratification and Detection

A layer of hot air often forms under the ceiling of an atrium because of solar radiation on the atrium roof. Although no studies have been made of this **prestratification layer**, building designers indicate that the temperature of such a layer can exceed 120°F. Temperatures below this layer are controlled by the building's heating and cooling system; the temperature can be considered to increase significantly over a small increase in elevation, as shown in [Figure 24](#). The analysis of smoke stratification given in NFPA *Standard 92B* is not appropriate for the temperature profile addressed in this section because it is for a constant temperature increase per unit elevation.

When the average temperature of the plume is lower than that of the prestratification layer, the smoke will form a stratified layer beneath the prestratification layer, as shown in [Figure 25](#). Average plume temperatures can be calculated from Equations (22) and (25); they are plotted in [Figure 21](#), which shows that the average plume

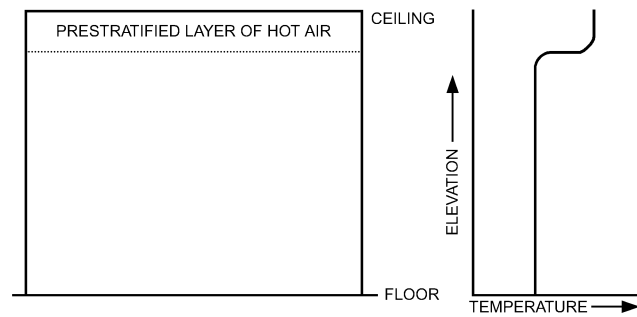

Note: Temperature below the hot layer is controlled by the building's heating and cooling system.

Fig. 24 Prestratified Layer of Hot Air under Atrium Ceiling and Resulting Temperature Profile

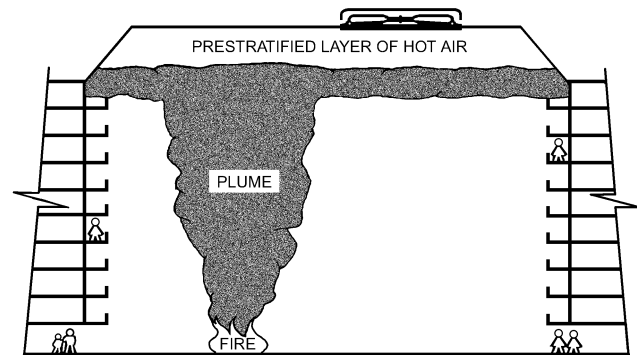

Fig. 25 Smoke Filling a Prestratified Atrium

temperature is usually less than expected temperatures of the hot air layer. Thus, when there is a prestratified layer, smoke cannot be expected to reach the atrium ceiling, and smoke detectors mounted on that ceiling cannot be expected to go into alarm.

Beam smoke detectors can overcome this detection difficulty. The following approaches can provide prompt detection regardless of air temperature under the ceiling when a fire begins:

- **Upward-Angled Beam to Detect Smoke Layer.** One or more beams are aimed upward to intersect the smoke layer regardless of the level of smoke stratification. For redundancy, more than one beam smoke detector is recommended. Advantages include not needing to locate several horizontal beams, and the minimized risk of false activation by sunlight (a risk with some beam smoke detectors) because the receivers are angled downward. [Figure 26](#) illustrates the upward-angled beam approach.
- **Horizontal Beams at Various Levels to Detect Smoke Layer.** One or more beam detectors are located at roof level, with additional detectors at lower levels. Exact beam positioning depends on the specific design, but should include beams at the bottom of identified unconditioned spaces and at or near the design smoke level, with several beams at intermediate positions.
- **Horizontal Beams to Detect Smoke Plume.** Beams are arranged at a level below the lowest expected stratification level. These beams must be close enough to each other to ensure intersection of the plume; spacing should be based on the width of the beam at the least elevation above a point of fire potential.

All components of a beam smoke detector must be accessible for maintenance. For the arrangement shown in [Figure 26](#), a roof opening (not shown) could provide access for maintenance.

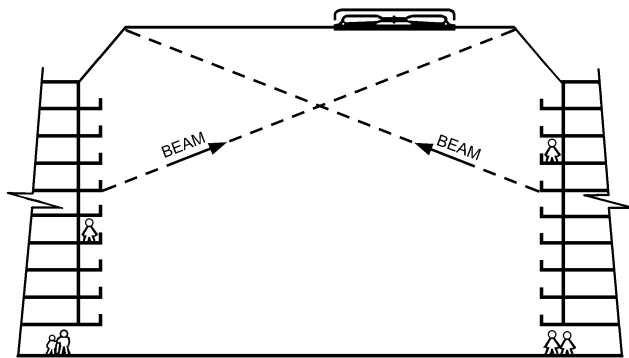

Fig. 26 Beam Detectors Used for Activation of Atrium Smoke Management System

TENABILITY SYSTEMS

The intent of smoke control systems is to provide a tenable environment in the means of egress or other locations during building fires. A **tenable environment** is one in which combustion products, including heat, are limited to a level that is not life threatening. Analysis of a tenability system consists of a smoke transport analysis and a tenability evaluation. For most applications, smoke transport calculations are done by either a computational fluid dynamic (CFD) model or a network model.

Tenability Evaluation

Tenability evaluation considers the effects of exposure to toxic gas, heat, and thermal radiation, as well as reduced visibility. Toxic gas, heat, and thermal radiation exposure are direct threats to life. The severity of each threat depends on the intensity and length of exposure.

Reduced visibility does not directly threaten life, but it is an indirect hazard. Reduced visibility can reduce walking speed. When occupants and firefighters cannot see very much, they often become disoriented and cannot get away from the smoke, thus prolonging their exposure. Another concern is that a disoriented person can fall from an atrium balcony, which can be fatal.

Considerable research has been conducted regarding tenability, and methods are available for calculating exposures to combustion gases and reduced visibility (ISO *Standard* 13571; Jin 2002; Klote and Milke 2002; Purser 2002). There is no broad consensus on visibility criteria, but Jin (2002) suggests 43 ft for applications where occupants are unfamiliar with the building (e.g., museums, casinos), and 13 ft when occupants are familiar with the building (e.g., residential applications). The U.K. Chartered Institution of Building Service Engineers (CIBSE 2003) suggests 26 to 33 ft.

When combustion products from most materials are diluted enough to meet any of these visibility criteria, the hazards to life from toxic gases, heat, and thermal radiation are also eliminated for exposures up to 20 min. This means that, for most fires, tenability can be evaluated by calculating visibility, if the hazards of other exposures are checked.

Atria and Other Large Spaces

For atria and other large spaces, it is appropriate to use a CFD model (see Chapter 34 of the 2005 *ASHRAE Handbook—Fundamentals* for CFD information) to calculate tenability. CFD has been used for a wide range of applications, including aircraft design, automotive design, boiler design, and weather forecasting, and is extensively used for atrium smoke management systems. For examples of CFD simulations of smoke transport in large spaces, see Hadjisophocleous et al. (1999), Kashef et al. (2002), Klote (2005), and Lougheed and Hadjisophocleous (2000).

The idea of CFD is to divide the space of interest into a large number of cells and to solve the governing equations for each cell. For atrium applications, the number of cells typically ranges from 100,000 to 1,000,000. Obstructions such as walls, balconies, and stairs need to be taken into account. Conditions at the boundaries need to be defined. Exhaust flow at or near the top of the atrium is specified, and makeup air conditions are also defined. This allows simulation of fluid flow in considerable detail.

Although CFD modeling has significant advantages in realistically simulating smoke flow, it is computationally intensive and requires a lot of computer memory and time; it is not uncommon for a CFD simulation to run for hours and sometimes days. Because CFD is computationally intensive, it produces so many numbers that the usual ways to evaluate computer output are inappropriate. Visualization methods have been developed so people can understand CFD results.

Several general-purpose CFD models are commercially available that can be used for atrium smoke control. The U.S. National Institute of Standards and Technology (NIST) developed the Fire Dynamics Simulator (FDS) model (McGrattan 2004; McGrattan and Forney 2004), and its visualization software called Smokeview (Forney and McGrattan 2004). The FDS model includes numerous fire-modeling applications, such as smoke plume flow, fires in enclosures, a burning townhouse, sprinklered fires, an oil tank fire, fires in aircraft hangars, rack storage commodity fire, and a brush fire advancing toward a house. FDS and Smokeview can be downloaded free of charge (www.fire.nist.gov/fds).

Large Multicompartmented Buildings

Because of the number of rooms and shafts in large multicompartmented buildings, it is often not feasible to use CFD to simulate smoke transport. Ideally, the model used for such simulations would be able to simulate a fire and mass and heat transfer throughout the building. No practical model can do this, but research is under way to develop such a model. Currently, the network model CONTAM is used to simulate smoke transport in large multicompartmented buildings. See the section on Computer Analysis for Pressurization Systems for more information about CONTAM. Ferreira (2002), Hadjisophocleous et al. (2002), Klote (2002, 2004), and Chapter 9 of Klote and Milke (2002) provide examples of tenability calculations using CONTAM. Because CONTAM requires that temperatures be supplied as data input by the user, the temperatures need to be calculated or estimated by the user.

ACCEPTANCE TESTING

Regardless of the care, skill, and attention to detail with which a smoke control system is designed, an acceptance test is needed as assurance that the system, as built, operates as intended.

An acceptance test should be composed of two levels of testing. The first is functional: an initial check of the system components. The importance of the initial check has become apparent because of problems encountered during tests of smoke control systems: fans operating backward, fans to which no electrical power was supplied, controls that did not work properly, etc.

The second level of testing is of performance, to determine whether the system performs adequately under all required modes of operation. This can consist of measuring pressure differences across barriers under various modes of smoke control system operation. If airflows through open doors are important, these should be measured. Chemical smoke from smoke candles (sometimes called smoke bombs) is not recommended for performance testing because it normally lacks the buoyancy of hot smoke from a real building fire. Smoke near a flaming fire has a temperature of 1000 to 2000°F. Heating chemical smoke to such temperatures to emulate smoke from a real fire is not recommended unless precautions are taken to protect life and property. The same comments about buoyancy apply to tracer gases. Thus, pressure-difference testing is the most

practical performance test. However, chemical smoke can be used to aid flow visualization.

ASHRAE *Guideline 5* covers the commissioning of smoke management systems.

SPECIAL INSPECTOR

Some building codes require special inspection and tests of smoke control systems in addition to the ordinary inspection of and test requirements for buildings, structures, and parts of buildings. These special inspections and tests should verify the proper commissioning of the smoke control design in its final installed condition. Procedures for inspection and testing should be developed by the smoke control system's special inspector, with approval of the authorities having jurisdiction. The special inspector needs to understand the principles of smoke control, including code requirements. The special inspector should check that the components of the system are as specified and that those components are installed as intended, as well as whether the smoke control system performs as intended.

EXTRAORDINARY INCIDENTS

Extraordinary incidents, whether caused by war, terrorism, accident, or natural disaster, can affect immediate human needs such as survival and safety, and also longer-term needs such as air, water, food, and shelter. Some buildings are designed with specific features intended to make them less susceptible to extraordinary incidents. It is recommended that actuation of systems for fire and smoke protection be of higher priority than possibly conflicting automatic strategies designed to respond to other extraordinary conditions.

Some acts of terrorism use fire, and those using bombs often lead to fires. It is well known that war, terrorist attacks, and natural disasters have the potential to disrupt utilities and interfere with fire fighting, and this often permits any fires that occur to grow unchecked. For these reasons, simultaneous fire and other extraordinary incidents should be considered likely, and any features intended to mitigate extraordinary conditions should be designed accordingly. For more information, see ASHRAE's (2003) report, *Risk Management Guidance for Health, Safety and Environmental Security under Extraordinary Incidents* and [Chapter 58](#) of this volume.

SYMBOLS

A	= area, ft ²
a	= dilution rate, air changes per minute
A_{bo}	= flow area between building and outside (per floor), ft ²
A_f	= area of floor, ft ²
A_{sb}	= flow area between stairwell and building (per floor), ft ²
A_w	= area of wall, ft ²
B	= $7.64(1/T_o - 1/T_g)$ at sea level standard pressure
C	= concentration of contaminant at initial time θ ; flow coefficient
C_o	= initial concentration of contaminant
c_p	= specific heat of plume gases, Btu/lb·°F
C_w	= pressure coefficient, dimensionless
d	= distance from doorknob to edge of knob side of door, ft
e	= base of natural logarithm (approximately 2.718)
F	= total door-opening force, lb _f
F_{dc}	= force to overcome door closer, lb _f
i	= floor-to-ceiling height, or ceiling height above fire, ft
H_j	= thickness of ceiling jet, ft
h	= distance above neutral plane, ft
\dot{m}	= mass flow of plume or exhaust air, lb _m /s
i	= number of floors
p	= absolute pressure, lb _f /ft ²
p_w	= pressure exerted by wind, in. of water
Q	= volumetric flow rate, cfm
q	= heat release rate of fire, Btu/s

q_c	= heat release rate, Btu/h or Btu/s
Q_e	= volumetric flow rate, cfm
Q_{in}	= volumetric flow rate of air into fire compartment, cfm
Q_{out}	= volumetric flow rate of smoke out of fire compartment, cfm
R	= gas constant, ft·lb _f /lb _m ·°R
S_{min}	= minimum separation between inlets, ft
T	= absolute temperature of smoke gases, °R
t	= time, min or s
T_a	= ambient temperature, °R
T_f	= average absolute temperature of fire compartment, °R
t_g	= growth time, s
T_i	= absolute temperature of air inside shaft, °R
T_{in}	= absolute temperature of air into fire compartment, °R
T_j	= absolute temperature of ceiling jet, °R
T_o	= absolute temperature of outside air, °R
T_{out}	= absolute temperature of smoke leaving fire compartment, °R
T_p	= plume temperature at clear height, °R
T_s	= absolute temperature of stairwell air or surroundings, °R
V	= wind velocity, mph
V_k	= critical air velocity to prevent smoke backflow, fpm
W	= corridor or door width, ft
y	= distance above stairwell bottom, ft
z	= height of first indication of smoke above fire, or clear height above top of fuel, ft
z_f	= mean flame height, ft

Greek

β	= exhaust location factor, dimensionless
Δp	= pressure difference, in. of water
Δp_{sb}	= pressure difference between stairwell and building, in. of water
Δp_{sbb}	= pressure difference between stairwell and building at stairwell bottom, in. of water
Δp_{sbt}	= pressure difference from stairwell to building at stairwell top, in. of water
θ	= time
ρ	= density, lb _m /ft ³
ρ_o	= outside air density, lb _m /ft ³
ξ	= convective fraction of heat release

REFERENCES

- AMCA. 2007. Certified ratings program—Product rating manual for smoke management fan performance. *Publication 212-07*. Air Movement and Control Association, Arlington Heights, IL.
- ASHRAE. 2000. Laboratory methods of testing fans used to exhaust smoke in smoke management systems. *ANSI/ASHRAE Standard 149-2000 (RA 2005)*.
- ASHRAE. 1994. Commissioning of smoke management systems. *Guideline 5*.
- ASHRAE. 2003. Risk management guidance for health, safety and environmental security under extraordinary incidents. *Report*, Presidential Ad Hoc Committee for Building Health and Safety under Extraordinary Incidents.
- ASTM. 2002. Test method for fire tests of through-penetration fire stops. *Standard E814*. American Society for Testing and Materials, West Conshohocken, PA.
- Bukowski, R.W. 1991. Fire models, the future is now! *NFPA Journal* 85(2): 60-69.
- CIBSE. 2003. Fire engineering. *CIBSE Guide E*, 2nd ed. Chartered Institution of Building Services Engineers, London.
- Cooper, L.Y. 1985. ASET—A computer program for calculating available safe egress time. *Fire Safety Journal* 9:29-45.
- Cooper, L.Y. and G.P. Forney. 1987. Fire in a room with a hole: A prototype application of the consolidated compartment fire model (CCFM) computer code. Presented at the 1987 Combined Meetings of Eastern Section of Combustion Institute and NBS Annual Conference on Fire Research.
- Cresci, R.J. 1973. Smoke and fire control in high-rise office buildings—Part II, Analysis of stair pressurization systems. Symposium on Experience and Applications on Smoke and Fire Control, ASHRAE Annual Meeting, June.

- Evers, E. and A. Waterhouse. 1978. *A computer model for analyzing smoke movement in buildings*. Building Research Establishment, Fire Research Station, Borehamwood, Hertsfordshire, U.K.
- Fang, J.B. 1980. *Static pressures produced by room fires*. NBSIR 80-1984. National Bureau of Standards. Available from National Institute of Standards and Technology, Gaithersburg, MD.
- Fang, J.B. and J.N. Breese. 1980. *Fire development in residential basement rooms*. NBSIR 80-2120. National Bureau of Standards. Available from National Institute of Standards and Technology, Gaithersburg, MD.
- Ferreira, M.J. 2002. Use of multizone modeling for high-rise smoke control system design. *ASHRAE Transactions* 108(2):837-846.
- Forney, G.P. and K. McGrattan. 2004. User's guide for Smokeview version 4—A tool for visualizing fire dynamics simulation data. NIST *Special Publication* 1017. National Institute of Standards and Technology, Gaithersburg, MD.
- Hadjisophocleous, G.V., G.D. Lougheed, and S. Cao. 1999. Numerical study of the effectiveness of atrium smoke exhaust systems. *ASHRAE Transactions* 105(1):699-715.
- Hadjisophocleous, G., F. Zhuman, and G. Lougheed. 2002. Computational and experimental study of smoke flow in the stair shaft of a 10-story tower. *ASHRAE Transactions* 108(1):724-730.
- Houghton, E.L. and N.B. Carruther. 1976. *Wind forces on buildings and structures*. John Wiley & Sons, New York.
- Huggett, C. 1980. Estimation of heat release by means of oxygen consumption measurements. *Fire and Materials* 4(2).
- ISO. 2002. Life-threatening components of fire—Guidelines for the estimation of time available for escape using fire data. ISO/TS *Standard* 13571. International Organization for Standardization, Geneva.
- Jin, T. 2002. *SFPE handbook of fire protection engineering*, Ch. 2-4, Visibility and human behavior in fire smoke. Society of Fire Protection Engineers, Bethesda, MD.
- Jones, W.W. 1983. *A review of compartment fire models*. NBSIR 83-2684. National Bureau of Standards. Available from National Institute of Standards and Technology, Gaithersburg, MD.
- Kashef, A., N. Benichou, G.D. Lougheed, and C. McCartney. 2002. A computational and experimental study of fire growth and smoke movement in large spaces. *10th Annual Conference of the Computational Fluid Dynamics Society of Canada*, Windsor, Ontario, pp. 1-6.
- Klote, J.H. 1980. Stairwell pressurization. *ASHRAE Transactions* 86(1): 604-673.
- Klote, J.H. 1982. *A computer program for analysis of smoke control systems*. NBSIR 82-2512. National Bureau of Standards. Available from National Institute of Standards and Technology, Gaithersburg, MD.
- Klote, J.H. 1984. Smoke control for elevators. *ASHRAE Journal* 26(4): 23-33.
- Klote, J.H. 1990. Fire experiments of zoned smoke control at the Plaza Hotel in Washington, D.C. *ASHRAE Transactions* 96(2):399-416.
- Klote, J.H. 2002. Smoke management applications of CONTAM. *ASHRAE Transactions* 108(2):827-836.
- Klote, J.H. 2004. Tenability and open doors in pressurized stairwells. *ASHRAE Transactions* 110(1):613-637.
- Klote, J.H. 2005. CFD analysis of atrium smoke control at the Newseum. *ASHRAE Transactions* 111(2):567-574.
- Klote, J.H. and X. Bodart. 1985. Validation of network models for smoke control analysis. *ASHRAE Transactions* 91(2B):1134-1145.
- Klote, J.H. and J.A. Milke. 2002. *Principles of smoke management*. ASHRAE.
- Klote, J.H. and G.T. Tamura. 1986. Smoke control and fire evacuation by elevators. *ASHRAE Transactions* 92(1).
- Law, M. 1982. Air-supported structures: Fire and smoke hazards. *Fire Prevention* 148:24-28.
- Lougheed, G.D. and G.V. Hadjisophocleous. 2000. The smoke hazard from a fire in high spaces. *ASHRAE Transactions* 107(1):720-729.
- MacDonald, A.J. 1975. *Wind loading on buildings*. John Wiley & Sons, New York.
- McGrattan, K. 2004. Fire Dynamics Simulator (version 4)—Technical reference guide. NIST *Special Publication* 1018. National Institute of Standards and Technology, Gaithersburg, MD.
- McGrattan, K. and G.P. Forney. 2004. Fire Dynamics Simulator (version 4)—User's guide. NIST *Special Publication* 1019. National Institute of Standards and Technology, Gaithersburg, MD.
- McGuire, J.H. and G.T. Tamura. 1975. Simple analysis of smoke flow problems in high buildings. *Fire Technology* 11(1):15-22.
- McGuire, J.H., G.T. Tamura, and A.G. Wilson. 1970. Factors in controlling smoke in high buildings. Symposium on Fire Hazards in Buildings, ASHRAE Winter Meeting.
- Milke, J.A. and F.W. Mowrer. 1994. Computer-aided design for smoke management in atria and covered malls. *ASHRAE Transactions* 100(2): 448-456.
- Mitler, H.E. 1984. Zone modeling of forced ventilation fires. *Combustion Science and Technology* 39:83-106.
- Mitler, H.E. 1985. *Comparison of several compartment fire models: An interim report*. NBSIR 85-3233. National Bureau of Standards. Available from National Institute of Standards and Technology, Gaithersburg, MD.
- Mitler, H.E. and H.W. Emmons. 1981. Documentation for CFC V, the fifth Harvard computer code. Home Fire Project *Technical Report* 45. Harvard University, Cambridge, MA.
- Mitler, H.E. and J.A. Rockett. 1986. *How accurate is mathematical fire modeling?* NBSIR 86-3459. National Bureau of Standards. Available from National Institute of Standards and Technology, Gaithersburg, MD.
- Morgan, H.P. 1979. *Smoke control methods in enclosed shopping complexes of one or more stories: A design summary*. Fire Research Station, Borehamwood, Hertsfordshire, U.K.
- Morgan, H.P. and G.O. Hansell. 1987. Atrium buildings: Calculating smoke flows in atria for smoke control design. *Fire Safety Journal* 12:9-12.
- Nelson, H.E. 1987. *An engineering analysis of the early stages of fire development—The fire at the Dupont Plaza Hotel and Casino—Dec. 31, 1986*. NISTIR 87-3560. National Institute of Standards and Technology, Gaithersburg, MD.
- Nelson, H.E. and F.W. Mowrer. 2002. *SFPE handbook of fire protection engineering*, Ch. 3-14, Emergency movement. Society of Fire Protection Engineers, Bethesda, MD.
- NFPA. 2002. Installation of air-conditioning and ventilating systems. *Standard* 90A-02. National Fire Protection Association, Quincy, MA.
- NFPA. 2006. Recommended practice for smoke-control systems. *Standard* 92A. National Fire Protection Association, Quincy, MA.
- NFPA. 2005. Standard for smoke management systems in malls, atria, and large areas. *Standard* 92B. National Fire Protection Association, Quincy, MA.
- NFPA. 2006. *Life safety code*®. *Standard* 101. National Fire Protection Association, Quincy, MA.
- NFPA. 2002. Guide for smoke and heat venting. *Standard* 204. National Fire Protection Association, Quincy, MA.
- NFPA. 2003. *Fire protection handbook*, 19th ed. National Fire Protection Association, Quincy, MA.
- NOAA. 1979. *Temperature extremes in the United States*. National Oceanic and Atmospheric Administration (U.S.), National Climatic Center, Asheville, NC.
- Peacock, R.D., G.P. Forney, P. Reneke, R. Portier, and W.W. Jones. 1993. CFAST, the consolidated model of fire growth and smoke transport. NIST *Technical Note* 1299. National Institute of Standards and Technology, Gaithersburg, MD.
- Proulx, G. 2002. *SFPE handbook of fire protection engineering*, Ch. 3-13, Movement of people: The evacuation timing. Society of Fire Protection Engineers, Bethesda, MD.
- Purser, D.A. 2002. *SFPE handbook of fire protection engineering*, Ch. 2-6, Toxicity assessment of combustion products. Society of Fire Protection Engineers, Bethesda, MD.
- Quintiere, J.G. 1989. Fundamentals of enclosure fire “zone” models. *Journal of Fire Protection Engineering* 1(3):99-119.
- Rilling, J. 1978. *Smoke study, 3rd phase: Method of calculating the smoke movement between building spaces*. Centre Scientifique et Technique du Bâtiment (CSTB), Champs sur Marne, France.
- Sachs, P. 1972. *Wind forces in engineering*. Pergamon, New York.
- Said, M.N.A. 1988. A review of smoke control models. *ASHRAE Journal* 30(4):36-40.
- Sander, D.M. 1974. FORTRAN IV program to calculate air infiltration in buildings. DBR *Computer Program* 37. National Research Council, Ottawa, Canada.
- Sander, D.M. and G.T. Tamura. 1973. FORTRAN IV program to simulate air movement in multi-story buildings. DBR *Computer Program* 35. National Research Council, Ottawa, Canada.
- Shaw, C.Y., J.T. Reardon, and M.S. Cheung. 1993. Changes in air leakage levels of six Canadian office buildings. *ASHRAE Journal* 35(2):34-36.
- Shaw, C.Y. and G.T. Tamura. 1977. The calculation of air infiltration rates caused by wind and stack action for tall buildings. *ASHRAE Transactions* 83(2):145-158.

- Simiu, E. and R.H. Scanlan. 1978. *Wind effects on structures: An introduction to wind engineering*. John Wiley & Sons, New York.
- Tamura, G.T. 1990. Field tests of stair pressurization systems with overpressure relief. *ASHRAE Transactions* 96(1):951-958.
- Tamura, G.T. 1994. *Smoke movement and control in high-rise buildings*. National Fire Protection Association, Quincy, MA.
- Tamura, G.T. and C.Y. Shaw. 1976a. Studies on exterior wall air tightness and air infiltration of tall buildings. *ASHRAE Transactions* 83(1):122-134.
- Tamura, G.T. and C.Y. Shaw. 1976b. Air leakage data for the design of elevator and stair shaft pressurization systems. *ASHRAE Transactions* 83(2):179-190.
- Tamura, G.T. and C.Y. Shaw. 1978. Experimental studies of mechanical venting for smoke control in tall office buildings. *ASHRAE Transactions* 86(1):54-71.
- Tamura, G.T. and A.G. Wilson. 1966. Pressure differences for a 9-story building as a result of chimney effect and ventilation system operation. *ASHRAE Transactions* 72(1):180-189.
- Tanaka, T. 1983. *A model of multiroom fire spread*. NBSIR 83-2718. National Bureau of Standards. Available from National Institute of Standards and Technology, Gaithersburg, MD.
- Thomas, P.H. 1970. Movement of smoke in horizontal corridors against an airflow. *Institution of Fire Engineers Quarterly* 30(77):45-53.
- UL. 1999. Fire dampers. *ANSI/UL Standard 555-99*. Underwriters Laboratories, Northbrook, IL.
- UL. 1999. Smoke dampers. *ANSI/UL Standard 555S-99*. Underwriters Laboratories, Northbrook, IL.
- UL. 2003. Fire tests of through-penetration firestops. *ANSI/UL Standard 1479-03*. Underwriters Laboratories, Northbrook, IL.
- Wakamatsu, T. 1977. Calculation methods for predicting smoke movement in building fires and designing smoke control systems. In *Fire Standards and Safety*, ASTM STP 614, pp. 168-193. American Society for Testing and Materials, West Conshohocken, PA.
- Walton, G.N. 1989. *AIRNET—A computer program for building airflow network modeling*. National Institute of Standards and Technology, Gaithersburg, MD.
- Walton, W.D. 1985. *ASET-B: A room fire program for personal computers*. NBSIR 85-3144-1. National Bureau of Standards. Available from National Institute of Standards and Technology, Gaithersburg, MD.
- Walton, G.N. and W.S. Dols. 2005. *CONTAM 2.4 user guide and program documentation*. NISTIR 7251. National Institute of Standards and Technology, Gaithersburg, MD.
- Wray, C.P. and G.K. Yuill. 1993. An evaluation of algorithms for analyzing smoke control systems. *ASHRAE Transactions* 99(1):160-174.
- Yoshida, H., C.Y. Shaw, and G.T. Tamura. 1979. A FORTRAN IV program to calculate smoke concentrations in a multi-story building. *DBR Computer Program 45*. National Research Council, Ottawa, Canada.

BIBLIOGRAPHY

- CIBSE. 1995. *Relationships for smoke control calculations*. TM19:1995. Chartered Institution of Building Service Engineers, London.
- Lougheed, G.D. and G.V. Hadjisophocleous. 1997. Investigation of atrium smoke exhaust effectiveness. *ASHRAE Transactions* 103(2):519-533.
- Sprat, D. and A.J.M. Heselden. 1974. Efficient extraction of smoke from a thin layer under a ceiling. *Fire Research Note* 1001.

[Related Commercial Resources](#)