

CHAPTER 18

NONRESIDENTIAL COOLING AND HEATING LOAD CALCULATIONS

<i>Cooling Load Calculation Principles</i>	18.1	<i>Heating Load Calculations</i>	18.28
<i>Internal Heat Gains</i>	18.3	<i>System Heating and Cooling Load Effects</i>	18.32
<i>Infiltration and Moisture Migration Heat Gains</i>	18.11	<i>Example Cooling and Heating Load Calculations</i>	18.36
<i>Fenestration Heat Gain</i>	18.14	<i>Previous Cooling Load Calculation Methods</i>	18.49
<i>Heat Balance Method</i>	18.15	<i>Building Example Drawings</i>	18.55
<i>Radiant Time Series (RTS) Method</i>	18.20		

HEATING and cooling load calculations are the primary design basis for most heating and air-conditioning systems and components. These calculations affect the size of piping, ductwork, diffusers, air handlers, boilers, chillers, coils, compressors, fans, and every other component of systems that condition indoor environments. Cooling and heating load calculations can significantly affect first cost of building construction, comfort and productivity of occupants, and operating cost and energy consumption.

Simply put, heating and cooling loads are the rates of energy input (heating) or removal (cooling) required to maintain an indoor environment at a desired temperature and humidity condition. Heating and air conditioning systems are designed, sized, and controlled to accomplish that energy transfer. The amount of heating or cooling required at any particular time varies widely, depending on external (e.g., outside temperature) and internal (e.g., number of people occupying a space) factors.

Peak design heating and cooling load calculations, which are this chapter’s focus, seek to determine the maximum rate of heating and cooling energy transfer needed at any point in time. Similar principles, but with different assumptions, data, and application, can be used to estimate building energy consumption, as described in Chapter 19.

This chapter discusses common elements of cooling load calculation (e.g., internal heat gain, ventilation and infiltration, moisture migration, fenestration heat gain) and two methods of heating and cooling load estimation: heat balance (HB) and radiant time series (RTS).

COOLING LOAD CALCULATION PRINCIPLES

Cooling loads result from many conduction, convection, and radiation heat transfer processes through the building envelope and from internal sources and system components. Building components or contents that may affect cooling loads include the following:

- **External:** Walls, roofs, windows, skylights, doors, partitions, ceilings, and floors
- **Internal:** Lights, people, appliances, and equipment
- **Infiltration:** Air leakage and moisture migration
- **System:** Outside air, duct leakage and heat gain, reheat, fan and pump energy, and energy recovery

TERMINOLOGY

The variables affecting cooling load calculations are numerous, often difficult to define precisely, and always intricately interrelated. Many cooling load components vary widely in magnitude,

and possibly direction, during a 24 h period. Because these cyclic changes in load components often are not in phase with each other, each component must be analyzed to establish the maximum cooling load for a building or zone. A **zoned system** (i.e., one serving several independent areas, each with its own temperature control) needs to provide no greater total cooling load capacity than the largest hourly sum of simultaneous zone loads throughout a design day; however, it must handle the peak cooling load for each zone at its individual peak hour. At some times of day during heating or intermediate seasons, some zones may require heating while others require cooling. The zones’ ventilation, humidification, or dehumidification needs must also be considered.

Heat Flow Rates

In air-conditioning design, the following four related heat flow rates, each of which varies with time, must be differentiated.

Space Heat Gain. This instantaneous rate of heat gain is the rate at which heat enters into and/or is generated within a space. Heat gain is classified by its mode of entry into the space and whether it is sensible or latent. **Entry modes** include (1) solar radiation through transparent surfaces; (2) heat conduction through exterior walls and roofs; (3) heat conduction through ceilings, floors, and interior partitions; (4) heat generated in the space by occupants, lights, and appliances; (5) energy transfer through direct-with-space ventilation and infiltration of outdoor air; and (6) miscellaneous heat gains. **Sensible heat** is added directly to the conditioned space by conduction, convection, and/or radiation. **Latent heat gain** occurs when moisture is added to the space (e.g., from vapor emitted by occupants and equipment). To maintain a constant humidity ratio, water vapor must condense on the cooling apparatus and be removed at the same rate it is added to the space. The amount of energy required to offset latent heat gain essentially equals the product of the condensation rate and latent heat of condensation. In selecting cooling equipment, distinguish between sensible and latent heat gain: every cooling apparatus has different maximum removal capacities for sensible versus latent heat for particular operating conditions. In extremely dry climates, humidification may be required, rather than dehumidification, to maintain thermal comfort.

Radiant Heat Gain. Radiant energy must first be absorbed by surfaces that enclose the space (walls, floor, and ceiling) and objects in the space (furniture, etc.). When these surfaces and objects become warmer than the surrounding air, some of their heat transfers to the air by convection. The composite heat storage capacity of these surfaces and objects determines the rate at which their respective surface temperatures increase for a given radiant input, and thus governs the relationship between the radiant portion of heat gain and its corresponding part of the space cooling load (Figure 1). The thermal storage effect is critical in differentiating between instantaneous heat gain for a given space and its cooling load at that moment. Predicting the nature and magnitude of this phenomenon in order to estimate a realistic cooling load for a particular set of circumstances has long

The preparation of this chapter is assigned to TC 4.1, Load Calculation Data and Procedures.

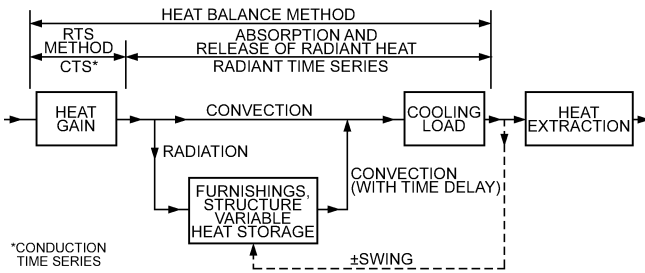

Fig. 1 Origin of Difference Between Magnitude of Instantaneous Heat Gain and Instantaneous Cooling Load

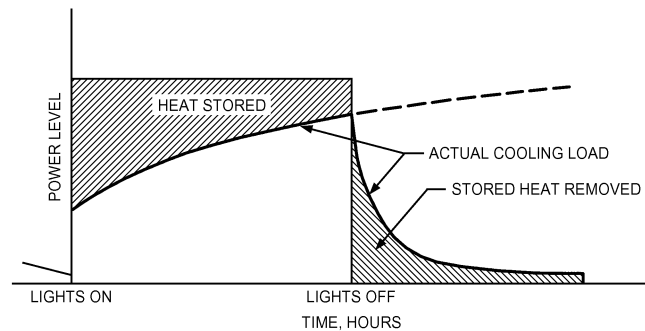

Fig. 2 Thermal Storage Effect in Cooling Load from Lights

been of interest to design engineers; the Bibliography lists some early work on the subject.

Space Cooling Load. This is the rate at which sensible and latent heat must be removed from the space to maintain a constant space air temperature and humidity. The sum of all space instantaneous heat gains at any given time does not necessarily (or even frequently) equal the cooling load for the space at that same time.

Space Heat Extraction Rate. The rates at which sensible and latent heat are removed from the conditioned space equal the space cooling load only if the room air temperature and humidity are constant. Along with the intermittent operation of cooling equipment, control systems usually allow a minor cyclic variation or swing in room temperature; humidity is often allowed to float, but it can be controlled. Therefore, proper simulation of the control system gives a more realistic value of energy removal over a fixed period than using values of the space cooling load. However, this is primarily important for estimating energy use over time; it is not needed to calculate design peak cooling load for equipment selection.

Cooling Coil Load. The rate at which energy is removed at a cooling coil serving one or more conditioned spaces equals the sum of instantaneous space cooling loads (or space heat extraction rate, if it is assumed that space temperature and humidity vary) for all spaces served by the coil, plus any system loads. System loads include fan heat gain, duct heat gain, and outdoor air heat and moisture brought into the cooling equipment to satisfy the ventilation air requirement.

Time Delay Effect

Energy absorbed by walls, floor, furniture, etc., contributes to space cooling load only after a time lag. Some of this energy is still present and reradiating even after the heat sources have been switched off or removed, as shown in Figure 2.

There is always significant delay between the time a heat source is activated, and the point when reradiated energy equals that being instantaneously stored. This time lag must be considered when calculating cooling load, because the load required for the space can be much lower than the instantaneous heat gain being generated, and the space's peak load may be significantly affected.

Accounting for the time delay effect is the major challenge in cooling load calculations. Several methods, including the two presented in this chapter, have been developed to take the time delay effect into consideration.

COOLING LOAD CALCULATION METHODS

This chapter presents two load calculation methods that vary significantly from previous methods. The technology involved, however (the principle of calculating a heat balance for a given space) is not new. The first of the two methods is the **heat balance (HB) method**; the second is **radiant time series (RTS)**, which is a simplification of the HB procedure. Both methods are explained in their respective sections.

Cooling load calculation of an actual, multiple-room building requires a complex computer program implementing the principles of either method.

Cooling Load Calculations in Practice

Load calculations should accurately describe the building. All load calculation inputs should be as accurate as reasonable, without using safety factors. Introducing compounding safety factors at multiple levels in the load calculation results in an unrealistic and oversized load.

Variation in heat transmission coefficients of typical building materials and composite assemblies, differing motivations and skills of those who construct the building, unknown filtration rates, and the manner in which the building is actually operated are some of the variables that make precise calculation impossible. Even if the designer uses reasonable procedures to account for these factors, the calculation can never be more than a good estimate of the actual load. Frequently, a cooling load must be calculated before every parameter in the conditioned space can be properly or completely defined. An example is a cooling load estimate for a new building with many floors of unleased spaces for which detailed partition requirements, furnishings, lighting, and layout cannot be pre-defined. Potential tenant modifications once the building is occupied also must be considered. Load estimating requires proper engineering judgment that includes a thorough understanding of heat balance fundamentals.

Perimeter spaces exposed to high solar heat gain often need cooling during sunlit portions of traditional heating months, as do completely interior spaces with significant internal heat gain. These spaces can also have significant heating loads during nonsunlit hours or after periods of nonoccupancy, when adjacent spaces have cooled below interior design temperatures. The heating loads involved can be estimated conventionally to offset or to compensate for them and prevent overheating, but they have no direct relationship to the spaces' design heating loads.

Correct design and sizing of air-conditioning systems require more than calculation of the cooling load in the space to be conditioned. The type of air-conditioning system, ventilation rate, reheat, fan energy, fan location, duct heat loss and gain, duct leakage, heat extraction lighting systems, type of return air system, and any sensible or latent heat recovery all affect system load and component sizing. Adequate system design and component sizing require that system performance be analyzed as a series of psychrometric processes.

System design could be driven by either sensible or latent load, and both need to be checked. When a space is sensible-load-driven, which is generally the case, the cooling supply air will have surplus capacity to dehumidify, but this is commonly permissible. For a space driven by latent load, (e.g., an auditorium), supply airflow based on sensible load is likely not have enough dehumidifying capability, so subcooling and reheating or some other dehumidification process is needed.

This chapter is primarily concerned with a given space or zone in a building. When estimating loads for a group of spaces (e.g., for an

air-handling system that serves multiple zones), the assembled zones must be analyzed to consider (1) the simultaneous effects taking place; (2) any diversification of heat gains for occupants, lighting, or other internal load sources; (3) ventilation; and/or (4) any other unique circumstances. With large buildings that involve more than a single HVAC system, simultaneous loads and any additional diversity also must be considered when designing the central equipment that serves the systems. Methods presented in this chapter are expressed as hourly load summaries, reflecting 24 h input schedules and profiles of the individual load variables. Specific systems and applications may require different profiles.

DATA ASSEMBLY

Calculating space cooling loads requires detailed building design information and weather data at design conditions. Generally, the following information should be compiled.

Building Characteristics. Building materials, component size, external surface colors, and shape are usually determined from building plans and specifications.

Configuration. Determine building location, orientation, and external shading from building plans and specifications. Shading from adjacent buildings can be determined from a site plan or by visiting the proposed site, but its probable permanence should be carefully evaluated before it is included in the calculation. The possibility of abnormally high ground-reflected solar radiation (e.g., from adjacent water, sand, or parking lots) or solar load from adjacent reflective buildings should not be overlooked.

Outdoor Design Conditions. Obtain appropriate weather data, and select outdoor design conditions. Chapter 14 provides information for many weather stations; note, however, that these design dry-bulb and mean coincident wet-bulb temperatures may vary considerably from data traditionally used in various areas. Use judgment to ensure that results are consistent with expectations. Also, consider prevailing wind velocity and the relationship of a project site to the selected weather station.

Recent research projects have greatly expanded the amount of available weather data (e.g., ASHRAE 2004). In addition to the conventional dry-bulb with mean coincident wet-bulb, data are now available for wet-bulb and dew point with mean coincident dry-bulb. Peak space load generally coincides with peak solar or peak dry-bulb, but peak system load often occurs at peak wet-bulb temperature. The relationship between space and system loads is discussed further in following sections of the chapter.

To estimate conductive heat gain through exterior surfaces and infiltration and outdoor air loads at any time, applicable outdoor dry- and wet-bulb temperatures must be used. Chapter 14 gives monthly cooling load design values of outdoor conditions for many locations. These are generally midafternoon conditions; for other times of day, the daily range profile method described in Chapter 14 can be used to estimate dry- and wet-bulb temperatures. Peak cooling load is often determined by solar heat gain through fenestration; this peak may occur in winter months and/or at a time of day when outside air temperature is not at its maximum.

Indoor Design Conditions. Select indoor dry-bulb temperature, indoor relative humidity, and ventilation rate. Include permissible variations and control limits. Consult ASHRAE *Standard* 90.1 for energy-savings conditions, and *Standard* 55 for ranges of indoor conditions needed for thermal comfort.

Internal Heat Gains and Operating Schedules. Obtain planned density and a proposed schedule of lighting, occupancy, internal equipment, appliances, and processes that contribute to the internal thermal load.

Areas. Use consistent methods for calculation of building areas. For fenestration, the definition of a component's area must be consistent with associated ratings.

Gross surface area. It is efficient and conservative to derive gross surface areas from outside building dimensions, ignoring wall and floor thicknesses and avoiding separate accounting of floor edge and wall corner conditions. Measure floor areas to the outside of adjacent exterior walls or to the center line of adjacent partitions. When apportioning to rooms, façade area should be divided at partition center lines. Wall height should be taken as floor-to-floor height.

The outside-dimension procedure is expedient for load calculations, but it is not consistent with rigorous definitions used in building-related standards. The resulting differences do not introduce significant errors in this chapter's procedures.

Fenestration area. As discussed in Chapter 15, fenestration ratings [U-factor and solar heat gain coefficient (SHGC)] are based on the entire product area, including frames. Thus, for load calculations, fenestration area is the area of the rough opening in the wall or roof.

Net surface area. Net surface area is the gross surface area less any enclosed fenestration area.

INTERNAL HEAT GAINS

Internal heat gains from people, lights, motors, appliances, and equipment can contribute the majority of the cooling load in a modern building. As building envelopes have improved in response to more restrictive energy codes, internal loads have increased because of factors such as increased use of computers and the advent of dense-occupancy spaces (e.g., call centers). Internal heat gain calculation techniques are identical for both heat balance (HB) and radiant time series (RTS) cooling-load calculation methods, so internal heat gain data are presented here independent of calculation methods.

PEOPLE

Table 1 gives representative rates at which sensible heat and moisture are emitted by humans in different states of activity. In high-density spaces, such as auditoriums, these sensible and latent heat gains comprise a large fraction of the total load. Even for short-term occupancy, the extra sensible heat and moisture introduced by people may be significant. See Chapter 9 for detailed information; however, Table 1 summarizes design data for common conditions.

The conversion of sensible heat gain from people to space cooling load is affected by the thermal storage characteristics of that space because some percentage of the sensible load is radiant energy. Latent heat gains are usually considered instantaneous, but research is yielding practical models and data for the latent heat storage of and release from common building materials.

LIGHTING

Because lighting is often a major space cooling load component, an accurate estimate of the space heat gain it imposes is needed. Calculation of this load component is not straightforward; the rate of cooling load from lighting at any given moment can be quite different from the heat equivalent of power supplied instantaneously to those lights, because of heat storage.

Instantaneous Heat Gain from Lighting

The primary source of heat from lighting comes from light-emitting elements, or lamps, although significant additional heat may be generated from ballasts and other appurtenances in the luminaires. Generally, the instantaneous rate of sensible heat gain from electric lighting may be calculated from

$$q_{el} = 3.41 WF_{ul}F_{sa} \tag{1}$$

where

- q_{el} = heat gain, Btu/h
- W = total light wattage, W
- F_{ul} = lighting use factor
- F_{sa} = lighting special allowance factor
- 3.41 = conversion factor

Table 1 Representative Rates at Which Heat and Moisture Are Given Off by Human Beings in Different States of Activity

Degree of Activity	Location	Total Heat, Btu/h		Sensible Heat, Btu/h	Latent Heat, Btu/h	% Sensible Heat that is Radiant ^b	
		Adult Male	Adjusted, M/F ^a			Low <i>V</i>	High <i>V</i>
Seated at theater	Theater, matinee	390	330	225	105		
Seated at theater, night	Theater, night	390	350	245	105	60	27
Seated, very light work	Offices, hotels, apartments	450	400	245	155		
Moderately active office work	Offices, hotels, apartments	475	450	250	200		
Standing, light work; walking	Department store; retail store	550	450	250	200	58	38
Walking, standing	Drug store, bank	550	500	250	250		
Sedentary work	Restaurant ^c	490	550	275	275		
Light bench work	Factory	800	750	275	475		
Moderate dancing	Dance hall	900	850	305	545	49	35
Walking 3 mph; light machine work	Factory	1000	1000	375	625		
Bowling ^d	Bowling alley	1500	1450	580	870		
Heavy work	Factory	1500	1450	580	870	54	19
Heavy machine work; lifting	Factory	1600	1600	635	965		
Athletics	Gymnasium	2000	1800	710	1090		

Notes:

1. Tabulated values are based on 75°F room dry-bulb temperature. For 80°F room dry bulb, total heat remains the same, but sensible heat values should be decreased by approximately 20%, and latent heat values increased accordingly.
2. Also see Table 4, Chapter 9, for additional rates of metabolic heat generation.
3. All values are rounded to nearest 5 Btu/h.

^aAdjusted heat gain is based on normal percentage of men, women, and children for the application listed, and assumes that gain from an adult female is

85% of that for an adult male, and gain from a child is 75% of that for an adult male.

^bValues approximated from data in Table 6, Chapter 9, where *V* is air velocity with limits shown in that table.

^cAdjusted heat gain includes 60 Btu/h for food per individual (30 Btu/h sensible and 30 Btu/h latent).

^dFigure one person per alley actually bowling, and all others as sitting (400 Btu/h) or standing or walking slowly (550 Btu/h).

The **total light wattage** is obtained from the ratings of all lamps installed, both for general illumination and for display use. Ballasts are not included, but are addressed by a separate factor. Wattages of magnetic ballasts are significant; the energy consumption of high-efficiency electronic ballasts might be insignificant compared to that of the lamps.

The **lighting use factor** is the ratio of wattage in use, for the conditions under which the load estimate is being made, to total installed wattage. For commercial applications such as stores, the use factor is generally 1.0.

The **special allowance factor** is the ratio of the lighting fixtures' power consumption, including lamps and ballast, to the nominal power consumption of the lamps. For incandescent lights, this factor is 1. For fluorescent lights, it accounts for power consumed by the ballast as well as the ballast's effect on lamp power consumption. The special allowance factor can be less than 1 for electronic ballasts that lower electricity consumption below the lamp's rated power consumption. Use manufacturers' values for system (lamps + ballast) power, when available.

For high-intensity-discharge lamps (e.g. metal halide, mercury vapor, high- and low-pressure sodium vapor lamps), the actual lighting system power consumption should be available from the manufacturer of the fixture or ballast. Ballasts available for metal halide and high pressure sodium vapor lamps may have special allowance factors from about 1.3 (for low-wattage lamps) down to 1.1 (for high-wattage lamps).

An alternative procedure is to estimate the lighting heat gain on a per square foot basis. Such an approach may be required when final lighting plans are not available. Table 2 shows the maximum lighting power density (LPD) (lighting heat gain per square foot) allowed by ASHRAE Standard 90.1-2007 for a range of space types.

In addition to determining the lighting heat gain, the fraction of lighting heat gain that enters the conditioned space may need to be distinguished from the fraction that enters an unconditioned space; of the former category, the distribution between radiative and convective heat gain must be established.

Fisher and Chantrasrisalai (2006) experimentally studied 12 luminaire types and recommended five different categories of luminaires,

as shown in Table 3. The table provides a range of design data for the conditioned space fraction, short-wave radiative fraction, and long-wave radiative fraction under typical operating conditions: airflow rate of 1 cfm/ft², supply air temperature between 59 and 62°F, and room air temperature between 72 and 75°F. The recommended fractions in Table 3 are based on lighting heat input rates range of 0.9 to 2.6 W/ft². For higher design power input, the lower bounds of the space and short-wave fractions should be used; for design power input below this range, the upper bounds of the space and short-wave fractions should be used. The **space fraction** in the table is the fraction of lighting heat gain that goes to the room; the fraction going to the plenum can be computed as 1 – the space fraction. The **radiative fraction** is the radiative part of the lighting heat gain that goes to the room. The convective fraction of the lighting heat gain that goes to the room is 1 – the radiative fraction. Using values in the middle of the range yields sufficiently accurate results. However, values that better suit a specific situation may be determined according to the notes for Table 3.

Table 3's data are applicable for both ducted and nonducted returns. However, application of the data, particularly the ceiling plenum fraction, may vary for different return configurations. For instance, for a room with a ducted return, although a portion of the lighting energy initially dissipated to the ceiling plenum is quantitatively equal to the plenum fraction, a large portion of this energy would likely end up as the conditioned space cooling load and a small portion would end up as the cooling load to the return air.

If the space airflow rate is different from the typical condition (i.e., about 1 cfm/ft²), Figure 3 can be used to estimate the lighting heat gain parameters. Design data shown in Figure 3 are only applicable for the recessed fluorescent luminaire without lens.

Although design data presented in Table 3 and Figure 3 can be used for a vented luminaire with side-slot returns, they are likely not applicable for a vented luminaire with lamp compartment returns, because in the latter case, all heat convected in the vented luminaire is likely to go directly to the ceiling plenum, resulting in zero convective fraction and a much lower space fraction. Therefore, the design data should only be used for a configuration where conditioned air is returned through the ceiling grille or luminaire side slots.

Table 2 Lighting Power Densities Using Space-by-Space Method

Common Space Types*	LPD, W/ft ²	Building-Specific Space Types	LPD, W/ft ²
Office—enclosed	1.1	Gymnasium/exercise center	
Office—open plan	1.1	Playing Area	1.4
Conference/meeting/multipurpose	1.3	Exercise Area	0.9
Classroom/lecture/training	1.4	Courthouse/police station/penitentiary	
For penitentiary	1.3	Courtroom	1.9
Lobby	1.3	Confinement cells	0.9
For hotel	1.1	Judges' chambers	1.3
For performing arts theater	3.3	Fire Stations	
For motion picture theater	1.1	Engine room	0.8
Audience/seating Area	0.9	Sleeping quarters	0.3
For gymnasium	0.4	Post office—sorting area	1.2
For exercise center	0.3	Convention center—exhibit space	1.3
For convention center	0.7	Library	
For penitentiary	0.7	Card file and cataloging	1.1
For religious buildings	1.7	Stacks	1.7
For sports arena	0.4	Reading area	1.2
For performing arts theater	2.6	Hospital	
For motion picture theater	1.2	Emergency	2.7
For transportation	0.5	Recovery	0.8
Atrium—first three floors	0.6	Nurses' station	1.0
Atrium—each additional floor	0.2	Exam/treatment	1.5
Lounge/recreation	1.2	Pharmacy	1.2
For hospital	0.8	Patient room	0.7
Dining Area	0.9	Operating room	2.2
For penitentiary	1.3	Nursery	0.6
For hotel	1.3	Medical supply	1.4
For motel	1.2	Physical therapy	0.9
For bar lounge/leisure dining	1.4	Radiology	0.4
For family dining	2.1	Laundry—washing	0.6
Food preparation	1.2	Automotive—service/repair	0.7
Laboratory	1.4	Manufacturing	
Restrooms	0.9	Low bay (<25 ft floor to ceiling height)	1.2
Dressing/locker/fitting room	0.6	High bay (≥25 ft/7.6 m floor to ceiling height)	1.7
Corridor/transition	0.5	Detailed manufacturing	2.1
For hospital	1.0	Equipment room	1.2
For manufacturing facility	0.5	Control room	0.5
Stairs—active	0.6	Hotel/motel guest rooms	1.1
Active storage	0.8	Dormitory—living quarters	1.1
For hospital	0.9	Museum	
Inactive storage	0.3	General exhibition	1.0
For museum	0.8	Restoration	1.7
Electrical/mechanical	1.5	Bank/office—banking activity area	1.5
Workshop	1.9	Religious buildings	
Sales area [for accent lighting, see Section 9.6.2(B) of ASHRAE Standard 90.1]	1.7	Worship pulpit, choir	2.4
		Fellowship hall	0.9
		Retail	
		Sales area for accent lighting, see Section 9.6.3(C) of ASHRAE Standard 90.1]	1.7
		Mall concourse	1.7
		Sports arena	
		Ring sports area	2.7
		Court sports area	2.3
		Indoor playing field area	1.4
		Warehouse	
		Fine material storage	1.4
		Medium/bulky material storage	0.9
		Parking garage—garage area	0.2
		Transportation	
		Airport—concourse	0.6
		Air/train/bus—baggage area	1.0
		Terminal—ticket counter	1.5

Source: ASHRAE Standard 90.1-2007.

*In cases where both a common space type and a building-specific type are listed, the building-specific space type applies.

For other luminaire types, it may be necessary to estimate the heat gain for each component as a fraction of the total lighting heat gain by using judgment to estimate heat-to-space and heat-to-return percentages.

Because of the directional nature of downlight luminaires, a large portion of the short-wave radiation typically falls on the floor. When converting heat gains to cooling loads in the RTS method, the solar radiant time factors (RTF) may be more appropriate than non-solar RTF. (Solar RTF are calculated assuming most solar radiation is intercepted by the floor; nonsolar RTF assume uniform distribution by area over all interior surfaces.) This effect may be significant for rooms where lighting heat gain is high and for which solar RTF are significantly different from nonsolar RTF.

ELECTRIC MOTORS

Instantaneous sensible heat gain from equipment operated by electric motors in a conditioned space is calculated as

$$q_{em} = 2545(P/E_M)F_{UM}F_{LM} \tag{2}$$

where

- q_{em} = heat equivalent of equipment operation, Btu/h
- P = motor power rating, hp
- E_M = motor efficiency, decimal fraction <1.0
- F_{UM} = motor use factor, 1.0 or decimal fraction <1.0
- F_{LM} = motor load factor, 1.0 or decimal fraction <1.0
- 2545 = conversion factor, Btu/h·hp

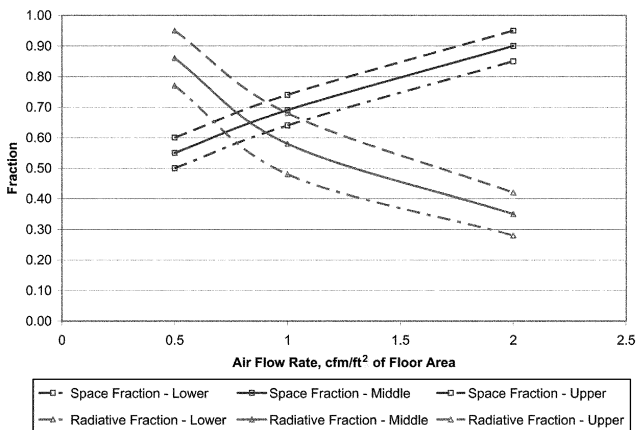

Fig. 3 Lighting Heat Gain Parameters for Recessed Fluorescent Luminaire Without Lens
(Fisher and Chantrasrisalai 2006)

Table 3 Lighting Heat Gain Parameters for Typical Operating Conditions

Luminaire Category	Space Fraction	Radiative Fraction	Notes
Recessed fluorescent luminaire without lens	0.64 to 0.74	0.48 to 0.68	<ul style="list-style-type: none"> • Use middle values in most situations • May use higher space fraction, and lower radiative fraction for luminaire with side-slot returns • May use lower values of both fractions for direct/indirect luminaire • May use higher values of both fractions for ducted returns
Recessed fluorescent luminaire with lens	0.40 to 0.50	0.61 to 0.73	<ul style="list-style-type: none"> • May adjust values in the same way as for recessed fluorescent luminaire without lens
Downlight compact fluorescent luminaire	0.12 to 0.24	0.95 to 1.0	<ul style="list-style-type: none"> • Use middle or high values if detailed features are unknown • Use low value for space fraction and high value for radiative fraction if there are large holes in luminaire's reflector
Downlight incandescent luminaire	0.70 to 0.80	0.95 to 1.0	<ul style="list-style-type: none"> • Use middle values if lamp type is unknown • Use low value for space fraction if standard lamp (i.e. A-lamp) is used • Use high value for space fraction if reflector lamp (i.e. BR-lamp) is used
Non-in-ceiling fluorescent luminaire	1.0	0.5 to 0.57	<ul style="list-style-type: none"> • Use lower value for radiative fraction for surface-mounted luminaire • Use higher value for radiative fraction for pendant luminaire

Source: Fisher and Chantrasrisalai (2006).

The motor use factor may be applied when motor use is known to be intermittent, with significant nonuse during all hours of operation (e.g., overhead door operator). For conventional applications, its value is 1.0.

The motor load factor is the fraction of the rated load delivered under the conditions of the cooling load estimate. In Equation (2), it is assumed that both the motor and driven equipment are in the conditioned space. If the motor is outside the space or airstream,

$$q_{em} = 2545PF_{UM}F_{LM} \tag{3}$$

When the motor is inside the conditioned space or airstream but the driven machine is outside,

$$q_{em} = 2545P\left(\frac{1.0 - E_M}{E_M}\right)F_{UM}F_{LM} \tag{4}$$

Equation (4) also applies to a fan or pump in the conditioned space that exhausts air or pumps fluid outside that space.

Table 4 gives minimum efficiencies and related data representative of typical electric motors from ASHRAE Standard 90.1-2007. If electric motor load is an appreciable portion of cooling load, the motor efficiency should be obtained from the manufacturer. Also, depending on design, maximum efficiency might occur anywhere between 75 to 110% of full load; if under- or overloaded, efficiency could vary from the manufacturer's listing.

Overloading or Underloading

Heat output of a motor is generally proportional to motor load, within rated overload limits. Because of typically high no-load motor current, fixed losses, and other reasons, F_{LM} is generally assumed to be unity, and no adjustment should be made for underloading or overloading unless the situation is fixed and can be accurately established, and reduced-load efficiency data can be obtained from the motor manufacturer.

Radiation and Convection

Unless the manufacturer's technical literature indicates otherwise, motor heat gain normally should be equally divided between radiant and convective components for the subsequent cooling load calculations.

APPLIANCES

A cooling load estimate should take into account heat gain from all appliances (electrical, gas, or steam). Because of the variety of appliances, applications, schedules, use, and installations, estimates can be very subjective. Often, the only information available about

Table 4 Minimum Nominal Efficiency for General Purpose Design A and Design B Motors*

		Minimum Nominal Full-Load Efficiency, %					
		Open Motors			Enclosed Motors		
Number of Poles ⇒		2	4	6	2	4	6
	Synchronous Speed (RPM) ⇒	3600	1800	1200	3600	1800	1200
Motor Horsepower							
1	—	82.5	80.0	75.5	82.5	80.0	
1.5	82.5	84.0	84.0	82.5	84.0	85.5	
2	84.0	84.0	85.5	84.0	84.0	86.5	
3	84.0	86.5	86.5	85.5	87.5	87.5	
5	85.5	87.5	87.5	87.5	87.5	87.5	
7.5	87.5	88.5	88.5	88.5	89.5	89.5	
10	88.5	89.5	90.2	89.5	89.5	89.5	
15	89.5	91.0	90.2	90.2	91.0	90.2	
20	90.2	91.0	91.0	90.2	91.0	90.2	
25	91.0	91.7	91.7	91.0	92.4	91.7	
30	91.0	92.4	92.4	91.0	92.4	91.7	
40	91.7	93.0	93.0	91.7	93.0	93.0	
50	92.4	93.0	93.0	92.4	93.0	93.0	
60	93.0	93.6	93.6	93.0	93.6	93.6	
75	93.0	94.1	93.6	93.0	94.1	93.6	
100	93.0	94.1	94.1	93.6	94.5	94.1	
125	93.6	94.5	94.1	94.5	94.5	94.1	
150	93.6	95.0	94.5	94.5	95.0	95.0	
200	94.5	95.0	94.5	95.0	95.0	95.0	

Source: ASHRAE Standard 90.1-2007.

*Nominal efficiencies established in accordance with NEMA Standard MG1. Designs A and B are National Electric Manufacturers Association (NEMA) design class designations for fixed-frequency small and medium AC squirrel-cage induction motors.

heat gain from equipment is that on its nameplate, which can overestimate actual heat gain for many types of appliances, as discussed in the section on Office Equipment.

Cooking Appliances

These appliances include common heat-producing cooking equipment found in conditioned commercial kitchens. Marn (1962) concluded that appliance surfaces contributed most of the heat to commercial kitchens and that when appliances were installed under an effective hood, the cooling load was independent of the fuel or energy used for similar equipment performing the same operations.

Gordon et al. (1994) and Smith et al. (1995) found that gas appliances may exhibit slightly higher heat gains than their electric counterparts under wall-canopy hoods operated at typical ventilation rates. This is because heat contained in combustion products exhausted from a gas appliance may increase the temperatures of the appliance and surrounding surfaces, as well as the hood above the appliance, more so than the heat produced by its electric counterpart. These higher-temperature surfaces radiate heat to the kitchen, adding moderately to the radiant gain directly associated with the appliance cooking surface.

Marn (1962) confirmed that, where appliances are installed under an effective hood, only radiant gain adds to the cooling load; convective and latent heat from cooking and combustion products are exhausted and do not enter the kitchen. Gordon et al. (1994) and Smith et al. (1995) substantiated these findings. Chapter 31 of the 2007 ASHRAE Handbook—HVAC Applications has more information on kitchen ventilation.

Sensible Heat Gain for Hooded Cooking Appliances. To establish a heat gain value, nameplate energy input ratings may be used with appropriate usage and radiation factors. Where specific rating data are not available (nameplate missing, equipment not yet purchased, etc.), representative heat gains listed in Tables 5A to E (Swierczyna et al. 2008, 2009) for a wide variety of commonly encountered equipment items. In estimating appliance load, probabilities of simultaneous use and operation for different appliances located in the same space must be considered.

Radiant heat gain from hooded cooking equipment can range from 15 to 45% of the actual appliance energy consumption (Gordon et al. 1994; Smith et al. 1995; Swierczyna et al. 2008; Talbert et al. 1973). This ratio of heat gain to appliance energy consumption may be expressed as a radiation factor, and it is a function of both appliance type and fuel source. The radiation factor F_R is applied to the average rate of appliance energy consumption, determined by applying usage factor F_U to the nameplate or rated energy input. Marn (1962) found that radiant heat temperature rise can be substantially reduced by shielding the fronts of cooking appliances. Although this approach may not always be practical in a commercial kitchen, radiant gains can also be reduced by adding side panels or partial enclosures that are integrated with the exhaust hood.

Heat Gain from Meals. For each meal served, approximately 50 Btu/h of heat, of which 75% is sensible and 25% is latent, is transferred to the dining space.

Heat Gain for Generic Appliances. The average rate of appliance energy consumption can be estimated from the nameplate or rated energy input q_{input} by applying a duty cycle or usage factor F_U . Thus, sensible heat gain q_s for generic electric, steam, and gas appliances installed under a hood can be estimated using one of the following equations:

$$q_s = q_{input} F_U F_R \tag{5}$$

or

$$q_s = q_{input} F_L \tag{6}$$

where F_L is the ratio of sensible heat gain to the manufacturer’s rated energy input. However, recent ASHRAE research (Swierczyna et al. 2008, 2009) showed the design value for heat gain from a hooded appliance at idle (ready-to-cook) conditions based on its energy consumption rate is, at best, a rough estimate. When appliance heat gain measurements during idle conditions were regressed against energy consumption rates for gas and electric appliances, the appliances’ emissivity, insulation, and surface cooling (e.g., through ventilation rates) scattered the data points widely, with large deviations from the average values. Because large errors could occur in the heat load calculation for specific appliance lines by using a general radiation factor, heat gain values in Table 5 should be applied in the HVAC design.

Table 5 lists usage factors, radiation factors, and load factors based on appliance energy consumption rate for typical electrical, steam, and gas appliances under standby or idle conditions, hooded and unhooded.

Recirculating Systems. Cooking appliances ventilated by recirculating systems or “ductless” hoods should be treated as unhooded appliances when estimating heat gain. In other words, all energy consumed by the appliance and all moisture produced by cooking is introduced to the kitchen as a sensible or latent cooling load.

Recommended Heat Gain Values. Table 5 lists recommended rates of heat gain from typical commercial cooking appliances. Data in the “hooded” columns assume installation under a properly designed exhaust hood connected to a mechanical fan exhaust system operating at an exhaust rate for complete capture and containment of the thermal and effluent plume. Improperly operating hood systems load the space with a significant convective component of the heat gain.

Table 5A Recommended Rates of Radiant and Convective Heat Gain from Unhooded Electric Appliances During Idle (Ready-to-Cook) Conditions

Appliance	Energy Rate, Btu/h		Rate of Heat Gain, Btu/h				Usage Factor F_u	Radiation Factor F_r
	Rated	Standby	Sensible Radiant	Sensible Convective	Latent	Total		
Cabinet: hot serving (large), insulated*	6,800	1,200	400	800	0	1,200	0.18	0.33
Cabinet: hot serving (large), uninsulated	6,800	3,500	700	2,800	0	3,500	0.51	0.2
Cabinet: proofing (large)*	17,400	1,400	1,200	0	200	1,400	0.08	0.86
Cabinet: proofing (small-15 shelf)	14,300	3,900	0	900	3,000	3,900	0.27	0
Coffee brewing urn	13,000	1,200	200	300	700	1,200	0.09	0.17
Drawer warmers, 2-drawer (moist holding)*	4,100	500	0	0	200	200	0.12	0
Egg cooker	10,900	700	300	400	0	700	0.06	0.43
Espresso machine*	8,200	1,200	400	800	0	1,200	0.15	0.33
Food warmer: steam table (2-well-type)	5,100	3,500	300	600	2,600	3,500	0.69	0.09
Freezer (small)	2,700	1,100	500	600	0	1,100	0.41	0.45
Hot dog roller*	3,400	2,400	900	1,500	0	2,400	0.71	0.38
Hot plate: single burner, high speed	3,800	3,000	900	2,100	0	3,000	0.79	0.3
Hot-food case (dry holding)*	31,100	2,500	900	1,600	0	2,500	0.08	0.36
Hot-food case (moist holding)*	31,100	3,300	900	1,800	600	3,300	0.11	0.27
Microwave oven: commercial (heavy duty)	10,900	0	0	0	0	0	0	0
Oven: countertop conveyORIZED bake/finishing*	20,500	12,600	2,200	10,400	0	12,600	0.61	0.17
Panini*	5,800	3,200	1,200	2,000	0	3,200	0.55	0.38
Popcorn popper*	2,000	200	100	100	0	200	0.1	0.5
Rapid-cook oven (quartz-halogen)*	41,000	0	0	0	0	0	0	0
Rapid-cook oven (microwave/convection)*	24,900	4,100	1,000	3,100	0	1,000	0.16	0.24
Reach-in refrigerator*	4,800	1,200	300	900	0	1,200	0.25	0.25
Refrigerated prep table*	2,000	900	600	300	0	900	0.45	0.67
Steamer (bun)	5,100	700	600	100	0	700	0.14	0.86
Toaster: 4-slice pop up (large): cooking	6,100	3,000	200	1,400	1,000	2,600	0.49	0.07
Toaster: contact (vertical)	11,300	5,300	2,700	2,600	0	5,300	0.47	0.51
Toaster: conveyor (large)	32,800	10,300	3,000	7,300	0	10,300	0.31	0.29
Toaster: small conveyor	5,800	3,700	400	3,300	0	3,700	0.64	0.11
Waffle iron	3,100	1,200	800	400	0	1,200	0.39	0.67

Source: Swierczyna et al. (2008, 2009).

Hospital and Laboratory Equipment

Hospital and laboratory equipment items are major sources of sensible and latent heat gains in conditioned spaces. Care is needed in evaluating the probability and duration of simultaneous usage when many components are concentrated in one area, such as a laboratory, an operating room, etc. Commonly, heat gain from equipment in a laboratory ranges from 15 to 70 Btu/h·ft² or, in laboratories with outdoor exposure, as much as four times the heat gain from all other sources combined.

Medical Equipment. It is more difficult to provide generalized heat gain recommendations for medical equipment than for general office equipment because medical equipment is much more varied in type and in application. Some heat gain testing has been done, but the equipment included represents only a small sample of the type of equipment that may be encountered.

Data presented for medical equipment in Table 6 are relevant for portable and bench-top equipment. Medical equipment is very specific and can vary greatly from application to application. The data are presented to provide guidance in only the most general sense. For large equipment, such as MRI, heat gain must be obtained from the manufacturer.

Laboratory Equipment. Equipment in laboratories is similar to medical equipment in that it varies significantly from space to space. Chapter 14 of the 2007 *ASHRAE Handbook—HVAC Applications* discusses heat gain from equipment, which may range from 5 to 25 W/ft² in highly automated laboratories. Table 7 lists some values for laboratory equipment, but, with medical equipment, it is for general guidance only. Wilkins and Cook (1999) also examined laboratory equipment heat gains.

Office Equipment

Computers, printers, copiers, etc., can generate very significant heat gains, sometimes greater than all other gains combined. ASHRAE research project RP-822 developed a method to measure the actual heat gain from equipment in buildings and the radiant/convective percentages (Hosni et al. 1998; Jones et al. 1998). This methodology was then incorporated into ASHRAE research project RP-1055 and applied to a wide range of equipment (Hosni et al. 1999) as a follow-up to independent research by Wilkins and McGaffin (1994) and Wilkins et al. (1991). Komor (1997) found similar results. Analysis of measured data showed that results for office equipment could be generalized, but results from laboratory and hospital equipment proved too diverse. The following general guidelines for office equipment are a result of these studies.

Nameplate Versus Measured Energy Use. Nameplate data rarely reflect the actual power consumption of office equipment. Actual power consumption is assumed to equal total (radiant plus convective) heat gain, but its ratio to the nameplate value varies widely. ASHRAE research project RP-1055 (Hosni et al. 1999) found that, for general office equipment with nameplate power consumption of less than 1000 W, the actual ratio of total heat gain to nameplate ranged from 25% to 50%, but when all tested equipment is considered, the range is broader. Generally, if the nameplate value is the only information known and no actual heat gain data are available for similar equipment, it is conservative to use 50% of nameplate as heat gain and more nearly correct if 25% of nameplate is used. Much better results can be obtained, however, by considering heat gain to be predictable based on the type of equipment. However, if the device has a mainly resistive internal electric load (e.g.,

Table 5B Recommended Rates of Radiant Heat Gain from Hooded Electric Appliances During Idle (Ready-to-Cook) Conditions

Appliance	Energy Rate, Btu/h		Rate of Heat Gain, Btu/h		
	Rated	Standby	Sensible Radiant	Usage Factor F_u	Radiation Factor F_r
Broiler: underfired 3 ft	36,900	30,900	10,800	0.84	0.35
Cheesemelter*	12,300	11,900	4,600	0.97	0.39
Fryer: kettle	99,000	1,800	500	0.02	0.28
Fryer: open deep-fat, 1-vat	47,800	2,800	1,000	0.06	0.36
Fryer: pressure	46,100	2,700	500	0.06	0.19
Griddle: double sided 3 ft (clamshell down)*	72,400	6,900	1,400	0.1	0.2
Griddle: double sided 3 ft (clamshell up)*	72,400	11,500	3,600	0.16	0.31
Griddle: flat 3 ft	58,400	11,500	4,500	0.2	0.39
Griddle-small 3 ft*	30,700	6,100	2,700	0.2	0.44
Induction cooktop*	71,700	0	0	0	0
Induction wok*	11,900	0	0	0	0
Oven: combi: combi-mode*	56,000	5,500	800	0.1	0.15
Oven: combi: convection mode	56,000	5,500	1,400	0.1	0.25
Oven: convection full-size	41,300	6,700	1,500	0.16	0.22
Oven: convection half-size*	18,800	3,700	500	0.2	0.14
Pasta cooker*	75,100	8,500	0	0.11	0
Range top: top off/oven on*	16,600	4,000	1,000	0.24	0.25
Range top: 3 elements on/oven off	51,200	15,400	6,300	0.3	0.41
Range top: 6 elements on/oven off	51,200	33,200	13,900	0.65	0.42
Range top: 6 elements on/oven on	67,800	36,400	14,500	0.54	0.4
Range: hot-top	54,000	51,300	11,800	0.95	0.23
Rotisserie*	37,900	13,800	4,500	0.36	0.33
Salamander*	23,900	23,300	7,000	0.97	0.3
Steam kettle: large (60 gal) simmer lid down*	110,600	2,600	100	0.02	0.04
Steam kettle: small (40 gal) simmer lid down*	73,700	1,800	300	0.02	0.17
Steamer: compartment: atmospheric*	33,400	15,300	200	0.46	0.01
Tilting skillet/braising pan	32,900	5,300	0	0.16	0

Source: Swierczyna et al. (2008, 2009).

a space heater), the nameplate rating may be a good estimate of its peak energy dissipation.

Computers. Based on tests by Hosni et al. (1999) and Wilkins and McGaffin (1994), nameplate values on computers should be ignored when performing cooling load calculations. Table 8 presents typical heat gain values for computers with varying degrees of safety factor.

Monitors. Based on monitors tested by Hosni et al. (1999), heat gain for cathode ray tube (CRT) monitors correlates approximately with screen size as

$$q_{mon} = 5S - 20 \quad (7)$$

where

q_{mon} = sensible heat gain from monitor, W
 S = nominal screen size, in.

Table 8 shows typical values.

Flat-panel monitors have replaced CRT monitors in many workplaces. Power consumption, and thus heat gain, for flat-panel displays are significantly lower than for CRTs. Consult manufacturers' literature for average power consumption data for use in heat gain calculations.

Laser Printers. Hosni et al. (1999) found that power consumption, and therefore the heat gain, of laser printers depended largely on the level of throughput for which the printer was designed. Smaller printers tend to be used more intermittently, and larger printers may run continuously for longer periods.

Table 9 presents data on laser printers. These data can be applied by taking the value for continuous operation and then applying an appropriate diversity factor. This would likely be most appropriate for larger open office areas. Another approach, which may be appropriate for a single room or small area, is to take the value that most closely matches the expected operation of the printer with no diversity.

Copiers. Hosni et al. (1999) also tested five photocopy machines, including desktop and office (freestanding high-volume copiers) models. Larger machines used in production environments were not addressed. Table 9 summarizes the results. Desktop copiers rarely operate continuously, but office copiers frequently operate continuously for periods of an hour or more. Large, high-volume photocopiers often include provisions for exhausting air outdoors; if so equipped, the direct-to-space or system makeup air heat gain needs to be included in the load calculation. Also, when the air is dry, humidifiers are often operated near copiers to limit static electricity; if this occurs during cooling mode, their load on HVAC systems should be considered.

Miscellaneous Office Equipment. Table 10 presents data on miscellaneous office equipment such as vending machines and mailing equipment.

Diversity. The ratio of measured peak electrical load at equipment panels to the sum of the maximum electrical load of each individual item of equipment is the usage diversity. A small, one- or two-person office containing equipment listed in Tables 8 to 10 usually contributes heat gain to the space at the sum of the appropriate listed values. Progressively larger areas with many equipment items always experience some degree of usage diversity resulting from whatever percentage of such equipment is not in operation at any given time.

Wilkins and McGaffin (1994) measured diversity in 23 areas within five different buildings totaling over 275,000 ft². Diversity was found to range between 37 and 78%, with the average (normalized based on area) being 46%. Figure 4 illustrates the relationship between nameplate, sum of peaks, and actual electrical load with diversity accounted for, based on the average of the total area tested. Data on actual diversity can be used as a guide, but diversity varies

Table 5C Recommended Rates of Radiant Heat Gain from Hooded Gas Appliances During Idle (Ready-to-Cook) Conditions

Appliance	Energy Rate, Btu/h		Rate of Heat Gain, Btu/h		
	Rated	Standby	Sensible Radiant	Usage Factor F_u	Radiation Factor F_r
Broiler: batch*	95,000	69,200	8,100	0.73	0.12
Broiler: chain (conveyor)	132,000	96,700	13,200	0.73	0.14
Broiler: overfired (upright)*	100,000	87,900	2,500	0.88	0.03
Broiler: underfired 3 ft	96,000	73,900	9,000	0.77	0.12
Fryer: doughnut	44,000	12,400	2,900	0.28	0.23
Fryer: open deep-fat, 1 vat	80,000	4,700	1,100	0.06	0.23
Fryer: pressure	80,000	9,000	800	0.11	0.09
Griddle: double sided 3 ft (clamshell down)*	108,200	8,000	1,800	0.07	0.23
Griddle: double sided 3 ft (clamshell up)*	108,200	14,700	4,900	0.14	0.33
Griddle: flat 3 ft	90,000	20,400	3,700	0.23	0.18
Oven: combi: combi-mode*	75,700	6,000	400	0.08	0.07
Oven: combi: convection mode	75,700	5,800	1,000	0.08	0.17
Oven: convection full-size	44,000	11,900	1,000	0.27	0.08
Oven: conveyor (pizza)	170,000	68,300	7,800	0.4	0.11
Oven: deck	105,000	20,500	3,500	0.2	0.17
Oven: rack mini-rotating*	56,300	4,500	1,100	0.08	0.24
Pasta cooker*	80,000	23,700	0	0.3	0
Range top: top off/oven on*	25,000	7,400	2,000	0.3	0.27
Range top: 3 burners on/oven off	120,000	60,100	7,100	0.5	0.12
Range top: 6 burners on/oven off	120,000	120,800	11,500	1.01	0.1
Range top: 6 burners on/oven on	145,000	122,900	13,600	0.85	0.11
Range: wok*	99,000	87,400	5,200	0.88	0.06
Rethermalizer*	90,000	23,300	11,500	0.26	0.49
Rice cooker*	35,000	500	300	0.01	0.6
Salamander*	35,000	33,300	5,300	0.95	0.16
Steam kettle: large (60 gal) simmer lid down*	145,000	5,400	0	0.04	0
Steam kettle: small (10 gal) simmer lid down*	52,000	3,300	300	0.06	0.09
Steam kettle: small (40 gal) simmer lid down	100,000	4,300	0	0.04	0
Steamer: compartment: atmospheric *	26,000	8,300	0	0.32	0
Tilting skillet/braising pan	104,000	10,400	400	0.1	0.04

Source: Swierczyna et al. (2008, 2009).

Table 5D Recommended Rates of Radiant Heat Gain from Hooded Solid Fuel Appliances During Idle (Ready-to-Cook) Conditions

Appliance	Energy Rate, Btu/h	Rate of Heat Gain, Btu/h		Usage Factor F_u	Radiation Factor F_r
	Rated	Standby	Sensible		
Broiler: solid fuel: charcoal	40 lb	42,000	6200	N/A	0.15
Broiler: solid fuel: wood (mesquite)*	40 lb	49,600	7000	N/A	0.14

Source: Swierczyna et al. (2008, 2009).

significantly with occupancy. The proper diversity factor for an office of mail-order catalog telephone operators is different from that for an office of sales representatives who travel regularly.

ASHRAE research project RP-1093 derived diversity profiles for use in energy calculations (Abushakra et al. 2004; Claridge et al. 2004). Those profiles were derived from available measured data sets for a variety of office buildings, and indicated a range of peak weekday diversity factors for lighting ranging from 70 to 85% and for receptacles (appliance load) between 42 and 89%.

Heat Gain per Unit Area. Wilkins and Hosni (2000) and Wilkins and McGaffin (1994) summarized research on a heat gain per unit area basis. Diversity testing showed that the actual heat gain per unit area, or load factor, ranged from 0.44 to 1.08 W/ft², with an average

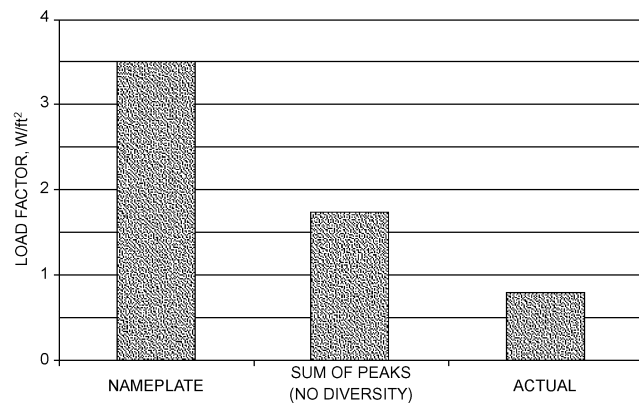

Fig. 4 Office Equipment Load Factor Comparison
(Wilkins and McGaffin 1994)

(normalized based on area) of 0.81 W/ft². Spaces tested were fully occupied and highly automated, comprising 21 unique areas in five buildings, with a computer and monitor at every workstation. Table 11 presents a range of load factors with a subjective description of the type of space to which they would apply. Table 12 presents more specific data that can be used to better quantify the amount of equipment in a space and expected load factor. The medium load density is likely to be appropriate for most standard office spaces. Medium/heavy or heavy load densities may be encountered but can

Table 5E Recommended Rates of Radiant and Convective Heat Gain from Warewashing Equipment During Idle (Standby) or Washing Conditions

Appliance	Rate of Heat Gain, Btu/h								
	Energy Rate, Btu/h		Unhooded				Hooded		
	Rated	Standby/ Washing	Sensible Radiant	Sensible Convective	Latent	Total	Sensible Radiant	Usage Factor F_u	Radiation Factor F_r
Dishwasher (conveyor type, chemical sanitizing)	46,800	5700/43,600	0	4450	13490	17940	0	0.36	0
Dishwasher (conveyor type, hot-water sanitizing) standby	46,800	5700/N/A	0	4750	16970	21720	0	N/A	0
Dishwasher (door-type, chemical sanitizing) washing	18,400	1200/13,300	0	1980	2790	4770	0	0.26	0
Dishwasher (door-type, hot-water sanitizing) washing	18,400	1200/13,300	0	1980	2790	4770	0	0.26	0
Dishwasher* (under-counter type, chemical sanitizing) standby	26,600	1200/18,700	0	2280	4170	6450	0	0.35	0.00
Dishwasher* (under-counter type, hot-water sanitizing) standby	26,600	1700/19,700	800	1040	3010	4850	800	0.27	0.34
Booster heater*	130,000	0	500	0	0	0	500	0	N/A

Note: Heat load values are prorated for 30% washing and 70% standby. Source: Swierczyna et al. (2008, 2009).

Table 6 Recommended Heat Gain from Typical Medical Equipment

Equipment	Nameplate, W	Peak, W	Average, W
Anesthesia system	250	177	166
Blanket warmer	500	504	221
Blood pressure meter	180	33	29
Blood warmer	360	204	114
ECG/RESP	1440	54	50
Electrosurgery	1000	147	109
Endoscope	1688	605	596
Harmonical scalpel	230	60	59
Hysteroscopic pump	180	35	34
Laser sonics	1200	256	229
Optical microscope	330	65	63
Pulse oximeter	72	21	20
Stress treadmill	N/A	198	173
Ultrasound system	1800	1063	1050
Vacuum suction	621	337	302
X-ray system	968		82
	1725	534	480
	2070		18

Source: Hosni et al. (1999).

be considered extremely conservative estimates even for densely populated and highly automated spaces.

Radiant Convective Split. ASHRAE research project RP-1482 (Hosni and Beck 2008) is examining the radiant/convective split for common office equipment; the most important differentiating feature is whether the equipment had a cooling fan. Footnotes in Tables 8 and 9 summarizes those results.

INFILTRATION AND MOISTURE MIGRATION HEAT GAINS

Two other load components contribute to space cooling load directly without time delay from building mass: (1) infiltration, and (2) moisture migration through the building envelope.

INFILTRATION

Principles of estimating infiltration in buildings, with emphasis on the heating season, are discussed in Chapter 16. When economically feasible, somewhat more outdoor air should be introduced to a building than the total of that exhausted, to create a slight overall positive pressure in the building relative to the outdoors. Under

Table 7 Recommended Heat Gain from Typical Laboratory Equipment

Equipment	Nameplate, W	Peak, W	Average, W
Analytical balance	7	7	7
Centrifuge	138	89	87
	288	136	132
	5500	1176	730
Electrochemical analyzer	50	45	44
	100	85	84
Flame photometer	180	107	105
Fluorescent microscope	150	144	143
	200	205	178
Function generator	58	29	29
Incubator	515	461	451
	600	479	264
	3125	1335	1222
Orbital shaker	100	16	16
Oscilloscope	72	38	38
	345	99	97
Rotary evaporator	75	74	73
	94	29	28
Spectronics	36	31	31
Spectrophotometer	575	106	104
	200	122	121
	N/A	127	125
Spectro fluorometer	340	405	395
Thermocycler	1840	965	641
	N/A	233	198
Tissue culture	475	132	46
	2346	1178	1146

Source: Hosni et al. (1999).

these conditions, air usually exfiltrates, rather than infiltrates, through the building envelope and thus effectively eliminates infiltration sensible and latent heat gains. However, there is concern, especially in some climates, that water may condense within the building envelope; actively managing space air pressures to reduce this condensation problem, as well as infiltration, may be needed.

When positive air pressure is assumed, most designers do not include infiltration in cooling load calculations for commercial buildings. However, including some infiltration for spaces such entry areas or loading docks may be appropriate, especially when those spaces are on the windward side of buildings. But the downward stack effect, as occurs when indoor air is denser than the outdoor,

Table 8 Recommended Heat Gain from Typical Computer Equipment

Equipment	Description	Nameplate Power Consumption, W	Average Power Consumption, W
Desktop computer ^a	Manufacturer A (model A); 2.8 GHz processor, 1 GB RAM	480	73
	Manufacturer A (model B); 2.6 GHz processor, 2 GB RAM	480	49
	Manufacturer B (model A); 3.0 GHz processor, 2 GB RAM	690	77
	Manufacturer B (model B); 3.0 GHz processor, 2 GB RAM	690	48
	Manufacturer A (model C); 2.3 GHz processor, 3 GB RAM	1200	97
Laptop computer ^b	Manufacturer 1; 2.0 GHz processor, 2 GB RAM, 17 in. screen	130	36
	Manufacturer 1; 1.8 GHz processor, 1 GB RAM, 17 in. screen	90	23
	Manufacturer 1; 2.0 GHz processor, 2 GB RAM, 14 in. screen	90	31
	Manufacturer 2; 2.13 GHz processor, 1 GB RAM, 14 in. screen, tablet PC	90	29
	Manufacturer 2; 366 MHz processor, 130 MB RAM, 14 in. screen)	70	22
	Manufacturer 3; 900 MHz processor, 256 MB RAM (10.5 in. screen)	50	12
Flat-panel monitor ^c	Manufacturer X (model A); 30 in. screen	383	90
	Manufacturer X (model B); 22 in. screen	360	36
	Manufacturer Y (model A); 19 in. screen	288	28
	Manufacturer Y (model B); 17 in. screen	240	27
	Manufacturer Z (model A); 17 in. screen	240	29
	Manufacturer Z (model C); 15 in. screen	240	19

Source: Hosni and Beck (2008).

^aPower consumption for newer desktop computers in operational mode varies from 50 to 100 W, but a conservative value of about 65 W may be used. Power consumption in sleep mode is negligible. Because of cooling fan, approximately 90% of load is by convection and 10% is by radiation. Actual power consumption is about 10 to 15% of nameplate value.

^bPower consumption of laptop computers is relatively small: depending on processor speed and screen size, it varies from about 15 to 40 W. Thus, differentiating between radiative and convective parts of the cooling load is unnecessary and the entire load may be classified as convective. Otherwise, a 75/25% split between convective and radiative components may be used. Actual power consumption for laptops is about 25% of nameplate values.

^cFlat-panel monitors have replaced cathode ray tube (CRT) monitors in many workplaces, providing better resolution and being much lighter. Power consumption depends on size and resolution, and ranges from about 20 W (for 15 in. size) to 90 W (for 30 in.). The most common sizes in workplaces are 19 and 22 in., for which an average 30 W power consumption value may be used. Use 60/40% split between convective and radiative components. In idle mode, monitors have negligible power consumption. Nameplate values should not be used.

Table 9 Recommended Heat Gain from Typical Laser Printers and Copiers

Equipment	Description	Nameplate Power Consumption, W	Average Power Consumption, W
Laser printer, typical desktop, small-office type ^a	Printing speed up to 10 pages per minute	430	137
	Printing speed up to 35 pages per minute	890	74
	Printing speed up to 19 pages per minute	508	88
	Printing speed up to 17 pages per minute	508	98
	Printing speed up to 19 pages per minute	635	110
	Printing speed up to 24 page per minute	1344	130
Multifunction (copy, print, scan) ^b	Small, desktop type	600	30
	Medium, desktop type	40	15
Scanner ^b	Small, desktop type	700	135
	Large, multiuser, office type	19	16
Copy machine ^c		1750	800 (idle 260 W)
		1440	550 (idle 135 W)
		1850	1060 (idle 305 W)
Fax machine	Medium	936	90
	Small	40	20
Plotter	Manufacturer A	400	250
	Manufacturer B	456	140

Source: Hosni and Beck (2008).

^aVarious laser printers commercially available and commonly used in personal offices were tested for power consumption in print mode, which varied from 75 to 140 W, depending on model, print capacity, and speed. Average power consumption of 110 W may be used. Split between convection and radiation is approximately 70/30%.

^bSmall multifunction (copy, scan, print) systems use about 15 to 30 W; medium-sized ones use about 135 W. Power consumption in idle mode is negligible.

Nameplate values do not represent actual power consumption and should not be used.

Small, single-sheet scanners consume less than 20 W and do not contribute significantly to building cooling load.

^cPower consumption for large copy machines in large offices and copy centers ranges from about 550 to 1100 W in copy mode. Consumption in idle mode varies from about 130 to 300 W. Count idle-mode power consumption as mostly convective in cooling load calculations.

might eliminate infiltration to these entries on lower floors of tall buildings; infiltration may occur on the upper floors during cooling conditions if makeup air is not sufficient.

Infiltration also depends on wind direction and magnitude, temperature differences, construction type and quality, and occupant

use of exterior doors and operable windows. As such, it is impossible to accurately predict infiltration rates. Designers usually predict overall rates of infiltration using the number of **air changes per hour (ach)**. A common guideline for climates and buildings typical of at least the central United States is to estimate the achs for winter

Table 10 Recommended Heat Gain from Miscellaneous Office Equipment

Equipment	Maximum Input Rating, W	Recommended Rate of Heat Gain, W
Mail-processing equipment		
Folding machine	125	80
Inserting machine, 3600 to 6800 pieces/h	600 to 3300	390 to 2150
Labeling machine, 1500 to 30,000 pieces/h	600 to 6600	390 to 4300
Postage meter	230	150
Vending machines		
Cigarette	72	72
Cold food/beverage	1150 to 1920	575 to 960
Hot beverage	1,725	862
Snack	240 to 275	240 to 275
Other		
Bar code printer	440	370
Cash registers	60	48
Check processing workstation, 12 pockets	4800	2470
Coffee maker, 10 cups	1500	1050 W sens., 1540 Btu/h latent
Microfiche reader	85	85
Microfilm reader	520	520
Microfilm reader/printer	1150	1150
Microwave oven, 1 ft ³	600	400
Paper shredder	250 to 3000	200 to 2420
Water cooler, 32 qt/h	700	350

Table 11 Recommended Load Factors for Various Types of Offices

Load Density of Office	Load Factor, W/ft ²	Description
Light	0.5	Assumes 167 ft ² /workstation (6 workstations per 1000 ft ²) with computer and monitor at each plus printer and fax. Computer, monitor, and fax diversity 0.67, printer diversity 0.33.
Medium	1	Assumes 125 ft ² /workstation (8 workstations per 1000 ft ²) with computer and monitor at each plus printer and fax. Computer, monitor, and fax diversity 0.75, printer diversity 0.50.
Medium/Heavy	1.5	Assumes 100 ft ² /workstation (10 workstations per 1000 ft ²) with computer and monitor at each plus printer and fax. Computer and monitor diversity 0.75, printer and fax diversity 0.50.
Heavy	2	Assumes 83 ft ² /workstation (12 workstations per 1000 ft ²) with computer and monitor at each plus printer and fax. Computer and monitor diversity 1.0, printer and fax diversity 0.50.

Source: Wilkins and Hosni (2000).

heating conditions, and then use half that value for the cooling load calculations.

Standard Air Volumes

Because the specific volume of air varies appreciably, calculations are more accurate when made on the basis of air mass instead of volume. However, volumetric flow rates are often required for selecting coils, fans, ducts, etc.; basing volumes on measurement at standard conditions may be used for accurate results. One standard value is 0.075 lb_{da}/ft³ (13.33 ft³/lb). This density corresponds to about 60°F at saturation and 69°F dry air (at 14.696 psia). Because

Table 12 Cooling Load Estimates for Various Office Load Densities

Load Density*	Number	Each, W	Total, W	Diversity	Load, W
Light					
Computers	6	55	330	0.67	220
Monitors	6	55	330	0.67	220
Laser printer—small desk top	1	130	130	0.33	43
Fax machine	1	15	15	0.67	10
Total Area Load					493
Recommended equipment load factor = 0.5 W/ft ²					
Medium					
Computers	8	65	520	0.75	390
Monitors	8	70	560	0.75	420
Laser printer—desk	1	215	215	0.5	108
Fax machine	1	15	15	0.75	11
Total Area Load					929
Recommended equipment load factor = 1.0 W/ft ²					
Medium/Heavy					
Computers	10	65	650	1	650
Monitors	10	70	700	1	700
Laser printer—small office	1	320	320	0.5	160
Fax machine	1	30	30	0.5	15
Total Area Load					1525
Recommended equipment load factor = 1.5 W/ft ²					
Heavy					
Computers	12	75	900	1	900
Monitors	12	80	960	1	960
Laser printer-small office	1	320	320	0.5	160
Fax machine	1	30	30	0.5	15
Total Area Load					2035
Recommended equipment load factor = 2.0 W/ft ²					

Source: Wilkins and Hosni (2000).

*See Table 11 for descriptions of load densities.

air usually passes through the equipment at a density close to standard for locations below about 1000 ft, the accuracy desired normally requires no correction. When airflow is to be measured at a particular condition or point, such as at a coil entrance or exit, the corresponding specific volume can be read from the sea-level psychrometric chart. For higher elevations, the mass flow rates of air must be adjusted and higher-elevation psychrometric charts or algorithms must be used.

Heat Gain Calculations Using Standard Air Values

Air-conditioning design often requires the following information:

1. Total heat

Total heat gain q_t corresponding to the change of a given standard flow rate Q_s through an enthalpy difference Δh is

$$q_t = 60 \times 0.075 Q_s \Delta h = 4.5 Q_s \Delta h \tag{8}$$

where 60 = min/h, 0.075 = lb_{da}/ft³.

This total heat equation can also be expressed as

$$q_t = C_t Q_s \Delta h$$

where $C_t = 4.5$ is the air total heat factor, in Btu/h·cfm per Btu/lb enthalpy h .

2. Sensible heat

Sensible heat gain q_s corresponding to the change of dry-bulb temperature Δt for given airflow (standard conditions) Q_s is

$$q_s = 60 \times 0.075(0.24 + 0.45W)Q_s \Delta t \quad (9)$$

where

0.24 = specific heat of dry air, Btu/lb·°F

W = humidity ratio, lb_w/lb_{da}

0.45 = specific heat of water vapor, Btu/lb·°F

The specific heats are for a range from about -100 to 200°F. When $W = 0$, the value of $60 \times 0.075(0.24 + 0.45W) = 1.08$; when $W = 0.01$, the value is 1.10; when $W = 0.02$, the value is 1.12; and when $W = 0.03$, the value is 1.14. Because a value of $W = 0.01$ approximates conditions found in many air-conditioning problems, the sensible heat change (in Btu/h) has traditionally been found as

$$q_s = 1.10Q_s \Delta t \quad (10)$$

This sensible heat equation can also be expressed as

$$q_s = C_s Q_s \Delta t$$

where $C_s = 1.1$ is the air sensible heat factor, in Btu/h·cfm·°F.

3. Latent heat

Latent heat gain q_l corresponding to the change of humidity ratio ΔW (in lb_{m,w}/lb_{m,da}) for given airflow (standard conditions) Q_s is

$$q_l = 60 \times 0.075 \times 1076Q_s \Delta W = 4840Q_s \Delta W \quad (11)$$

where 1076 Btu/lb is the approximate heat content of 50% rh vapor at 75°F less the heat content of water at 50°F. A common design condition for the space is 50% rh at 75°F, and 50°F is normal condensate temperature from cooling and dehumidifying coils.

This latent heat equation can also be expressed as

$$q_l = C_l Q_s \Delta W$$

where $C_l = 4840$ is the air latent heat factor, in Btu/h·cfm. When ΔW is in gr_w/lb_{m,da}, $C_l = 0.69$ Btu/h·cfm.

4. Altitude correction for total, sensible, and latent heat equations

The constants 4.5, 1.10, and 4840 are useful in air-conditioning calculations at sea level (14.696 psia) and for normal temperatures and moisture ratios. For other conditions, more precise values should be used. For an altitude of 5000 ft (12.2 psia), appropriate values are 3.74, 0.92, and 4027. Equations (9) to (11) can be corrected for altitudes other than sea level by multiplying them by the ratio of pressure at sea level divided by the pressure at actual altitude. This can be derived from Equation (3) in Chapter 1 as

$$C_{x,alt} = C_{x,0} P/P_0$$

where $C_{x,0}$ is any of the sea-level C values and $P/P_0 = [1 - \text{elevation} \times (6.8754 \times 10^{-6})]^{5.2559}$, where elevation is in feet.

LATENT HEAT GAIN FROM MOISTURE DIFFUSION

Diffusion of moisture through building materials is a natural phenomenon that is always present. Chapters 25 to 27 cover principles, materials, and specific methods used to control moisture. Moisture transfer through walls and roofs is often neglected in comfort air conditioning because the actual rate is quite small and the corresponding latent heat gain is insignificant. Permeability and permeance values for various building materials are given in Chapter 26. Vapor retarders should be specified and installed in the proper location to keep moisture transfer to a minimum, and to minimize condensation within the envelope. Moisture migration up through slabs-on-grade and basement floors has been found to be significant, but has historically not been addressed in cooling load calculations. Under-slab continuous moisture retarders and drainage can reduce upward moisture flow.

Some industrial applications require low moisture to be maintained in a conditioned space. In these cases, the latent heat gain accompanying moisture transfer through walls and roofs may be greater than any other latent heat gain. This gain is computed by

$$q_{l_m} = (M/7000)A\Delta p_v(h_g - h_f) \quad (12)$$

where

q_{l_m} = latent heat gain from moisture transfer, Btu/h

M = permeance of wall or roof assembly, perms or grains/(ft²·h·in. Hg)

7000 = grains/lb

A = area of wall or roof surface, ft²

Δp_v = vapor pressure difference, in. Hg

h_g = enthalpy at room conditions, Btu/lb

h_f = enthalpy of water condensed at cooling coil, Btu/lb

$h_g - h_f = 1076$ Btu/lb when room temperature is 75°F and condensate off coil is 50°F

OTHER LATENT LOADS

Moisture sources within a building (e.g., shower areas, swimming pools or natatoriums, arboretums) can also contribute to latent load. Unlike sensible loads, which correlate to supply air quantities required in a space, latent loads usually only affect cooling coils sizing or refrigeration load. Because air from showers and some other moisture-generating areas is exhausted completely, those airborne latent loads do not reach the cooling coil and thus do not contribute to cooling load. However, system loads associated with ventilation air required to make up exhaust air must be recognized, and any recirculated air's moisture must be considered when sizing the dehumidification equipment.

For natatoriums, occupant comfort and humidity control are critical. In many instances, size, location, and environmental requirements make complete exhaust systems expensive and ineffective. Where recirculating mechanical cooling systems are used, evaporation (latent) loads are significant. Chapter 4 of the 2007 *ASHRAE Handbook—HVAC Applications* provides guidance on natatorium load calculations.

FENESTRATION HEAT GAIN

For spaces with neutral or positive air pressurization, the primary weather-related variable affecting cooling load is solar radiation. The effect of solar radiation is more pronounced and immediate on exposed, nonopaque surfaces. Chapter 14 includes procedures for calculating clear-sky solar radiation intensity and incidence angles for weather conditions encountered at specific locations. That chapter also includes some useful solar equations. Calculation of solar heat gain and conductive heat transfer through various glazing materials and associated mounting frames, with or without interior and/or exterior shading devices, is discussed in Chapter 15. This chapter covers application of such data to overall heat gain evaluation, and conversion of calculated heat gain into a composite cooling load for the conditioned space.

FENESTRATION DIRECT SOLAR, DIFFUSE SOLAR, AND CONDUCTIVE HEAT GAINS

For fenestration heat gain, use the following equations:

Direct beam solar heat gain q_b :

$$q_b = AE_{t,b} \text{SHGC}(\theta) \text{IAC}(\theta, \Omega) \quad (13)$$

Diffuse solar heat gain q_d :

$$q_d = A(E_{t,d} + E_{t,r})(\text{SHGC})_D \text{IAC}_D \quad (14)$$

Conductive heat gain q_c :

$$q_c = UA(T_{out} - T_{in}) \quad (15)$$

Total fenestration heat gain Q :

$$Q = q_b + q_d + q_c \quad (16)$$

where

- A = window area, ft²
- $E_{t,b}$, $E_{t,d}$, and $E_{t,r}$ = beam, sky diffuse, and ground-reflected diffuse irradiance, calculated using equations in Chapter 14
- SHGC(θ) = beam solar heat gain coefficient as a function of incident angle θ ; may be interpolated between values in Table 10 of Chapter 15
- (SHGC)_D = diffuse solar heat gain coefficient (also referred to as hemispherical SHGC); from Table 10 of Chapter 15
- T_{in} = inside temperature, °F
- T_{out} = outside temperature, °F
- U = overall U-factor, including frame and mounting orientation from Table 4 of Chapter 15, Btu/h·ft²·°F
- IAC(θ, Ω) = indoor solar attenuation coefficient for beam solar heat gain coefficient; = 1.0 if no inside shading device. IAC(θ, Ω) is a function of shade type and, depending on type, may also be a function of beam solar angle of incidence θ and shade geometry
- IAC_D = indoor solar attenuation coefficient for diffuse solar heat gain coefficient; = 1.0 if not inside shading device. IAC_D is a function of shade type and, depending on type, may also be a function of shade geometry

If specific window manufacturer's SHGC and U-factor data are available, those should be used. For fenestration equipped with inside shading (blinds, drapes, or shades), the indoor solar attenuation coefficients IAC(θ, Ω) and IAC_D are listed in Tables 13A to 13G of Chapter 15.

Note that, as discussed in Chapter 15, fenestration ratings (U-factor and SHGC) are based on the entire product area, including frames. Thus, for load calculations, fenestration area is the area of the entire opening in the wall or roof.

EXTERIOR SHADING

Nonuniform exterior shading, caused by roof overhangs, side fins, or building projections, requires separate hourly calculations for the externally shaded and unshaded areas of the window in question, with the inside shading SHGC still used to account for any internal shading devices. The areas, shaded and unshaded, depend on the location of the shadow line on a surface in the plane of the glass. Sun (1968) developed fundamental algorithms for analysis of shade patterns. McQuiston and Spitler (1992) provide graphical data to facilitate shadow line calculation.

Equations for calculating shade angles [Chapter 15, Equations (39) to (42)] can be used to determine the shape and area of a moving shadow falling across a given window from external shading elements during the course of a design day. Thus, a subprofile of heat gain for that window can be created by separating its sunlit and shaded areas for each hour.

HEAT BALANCE METHOD

Cooling load estimation involves calculating a surface-by-surface conductive, convective, and radiative heat balance for each room surface and a convective heat balance for the room air. These principles form the foundation for all methods described in this chapter. The heat balance (HB) method solves the problem directly instead of introducing transformation-based procedures. The advantages are that it contains no arbitrarily set parameters, and no processes are hidden from view.

Some computations required by this rigorous approach require the use of computers. The heat balance procedure is not new. Many energy calculation programs have used it in some form for many years. The first implementation that incorporated all the elements to

form a complete method was NBSLD (Kusuda 1967). The heat balance procedure is also implemented in both the BLAST and TARP energy analysis programs (Walton 1983). Before ASHRAE research project RP-875, the method had never been described completely or in a form applicable to cooling load calculations. The papers resulting from RP-875 describe the heat balance procedure in detail (Liesen and Pedersen 1997; McClellan and Pedersen 1997; Pedersen et al. 1997).

The HB method is codified in the software called Hbfort that accompanies Cooling and Heating Load Calculation Principles (Pedersen et al. 1998).

ASHRAE research project RP-1117 constructed two model rooms for which cooling loads were physically measured using extensive instrumentation (Chantrasrisalai et al. 2003; Eldridge et al. 2003; Iu et al. 2003). HB calculations closely approximated measured cooling loads when provided with detailed data for the test rooms.

ASSUMPTIONS

All calculation procedures involve some kind of model; all models require simplifying assumptions and, therefore, are approximate. The most fundamental assumption is that air in the thermal zone can be modeled as **well mixed**, meaning its temperature is uniform throughout the zone. ASHRAE research project RP-664 (Fisher and Pedersen 1997) established that this assumption is valid over a wide range of conditions.

The next major assumption is that the surfaces of the room (walls, windows, floor, etc.) can be treated as having

- Uniform surface temperatures
- Uniform long-wave (LW) and short-wave (SW) irradiation
- Diffuse radiating surfaces
- One-dimensional heat conduction within

The resulting formulation is called the **heat balance (HB) model**. Note that the assumptions, although common, are quite restrictive and set certain limits on the information that can be obtained from the model.

ELEMENTS

Within the framework of the assumptions, the HB can be viewed as four distinct processes:

1. Outside-face heat balance
2. Wall conduction process
3. Inside-face heat balance
4. Air heat balance

Figure 5 shows the relationship between these processes for a single opaque surface. The top part of the figure, inside the shaded box, is repeated for each surface enclosing the zone. The process for transparent surfaces is similar, but the absorbed solar component appears in the conduction process block instead of at the outside face, and the absorbed component splits into inward- and outward-flowing fractions. These components participate in the surface heat balances.

Outside-Face Heat Balance

The heat balance on the outside face of each surface is

$$q''_{sol} + q''_{LWR} + q''_{conv} - q''_{ko} = 0 \quad (17)$$

where

- q''_{sol} = absorbed direct and diffuse solar radiation flux (q/A), Btu/h·ft²
- q''_{LWR} = net long-wave radiation flux exchange with air and surroundings, Btu/h·ft²
- q''_{conv} = convective exchange flux with outside air, Btu/h·ft²
- q''_{ko} = conductive flux (q/A) into wall, Btu/h·ft²

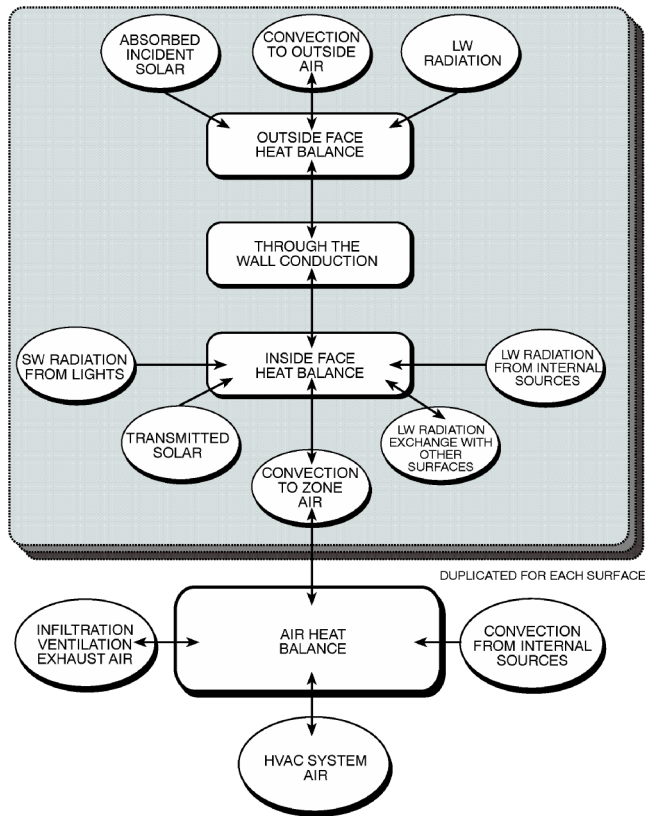

Fig. 5 Schematic of Heat Balance Processes in Zone

All terms are positive for net flux to the face except q''_{ko} , which is traditionally taken to be positive from outside to inside the wall.

Each term in Equation (17) has been modeled in several ways, and in simplified methods the first three terms are combined by using the sol-air temperature.

Wall Conduction Process

The wall conduction process has been formulated in more ways than any of the other processes. Techniques include

- Numerical finite difference
- Numerical finite element
- Transform methods
- Time series methods

This process introduces part of the time dependence inherent in load calculation. Figure 6 shows surface temperatures on the inside and outside faces of the wall element, and corresponding conductive heat fluxes away from the outside face and toward the inside face. All four quantities are functions of time. Direct formulation of the process uses temperature functions as input or known quantities, and heat fluxes as outputs or resultant quantities.

In some models, surface heat transfer coefficients are included as part of the wall element, making the temperatures in question the inside and outside air temperatures. This is not a desirable formulation, because it hides the heat transfer coefficients and prohibits changing them as airflow conditions change. It also prohibits treating the internal long-wave radiation exchange appropriately.

Because heat balances on both sides of the element induce both the temperature and heat flux, the solution must deal with this simultaneous condition. Two computational methods that have been used widely are finite difference and conduction transfer function methods. Because of the computational time advantage, the conduction

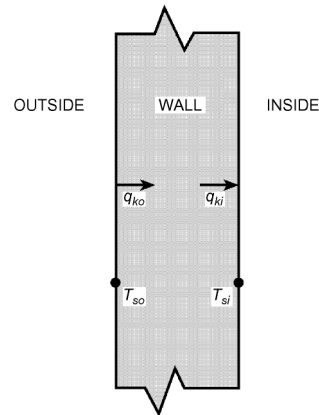

Fig. 6 Schematic of Wall Conduction Process

transfer function formulation has been selected for presentation here.

Inside-Face Heat Balance

The heart of the HB method is the internal heat balance involving the inside faces of the zone surfaces. This heat balance has many heat transfer components, and they are all coupled. Both long-wave (LW) and short-wave (SW) radiation are important, as well as wall conduction and convection to the air. The inside face heat balance for each surface can be written as follows:

$$q''_{LWX} + q''_{SW} + q''_{LWS} + q''_{ki} + q''_{sol} + q''_{conv} = 0 \quad (18)$$

where

q''_{LWX} = net long-wave radiant flux exchange between zone surfaces, Btu/h·ft²

q''_{SW} = net short-wave radiation flux to surface from lights, Btu/h·ft²

q''_{LWS} = long-wave radiation flux from equipment in zone, Btu/h·ft²

q''_{ki} = conductive flux through wall, Btu/h·ft²

q''_{sol} = transmitted solar radiative flux absorbed at surface, Btu/h·ft²

q''_{conv} = convective heat flux to zone air, Btu/h·ft²

These terms are explained in the following paragraphs.

LW Radiation Exchange Among Zone Surfaces. The limiting cases for modeling internal LW radiation exchange are

- Zone air is completely transparent to LW radiation
- Zone air completely absorbs LW radiation from surfaces in the zone

Most HB models treat air as completely transparent and not participating in LW radiation exchange among surfaces in the zone. The second model is attractive because it can be formulated simply using a combined radiative and convective heat transfer coefficient from each surface to the zone air and thus decouples radiant exchange among surfaces in the zone. However, because the transparent air model allows radiant exchange and is more realistic, the second model is inferior.

Furniture in a zone increases the amount of surface area that can participate in radiative and convective heat exchanges. It also adds thermal mass to the zone. These two changes can affect the time response of the zone cooling load.

SW Radiation from Lights. The short-wavelength radiation from lights is usually assumed to be distributed over the surfaces in the zone in some manner. The HB procedure retains this approach but allows the distribution function to be changed.

LW Radiation from Internal Sources. The traditional model for this source defines a radiative/convective split for heat introduced into a zone from equipment. The radiative part is then distributed over the zone's surfaces in some manner. This model is not completely realistic, and it departs from HB principles. In a true HB

model, equipment surfaces are treated just as other LW radiant sources within the zone. However, because information about the surface temperature of equipment is rarely known, it is reasonable to keep the radiative/convective split concept even though it ignores the true nature of the radiant exchange. ASHRAE research project RP-1055 (Hosni et al. 1999) determined radiative/convective splits for many additional equipment types, as listed in footnotes for Tables 8 and 9.

Transmitted Solar Heat Gain. Chapter 15’s calculation procedure for determining transmitted solar energy through fenestration uses the solar heat gain coefficient (SHGC) directly rather than relating it to double-strength glass, as is done when using a shading coefficient (SC). The difficulty with this plan is that the SHGC includes both transmitted solar and inward-flowing fraction of the solar radiation absorbed in the window. With the HB method, this latter part should be added to the conduction component so it can be included in the inside-face heat balance.

Transmitted solar radiation is also distributed over surfaces in the zone in a prescribed manner. It is possible to calculate the actual position of beam solar radiation, but this involves partial surface irradiation, which is inconsistent with the rest of the zone model, which assumes uniform conditions over an entire surface.

Using SHGC to Calculate Solar Heat Gain

The total solar heat gain through fenestration consists of directly transmitted solar radiation plus the inward-flowing fraction of solar radiation that is absorbed in the glazing system. Both parts contain beam and diffuse contributions. Transmitted radiation goes directly onto surfaces in the zone and is accounted for in the surface inside heat balance. The zone heat balance model accommodates the resulting heat fluxes without difficulty. The second part, the inward-flowing fraction of the absorbed solar radiation, interacts with other surfaces of the enclosure through long-wave radiant exchange and with zone air through convective heat transfer. As such, it is dependent both on geometric and radiative properties of the zone enclosure and convection characteristics inside and outside the zone. The solar heat gain coefficient (SHGC) combines the transmitted solar radiation and the inward-flowing fraction of the absorbed radiation. The SHGC is defined as

$$SHGC = \tau + \sum_{k=1}^n N_k \alpha_k \tag{19}$$

where

- τ = solar transmittance of glazing
- α_k = solar absorptance of the k th layer of the glazing system
- n = number of layers
- N_k = inward-flowing fraction of absorbed radiation in the k th layer

Note that Equation (19) is written generically. It can be written for a specific incidence angle and/or radiation wavelength and integrated over the wavelength and/or angle, but the principle is the same in each case. Refer to Chapter 15 for the specific expressions.

Unfortunately, the inward-flowing fraction N interacts with the zone in many ways. This interaction can be expressed as

$$N = f(\text{inside convection coefficient, outside convection coefficient, glazing system overall heat transfer coefficient, zone geometry, zone radiation properties})$$

The only way to model these interactions correctly is to combine the window model with the zone heat balance model and solve both simultaneously. This has been done recently in some energy analysis programs, but is not generally available in load calculation procedures. In addition, the SHGC used for rating glazing systems is based on specific values of the inside, outside, and overall heat transfer coefficients and does not include any zonal long-wavelength radiation considerations. So, the challenge is to devise a way to use SHGC values within the framework of heat balance calculation in the most accurate way possible, as discussed in the following paragraphs.

Using SHGC Data. The normal incidence SHGC used to rate and characterize glazing systems is not sufficient for determining solar heat gain for load calculations. These calculations require solar heat gain as a function of the incident solar angle in order to determine the hour-by-hour gain profile. Thus, it is necessary to use angular SHGC values and also diffuse SHGC values. These can be obtained from the WINDOW 5.2 program (LBL 2003). This program does a detailed optical and thermal simulation of a glazing system and, when applied to a single clear layer, produces the information shown in Table 13.

Table 13 shows the parameters as a function of incident solar angle and also the diffuse values. The specific parameters shown are

- V_{tc} = transmittance in visible spectrum
- R_{fv} and R_{bv} = front and back surface visible reflectances
- T_{sol} = solar transmittance [τ in Equations (19), (20), and (21)]
- R_f and R_b = front and back surface solar reflectances
- A_{bs1} = solar absorptance for layer 1, which is the only layer in this case [α in Equations (19), (20), and (21)]
- SHGC = solar heat gain coefficient at the center of the glazing

The parameters used for heat gain calculations are T_{sol} , A_{bs} , and SHGC. For the specific convective conditions assumed in WINDOW 5.2 program, the inward-flowing fraction of the absorbed solar can be obtained by rearranging Equation (19) to give

$$N_k \alpha_k = SHGC - \tau \tag{20}$$

This quantity, when multiplied by the appropriate incident solar intensity, provides the amount of absorbed solar radiation that flows

Table 13 Single-Layer Glazing Data Produced by WINDOW 5.2

Parameter	Incident Angle										Diffuse (Hemis.)
	0	10	20	30	40	50	60	70	80	90	
V_{tc}	0.899	0.899	0.898	0.896	0.889	0.870	0.822	0.705	0.441	0	0.822
R_{fv}	0.083	0.083	0.083	0.085	0.091	0.109	0.156	0.272	0.536	1	0.148
R_{bv}	0.083	0.083	0.083	0.085	0.091	0.109	0.156	0.272	0.536	1	0.148
T_{sol}	0.834	0.833	0.831	0.827	0.818	0.797	0.749	0.637	0.389	0	0.753
R_f	0.075	0.075	0.075	0.077	0.082	0.099	0.143	0.253	0.506	1	0.136
R_b	0.075	0.075	0.075	0.077	0.082	0.099	0.143	0.253	0.506	1	0.136
A_{bs1}	0.091	0.092	0.094	0.096	0.100	0.104	0.108	0.110	0.105	0	0.101
SHGC	0.859	0.859	0.857	0.854	0.845	0.825	0.779	0.667	0.418	0	0.781

Source: LBL (2003).

inward. In the heat balance formulation for zone loads, this heat flux is combined with that caused by conduction through glazing and included in the surface heat balance.

The outward-flowing fraction of absorbed solar radiation is used in the heat balance on the outside face of the glazing and is determined from

$$(1 - N_k) \alpha_k = \alpha_k - N_k \alpha_k = \alpha_k - (\text{SHGC} - \tau) \quad (21)$$

If there is more than one layer, the appropriate summation of absorptances must be done.

There is some potential inaccuracy in using the WINDOW 5.2 SHGC values because the inward-flowing fraction part was determined under specific conditions for the inside and outside heat transfer coefficients. However, the program can be run with inside and outside coefficients of one's own choosing. Normally, however, this effect is not large, and only in highly absorptive glazing systems might cause significant error.

For solar heat gain calculations, then, it seems reasonable to use the generic window property data that comes from WINDOW 5.2. Considering Table 13, the procedure is as follows:

1. Determine angle of incidence for the glazing.
2. Determine corresponding SHGC.
3. Evaluate $N_k \alpha_k$ using Equation (19).
4. Multiply T_{sol} by incident beam radiation intensity to get transmitted beam solar radiation.
5. Multiply $N_k \alpha_k$ by incident beam radiation intensity to get inward-flowing absorbed heat.
6. Repeat steps 2 to 5 with diffuse parameters and diffuse radiation.
7. Add beam and diffuse components of transmitted and inward-flowing absorbed heat.

This procedure is incorporated into the HB method so the solar gain is calculated accurately for each hour.

Table 10 in Chapter 15 contains SHGC information for many additional glazing systems. That table is similar to Table 13 but is slightly abbreviated. Again, the information needed for heat gain calculations is T_{sol} , SHGC, and A_{bs} .

The same caution about the inside and outside heat transfer coefficients applies to the information in Table 13 in Chapter 31. Those values were also obtained with specific inside and outside heat transfer coefficients, and the inward-flowing fraction N is dependent upon those values.

Convection to Zone Air. Inside convection coefficients presented in past editions of this chapter and used in most load calculation procedures and energy programs are based on very old, natural convection experiments and do not accurately describe heat transfer coefficients in a mechanically ventilated zone. In previous load calculation procedures, these coefficients were buried in the procedures and could not be changed. A heat balance formulation keeps them as working parameters. In this way, research results such as those from ASHRAE research project RP-664 (Fisher 1998) can be incorporated into the procedures. It also allows determining the sensitivity of the load calculation to these parameters.

Air Heat Balance

In HB formulations aimed at determining cooling loads, the capacitance of air in the zone is neglected and the air heat balance is done as a quasisteady balance in each time period. Four factors contribute to the air heat balance:

$$q_{conv} + q_{CE} + q_{IV} + q_{sys} = 0 \quad (22)$$

where

- q_{conv} = convective heat transfer from surfaces, Btu/h
- q_{CE} = convective parts of internal loads, Btu/h
- q_{IV} = sensible load caused by infiltration and ventilation air, Btu/h
- q_{sys} = heat transfer to/from HVAC system, Btu/h

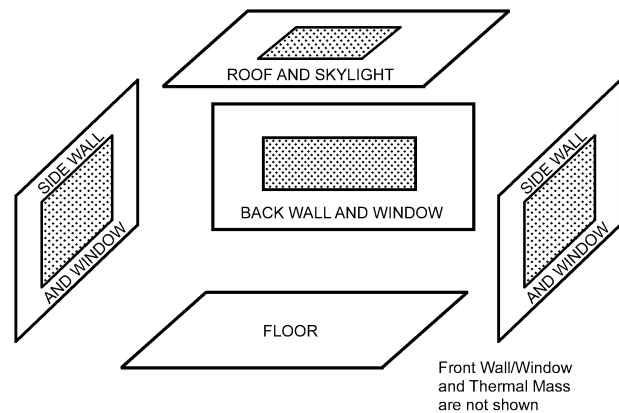

Fig. 7 Schematic View of General Heat Balance Zone

Convection from zone surfaces q_{conv} is the sum of all the convective heat transfer quantities from the inside-surface heat balance. This comes to the air through the convective heat transfer coefficient on the surfaces.

The **convective parts of the internal loads q_{CE}** is the companion to q''_{LWS} , the radiant contribution from internal loads [Equation (18)]. It is added directly to the air heat balance. This also violates the tenets of the HB approach, because surfaces producing internal loads exchange heat with zone air through normal convective processes. However, once again, this level of detail is generally not included in the heat balance, so it is included directly into the air heat balance instead.

In keeping with the well-mixed model for zone air, any air that enters directly to a space through **infiltration or ventilation q_{IV}** is immediately mixed with the zone's air. The amount of infiltration or natural ventilation air is uncertain. Sometimes it is related to the indoor/outdoor temperature difference and wind speed; however it is determined, it is added directly to the air heat balance.

Conditioned air that enters the zone from the HVAC system and provides q_{sys} is also mixed directly with the zone air. For commercial HVAC systems, ventilation air is most often provided using outside air as part of this mixed-in conditioned air; ventilation air is thus normally a system load rather than a direct-to-space load. An exception is where infiltration or natural ventilation is used to provide all or part of the ventilation air, as discussed in Chapter 16.

GENERAL ZONE FOR LOAD CALCULATION

The HB procedure is tailored to a single thermal zone, shown in Figure 7. The definition of a thermal zone depends on how the fixed temperature is controlled. If air circulated through an entire building or an entire floor is uniformly well stirred, the entire building or floor could be considered a thermal zone. On the other hand, if each room has a different control scheme, each room may need to be considered as a separate thermal zone. The framework needs to be flexible enough to accommodate any zone arrangement, but the heat balance aspect of the procedure also requires that a complete zone be described. This zone consists of four walls, a roof or ceiling, a floor, and a "thermal mass surface" (described in the section on Input Required). Each wall and the roof can include a window (or skylight in the case of the roof). This makes a total of 12 surfaces, any of which may have zero area if it is not present in the zone to be modeled.

The heat balance processes for this general zone are formulated for a 24 h steady-periodic condition. The variables are the inside and outside temperatures of the 12 surfaces plus either the HVAC system energy required to maintain a specified air temperature or the air temperature, if system capacity is specified. This makes a total of $25 \times 24 = 600$ variables. Although it is possible to set up the problem

for a simultaneous solution of these variables, the relatively weak coupling of the problem from one hour to the next allows a double iterative approach. One iteration is through all the surfaces in each hour, and the other is through the 24 h of a day. This procedure automatically reconciles nonlinear aspects of surface radiative exchange and other heat flux terms.

MATHEMATICAL DESCRIPTION

Conduction Process

Because it links the outside and inside heat balances, the wall conduction process regulates the cooling load's time dependence. For the HB procedure presented here, wall conduction is formulated using **conduction transfer functions (CTFs)**, which relate conductive heat fluxes to current and past surface temperatures and past heat fluxes. The general form for the inside heat flux is

$$q''_{ki}(t) = -Z_o T_{si, \theta} - \sum_{j=1}^{nz} Z_j T_{si, \theta-j\delta} + Y_o T_{so, \theta} + \sum_{j=1}^{nz} Y_j T_{so, \theta-j\delta} + \sum_{j=1}^{nq} \Phi_j q''_{ki, \theta-j\delta} \tag{23}$$

For outside heat flux, the form is

$$q''_{ko}(t) = -Y_o T_{si, \theta} - \sum_{j=1}^{nz} Y_j T_{si, \theta-j\delta} + X_o T_{so, \theta} + \sum_{j=1}^{nz} X_j T_{so, \theta-j\delta} + \sum_{j=1}^{nq} \Phi_j q''_{ko, \theta-j\delta} \tag{24}$$

where

- X_j = outside CTF, $j = 0, 1, \dots, nz$
- Y_j = cross CTF, $j = 0, 1, \dots, nz$
- Z_j = inside CTF, $j = 0, 1, \dots, nz$
- Φ_j = flux CTF, $j = 1, 2, \dots, nq$
- θ = time
- δ = time step
- T_{si} = inside-face temperature, °F
- T_{so} = outside-face temperature, °F
- q''_{ki} = conductive heat flux on inside face, Btu/h·ft²
- q''_{ko} = conductive heat flux on outside face, Btu/h·ft²

The subscript following the comma indicates the time period for the quantity in terms of time step δ . Also, the first terms in the series have been separated from the rest to facilitate solving for the current temperature in the solution scheme.

The two summation limits nz and nq depend on wall construction and also somewhat on the scheme used for calculating the CTFs. If $nq = 0$, the CTFs are generally referred to as **response factors**, but then theoretically nz is infinite. Values for nz and nq are generally set to minimize the amount of computation. A development of CTFs can be found in Hittle and Pedersen (1981).

Heat Balance Equations

The primary variables in the heat balance for the general zone are the 12 inside face temperatures and the 12 outside face temperatures at each of the 24 h, assigning i as the surface index and j as the hour index, or, in the case of CTFs, the sequence index. Thus, the primary variables are

$$T_{so,j} = \text{outside face temperature, } i = 1, 2, \dots, 12; j = 1, 2, \dots, 24$$

$$T_{si,j} = \text{inside face temperature, } i = 1, 2, \dots, 12; j = 1, 2, \dots, 24$$

In addition, $q_{sys,j}$ = cooling load, $j = 1, 2, \dots, 24$

Equations (17) and (24) are combined and solved for T_{so} to produce 12 equations applicable in each time step:

$$T_{so,i,j} = \left(\sum_{k=1}^{nz} T_{si,j-k} Y_{i,k} - \sum_{k=1}^{nz} T_{so,i,j-k} Z_{i,k} - \sum_{k=1}^{nq} \Phi_{i,k} q''_{ko,i,j-k} + q''_{asol,i,j} + q''_{LWR,i,j} + T_{si,i,j} Y_{i,0} + T_o h_{co,i,j} \right) / (Z_{i,0} + h_{co,i,j}) \tag{25}$$

where

- T_o = outside air temperature
- h_{co} = outside convection coefficient, introduced by using $q''_{conv} = h_{co}(T_o - T_{so})$

Equation (25) shows the need to separate $Z_{i,0}$, because the contribution of current surface temperature to conductive flux can be collected with the other terms involving that temperature.

Equations (18) and (23) are combined and solved for T_{si} to produce the next 12 equations:

$$T_{si,i,j} = \left(T_{si,i,j} Y_{i,0} + \sum_{k=1}^{nz} T_{so,i,j-k} Y_{i,k} - \sum_{k=1}^{nz} T_{si,i,j-k} Z_{i,k} + \sum_{k=1}^{nq} \Phi_{i,k} q''_{ki,i,j-k} + T_{a,j} h_{ci,j} + q''_{LWS} + q''_{LWX} + q''_{SW} + q''_{sol} e \right) / (Z_{i,0} + h_{ci,i,j}) \tag{26}$$

where

- T_a = zone air temperature
- h_{ci} = convective heat transfer coefficient on the inside, obtained from $q''_{conv} = h_{ci}(T_a - T_{si})$

Note that in Equations (25) and (26), the opposite surface temperature at the current time appears on the right-hand side. The two equations could be solved simultaneously to eliminate those variables. Depending on the order of updating the other terms in the equations, this can have a beneficial effect on solution stability.

The remaining equation comes from the air heat balance, Equation (22). This provides the cooling load q_{sys} at each time step:

$$q_{sys,j} = \sum_{i=1}^{12} A_i h_{ci} (T_{si,i,j} - T_{a,j}) + q_{CE} + q_{IV} \tag{27}$$

In Equation (27), the convective heat transfer term is expanded to show the interconnection between the surface temperatures and the cooling load.

Overall HB Iterative Solution

The iterative HB procedure consists of a series of initial calculations that proceed sequentially, followed by a double iteration loop, as shown in the following steps:

1. Initialize areas, properties, and face temperatures for all surfaces, 24 h.
2. Calculate incident and transmitted solar flux for all surfaces and hours.
3. Distribute transmitted solar energy to all inside faces, 24 h.
4. Calculate internal load quantities for all 24 h.
5. Distribute LW, SW, and convective energy from internal loads to all surfaces for all hours.
6. Calculate infiltration and direct-to-space ventilation loads for all hours.
7. Iterate the heat balance according to the following scheme:

```

For Day = 1 to Maxdays
  For j = 1 to 24      {hours in the day}
    For Surfcelter = 1 to Maxlter
      For i = 1 to 12  {The twelve zone surfaces}
        Evaluate Equations (34) and (35)
      Next i
    Next Surfcelter
    Evaluate Equation (36)
  Next j
If not converged, Next Day

```

8. Display results.

Generally, four or six surface iterations are sufficient to provide convergence. The convergence check on the day iteration should be based on the difference between the inside and the outside conductive heat flux terms q_k . A limit, such as requiring the difference between all inside and outside flux terms to be less than 1% of either flux, works well.

INPUT REQUIRED

Previous methods for calculating cooling loads attempted to simplify the procedure by precalculating representative cases and grouping the results with various correlating parameters. This generally tended to reduce the amount of information required to apply the procedure. With heat balance, no precalculations are made, so the procedure requires a fairly complete description of the zone.

Global Information. Because the procedure incorporates a solar calculation, some global information is required, including latitude, longitude, time zone, month, day of month, directional orientation of the zone, and zone height (floor to floor). Additionally, to take full advantage of the flexibility of the method to incorporate, for example, variable outside heat transfer coefficients, things such as wind speed, wind direction, and terrain roughness may be specified. Normally, these variables and others default to some reasonable set of values, but the flexibility remains.

Wall Information (Each Wall). Because the walls are involved in three of the fundamental processes (external and internal heat balance and wall conduction), each wall of the zone requires a fairly large set of variables. They include

- Facing angle with respect to solar exposure
- Tilt (degrees from horizontal)
- Area
- Solar absorptivity outside
- Long-wave emissivity outside
- Short-wave absorptivity inside
- Long-wave emissivity inside
- Exterior boundary temperature condition (solar versus nonsolar)
- External roughness
- Layer-by-layer construction information

Again, some of these parameters can be defaulted, but they are changeable, and they indicate the more fundamental character of the HB method because they are related to true heat transfer processes.

Window Information (Each Window). The situation for windows is similar to that for walls, but the windows require some additional information because of their role in the solar load. Necessary parameters include

- Area
- Normal solar transmissivity
- Normal SHGC
- Normal total absorptivity
- Long-wave emissivity outside
- Long-wave emissivity inside
- Surface-to-surface thermal conductance
- Reveal (for solar shading)

- Overhang width (for solar shading)
- Distance from overhang to window (for solar shading)

Roof and Floor Details. The roof and floor surfaces are specified similarly to walls. The main difference is that the ground outside boundary condition will probably be specified more often for a floor.

Thermal Mass Surface Details. An “extra” surface, called a thermal mass surface, can serve several functions. It is included in radiant heat exchange with the other surfaces in the space but is only exposed to the inside air convective boundary condition. As an example, this surface would be used to account for movable partitions in a space. Partition construction is specified layer by layer, similar to specification for walls, and those layers store and release heat by the same conduction mechanism as walls. As a general definition, the extra thermal mass surface should be sized to represent all surfaces in the space that are exposed to the air mass, except the walls, roof, floor, and windows. In the formulation, both sides of the thermal mass participate in the exchange.

Internal Heat Gain Details. The space can be subjected to several internal heat sources: people, lights, electrical equipment, and infiltration. Infiltration energy is assumed to go immediately into the air heat balance, so it is the least complicated of the heat gains. For the others, several parameters must be specified. These include the following fractions:

- Sensible heat gain
- Latent heat gain
- Short-wave radiation
- Long-wave radiation
- Energy that enters the air immediately as convection
- Activity level of people
- Lighting heat gain that goes directly to the return air

Radiant Distribution Functions. As mentioned previously, the generally accepted assumptions for the HB method include specifying the distribution of radiant energy from several sources to surfaces that enclose the space. This requires a distribution function that specifies the fraction of total radiant input absorbed by each surface. The types of radiation that require distribution functions are

- Long-wave, from equipment and lights
- Short-wave, from lights
- Transmitted solar

Other Required Information. Additional flexibility is included in the model so that results of research can be incorporated easily. This includes the capability to specify such things as

- Heat transfer coefficients/convection models
- Solar coefficients
- Sky models

The amount of input information required may seem extensive, but many parameters can be set to default values in most routine applications. However, all parameters listed can be changed when necessary to fit unusual circumstances or when additional information is obtained.

RADIANT TIME SERIES (RTS) METHOD

The radiant time series (RTS) method is a simplified method for performing design cooling load calculations that is derived from the heat balance (HB) method. It effectively replaces all other simplified (non-heat-balance) methods, such as the transfer function method (TFM), the cooling load temperature difference/cooling load factor (CLTD/CLF) method, and the total equivalent temperature difference/time averaging (TETD/TA) method.

This method was developed to offer a method that is rigorous, yet does not require iterative calculations, and that quantifies each component's contribution to the total cooling load. In addition, it is

desirable for the user to be able to inspect and compare the coefficients for different construction and zone types in a form illustrating their relative effect on the result. These characteristics of the RTS method make it easier to apply engineering judgment during cooling load calculation.

The RTS method is suitable for peak design load calculations, but it should not be used for annual energy simulations because of its inherent limiting assumptions. Although simple in concept, RTS involves too many calculations for practical use as a manual method, although it can easily be implemented in a simple computerized spreadsheet, as illustrated in the examples. For a manual cooling load calculation method, refer to the CLTD/CLF method in Chapter 28 of the 1997 *ASHRAE Handbook—Fundamentals*.

ASSUMPTIONS AND PRINCIPLES

Design cooling loads are based on the assumption of **steady-periodic conditions** (i.e., the design day’s weather, occupancy, and heat gain conditions are identical to those for preceding days such that the loads repeat on an identical 24 h cyclical basis). Thus, the heat gain for a particular component at a particular hour is the same as 24 h prior, which is the same as 48 h prior, etc. This assumption is the basis for the RTS derivation from the HB method.

Cooling load calculations must address two time-delay effects inherent in building heat transfer processes:

- (1) Delay of conductive heat gain through opaque massive exterior surfaces (walls, roofs, or floors)
- (2) Delay of radiative heat gain conversion to cooling loads.

Exterior walls and roofs conduct heat because of temperature differences between outdoor and indoor air. In addition, solar energy on exterior surfaces is absorbed, then transferred by conduction to the building interior. Because of the mass and thermal capacity of the wall or roof construction materials, there is a substantial time delay in heat input at the exterior surface becoming heat gain at the interior surface.

As described in the section on Cooling Load Principles, most heat sources transfer energy to a room by a combination of convection and radiation. The convective part of heat gain immediately

becomes cooling load. The radiative part must first be absorbed by the finishes and mass of the interior room surfaces, and becomes cooling load only when it is later transferred by convection from those surfaces to the room air. Thus, radiant heat gains become cooling loads over a delayed period of time.

OVERVIEW

Figure 8 gives an overview of the RTS method. When calculating solar radiation, transmitted solar heat gain through windows, sol-air temperature, and infiltration, RTS is exactly the same as previous simplified methods (TFM and TETD/TA). Important areas that differ from previous simplified methods include

- Computation of conductive heat gain
- Splitting of all heat gains into radiant and convective portions
- Conversion of radiant heat gains into cooling loads

The RTS method accounts for both conduction time delay and radiant time delay effects by multiplying hourly heat gains by 24 h time series. The time series multiplication, in effect, distributes heat gains over time. Series coefficients, which are called **radiant time factors** and **conduction time factors**, are derived using the HB method. Radiant time factors reflect the percentage of an earlier radiant heat gain that becomes cooling load during the current hour. Likewise, conduction time factors reflect the percentage of an earlier heat gain at the exterior of a wall or roof that becomes heat gain at the inside during the current hour. By definition, each radiant or conduction time series must total 100%.

These series can be used to easily compare the time-delay effect of one construction versus another. This ability to compare choices is of particular benefit during design, when all construction details may not have been decided. Comparison can illustrate the magnitude of difference between the choices, allowing the engineer to apply judgment and make more informed assumptions in estimating the load.

Figure 9 illustrates CTS values for three walls with similar U-factors but with light to heavy construction. Figure 10 illustrates CTS for three walls with similar construction but with different

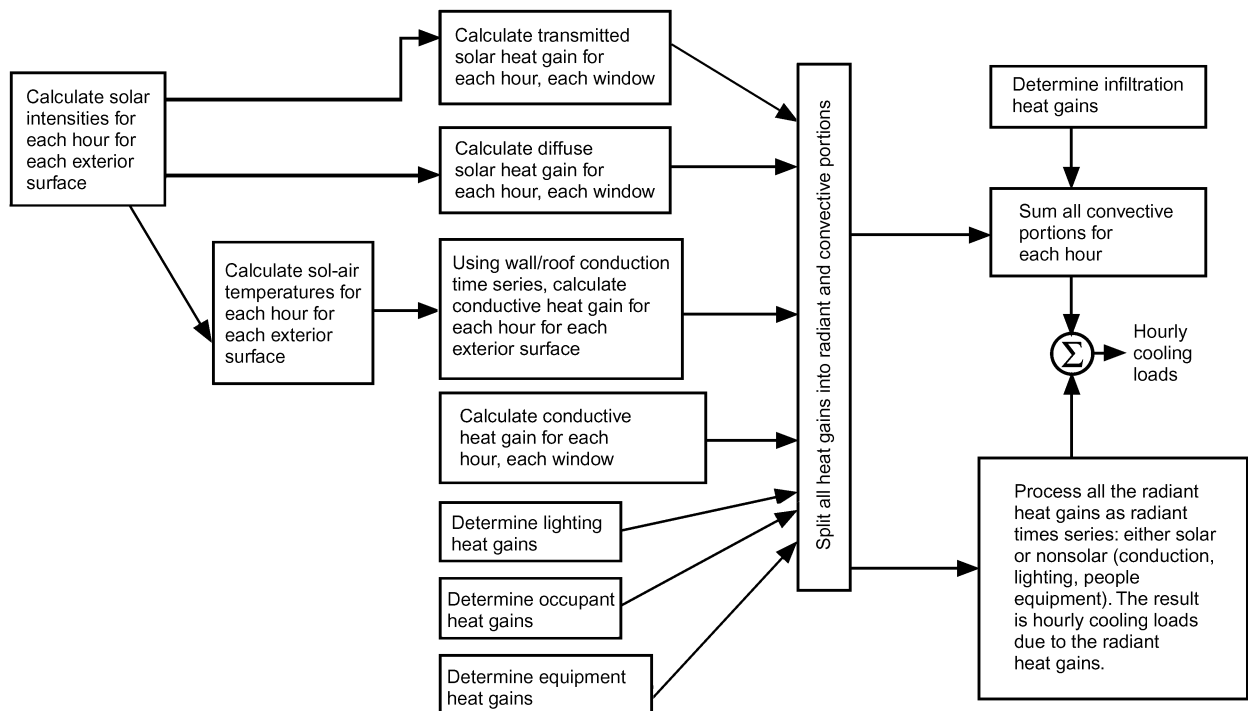

Fig. 8 Overview of Radiant Time Series Method

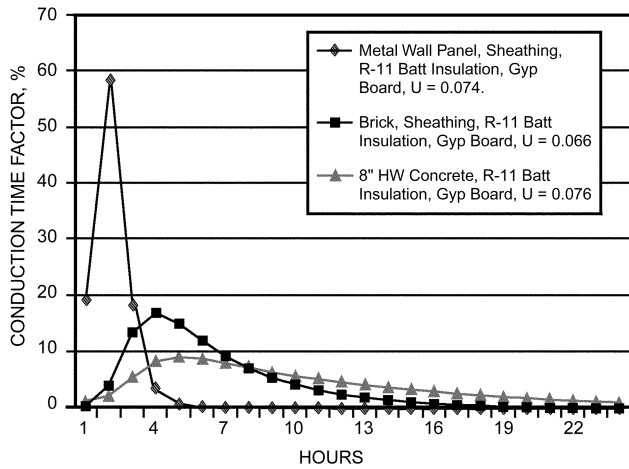

Fig. 9 CTS for Light to Heavy Walls

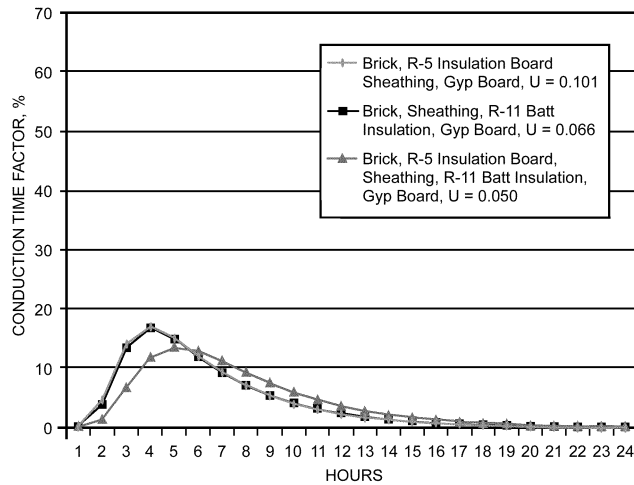

Fig. 10 CTS for Walls with Similar Mass and Increasing Insulation

amounts of insulation, thus with significantly different U-factors. Figure 11 illustrates RTS values for zones varying from light to heavy construction.

RTS PROCEDURE

The general procedure for calculating cooling load for each load component (lights, people, walls, roofs, windows, appliances, etc.) with RTS is as follows:

1. Calculate 24 h profile of component heat gains for design day (for conduction, first account for conduction time delay by applying conduction time series).
2. Split heat gains into radiant and convective parts (see Table 14 for radiant and convective fractions).
3. Apply appropriate radiant time series to radiant part of heat gains to account for time delay in conversion to cooling load.
4. Sum convective part of heat gain and delayed radiant part of heat gain to determine cooling load for each hour for each cooling load component.

After calculating cooling loads for each component for each hour, sum those to determine the total cooling load for each hour and select the hour with the peak load for design of the air-conditioning system. Repeat this process for multiple design months to determine the month when the peak load occurs, especially with windows on

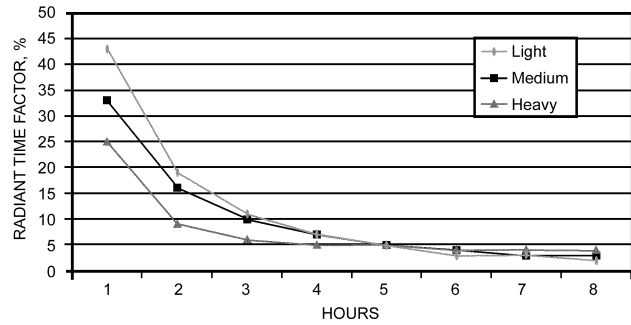

Fig. 11 RTS for Light to Heavy Construction

southern exposures (northern exposure in southern latitudes), which can result in higher peak room cooling loads in winter months than in summer.

HEAT GAIN THROUGH EXTERIOR SURFACES

Heat gain through exterior opaque surfaces is derived from the same elements of solar radiation and thermal gradient as that for fenestration areas. It differs primarily as a function of the mass and nature of the wall or roof construction, because those elements affect the rate of conductive heat transfer through the composite assembly to the interior surface.

Sol-Air Temperature

Sol-air temperature is the outdoor air temperature that, in the absence of all radiation changes gives the same rate of heat entry into the surface as would the combination of incident solar radiation, radiant energy exchange with the sky and other outdoor surroundings, and convective heat exchange with outdoor air.

Heat Flux into Exterior Sunlit Surfaces. The heat balance at a sunlit surface gives the heat flux into the surface q/A as

$$\frac{q}{A} = \alpha E_t + h_o(t_o - t_s) - \varepsilon \Delta R \tag{28}$$

where

- α = absorptance of surface for solar radiation
- E_t = total solar radiation incident on surface, Btu/h·ft²
- h_o = coefficient of heat transfer by long-wave radiation and convection at outer surface, Btu/h·ft²·°F
- t_o = outdoor air temperature, °F
- t_s = surface temperature, °F
- ε = hemispherical emittance of surface
- ΔR = difference between long-wave radiation incident on surface from sky and surroundings and radiation emitted by blackbody at outdoor air temperature, Btu/h·ft²

Assuming the rate of heat transfer can be expressed in terms of the sol-air temperature t_e ,

$$\frac{q}{A} = h_o(t_e - t_s) \tag{29}$$

and from Equations (28) and (29),

$$t_e = t_o + \frac{\alpha E_t}{h_o} - \frac{\varepsilon \Delta R}{h_o} \tag{30}$$

For **horizontal surfaces** that receive long-wave radiation from the sky only, an appropriate value of ΔR is about 20 Btu/h·ft², so that if $\varepsilon = 1$ and $h_o = 3.0$ Btu/h·ft²·°F, the long-wave correction term is about 7°F (Bliss 1961).

Table 14 Recommended Radiative/Convective Splits for Internal Heat Gains

Heat Gain Type	Recommended Radiative Fraction	Recommended Convective Fraction	Comments
Occupants, typical office conditions	0.6	0.4	See Table 1 for other conditions.
Equipment	0.1 to 0.8	0.9 to 0.2	See Tables 6 to 12 for details of equipment heat gain and recommended radiative/convective splits for motors, cooking appliances, laboratory equipment, medical equipment, office equipment, etc. Varies; see Table 3.
Office, with fan	0.10	0.9	
Without fan	0.3	0.7	
Lighting			
Conduction heat gain			
Through walls and floors	0.46	0.54	
Through roof	0.60	0.40	
Through windows	0.33 (SHGC > 0.5) 0.46 (SHGC < 0.5)	0.67 (SHGC > 0.5) 0.54 (SHGC < 0.5)	
Solar heat gain through fenestration			
Without interior shading	1.0	0.0	Varies; see Tables 13A to 13G in Chapter 15.
With interior shading			
Infiltration	0.0	1.0	

Source: Nigusse (2007).

Table 15 Solar Absorptance Values of Various Surfaces

Surface	Absorptance
Brick, red (Purdue) ^a	0.63
Paint	
Red ^b	0.63
Black, matte ^b	0.94
Sandstone ^b	0.50
White acrylic ^a	0.26
Sheet metal, galvanized	
New ^a	0.65
Weathered ^a	0.80
Shingles	0.82
Gray ^b	
Brown ^b	0.91
Black ^b	0.97
White ^b	0.75
Concrete ^{a,c}	0.60 to 0.83

^aIncropera and DeWitt (1990).

^bParker et al. (2000).

^cMiller (1971).

Because **vertical surfaces** receive long-wave radiation from the ground and surrounding buildings as well as from the sky, accurate ΔR values are difficult to determine. When solar radiation intensity is high, surfaces of terrestrial objects usually have a higher temperature than the outdoor air; thus, their long-wave radiation compensates to some extent for the sky's low emittance. Therefore, it is common practice to assume $\epsilon\Delta R = 0$ for vertical surfaces.

Tabulated Temperature Values. The sol-air temperatures in Example Cooling and Heating Load Calculations section have been calculated based on $\epsilon\Delta R/h_o$ values of 7°F for horizontal surfaces and 0°F for vertical surfaces; total solar intensity values used for the calculations were calculated using equations in Chapter 14.

Surface Colors. Sol-air temperature values are given in the Example Cooling and Heating Load Calculations section for two values of the parameter α/h_o ; the value of 0.15 is appropriate for a light-colored surface, whereas 0.30 represents the usual maximum value for this parameter (i.e., for a dark-colored surface or any surface for which the permanent lightness cannot reliably be anticipated). Solar absorptance values of various surfaces are included in Table 15.

This procedure was used to calculate the sol-air temperatures included in the Examples section. Because of the tedious solar angle and intensity calculations, using a simple computer spreadsheet or other software for these calculations can reduce the effort involved.

Calculating Conductive Heat Gain Using Conduction Time Series

In the RTS method, conduction through exterior walls and roofs is calculated using conduction time series (CTS). Wall and roof conductive heat input at the exterior is defined by the familiar conduction equation as

$$q_{i,0-n} = UA(t_{e,0-n} - t_{rc}) \tag{31}$$

where

- $q_{i,0-n}$ = conductive heat input for the surface n hours ago, Btu/h
- U = overall heat transfer coefficient for the surface, Btu/h · ft² · °F
- A = surface area, ft²
- $t_{e,0-n}$ = sol-air temperature n hours ago, °F
- t_{rc} = presumed constant room air temperature, °F

Conductive heat gain through walls or roofs can be calculated using conductive heat inputs for the current hours and past 23 h and conduction time series:

$$q_0 = c_0q_{i,0} + c_1q_{i,0-1} + c_2q_{i,0-2} + c_3q_{i,0-3} + \dots + c_{23}q_{i,0-23} \tag{32}$$

where

- q_0 = hourly conductive heat gain for the surface, Btu/h
- $q_{i,0}$ = heat input for the current hour
- $q_{i,0-n}$ = heat input n hours ago
- $c_0, c_1, \text{ etc.}$ = conduction time factors

Conduction time factors for representative wall and roof types are included in Tables 16 and 17. Those values were derived by first calculating conduction transfer functions for each example wall and roof construction. Assuming steady-periodic heat input conditions for design load calculations allows conduction transfer functions to be reformulated into periodic response factors, as demonstrated by Spitler and Fisher (1999a). The periodic response factors were further simplified by dividing the 24 periodic response factors by the respective overall wall or roof U-factor to form the conduction time series (CTS). The conduction time factors can then be used in Equation (32) and provide a way to compare time delay characteristics between different wall and roof constructions. Construction material

Table 16 Wall Conduction Time Series (CTS)

Wall Number =	CURTAIN WALLS			STUD WALLS				EIFS			BRICK WALLS									
	1	2	3	4	5	6	7	8	9	10	11	12	13	14	15	16	17	18	19	20
U-Factor, Btu/h·ft ² ·°F	0.075	0.076	0.075	0.074	0.074	0.071	0.073	0.118	0.054	0.092	0.101	0.066	0.050	0.102	0.061	0.111	0.124	0.091	0.102	0.068
Total R	13.3	13.2	13.3	13.6	13.6	14.0	13.8	8.5	18.6	10.8	9.9	15.1	20.1	9.8	16.3	9.0	8.1	11.0	9.8	14.6
Mass, lb/ft ²	6.3	4.3	16.4	5.2	17.3	5.2	13.7	7.5	7.8	26.8	42.9	44.0	44.2	59.6	62.3	76.2	80.2	96.2	182.8	136.3
Thermal Capacity, Btu/ft ² ·°F	1.5	1.0	3.3	1.2	3.6	1.6	3.0	1.8	1.9	5.9	8.7	8.7	8.7	11.7	12.4	15.7	15.3	19.0	38.4	28.4
Hour	Conduction Time Factors, %																			
0	18	25	8	19	6	7	5	11	2	1	0	0	0	1	2	2	1	3	4	3
1	58	57	45	59	42	44	41	50	25	2	5	4	1	1	2	2	1	3	4	3
2	20	15	32	18	33	32	34	26	31	6	14	13	7	2	2	2	3	3	4	3
3	4	3	11	3	13	12	13	9	20	9	17	17	12	5	3	4	6	3	4	4
4	0	0	3	1	4	4	4	3	11	9	15	15	13	8	5	5	7	3	4	4
5	0	0	1	0	1	1	2	1	5	9	12	12	13	9	6	6	8	4	4	4
6	0	0	0	0	1	0	1	0	3	8	9	9	11	9	7	6	8	4	4	5
7	0	0	0	0	0	0	0	0	2	7	7	7	9	9	7	7	8	5	4	5
8	0	0	0	0	0	0	0	0	1	6	5	5	7	8	7	7	8	5	4	5
9	0	0	0	0	0	0	0	0	0	6	4	4	6	7	7	6	7	5	4	5
10	0	0	0	0	0	0	0	0	0	5	3	3	5	7	6	6	6	5	4	5
11	0	0	0	0	0	0	0	0	0	5	2	2	4	6	6	6	6	5	5	5
12	0	0	0	0	0	0	0	0	0	4	2	2	3	5	5	5	5	5	5	5
13	0	0	0	0	0	0	0	0	0	4	1	2	2	4	5	5	4	5	5	5
14	0	0	0	0	0	0	0	0	0	3	1	2	2	4	5	5	4	5	5	5
15	0	0	0	0	0	0	0	0	0	3	1	1	1	3	4	4	3	5	4	4
16	0	0	0	0	0	0	0	0	0	3	1	1	1	3	4	4	3	5	4	4
17	0	0	0	0	0	0	0	0	0	2	1	1	1	2	3	4	3	4	4	4
18	0	0	0	0	0	0	0	0	0	2	0	0	1	2	3	3	2	4	4	4
19	0	0	0	0	0	0	0	0	0	2	0	0	1	2	3	3	2	4	4	4
20	0	0	0	0	0	0	0	0	0	2	0	0	0	1	3	3	2	4	4	4
21	0	0	0	0	0	0	0	0	0	1	0	0	0	1	2	2	1	4	4	4
22	0	0	0	0	0	0	0	0	0	1	0	0	0	1	2	2	1	4	4	3
23	0	0	0	0	0	0	0	0	0	0	0	0	0	0	1	1	1	3	4	3
Total Percentage	100	100	100	100	100	100	100	100	100	100	100	100	100	100	100	100	100	100	100	100
Layer ID from outside to inside (see Table 18)	F01	F01	F01	F01	F01	F01	F01	F01	F01	F01	F01	F01	F01	F01	F01	F01	F01	F01	F01	F01
	F09	F08	F10	F08	F10	F11	F07	F06	F06	F06	M01	M01	M01	M01	M01	M01	M01	M01	M01	M01
	F04	F04	F04	G03	G03	G02	G03	I01	I01	I01	F04	F04	F04	F04	F04	F04	F04	F04	F04	F04
	I02	I02	I02	I04	I04	I04	I04	G03	G03	G03	I01	G03	I01	I01	M03	I01	I01	I01	I01	M15
	F04	F04	F04	F01	G01	G04	G01	F04	I04	M03	G03	I04	G03	M03	I04	M05	M01	M13	M16	I04
	G01	G01	G01	F02	F02	F02	F02	G01	G01	F04	F04	G01	I04	F02	G01	G01	F02	F04	F04	G01
	F02	F02	F02	—	—	—	—	F02	F02	G01	G01	F02	G01	—	F02	F02	—	G01	G01	F02
	—	—	—	—	—	—	—	—	—	F02	F02	—	F02	—	—	—	—	F02	F02	—

Wall Number Descriptions

- | | |
|--|---|
| 1. Spandrel glass, R-10 insulation board, gyp board | 11. Brick, R-5 insulation board, sheathing, gyp board |
| 2. Metal wall panel, R-10 insulation board, gyp board | 12. Brick, sheathing, R-11 batt insulation, gyp board |
| 3. 1 in. stone, R-10 insulation board, gyp board | 13. Brick, R-5 insulation board, sheathing, R-11 batt insulation, gyp board |
| 4. Metal wall panel, sheathing, R-11 batt insulation, gyp board | 14. Brick, R-5 insulation board, 8 in. LW CMU |
| 5. 1 in. stone, sheathing, R-11 batt insulation, gyp board | 15. Brick, 8 in. LW CMU, R-11 batt insulation, gyp board |
| 6. Wood siding, sheathing, R-11 batt insulation, 1/2 in. wood | 16. Brick, R-5 insulation board, 8 in. HW CMU, gyp board |
| 7. 1 in. stucco, sheathing, R-11 batt insulation, gyp board | 17. Brick, R-5 insulation board, brick |
| 8. EIFS finish, R-5 insulation board, sheathing, gyp board | 18. Brick, R-5 insulation board, 8 in. LW concrete, gyp board |
| 9. EIFS finish, R-5 insulation board, sheathing, R-11 batt insulation, gyp board | 19. Brick, R-5 insulation board, 12 in. HW concrete, gyp board |
| 10. EIFS finish, R-5 insulation board, sheathing, 8 in. LW CMU, gyp board | 20. Brick, 8 in. HW concrete, R-11 batt insulation, gyp board |

data used in the calculations for walls and roofs in Tables 16 and 17 are listed in Table 18.

Heat gains calculated for walls or roofs using periodic response factors (and thus CTS) are identical to those calculated using conduction transfer functions for the steady periodic conditions assumed in design cooling load calculations. The methodology for calculating periodic response factors from conduction transfer functions was originally developed as part of ASHRAE research project RP-875 (Spitler and Fisher 1999b; Spitler et al. 1997). For walls and roofs that are not reasonably close to the representative constructions in Tables 16 and 17, CTS coefficients may be computed with a computer program such as that described by Iu and

Fisher (2004). For walls and roofs with thermal bridges, the procedure described by Karambakkam et al. (2005) may be used to determine an equivalent wall construction, which can then be used as the basis for finding the CTS coefficients. When considering the level of detail needed to make an adequate approximation, remember that, for buildings with windows and internal heat gains, the conduction heat gains make up a relatively small part of the cooling load. For heating load calculations, the conduction heat loss may be more significant.

The tedious calculations involved make a simple computer spreadsheet or other computer software a useful labor saver.

Table 16 Wall Conduction Time Series (CTS) (Concluded)

Wall Number =	CONCRETE BLOCK WALL						PRECAST AND CAST-IN-PLACE CONCRETE WALLS									
	21	22	23	24	25	26	27	28	29	30	31	32	33	34	35	
U-Factor, Btu/h·ft²·°F	0.067	0.059	0.073	0.186	0.147	0.121	0.118	0.074	0.076	0.115	0.068	0.082	0.076	0.047	0.550	
Total R	14.8	16.9	13.7	5.4	6.8	8.2	8.4	13.6	13.1	8.7	14.7	12.2	13.1	21.4	1.8	
Mass, lb/ft²	22.3	22.3	46.0	19.3	21.9	34.6	29.5	29.6	53.8	59.8	56.3	100.0	96.3	143.2	140.0	
Thermal Capacity, Btu/ft²·°F	4.8	4.8	10.0	4.1	4.7	7.4	6.1	6.1	10.8	12.1	11.4	21.6	20.8	30.9	30.1	
Hour	Conduction Time Factors, %															
0	0	1	0	1	0	1	1	0	1	2	1	3	1	2	1	
1	4	1	2	11	3	1	10	8	1	2	2	3	2	2	2	
2	13	5	8	21	12	2	20	18	3	3	3	4	5	3	4	
3	16	9	12	20	16	5	18	18	6	5	6	5	8	3	7	
4	14	11	12	15	15	7	14	14	8	6	7	6	9	5	8	
5	11	10	11	10	12	9	10	11	9	6	8	6	9	5	8	
6	9	9	9	7	10	9	7	8	9	6	8	6	8	6	8	
7	7	8	8	5	8	8	5	6	9	6	7	5	7	6	8	
8	6	7	7	3	6	8	4	4	8	6	7	5	6	6	7	
9	4	6	6	2	4	7	3	3	7	6	6	5	6	6	6	
10	3	5	5	2	3	6	2	2	7	5	6	5	5	6	6	
11	3	4	4	1	3	6	2	2	6	5	5	5	5	5	5	
12	2	4	3	1	2	5	1	2	5	5	5	4	4	5	4	
13	2	3	2	1	2	4	1	1	4	5	4	4	4	5	4	
14	2	3	2	0	1	4	1	1	4	4	4	4	3	4	4	
15	1	3	2	0	1	3	1	1	3	4	3	4	3	4	3	
16	1	2	1	0	1	3	0	1	2	4	3	4	3	4	3	
17	1	2	1	0	1	2	0	0	2	3	3	4	2	4	3	
18	1	2	1	0	0	2	0	0	1	3	2	4	2	4	2	
19	0	1	1	0	0	2	0	0	1	3	2	3	2	3	2	
20	0	1	1	0	0	2	0	0	1	3	2	3	2	3	2	
21	0	1	1	0	0	2	0	0	1	3	2	3	2	3	1	
22	0	1	1	0	0	1	0	0	1	3	2	3	1	3	1	
23	0	1	0	0	0	1	0	0	1	2	2	2	1	3	1	
Total Percentage	100	100	100	100	100	100	100	100	100	100	100	100	100	100	100	
Layer ID from outside to inside (see Table 18)	F01 M03 I04 G01 F02 —	F01 M08 I04 G01 F02 —	F01 F07 M05 I04 G01 F02	F01 M08 F02 — — —	F01 M08 F04 G01 F02 —	F01 M09 F04 G01 F02 —	F01 M11 I01 F04 G01 F02	F01 M11 I04 G01 F02 —	F01 M11 I02 M11 G01 F02	F01 F06 I01 M13 G01 F02	F01 M13 I04 G01 F02 —	F01 F06 I02 M15 G01 F02	F01 M15 I04 G01 F02 —	F01 M16 I05 G01 F02 —	F01 M16 I05 G01 F02 —	

Wall Number Descriptions

- 21. 8 in. LW CMU, R-11 batt insulation, gyp board
- 22. 8 in. LW CMU with fill insulation, R-11 batt insulation, gyp board
- 23. 1 in. stucco, 8 in. HW CMU, R-11 batt insulation, gyp board
- 24. 8 in. LW CMU with fill insulation
- 25. 8 in. LW CMU with fill insulation, gyp board
- 26. 12 in. LW CMU with fill insulation, gyp board
- 27. 4 in. LW concrete, R-5 board insulation, gyp board
- 28. 4 in. LW concrete, R-11 batt insulation, gyp board
- 29. 4 in. LW concrete, R-10 board insulation, 4 in. LW concrete
- 30. EIFS finish, R-5 insulation board, 8 in. LW concrete, gyp board
- 31. 8 in. LW concrete, R-11 batt insulation, gyp board
- 32. EIFS finish, R-10 insulation board, 8 in. HW concrete, gyp board
- 33. 8 in. HW concrete, R-11 batt insulation, gyp board
- 34. 12 in. HW concrete, R-19 batt insulation, gyp board
- 35. 12 in. HW concrete

HEAT GAIN THROUGH INTERIOR SURFACES

Whenever a conditioned space is adjacent to a space with a different temperature, heat transfer through the separating physical section must be considered. The heat transfer rate is given by

$$q = UA(t_b - t_i) \tag{33}$$

where

- q = heat transfer rate, Btu/h
- U = coefficient of overall heat transfer between adjacent and conditioned space, Btu/h·ft²·°F
- A = area of separating section concerned, ft²
- t_b = average air temperature in adjacent space, °F
- t_i = air temperature in conditioned space, °F

U-values can be obtained from Chapter 27. Temperature t_b may differ greatly from t_i . The temperature in a kitchen or boiler room, for

example, may be as much as 15 to 50°F above the outdoor air temperature. Actual temperatures in adjoining spaces should be measured, when possible. Where nothing is known except that the adjacent space is of conventional construction, contains no heat sources, and itself receives no significant solar heat gain, $t_b - t_i$ may be considered the difference between the outdoor air and conditioned space design dry-bulb temperatures minus 5°F. In some cases, air temperature in the adjacent space corresponds to the outdoor air temperature or higher.

Floors

For floors directly in contact with the ground or over an underground basement that is neither ventilated nor conditioned, sensible heat transfer may be neglected for cooling load estimates because usually there is a heat loss rather than a gain. An exception is in hot climates (i.e., where average outdoor air temperature exceeds

Table 17 Roof Conduction Time Series (CTS)

Roof Number	SLOPED FRAME ROOFS						WOOD DECK		METAL DECK ROOFS					CONCRETE ROOFS					
	1	2	3	4	5	6	7	8	9	10	11	12	13	14	15	16	17	18	19
U-Factor, Btu/h·ft²·°F	0.044	0.040	0.045	0.041	0.042	0.041	0.069	0.058	0.080	0.065	0.057	0.036	0.052	0.054	0.052	0.051	0.056	0.055	0.042
Total R Mass, lb/ft²	22.8	25.0	22.2	24.1	23.7	24.6	14.5	17.2	12.6	15.4	17.6	27.6	19.1	18.6	19.2	19.7	18.0	18.2	23.7
Thermal Capacity, Btu/ft²·°F	5.5	4.3	2.9	7.1	11.4	7.1	10.0	11.5	4.9	6.3	5.1	5.6	11.8	30.6	43.9	57.2	73.9	97.2	74.2
Hour	Conduction Time Factors, %																		
0	6	10	27	1	1	1	0	1	18	4	8	1	0	1	2	2	2	3	1
1	45	57	62	17	17	12	7	3	61	41	53	23	10	2	2	2	2	3	2
2	33	27	10	31	34	25	18	8	18	35	30	38	22	8	3	3	5	3	6
3	11	5	1	24	25	22	18	10	3	14	7	22	20	11	6	4	6	5	8
4	3	1	0	14	13	15	15	10	0	4	2	10	14	11	7	5	7	6	8
5	1	0	0	7	6	10	11	9	0	1	0	4	10	10	8	6	7	6	8
6	1	0	0	4	3	6	8	8	0	1	0	2	7	9	8	6	6	6	7
7	0	0	0	2	1	4	6	7	0	0	0	0	5	7	7	6	6	6	7
8	0	0	0	0	0	2	5	6	0	0	0	0	4	6	7	6	6	6	6
9	0	0	0	0	0	1	3	5	0	0	0	0	3	5	6	6	5	5	5
10	0	0	0	0	0	1	3	5	0	0	0	0	2	5	5	6	5	5	5
11	0	0	0	0	0	1	2	4	0	0	0	0	1	4	5	5	5	5	5
12	0	0	0	0	0	0	1	4	0	0	0	0	1	3	5	5	4	5	4
13	0	0	0	0	0	0	1	3	0	0	0	0	1	3	4	5	4	4	4
14	0	0	0	0	0	0	1	3	0	0	0	0	0	3	4	4	4	4	3
15	0	0	0	0	0	0	1	3	0	0	0	0	0	2	3	4	4	4	3
16	0	0	0	0	0	0	0	2	0	0	0	0	0	2	3	4	3	4	3
17	0	0	0	0	0	0	0	2	0	0	0	0	0	2	3	4	3	4	3
18	0	0	0	0	0	0	0	2	0	0	0	0	0	1	3	3	3	3	2
19	0	0	0	0	0	0	0	2	0	0	0	0	0	1	2	3	3	3	2
20	0	0	0	0	0	0	0	1	0	0	0	0	0	1	2	3	3	3	2
21	0	0	0	0	0	0	0	1	0	0	0	0	0	1	2	3	3	3	2
22	0	0	0	0	0	0	0	1	0	0	0	0	0	1	2	3	2	2	2
23	0	0	0	0	0	0	0	0	0	0	0	0	0	1	1	2	2	2	2
	100	100	100	100	100	100	100	100	100	100	100	100	100	100	100	100	100	100	100
Layer ID from outside to inside (see Table 18)	F01	F01	F01	F01	F01	F01	F01	F01	F01	F01	F01	F01	F01	F01	F01	F01	F01	F01	F01
	F08	F08	F08	F12	F14	F15	F13	F13	F13	F13	F13	F13	M17	F13	F13	F13	F13	F13	F13
	G03	G03	G03	G05	G05	G05	G03	G03	G03	G03	G03	G03	F13	G03	G03	G03	G03	G03	M14
	F05	F05	F05	F05	F05	F05	I02	I02	I02	I02	I03	I02	G03	I03	I03	I03	I03	I03	F05
	I05	I05	I05	I05	I05	I05	G06	G06	F08	F08	F08	I03	I03	M11	M12	M13	M14	M15	I05
	G01	F05	F03	F05	F05	F05	F03	F05	F03	F05	F03	F08	F08	F03	F03	F03	F03	F03	F16
	F03	F16	—	G01	G01	G01	—	F16	—	F16	—	—	F03	—	—	—	—	—	F03
	—	F03	—	F03	F03	F03	—	F03	—	F03	—	—	—	—	—	—	—	—	—

Roof Number Descriptions

- | | |
|--|---|
| 1. Metal roof, R-19 batt insulation, gyp board | 11. Membrane, sheathing, R-15 insulation board, metal deck |
| 2. Metal roof, R-19 batt insulation, suspended acoustical ceiling | 12. Membrane, sheathing, R-10 plus R-15 insulation boards, metal deck |
| 3. Metal roof, R-19 batt insulation | 13. 2 in. concrete roof ballast, membrane, sheathing, R-15 insulation board, metal deck |
| 4. Asphalt shingles, wood sheathing, R-19 batt insulation, gyp board | 14. Membrane, sheathing, R-15 insulation board, 4 in. LW concrete |
| 5. Slate or tile, wood sheathing, R-19 batt insulation, gyp board | 15. Membrane, sheathing, R-15 insulation board, 6 in. LW concrete |
| 6. Wood shingles, wood sheathing, R-19 batt insulation, gyp board | 16. Membrane, sheathing, R-15 insulation board, 8 in. LW concrete |
| 7. Membrane, sheathing, R-10 insulation board, wood deck | 17. Membrane, sheathing, R-15 insulation board, 6 in. HW concrete |
| 8. Membrane, sheathing, R-10 insulation board, wood deck, suspended acoustical ceiling | 18. Membrane, sheathing, R-15 insulation board, 8 in. HW concrete |
| 9. Membrane, sheathing, R-10 insulation board, metal deck | 19. Membrane, 6-in HW concrete, R-19 batt insulation, suspended acoustical ceiling |
| 10. Membrane, sheathing, R-10 insulation board, metal deck, suspended acoustical ceiling | |

indoor design condition), where the positive soil-to-indoor temperature difference causes sensible heat gains (Rock 2005). In many climates and for various temperatures and local soil conditions, moisture transport up through slabs-on-grade and basement floors is also significant, and contributes to the latent heat portion of the cooling load.

CALCULATING COOLING LOAD

The **instantaneous cooling load** is the rate at which heat energy is convected to the zone air at a given point in time. Computation of cooling load is complicated by the radiant exchange between

surfaces, furniture, partitions, and other mass in the zone. Most heat gain sources transfer energy by both convection and radiation. Radiative heat transfer introduces a time dependency to the process that is not easily quantified. Radiation is absorbed by thermal masses in the zone and then later transferred by convection into the space. This process creates a time lag and dampening effect. The convective portion, on the other hand, is assumed to immediately become cooling load in the hour in which that heat gain occurs.

Heat balance procedures calculate the radiant exchange between surfaces based on their surface temperatures and emissivities, but they typically rely on estimated “radiative/convective splits” to determine the contribution of internal loads, including people, lighting,

Table 18 Thermal Properties and Code Numbers of Layers Used in Wall and Roof Descriptions for Tables 16 and 17

Layer ID	Description	Thickness, in.	Conductivity, Btu·in/h·ft ² ·°F	Density, lb/ft ³	Specific Heat, Btu/lb·°F	Resistance, ft ² ·°F·h/Btu	R	Mass, lb/ft ²	Thermal Capacity, Btu/ft ² ·°F	Notes
F01	Outside surface resistance	—	—	—	—	0.25	0.25	—	—	1
F02	Inside vertical surface resistance	—	—	—	—	0.68	0.68	—	—	2
F03	Inside horizontal surface resistance	—	—	—	—	0.92	0.92	—	—	3
F04	Wall air space resistance	—	—	—	—	0.87	0.87	—	—	4
F05	Ceiling air space resistance	—	—	—	—	1.00	1.00	—	—	5
F06	EIFS finish	0.375	5.00	116.0	0.20	—	0.08	3.63	0.73	6
F07	1 in. stucco	1.000	5.00	116.0	0.20	—	0.20	9.67	1.93	6
F08	Metal surface	0.030	314.00	489.0	0.12	—	0.00	1.22	0.15	7
F09	Opaque spandrel glass	0.250	6.90	158.0	0.21	—	0.04	3.29	0.69	8
F10	1 in. stone	1.000	22.00	160.0	0.19	—	0.05	13.33	2.53	9
F11	Wood siding	0.500	0.62	37.0	0.28	—	0.81	1.54	0.43	10
F12	Asphalt shingles	0.125	0.28	70.0	0.30	—	0.44	0.73	0.22	
F13	Built-up roofing	0.375	1.13	70.0	0.35	—	0.33	2.19	0.77	
F14	Slate or tile	0.500	11.00	120.0	0.30	—	0.05	5.00	1.50	
F15	Wood shingles	0.250	0.27	37.0	0.31	—	0.94	0.77	0.24	
F16	Acoustic tile	0.750	0.42	23.0	0.14	—	1.79	1.44	0.20	11
F17	Carpet	0.500	0.41	18.0	0.33	—	1.23	0.75	0.25	12
F18	Terrazzo	1.000	12.50	160.0	0.19	—	0.08	13.33	2.53	13
G01	5/8 in. gyp board	0.625	1.11	50.0	0.26	—	0.56	2.60	0.68	
G02	5/8 in. plywood	0.625	0.80	34.0	0.29	—	0.78	1.77	0.51	
G03	1/2 in. fiberboard sheathing	0.500	0.47	25.0	0.31	—	1.06	1.04	0.32	14
G04	1/2 in. wood	0.500	1.06	38.0	0.39	—	0.47	1.58	0.62	15
G05	1 in. wood	1.000	1.06	38.0	0.39	—	0.94	3.17	1.24	15
G06	2 in. wood	2.000	1.06	38.0	0.39	—	1.89	6.33	2.47	15
G07	4 in. wood	4.000	1.06	38.0	0.39	—	3.77	12.67	4.94	15
I01	R-5, 1 in. insulation board	1.000	0.20	2.7	0.29	—	5.00	0.23	0.07	16
I02	R-10, 2 in. insulation board	2.000	0.20	2.7	0.29	—	10.00	0.45	0.13	16
I03	R-15, 3 in. insulation board	3.000	0.20	2.7	0.29	—	15.00	0.68	0.20	16
I04	R-11, 3-1/2 in. batt insulation	3.520	0.32	1.2	0.23	—	11.00	0.35	0.08	17
I05	R-19, 6-1/4 in. batt insulation	6.080	0.32	1.2	0.23	—	19.00	0.61	0.14	17
I06	R-30, 9-1/2 in. batt insulation	9.600	0.32	1.2	0.23	—	30.00	0.96	0.22	17
M01	4 in. brick	4.000	6.20	120.0	0.19	—	0.65	40.00	7.60	18
M02	6 in. LW concrete block	6.000	3.39	32.0	0.21	—	1.77	16.00	3.36	19
M03	8 in. LW concrete block	8.000	3.44	29.0	0.21	—	2.33	19.33	4.06	20
M04	12 in. LW concrete block	12.000	4.92	32.0	0.21	—	2.44	32.00	6.72	21
M05	8 in. concrete block	8.000	7.72	50.0	0.22	—	1.04	33.33	7.33	22
M06	12 in. concrete block	12.000	9.72	50.0	0.22	—	1.23	50.00	11.00	23
M07	6 in. LW concrete block (filled)	6.000	1.98	32.0	0.21	—	3.03	16.00	3.36	24
M08	8 in. LW concrete block (filled)	8.000	1.80	29.0	0.21	—	4.44	19.33	4.06	25
M09	12 in. LW concrete block (filled)	12.000	2.04	32.0	0.21	—	5.88	32.00	6.72	26
M10	8 in. concrete block (filled)	8.000	5.00	50.0	0.22	—	1.60	33.33	7.33	27
M11	4 in. lightweight concrete	4.000	3.70	80.0	0.20	—	1.08	26.67	5.33	
M12	6 in. lightweight concrete	6.000	3.70	80.0	0.20	—	1.62	40.00	8.00	
M13	8 in. lightweight concrete	8.000	3.70	80.0	0.20	—	2.16	53.33	10.67	
M14	6 in. heavyweight concrete	6.000	13.50	140.0	0.22	—	0.44	70.00	15.05	
M15	8 in. heavyweight concrete	8.000	13.50	140.0	0.22	—	0.48	93.33	20.07	
M16	12 in. heavyweight concrete	12.000	13.50	140.0	0.22	—	0.89	140.0	30.10	
M17	2 in. LW concrete roof ballast	2.000	1.30	40	0.20	—	1.54	6.7	1.33	28

Notes: The following notes give sources for the data in this table.

- Chapter 26, Table 1 for 7.5 mph wind
- Chapter 26, Table 1 for still air, horizontal heat flow
- Chapter 26, Table 1 for still air, downward heat flow
- Chapter 26, Table 3 for 1.5 in. space, 90°F, horizontal heat flow, 0.82 emittance
- Chapter 26, Table 3 for 3.5 in. space, 90°F, downward heat flow, 0.82 emittance
- EIFS finish layers approximated by Chapter 26, Table 4 for 3/8 in. cement plaster, sand aggregate
- Chapter 33, Table 3 for steel (mild)
- Chapter 26, Table 4 for architectural glass
- Chapter 26, Table 4 for marble and granite
- Chapter 26, Table 4, density assumed same as Southern pine
- Chapter 26, Table 4 for mineral fiberboard, wet molded, acoustical tile
- Chapter 26, Table 4 for carpet and rubber pad, density assumed same as fiberboard
- Chapter 26, Table 4, density assumed same as stone

- Chapter 26, Table 4 for nail-base sheathing
- Chapter 26, Table 4 for Southern pine
- Chapter 26, Table 4 for expanded polystyrene
- Chapter 26, Table 4 for glass fiber batt, specific heat per glass fiber board
- Chapter 26, Table 4 for clay fired brick
- Chapter 26, Table 4, 16 lb block, 8 × 16 in. face
- Chapter 26, Table 4, 19 lb block, 8 × 16 in. face
- Chapter 26, Table 4, 32 lb block, 8 × 16 in. face
- Chapter 26, Table 4, 33 lb normal weight block, 8 × 16 in. face
- Chapter 26, Table 4, 50 lb normal weight block, 8 × 16 in. face
- Chapter 26, Table 4, 16 lb block, vermiculite fill
- Chapter 26, Table 4, 19 lb block, 8 × 16 in. face, vermiculite fill
- Chapter 26, Table 4, 32 lb block, 8 × 16 in. face, vermiculite fill
- Chapter 26, Table 4, 33 lb normal weight block, 8 × 16 in. face, vermiculite fill
- Chapter 26, Table 4 for 40 lb/ft³ LW concrete

appliances, and equipment, to the radiant exchange. RTS further simplifies the HB procedure by also relying on an estimated radiative/convective split of wall and roof conductive heat gain instead of simultaneously solving for the instantaneous convective and radiative heat transfer from each surface, as is done in the HB procedure.

Thus, the cooling load for each load component (lights, people, walls, roofs, windows, appliances, etc.) for a particular hour is the sum of the convective portion of the heat gain for that hour plus the time-delayed portion of radiant heat gains for that hour and the previous 23 h. Table 14 contains recommendations for splitting each of the heat gain components into convective and radiant portions.

RTS converts the radiant portion of hourly heat gains to hourly cooling loads using radiant time factors, the coefficients of the radiant time series. Radiant time factors are used to calculate the cooling load for the current hour on the basis of current and past heat gains. The radiant time series for a particular zone gives the time-dependent response of the zone to a single pulse of radiant energy. The series shows the portion of the radiant pulse that is convected to zone air for each hour. Thus, r_0 represents the fraction of the radiant pulse convected to the zone air in the current hour r_1 in the previous hour, and so on. The radiant time series thus generated is used to convert the radiant portion of hourly heat gains to hourly cooling loads according to the following equation:

$$Q_{r,\theta} = r_0 q_{r,\theta} + r_1 q_{r,\theta-1} + r_2 q_{r,\theta-2} + r_3 q_{r,\theta-3} + \dots + r_{23} q_{r,\theta-23} \quad (34)$$

where

$Q_{r,\theta}$ =radiant cooling load Q_r for current hour θ , Btu/h

$q_{r,\theta}$ =radiant heat gain for current hour, Btu/h

$q_{r,\theta-n}$ =radiant heat gain n hours ago, Btu/h

r_0, r_1, \dots =radiant time factors

The radiant cooling load for the current hour, which is calculated using RTS and Equation (34), is added to the convective portion to determine the total cooling load for that component for that hour.

Radiant time factors are generated by a heat balance based procedure. A separate series of radiant time factors is theoretically required for each unique zone and for each unique radiant energy distribution function assumption. For most common design applications, RTS variation depends primarily on the overall massiveness of the construction and the thermal responsiveness of the surfaces the radiant heat gains strike.

One goal in developing RTS was to provide a simplified method based directly on the HB method; thus, it was deemed desirable to generate RTS coefficients directly from a heat balance. A heat balance computer program was developed to do this: Hbfort, which is included as part of *Cooling and Heating Load Calculation Principles* (Pedersen et al. 1998). The RTS procedure is described by Spitler et al. (1997). The procedure for generating RTS coefficients may be thought of as analogous to the custom weighting factor generation procedure used by DOE 2.1 (Kerrisk et al. 1981; Sowell 1988a, 1988b). In both cases, a zone model is pulsed with a heat gain. With DOE 2.1, the resulting loads are used to estimate the best values of the transfer function method weighting factors to most closely match the load profile. In the procedure described here, a unit periodic heat gain pulse is used to generate loads for a 24 h period. As long as the heat gain pulse is a unit pulse, the resulting loads are equivalent to the RTS coefficients.

Two different radiant time series are used: **Solar**, for direct transmitted solar heat gain (radiant energy assumed to be distributed to the floor and furnishings only) and **nonsolar**, for all other types of heat gains (radiant energy assumed to be uniformly distributed on all internal surfaces). Nonsolar RTS apply to radiant heat gains from people, lights, appliances, walls, roofs, and floors. Also, for diffuse solar heat gain and direct solar heat gain from fenestration with inside shading (blinds, drapes, etc.), the nonsolar RTS should be used. Radiation from those sources is assumed to be more uniformly

distributed onto all room surfaces. Effect of beam solar radiation distribution assumptions is addressed by Hittle (1999).

Representative solar and nonsolar RTS data for light, medium, and heavyweight constructions are provided in Tables 19 and 20. Those were calculated using the Hbfort computer program (Pedersen et al. 1998) with zone characteristics listed in Table 21. Customized RTS values may be calculated using the HB method where the zone is not reasonably similar to these typical zones or where more precision is desired.

ASHRAE research project RP-942 compared HB and RTS results over a wide range of zone types and input variables (Rees et al. 2000; Spitler et al. 1998). In general, total cooling loads calculated using RTS closely agreed with or were slightly higher than those of the HB method with the same inputs. The project examined more than 5000 test cases of varying zone parameters. The dominating variable was overall thermal mass, and results were grouped into lightweight, U.S. medium-weight, U.K. medium-weight, and heavyweight construction. Best agreement between RTS and HB results was obtained for light- and medium-weight construction. Greater differences occurred in heavyweight cases, with RTS generally predicting slightly higher peak cooling loads than HB. Greater differences also were observed in zones with extremely high internal radiant loads and large glazing areas or with a very lightweight exterior envelope. In this case, heat balance calculations predict that some of the internal radiant load will be transmitted to the outdoor environment and never becomes cooling load within the space. RTS does not account for energy transfer out of the space to the environment, and thus predicted higher cooling loads.

ASHRAE research project RP-1117 constructed two model rooms for which cooling loads were physically measured using extensive instrumentation. The results agreed with previous simulations (Chantrasrisalai et al. 2003; Eldridge et al. 2003; Iu et al. 2003). HB calculations closely approximated the measured cooling loads when provided with detailed data for the test rooms. RTS overpredicted measured cooling loads in tests with large, clear, single-glazed window areas with bare concrete floor and no furnishings or internal loads. Tests under more typical conditions (venetian blinds, carpeted floor, office-type furnishings, and normal internal loads) provided good agreement between HB, RTS, and measured loads.

HEATING LOAD CALCULATIONS

Techniques for estimating design heating load for commercial, institutional, and industrial applications are essentially the same as for those estimating design cooling loads for such uses, with the following exceptions:

- Temperatures outside conditioned spaces are generally lower than maintained space temperatures.
- Credit for solar or internal heat gains is not included
- Thermal storage effect of building structure or content is ignored.
- Thermal bridging effects on wall and roof conduction are greater for heating loads than for cooling loads, and greater care must be taken to account for bridging effects on U-factors used in heating load calculations.

Heat losses (negative heat gains) are thus considered to be instantaneous, heat transfer essentially conductive, and latent heat treated only as a function of replacing space humidity lost to the exterior environment.

This simplified approach is justified because it evaluates worst-case conditions that can reasonably occur during a heating season. Therefore, the near-worst-case load is based on the following:

- Design interior and exterior conditions
- Including infiltration and/or ventilation
- No solar effect (at night or on cloudy winter days)
- Before the periodic presence of people, lights, and appliances has an offsetting effect

Table 19 Representative Nonsolar RTS Values for Light to Heavy Construction

% Glass	Interior Zones																										
	Light						Medium						Heavy						Light			Medium			Heavy		
	With Carpet			No Carpet			With Carpet			No Carpet			With Carpet			No Carpet			With Carpet	No Carpet	With Carpet	No Carpet	With Carpet	No Carpet	With Carpet	No Carpet	
	10%	50%	90%	10%	50%	90%	10%	50%	90%	10%	50%	90%	10%	50%	90%	10%	50%	90%	10%	50%	90%	10%	50%	90%	10%	50%	90%
Hour	Radiant Time Factor, %																										
0	47	50	53	41	43	46	46	49	52	31	33	35	34	38	42	22	25	28	46	40	46	31	33	21			
1	19	18	17	20	19	19	18	17	16	17	16	15	9	9	9	10	9	9	19	20	18	17	9	9			
2	11	10	9	12	11	11	10	9	8	11	10	10	6	6	5	6	6	6	11	12	10	11	6	6			
3	6	6	5	8	7	7	6	5	5	8	7	7	4	4	4	5	5	5	6	8	6	8	5	5			
4	4	4	3	5	5	5	4	3	3	6	5	5	4	4	4	5	5	4	4	5	3	6	4	5			
5	3	3	2	4	3	3	2	2	2	4	4	4	4	3	3	4	4	4	3	4	2	4	4	4			
6	2	2	2	3	3	2	2	2	2	4	3	3	3	3	3	4	4	4	2	3	2	4	3	4			
7	2	1	1	2	2	2	1	1	1	3	3	3	3	3	3	4	4	4	2	2	1	3	3	4			
8	1	1	1	1	1	1	1	1	1	3	2	2	3	3	3	4	3	3	1	1	1	3	3	4			
9	1	1	1	1	1	1	1	1	1	2	2	2	3	3	2	3	3	3	1	1	1	2	3	3			
10	1	1	1	1	1	1	1	1	1	2	2	2	3	2	2	3	3	3	1	1	1	2	3	3			
11	1	1	1	1	1	1	1	1	1	2	2	2	2	2	2	3	3	3	1	1	1	2	2	3			
12	1	1	1	1	1	1	1	1	1	1	1	1	2	2	2	3	3	3	1	1	1	1	2	3			
13	1	1	1	0	1	0	1	1	1	1	1	1	2	2	2	3	3	2	1	1	1	1	2	3			
14	0	0	1	0	1	0	1	1	1	1	1	1	2	2	2	3	2	2	1	0	1	1	2	3			
15	0	0	1	0	0	0	1	1	1	1	1	1	2	2	2	2	2	2	0	0	1	1	2	3			
16	0	0	0	0	0	0	1	1	1	1	1	1	2	2	2	2	2	2	0	0	1	1	2	3			
17	0	0	0	0	0	0	1	1	1	1	1	1	2	2	2	2	2	2	0	0	1	1	2	2			
18	0	0	0	0	0	0	1	1	1	1	1	1	2	2	1	2	2	2	0	0	1	1	2	2			
19	0	0	0	0	0	0	0	1	0	0	1	1	2	2	1	2	2	2	0	0	1	0	2	2			
20	0	0	0	0	0	0	0	0	0	0	1	1	2	1	1	2	2	2	0	0	0	0	2	2			
21	0	0	0	0	0	0	0	0	0	0	1	1	2	1	1	2	2	2	0	0	0	0	2	2			
22	0	0	0	0	0	0	0	0	0	0	1	0	1	1	1	2	2	2	0	0	0	0	1	2			
23	0	0	0	0	0	0	0	0	0	0	0	0	1	1	1	2	2	1	0	0	0	0	1	2			
	100	100	100	100	100	100	100	100	100	100	100	100	100	100	100	100	100	100	100	100	100	100	100	100			

Table 20 Representative Solar RTS Values for Light to Heavy Construction

% Glass	Interior Zones																	
	Light						Medium						Heavy					
	With Carpet			No Carpet			With Carpet			No Carpet			With Carpet			No Carpet		
	10%	50%	90%	10%	50%	90%	10%	50%	90%	10%	50%	90%	10%	50%	90%	10%	50%	90%
Hour	Radiant Time Factor, %																	
0	53	55	56	44	45	46	52	54	55	28	29	29	47	49	51	26	27	28
1	17	17	17	19	20	20	16	16	15	15	15	15	11	12	12	12	13	13
2	9	9	9	11	11	11	8	8	8	10	10	10	6	6	6	7	7	7
3	5	5	5	7	7	7	5	4	4	7	7	7	4	4	3	5	5	5
4	3	3	3	5	5	5	3	3	3	6	6	6	3	3	3	4	4	4
5	2	2	2	3	3	3	2	2	2	5	5	5	2	2	2	4	4	4
6	2	2	2	3	2	2	2	1	1	4	4	4	2	2	2	3	3	3
7	1	1	1	2	2	2	1	1	1	4	3	3	2	2	2	3	3	3
8	1	1	1	1	1	1	1	1	1	3	3	3	2	2	2	3	3	3
9	1	1	1	1	1	1	1	1	1	3	3	3	2	2	2	3	3	3
10	1	1	1	1	1	1	1	1	1	2	2	2	2	2	2	3	3	3
11	1	1	1	1	1	1	1	1	1	2	2	2	2	2	1	3	3	2
12	1	1	1	1	1	0	1	1	1	2	2	2	2	1	1	2	2	2
13	1	1	0	1	0	0	1	1	1	2	2	2	2	1	1	2	2	2
14	1	0	0	0	0	0	1	1	1	1	1	1	2	1	1	2	2	2
15	1	0	0	0	0	0	1	1	1	1	1	1	1	1	1	2	2	2
16	0	0	0	0	0	0	1	1	1	1	1	1	1	1	1	2	2	2
17	0	0	0	0	0	0	1	1	1	1	1	1	1	1	1	2	2	2
18	0	0	0	0	0	0	1	1	1	1	1	1	1	1	1	2	2	2
19	0	0	0	0	0	0	0	0	0	1	1	1	1	1	1	2	2	2
20	0	0	0	0	0	0	0	0	0	1	1	1	1	1	1	2	2	2
21	0	0	0	0	0	0	0	0	0	0	0	0	1	1	1	2	2	2
22	0	0	0	0	0	0	0	0	0	0	0	0	1	1	1	2	1	1
23	0	0	0	0	0	0	0	0	0	0	0	0	1	1	1	2	1	1
	100	100	100	100	100	100	100	100	100	100	100	100	100	100	100	100	100	100

Table 21 RTS Representative Zone Construction for Tables 19 and 20

Construction Class	Exterior Wall	Roof/Ceiling	Partitions	Floor	Furnishings
Light	steel siding, 2 in. insulation, air space, 3/4 in. gyp	4 in. LW concrete, ceiling air space, acoustic tile	3/4 in. gyp, air space, 3/4 in. gyp	acoustic tile, ceiling air space, 4 in. LW concrete	1 in. wood @ 50% of floor area
Medium	4 in. face brick, 2 in. insulation, air space, 3/4 in. gyp	4 in. HW concrete, ceiling air space, acoustic tile	3/4 in. gyp, air space, 3/4 in. gyp	acoustic tile, ceiling air space, 4 in. HW concrete	1 in. wood @ 50% of floor area
Heavy	4 in. face brick, 8 in. HW concrete air space, 2 in. insulation, 3/4 in. gyp	8 in. HW concrete, ceiling air space, acoustic tile	3/4 in. gyp, 8 in. HW concrete block, 3/4 in. gyp	acoustic tile, ceiling air space, 8 in. HW concrete	1 in. wood @ 50% of floor area

Typical commercial and retail spaces have nighttime unoccupied periods at a setback temperature where little to no ventilation is required, building lights and equipment are off, and heat loss is primarily through conduction and infiltration. Before being occupied, buildings are warmed to the occupied temperature (see the following discussion). During occupied time, building lights, equipment, and people cooling loads can offset conduction heat loss, although some perimeter heat may be required, leaving the infiltration and ventilation loads as the primary heating loads. Ventilation heat load may be offset with heat recovery equipment. These loads (conduction loss, warm-up load, and ventilation load) may not be additive when sizing building heating equipment, and it is prudent to analyze each load and their interactions to arrive at final equipment sizing for heating.

HEAT LOSS CALCULATIONS

The general procedure for calculation of design heat losses of a structure is as follows:

1. Select outdoor design conditions: temperature, humidity, and wind direction and speed.
2. Select indoor design conditions to be maintained.
3. Estimate temperature in any adjacent unheated spaces.
4. Select transmission coefficients and compute heat losses for walls, floors, ceilings, windows, doors, and foundation elements.
5. Compute heat load through infiltration and any other outdoor air introduced directly to the space.
6. Sum the losses caused by transmission and infiltration.

Outdoor Design Conditions

The ideal heating system would provide enough heat to match the structure's heat loss. However, weather conditions vary considerably from year to year, and heating systems designed for the worst weather conditions on record would have a great excess of capacity most of the time. A system's failure to maintain design conditions during brief periods of severe weather usually is not critical. However, close regulation of indoor temperature may be critical for some occupancies or industrial processes. Design temperature data and discussion of their application are given in Chapter 14. Generally, the 99% temperature values given in the tabulated weather data be used. However, caution should be used, and local conditions always investigated. In some locations, outdoor temperatures are commonly much lower and wind velocities higher than those given in the tabulated weather data.

Indoor Design Conditions

The main purpose of the heating system is to maintain indoor conditions that make most of the occupants comfortable. It should be kept in mind, however, that the purpose of heating load calculations is to obtain data for sizing the heating system components. In many cases, the system will rarely be called upon to operate at the design conditions. Therefore, the use and occupancy of the space are general considerations from the design temperature point of view. Later, when the building's energy requirements are computed, the actual conditions in the space and outdoor environment, including internal heat gains, must be considered.

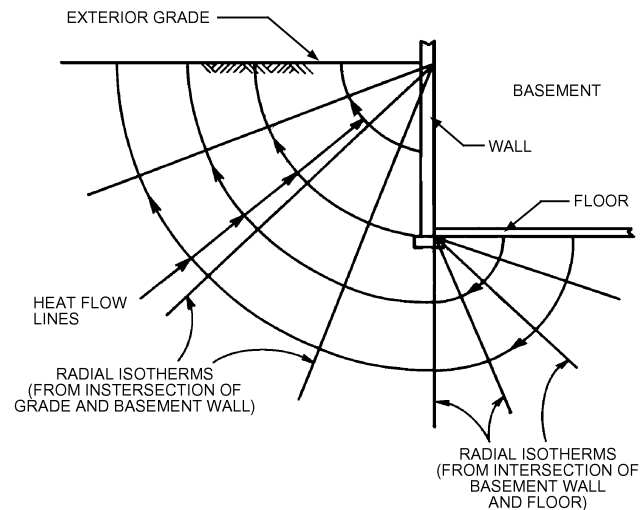

Fig. 12 Heat Flow from Below-Grade Surface

The indoor design temperature should be selected at the lower end of the acceptable temperature range, so that the heating equipment will not be oversized. Even properly sized equipment operates under partial load, at reduced efficiency, most of the time; therefore, any oversizing aggravates this condition and lowers overall system efficiency. A maximum design dry-bulb temperature of 70°F is recommended for most occupancies. The indoor design value of relative humidity should be compatible with a healthful environment and the thermal and moisture integrity of the building envelope. A minimum relative humidity of 30% is recommended for most situations.

Calculation of Transmission Heat Losses

Exterior Surface Above Grade. All above-grade surfaces exposed to outdoor conditions (walls, doors, ceilings, fenestration, and raised floors) are treated identically, as follows:

$$q = A \times \text{HF} \quad (35)$$

$$\text{HF} = U \Delta t \quad (36)$$

where HF is the heating load factor in Btu/h·ft².

Below-Grade Surfaces. An approximate method for estimating below-grade heat loss [based on the work of Latta and Boileau (1969)] assumes that the heat flow paths shown in Figure 12 can be used to find the steady-state heat loss to the ground surface, as follows:

$$\text{HF} = U_{\text{avg}}(t_{\text{in}} - t_{\text{gr}}) \quad (37)$$

where

U_{avg} = average U-factor for below-grade surface from Equation (39) or (40), Btu/h·ft²·°F

t_{in} = below-grade space air temperature, °F

t_{gr} = design ground surface temperature from Equation (38), °F

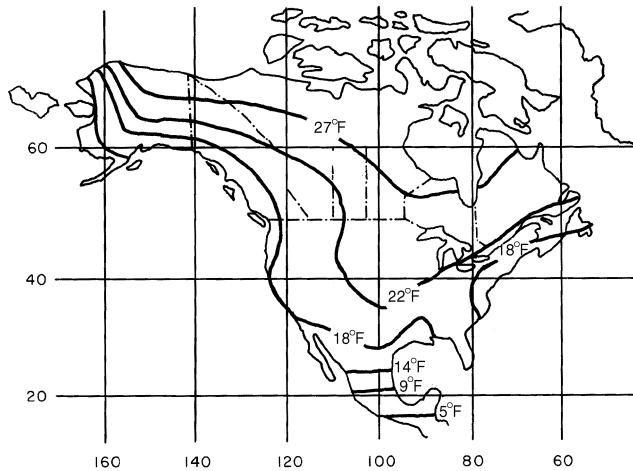

Fig. 13 Ground Temperature Amplitude

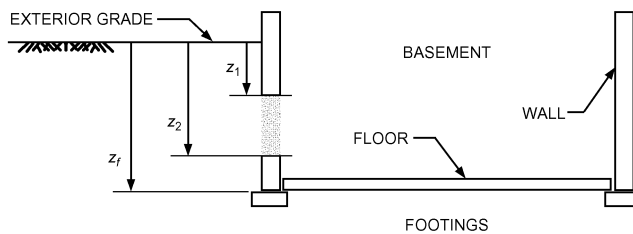

Fig. 14 Below-Grade Parameters

The effect of soil heat capacity means that none of the usual external design air temperatures are suitable values for t_{gr} . Ground surface temperature fluctuates about an annual mean value by amplitude A , which varies with geographic location and surface cover. The minimum ground surface temperature, suitable for heat loss estimates, is therefore

$$t_{gr} = \bar{t}_{gr} - A \quad (38)$$

where

\bar{t}_{gr} = mean ground temperature, °F, estimated from the annual average air temperature or from well-water temperatures, shown in Figure 17 of Chapter 32 in the 2007 ASHRAE Handbook—HVAC Applications

A = ground surface temperature amplitude, °F, from Figure 13 for North America

Figure 14 shows depth parameters used in determining U_{avg} . For walls, the region defined by z_1 and z_2 may be the entire wall or any portion of it, allowing partially insulated configurations to be analyzed piecewise.

The below-grade wall average U-factor is given by

$$U_{avg,bw} = \frac{2k_{soil}}{\pi(z_1 - z_2)} \times \left[\ln \left(z_2 + \frac{2k_{soil}R_{other}}{\pi} \right) - \ln \left(z_1 + \frac{2k_{soil}R_{other}}{\pi} \right) \right] \quad (39)$$

where

$U_{avg,bw}$ = average U-factor for wall region defined by z_1 and z_2 , Btu/h·ft²·°F

k_{soil} = soil thermal conductivity, Btu/h·ft·°F

R_{other} = total resistance of wall, insulation, and inside surface resistance, h·ft²·°F/Btu

z_1, z_2 = depths of top and bottom of wall segment under consideration, ft (Figure 14)

Table 22 Average U-Factor for Basement Walls with Uniform Insulation

Depth, ft	$U_{avg,bw}$ from Grade to Depth, Btu/h·ft ² ·°F			
	Uninsulated	R-5	R-10	R-15
1	0.432	0.135	0.080	0.057
2.6	0.331	0.121	0.075	0.054
3	0.273	0.110	0.070	0.052
4	0.235	0.101	0.066	0.050
5	0.208	0.094	0.063	0.048
6	0.187	0.088	0.060	0.046
7	0.170	0.083	0.057	0.044
8	0.157	0.078	0.055	0.043

Soil conductivity = 0.8 Btu/h·ft·°F; insulation is over entire depth. For other soil conductivities and partial insulation, use Equation (39).

Table 23 Average U-Factor for Basement Floors

z_f (Depth of Floor Below Grade), ft	$U_{avg,bf}$, Btu/h·ft ² ·°F			
	w_b (Shortest Width of Basement), ft			
	20	24	28	32
1	0.064	0.057	0.052	0.047
2	0.054	0.048	0.044	0.040
3	0.047	0.042	0.039	0.036
4	0.042	0.038	0.035	0.033
5	0.038	0.035	0.032	0.030
6	0.035	0.032	0.030	0.028
7	0.032	0.030	0.028	0.026

Soil conductivity is 0.8 Btu/h·ft·°F; floor is uninsulated. For other soil conductivities and insulation, use Equation (39).

The value of soil thermal conductivity k varies widely with soil type and moisture content. A typical value of 0.8 Btu/h·ft·°F has been used previously to tabulate U-factors, and R_{other} is approximately 1.47 h·ft²·°F/Btu for uninsulated concrete walls. For these parameters, representative values for $U_{avg,bw}$ are shown in Table 22.

The average below-grade floor U-factor (where the entire basement floor is uninsulated or has uniform insulation) is given by

$$U_{avg,bf} = \frac{2k_{soil}}{\pi w_b} \times \left[\ln \left(\frac{w_b}{2} + \frac{z_f}{2} + \frac{k_{soil}R_{other}}{\pi} \right) - \ln \left(\frac{k_{soil}R_{other}}{\pi} \right) \right] \quad (40)$$

where

w_b = basement width (shortest dimension), ft

z_f = floor depth below grade, ft (see Figure 14)

Representative values of $U_{avg,bf}$ for uninsulated basement floors are shown in Table 23.

At-Grade Surfaces. Concrete slab floors may be (1) unheated, relying for warmth on heat delivered above floor level by the heating system, or (2) heated, containing heated pipes or ducts that constitute a radiant slab or portion of it for complete or partial heating of the house.

The simplified approach that treats heat loss as proportional to slab perimeter allows slab heat loss to be estimated for both unheated and heated slab floors:

$$q = p \times HF \quad (41)$$

$$HF = F_p \Delta t \quad (42)$$

where

q = heat loss through perimeter, Btu/h

F_p = heat loss coefficient per foot of perimeter, Btu/h·ft·°F, Table 24

p = perimeter (exposed edge) of floor, ft

Table 24 Heat Loss Coefficient F_p of Slab Floor Construction

Construction	Insulation	F_p , Btu/h·ft·°F
8 in. block wall, brick facing	Uninsulated	0.68
	R-5.4 from edge to footer	0.50
4 in. block wall, brick facing	Uninsulated	0.84
	R-5.4 from edge to footer	0.49
Metal stud wall, stucco	Uninsulated	1.20
	R-5.4 from edge to footer	0.53
Poured concrete wall with duct near perimeter*	Uninsulated	2.12
	R-5.4 from edge to footer	0.72

*Weighted average temperature of heating duct was assumed at 110°F during heating season (outdoor air temperature less than 65°F).

Surfaces Adjacent to Buffer Space. Heat loss to adjacent unconditioned or semiconditioned spaces can be calculated using a heating factor based on the partition temperature difference:

$$HF = U(t_{in} - t_b) \quad (43)$$

Infiltration

All structures have some air leakage or infiltration. This means a heat loss because the cold, dry outdoor air must be heated to the inside design temperature and moisture must be added to increase the humidity to the design value. Procedures for estimating the infiltration rate are discussed in [Chapter 16](#).

Once the infiltration rate has been calculated, the resulting sensible heat loss, equivalent to the sensible heating load from infiltration, is given by

$$q_s = 60(\text{cfm}/v) c_p(t_{in} - t_o) \quad (44)$$

where

- cfm = volume flow rate of infiltrating air
- c_p = specific heat capacity of air, Btu/lb_m·°F
- v = specific volume of infiltrating air, ft³/lb_m

Assuming standard air conditions (59°F and sea-level conditions) for v and c_p , Equation (44) may be written as

$$q_s = 1.10(\text{cfm})(t_{in} - t_o) \quad (45)$$

The infiltrating air also introduces a latent heating load given by

$$q_l = 60(\text{cfm}/v)(W_{in} - W_o)D_h \quad (46)$$

where

- W_{in} = humidity ratio for inside space air, lb_w/lb_a
- W_o = humidity ratio for outdoor air, lb_w/lb_a
- D_h = change in enthalpy to convert 1 lb water from vapor to liquid, Btu/lb_w

For standard air and nominal indoor comfort conditions, the latent load may be expressed as

$$q_l = 4840(\text{cfm})(W_{in} - W_o) \quad (47)$$

The coefficients 1.10 in Equation (45) and 4840 in Equation (47) are given for standard conditions. They depend on temperature and altitude (and, consequently, pressure).

HEATING SAFETY FACTORS AND LOAD ALLOWANCES

Before mechanical cooling became common in the second half of the 1900s, and when energy was less expensive, buildings included much less insulation; large, operable windows; and generally more

Table 25 Common Sizing Calculations in Other Chapters

Subject	Volume/Chapter	Equation(s)
Duct heat transfer	ASTM <i>Standard</i> C680	
Piping heat transfer	Fundamentals Ch. 3	(35)
Fan heat transfer	Fundamentals Ch. 19	(22)
Pump heat transfer	Systems Ch. 43	(3), (4), (5)
Moist-air sensible heating and cooling	Fundamentals Ch. 1	(43)
Moist-air cooling and dehumidification	Fundamentals Ch. 1	(45)
Air mixing	Fundamentals Ch. 1	(46)
Space heat absorption and moist-air moisture gains	Fundamentals Ch. 1	(48)
Adiabatic mixing of water injected into moist air	Fundamentals Ch. 1	(47)

infiltration-prone assemblies than the energy-efficient and much tighter buildings typical of today. Allowances of 10 to 20% of the net calculated heating load for piping losses to unheated spaces, and 10 to 20% more for a warm-up load, were common practice, along with other occasional safety factors reflecting the experience and/or concern of the individual designer. Such measures are less conservatively applied today with newer construction. A combined warm-up/safety allowance of 20 to 25% is fairly common but varies depending on the particular climate, building use, and type of construction. Engineering judgment must be applied for the particular project. Armstrong et al. (1992a, 1992b) provide a design method to deal with warm-up and cooldown load.

OTHER HEATING CONSIDERATIONS

Calculation of design heating load estimates has essentially become a subset of the more involved and complex estimation of cooling loads for such spaces. [Chapter 19](#) discusses using the heating load estimate to predict or analyze energy consumption over time. Special provisions to deal with particular applications are covered in the 2007 *ASHRAE Handbook—HVAC Applications* and the 2008 *ASHRAE Handbook—HVAC Systems and Equipment*.

The 1989 *ASHRAE Handbook—Fundamentals* was the last edition to contain a chapter dedicated only to heating load. Its contents were incorporated into this volume's [Chapter 17](#), which describes steady-state conduction and convection heat transfer and provides, among other data, information on losses through basement floors and slabs.

SYSTEM HEATING AND COOLING LOAD EFFECTS

The heat balance (HB) or radiant time series (RTS) methods are used to determine cooling loads of rooms within a building, but they do not address the plant size necessary to reject the heat. Principal factors to consider in determining the plant size are ventilation, heat transport equipment, and air distribution systems. Some of these factors vary as a function of room load, ambient temperature, and control strategies, so it is often necessary to evaluate the factors and strategies dynamically and simultaneously with the heat loss or gain calculations.

The detailed analysis of system components and methods calculating their contribution to equipment sizing are beyond the scope of this chapter, which is general in nature. [Table 25](#) lists the most frequently used calculations in other chapters and volumes.

ZONING

The organization of building rooms as defined for load calculations into zones and air-handling units has no effect on room cooling loads. However, specific grouping and ungrouping of rooms into

zones may cause peak system loads to occur at different times during the day or year and may significantly affected heat removal equipment sizes.

For example, if each room is cooled by a separate heat removal system, the total capacity of the heat transport systems equals the sum of peak room loads. Conditioning all rooms by a single heat transport system (e.g., a variable-volume air handler) requires less capacity (equal to the simultaneous peak of the combined rooms load, which includes some rooms at off-peak loads). This may significantly reduce equipment capacity, depending on the configuration of the building.

VENTILATION

Consult ASHRAE *Standard* 62.1 and building codes to determine the required quantity of ventilation air for an application, and the various methods of achieving acceptable indoor air quality. The following discussion is confined to the effect of mechanical ventilation on sizing heat removal equipment. Where natural ventilation is used, through operable windows or other means, it is considered as infiltration and is part of the direct-to-room heat gain. Where ventilation air is conditioned and supplied through the mechanical system its sensible and latent loads are applied directly to heat transport and central equipment, and do not affect room heating and cooling loads. If the mechanical ventilation rate sufficiently exceeds exhaust airflows, air pressure may be positive and infiltration from envelope openings and outside wind may not be included in the load calculations. **Chapter 16** includes more information on ventilating commercial buildings.

AIR HEAT TRANSPORT SYSTEMS

Heat transport equipment is usually selected to provide adequate heating or cooling for the peak load condition. However, selection must also consider maintaining desired inside conditions during all occupied hours, which requires matching the rate of heat transport to room peak heating and cooling loads. Automatic control systems normally vary the heating and cooling system capacity during these off-peak hours of operation.

On/Off Control Systems

On/off control systems, common in residential and light commercial applications, cycle equipment on and off to match room load. They are adaptable to heating or cooling because they can cycle both heating and cooling equipment. In their purest form, their heat transport matches the combined room and ventilation load over a series of cycles.

Variable-Air-Volume Systems

Variable-air-volume (VAV) systems have airflow controls that adjust cooling airflow to match the room cooling load. Damper leakage or minimum airflow settings may cause overcooling, so most VAV systems are used in conjunction with separate heating systems. These may be duct-mounted heating coils, or separate radiant or convective heating systems.

The amount of heat added by the heating systems during cooling becomes part of the room cooling load. Calculations must determine the minimum airflow relative to off-peak cooling loads. The quantity of heat added to the cooling load can be determined for each terminal by Equation (9) using the minimum required supply airflow rate and the difference between supply air temperature and the room inside heating design temperature.

Constant-Air-Volume Reheat Systems

In constant-air-volume (CAV) reheat systems, all supply air is cooled to remove moisture and then heated to avoid overcooling rooms. *Reheat* refers to the amount of heat added to cooling supply air to raise the supply air temperature to the temperature necessary

for picking up the sensible load. The quantity of heat added can be determined by Equation (9).

With a constant-volume reheat system, heat transport system load does not vary with changes in room load, unless the cooling coil discharge temperature is allowed to vary. Where a minimum circulation rate requires a supply air temperature greater than the available design supply air temperature, reheat adds to the cooling load on the heat transport system. This makes the cooling load on the heat transport system larger than the room peak load.

Mixed Air Systems

Mixed air systems change the supply air temperature to match the cooling capacity by mixing airstreams of different temperatures; examples include multizone and dual-duct systems. Systems that cool the entire airstream to remove moisture and to reheat some of the air before mixing with the cooling airstream influence load on the heat transport system in the same way a reheat system does. Other systems separate the air paths so that mixing of hot- and cold-deck airstreams does not occur. For systems that mix hot and cold airstreams, the contribution to the heat transport system load is determined as follows.

1. Determine the ratio of cold-deck flow to hot-deck flow from

$$\frac{Q_h}{Q_c} = (T_c - T_r) / (T_r - T_h)$$

2. From Equation (10), the hot-deck contribution to room load during off-peak cooling is

$$q_{rh} = 1.1Q_h (T_h - T_r)$$

where

- Q_h = heating airflow, cfm
- Q_c = cooling airflow, cfm
- T_c = cooling air temperature, °F
- T_h = heating air temperature, °F
- T_r = room or return air temperature, °F
- q_{rh} = heating airflow contribution to room load at off-peak hours, Btu/h

Heat Gain from Fans

Fans that circulate air through HVAC systems add energy to the system through the following processes:

- Increasing velocity and static pressure adds kinetic and potential energy
- Fan inefficiency in producing airflow and static pressure adds sensible heat (fan heat) to the airflow
- Inefficiency of motor and drive dissipates sensible heat

The power required to provide airflow and static pressure can be determined from the first law of thermodynamics with the following equation:

$$P_A = 0.000157Vp$$

where

- P_A = air power, hp
- V = flow rate, cfm
- p = pressure, in. of water

at standard air conditions with air density = 0.075 lb/ft³ built into the multiplier 0.000157. The power necessary at the fan shaft must account for fan inefficiencies, which may vary from 50 to 70%. This may be determined from

$$P_F = P_A / \eta_F$$

where

- P_F = power required at fan shaft, hp
- η_F = fan efficiency, dimensionless

The power necessary at the input to the fan motor must account for fan motor inefficiencies and drive losses. Fan motor efficiencies generally vary from 80 to 95%, and drive losses for a belt drive are 3% of the fan power. This may be determined from

$$P_M = (1 + DL) P_F / E_M E_D$$

where

- P_M = power required at input to motor, hp
- E_D = belt drive efficiency, dimensionless
- E_M = fan motor efficiency, dimensionless
- P_F = power required at fan shaft, hp
- DL = drive loss, dimensionless

Almost all the energy required to generate airflow and static pressure is ultimately dissipated as heat within the building and HVAC system; a small portion is discharged with any exhaust air. Generally, it is assumed that all the heat is released at the fan rather than dispersed to the remainder of the system. The portion of fan heat released to the airstream depends on the location of the fan motor and drive: if they are within the airstream, all the energy input to the fan motor is released to the airstream. If the fan motor and drive are outside the airstream, the energy is split between the airstream and the room housing the motor and drive. Therefore, the following equations may be used to calculate heat generated by fans and motors:

If motor and drive are **outside** the airstream,

$$q_{fs} = 2545P_F$$

$$q_{fr} = 2545(P_M - P_F)$$

If motor and drive are **inside** the airstream,

$$q_{fs} = 2545P_M$$

$$q_{fr} = 0.0$$

where

- P_F = power required at fan shaft, hp
- P_M = power required at input to motor, hp
- q_{fs} = heat release to airstream, Btu/h
- q_{fr} = heat release to room housing motor and drive, Btu/h
- 2545 = conversion factor, Btu/h·hp

Supply airstream temperature rise may be determined from psychrometric formulas or Equation (9).

Variable- or adjustable-frequency drives (VFDs or AFDs) often drive fan motors in VAV air-handling units. These devices release heat to the surrounding space. Refer to manufacturers' data for heat released or efficiencies. The disposition of heat released is determined by the drive's location: in the conditioned space, in the return air path, or in a nonconditioned equipment room. These drives, and other electronic equipment such as building control, data processing, and communications devices, are temperature sensitive, so the rooms in which they are housed require cooling, frequently year-round.

Duct Surface Heat Transfer

Heat transfer across the duct surface is one mechanism for energy transfer to or from air inside a duct. It involves conduction through the duct wall and insulation, convection at inner and outer surfaces, and radiation between the duct and its surroundings. Chapter 4 presents a rigorous analysis of duct heat loss and gain, and Chapter 23 addresses application of analysis to insulated duct systems.

The effect of duct heat loss or gain depends on the duct routing, duct insulation, and its surrounding environment. Consider the following conditions:

- For duct run within the area cooled or heated by air in the duct, heat transfer from the space to the duct has no effect on heating or cooling load, but beware of the potential for condensation on cold ducts.
- For duct run through unconditioned spaces or outdoors, heat transfer adds to the cooling or heating load for the air transport system but not for the conditioned space.
- For duct run through conditioned space not served by the duct, heat transfer affects the conditioned space as well as the air transport system serving the duct.
- For an extensive duct system, heat transfer reduces the effective supply air differential temperature, requiring adjustment through air balancing to increase airflow to extremities of the distribution system.

Duct Leakage

Air leakage from supply ducts can considerably affect HVAC system energy use. Leakage reduces cooling and/or dehumidifying capacity for the conditioned space, and must be offset by increased airflow (sometimes reduced supply air temperatures), unless leaked air enters the conditioned space directly. Supply air leakage into a ceiling return plenum or leakage from unconditioned spaces into return ducts also affects return air temperature and/or humidity.

Determining leakage from a duct system is complex because of the variables in paths, fabrication, and installation methods. Refer to Chapter 21 and publications from the Sheet Metal and Air Conditioning Contractors' National Association (SMACNA) for methods of determining leakage. In general, good-quality ducts and post-installation duct sealing provide highly cost-effective energy savings, with improved thermal comfort and delivery of ventilation air.

Ceiling Return Air Plenum Temperatures

The space above a ceiling, when used as a return air path, is a ceiling return air plenum, or simply a **return plenum**. Unlike a traditional ducted return, the plenum may have multiple heat sources in the air path. These heat sources may be radiant and convective loads from lighting and transformers; conduction loads from adjacent walls, roofs, or glazing; or duct and piping systems within the plenum.

As heat from these sources is picked up by the unducted return air, the temperature differential between the ceiling cavity and conditioned space is small. Most return plenum temperatures do not rise more than 1 to 3°F above space temperature, thus generating only a relatively small thermal gradient for heat transfer through plenum surfaces, except to the outdoors. This yields a relatively large-percentage reduction in space cooling load by shifting plenum loads to the system. Another reason plenum temperatures do not rise more is leakage into the plenum from supply air ducts, and, if exposed to the roof, increasing levels of insulation.

Where the ceiling space is used as a return air plenum, energy balance requires that heat picked up from the lights into the return air (1) become part of the cooling load to the return air (represented by a temperature rise of return air as it passes through the ceiling space), (2) be partially transferred back into the conditioned space through the ceiling material below, and/or (3) be partially lost from the space through floor surfaces above the plenum. If the plenum has one or more exterior surfaces, heat gains through them must be considered; if adjacent to spaces with different indoor temperatures, partition loads must be considered, too. In a multistory building, the conditioned space frequently gains heat through its floor from a similar plenum below, offsetting the floor loss. The radiant component of heat leaving the ceiling or floor surface of a plenum is normally so small, because of relatively small temperature differences, that all such heat transfer is considered convective for calculation purposes (Rock and Wolfe 1997).

Figure 15 shows a schematic of a typical return air plenum. The following equations, using the heat flow directions shown in Figure

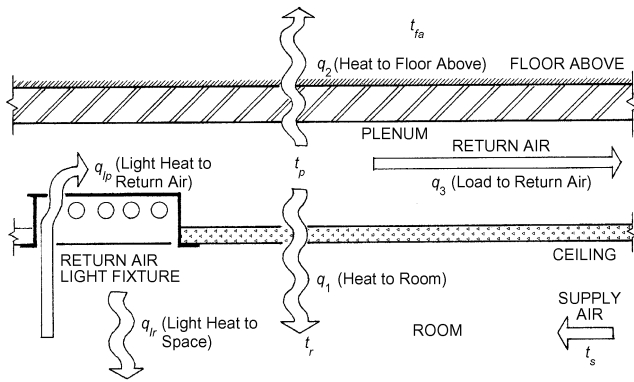

Fig. 15 Schematic Diagram of Typical Return Air Plenum

15, represent the heat balance of a return air plenum design for a typical interior room in a multifloor building:

$$q_1 = U_c A_c (t_p - t_r) \quad (48)$$

$$q_2 = U_f A_f (t_p - t_{fa}) \quad (49)$$

$$q_3 = 1.1 Q (t_p - t_r) \quad (50)$$

$$q_{lp} - q_2 - q_1 - q_3 = 0 \quad (51)$$

$$Q = \frac{q_r + q_1}{1.1(t_r - t_s)} \quad (52)$$

where

- q_1 = heat gain to space from plenum through ceiling, Btu/h
- q_2 = heat loss from plenum through floor above, Btu/h
- q_3 = heat gain “pickup” by return air, Btu/h
- Q = return airflow, cfm
- q_{lp} = light heat gain to plenum via return air, Btu/h
- q_{lr} = light heat gain to space, Btu/h
- q_f = heat gain from plenum below, through floor, Btu/h
- q_w = heat gain from exterior wall, Btu/h
- q_r = space cooling load, including appropriate treatment of q_{lr} , q_f , and/or q_w , Btu/h
- t_p = plenum air temperature, °F
- t_r = space air temperature, °F
- t_{fa} = space air temperature of floor above, °F
- t_s = supply air temperature, °F

By substituting Equations (48), (49), (50), and (52) into heat balance Equation (51), t_p can be found as the resultant return air temperature or plenum temperature. The results, although rigorous and best solved by computer, are important in determining the cooling load, which affects equipment size selection, future energy consumption, and other factors.

Equations (48) to (52) are simplified to illustrate the heat balance relationship. Heat gain into a return air plenum is not limited to heat from lights. Exterior walls directly exposed to the ceiling space can transfer heat directly to or from return air. For single-story buildings or the top floor of a multistory building, roof heat gain or loss enters or leaves the ceiling plenum rather than the conditioned space directly. The supply air quantity calculated by Equation (52) is only for the conditioned space under consideration, and is assumed to equal the return air quantity.

The amount of airflow through a return plenum above a conditioned space may not be limited to that supplied into the space; it will, however, have no noticeable effect on plenum temperature if the surplus comes from an adjacent plenum operating under similar conditions. Where special conditions exist, Equations (48) to (52) must be modified appropriately. Finally, although the building’s thermal storage has some effect, the amount of heat entering the

return air is small and may be considered as convective for calculation purposes.

Ceiling Plenums with Ducted Returns

Compared to those in unducted plenum returns, temperatures in ceiling plenums that have well-sealed return or exhaust air ducts float considerably. In cooling mode, heat from lights and other equipment raises the ceiling plenum’s temperature considerably. Solar heat gain through a poorly insulated roof can drive the ceiling plenum temperature to extreme levels, so much so that heat gains to uninsulated supply air ducts in the plenum can dramatically decrease available cooling capacity to the rooms below. In cold weather, much heat is lost from warm supply ducts. Thus, insulating supply air ducts and sealing them well to minimize air leaks are highly desirable, if not essential. Appropriately insulating roofs and plenums’ exterior walls and minimizing infiltration are also key to lowering total building loads and improving HVAC system performance.

Floor Plenum Distribution Systems

Underfloor air distribution (UFAD) systems are designed to provide comfort conditions in the occupied level and allow stratification to occur above this level of the space. In contrast, room cooling loads determined by methods in this chapter assume uniform temperatures and complete mixing of air within the conditioned space, typically by conventional overhead air distribution systems. Ongoing research projects have identified several factors relating to the load calculation process:

- Heat transfer from a conditioned space with a conventional air distribution system is by convection; radiant loads are converted to convection and transferred to the airstream within the conditioned space.
- A significant fraction of heat transfer with a UFAD system is by radiation directly to the floor surface and, from there, by convection to the airstream in the supply plenum.
- Load at the cooling coil is similar for identical spaces with alternative distribution systems.

Plenums in Load Calculations

Currently, most designers include ceiling and floor plenums within neighboring occupied spaces when thermally zoning a building. However, temperatures in these plenums, and the way that they behave, are significantly different from those of occupied spaces. Thus, they should be defined as a separate thermal zone. However, most hand and computer-based load calculation routines currently do not allow floating air temperatures or humidities; assuming a constant air temperature in plenums, attics, and other unconditioned spaces is a poor, but often necessary, assumption. The heat balance method does allow floating space conditions, and when fully implemented in design load software, should allow more accurate modeling of plenums and other complex spaces.

CENTRAL PLANT

Piping

Losses must be considered for piping systems that transport heat. For water or hydronic piping systems, heat is transferred through the piping and insulation (see Chapter 23 for ways to determine this transfer). However, distribution of this transferred heat depends on the fluid in the pipe and the surrounding environment.

Consider a heating hot-water pipe. If the pipe serves a room heater and is routed through the heated space, any heat loss from the pipe adds heat to the room. Heat transfer to the heated space and heat loss from the piping system is null. If the piping is exposed to ambient conditions en route to the heater, the loss must be considered when selecting the heating equipment; if the pipe is routed

through a space requiring cooling, heat loss from the piping also becomes a load on the cooling system.

In summary, the designer must evaluate both the magnitude of the pipe heat transfer and the routing of the piping.

Pumps

Calculating heat gain from pumps is addressed in the section on Electric Motors. For pumps serving hydronic systems, disposition of heat from the pumps depends on the service. For chilled-water systems, energy applied to the fluid to generate flow and pressure becomes a chiller load. For condenser water pumps, pumping energy must be rejected through the cooling tower. The magnitude of pumping energy relative to cooling load is generally small.

EXAMPLE COOLING AND HEATING LOAD CALCULATIONS

To illustrate the cooling and heating load calculation procedures discussed in this chapter, an example problem has been developed based on building located in Atlanta, Georgia. This example is a two-story office building of approximately 30,000 ft², including a variety of common office functions and occupancies. In addition to demonstrating calculation procedures, a hypothetical design/construction process is discussed to illustrate (1) application of load calculations and (2) the need to develop reasonable assumptions when specific data is not yet available, as often occurs in everyday design processes.

SINGLE-ROOM EXAMPLE

Calculate the peak heating and cooling loads for the conference room shown in Figure 16, for Atlanta, Georgia. The room is on the second floor of a two-story building and has two vertical exterior exposures, with a flat roof above.

Room Characteristics

Area: 274 ft²

Floor: Carpeted 5 in. concrete slab on metal deck above a conditioned space.

Roof: Flat metal deck topped with rigid mineral fiber insulation and perlite board ($R = 12.5$), felt, and light-colored membrane roofing. Space above 9 ft suspended acoustical tile ceiling is used as a return air plenum. Assume 30% of the cooling load from the roof is directly absorbed in the return airstream without becoming room load. Use roof $U = 0.07$ Btu/h·ft²·°F.

Spandrel wall: Spandrel bronze-tinted glass, opaque, backed with air space, rigid mineral fiber insulation ($R = 5.0$), mineral fiber batt insulation ($R = 5.0$), and 5/8 in. gypsum wall board. Use spandrel wall $U = 0.08$ Btu/h·ft²·°F.

Brick wall: Light-brown-colored face brick (4 in.), mineral fiber batt insulation ($R = 10$), lightweight concrete block (6 in.) and gypsum wall board (5/8 in.). Use brick wall $U = 0.08$ Btu/h·ft²·°F.

Windows: Double glazed, 1/4 in. bronze-tinted outside pane, 1/2 in. air space and 1/4 in. clear inside pane with light-colored interior miniblinds. Window normal solar heat gain coefficient (SHGC) = 0.49. Windows are nonoperable and mounted in aluminum frames with thermal breaks having overall combined $U = 0.56$ Btu/h·ft²·°F (based on Type 5d from Tables 4 and 10 of Chapter 15). Inside attenuation coefficients (IACs) for inside miniblinds are based on light venetian blinds (assumed louver reflectance = 0.8 and louvers positioned at 45° angle) with heat-absorbing double glazing (Type 5d from Table 13B of Chapter 15), IAC(0) = 0.74, IAC(60) = 0.65, IAD(diff) = 0.79, and radiant fraction = 0.54. Each window is 6.25 ft wide by 6.4 ft tall for an area per window = 40 ft².

South exposure: Orientation = 30° east of true south
Window area = 40 ft²

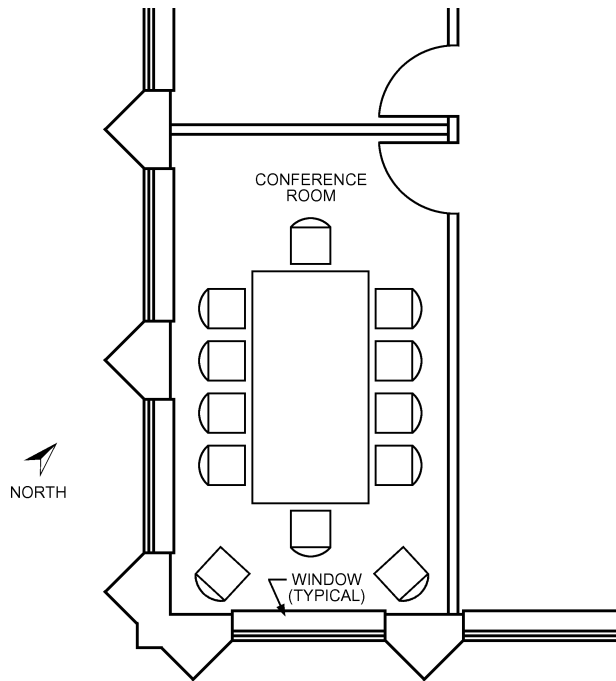

Fig. 16 Single-Room Example Conference Room

	Spandrel wall area	= 60 ft ²
	Brick wall area	= 60 ft ²
<i>West exposure:</i>	Orientation	= 60° west of south
	Window area	= 80 ft ²
	Spandrel wall area	= 120 ft ²
	Brick wall area	= 75 ft ²
<i>Occupancy:</i> 12 people from 8:00 AM to 5:00 PM.		

Lighting: Four 3-lamp recessed fluorescent 2 by 4 ft parabolic reflector (without lens) type with side slot return-air-type fixtures. Each fixture has three 32 W T-8 lamps plus electronic ballasts, for a total of 110 W per fixture or 440 W total for the room. Operation is from 7:00 AM to 7:00 PM. Assume 26% of the cooling load from lighting is directly absorbed in the return air stream without becoming room load, per Table 3.

Equipment: Several computers and a video projector may be used, for which an allowance of 1 W/ft² is to be accommodated by the cooling system, for a total of 274 W for the room. Operation is from 8:00 AM to 5:00 PM.

Infiltration: For purposes of this example, assume the building is maintained under positive pressure during peak cooling conditions and therefore has no infiltration. Assume that infiltration during peak heating conditions is equivalent to one air change per hour.

Weather data: Per Chapter 14, for Atlanta, Georgia, latitude = 33.64, longitude = 84.43, elevation = 1027 ft above sea level, 99.6% heating design dry-bulb temperature = 20.7°F. For cooling load calculations, use 5% dry-bulb/coincident wet-bulb monthly design day profile calculated per Chapter 14. See Table 26 for temperature profiles used in these examples.

Inside design conditions: 72°F for heating; 75°F with 50% rh for cooling.

Cooling Loads Using RTS Method

Traditionally, simplified cooling load calculation methods have estimated the total cooling load at a particular design condition by independently calculating and then summing the load from each component (walls, windows, people, lights, etc). Although the actual heat transfer processes for each component do affect each other, this simplification is appropriate for design load calculations and useful

to the designer in understanding the relative contribution of each component to the total cooling load.

Cooling loads are calculated with the RTS method on a component basis similar to previous methods. The following example parts illustrate cooling load calculations for individual components of this single room for a particular hour and month.

Part 1. Internal cooling load using radiant time series. Calculate the cooling load from lighting at 3:00 PM for the previously described conference room.

Solution: First calculate the 24 h heat gain profile for lighting, then split those heat gains into radiant and convective portions, apply the appropriate RTS to the radiant portion, and sum the convective and radiant cooling load components to determine total cooling load at the designated time. Using Equation (1), the lighting heat gain profile, based on the occupancy schedule indicated is

$$\begin{aligned}
 q_1 &= (440 \text{ W})3.41(0\%) = 0 & q_{13} &= (440 \text{ W})3.41(100\%) = 1500 \\
 q_2 &= (440 \text{ W})3.41(0\%) = 0 & q_{14} &= (440 \text{ W})3.41(100\%) = 1500 \\
 q_3 &= (440 \text{ W})3.41(0\%) = 0 & q_{15} &= (440 \text{ W})3.41(100\%) = 1500 \\
 q_4 &= (440 \text{ W})3.41(0\%) = 0 & q_{16} &= (440 \text{ W})3.41(100\%) = 1500 \\
 q_5 &= (440 \text{ W})3.41(0\%) = 0 & q_{17} &= (440 \text{ W})3.41(100\%) = 1500 \\
 q_6 &= (440 \text{ W})3.41(0\%) = 0 & q_{18} &= (440 \text{ W})3.41(100\%) = 1500 \\
 q_7 &= (440 \text{ W})3.41(100\%) = 1500 & q_{19} &= (440 \text{ W})3.41(0\%) = 0 \\
 q_8 &= (440 \text{ W})3.41(100\%) = 1500 & q_{20} &= (440 \text{ W})3.41(0\%) = 0 \\
 q_9 &= (440 \text{ W})3.41(100\%) = 1500 & q_{21} &= (440 \text{ W})3.41(0\%) = 0 \\
 q_{10} &= (440 \text{ W})3.41(100\%) = 1500 & q_{22} &= (440 \text{ W})3.41(0\%) = 0 \\
 q_{11} &= (440 \text{ W})3.41(100\%) = 1500 & q_{23} &= (440 \text{ W})3.41(0\%) = 0 \\
 q_{12} &= (440 \text{ W})3.41(100\%) = 1500 & q_{24} &= (440 \text{ W})3.41(0\%) = 0
 \end{aligned}$$

The convective portion is simply the lighting heat gain for the hour being calculated times the convective fraction for recessed fluorescent lighting fixtures without lens and with side slot return air, from Table 3:

$$Q_{c,15} = (1500)(52\%) = 780 \text{ Btu/h}$$

The radiant portion of the cooling load is calculated using lighting heat gains for the current hour and past 23 h, the radiant fraction from Table 3 (48%), and radiant time series from Table 19, in accordance with Equation (34). From Table 19, select the RTS for medium-weight construction, assuming 50% glass and carpeted floors as representative of the described construction. Thus, the radiant cooling load for lighting is

$$\begin{aligned}
 Q_{r,15} &= r_0(0.48)q_{15} + r_1(0.48)q_{14} + r_2(0.48)q_{13} + r_3(0.48)q_{12} \\
 &\quad + \dots + r_{23}(0.48)q_{16} \\
 &= (0.49)(0.48)(1500) + (0.17)(0.48)(1500) \\
 &+ (0.09)(0.48)(1500) + (0.05)(0.48)(1500) + (0.03)(0.48)(1500) \\
 &+ (0.02)(0.48)(1500) + (0.02)(0.48)(1500) + (0.01)(0.48)(1500) \\
 &+ (0.01)(0.48)(1500) + (0.01)(0.48)(0) + (0.01)(0.48)(0) \\
 &+ (0.01)(0.48)(0) + (0.01)(0.48)(0) + (0.01)(0.48)(0) \\
 &+ (0.01)(0.48)(0) + (0.01)(0.48)(0) + (0.01)(0.48)(0) \\
 &+ (0.01)(0.48)(0) + (0.01)(0.48)(0) + (0.01)(0.48)(0) \\
 &+ (0.00)(0.48)(0) + (0.00)(0.48)(1500) + (0.00)(0.48)(1500) \\
 &\quad + (0.00)(0.48)(1500) = 641 \text{ Btu/h}
 \end{aligned}$$

The total lighting cooling load at the designated hour is thus

$$Q_{light} = Q_{c,15} + Q_{r,15} = 780 + 641 = 1421 \text{ Btu/h}$$

As noted in the example definition, if it is assumed that 26% of the total lighting load is absorbed by the return air stream, the net lighting cooling load to the room is

$$Q_{light-room, 15} = Q_{light,15} (74\%) = 1421(0.74) = 1052 \text{ Btu/h}$$

See Table 27 for the conference room's lighting usage, heat gain, and cooling load profiles.

Part 2. Wall cooling load using sol-air temperature, conduction time series and radiant time series. Calculate the cooling load contribution from the spandrel wall section facing 60° west of south at 3:00 PM local standard time in July for the previously described conference room.

Solution: Determine the wall cooling load by calculating (1) sol-air temperatures at the exterior surface, (2) heat input based on sol-air temperature, (3) delayed heat gain through the mass of the wall to the interior surface using conduction time series, and (4) delayed space cooling load from heat gain using radiant time series.

First, calculate the sol-air temperature at 3:00 PM local standard time (LST) (4:00 PM daylight saving time) on July 21 for a vertical, dark-colored wall surface, facing 60° west of south, located in Atlanta, Georgia (latitude = 33.64, longitude = 84.43), solar taub = 0.556 and tauδ = 1.779 from monthly Atlanta weather data for July (Table 1 in Chapter 14). From Table 26, the calculated outdoor design temperature for that month and time is 92°F. The ground reflectivity is assumed ρ_g = 0.2.

Sol-air temperature is calculated using Equation (30). For the dark-colored wall, α/h_o = 0.30, and for vertical surfaces, εΔR/h_o = 0. The solar irradiance E_t on the wall must be determined using the equations in Chapter 14:

Solar Angles:

$$\psi = \text{southwest orientation} = +60^\circ$$

Σ = surface tilt from horizontal (where horizontal = 0°) = 90° for vertical wall surface

$$3:00 \text{ PM LST} = \text{hour } 15$$

Calculate solar altitude, solar azimuth, surface solar azimuth, and incident angle as follows:

From Table 2 in Chapter 14, solar position data and constants for July 21 are

$$ET = -6.4 \text{ min}$$

$$\delta = 20.4^\circ$$

$$E_o = 419.8 \text{ Btu/h} \cdot \text{ft}^2$$

$$\text{Local standard meridian (LSM) for Eastern Time Zone} = 75^\circ.$$

Apparent solar time AST

$$\begin{aligned}
 \text{AST} &= \text{LST} + ET/60 + (\text{LSM} - \text{LON})/15 \\
 &= 15 + (-6.4/60) + [(75 - 84.43)/15] \\
 &= 14.2647
 \end{aligned}$$

Hour angle H, degrees

$$\begin{aligned}
 H &= 15(\text{AST} - 12) \\
 &= 15(14.2647 - 12) \\
 &= 33.97^\circ
 \end{aligned}$$

Solar altitude β

$$\begin{aligned}
 \sin \beta &= \cos L \cos \delta \cos H + \sin L \sin \delta \\
 &= \cos(33.64) \cos(20.4) \cos(33.97) + \sin(33.64) \sin(20.4) \\
 &= 0.841 \\
 \beta &= \sin^{-1}(0.841) = 57.2^\circ
 \end{aligned}$$

Solar azimuth φ

$$\begin{aligned}
 \cos \phi &= (\sin \beta \sin L - \sin \delta) / (\cos \beta \cos L) \\
 &= [(\sin(57.2) \sin(33.64) - \sin(20.4))] / [\cos(57.2) \cos(33.64)] \\
 &= 0.258 \\
 \phi &= \cos^{-1}(0.253) = 75.05^\circ
 \end{aligned}$$

Surface-solar azimuth γ

$$\begin{aligned}
 \gamma &= \phi - \psi \\
 &= 75.05 - 60 \\
 &= 15.05^\circ
 \end{aligned}$$

Incident angle θ

$$\begin{aligned}
 \cos \theta &= \cos \beta \cos \gamma \sin \Sigma + \sin \beta \cos \Sigma \\
 &= \cos(57.2) \cos(15.05) \sin(90) + \sin(57.2) \cos(90) \\
 &= 0.523 \\
 \theta &= \cos^{-1}(0.523) = 58.5^\circ
 \end{aligned}$$

Beam normal irradiance E_b

$$\begin{aligned}
 E_b &= E_o \exp(-\tau_b m^{ab}) \\
 m &= \text{relative air mass} \\
 &= 1/[\sin \beta + 0.50572(6.07995 + \beta)^{-1.6364}], \beta \text{ expressed in degrees} \\
 &= 1.18905
 \end{aligned}$$

Table 26 Monthly/Hourly Design Temperatures (5% Conditions) for Atlanta, GA, °F

Hour	January		February		March		April		May		June		July		August		September		October		November		December	
	db	wb	db	wb	db	wb	db	wb	db	wb	db	wb	db	wb	db	wb	db	wb	db	wb	db	wb	db	wb
1	44.1	43.0	47.2	45.9	52.8	48.3	59.2	54.2	66.3	61.9	71.3	66.3	73.8	68.9	73.2	68.9	69.4	65.4	60.9	57.6	53.3	51.8	47.1	46.9
2	43.3	42.5	46.4	45.4	51.9	47.9	58.2	53.8	65.5	61.6	70.4	66.0	73.0	68.6	72.5	68.7	68.6	65.1	60.1	57.3	52.5	51.3	46.3	46.3
3	42.6	42.0	45.8	45.0	51.2	47.5	57.6	53.5	64.9	61.4	69.8	65.8	72.3	68.4	71.9	68.5	68.0	64.9	59.5	57.0	51.9	51.0	45.7	45.7
4	42.0	41.6	45.1	44.7	50.5	47.1	56.9	53.2	64.3	61.2	69.2	65.6	71.7	68.2	71.3	68.3	67.5	64.7	58.9	56.8	51.3	50.6	45.1	45.1
5	41.6	41.3	44.7	44.4	50.0	46.9	56.4	53.0	63.9	61.0	68.8	65.5	71.3	68.1	70.9	68.2	67.1	64.6	58.5	56.6	50.9	50.4	44.7	44.7
6	42.0	41.6	45.1	44.7	50.5	47.1	56.9	53.2	64.3	61.2	69.2	65.6	71.7	68.2	71.3	68.3	67.5	64.7	58.9	56.8	51.3	50.6	45.1	45.1
7	43.5	42.6	46.6	45.6	52.1	48.0	58.5	53.9	65.7	61.7	70.6	66.1	73.2	68.7	72.6	68.7	68.8	65.2	60.3	57.4	52.7	51.4	46.5	46.5
8	47.0	45.1	50.2	47.8	56.1	50.0	62.4	55.5	69.2	63.1	74.1	67.2	76.7	69.7	75.9	69.8	72.0	66.3	63.6	58.9	56.2	53.4	49.8	48.8
9	51.0	47.8	54.2	50.2	60.5	52.3	66.8	57.4	73.1	64.6	78.0	68.5	80.6	70.9	79.6	70.9	75.6	67.6	67.4	60.5	60.0	55.6	53.5	51.3
10	54.5	50.3	57.8	52.4	64.4	54.3	70.7	59.1	76.5	65.9	81.5	69.6	84.1	72.0	82.9	72.0	78.8	68.8	70.7	62.0	63.4	57.5	56.9	53.6
11	57.6	52.5	61.0	54.3	67.9	56.1	74.1	60.5	79.6	67.1	84.6	70.6	87.2	73.0	85.8	72.9	81.7	69.8	73.7	63.3	66.5	59.3	59.8	55.6
12	59.7	53.9	63.1	55.6	70.3	57.3	76.4	61.5	81.6	67.9	86.6	71.2	89.3	73.6	87.8	73.5	83.5	70.4	75.6	64.2	68.5	60.4	61.8	57.0
13	61.4	55.1	64.8	56.7	72.1	58.2	78.3	62.3	83.3	68.5	88.3	71.8	91.0	74.1	89.3	74.0	85.1	71.0	77.2	64.9	70.1	61.3	63.3	58.0
14	62.4	55.8	65.9	57.3	73.3	58.8	79.4	62.8	84.3	68.9	89.3	72.1	92.0	74.4	90.3	74.3	86.0	71.3	78.2	65.3	71.1	61.9	64.3	58.7
15	62.4	55.8	65.9	57.3	73.3	58.8	79.4	62.8	84.3	68.9	89.3	72.1	92.0	74.4	90.3	74.3	86.0	71.3	78.2	65.3	71.1	61.9	64.3	58.7
16	61.2	54.9	64.6	56.5	71.9	58.1	78.0	62.2	83.1	68.4	88.1	71.7	90.8	74.0	89.1	73.9	84.9	70.9	77.0	64.8	69.9	61.2	63.1	57.9
17	59.5	53.8	62.9	55.5	70.0	57.1	76.2	61.4	81.4	67.8	86.4	71.2	89.1	73.5	87.6	73.4	83.4	70.4	75.4	64.1	68.3	60.3	61.6	56.8
18	57.4	52.3	60.8	54.2	67.7	55.9	73.9	60.4	79.4	67.0	84.4	70.5	87.0	72.9	85.6	72.8	81.5	69.7	73.5	63.2	66.3	59.1	59.6	55.5
19	54.3	50.1	57.6	52.3	64.2	54.2	70.4	59.0	76.3	65.8	81.3	69.5	83.9	71.9	82.7	71.9	78.6	68.7	70.5	61.9	63.2	57.4	56.7	53.5
20	52.0	48.6	55.3	50.9	61.7	52.9	67.9	57.9	74.1	65.0	79.1	68.8	81.7	71.3	80.6	71.3	76.6	68.0	68.4	61.0	61.0	56.2	54.5	52.0
21	50.1	47.2	53.4	49.7	59.6	51.8	65.8	57.0	72.3	64.2	77.2	68.2	79.8	70.7	78.9	70.7	74.8	67.3	66.6	60.2	59.2	55.1	52.7	50.8
22	48.3	45.9	51.5	48.5	57.5	50.7	63.8	56.1	70.4	63.5	75.4	67.6	77.9	70.1	77.1	70.2	73.1	66.7	64.8	59.4	57.4	54.1	51.0	49.6
23	46.6	44.8	49.8	47.5	55.6	49.8	61.9	55.4	68.8	62.9	73.7	67.1	76.3	69.6	75.6	69.7	71.6	66.2	63.2	58.7	55.7	53.2	49.4	48.5
24	45.3	43.9	48.5	46.7	54.2	49.0	60.5	54.8	67.6	62.4	72.5	66.7	75.0	69.2	74.4	69.3	70.5	65.8	62.0	58.2	54.5	52.5	48.2	47.7

Table 27 Cooling Load Component: Lighting, Btu/h

Hour	Usage Profile, %	Heat Gain, Btu/h			Nonsolar RTS Zone Type 8, %	Radiant Cooling Load	Total Sensible Cooling Load	% Lighting to Return 26%	Room Sensible Cooling Load
		Convective		Radiant					
		Total	52%	48%					
1	0	—	—	—	49	86	86	22	64
2	0	—	—	—	17	86	86	22	64
3	0	—	—	—	9	79	79	21	59
4	0	—	—	—	5	72	72	19	53
5	0	—	—	—	3	65	65	17	48
6	0	—	—	—	2	58	58	15	43
7	100	1,500	780	720	2	403	1,184	308	876
8	100	1,500	780	720	1	519	1,299	338	961
9	100	1,500	780	720	1	576	1,356	353	1,004
10	100	1,500	780	720	1	605	1,385	360	1,025
11	100	1,500	780	720	1	619	1,400	364	1,036
12	100	1,500	780	720	1	627	1,407	366	1,041
13	100	1,500	780	720	1	634	1,414	368	1,046
14	100	1,500	780	720	1	634	1,414	368	1,046
15	100	1,500	780	720	1	641	1,421	370	1,052
16	100	1,500	780	720	1	648	1,428	371	1,057
17	100	1,500	780	720	1	655	1,436	373	1,062
18	100	1,500	780	720	1	663	1,443	375	1,068
19	0	—	—	—	1	317	317	82	234
20	0	—	—	—	1	202	202	52	149
21	0	—	—	—	0	144	144	37	107
22	0	—	—	—	0	115	115	30	85
23	0	—	—	—	0	101	101	26	75
24	0	—	—	—	0	94	94	24	69
Total		18,005	9,362	8,642	1	8,642	18,005	4,681	13,324

Licensed for single user. © 2009 ASHRAE, Inc.

$$\begin{aligned}
 ab &= \text{beam air mass exponent} \\
 &= 1.219 - 0.043\tau_b - 0.151\tau_d - 0.204\tau_b\tau_d \\
 &= 0.72468 \\
 E_b &= 419.8 \exp[-0.556(1.8905^{0.72468})] \\
 &= 223.5 \text{ Btu/h}\cdot\text{ft}^2
 \end{aligned}$$

$$\begin{aligned}
 \text{Surface beam irradiance } E_{t,b} \\
 E_{t,b} &= E_b \cos \theta \\
 &= (223.5) \cos(58.5) \\
 &= 117 \text{ Btu/h}\cdot\text{ft}^2
 \end{aligned}$$

$$\begin{aligned}
 \text{Ratio } Y \text{ of sky diffuse radiation on vertical surface to sky diffuse radiation on horizontal surface} \\
 Y &= 0.55 + 0.437 \cos \theta + 0.313 \cos^2 \theta \\
 &= 0.55 + 0.437 \cos(58.5) + 0.313 \cos^2(58.5) \\
 &= 0.864
 \end{aligned}$$

$$\begin{aligned}
 \text{Diffuse irradiance } E_d - \text{Horizontal surfaces} \\
 E_d &= E_o \exp(-\tau_d m^{ad}) \\
 ad &= \text{diffuse air mass exponent} \\
 &= 0.202 + 0.852\tau_b - 0.007\tau_d - 0.357\tau_b\tau_d \\
 &= 0.3101417 \\
 E_d &= E_o \exp(-\tau_d m^{ad}) \\
 &= 419.8 \exp(-1.779(1.8905^{0.31017})) \\
 &= 64.24 \text{ Btu/h}\cdot\text{ft}^2
 \end{aligned}$$

$$\begin{aligned}
 \text{Diffuse irradiance } E_d - \text{Vertical surfaces} \\
 E_{t,d} &= E_d Y \\
 &= (64.24)(0.864) \\
 &= 55.5 \text{ Btu/h}\cdot\text{ft}^2
 \end{aligned}$$

$$\begin{aligned}
 \text{Ground reflected irradiance } E_{t,r} \\
 E_{t,r} &= (E_b \sin \beta + E_d) \rho_g (1 - \cos \Sigma) / 2 \\
 &= [223.5 \sin(57.2) + 64.24] (0.2) [1 - \cos(90)] / 2 \\
 &= 25.2 \text{ Btu/h}\cdot\text{ft}^2
 \end{aligned}$$

$$\begin{aligned}
 \text{Total surface irradiance } E_t \\
 E_t &= E_D + E_d + E_r \\
 &= 117 + 55.5 + 25.2 \\
 &= 197.7 \text{ Btu/h}\cdot\text{ft}^2
 \end{aligned}$$

$$\begin{aligned}
 \text{Sol-air temperature [from Equation (30)]:} \\
 T_e &= t_o + \alpha E_t / h_o - \varepsilon \Delta R / h_o \\
 &= 92 + (0.30)(197.7) - 0 \\
 &= 151^\circ\text{F}
 \end{aligned}$$

This procedure is used to calculate the sol-air temperatures for each hour on each surface. Because of the tedious solar angle and intensity calculations, using a simple computer spreadsheet or other computer software can reduce the effort involved. A spreadsheet was used to calculate a 24 h sol-air temperature profile for the data of this example. See Table 28A for the solar angle and intensity calculations and Table 28B for the sol-air temperatures for this wall surface and orientation.

Conductive heat gain is calculated using Equations (31) and (32). First, calculate the 24 h heat input profile using Equation (31) and the sol-air temperatures for a southwest-facing wall with dark exterior color:

$$\begin{aligned}
 q_{i,1} &= (0.08)(120)(73.8 - 75) &= -12 \text{ Btu/h} \\
 q_{i,2} &= (0.08)(120)(73 - 75) &= -19 \\
 q_{i,3} &= (0.08)(120)(72.3 - 75) &= -26 \\
 q_{i,4} &= (0.08)(120)(71.7 - 75) &= -32 \\
 q_{i,5} &= (0.08)(120)(71.3 - 75) &= -36 \\
 q_{i,6} &= (0.08)(120)(72.7 - 75) &= -22 \\
 q_{i,7} &= (0.08)(120)(78.4 - 75) &= 33 \\
 q_{i,8} &= (0.08)(120)(85.9 - 75) &= 104 \\
 q_{i,9} &= (0.08)(120)(93.1 - 75) &= 174 \\
 q_{i,10} &= (0.08)(120)(99.3 - 75) &= 234 \\
 q_{i,11} &= (0.08)(120)(104.5 - 75) &= 283 \\
 q_{i,12} &= (0.08)(120)(109.2 - 75) &= 328 \\
 q_{i,13} &= (0.08)(120)(125.4 - 75) &= 484 \\
 q_{i,14} &= (0.08)(120)(141.4 - 75) &= 638 \\
 q_{i,15} &= (0.08)(120)(151.3 - 75) &= 733 \\
 q_{i,16} &= (0.08)(120)(152.7 - 75) &= 746 \\
 q_{i,17} &= (0.08)(120)(144.8 - 75) &= 670 \\
 q_{i,18} &= (0.08)(120)(126.6 - 75) &= 495 \\
 q_{i,19} &= (0.08)(120)(98 - 75) &= 221 \\
 q_{i,20} &= (0.08)(120)(81.7 - 75) &= 64 \\
 q_{i,21} &= (0.08)(120)(79.8 - 75) &= 46 \\
 q_{i,22} &= (0.08)(120)(77.9 - 75) &= 28
 \end{aligned}$$

$$\begin{aligned}
 q_{i,23} &= (0.08)(120)(76.3 - 75) &= 12 \\
 q_{i,24} &= (0.08)(120)(75 - 75) &= 0
 \end{aligned}$$

Next, calculate wall heat gain using conduction time series. The preceding heat input profile is used with conduction time series to calculate the wall heat gain. From Table 16, the most similar wall construction is wall number 1. This is a spandrel glass wall that has similar mass and thermal capacity. Using Equation (32), the conduction time factors for wall 1 can be used in conjunction with the 24 h heat input profile to determine the wall heat gain at 3:00 PM LST:

$$\begin{aligned}
 q_{15} &= c_0 q_{i,15} + c_1 q_{i,14} + c_2 q_{i,13} + c_3 q_{i,12} + \dots + c_{23} q_{i,14} \\
 &= (0.18)(733) + (0.58)(638) + (0.20)(484) + (0.04)(328) \\
 &\quad + (0.00)(283) + (0.00)(234) + (0.00)(174) + (0.00)(104) \\
 &\quad + (0.00)(33) + (0.00)(-22) + (0.00)(-36) + (0.00)(-32) \\
 &\quad + (0.00)(-26) + (0.00)(-19) + (0.00)(-12) + (0.00)(0) \\
 &\quad + (0.00)(12) + (0.00)(28) + (0.00)(46) + (0.00)(64) \\
 &\quad + (0.00)(221) + (0.00)(495) + (0.00)(670) + (0.00)(746) \\
 &= 612 \text{ Btu/h}
 \end{aligned}$$

Because of the tedious calculations involved, a spreadsheet is used to calculate the remainder of a 24 h heat gain profile indicated in Table 28B for the data of this example.

Finally, calculate wall cooling load using radiant time series. Total cooling load for the wall is calculated by summing the convective and radiant portions. The convective portion is simply the wall heat gain for the hour being calculated times the convective fraction for walls from Table 14 (54%):

$$Q_c = (612)(0.54) = 330 \text{ Btu/h}$$

The radiant portion of the cooling load is calculated using conductive heat gains for the current and past 23 h, the radiant fraction for walls from Table 14 (46%), and radiant time series from Table 19, in accordance with Equation (34). From Table 19, select the RTS for medium-weight construction, assuming 50% glass and carpeted floors as representative for the described construction. Use the wall heat gains from Table 28B for 24 h design conditions in July. Thus, the radiant cooling load for the wall at 3:00 PM is

$$\begin{aligned}
 Q_{r,15} &= r_0(0.46)q_{i,15} + r_1(0.46)q_{i,14} + r_2(0.46)q_{i,13} + r_3(0.46)q_{i,12} \\
 &\quad + \dots + r_{23}(0.46)q_{i,16} \\
 &= (0.49)(0.46)(612) + (0.17)(0.46)(472) + (0.09)(0.46)(344) \\
 &\quad + (0.05)(0.46)(277) + (0.03)(0.46)(225) + (0.02)(0.46)(165) \\
 &\quad + (0.02)(0.46)(97) + (0.01)(0.46)(32) + (0.01)(0.46)(-15) \\
 &\quad + (0.01)(0.46)(-32) + (0.01)(0.46)(-31) + (0.01)(0.46)(-25) \\
 &\quad + (0.01)(0.46)(-18) + (0.01)(0.46)(-10) + (0.01)(0.46)(2) \\
 &\quad + (0.01)(0.46)(15) + (0.01)(0.46)(30) + (0.01)(0.46)(53) \\
 &\quad + (0.01)(0.46)(110) + (0.01)(0.46)(266) + (0.00)(0.46)(491) \\
 &\quad + (0.00)(0.46)(656) + (0.00)(0.46)(725) + (0.00)(0.46)(706) \\
 &= 203 \text{ Btu/h}
 \end{aligned}$$

The total wall cooling load at the designated hour is thus

$$Q_{\text{wall}} = Q_c + Q_{r,15} = 330 + 203 = 533 \text{ Btu/h}$$

Again, a simple computer spreadsheet or other software is necessary to reduce the effort involved. A spreadsheet was used with the heat gain profile to split the heat gain into convective and radiant portions, apply RTS to the radiant portion, and total the convective and radiant loads to determine a 24 h cooling load profile for this example, with results in Table 28B.

Part 3. Window cooling load using radiant time series. Calculate the cooling load contribution, with and without inside shading (venetian blinds) for the window area facing 60° west of south at 3:00 PM in July for the conference room example.

Solution: First, calculate the 24 h heat gain profile for the window, then split those heat gains into radiant and convective portions, apply the appropriate RTS to the radiant portion, then sum the convective and radiant cooling load components to determine total window cooling load for the time. The window heat gain components are calculated using Equations (13) to (15). From Part 2, at hour 15 LST (3:00 PM):

$$\begin{aligned}
 E_{t,b} &= 117 \text{ Btu/h}\cdot\text{ft}^2 \\
 E_{t,d} &= 55.5 \text{ Btu/h}\cdot\text{ft}^2 \\
 E_r &= 25.2 \text{ Btu/h}\cdot\text{ft}^2 \\
 \theta &= 58.5^\circ
 \end{aligned}$$

Table 28A Wall Component of Solar Irradiance

Local Standard Hour	Apparent Solar Time	Hour Angle H	Solar Altitude β	Solar Azimuth φ	Direct Beam Solar			Diffuse Solar Heat Gain					Total Surface Irradiance Btu/h·ft ²
					<i>E_b</i> , Direct Normal Btu/h·ft ²	Surface Incident Angle θ	Surface Direct Btu/h·ft ²	<i>E^d</i> , Diffuse Horizontal, Btu/h·ft ²	Ground Diffuse Btu/h·ft ²	Y Ratio	Sky Diffuse Btu/h·ft ²	Subtotal Diffuse Btu/h·ft ²	
1	0.26	-176	-36	-175	0.0	117.4	0.0	0.0	0.0	0.4500	0.0	0.0	0.0
2	1.26	-161	-33	-159	0.0	130.9	0.0	0.0	0.0	0.4500	0.0	0.0	0.0
3	2.26	-146	-27	-144	0.0	144.5	0.0	0.0	0.0	0.4500	0.0	0.0	0.0
4	3.26	-131	-19	-132	0.0	158.1	0.0	0.0	0.0	0.4500	0.0	0.0	0.0
5	4.26	-116	-9	-122	0.0	171.3	0.0	0.0	0.0	0.4500	0.0	0.0	0.0
6	5.26	-101	3	-113	5.6	172.5	0.0	5.8	0.6	0.4500	2.6	3.2	3.2
7	6.26	-86	14	-105	92.4	159.5	0.0	27.4	5.0	0.4500	12.3	17.3	17.3
8	7.26	-71	27	-98	155.4	145.9	0.0	42.9	11.2	0.4500	19.3	30.5	30.5
9	8.26	-56	39	-90	193.1	132.3	0.0	53.9	17.5	0.4500	24.3	41.8	41.8
10	9.26	-41	51	-81	216.1	118.8	0.0	61.6	23.1	0.4500	27.7	50.8	50.8
11	10.26	-26	63	-67	229.8	105.6	0.0	66.6	27.2	0.4553	30.3	57.5	57.5
12	11.26	-11	74	-39	236.7	92.6	0.0	69.3	29.6	0.5306	36.8	66.4	66.4
13	12.26	4	76	16	238.0	80.2	40.4	69.8	30.1	0.6332	44.2	74.3	114.7
14	13.26	19	69	57	233.8	68.7	85.1	68.1	28.6	0.7505	51.1	79.7	164.8
15	14.26	34	57	75	223.5	58.4	117.0	64.2	25.2	0.8644	55.5	80.7	197.7
16	15.26	49	45	86	205.3	50.4	130.8	57.9	20.3	0.9555	55.3	75.6	206.4
17	16.26	64	32	94	175.5	45.8	122.4	48.5	14.3	1.0073	48.9	63.2	185.6
18	17.26	79	20	102	126.2	45.5	88.4	35.4	7.9	1.0100	35.7	43.6	132.0
19	18.26	94	8	109	44.7	49.7	28.9	16.6	2.3	0.9631	16.0	18.3	47.1
20	19.26	109	-3	117	0.0	57.5	0.0	0.0	0.0	0.8755	0.0	0.0	0.0
21	20.26	124	-14	127	0.0	67.5	0.0	0.0	0.0	0.7630	0.0	0.0	0.0
22	21.26	139	-23	138	0.0	79.0	0.0	0.0	0.0	0.6452	0.0	0.0	0.0
23	22.26	154	-30	151	0.0	91.3	0.0	0.0	0.0	0.5403	0.0	0.0	0.0
24	23.26	169	-35	167	0.0	104.2	0.0	0.0	0.0	0.4618	0.0	0.0	0.0

Table 28B Wall Component of Sol-Air Temperatures, Heat Input, Heat Gain, Cooling Load

Local Standard Hour	Total Surface Irradiance Btu/h·ft ²	Outside Temp., °F	Sol-Air Temp., °F	Inside Temp., °F	Heat Input, Btu/h	CTS Type 1, %	Heat Gain, Btu/h			Nonsolar RTS Zone Type 8, %	Radiant Cooling Load, Btu/h	Total Cooling Load, Btu/h
							Convective		Radiant			
							Total	54%	46%			
1	0.0	73.8	74	75	-12	18	2	1	1	49	32	33
2	0.0	73.0	73	75	-19	58	-10	-5	-4	17	25	20
3	0.0	72.3	72	75	-26	20	-18	-10	-8	9	21	11
4	0.0	71.7	72	75	-32	4	-25	-14	-12	5	17	4
5	0.0	71.3	71	75	-36	0	-31	-17	-14	3	14	-3
6	3.2	71.7	73	75	-22	0	-32	-17	-15	2	12	-5
7	17.3	73.2	78	75	33	0	-15	-8	-7	2	14	5
8	30.5	76.7	86	75	104	0	32	17	15	1	24	41
9	41.8	80.6	93	75	174	0	97	53	45	1	41	94
10	50.8	84.1	99	75	234	0	165	89	76	1	62	151
11	57.5	87.2	104	75	283	0	225	122	104	1	81	203
12	66.4	89.3	109	75	328	0	277	149	127	1	100	249
13	114.7	91.0	125	75	484	0	344	185	158	1	121	306
14	164.8	92.0	141	75	638	0	472	255	217	1	157	412
15	197.7	92.0	151	75	733	0	612	330	281	1	203	533
16	206.4	90.8	153	75	746	0	706	381	325	1	243	624
17	185.6	89.1	145	75	670	0	725	392	334	1	265	657
18	132.0	87.0	127	75	495	0	656	354	302	1	262	617
19	47.1	83.9	98	75	221	0	491	265	226	1	227	492
20	0.0	81.7	82	75	64	0	266	143	122	1	167	310
21	0.0	79.8	80	75	46	0	110	59	50	0	110	169
22	0.0	77.9	78	75	28	0	53	29	25	0	75	104
23	0.0	76.3	76	75	12	0	30	16	14	0	54	70
24	0.0	75.0	75	75	0	0	15	8	7	0	41	49

Licensed for single user. © 2009 ASHRAE, Inc.

Table 29 Window Component of Heat Gain (No Blinds or Overhang)

Local Std. Hour	Beam Solar Heat Gain					Diffuse Solar Heat Gain						Conduction		Total Window Heat Gain, Btu/h		
	Beam Normal, Btu/h·ft ²	Surface Incident Angle	Surface Beam, Btu/h·ft ²	Beam SHGC	Adjusted Beam IAC	Beam Solar Heat Gain, Btu/h	Diffuse Horiz. E _d , Btu/h·ft ²	Ground Diffuse, Btu/h·ft ²	Y Ratio	Sky Diffuse, Btu/h·ft ²	Subtotal Diffuse, Btu/h·ft ²	Hemis. SHGC	Diff. Solar Heat Gain, Btu/h		Out-side Temp., °F	Con-duction Heat Gain, Btu/h
1	0.0	117.4	0.0	0.000	1.000	0	0.0	0.0	0.4500	0.0	0.0	0.410	0	73.8	-54	-54
2	0.0	130.9	0.0	0.000	1.000	0	0.0	0.0	0.4500	0.0	0.0	0.410	0	73.0	-90	-90
3	0.0	144.5	0.0	0.000	1.000	0	0.0	0.0	0.4500	0.0	0.0	0.410	0	72.3	-121	-121
4	0.0	158.1	0.0	0.000	1.000	0	0.0	0.0	0.4500	0.0	0.0	0.410	0	71.7	-148	-148
5	0.0	171.3	0.0	0.000	1.000	0	0.0	0.0	0.4500	0.0	0.0	0.410	0	71.3	-166	-166
6	5.6	172.5	0.0	0.000	0.000	0	5.8	0.6	0.4500	2.6	3.2	0.410	31	71.7	-148	-42
7	92.4	159.5	0.0	0.000	0.000	0	27.4	5.0	0.4500	12.3	17.3	0.410	167	73.2	-81	488
8	155.4	145.9	0.0	0.000	0.000	0	42.9	11.2	0.4500	19.3	30.5	0.410	294	76.7	76	1078
9	193.1	132.3	0.0	0.000	0.000	0	53.9	17.5	0.4500	24.3	41.8	0.410	402	80.6	251	1622
10	216.1	118.8	0.0	0.000	0.000	0	61.6	23.1	0.4500	27.7	50.8	0.410	488	84.1	408	2073
11	229.8	105.6	0.0	0.000	0.000	0	66.6	27.2	0.4553	30.3	57.5	0.410	553	87.2	547	2434
12	236.7	92.6	0.0	0.000	0.000	0	69.3	29.6	0.5306	36.8	66.4	0.410	638	89.3	641	2818
13	238.0	80.2	40.4	0.166	1.000	537	69.8	30.1	0.6332	44.2	74.3	0.410	714	91.0	717	3690
14	233.8	68.7	85.1	0.321	1.000	2183	68.1	28.6	0.7505	51.1	79.7	0.410	766	92.0	762	5559
15	223.5	58.4	117.0	0.398	1.000	3722	64.2	25.2	0.8644	55.5	80.7	0.410	776	92.0	762	7132
16	205.3	50.4	130.8	0.438	1.000	4583	57.9	20.3	0.9555	55.3	75.6	0.410	727	90.8	708	7770
17	175.5	45.8	122.4	0.448	1.000	4392	48.5	14.3	1.0073	48.9	63.2	0.410	607	89.1	632	7096
18	126.2	45.5	88.4	0.449	1.000	3177	35.4	7.9	1.0100	35.7	43.6	0.410	419	87.0	538	5143
19	44.7	49.7	28.9	0.441	1.000	1017	16.6	2.3	0.9631	16.0	18.3	0.410	176	83.9	399	2015
20	0.0	57.5	0.0	0.403	0.000	0	0.0	0.0	0.8755	0.0	0.0	0.410	0	81.7	300	300
21	0.0	67.5	0.0	0.330	0.000	0	0.0	0.0	0.7630	0.0	0.0	0.410	0	79.8	215	215
22	0.0	79.0	0.0	0.185	0.000	0	0.0	0.0	0.6452	0.0	0.0	0.410	0	77.9	130	130
23	0.0	91.3	0.0	0.000	1.000	0	0.0	0.0	0.5403	0.0	0.0	0.410	0	76.3	58	58
24	0.0	104.2	0.0	0.000	1.000	0	0.0	0.0	0.4618	0.0	0.0	0.410	0	75.0	0	0

From Chapter 15, Table 10, for glass type 5d,

$$SHGC(\theta) = SHGC(58.5) = 0.3978 \text{ (interpolated)}$$

$$\langle SHGC \rangle_D = 0.41$$

From Chapter 15, Table 13B, for light-colored blinds (assumed lower reflectance = 0.8 and louvers positioned at 45° angle) on double-glazed, heat-absorbing windows (Type 5d from Table 13B of Chapter 15), IAC(0) = 0.74, IAC(60) = 0.65, IAC(diff) = 0.79, and radiant fraction = 0.54. Without blinds, IAC = 1.0. Therefore, window heat gain components for hour 15, without blinds, are

$$q_{b15} = AE_{t,b} SHGC(\theta)(IAC) = (80)(117)(0.3978)(1.00) = 3722 \text{ Btu/h}$$

$$q_{d15} = A(E_{t,d} + E_p) \langle SHGC \rangle_D (IAC) = (80)(55.5 + 25.2)(0.41)(1.00) = 2648 \text{ Btu/h}$$

$$q_{c15} = UA(t_{out} - t_{in}) = (0.56)(80)(92 - 75) = 762 \text{ Btu/h}$$

This procedure is repeated to determine these values for a 24 h heat gain profile, shown in Table 29.

Total cooling load for the window is calculated by summing the convective and radiant portions. For windows with inside shading (blinds, drapes, etc.), the direct beam, diffuse, and conductive heat gains may be summed and treated together in calculating cooling loads. However, in this example, the window does not have inside shading, and the direct beam solar heat gain should be treated separately from the diffuse and conductive heat gains. The direct beam heat gain, without inside shading, is treated as 100% radiant, and solar RTS factors from Table 20 are used to convert the beam heat gains to cooling loads. The diffuse and conductive heat gains can be totaled and split into radiant and convective portions according to Table 14, and nonsolar RTS factors from Table 19 are used to convert the radiant portion to cooling load.

The solar beam cooling load is calculated using heat gains for the current hour and past 23 h and radiant time series from Table 20, in accordance with Equation (39). From Table 20, select the solar RTS for medium-weight construction, assuming 50% glass and carpeted floors

for this example. Using Table 29 values for direct solar heat gain, the radiant cooling load for the window direct beam solar component is

$$\begin{aligned} Q_{b,15} &= r_0 q_{b,15} + r_1 q_{b,14} + r_2 q_{b,13} + r_3 q_{b,12} + \dots + r_{23} q_{b,14} \\ &= (0.54)(3722) + (0.16)(2183) + (0.08)(537) + (0.04)(0) \\ &\quad + (0.03)(0) + (0.02)(0) + (0.01)(0) + (0.01)(0) + (0.01)(0) \\ &\quad + (0.01)(0) + (0.01)(0) + (0.01)(0) + (0.01)(0) + (0.01)(0) \\ &\quad + (0.01)(0) + (0.01)(0) + (0.01)(0) + (0.01)(0) + (0.01)(0) \\ &\quad + (0.00)(0) + (0.00)(1017) + (0.00)(3177) + (0.00)(4392) \\ &\quad + (0.00)(4583) = 2402 \text{ Btu/h} \end{aligned}$$

This process is repeated for other hours; results are listed in Table 30.

For diffuse and conductive heat gains, the radiant fraction according to Table 14 is 46%. The radiant portion is processed using nonsolar RTS coefficients from Table 19. The results are listed in Tables 29 and 30. For 3:00 PM, the diffuse and conductive cooling load is 3144 Btu/h. The total window cooling load at the designated hour is thus

$$Q_{window} = Q_b + Q_{diff+cond} = 2402 + 3144 = 5546 \text{ Btu/h}$$

Again, a computer spreadsheet or other software is commonly used to reduce the effort involved in calculations. The spreadsheet illustrated in Table 29 is expanded in Table 30 to include splitting the heat gain into convective and radiant portions, applying RTS to the radiant portion, and totaling the convective and radiant loads to determine a 24 h cooling load profile for a window without inside shading.

If the window has an inside shading device, it is accounted for with the inside attenuation coefficients (IAC), the radiant fraction, and the RTS type used. If a window has no inside shading, 100% of the direct beam energy is assumed to be radiant and solar RTS factors are used. However, if an inside shading device is present, the direct beam is assumed to be interrupted by the shading device, and a portion immediately becomes cooling load by convection. Also, the energy is assumed to be radiated to all surfaces of the room, therefore nonsolar RTS values are used to convert the radiant load into cooling load.

IAC values depend on several factors: (1) type of shading device, (2) position of shading device relative to window, (3) reflectivity of shading device, (4) angular adjustment of shading device, as well as (5) solar position relative to the shading device. These factors are discussed

Table 30 Window Component of Cooling Load (No Blinds or Overhang)

Local Standard Hour	Unshaded Direct Beam Solar (if AC = 1)						Shaded Direct Beam (AC < 1.0) + Diffuse + Conduction									Window Cooling Load, Btu/h
	Beam Heat Gain, Btu/h	Convective 0%, Btu/h	Radiant 100%, Btu/h	Solar RTS, Zone Type 8, %	Radiant Btu/h	Cooling Load, Btu/h	Beam Heat Gain, Btu/h	Diffuse Heat Gain, Btu/h	Conduction Heat Gain, Btu/h	Total Heat Gain, Btu/h	Convective 54%, Btu/h	Radiant 46%, Btu/h	Non-solar RTS, Zone Type 8	Radiant Btu/h	Cooling Load, Btu/h	
1	0	0	0	54	196	196	0	0	-54	-54	-29	-25	49	138	109	305
2	0	0	0	16	196	196	0	0	-90	-90	-48	-41	17	118	70	266
3	0	0	0	8	196	196	0	0	-121	-121	-65	-56	9	101	36	232
4	0	0	0	4	196	196	0	0	-148	-148	-80	-68	5	84	4	200
5	0	0	0	3	196	196	0	0	-166	-166	-90	-76	3	67	-23	174
6	0	0	0	2	196	196	0	106	-148	-42	-23	-19	2	81	58	254
7	0	0	0	1	196	196	0	569	-81	488	263	224	2	196	460	656
8	0	0	0	1	191	191	0	1002	76	1078	582	496	1	361	943	1134
9	0	0	0	1	169	169	0	1371	251	1622	876	746	1	539	1415	1583
10	0	0	0	1	132	132	0	1665	408	2073	1119	953	1	705	1824	1956
11	0	0	0	1	86	86	0	1887	547	2434	1314	1119	1	849	2164	2249
12	0	0	0	1	42	42	0	2177	641	2818	1522	1296	1	994	2516	2558
13	537	0	537	1	300	300	0	2436	717	3153	1703	1450	1	1130	2833	3133
14	2183	0	2183	1	1265	1265	0	2614	762	3376	1823	1553	1	1241	3064	4329
15	3722	0	3722	1	2402	2402	0	2648	762	3410	1841	1569	1	1303	3144	5547
16	4583	0	4583	1	3266	3266	0	2479	708	3187	1721	1466	1	1291	3012	6278
17	4392	0	4392	1	3506	3506	0	2072	632	2703	1460	1243	1	1191	2651	6157
18	3177	0	3177	1	3010	3010	0	1429	538	1967	1062	905	1	999	2061	5071
19	1017	0	1017	1	1753	1753	0	599	399	998	539	459	1	717	1256	3008
20	0	0	0	0	832	832	0	0	300	300	162	138	1	456	618	1449
21	0	0	0	0	496	496	0	0	215	215	116	99	0	332	448	945
22	0	0	0	0	334	334	0	0	130	130	70	60	0	255	325	659
23	0	0	0	0	248	248	0	0	58	58	31	27	0	203	234	483
24	0	0	0	0	206	206	0	0	0	0	0	0	0	167	167	373

in detail in Chapter 15. For this example with venetian blinds, the IAC for beam radiation is treated separately from the diffuse solar gain. The direct beam IAC must be adjusted based on the profile angle of the sun. At 3:00 PM in July, the profile angle of the sun relative to the window surface is 58°. Calculated using Equation (45) from Chapter 15, the beam IAC = 0.653. The diffuse IAC is 0.79. Thus, the window heat gains, with light-colored blinds, at 3:00 PM are

$$q_{b15} = AE_D \text{SHGC}(\theta)(\text{IAC}) = (80)(117)(0.3978)(0.653) = 2430 \text{ Btu/h}$$

$$q_{d15} = A(E_d + E_r)(\text{SHGC})_D(\text{IAC})_D = (80)(55.5 + 25.2)(0.41)(0.79) = 2092 \text{ Btu/h}$$

$$q_{c15} = UA(t_{out} - t_{in}) = (0.56)(80)(92 - 75) = 762 \text{ Btu/h}$$

Because the same radiant fraction and nonsolar RTS are applied to all parts of the window heat gain when inside shading is present, those loads can be totaled and the cooling load calculated after splitting the radiant portion for processing with nonsolar RTS. This is illustrated by the spreadsheet results in Table 31. The total window cooling load with venetian blinds at 3:00 PM = 4500 Btu/h .

Part 4. Window cooling load using radiant time series for window with overhang shading. Calculate the cooling load contribution for the previous example with the addition of a 10 ft overhang shading the window.

Solution: In Chapter 15, methods are described and examples provided for calculating the area of a window shaded by attached vertical or horizontal projections. For 3:00 PM LST IN July, the solar position calculated in previous examples is

$$\text{Solar altitude } \beta = 57.2^\circ$$

$$\text{Solar azimuth } \phi = 75.1^\circ$$

$$\text{Surface-solar azimuth } \gamma = 15.1^\circ$$

From Chapter 15, Equation (106), profile angle Ω is calculated by

$$\tan \Omega = \tan \beta / \cos \gamma = \tan(57.2) / \cos(15.1) = 1.6087$$

$$\Omega = 58.1^\circ$$

From Chapter 15, Equation (40), shadow height S_H is

$$S_H = P_H \tan \Omega = 10(1.6087) = 16.1 \text{ ft}$$

Because the window is 6.4 ft tall, at 3:00 PM the window is completely shaded by the 10 ft deep overhang. Thus, the shaded window heat gain includes only diffuse solar and conduction gains. This is converted to cooling load by separating the radiant portion, applying RTS, and adding the resulting radiant cooling load to the convective portion to determine total cooling load. Those results are in Table 32. The total window cooling load = 2631 Btu/h.

Part 5. Room cooling load total. Calculate the sensible cooling loads for the previously described conference room at 3:00 PM in July.

Solution: The steps in the previous example parts are repeated for each of the internal and external loads components, including the southeast facing window, spandrel and brick walls, the southwest facing brick wall, the roof, people, and equipment loads. The results are tabulated in Table 33. The total room sensible cooling load for the conference room is 10,022 Btu/h at 3:00 PM in July. When this calculation process is repeated for a 24 h design day for each month, it is found that the peak room sensible cooling load actually occurs in August at hour 15 (3:00 PM solar time) at 10,126 Btu/h as indicated in Table 34.

Although simple in concept, these steps involved in calculating cooling loads are tedious and repetitive, even using the “simplified” RTS method; practically, they should be performed using a computer spreadsheet or other program. The calculations should be repeated for multiple design conditions (i.e., times of day, other months) to determine the maximum cooling load for mechanical equipment sizing. Example spreadsheets for computing each cooling load component using conduction and radiant time series have been compiled and are available from ASHRAE. To illustrate the full building example discussed previously, those individual component spreadsheets have been compiled to allow calculation of

Table 31 Window Component of Cooling Load (With Blinds, No Overhang)

Local Standard Hour	Unshaded Direct Beam Solar (if AC = 1)						Shaded Direct Beam (AC < 1.0) + Diffuse + Conduction										
	Beam Heat Gain, Btu/h	Con-vective 0%, Btu/h	Radiant 100%, Btu/h	Solar RTS, Zone Type 8, %	Radiant Btu/h	Cooling Load, Btu/h	Beam Heat Gain, Btu/h	Diffuse Heat Gain, Btu/h	Con-duction Heat Gain, Btu/h	Total Heat Gain, Btu/h	Con-vective 54%, Btu/h	Radiant 46%, Btu/h	Non-solar RTS, Zone Type 8	Radiant Btu/h	Cooling Load, Btu/h	Window Cooling Load, Btu/h	
1	0	0	0	1	0	0	0	0	-54	-54	-25	-29	49%	211	186	186	
2	0	0	0	0	0	0	0	0	-90	-90	-41	-48	17%	184	143	143	
3	0	0	0	0	0	0	0	0	-121	-121	-56	-65	9%	165	109	109	
4	0	0	0	0	0	0	0	0	-148	-148	-68	-80	5%	146	78	78	
5	0	0	0	0	0	0	0	0	-166	-166	-76	-90	3%	127	51	51	
6	0	0	0	0	0	0	0	84	-148	-64	-29	-35	2%	140	110	110	
7	0	0	0	0	0	0	0	449	-81	368	169	199	2%	249	419	419	
8	0	0	0	0	0	0	0	791	76	868	399	469	1%	411	810	810	
9	0	0	0	0	0	0	0	1083	251	1334	614	720	1%	587	1200	1200	
10	0	0	0	0	0	0	0	1315	408	1723	793	930	1%	746	1539	1539	
11	0	0	0	0	0	0	0	1491	547	2037	937	1100	1%	880	1817	1817	
12	0	0	0	0	0	0	0	1720	641	2361	1086	1275	1%	1008	2094	2094	
13	0	0	0	0	0	0	349	1925	717	2990	1376	1615	1%	1219	2594	2594	
14	0	0	0	0	0	0	1419	2065	762	4246	1953	2293	1%	1630	3583	3583	
15	0	0	0	0	0	0	2430	2092	762	5284	2431	2853	1%	2070	4500	4500	
16	0	0	0	0	0	0	3062	1958	708	5728	2635	3093	1%	2379	5014	5014	
17	0	0	0	0	0	0	3003	1637	632	5271	2425	2847	1%	2409	4834	4834	
18	0	0	0	0	0	0	2227	1129	538	3893	1791	2102	1%	2093	3883	3883	
19	0	0	0	0	0	0	734	473	399	1606	739	867	1%	1400	2139	2139	
20	0	0	0	0	0	0	0	0	300	300	138	162	1%	814	952	952	
21	0	0	0	0	0	0	0	0	215	215	99	116	0%	555	654	654	
22	0	0	0	0	0	0	0	0	130	130	60	70	0%	406	466	466	
23	0	0	0	0	0	0	0	0	58	58	27	31	0%	314	341	341	
24	0	0	0	0	0	0	0	0	0	0	0	0	0%	254	254	254	

Table 32 Window Component of Cooling Load (With Blinds and Overhang)

Local Standard Hour	Overhang and Fins Shading					Shaded Direct Beam (AC < 1.0) + Diffuse + Conduction										
	Surface Solar Azimuth	Profile Angle	Shadow Width, ft	Shadow Height, ft	Direct Sunlit Area, ft ²	Beam Heat Gain, Btu/h	Diffuse Heat Gain, Btu/h	Con-duction Heat Gain, Btu/h	Total Heat Gain, Btu/h	Con-vective 54%, Btu/h	Radiant 46%, Btu/h	Non-solar RTS, Zone Type 8	Radiant Btu/h	Cooling Load, Btu/h	Window Cooling Load, Btu/h	
1	-235	52	0.0	0.0	0.0	0	0	-54	-54	-29	-25	49%	122	93	93	
2	-219	40	0.0	0.0	0.0	0	0	-90	-90	-48	-41	17%	101	52	52	
3	-204	29	0.0	0.0	0.0	0	0	-121	-121	-65	-56	9%	84	19	19	
4	-192	19	0.0	0.0	0.0	0	0	-148	-148	-80	-68	5%	68	-12	-12	
5	-182	9	0.0	0.0	0.0	0	0	-166	-166	-90	-76	3%	52	-37	-37	
6	-173	-3	0.0	0.0	0.0	0	84	-148	-64	-35	-29	2%	63	28	28	
7	-165	-15	0.0	0.0	0.0	0	449	-81	368	199	169	2%	156	355	355	
8	-158	-28	0.0	0.0	0.0	0	791	76	868	469	399	1%	294	763	763	
9	-150	-43	0.0	0.0	0.0	0	1083	251	1334	720	614	1%	445	1166	1166	
10	-141	-58	0.0	0.0	0.0	0	1315	408	1723	930	793	1%	587	1518	1518	
11	-127	-73	0.0	0.0	0.0	0	1491	547	2037	1100	937	1%	712	1813	1813	
12	-99	-87	0.0	0.0	0.0	0	1720	641	2361	1275	1086	1%	836	2110	2110	
13	-44	80	0.0	6.4	0.0	0	1925	717	2641	1426	1215	1%	950	2377	2377	
14	-3	69	0.0	6.4	0.0	0	2065	762	2827	1527	1300	1%	1041	2567	2567	
15	15	58	0.0	6.4	0.0	0	2092	762	2854	1541	1313	1%	1090	2631	2631	
16	26	48	0.0	6.4	0.0	0	1958	708	2666	1440	1226	1%	1080	2520	2520	
17	34	38	0.0	6.4	0.0	0	1637	632	2268	1225	1043	1%	997	2222	2222	
18	42	26	0.0	4.9	18.9	525	1129	538	2192	1184	1008	1%	959	2142	2142	
19	49	12	0.0	2.2	53.0	486	473	399	1359	734	625	1%	760	1493	1493	
20	57	-6	0.0	0.0	0.0	0	0	300	300	162	138	1%	455	617	617	
21	67	-32	0.0	0.0	0.0	0	0	215	215	116	99	0%	323	439	439	
22	78	-64	0.0	0.0	0.0	0	0	130	130	70	60	0%	241	312	312	
23	91	87	0.0	0.0	0.0	0	0	58	58	31	27	0%	188	219	219	
24	107	67	0.0	0.0	0.0	0	0	0	0	0	0	0%	152	152	152	

Table 33 Single-Room Example Cooling Load (July 3:00 PM) for ASHRAE Example Office Building, Atlanta, GA

		Per Unit Cooling	Room Sensible Cooling, Btu/h	Return Air Sensible Cooling, Btu/h	Room Latent Cooling, Btu/h	Room Sensible Heating, Btu/h
<i>Internal Loads:</i>						
People:	No.	Btu/h · person				
	12	234	2802	—	2400	—
Lighting:		Btu/h · ft ²				
	440 W	3.8	1052	—	—	—
Lighting 26% to RA:		1.3	—	370	—	—
Equipment:	274 W	3.3	904	—	—	—
<i>Envelope Loads:</i>						
Roof:	Roof area, ft ²	Btu/h · ft ²				
Area, ft ² :	274	2.3	627	—	—	984
Roof 30% to RA:			—	269	—	—
Walls:	Wall area, ft ²	Btu/h · ft ²				
Wall Type 1: Brick						
North	0	0.0	—	—	—	—
South	60	1.8	108	—	—	246
East	0	0.0	—	—	—	—
West	75	1.2	93	—	—	308
Wall Type 2: Spandrel						
North	0	0.0	—	—	—	—
South	60	3.2	193	—	—	246
East	0	0.0	—	—	—	—
West	120	4.4	533	—	—	492
Windows:	Window area, ft ²	Btu/h · ft ²				
Window Type 1						
North	0	0.0	—	—	—	—
South	0	0.0	—	—	—	—
East	0	0.0	—	—	—	—
West	0	0.0	—	—	—	—
Window Type 2						
North	0	0.0	—	—	—	—
South	40	27.0	1079	—	—	1149
East	0	0.0	—	—	—	—
West	80	32.9	2631	—	—	2314
<i>Infiltration Loads:</i>	Airflow, cfm	Btu/h · cfm				
Cooling, sensible:	0	0.0	—	—	—	—
Cooling, latent:	0	0.0	—	—	—	—
Heating:	41	56.4	—	—	—	2314
		Room Load Totals:	10,022	638	2400	8038
		Cooling cfm:	506		Heating cfm:	261
		cfm/ft ² :	1.8			

cooling and heating loads on a room by room basis as well as for a “block” calculation for analysis of overall areas or buildings where detailed room-by-room data is not available.

SINGLE-ROOM EXAMPLE PEAK HEATING LOAD

Although the physics of heat transfer that creates a heating load is identical to that for cooling loads, a number of traditionally used simplifying assumptions facilitate a much simpler calculation procedure. As described in the Heating Load Calculations section, design heating load calculations typically assume a single outside temperature, with no heat gain from solar or internal sources, under steady-state conditions. Thus, space heating load is determined by computing the heat transfer rate through building envelope elements ($UAAT$) plus heat required because of outside air infiltration.

Part 6. Room heating load. Calculate the room heating load for the previous described conference room, including infiltration airflow at one air change per hour.

Solution: Because solar heat gain is not considered in calculating design heating loads, orientation of similar envelope elements may be ignored and total areas of each wall or window type combined. Thus, the total spandrel wall area = $60 + 120 = 180$ ft², total brick wall area = $60 + 75 = 135$ ft², and total window area = $40 + 80 = 120$ ft². For this example, use the U-factors that were used for cooling load conditions. In some climates, higher prevalent winds in winter should be considered in calculating U-factors (see Chapter 25 for information on calculating U-factors and surface heat transfer coefficients appropriate for local wind conditions). The 99.6% heating design dry-bulb temperature for Atlanta is 20.7°F and the inside design temperature is 72°F. The room volume with a 9 ft ceiling = $9 \times 274 = 2466$ ft³. At one air change per hour, the infiltration airflow = $1 \times 2466/60 = 41$ cfm. Thus, the heating load is

Windows:	$0.56 \times 120 \times (72 - 20.7) =$	3447 Btu/h
Spandrel Wall:	$0.09 \times 180 \times (72 - 20.7) =$	831
Brick Wall:	$0.08 \times 135 \times (72 - 20.7) =$	554
Roof:	$0.07 \times 274 \times (72 - 20.7) =$	984
Infiltration:	$41 \times 1.1 \times (72 - 20.7) =$	2314
Total Room Heating Load:		8130 Btu/h

Table 34 Single-Room Example Peak Cooling Load (September 5:00 PM) for ASHRAE Example Office Building, Atlanta, GA

		Per Unit Cooling	Room Sensible Cooling, Btu/h	Return Air Sensible Cooling, Btu/h	Room Latent Cooling, Btu/h	Room Sensible Heating, Btu/h
<i>Internal Loads:</i>						
People:	No. 12	Btu/h·person 234	2802	—	2400	—
Lighting:	440 W	Btu/h·ft ² 3.8	1052	—	—	—
Lighting 20% to RA:		1.3	—	370	—	—
Equipment:	274 W	3.3	904	—	—	—
<i>Envelope Loads:</i>						
Roof:	Roof area, ft ²	Btu/h·ft ²				
Area, ft ² :	274	2.1	573	—	—	984
Roof 30% to RA:			—	246	—	—
Walls:	Wall area, ft ²	Btu/h·ft ²				
Wall Type 1: Brick						
North	0	0.0	—	—	—	—
South	60	1.9	116	—	—	246
East	0	0.0	—	—	—	—
West	75	1.2	90	—	—	308
Wall Type 2: Spandrel						
North	0	0.0	—	—	—	—
South	60	3.7	220	—	—	246
East	0	0.0	—	—	—	—
West	120	4.8	570	—	—	492
Windows:	Window area, ft ²	Btu/h·ft ²				
Window Type 1						
North	0	0.0	—	—	—	—
South	0	0.0	—	—	—	—
East	0	0.0	—	—	—	—
West	0	0.0	—	—	—	—
Window Type 2						
North	0	0.0	—	—	—	—
South	40	27.1	1084	—	—	1149
East	0	0.0	—	—	—	—
West	80	33.9	2715	—	—	2298
<i>Infiltration Loads:</i>						
	Airflow, cfm	Btu/h·cfm				
Cooling, sensible:	0	0.0	—	—	—	—
Cooling, latent:	0	0.0	—	—	—	—
Heating:	41	56.4	—	—	—	2314
Room Load Totals:			10,126	615	2400	8038
Cooling cfm:			511		Heating cfm:	261
cfm/ft ² :			1.9			

WHOLE-BUILDING EXAMPLE

Because a single-room example does not illustrate the full application of load calculations, a multistory, multiple-room example building has been developed to show a more realistic case. A hypothetical project development process is described to illustrate its effect on the application of load calculations.

Design Process and Shell Building Definition

A development company has acquired a piece of property in Atlanta, GA, to construct an office building. Although no tenant or end user has yet been identified, the owner/developer has decided to proceed with the project on a speculative basis. They select an architectural design firm, who retains an engineering firm for the mechanical and electrical design.

At the first meeting, the developer indicates the project is to proceed on a fast-track basis to take advantage of market conditions; he is negotiating with several potential tenants who will need to occupy the new building within a year. This requires preparing

shell-and-core construction documents to obtain a building permit, order equipment, and begin construction to meet the schedule.

The shell-and-core design documents will include finished design of the building exterior (the **shell**), as well as permanent interior elements such as stairs, restrooms, elevator, electrical rooms and mechanical spaces (the **core**). The primary mechanical equipment must be sized and installed as part of the shell-and-core package in order for the project to meet the schedule, even though the building occupant is not yet known.

The architect selects a two-story design with an exterior skin of tinted, double-glazed vision glass; opaque, insulated spandrel glass, and brick pilasters. The roof area extends beyond the building edge to form a substantial overhang, shading the second floor windows. Architectural drawings for the shell-and-core package (see [Figures 17 to 22](#)) include plans, elevations, and skin construction details, and are furnished to the engineer for use in “block” heating and cooling load calculations. Mechanical systems and equipment must be specified and installed based on those calculations. (*Note:* Full-size, scalable electronic versions of the drawings in [Figures 17 to](#)

Table 35 Block Load Example: Envelope Area Summary, ft²

Floor Area	Brick Areas				Spandrel/Soffit Areas				Window Areas				
	North	South	East	West	North	South	East	West	North	South	East	West	
First Floor	15,050	680	680	400	400	700	700	360	360	600	560	360	360
Second Floor	15,050	510	510	300	300	1040	1000	540	540	560	600	360	360
Building Total	30,100	1190	1190	700	700	1740	1700	900	900	1160	1160	720	720

22, as well as detailed lighting plans, are available from ASHRAE at www.ashrae.org.)

The HVAC design engineer meets with the developer's operations staff to agree on the basic HVAC systems for the project. Based on their experience operating other buildings and the lack of specific information on the tenant(s), the team decides on two variable-volume air-handling units (AHUs), one per floor, to provide operating flexibility if one floor is leased to one tenant and the other floor to someone else. Cooling will be provided by an air-cooled chiller located on grade across the parking lot. Heating will be provided by electric resistance heaters in parallel-type fan-powered variable-air-volume (VAV) terminal units. The AHUs must be sized quickly to confirm the size of the mechanical rooms on the architectural plans. The AHUs and chiller must be ordered by the mechanical subcontractor within 10 days to meet the construction schedule. Likewise, the electric heating loads must be provided to the electrical engineers to size the electrical service and for the utility company to extend services to the site.

The mechanical engineer must determine the (1) peak airflow and cooling coil capacity for each AHU, (2) peak cooling capacity required for the chiller, and (3) total heating capacity for sizing the electrical service.

Solution: First, calculate "block" heating and cooling loads for each floor to size the AHUs, then calculate a block load for the whole building determine chiller and electric heating capacity.

Based on the architectural drawings, the HVAC engineer assembles basic data on the building as follows:

Location: Atlanta, GA. Per Chapter 14, latitude = 33.64, longitude = 84.43, elevation = 1027 ft above sea level, 99.6% heating design dry-bulb temperature = 20.7°F. For cooling load calculations, use 5% dry-bulb/coincident wet-bulb monthly design day profile from Chapter 14 (on CD-ROM). See Table 26 for temperature profiles used in these examples.

Inside design conditions: 72°F for heating; 75°F with 50% rh for cooling.

Building orientation: Plan north is 30° west of true north.

Gross area per floor: 15,050 ft²

Total building gross area: 30,100 ft²

Windows: Bronze-tinted, double-glazed. Solar heat gain coefficients, U-factors are as in the single-room example.

Walls: Part insulated spandrel glass and part brick-and-block clad columns. The insulation barrier in the soffit at the second floor is similar to that of the spandrel glass and is of lightweight construction; for simplicity, that surface is assumed to have similar thermal heat gain/loss to the spandrel glass. Construction and insulation values are as in single-room example.

Roof: Metal deck, topped with board insulation and membrane roofing. Construction and insulation values are as in the single-room example.

Floor: 5 in. lightweight concrete slab on grade for first floor and 5 in. lightweight concrete on metal deck for second floor

Total areas of building exterior skin, as measured from the architectural plans, are listed in Table 35.

The engineer needs additional data to estimate the building loads. Thus far, no tenant has yet been signed, so no interior layouts for population counts, lighting layouts or equipment loads are available.

To meet the schedule, assumptions must be made on these load components. The owner requires that the system design must be flexible enough to provide for a variety of tenants over the life of the building. Based on similar office buildings, the team agrees to base the block load calculations on the following assumptions:

Occupancy: 7 people per 1000 ft² = 143 ft²/person

Lighting: 1.5 W/ft²

Tenant's office equipment: 1 W/ft²

Normal use schedule is assumed at 100% from 7:00 AM to 7:00 PM and unoccupied/off during other hours.

With interior finishes not finalized, the owner commits to using light-colored interior blinds on all windows. The tenant interior design could include carpeted flooring or acoustical tile ceilings in all areas, but the more conservative assumption, from a peak load standpoint, is chosen: carpeted flooring and no acoustical tile ceilings (no ceiling return plenum).

For block loads, the engineer assumes that the building is maintained under positive pressure during peak cooling conditions and that infiltration during peak heating conditions is equivalent to one air change per hour in a 12 ft deep perimeter zone around the building.

To maintain indoor air quality, outside air must be introduced into the building. Air will be ducted from roof intake hoods to the AHUs where it will be mixed with return air before being cooled and dehumidified by the AHU's cooling coil. ASHRAE *Standard* 62.1 is the design basis for ventilation rates; however, no interior tenant layout is available for application of *Standard* 62.1 procedures. Based on past experience, the engineer decides to use 20 cfm of outside air per person for sizing the cooling coils and chiller.

Block load calculations were performed using the RTS method, and results for the first and second floors and the entire building are summarized in Tables 36, 37, and 38. Based on these results, the engineer performs psychrometric coil analysis, checks capacities versus vendor catalog data, and prepares specifications and schedules for the equipment. This information is released to the contractor with the shell-and-core design documents. The air-handling units and chiller are purchased, and construction proceeds.

Tenant Fit Design Process and Definition

About halfway through construction, a tenant agrees to lease the entire building. The tenant will require a combination of open and enclosed office space with a few common areas, such as conference/training rooms, and a small computer room that will operate on a 24 h basis. Based on the tenant's space program, the architect prepares interior floor plans and furniture layout plans (Figures 23 and 24), and the electrical engineer prepares lighting design plans. Those drawings are furnished to the HVAC engineer to prepare detailed design documents. The first step in this process is to prepare room-by-room peak heating and cooling load calculations, which will then be used for design of the air distribution systems from each of the VAV air handlers already installed.

The HVAC engineer must perform a room-by-room "takeoff" of the architect's drawings. For each room, this effort identifies the floor area, room function, exterior envelope elements and areas, number of occupants, and lighting and equipment loads.

The tenant layout calls for a dropped acoustical tile ceiling throughout, which will be used as a return air plenum. Typical 2 by 4 ft fluorescent, recessed, return-air-type lighting fixtures are

Table 36 Block Load Example—First Floor Loads for ASHRAE Example Office Building, Atlanta, GA

Room Loads: ^a	Per Unit Cooling	Room Sensible Cooling, Btu/h	Return Air Sensible Cooling, Btu/h	Room Latent Cooling, Btu/h	Room Sensible Heating, Btu/h
<i>Internal Loads:</i>					
People:	No. 105	Btu/h·person 238	24,675	—	21,000
Lighting:	22,575 W	Btu/h·ft ² 4.9	73,284	—	—
Lighting 0% to RA:		0.0	—	—	—
Equipment:	15,050 W	3.3	49,780	—	—
<i>Envelope Loads:</i>					
Roof:	Roof area, ft ²	Btu/h·ft ²		—	
Area, ft ² :	—	0.0	—	—	—
Roof 0% to RA:			—	—	—
Walls:	Wall area, ft ²	Btu/h·ft ²			
Wall Type 1: Brick					
North	680	1.3	894	—	2791
South	680	1.9	1297	—	2791
East	400	1.9	743	—	1642
West	400	1.6	639	—	1642
Wall Type 2: Spandrel					
North	700	3.2	2264	—	2873
South	700	2.8	1966	—	2873
East	360	2.6	943	—	1477
West	360	5.2	1872	—	1477
Windows:	Window area, ft ²	Btu/h·ft ²			
Window Type 1:					
North	600	36.5	21,924	—	17,237
South	560	24.4	13,665	—	16,088
East	360	24.3	8755	—	10,342
West	360	64.0	23,040	—	10,342
Window Type 2:					
North	0	0.0	—	—	—
South	0	0.0	—	—	—
East	0	0.0	—	—	—
West	0	0.0	—	—	—
<i>Infiltration Loads:</i>					
	Airflow, cfm	Btu/h·cfm			
Cooling, sensible:	0	0.0	—	—	—
Cooling, latent:	0	0.0	—	—	—
Heating:	863	56.4	—	—	48,499
		Room Load Totals:	225,741	—	21,000
		Cooling cfm:	11,401		Heating cfm:
		cfm/ft ² :	0.8		3905
Block Loads:^b					
	Total Room Sensible + RA + Latent:	246,741		Room heating:	120,273
	Outside air (OA) sensible:	36,498		OA heating:	118,503
OA cfm:	2100	OA latent:	50,267	Total heating, Btu/h:	238,776
Fan hp:	10	Fan heat to supply air:	25,461	Heating Btu/h·ft ² :	15.9
Pump hp:	0	Pump heat to chilled water:	—		
				tons	ft ² /ton
	Total Block Cooling Load, Btu/h:	358,967		29.9	503

^aPeak room sensible load occurs in month 7 at hour 16.

^bPeak block load occurs in month 7 at hour 16.

selected. Based on this, the engineer assumes that 20% of the heat gain from lighting will be to the return air plenum and not enter rooms directly. Likewise, some portion of the heat gain from the roof will be extracted via the ceiling return air plenum. From experience, the engineer understands that return air plenum paths are not always predictable, and decides to credit only 30% of the roof heat gain to the return air, with the balance included in the room cooling load.

For the open office areas, some areas along the building perimeter will have different load characteristics from purely interior spaces because of heat gains and losses through the building skin.

Although those perimeter areas are not separated from other open office spaces by walls, the engineer knows from experience that they must be served by separate control zones to maintain comfort conditions. The data compiled from the room-by-room takeoff are included in Tables 39 and 40.

Room by Room Cooling and Heating Loads

The room by room results of RTS method calculations, including the month and time of day of each room's peak cooling load, are tabulated in supplemental Tables 41 and 42 (available at

Table 37 Block Load Example—Second Floor Loads for ASHRAE Example Office Building, Atlanta, GA

Room Loads: ^a		Per Unit Cooling	Room Sensible Cooling, Btu/h	Return Air Sensible Cooling, Btu/h	Room Latent Cooling, Btu/h	Room Sensible Heating, Btu/h
<i>Internal Loads:</i>						
People:	No. 105	Btu/h·person 234	24,518	—	21,000	—
Lighting:	22,575 W	Btu/h·ft ² 4.8	72,915	—	—	—
Lighting 0% to RA:		0.0	—	—	—	—
Equipment:	15,050 W	3.4	49,626	—	—	—
<i>Envelope Loads:</i>						
Roof:	Roof area, ft ² 15,050	Btu/h·ft ² 3.3	49,202	—	—	54,045
Roof 0% to RA:			—	—	—	—
Walls:	Wall area, ft ²	Btu/h·ft ²				
Wall Type 1: Brick						
North	510	1.1	565	—	—	2093
South	510	1.8	915	—	—	2093
East	300	1.8	545	—	—	1231
West	300	1.2	373	—	—	1231
Wall Type 2: Spandrel						
North	1040	2.8	2865	—	—	4268
South	1000	3.2	3224	—	—	4104
East	540	2.8	1491	—	—	2216
West	540	4.4	2398	—	—	2216
Windows:	Window area, ft ²	Btu/h·ft ²				
Window Type 1:						
North	0	0	—	—	—	—
South	0	0	—	—	—	—
East	0	0	—	—	—	—
West	0	0	—	—	—	—
Window Type 2:						
North	560	28.4	15,916	—	—	16,088
South	600	27.0	16,188	—	—	17,237
East	360	26.1	9,389	—	—	10,342
West	360	32.9	11,840	—	—	10,342
<i>Infiltration Loads:</i>						
	Airflow, cfm	Btu/h·cfm				
Cooling, sensible:	0	0.0	—	—	—	—
Cooling, latent:	0	0.0	—	—	—	—
Heating:	863	56.4	—	—	—	48,699
Room Load Totals:			261,968	—	21,000	176,205
Cooling cfm:			13,231		Heating cfm:	5721
cfm/ft ² :			0.9			
Block Loads:^b						
Total Room Sensible + RA + Latent:			282,968		Room heating:	176,205
Outside air (OA) sensible:			39,270		OA heating:	118,503
OA cfm:	2100	OA latent:	50,908		Total heating, Btu/h:	294,708
Fan hp:	10	Fan heat to supply air:	25,461		Heating Btu/h·ft ² :	19.6
Pump hp:	0	Pump heat to chilled water:	—			
Total Block Cooling Load, Btu/h:			398,607		tons	ft ² /ton
					33.2	453

^aPeak room sensible load occurs in month 7 at hour 15.

^bPeak block load occurs in month 7 at hour 15.

www.ashrae.org), as well as peak heating loads for each room. These results are used by the HVAC engineer to select and design room air distribution devices and to schedule airflow rates for each space. That information is incorporated into the tenant fit drawings and specifications issued to the contractor.

Conclusions

The example results illustrate issues which should be understood and accounted for in calculating heating and cooling loads:

- First, peak room cooling loads occur at different months and times depending on the exterior exposure of the room. Calculation of cooling loads for a single point in time may miss the peak and result in inadequate cooling for that room.
- Often, in real design processes, all data is not known. Reasonable assumptions based on past experience must be made.
- Heating and air-conditioning systems often serve spaces whose use changes over the life of a building. Assumptions used in heating and cooling load calculations should consider reasonable possible uses over the life of the building, not just the first use of the space.

Table 38 Block Load Example—Overall Building Loads for ASHRAE Example Office Building, Atlanta, GA

		Room Sensible Cooling, Btu/h	Return Air Sensible Cooling, Btu/h	Room Latent Cooling, Btu/h	Room Sensible Heating, Btu/h
Room Loads^a	Room Load Totals:	483,550	—	42,000	296,478
	Cooling cfm:	24,422		Heating cfm:	9626
	cfm/ft ² :	0.8			
Block Loads:^b	Total Room Sensible + RA + Latent:	525,550		Room heating:	296,478
	Outside air (OA) sensible:	91,540		OA heating:	237,006
	OA cfm: 4200	OA latent: 101,816		Total heating, Btu/h:	533,484
	Fan hp: 20	Fan heat to supply air: 50,922		Heating Btu/h · ft ² :	17.7
	Pump hp: 5	Pump heat to chilled water: 12,730			
				tons	ft ² /ton
	Total Block Cooling Load, Btu/h:	782,558		65.2	462

^aPeak room sensible load occurs in month 7 at hour 15.

^bPeak block load occurs in month 7 at hour 15.

- The relative importance of each cooling and heating load component varies depending on the portion of the building being considered. Characteristics of a particular window may have little effect on the entire building load, but could have a significant effect on the supply airflow to the room where the window is located and thus on the comfort of the occupants of that space.

PREVIOUS COOLING LOAD CALCULATION METHODS

Procedures described in this chapter are the most current and scientifically derived means for estimating cooling load for a defined building space, but methods in earlier editions of the ASHRAE Handbook are valid for many applications. These earlier procedures are simplifications of the heat balance principles, and their use requires experience to deal with atypical or unusual circumstances. In fact, any cooling or heating load estimate is no better than the assumptions used to define conditions and parameters such as physical makeup of the various envelope surfaces, conditions of occupancy and use, and ambient weather conditions. Experience of the practitioner can never be ignored.

The primary difference between the HB and RTS methods and the older methods is the newer methods' direct approach, compared to the simplifications necessitated by the limited computer capability available previously.

The **transfer function method (TFM)**, for example, required many calculation steps. It was originally designed for energy analysis with emphasis on daily, monthly, and annual energy use, and thus was more oriented to average hourly cooling loads than peak design loads.

The **total equivalent temperature differential method with time averaging (TETD/TA)** has been a highly reliable (if subjective) method of load estimating since its initial presentation in the 1967 *Handbook of Fundamentals*. Originally intended as a manual method of calculation, it proved suitable only as a computer application because of the need to calculate an extended profile of hourly heat gain values, from which radiant components had to be averaged over a time representative of the general mass of the building involved. Because perception of thermal storage characteristics of a given building is almost entirely subjective, with little specific information for the user to judge variations, the TETD/TA method's primary usefulness has always been to the experienced engineer.

The **cooling load temperature differential method with solar cooling load factors (CLTD/CLF)** attempted to simplify the two-step TFM and TETD/TA methods into a single-step technique that proceeded directly from raw data to cooling load without intermediate conversion of radiant heat gain to cooling load. A series of factors were taken from cooling load calculation results (produced

by more sophisticated methods) as “cooling load temperature differences” and “cooling load factors” for use in traditional conduction ($q = U\Delta T$) equations. The results are approximate cooling load values rather than simple heat gain values. The simplifications and assumptions used in the original work to derive those factors limit this method's applicability to those building types and conditions for which the CLTD/CLF factors were derived; the method should not be used beyond the range of applicability.

Although the TFM, TETD/TA, and CLTD/CLF procedures are not republished in this chapter, those methods are not invalidated or discredited. Experienced engineers have successfully used them in millions of buildings around the world. The accuracy of cooling load calculations in practice depends primarily on the availability of accurate information and the design engineer's judgment in the assumptions made in interpreting the available data. Those factors have much greater influence on a project's success than does the choice of a particular cooling load calculation method.

The primary benefit of HB and RTS calculations is their somewhat reduced dependency on purely subjective input (e.g., determining a proper time-averaging period for TETD/TA; ascertaining appropriate safety factors to add to the rounded-off TFM results; determining whether CLTD/CLF factors are applicable to a specific unique application). However, using the most up-to-date techniques in real-world design still requires judgment on the part of the design engineer and care in choosing appropriate assumptions, just as in applying older calculation methods.

REFERENCES

Abushakra, B., J.S. Haberl, and D.E. Claridge. 2004. Overview of literature on diversity factors and schedules for energy and cooling load calculations (1093-RP). *ASHRAE Transactions* 110(1):164-176.

Armstrong, P.R., C.E. Hancock, III, and J.E. Seem. 1992a. Commercial building temperature recovery—Part I: Design procedure based on a step response model. *ASHRAE Transactions* 98(1):381-396.

Armstrong, P.R., C.E. Hancock, III, and J.E. Seem. 1992b. Commercial building temperature recovery—Part II: Experiments to verify the step response model. *ASHRAE Transactions* 98(1):397-410.

ASHRAE. 2004. Thermal environmental conditions for human occupancy. ANSI/ASHRAE Standard 55-2004.

ASHRAE. 2001. Ventilation for acceptable indoor air quality. ANSI/ASHRAE Standard 62-2001.

ASHRAE. 2007. Energy standard for building except low-rise residential buildings. ANSI/ASHRAE/IESNA Standard 90.1-2007.

ASHRAE. 2004. Updating the climatic design conditions in the *ASHRAE Handbook—Fundamentals* (RP-1273). ASHRAE Research Project, Final Report.

ASTM. 2008. Practice for estimate of the heat gain or loss and the surface temperatures of insulated flat, cylindrical, and spherical systems by use of computer programs. Standard C680-08. American Society for Testing and Materials, West Conshohocken, PA.

Table 39 Tenant Fit Example: First Floor Room Data

Room No.	Room Name	Area, ft ²	Brick Area (Wall), ft ²				Spandrel/Soffit Area (Wall), ft ²				Window Area, ft ²				No. of People	Lights, W	Equip., W
			North	South	East	West	North	South	East	West	North	South	East	West			
101	Vestibule	147	60	0	0	0	20	0	0	0	80	0	0	0	0	210	0
102	Reception	314	0	0	0	0	0	0	0	0	0	0	0	0	4	540	314
103	Coats	9	0	0	0	0	0	0	0	0	0	0	0	0	0	0	0
104	Meeting Room	128	40	0	0	0	40	0	0	0	40	0	0	0	6	220	128
105	Mgr. Mtgs./Conf.	128	40	0	0	0	40	0	0	0	40	0	0	0	3	220	128
106	Mgr. Ed./Ch. Prog.	128	40	0	0	0	40	0	0	0	40	0	0	0	1	220	128
107	Admin. Asst.	128	40	0	0	0	40	0	0	0	40	0	0	0	1	220	128
108	Director	271	100	0	80	0	80	0	40	0	80	0	40	0	9	440	271
109	Open Office	1,908	0	0	0	0	0	0	0	0	0	0	0	0	12	2850	1908
109A	E. Open Office	281	0	0	140	0	0	0	160	0	0	0	160	0	3	390	281
110	Member Mgr.	135	0	0	40	0	0	0	40	0	0	0	40	0	1	220	135
111	Member. Files	313	0	0	0	0	0	0	0	0	0	0	0	0	0	660	313
112	Prod./Misc./Stor.	254	0	0	0	0	0	0	0	0	0	0	0	0	0	300	254
113	Storage	218	0	0	40	0	0	0	40	0	0	0	40	0	0	150	0
114	Mailroom	1,464	0	240	100	0	0	200	80	0	0	160	80	0	2	2090	2928
115	Vestibule	77	0	20	0	0	0	20	0	0	0	80	0	0	0	60	0
116	Stair 2	175	0	80	0	0	0	160	0	0	0	0	0	0	0	0	0
117	Elevator Lobby	461	0	0	0	0	0	0	0	0	0	0	0	0	0	610	0
118	Computer/Tel.	397	0	0	0	0	0	0	0	0	0	0	0	0	2	880	397
119	Electrical Equip.	43	0	0	0	0	0	0	0	0	0	0	0	0	0	30	0
120	Storage	30	0	0	0	0	0	0	0	0	0	0	0	0	0	30	0
121	Data Proc. Mgr.	129	0	40	0	0	0	40	0	0	0	40	0	0	1	220	129
122	Open Office	1,812	0	0	0	0	0	0	0	0	0	0	0	0	7	2860	1812
122A	S. Open Office	255	0	120	0	0	0	120	0	0	0	120	0	0	4	660	255
123	Comm. Mgr.	123	0	40	0	0	0	40	0	0	0	40	0	0	1	220	123
123A	Acct. Supervisor	123	0	40	0	0	0	40	0	0	0	40	0	0	2	220	123
124	Acct. Mgr.	123	0	40	0	0	0	40	0	0	0	40	0	0	2	220	123
125	Director	253	0	60	0	100	0	40	0	80	0	40	0	80	5	440	253
126	Admin. Asst.	128	0	0	0	40	0	0	0	40	0	0	0	40	1	220	128
127	Meeting Room	128	0	0	0	40	0	0	0	40	0	0	0	40	6	220	128
128	Assist. B.O.D.	128	0	0	0	40	0	0	0	40	0	0	0	40	1	220	128
129	President	128	0	0	0	40	0	0	0	40	0	0	0	40	1	220	128
130	Conference	225	0	0	0	40	0	0	0	40	0	0	0	40	8	220	225
131	Storage	26	0	0	0	0	0	0	0	0	0	0	0	0	0	0	0
132	Ex. Director	244	60	0	0	100	40	0	0	80	40	0	0	80	5	440	244
133	Ex. Secretary	132	40	0	0	0	40	0	0	0	40	0	0	0	1	220	132
134	Asst. Ex. Dir.	128	40	0	0	0	40	0	0	0	40	0	0	0	1	220	128
135	Storage	14	0	0	0	0	0	0	0	0	0	0	0	0	0	0	0
136	Waiting	311	0	0	0	0	0	0	0	0	0	0	0	0	2	390	311
137	Storage	14	0	0	0	0	0	0	0	0	0	0	0	0	0	0	0
138	Open Office Sec'y	255	0	0	0	0	0	0	0	0	0	0	0	0	3	770	255
139	Conf. A	590	80	0	0	0	80	0	0	0	80	0	0	0	28	780	590
140	Conf. B	580	80	0	0	0	80	0	0	0	80	0	0	0	20	750	580
141	Stair 1	236	60	0	0	0	160	0	0	0	0	0	0	0	0	90	0
142	Conf. C	170	0	0	0	0	0	0	0	0	0	0	0	0	8	440	170
143	Janitor	55	0	0	0	0	0	0	0	0	0	0	0	0	0	75	0
144	Storage	107	0	0	0	0	0	0	0	0	0	0	0	0	0	150	0
145	Men	174	0	0	0	0	0	0	0	0	0	0	0	0	0	420	0
146	Women	174	0	0	0	0	0	0	0	0	0	0	0	0	0	420	0
147	Electrical	57	0	0	0	0	0	0	0	0	0	0	0	0	0	0	0
148	Mechanical	220	0	0	0	0	0	0	0	0	0	0	0	0	0	0	0
149	Hall of Fame	766	0	0	0	0	0	0	0	0	0	0	0	0	0	900	766
150	Personnel Mgr.	120	0	0	0	0	0	0	0	0	0	0	0	0	1	220	120
151	Personnel Clerk	120	0	0	0	0	0	0	0	0	0	0	0	0	2	220	120
Total		15,050	680	680	400	400	700	700	360	360	600	560	360	360	154	22,785	14,279

Table 40 Tenant Fit Example: Second Floor Room Data

Room No.	Room Name	Area, ft ²	Brick Area (Wall), ft ²				Spandrel/Soffit Area (Wall), ft ²				Window Area, ft ²				No. of People	Lights, W	Equip. W
			North	South	East	West	North	South	East	West	North	South	East	West			
201	Mgr. Stds.	131	30	0	0	0	60	0	0	0	40	0	0	0	1	220	131
201A	Admin. Asst.	170	0	0	0	0	0	0	0	0	0	0	0	0	3	330	170
202	Stds. Admin.	128	30	0	0	0	60	0	0	0	40	0	0	0	1	220	128
203	Asst. Mgr. Stds.	128	30	0	0	0	60	0	0	0	40	0	0	0	1	220	128
204	Asst. Mgr. Stds.	128	30	0	0	0	60	0	0	0	40	0	0	0	2	220	128
205	Mgr. Tech. Serv.	128	30	0	0	0	60	0	0	0	40	0	0	0	2	220	128
206	Admin. Asst./Dir.	128	30	0	0	0	60	0	0	0	40	0	0	0	1	220	128
207	Director	252	45	0	75	0	60	0	120	0	40	0	80	0	5	440	252
208	Open Office	1357	0	0	0	0	0	0	0	0	0	0	0	0	8	2480	1357
209	Mgr. Research	128	0	0	30	0	0	0	60	0	0	0	40	0	2	220	128
220	Mgr. Res. Prom.	128	0	0	30	0	0	0	60	0	0	0	40	0	2	220	128
211	Future	128	0	0	30	0	0	0	60	0	0	0	40	0	2	220	128
212	Copy/Storage	115	0	0	0	0	0	0	0	0	0	0	0	0	0	150	115
213	Rare Books Arch.	111	0	0	0	0	0	0	0	0	0	0	0	0	0	150	111
214	Library	802	0	0	0	0	0	0	0	0	0	0	0	0	13	1430	802
215	Corridor	791	0	0	0	0	0	0	0	0	0	0	0	0	0	1480	791
216	Conf. Room	255	0	0	60	0	0	0	120	0	0	0	80	0	12	440	255
217	Storage	560	0	90	75	0	0	180	120	0	0	120	80	0	0	550	560
218	Breakroom	470	0	105	0	0	0	180	0	0	0	120	0	0	16	770	470
219	Stair 2	175	0	60	0	0	0	160	0	0	0	40	0	0	0	220	0
220	Elevator Lobby	124	0	0	0	0	0	0	0	0	0	0	0	0	0	120	0
221	Supplies	160	0	0	0	0	0	0	0	0	0	0	0	0	0	150	160
222	Cam./Darkroom	150	0	0	0	0	0	0	0	0	0	0	0	0	1	150	150
223	Open Office	1,146	0	0	0	0	0	0	0	0	0	0	0	0	8	1760	1146
224	S. Open Office	179	0	60	0	0	0	120	0	0	0	80	0	0	6	440	179
226	Prod. Mgr.	128	0	30	0	0	0	60	0	0	0	40	0	0	2	220	128
227	Graphics Mgr.	128	0	30	0	0	0	60	0	0	0	40	0	0	1	220	128
228	Editor (Handbook)	128	0	30	0	0	0	60	0	0	0	40	0	0	2	220	128
229	Open Office	1,664	0	0	0	0	0	0	0	0	0	0	0	0	7	2750	1664
229A	S. Open Office	159	0	45	0	0	0	120	0	0	0	80	0	0	5	440	159
229	W. Open Office	233	0	0	0	90	0	0	0	180	0	0	0	120	5	660	233
230	Conf. Room	274	0	60	0	75	0	60	0	120	0	40	0	80	12	440	274
231	Editor	128	0	0	0	30	0	0	0	60	0	0	0	40	1	220	128
232	Editor	128	0	0	0	30	0	0	0	60	0	0	0	40	2	220	128
233	Director	252	45	0	0	75	60	0	0	120	40	0	0	80	7	440	252
234	Admin. Asst.	128	30	0	0	0	60	0	0	0	40	0	0	0	1	220	128
235	Adv. Sales Mgr.	128	30	0	0	0	60	0	0	0	40	0	0	0	1	220	128
235A	Adv. Prod. Mgr.	128	30	0	0	0	60	0	0	0	40	0	0	0	1	220	128
236	Comm/P.R. Mgr.	128	30	0	0	0	60	0	0	0	40	0	0	0	1	220	128
237	Conf. Room	128	30	0	0	0	60	0	0	0	40	0	0	0	6	220	128
238	Marketing Mgr.	128	30	0	0	0	60	0	0	0	40	0	0	0	1	220	128
239	Open Office	1,001	0	0	0	0	0	0	0	0	0	0	0	0	6	2200	1001
240	Storage	230	0	0	0	0	0	0	0	0	0	0	0	0	0	225	0
241	Stair 1	252	60	0	0	0	200	0	0	0	0	0	0	0	0	440	0
242	Corridor	111	0	0	0	0	0	0	0	0	0	0	0	0	0	90	0
243	Hall of Fame	545	0	0	0	0	0	0	0	0	0	0	0	0	0	690	0
244	Janitor	55	0	0	0	0	0	0	0	0	0	0	0	0	0	75	0
245	Storage	107	0	0	0	0	0	0	0	0	0	0	0	0	0	75	0
246	Men	174	0	0	0	0	0	0	0	0	0	0	0	0	0	420	0
247	Women	174	0	0	0	0	0	0	0	0	0	0	0	0	0	420	0
248	Electrical	57	0	0	0	0	0	0	0	0	0	0	0	0	0	0	0
249	Mechanical	220	0	0	0	0	0	0	0	0	0	0	0	0	0	0	0
250	Storage	173	0	0	0	0	0	0	0	0	0	0	0	0	0	225	0
Total		15,050	510	510	300	300	1040	1000	540	540	560	600	360	360	147	25,050	12,654

- Bliss, R.J.V. 1961. Atmospheric radiation near the surface of the ground. *Solar Energy* 5(3):103.
- Chantrasrisalai, C., D.E. Fisher, I. Iu, and D. Eldridge. 2003. Experimental validation of design cooling load procedures: The heat balance method. *ASHRAE Transactions* 109(2):160-173.
- Claridge, D.E., B. Abushakra, J.S. Haberl, and A. Sreshthaputra. 2004. Electricity diversity profiles for energy simulation of office buildings (RP-1093). *ASHRAE Transactions* 110(1):365-377.
- Eldridge, D., D.E. Fisher, I. Iu, and C. Chantrasrisalai. 2003. Experimental validation of design cooling load procedures: Facility design (RP-1117). *ASHRAE Transactions* 109(2):151-159.
- Fisher, D.R. 1998. New recommended heat gains for commercial cooking equipment. *ASHRAE Transactions* 104(2):953-960.
- Fisher, D.E. and C. Chantrasrisalai. 2006. Lighting heat gain distribution in buildings (RP-1282). ASHRAE Research Project, *Final Report*.
- Fisher, D.E. and C.O. Pedersen. 1997. Convective heat transfer in building energy and thermal load calculations. *ASHRAE Transactions* 103(2): 137-148.
- Gordon, E.B., D.J. Horton, and F.A. Parvin. 1994. Development and application of a standard test method for the performance of exhaust hoods with commercial cooking appliances. *ASHRAE Transactions* 100(2).
- Hittle, D.C. 1999. The effect of beam solar radiation on peak cooling loads. *ASHRAE Transactions* 105(2):510-513.
- Hittle, D.C. and C.O. Pedersen. 1981. Calculating building heating loads using the frequency of multi-layered slabs. *ASHRAE Transactions* 87(2):545-568.
- Hosni, M.H. and B.T. Beck. 2008. Update to measurements of office equipment heat gain data (RP-1482). ASHRAE Research Project, *Progress Report*.
- Hosni, M.H., B.W. Jones, J.M. Sipes, and Y. Xu. 1998. Total heat gain and the split between radiant and convective heat gain from office and laboratory equipment in buildings. *ASHRAE Transactions* 104(1A):356-365.
- Hosni, M.H., B.W. Jones, and H. Xu. 1999. Experimental results for heat gain and radiant/convective split from equipment in buildings. *ASHRAE Transactions* 105(2):527-539.
- Incropera, F.P. and D.P. DeWitt. 1990. *Fundamentals of heat and mass transfer*, 3rd ed. Wiley, New York.
- Iu, I. and D.E. Fisher. 2004. Application of conduction transfer functions and periodic response factors in cooling load calculation procedures. *ASHRAE Transactions* 110(2):829-841.
- Iu, I., C. Chantrasrisalai, D.S. Eldridge, and D.E. Fisher. 2003. experimental validation of design cooling load procedures: The radiant time series method (RP-1117). *ASHRAE Transactions* 109(2):139-150.
- Jones, B.W., M.H. Hosni, and J.M. Sipes. 1998. Measurement of radiant heat gain from office equipment using a scanning radiometer. *ASHRAE Transactions* 104(1B):1775-1783.
- Karambakkam, B.K., B. Nigusse, and J.D. Spitler. 2005. A one-dimensional approximation for transient multi-dimensional conduction heat transfer in building envelopes. *Proceedings of the 7th Symposium on Building Physics in the Nordic Countries*, The Icelandic Building Research Institute, Reykjavik, vol. 1, pp. 340-347.
- Kerrisk, J.F., N.M. Schnurr, J.E. Moore, and B.D. Hunn. 1981. The custom weighting-factor method for thermal load calculations in the DOE-2 computer program. *ASHRAE Transactions* 87(2):569-584.
- Komor, P. 1997. Space cooling demands from office plug loads. *ASHRAE Journal* 39(12):41-44.
- Kusuda, T. 1967. *NBSLD, the computer program for heating and cooling loads for buildings*. BSS 69 and NBSIR 74-574. National Bureau of Standards.
- Latta, J.K. and G.G. Boileau. 1969. Heat losses from house basements. *Canadian Building* 19(10):39.
- LBL. 2003. *WINDOW 5.2: A PC program for analyzing window thermal performance for fenestration products*. LBL-44789. Windows and Day-lighting Group. Lawrence Berkeley Laboratory, Berkeley.
- Liesen, R.J. and C.O. Pedersen. 1997. An evaluation of inside surface heat balance models for cooling load calculations. *ASHRAE Transactions* 103(2):485-502.
- Marn, W.L. 1962. Commercial gas kitchen ventilation studies. *Research Bulletin* 90(March). Gas Association Laboratories, Cleveland, OH.
- McClellan, T.M. and C.O. Pedersen. 1997. Investigation of outside heat balance models for use in a heat balance cooling load calculation procedure. *ASHRAE Transactions* 103(2):469-484.
- McQuiston, F.C. and J.D. Spitler. 1992. *Cooling and heating load calculation manual*, 2nd ed. ASHRAE.
- Miller, A. 1971. *Meteorology*, 2nd ed. Charles E. Merrill, Columbus.
- Nigusse, B.A. 2007. *Improvements to the radiant time series method cooling load calculation procedure*. Ph.D. dissertation, Oklahoma State University.
- Parker, D.S., J.E.R. McIlvaine, S.F. Barkaszi, D.J. Beal, and M.T. Anello. 2000. *Laboratory testing of the reflectance properties of roofing material*. FSEC-CR670-00. Florida Solar Energy Center, Cocoa.
- Pedersen, C.O., D.E. Fisher, and R.J. Liesen. 1997. Development of a heat balance procedure for calculating cooling loads. *ASHRAE Transactions* 103(2):459-468.
- Pedersen, C.O., D.E. Fisher, J.D. Spitler, and R.J. Liesen. 1998. *Cooling and heating load calculation principles*. ASHRAE.
- Rees, S.J., J.D. Spitler, M.G. Davies, and P. Haves. 2000. Qualitative comparison of North American and U.K. cooling load calculation methods. *International Journal of Heating, Ventilating, Air-Conditioning and Refrigerating Research* 6(1):75-99.
- Rock, B.A. 2005. A user-friendly model and coefficients for slab-on-grade load and energy calculation. *ASHRAE Transactions* 111(2):122-136.
- Rock, B.A. and D.J. Wolfe. 1997. A sensitivity study of floor and ceiling plenum energy model parameters. *ASHRAE Transactions* 103(1):16-30.
- Smith, V.A., R.T. Swierczyna, and C.N. Claar. 1995. Application and enhancement of the standard test method for the performance of commercial kitchen ventilation systems. *ASHRAE Transactions* 101(2).
- Sowell, E.F. 1988a. Cross-check and modification of the DOE-2 program for calculation of zone weighting factors. *ASHRAE Transactions* 94(2).
- Sowell, E.F. 1988b. Load calculations for 200,640 zones. *ASHRAE Transactions* 94(2):716-736.
- Spitler, J.D. and D.E. Fisher. 1999a. Development of periodic response factors for use with the radiant time series method. *ASHRAE Transactions* 105(2):491-509.
- Spitler, J.D. and D.E. Fisher. 1999b. On the relationship between the radiant time series and transfer function methods for design cooling load calculations. *International Journal of Heating, Ventilating, Air-Conditioning and Refrigerating Research* (now *HVAC&R Research*) 5(2):125-138.
- Spitler, J.D., D.E. Fisher, and C.O. Pedersen. 1997. The radiant time series cooling load calculation procedure. *ASHRAE Transactions* 103(2).
- Spitler, J.D., S.J. Rees, and P. Haves. 1998. Quantitative comparison of North American and U.K. cooling load calculation procedures—Part I: Methodology, Part II: Results. *ASHRAE Transactions* 104(2):36-46, 47-61.
- Sun, T.-Y. 1968. Shadow area equations for window overhangs and side-fins and their application in computer calculation. *ASHRAE Transactions* 74(1):I-1.1 to I-1.9.
- Swierczyna, R., P. Sobiski, and D. Fisher. 2008. Revised heat gain and capture and containment exhaust rates from typical commercial cooking appliances (RP-1362). ASHRAE Research Project, *Final Report*.
- Swierczyna, R., P.A. Sobiski, and D.R. Fisher. 2009 (forthcoming). Revised heat gain rates from typical commercial cooking appliances from RP-1362. *ASHRAE Transactions* 115(2).
- Talbert, S.G., L.J. Canigan, and J.A. Eibling. 1973. An experimental study of ventilation requirements of commercial electric kitchens. *ASHRAE Transactions* 79(1):34.
- Walton, G. 1983. *Thermal analysis research program reference manual*. National Bureau of Standards.
- Wilkins, C.K. and M.R. Cook. 1999. Cooling loads in laboratories. *ASHRAE Transactions* 105(1):744-749.
- Wilkins, C.K. and M.H. Hosni. 2000. Heat gain from office equipment. *ASHRAE Journal* 42(6):33-44.
- Wilkins, C.K. and N. McGaffin. 1994. Measuring computer equipment loads in office buildings. *ASHRAE Journal* 36(8):21-24.
- Wilkins, C.K., R. Kosonen, and T. Laine. 1991. An analysis of office equipment load factors. *ASHRAE Journal* 33(9):38-44.

BIBLIOGRAPHY

- Alereza, T. and J.P. Breen, III. 1984. Estimates of recommended heat gain due to commercial appliances and equipment. *ASHRAE Transactions* 90(2A):25-58.
- Alford, J.S., J.E. Ryan, and F.O. Urban. 1939. Effect of heat storage and variation in outdoor temperature and solar intensity on heat transfer through walls. *ASHVE Transactions* 45:387.
- American Gas Association. 1948. *A comparison of gas and electric use for commercial cooking*. Cleveland, OH.
- American Gas Association. 1950. *Gas and electric consumption in two college cafeterias*. Cleveland, OH.

- ASHRAE. 1975. *Procedure for determining heating and cooling loads for computerized energy calculations, algorithms for building heat transfer subroutines*.
- ASHRAE. 1979. *Cooling and heating load calculation manual*.
- BLAST Support Office. 1991. *BLAST user reference*. University of Illinois, Urbana-Champaign.
- Brisken, W.R. and G.E. Reque. 1956. Thermal circuit and analog computer methods, thermal response. *ASHAE Transactions* 62:391.
- Buchberg, H. 1958. Cooling load from thermal network solutions. *ASHAE Standard* 64:111.
- Buchberg, H. 1955. Electric analog prediction of the thermal behavior of an inhabitable enclosure. *ASHAE Transactions* 61:339-386.
- Buffington, D.E. 1975. Heat gain by conduction through exterior walls and roofs—Transmission matrix method. *ASHRAE Transactions* 81(2):89.
- Burch, D.M., B.A. Peavy, and F.J. Powell. 1974. Experimental validation of the NBS load and indoor temperature prediction model. *ASHRAE Transactions* 80(2):291.
- Burch, D.M., J.E. Seem, G.N. Walton, and B.A. Licitra. 1992. Dynamic evaluation of thermal bridges in a typical office building. *ASHRAE Transactions* 98:291-304.
- Butler, R. 1984. The computation of heat flows through multi-layer slabs. *Building and Environment* 19(3):197-206.
- Ceylan, H.T. and G.E. Myers. 1985. Application of response-coefficient method to heat-conduction transients. *ASHRAE Transactions* 91:30-39.
- Chiles, D.C. and E.F. Sowell. 1984. A counter-intuitive effect of mass on zone cooling load response. *ASHRAE Transactions* 91(2A):201-208.
- Chorpining, B.T. 1997. The sensitivity of cooling load calculations to window solar transmission models. *ASHRAE Transactions* 103(1).
- Clarke, J.A. 1985. *Energy simulation in building design*. Adam Hilger Ltd., Boston.
- Consolazio, W. and L.J. Pecora. 1947. Minimal replenishment air required for living spaces. *ASHVE Standard* 53:127.
- Colliver, D.G., H. Zhang, R.S. Gates, and K.T. Priddy. 1995. Determination of the 1%, 2.5%, and 5% occurrences of extreme dew-point temperatures and mean coincident dry-bulb temperatures. *ASHRAE Transactions* 101(2):265-286.
- Colliver, D.G., R.S. Gates, H. Zhang, and K.T. Priddy. 1998. Sequences of extreme temperature and humidity for design calculations. *ASHRAE Transactions* 104(1A):133-144.
- Colliver, D.G., R.S. Gates, T.F. Burke, and H. Zhang. 2000. Development of the design climatic data for the 1997 ASHRAE Handbook—Fundamentals. *ASHRAE Transactions* 106(1):3-14.
- Davies, M.G. 1996. A time-domain estimation of wall conduction transfer function coefficients. *ASHRAE Transactions* 102(1):328-208.
- DeAlbuquerque, A.J. 1972. Equipment loads in laboratories. *ASHRAE Journal* 14(10):59.
- Falconer, D.R., E.F. Sowell, J.D. Spitler, and B.B. Todorovich. 1993. Electronic tables for the ASHRAE load calculation manual. *ASHRAE Transactions* 99(1):193-200.
- Harris, S.M. and F.C. McQuiston. 1988. A study to categorize walls and roofs on the basis of thermal response. *ASHRAE Transactions* 94(2):688-714.
- Headrick, J.B. and D.P. Jordan. 1969. Analog computer simulation of heat gain through a flat composite roof section. *ASHRAE Transactions* 75(2):21.
- Hittle, D.C. 1981. Calculating building heating and cooling loads using the frequency response of multilayered slabs, Ph.D. dissertation, Department of Mechanical and Industrial Engineering, University of Illinois, Urbana-Champaign.
- Hittle, D.C. and R. Bishop. 1983. An improved root-finding procedure for use in calculating transient heat flow through multilayered slabs. *International Journal of Heat and Mass Transfer* 26:1685-1693.
- Houghton, D.G., C. Gutherlet, and A.J. Wahl. 1935. ASHVE Research Report No. 1001—Cooling requirements of single rooms in a modern office building. *ASHVE Transactions* 41:53.
- Kimura and Stephenson. 1968. Theoretical study of cooling loads caused by lights. *ASHRAE Transactions* 74(2):189-197.
- Kusuda, T. 1969. Thermal response factors for multilayer structures of various heat conduction systems. *ASHRAE Transactions* 75(1):246.
- Leopold, C.S. 1947. The mechanism of heat transfer, panel cooling, heat storage. *Refrigerating Engineering* 7:33.
- Leopold, C.S. 1948. Hydraulic analogue for the solution of problems of thermal storage, radiation, convection, and conduction. *ASHVE Transactions* 54:3-9.
- Livermore, J.N. 1943. Study of actual vs predicted cooling load on an air conditioning system. *ASHVE Transactions* 49:287.
- Mackey, C.O. and N.R. Gay. 1949. Heat gains are not cooling loads. *ASHVE Transactions* 55:413.
- Mackey, C.O. and N.R. Gay. 1952. Cooling load from sunlit glass. *ASHVE Transactions* 58:321.
- Mackey, C.O. and N.R. Gay. 1954. Cooling load from sunlit glass and wall. *ASHVE Transactions* 60:469.
- Mackey, C.O. and L.T. Wright, Jr. 1944. Periodic heat flow—homogeneous walls or roofs. *ASHVE Transactions* 50:293.
- Mackey, C.O. and L.T. Wright, Jr. 1946. Periodic heat flow—composite walls or roofs. *ASHVE Transactions* 52:283.
- Mast, W.D. 1972. Comparison between measured and calculated hour heating and cooling loads for an instrumented building. *ASHRAE Symposium Bulletin* 72(2).
- McBridge, M.F., C.D. Jones, W.D. Mast, and C.F. Sepsey. 1975. Field validation test of the hourly load program developed from the ASHRAE algorithms. *ASHRAE Transactions* 1(1):291.
- Mitalas, G.P. 1968. Calculations of transient heat flow through walls and roofs. *ASHRAE Transactions* 74(2):182-188.
- Mitalas, G.P. 1969. An experimental check on the weighting factor method of calculating room cooling load. *ASHRAE Transactions* 75(2):22.
- Mitalas, G.P. 1972. Transfer function method of calculating cooling loads, heat extraction rate, and space temperature. *ASHRAE Journal* 14(12):52.
- Mitalas, G.P. 1973. Calculating cooling load caused by lights. *ASHRAE Transactions* 75(6):7.
- Mitalas, G.P. 1978. Comments on the Z-transfer function method for calculating heat transfer in buildings. *ASHRAE Transactions* 84(1):667-674.
- Mitalas, G.P. and J.G. Arsenault. 1970. Fortran IV program to calculate Z-transfer functions for the calculation of transient heat transfer through walls and roofs. *Use of Computers for Environmental Engineering Related to Buildings*, pp. 633-668. National Bureau of Standards, Gaithersburg, MD.
- Mitalas, G.P. and K. Kimura. 1971. A calorimeter to determine cooling load caused by lights. *ASHRAE Transactions* 77(2):65.
- Mitalas, G.P. and D.G. Stephenson. 1967. Room thermal response factors. *ASHRAE Transactions* 73(2): III.2.1.
- Nevins, R.G., H.E. Straub, and H.D. Ball. 1971. Thermal analysis of heat removal troffers. *ASHRAE Transactions* 77(2):58-72.
- NFPA. 1999. Standard for health care facilities. *Standard* 99-99. National Fire Protection Association, Quincy, MA.
- Nottage, H.B. and G.V. Parmelee. 1954. Circuit analysis applied to load estimating. *ASHVE Transactions* 60:59.
- Nottage, H.B. and G.V. Parmelee. 1955. Circuit analysis applied to load estimating. *ASHAE Transactions* 61(2):125.
- Ouyang, K. and F. Haghghat. 1991. A procedure for calculating thermal response factors of multi-layer walls—State space method. *Building and Environment* 26(2):173-177.
- Parmelee, G.V., P. Vance, and A.N. Cherny. 1957. Analysis of an air conditioning thermal circuit by an electronic differential analyzer. *ASHAE Transactions* 63:129.
- Paschakis, V. 1942. Periodic heat flow in building walls determined by electric analog method. *ASHVE Transactions* 48:75.
- Peavy, B.A. 1978. A note on response factors and conduction transfer functions. *ASHRAE Transactions* 84(1):688-690.
- Peavy, B.A., F.J. Powell, and D.M. Burch. 1975. Dynamic thermal performance of an experimental masonry building. *NBS Building Science Series* 45 (July).
- Romine, T.B., Jr. 1992. Cooling load calculation: Art or science? *ASHRAE Journal*, 34(1):14.
- Rudoy, W. 1979. Don't turn the tables. *ASHRAE Journal* 21(7):62.
- Rudoy, W. and F. Duran. 1975. Development of an improved cooling load calculation method. *ASHRAE Transactions* 81(2):19-69.
- Seem, J.E., S.A. Klein, W.A. Beckman, and J.W. Mitchell. 1989. Transfer functions for efficient calculation of multidimensional transient heat transfer. *Journal of Heat Transfer* 111:5-12.
- Sowell, E.F. and D.C. Chiles. 1984a. Characterization of zone dynamic response for CLF/CLTD tables. *ASHRAE Transactions* 91(2A):162-178.
- Sowell, E.F. and D.C. Chiles. 1984b. Zone descriptions and response characterization for CLF/CLTD calculations. *ASHRAE Transactions* 91(2A):179-200.
- Spitler, J.D. 1996. *Annotated guide to load calculation models and algorithms*. ASHRAE.

- Spitler, J.D., F.C. McQuiston, and K.L. Lindsey. 1993. The CLTD/SCL/CLF cooling load calculation method. *ASHRAE Transactions* 99(1):183-192.
- Spitler, J.D. and F.C. McQuiston. 1993. Development of a revised cooling and heating calculation manual. *ASHRAE Transactions* 99(1):175-182.
- Stephenson, D.G. 1962. Method of determining non-steady-state heat flow through walls and roofs at buildings. *Journal of the Institution of Heating and Ventilating Engineers* 30:5.
- Stephenson, D.G. and G.P. Mitalas. 1967. Cooling load calculation by thermal response factor method. *ASHRAE Transactions* 73(2):III.1.1.
- Stephenson, D.G. and G.P. Mitalas. 1971. Calculation of heat transfer functions for multi-layer slabs. *ASHRAE Transactions* 77(2):117-126.
- Stewart, J.P. 1948. Solar heat gain through walls and roofs for cooling load calculations. *ASHVE Transactions* 54:361.
- Sun, T.-Y. 1968. Computer evaluation of the shadow area on a window cast by the adjacent building. *ASHRAE Journal* (September).
- Todorovic, B. 1982. Cooling load from solar radiation through partially shaded windows, taking heat storage effect into account. *ASHRAE Transactions* 88(2):924-937.
- Todorovic, B. 1984. Distribution of solar energy following its transmittal through window panes. *ASHRAE Transactions* 90(1B):806-815.
- Todorovic, B. 1987. The effect of the changing shade line on the cooling load calculations. In ASHRAE videotape, *Practical applications for cooling load calculations*.
- Todorovic, B. 1989. *Heat storage in building structure and its effect on cooling load; Heat and mass transfer in building materials and structure*. Hemisphere Publishing, New York.
- Todorovic, B. and D. Curcija. 1984. Calculative procedure for estimating cooling loads influenced by window shading, using negative cooling load method. *ASHRAE Transactions* 2:662.
- Todorovic, B., L. Marjanovic, and D. Kovacevic. 1993. Comparison of different calculation procedures for cooling load from solar radiation through a window. *ASHRAE Transactions* 99(2):559-564.
- Vild, D.J. 1964. Solar heat gain factors and shading coefficients. *ASHRAE Journal* 6(10):47.
- Wilkins, C.K. 1998. Electronic equipment heat gains in buildings. *ASHRAE Transactions* 104(1B):1784-1789.
- York, D.A. and C.C. Cappiello. 1981. *DOE-2 engineers manual* (Version 2.1A). Lawrence Berkeley Laboratory and Los Alamos National Laboratory.

BUILDING EXAMPLE DRAWINGS

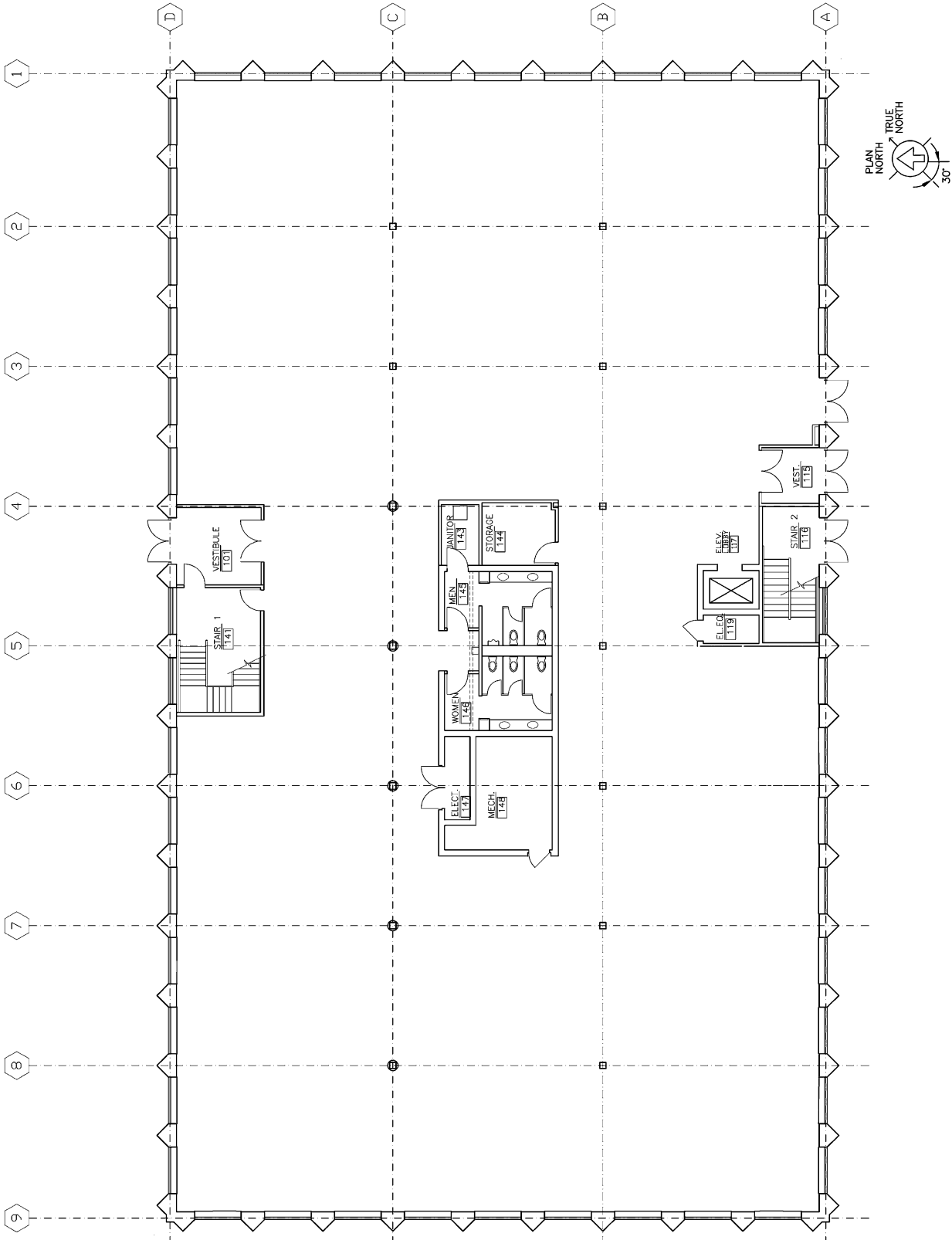

Fig. 17 First Floor Shell and Core Plan
(not to scale)

Licensed for single user. © 2009 ASHRAE, Inc.

Licensed for single user. © 2009 ASHRAE, Inc.

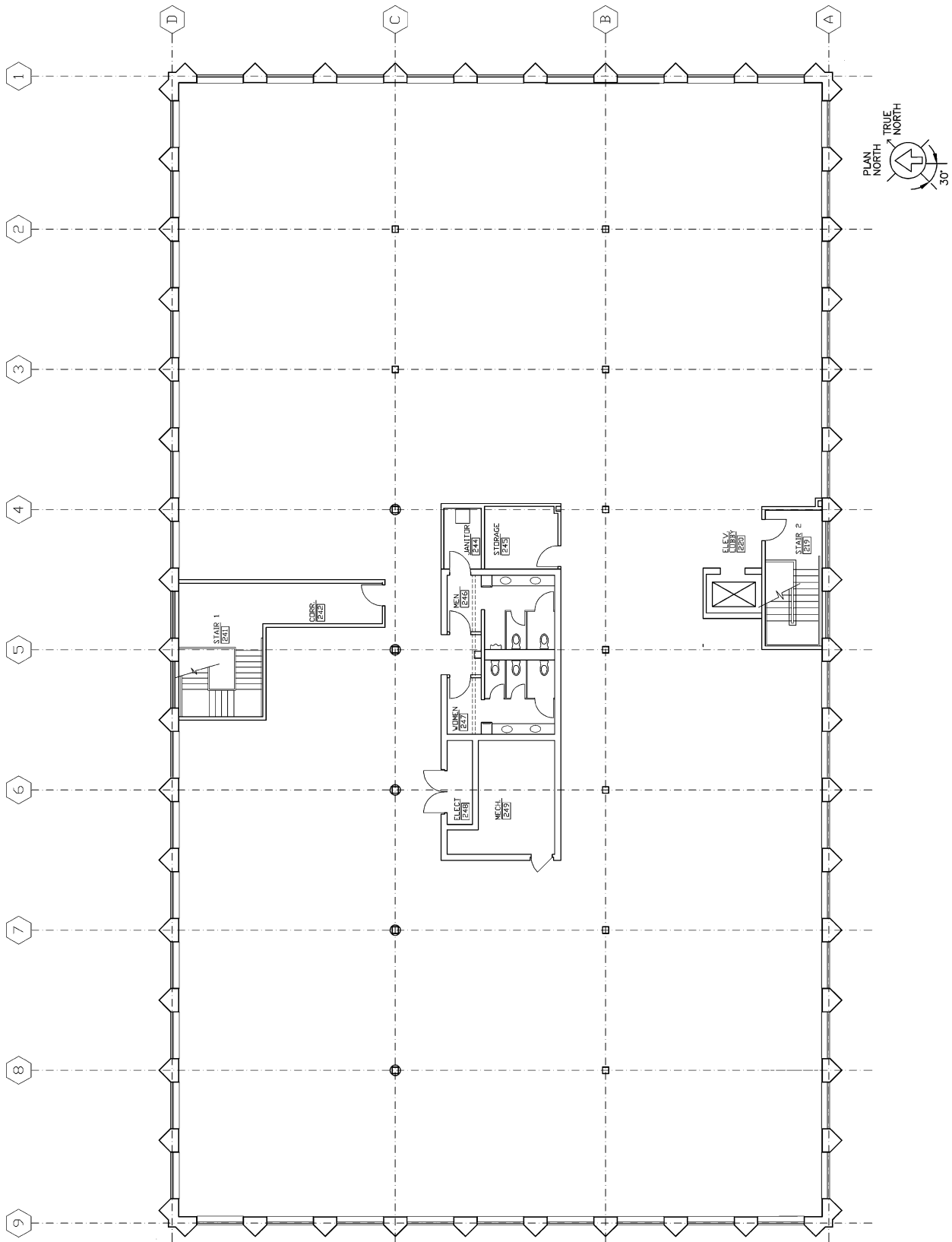

Fig. 18 Second Floor Shell and Core Plan
(not to scale)

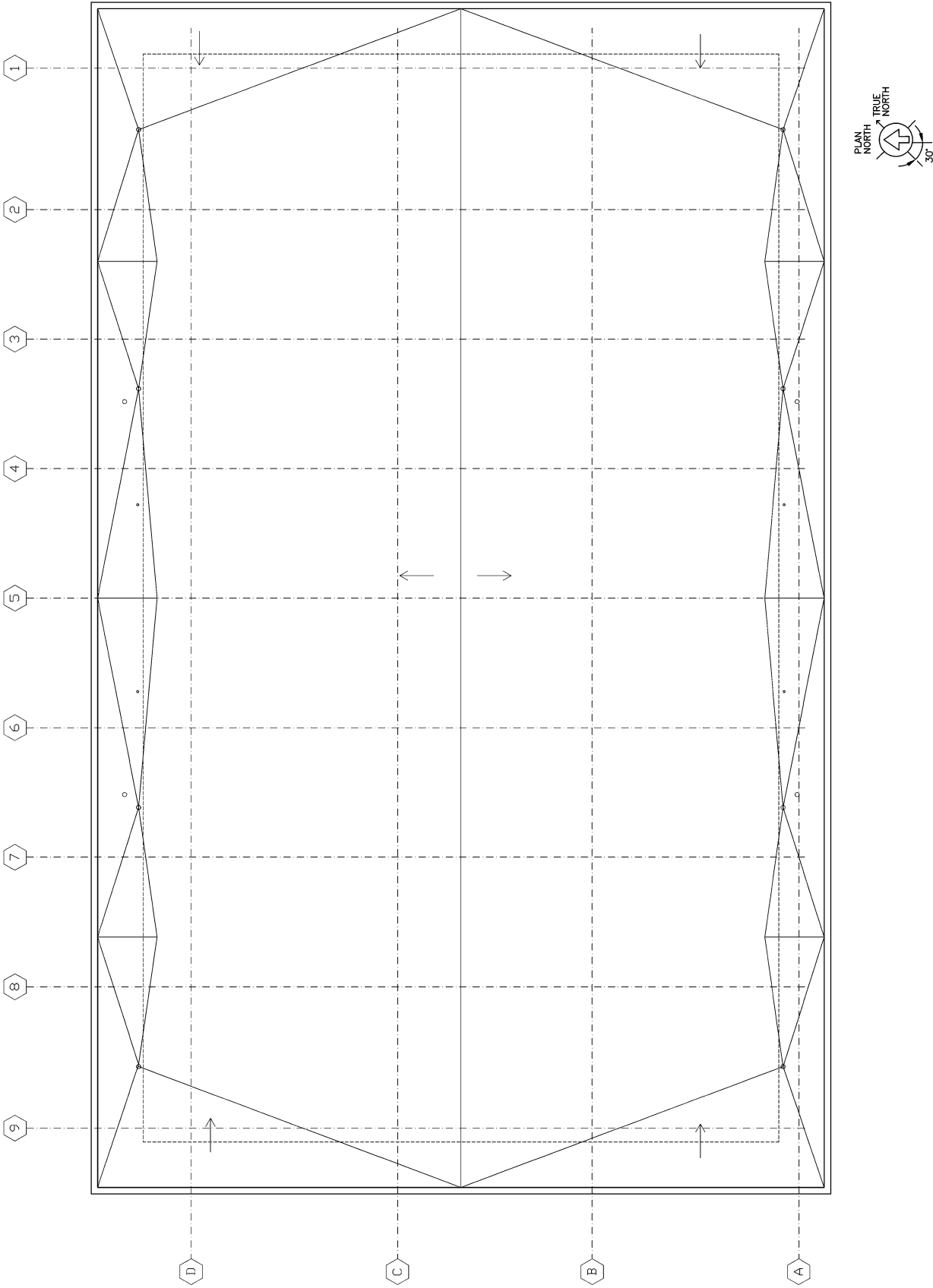
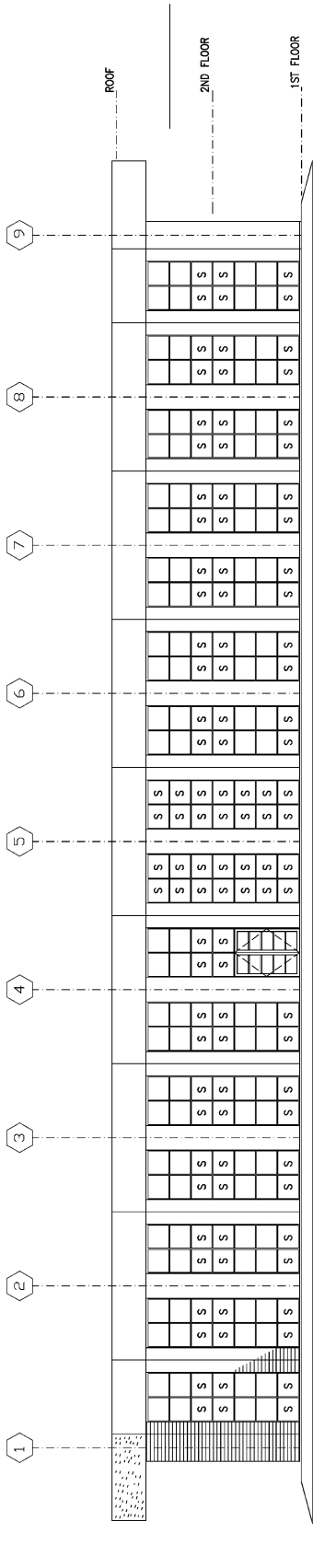
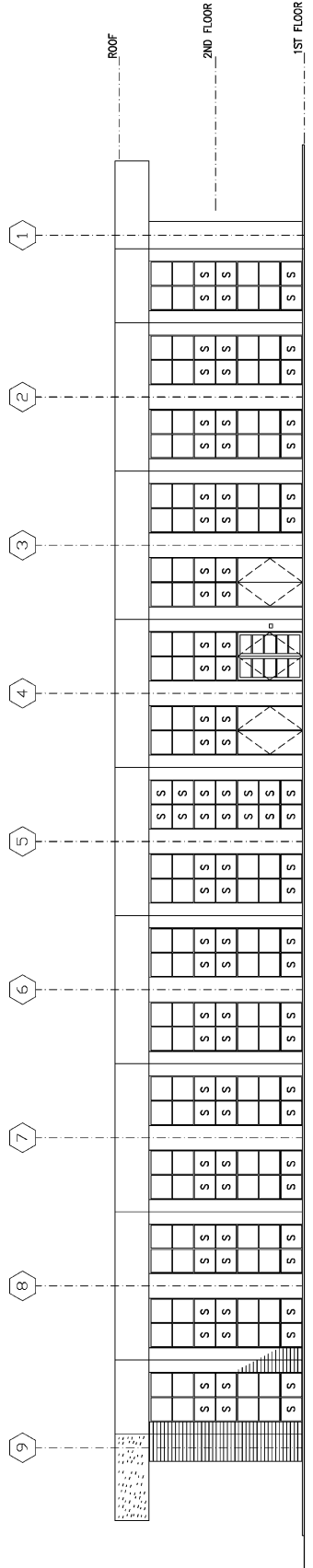

Fig. 19 Roof Plan
(not to scale)



NORTH ELEVATION



NOTE: ALL GLASS SHALL BE VISION GLASS UNLESS OTHERWISE NOTED WITH "S" INDICATING SPANDREL GLASS.

SOUTH ELEVATION

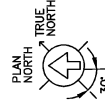

Fig. 20 North/South Elevations
(not to scale)

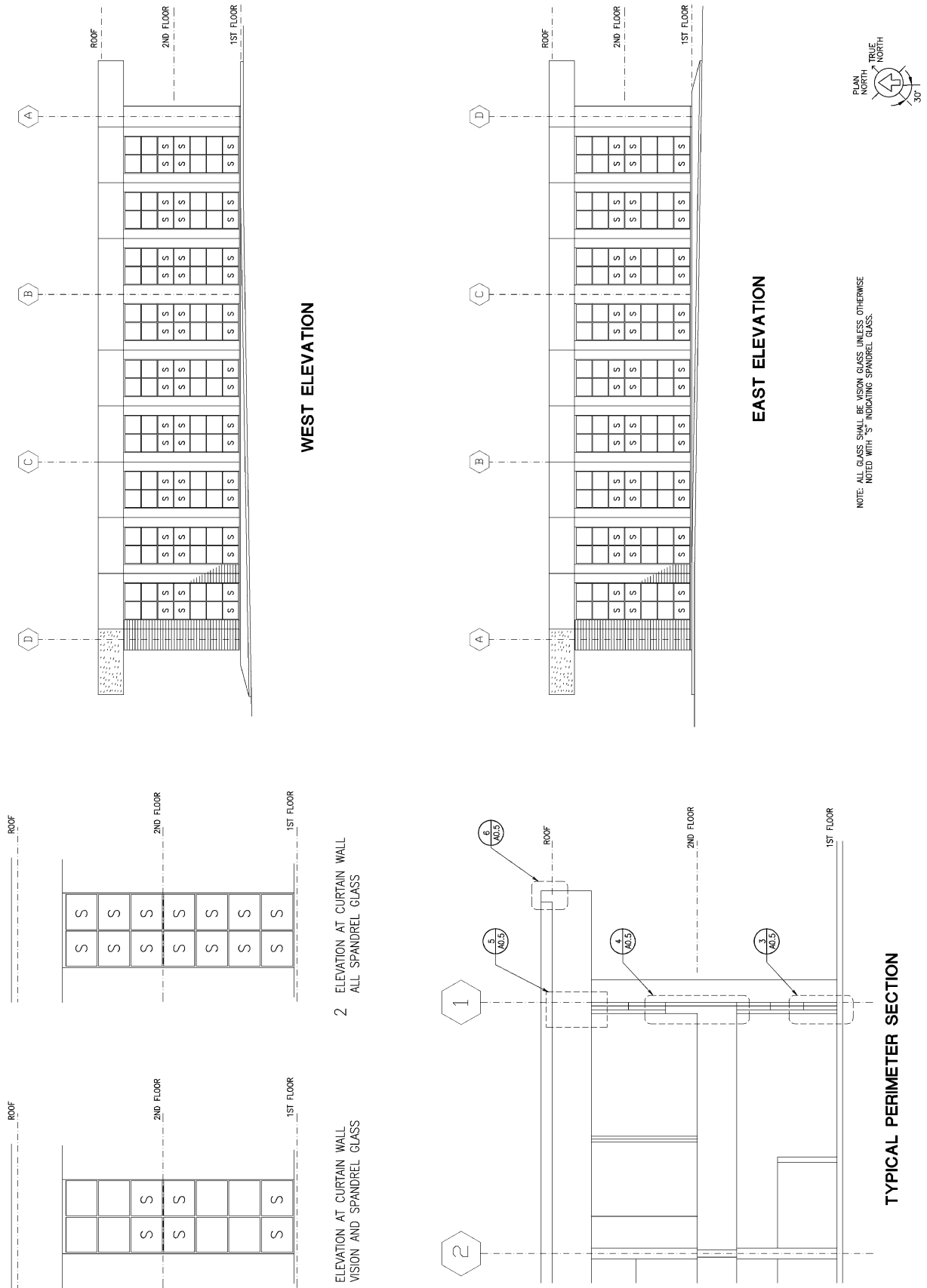
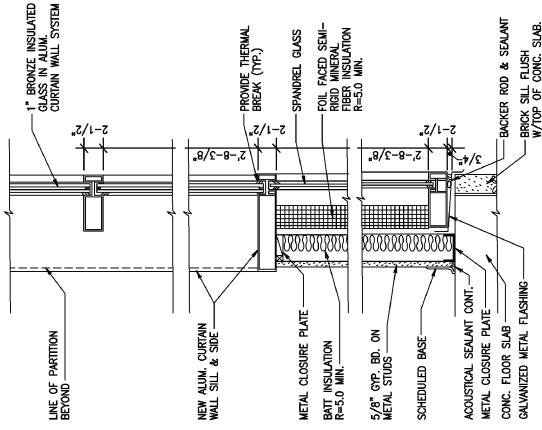
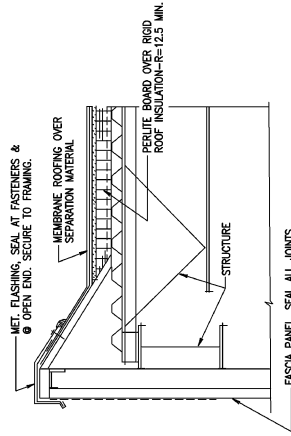

Fig. 21 East/West Elevations, Elevation Details, and Perimeter Section (not to scale)



3 SECTION AT SILL
A0.6



6 TYPICAL SECTION AT PARAPET
A0.6

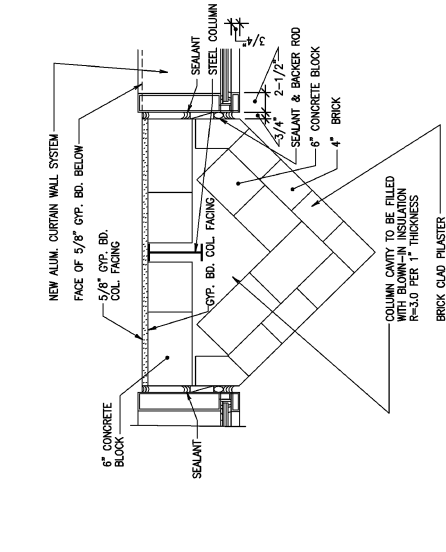

2 CURTAIN PLAN DETAIL AT VISION GLASS
A0.6

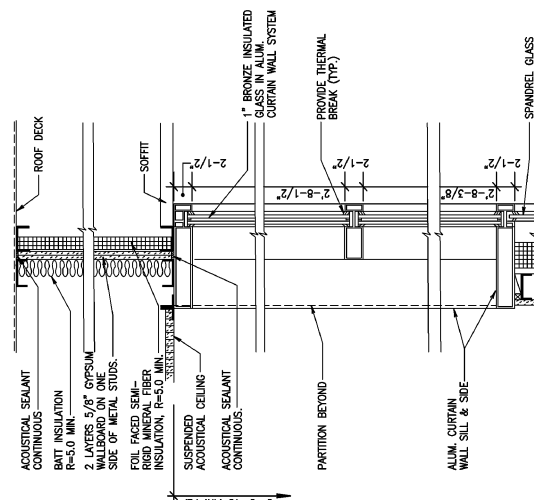

5 SECTION AT CURTAIN AND SOFFIT
A0.6

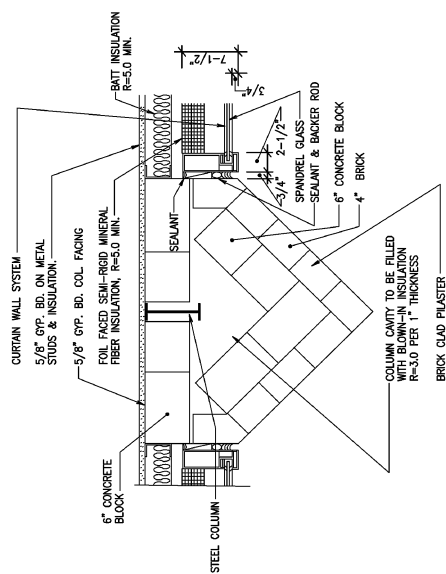

1 CURTAIN PLAN DETAIL AT SPANDREL GLASS
A0.6

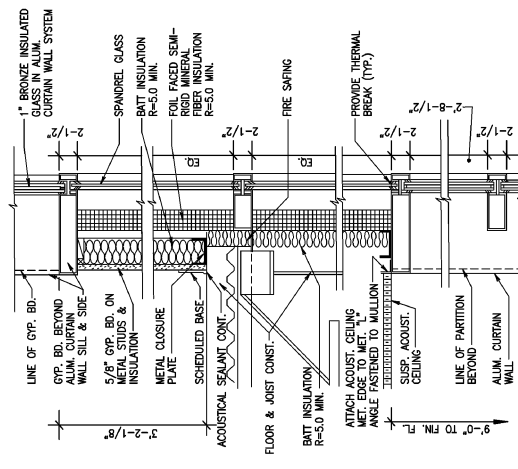

4 SECTION AT SPANDREL
A0.6

Fig. 22 Example Building Details
(not to scale)

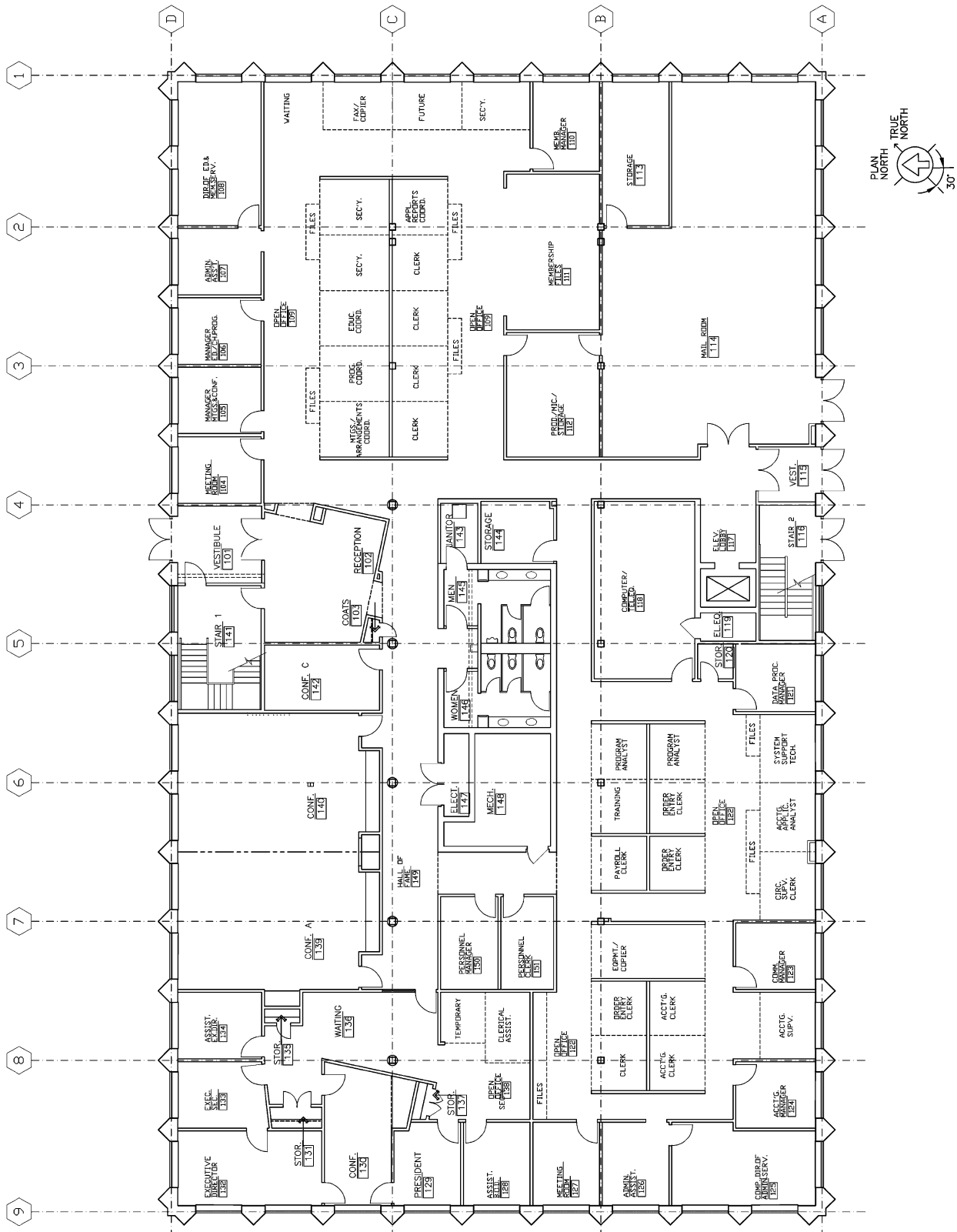

Fig. 23 First Floor Tenant Plan (not to scale)

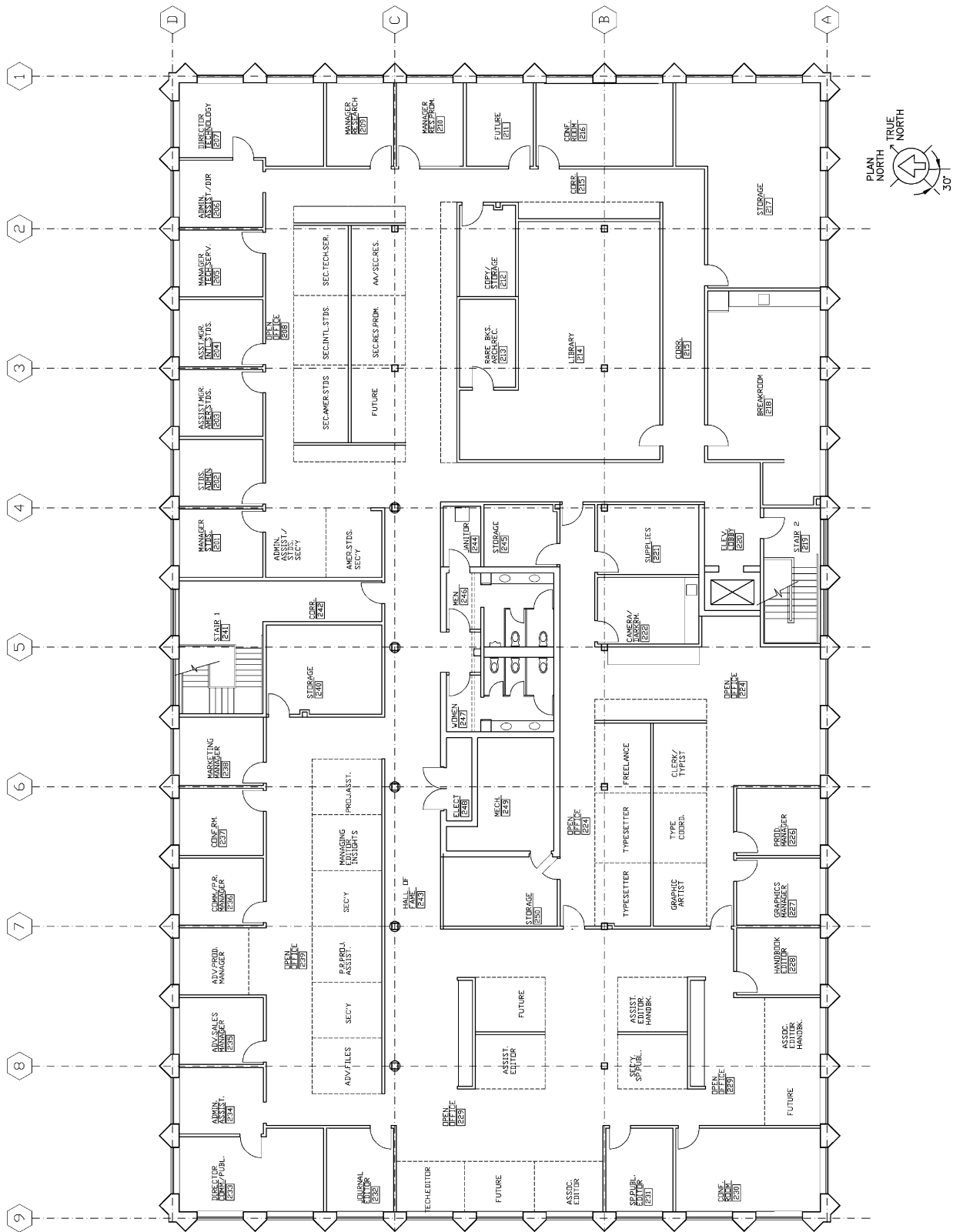

Fig. 24 Second Floor Tenant Plan (not to scale)

Licensed for single user. © 2009 ASHRAE, Inc.