



Standard Test Method for Determination of the In-Situ Stress in Rock Using the Hydraulic Fracturing Method¹

This standard is issued under the fixed designation D 4645; the number immediately following the designation indicates the year of original adoption or, in the case of revision, the year of last revision. A number in parentheses indicates the year of last reapproval. A superscript epsilon (ϵ) indicates an editorial change since the last revision or reapproval.

1. Scope*

1.1 This test method covers the determination of the in-situ state of stress in rock by hydraulic fracturing.

NOTE 1—Hydraulic fracturing for stress determination is also referred to as hydrofracturing, and sometimes as minifrac. Hydraulic fracturing and hydrofracturing may also refer to fracturing of the rock by fluid pressure for the purpose of altering rock properties, such as permeability and porosity.

1.2 Hydraulic fracturing is the widely accepted field method available for in situ stress measurements at depths greater than 50 m. It can be used in drill holes of any diameter.

1.3 Hydraulic fracturing can also be used in short holes for which other stress measuring methods, such as overcoring, are also available. The advantage of hydraulic fracturing is that it yields stresses averaged over a few square metres (the size of the induced hydraulic fracture) rather than over grain size areas, as in the case of overcoring techniques.

1.4 All observed and calculated values shall conform to the guidelines for significant digits and rounding established in Practice D 6026.

1.4.1 The method used to specify how data are collected, calculated, or recorded in this standard is not directly related to the accuracy to which the data can be applied in design or other uses, or both. How one applies the results obtained using this standard is beyond its scope.

1.5 The values stated in SI units are to be regarded as the standard.

1.6 *This standard does not purport to address all of the safety problems, if any, associated with its use. It is the responsibility of the user of this standard to establish appropriate safety and health practices and determine the applicability of regulatory limitations prior to use.*

2. Referenced Documents

2.1 *ASTM Standards:*²

¹ This test method is under the jurisdiction of ASTM Committee D18 on Soil and Rock and is the direct responsibility of Subcommittee D18.12 on Rock Mechanics.

Current edition approved Jan. 1, 2004. Published February 2004. Originally approved in 1987. Last previous edition approved in 1997 as D 4645 – 87 (1997).

² For referenced ASTM standards, visit the ASTM website, www.astm.org, or contact ASTM Customer Service at service@astm.org. For *Annual Book of ASTM Standards* volume information, refer to the standard's Document Summary page on the ASTM website.

D 653 Terminology Relating to Soil, Rock and Contained Fluids

D 2113 Practice for Diamond Core Drilling for Site Investigation

D 3740 Practice for Minimum Requirements for Agencies Engaged in the Testing and/or Inspection of Soil and Rock as Used in Engineering Design and Construction

D 5079 Practices for Preserving and Transporting Rock Core Sample

D 6026 Practice for Using Significant Digits in Geotechnical Data

3. Terminology

3.1 For terminology used in this test method, refer to Terminology D 653.

3.2 *Definitions of Terms Specific to This Standard:*

3.2.1 *breakdown pressure*—the pressure required to induce a hydraulic fracture in a previously intact test interval.

3.2.2 *in-situ stress*—rock stress measured in situ (as opposed to by remote sensing).

3.2.3 *secondary breakdown (or fracture reopening, or re-frac) pressure*—the pressure required to reopen a closed, previously induced hydrofracture after the test interval pressure has been allowed to return to its initial condition.

3.2.4 *shut-in pressure (or ISIP (instantaneous shut-in pressure))*—the pressure reached when the induced hydrofracture closes back after pumping is stopped.

3.2.5 *vertical and horizontal principal stresses*—the three principal stresses in situ are generally assumed to act one in the vertical direction and the other two in the horizontal plane.

4. Summary of Test Method

4.1 A section of the borehole is isolated by pressurizing two inflatable rubber packers. The fluid pressure in the sealed-off interval between the two packers is raised by pumping fluid into it at a controlled rate until a fracture occurs in the borehole wall. Pumping is stopped and the pressure in the interval is allowed to stabilize. The pressure is then reduced to the pore pressure level of the rock formation, and the pressurization process is repeated several times maintaining the same flow rate. Additional pressure cycles can be conducted at different flow rates. The magnitudes of the principal stresses are calculated from the various pressure readings. The orientation

*A Summary of Changes section appears at the end of this standard.

of the fracture is detected in order to determine the orientation of the transverse principal stresses. A typical pressure versus time, flow rate versus time record for a test interval is shown in Fig. 1.

5. Significance and Use

5.1 Limitations:

5.1.1 The depth of measurement is limited only by the length of the test hole.

5.1.2 Presently, the results of the hydraulic fracturing method can be interpreted in terms of in-situ stresses only if the boreholes are approximately parallel to one of the three principal in-situ stresses. Unless evidence to the contrary exists, vertical boreholes are assumed to be parallel to one of the in-situ principal stresses.

5.1.3 When the principal stress parallel to the borehole axis is not the least principal stress, only the two other principal stresses can be determined directly from the test. If the minimum stress acts along the borehole axis, fractures both parallel and perpendicular to the axis of the borehole are sometimes induced by the test, allowing for the determination of all three principal stresses.

5.1.4 In the unlikely event that the induced fracture changes orientation away from the borehole, its trace on the borehole wall cannot be used in stress determinations.

5.2 Assumptions:

5.2.1 The rock tested is assumed to be linearly elastic, homogeneous, and isotropic. Any excessive departure from these assumptions could affect the results.

5.2.2 Vertical boreholes are assumed to be substantially parallel to one of the in-situ principal stresses, since it has been established from many geological observations and stress measurements by other methods that in most cases one of the principal stresses is vertical to subvertical.

5.3 Hydraulic fracturing determination of in-situ stresses can be complicated by rock matrix porosity, naturally occurring fractures, the presence of nearby underground openings, and local variations in the stress field.

NOTE 2—The quality of the result produced by this standard is dependent on the competence of the personnel performing it, and the suitability of the equipment and facilities used. Agencies that meet the

criteria of Practice D 3740 are generally considered capable of competent and objective testing/sampling/inspection, etc. Users of this standard are cautioned that compliance with Practice D 3740 does not in itself assure reliable results. Reliable results depend on many factors; Practice D 3740 provides a means of evaluating some of those factors.

6. Apparatus

6.1 *Tripod or Drilling Rig*—Equipment for lowering the hydraulic fracturing tool into and lifting it from the test hole is necessary. To facilitate the lowering and lifting of the down-hole hydrofracturing tool, a tripod or a drilling rig is set up on top of the test hole. When high-pressure tubing or drilling pipes (rods) are used for lowering the tool, it is necessary to use a drilling rig with a derrick and hoist capable of lifting the combined weight of the pipe and instruments. When a wireline-flexible hose system is used for hydrofracturing, a well-designed tripod capable of carrying the weight of the testing tool, wireline, and hoses is employed.

6.2 *Straddle Packer*—Borehole sealing is accomplished by two inflatable rubber packers, spaced apart a distance equal to at least six hole diameters, and interconnected mechanically and hydraulically to form one unit called the straddle packer.

6.3 *High-Pressure Tubing or Hose*—Packer and test-interval pressurization is accomplished either by a high-pressure tubing (drilling rod is often a good substitute) or by high-pressure hose, or by a combination of the two (where tubing is used to pressurize the interval, and the hose, which is strapped to the outside of the tubing facilitates packer inflation). The hose or the tubing, or both, are connected hydraulically at one end to pumps or pressure generators (0.70 MPa, 0 to 25 L/min are recommended ratings), and at the other to the straddle packer and the test interval between the packers (Fig. 2). It has been found that pump capacities similar to those given here can overcome almost any common rock permeability and facilitate pressurization.

6.4 *Pressure Transducers and Flow Meter*—Pressure transducers (10 to 70 MPa) are used to monitor the test interval pressure either on the surface or at the test depth (or both). In some setups, the packer pressure is also monitored in the same way as the test interval. A flow meter is used to monitor the flow rate of fluid into the test interval. The sensing devices feed into multichannel analog time-base recorders for real-time

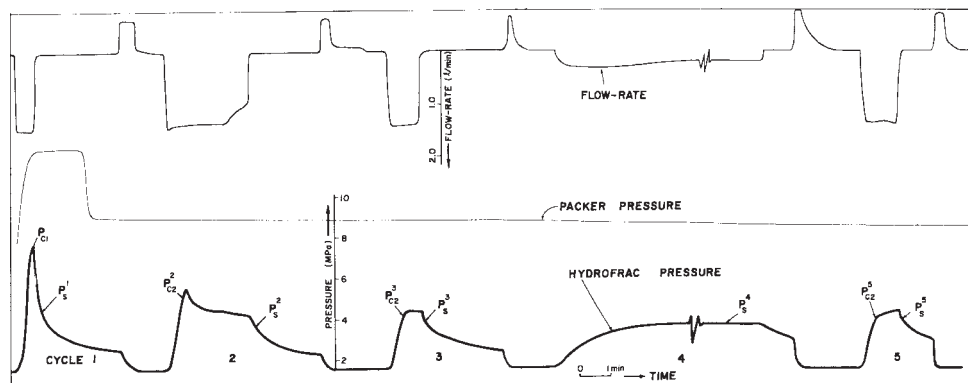

NOTE 1—In this test the flow rate was maintained constant during the first three cycles. In the fourth cycle a very slow flow rate was maintained such that the top level of the pressure-time curve could be considered as the upper limit for the shut-in pressure.

FIG. 1 Typical Pressure - Time, Flow Rate - Time Records During Hydrofracturing

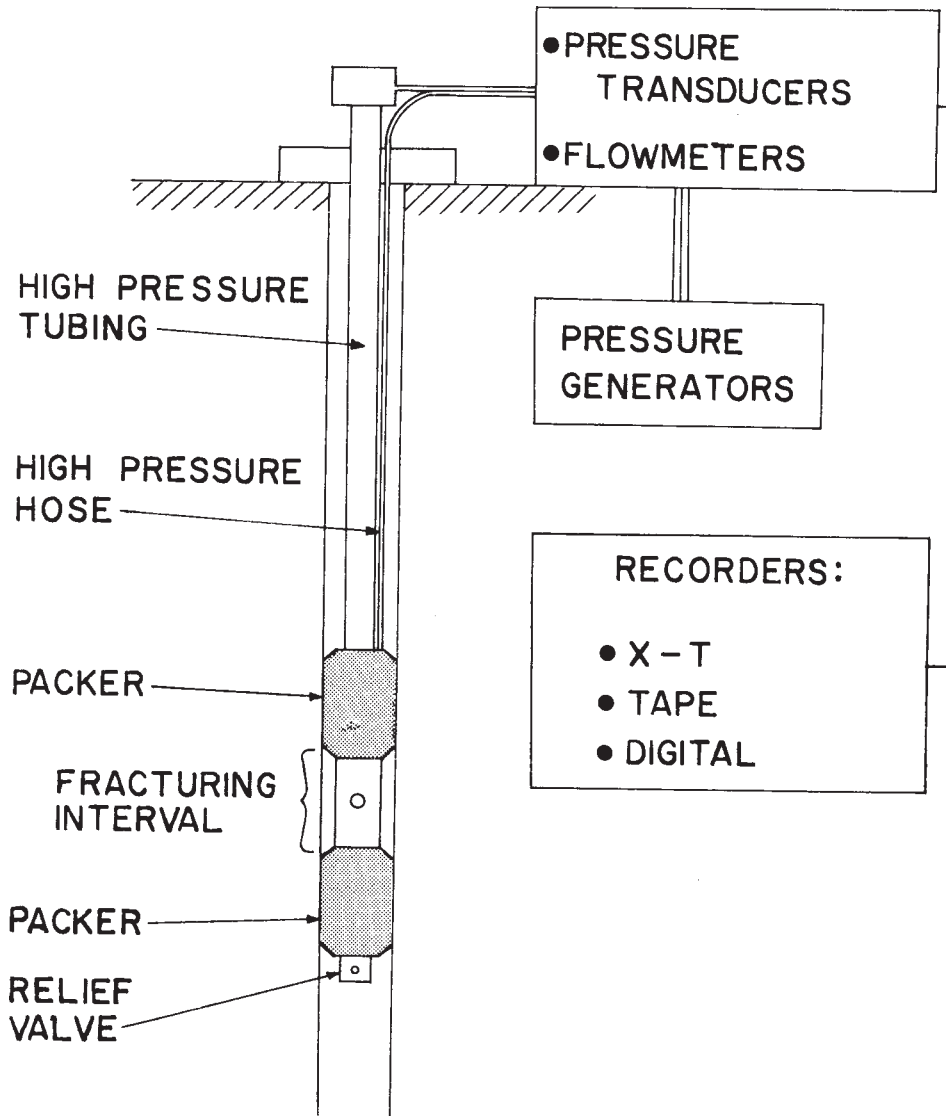

FIG. 2 Suggested Schematic Downhole and Surface Equipment Set Up for Hydraulic Fracturing

continuous permanent recording. Digital computer recording is carried out for the storage of test pressure and flow rate information which can later be used to provide a thorough analysis of the test data.

6.5 Hydrofracture Delineation Equipment:

6.5.1 *Impression Packer*—The presence and orientation of the induced hydrofracture is commonly recorded by the use of an impression packer, which is an inflatable packer with an outer layer of very soft semicured rubber. An orienting device, in the form of a magnetic borehole surveying tool or a gyroscopic borehole surveying tool, is used to determine the direction and inclination of the hydrofracture traced on the impression packer (Fig. 3).

6.5.2 *Borehole Televiwer*—An alternative to the oriented impression packer is the borehole televiwer, which is a sonic logging tool that takes an oriented acoustic picture of the borehole wall. This tool is considerably faster than the impression packer because it can take readings from an entire test hole in one trip. The impression packer requires retrieval after each test so that the outer cover can be properly marked or replaced

before lowering the tool to the next zone. However, the borehole televiwer is considerably more expensive to own or rent, does not always discern hydrofractures that have closed tightly after the pressurization stage of the test, and requires a fluid filled borehole.

7. Personnel Prequalification and Equipment Verification

7.1 *Test Personnel*—The performance of a hydraulic fracturing test may vary from location to location, and from one rock type to the next. Quick decisions, which are often required in the field, may change the outcome of the tests. Hence, the test supervisor should be a person who thoroughly understands the theoretical aspects of the test method, and who has had substantial experience in conducting such tests in a variety of rock types, depths, and locations.

7.2 *Drilling Personnel*—Quality drilling is important to maintaining a reasonably straight vertical hole and in keeping a nearly circular cross-section.

7.3 *Equipment Verification*—The compliance of all equipment and apparatus with performance specifications shall be

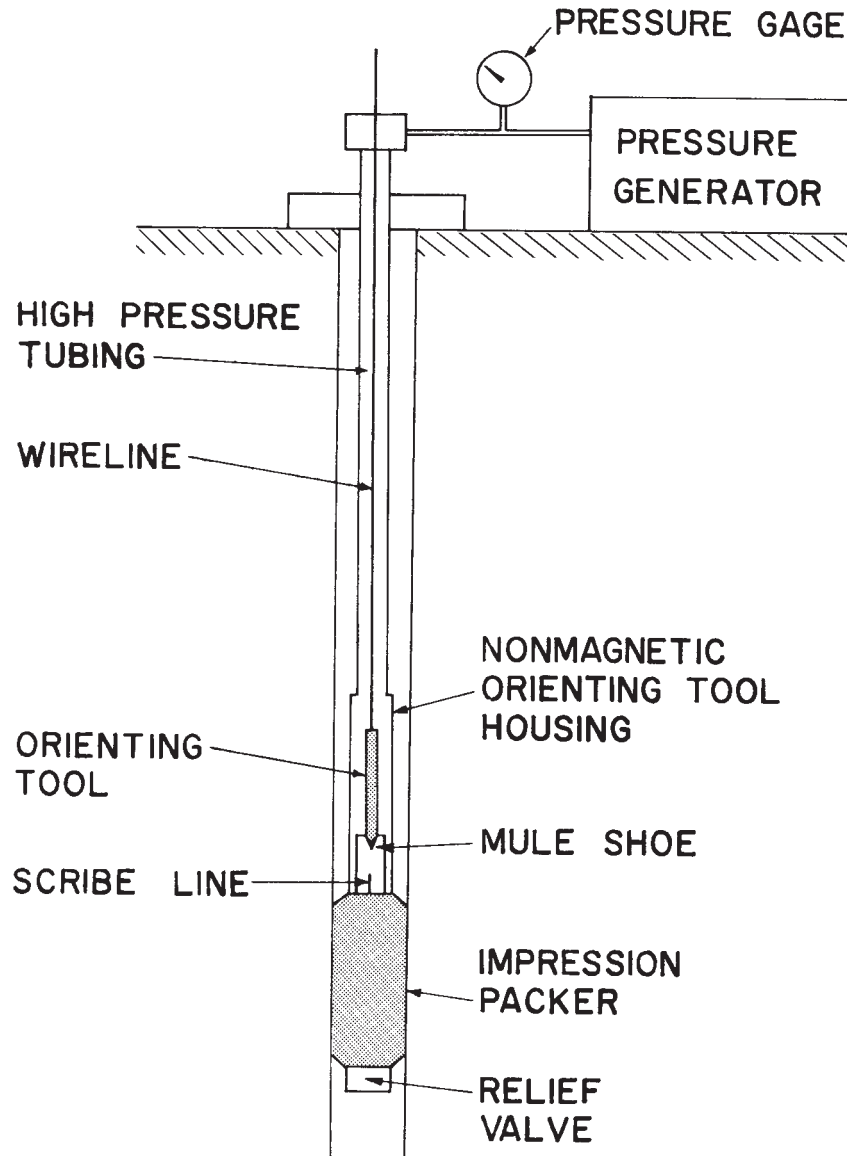

FIG. 3 Suggested Schematic Downhole and Surface Equipment Set Up for Taking a Packer Impression of the Hydraulic Fracture

verified. Performance specification is generally done by calibrating the equipment and measurement systems.

8. Procedure

8.1 Drill a borehole (in most cases in the vertical direction) to the depth of interest. Diamond bit coring is recommended because it yields a continuous core and leaves a smooth and uniformly circular borehole wall.

8.2 Select testing zones of solid unfractured rock within the drilled hole, making use of the core, if available, or one or more geophysical logs (such as caliper, density, borehole televiwer) if they have been run.

8.3 To seal off the test interval, lower the straddle packer to the predetermined depth of testing and pressurize hydraulically so as to inflate packers onto the wall of the borehole. The pressurization, typically using water, is generated on the

surface by a high-pressure pump and is conveyed to the packer by means of tubing or flexible hose.

8.4 With the packers well anchored to the sidewalls (a packer pressure of 3 MPa is usually sufficient at this stage of the test), pressurize hydraulically (typically using water) the test interval between the packers at a constant flow rate. This rate may change from one test hole to the next, often depending on the permeability of the rock (the higher the permeability the higher the rate). The general principle is to affect hydrofracturing within a minute or so from the beginning of interval pressure rise. Throughout the interval pressurization, maintain packer pressure at a level of about 2 MPa higher than the interval to ensure that no leak-offs occur. As the rock hydrofractures, the breakdown pressure is reached. If pumping is then stopped without venting the hydraulic line, the pressure will suddenly drop and settle at a lower level called the shut-in

pressure. Repeated cycling of the pressurization procedure using the same flow rate will yield the secondary breakdown pressure (the pressure required to reopen a preexisting hydrofracture), and additional values of the shut-in pressure.

8.5 Continuously record the entire pressurization process both as pressure versus time and as flow rate versus time.

8.6 At the conclusion of the test, vent the packer pressure to allow the packers to return to their original diameter. The entire straddle packer assembly can then either be moved to the next test zone or pulled out of the borehole.

8.7 The most common tool for determining hydraulic fracturing orientation is the oriented impression packer. Lower the packer on the drill-rod or wireline to the test interval after hydrofracturing, and inflate to a pressure higher than the secondary breakdown pressure or the shut-in pressure (whichever is larger). This ensures that the packer will slightly open the hydrofracture and enable the soft rubber covering to take a good imprint of the fracture. A magnetic compass (or a gyroscopic) borehole surveying tool is used to photograph the built-in compass face showing the azimuth of a fixed point on the packer. After some 30 min of pressurization, deflate the impression packer and retrieve. Trace the fracture impression and determine its orientation with respect to the fixed point on the packer so that it can also be oriented with respect to north.

NOTE 3—As mentioned in 6.5.2, acoustical borehole equipment, as well as other geophysical borehole equipment, can be used to map the hydraulic fracture too. Those techniques may be faster and less expensive, and some techniques may be able to give three dimensional data that can be very useful. These techniques usually require a pre-testing and post testing survey. However, as mentioned, they do not always discern hydraulic fractures that have closed tightly after the pressurization stage of the test and some of the methods require a fluid filled borehole.

9. Calculation

9.1 *General*—The calculation of in-situ principal stresses given here is for the commonly used vertical test holes. The pressure–time record, such as the one shown in Fig. 1, is used to obtain the test results required for the calculation; knowledge of the attitude of the hydrofracture at the borehole wall is necessary for the proper equations to be employed and for the correct interpretation of the calculation.

9.2 *Vertical Fracture*—If the vertical stress is not the least principal stress, the test results in a vertical fracture. In this case, the vertical stress can only be estimated from the weight of the rock overlying the test horizon, as follows:

$$\delta_v = \sum_{i=1}^n \gamma_i D_i \quad (1)$$

where:

σ_v = vertical stress,

γ_i = mean unit weight of rock layer i overlying test horizon,

D_i = thickness of rock layer i , and

n = total number of rock layers overlying the test horizon.

9.2.1 *Horizontal Stresses*—The two horizontal principal stresses can be calculated as follows:

$$\sigma_h = P_s \quad (2)$$

$$\sigma_H = T + 3\sigma_h - P_{c1} - P_o \quad (3)$$

where:

σ_h = minimum horizontal in-situ stress,

σ_H = maximum horizontal in-situ stress,

P_s = shut-in pressure at test horizon,

P_{c1} = breakdown pressure at test horizon,

P_o = pore fluid pressure at test horizon, and

T = tensile strength of hydrofractured rock.

NOTE 4—If pressures are recorded on the surface, the respective “test horizon” values are obtained by adding the head pressure (equivalent to the column of fluid between the surface and the test horizon) to the recorded surface values. Frictional losses are minimal when using water (the commonly used fracturing fluid) and are typically neglected.

9.2.2 The breakdown pressure (P_{c1}) is reached when the hydraulic fracturing is induced, and is represented by the peak of the pressure–time curve in the first pressurization cycle. Following breakdown the fracture opens up, accepts fluid, and the pressure drops suddenly. When pumping is ceased the shut-in pressure (P_s) is obtained presenting the pressure reached when the fracture closes again. In the first cycle the fracture may not have extended far enough from the test hole (at least 5 diameters) and the shut-in value tends to be high. In the following cycles pumping is continued for a short period of time (of the order of 1 min) after the fracture has reopened. The fracture is considered sufficiently long now and the shut-in pressures are more representative of the least horizontal stress. Unless the fracture intersects existing open joints or bypasses the packer elements, the shut-in pressure will remain approximately constant from cycle to cycle. Some methods of pinpointing the shut-in pressure on the pressure–time curves are described by Lee and Haimson³

9.2.3 The tensile strength (T) is not a constant parameter and varies with loading rate, specimen size, grain size, and mode of testing. The tensile strength can be determined in the laboratory, and used with stipulations regarding uncertainties. There is no direct way of determining T in the test hole. However, when it can be assumed with certainty that the hydrofractured rock closes back completely at the conclusion of a pressure cycle, the pressure required to reopen the fracture in the second pressurization cycle (fracture reopening pressure, or refrac pressure, P_{c2}) can be used instead of P_{c1} in Eq 3, as follows:

$$\sigma_H = 3\sigma_h - P_{c2} - P_o \quad (4)$$

9.2.3.1 The two equations are identical except that in Eq 4 it is assumed that $P_{c2} = P_{c1} - T$ since the tensile strength of the rock after fracturing (which has occurred in the first cycle) is zero. If the fracture closed completely, the slope of the pressure–time curve will be identical to that in the first cycle until the fracture opens and the slope changes. The point of slope change is taken as P_{c2} . If the fracture does not close completely, the pressure–time slope is never the same as in the first cycle and this technique of indirectly determining T cannot be used. It is recommended that P_{c2} be determined only from the second cycle during which the hydrofracture is fresh and little erosion and grain loosening has occurred. A method of

³ Lee, M. Y., and Haimson, B. C., “Statistical Evaluation of Hydraulic Fracturing Stress Measurement Parameters,” *Int. J. Rock Mech and Mining Sci.*, Vol 26, 1989, pp. 447-456.

pinpointing objectively P_{c2} on the pressure time curve is described by Lee and Hamison.³

9.2.4 The directions of the horizontal stresses are obtained from the following equalities:

$$\sigma_H \text{ direction} = \text{vertical fracture strike}$$

$$\sigma_h \text{ direction} = \text{direction of normal to vertical fracture strike}$$

9.2.4.1 This is based on the assumption (verified experimentally) that the fracture initiates and extends along the path of least resistance, that is, perpendicular to the least principal stress.

9.3 *Vertical and Horizontal Fractures*—When σ_v is the overall least principal stress, the orientation of the hydrofracture away from the test hole should be horizontal. At the borehole wall, however, the stress distribution in intact massive rock favors a vertical fracture in the direction of σ_H . Thus, the initial hydrofracture will be vertical and in the first cycle(s) the pressure–time curve will behave the same as described in 9.2. In subsequent cycles, however, as the fracture extends it will often reorient to be perpendicular to the least principal stress, that is, it will turn into a horizontal fracture. The respective shut-in pressure will decline to a value approximately equal to the vertical stress. The packer impression or the sonic televiewer log will confirm the existence of both vertical and horizontal fractures. This hydrofracture configuration allows the direct calculation of all three principal stresses:

$$\sigma_h = P_{s1} \quad (5)$$

$$\sigma_H = T + 3\sigma_h - P_{c1} - P_o$$

or:

$$\sigma_H = 3\sigma_h - P_{c2} - P_o \quad (6)$$

$$\sigma_v = P_{s2}$$

where:

P_{s1} = first shut-in pressure, and

P_{s2} = second shut-in pressure.

9.3.1 If the amount of fluid pumped into the fracture is calculated to be sufficient to extend the fracture by no more than 3 to 4 diameters during each pressurization cycle, then the vertical fracture and its respective shut-in will typically persist for the first 2 to 3 cycles. Thereafter there will be a continuing decrease in shut-in pressure value (sometimes for 2 to 3 cycles) until the second shut-in plateau is reached coinciding with the development of the horizontal fracture. This shut-in value will persist in further pressurization cycles.

9.4 *Horizontal Fracture*—When σ_v is the overall least principal stress and the test hole wall is not free of bedding plans, partings or other horizontal discontinuities, even minor ones, one or more horizontal fractures may develop. In this case the only stress that the hydrofracturing test helps calculate is σ_v :

$$\sigma_v = P_s \quad (7)$$

9.4.1 The only quantitative evaluation of the horizontal stresses is then given by:

$$\sigma_H \geq \sigma_h \geq \sigma_v (= P_s) \quad (8)$$

9.5 *Inclined Fractures*—It is sometimes possible to induce inclined hydrofractures. This can result from significant misalignment of the principal stress directions with the test hole

axis and the plane normal to the axis. In this rather unusual case, the calculations described in 9.2 and 9.3 can still be used to approximate the principal stresses if the plane of the hydrofracture deviates less than 15° from the vertical. A more precise method of obtaining the in-situ stresses in this situation has been suggested by Cornet and Valette.⁴

10. Report

10.1 This section establishes the minimum requirements for a complete and usable report. Further details may be added as appropriate, and the order of the items may be changed if necessary.

10.2 Introduction:

10.2.1 The purpose of the tests; examples are for tunnel or cavern design, design of pressure tunnel lining, characterization of tectonic setting.

10.2.2 Details of site location, including a map (preferably topographic) and latitude and longitude.

10.2.3 Reasons for selecting the site location vis-a-vis the purpose of the tests.

10.2.4 Details of the test hole, such as hole inclination, diameter, depth, drilling method, core availability, water table in hole, and unusual fluid pressures in the hole if known to exist.

10.2.5 Test site geology, including a summary of regional and local geology, the type of rock or rocks encountered in the test hole, detailed geology in the test interval and immediately above and below the test interval, and a description of the general geological structure such as faults, joint sets, folding, and tectonic setting.

10.3 Test Method:

10.3.1 Describe in detail equipment and equipment set-up including a diagram, and list by name, model number, basic specifications of each major piece, and the most recent calibration.

10.3.2 Describe in detail the procedure actually used for the test and include flow rates, number of pressurization cycles, and fluid volume used per cycle. Also include here the number of tests and the basis for selection of specific test depths.

10.3.3 If the actual equipment or procedure varies from the requirements contained in this test method, note each variation, the reason for it, and discuss the effect on the test results.

10.4 Theoretical Background:

10.4.1 Clearly present and define all equations used to reduce the data. Note any assumptions inherent in the equations or limitations in their applications and discuss the effect on the results.

10.4.2 Discuss the degree to which the actual test site conditions conform to the assumptions contained in the data reduction equations. Fully explain any factors or methods applied to the data to correct for a discrepancy in conditions.

10.5 Results:

10.5.1 Use the pressure – time, flow – time records, to construct a table containing test number, depth, pore pressure,

⁴ Cornet, F. H., and Valette, B., "In Situ Stress Determination from Hydraulic Injection Test Data," *Journal of Geophysical Research*, Vol 89, 1984, pp. 11527–11537.

cycle number and the respective breakdown pressure, fracture reopening pressure, shut-in pressure, and flow rate. Place a copy of the original record in the appendix. Clearly explain and justify the method(s) used to determine the different pressures necessary for stress calculation.

10.5.2 Use the fracture delineation record to construct a table giving the test number, depth, and hydrofracture inclination and direction (or fracture strike and dip in geological terms). Include in the appendix accurate replicas of the impression packer fracture trace or photographs of the sonic televiewer log (depending on the method used).

10.5.3 Record vertical and horizontal principal stresses by a sample calculation and a summary table including the test number, test depth, pore pressure, selected breakdown pressure or fracture reopening pressure, or both, shut-in pressure(s), and the tensile strength (where applicable), together with the calculated vertical stress, least horizontal stress, largest horizontal stress, and the direction of the largest horizontal stress for each test.

10.5.4 A graphic presentation of the magnitudes and directions of the principal stresses (for example: as a function of depth, and in stereographic projection) is recommended.

10.5.5 Other types of data analysis and presentations may be included as appropriate, such as the state of stress in each of the rock formations tested (if more than one), the variation of stress with depth, the relationship of the measured state of stress to the local or regional geological structure, or both, including the type of faults, the relationship of the measured stress to local or regional fault plane solutions of earthquakes, or both, and others.

10.6 Error Estimate:

10.6.1 Evaluate the error associated with the uncertainty of the electronic devices and the correct determination of the different pressures such as P_{c1} , P_{c2} , and P_s .

10.6.2 Compute the effect the measurement errors have on the calculated stress and state in absolute pressure values or in percentage, or both, of the presented stress magnitudes.

10.7 Two appendixes are recommended: one containing all the field data collected during hydrofracturing, that is, the pressure – time, flow-rate – time records, and the other containing information on hydrofracture delineation on the testhole wall, including fracture orientation with respect to north.

11. Precision and Bias

11.1 Due to the nature of the rock materials tested by this test method it is either not feasible or too costly at this time to produce multiple specimens which have uniform physical properties. Any variation observed on the data is just as likely to be due to specimen variation as to operator or laboratory testing variation. Subcommittee D18.12 welcomes proposals that would allow for development of a valid precision statement. There is no accepted reference value of rock for this test method; therefore, bias cannot be determined.

12. Keywords

12.1 drill holes; fluid pressure; hydraulic fracturing; in situ stress

SUMMARY OF CHANGES

- (1) Added Summary of changes and noted in Section 1 titled.
- (2) Added caveat for significant figures in Section 1
- (3) Added reference section as Section 2 and renumbered following sections.
- (4) Added references D 653, D 2113, D 3740, D 5079, and D 6026 to reference section.
- (5) Deleted the word “critical” as a synonym for “breakdown” in the terminology section and in all other sections.
- (6) Added the word “closed” after “reopened” in the section 2.1.3.
- (7) Added the word “generally” before the word “assumed” in section 2.1.5.
- (8) Added caveat for D 3740 on competence in the significance and use section.
- (9) Changed “expression in” to “trace on” in section 4.1.4.
- (10) Changed symbol for vertical stress in equation 1 to agree with list of symbols below equation.

- (11) In the list of symbols for Eq 1 “mean density” was changed to “unit weight.”
- (12) The last sentence in section 8.5 titled “Inclined Fractures” was deleted.
- (13) Added note in section 8.7 about the use of downhole geophysical methods for determining fracture orientation.
- (14) Reference 3 was changed to Lee, M. Y., and Haimson, B. C., “Statistical Evaluation of Hydraulic Fracturing Stress Measurement Parameters,” *Int. 2 Rock Mech and Mining Sci.*, Vol 26, 1989, pp. 447-456.
- (15) The following sentence was added to section 8.2.3: “The tensile strength can be determined in the laboratory, and used with stipulations regarding uncertainties.”
- (16) The following sentence was added to section 8.2.3.1: “A method of pinpointing objectively P_{c2} on the pressure time curve is described by Lee and Hamison.”
- (17) Removed “Tape” from list of recorders in Fig. 2.

ASTM International takes no position respecting the validity of any patent rights asserted in connection with any item mentioned in this standard. Users of this standard are expressly advised that determination of the validity of any such patent rights, and the risk of infringement of such rights, are entirely their own responsibility.

This standard is subject to revision at any time by the responsible technical committee and must be reviewed every five years and if not revised, either reapproved or withdrawn. Your comments are invited either for revision of this standard or for additional standards and should be addressed to ASTM International Headquarters. Your comments will receive careful consideration at a meeting of the responsible technical committee, which you may attend. If you feel that your comments have not received a fair hearing you should make your views known to the ASTM Committee on Standards, at the address shown below.

This standard is copyrighted by ASTM International, 100 Barr Harbor Drive, PO Box C700, West Conshohocken, PA 19428-2959, United States. Individual reprints (single or multiple copies) of this standard may be obtained by contacting ASTM at the above address or at 610-832-9585 (phone), 610-832-9555 (fax), or service@astm.org (e-mail); or through the ASTM website (www.astm.org).